



DEPARTMENT OF REGULATORY AND ECONOMIC RESOURCES (RER)  
BOARD AND CODE ADMINISTRATION DIVISION

**NOTICE OF ACCEPTANCE (NOA)**

MIAMI-DADE COUNTY  
PRODUCT CONTROL SECTION  
11805 SW 26 Street, Room 208  
Miami, Florida 33175-2474  
T (786) 315-2590 F (786) 315-2599  
[www.miamidade.gov/economy](http://www.miamidade.gov/economy)

**PGT Industries, LLC**  
**3400 Precision Drive**  
**North Venice, FL 34275**

**SCOPE:**

This NOA is being issued under the applicable rules and regulations governing the use of construction materials. The documentation submitted has been reviewed and accepted by Miami-Dade County RER -Product Control Section to be used in Miami Dade County and other areas where allowed by the Authority Having Jurisdiction (AHJ).

This NOA shall not be valid after the expiration date stated below. The Miami-Dade County Product Control Section (In Miami Dade County) and/or the AHJ (in areas other than Miami Dade County) reserve the right to have this product or material tested for quality assurance purposes. If this product or material fails to perform in the accepted manner, the manufacturer will incur the expense of such testing and the AHJ may immediately revoke, modify, or suspend the use of such product or material within their jurisdiction. RER reserves the right to revoke this acceptance, if it is determined by Miami-Dade County Product Control Section that this product or material fails to meet the requirements of the applicable building code.

This product is approved as described herein and has been designed to comply with the Florida Building Code, including the High Velocity Hurricane Zone.

**DESCRIPTION: Series "5470" Vinyl Sliding Glass Door (Reinforced)-N.I.**

**APPROVAL DOCUMENT:** Drawing No. **SGD-5470 Rev E**, titled "Vinyl Sliding Glass Door NOA (NI)", sheets 1 through 21 of 21, prepared by manufacturer, dated 10/05/15 and revised on 01/21/26, signed and sealed by Anthony L. Miller, P.E., bearing the Miami-Dade County Product Control Revision stamp with the Notice of Acceptance number and expiration date by the Miami-Dade County Product Control Section.

**MISSILE IMPACT RATING: None: Applicable Hurricane Protection devices, complying w/ FBC, required.**

**Limitations:**

1. See table 1 (sheet 7) and table 2 (sheet 8) for applicable SGD unit sizes, design pressures, reinforcement types, glass types, sill riser (see tables B-1 & B-2, sheets 7-8) and anchor layout sheets requirements in 11 thru 16.
2. Rigid White PVC, Tan (Non-White) Rigid PVC and Black and lighter shade cap coated Rigid PVC and White Rigid PVC (Painted or laminated) to be labeled per referenced NOA's requirements.
3. Egress operable doors must comply with min clear width or height per FBC requirement, as applicable.
4. Pocket walls under separate approval, to be reviewed by Building officials.

**LABELING:** Each unit shall bear a permanent label with the manufacturer's name or logo, city, state and series and following statement: "Miami-Dade County Product Control Approved", noted herein.

**RENEWAL** of this NOA shall be considered after a renewal application has been filed and there has been no change in the applicable building code negatively affecting the performance of this product.

**TERMINATION** of this NOA will occur after the expiration date or if there has been a revision or change in the materials, use, and/or manufacture of the product or process. Misuse of this NOA as an endorsement of any product, for sales, advertising or any other purposes shall automatically terminate this NOA. Failure to comply with any section of this NOA shall be cause for termination and removal of NOA.

**ADVERTISEMENT:** The NOA number preceded by the words Miami-Dade County, Florida, and followed by the expiration date may be displayed in advertising literature. If any portion of the NOA is displayed, then it shall be done in its entirety.

**INSPECTION:** A copy of this entire NOA shall be provided to the user by the manufacturer or its distributors and shall be available for inspection at the job site at the request of the Building Official.

This NOA **revises & renews NOA #23-0710.09** and consists of page 1, and evidence pages E-1, E-2, E-3, E-4, E-5, E-6, E-7 and E-8, as well as approval document mentioned above.

The submitted documentation was reviewed by **Ishaq I. Chanda, P.E.**



*Ishaq I. Chanda*  
2/4/26

NOA No. 26-0126.02  
Expiration Date: April 21, 2031  
Approval Date: March 05, 2026  
Page 1

NOTICE OF ACCEPTANCE: EVIDENCE SUBMITTED

**1. Evidence submitted under previous NOA**

**A. DRAWINGS**

1. Manufacturer's die drawings and sections. *(Submitted under NOA No. 11-0107.09)*
2. Drawing No. **SGD-5470**, titled "Vinyl Sliding Glass Door NOA (NI)", sheets 1 through 21 of 21, prepared by manufacturer, dated 10/05/15, with Revision A dated 04/05/17, signed and sealed by Anthony L. Miller, P.E.

**B. TESTS**

1. Test report on
  - 1) Air Infiltration Test, per FBC, TAS 202-94
  - 2) Uniform Static Air Pressure Test, per FBC, TAS 202-94
  - 3) Water Resistance Test, per FBC, TAS 202-94.
  - 4) Forced Entry Test, per FBC, TAS 202-94along with marked-up drawings and installation diagram of vinyl sliding glass door, prepared by Fenestration Testing Lab, Inc., Test Report No. **FTL 6637** (samples A-1 thru A-5), dated 11/19/10, signed and sealed by Jorge A. Causo, P. E. *(Submitted under NOA No. 11-0107.09)*
2. Additional test report No. **FTL 6638** (samples A-1 thru A-22) per TAS 201/203-94, issued by Fenestration Testing Lab, Inc., dated 11/19/10, signed and sealed by Jorge A. Causo, P. E. *(Submitted under NOA No. 11-0107.04)*
3. Additional test report No. **FTL 8717**, issued by Fenestration Testing Lab, Inc., dated 12/07/15, revised on 02/15/16 and 02/24/16, signed and sealed by Idalmis Ortega, P. E. *(Submitted under NOA No. 15-1210.01)*
4. Additional test report No. **FTL 8546** issued by Fenestration Testing Lab, Inc., dated 11/06/15, revised on 01/04/16 and 02/11/16, signed and sealed by Idalmis Ortega, P. E. *(Submitted under NOA No. 15-1210.01)*
5. Additional test report No. **FTL 8547** issued by Fenestration Testing Lab, Inc., dated 12/04/15, revised on 02/15/16, signed and sealed by Idalmis Ortega, P. E. *(Submitted under NOA No. 15-1210.01)*
6. Additional test report No. **FTL 8548** issued by Fenestration Testing Lab, Inc., dated 12/04/15, revised on 01/04/16 and 02/11/16, signed and sealed by Idalmis Ortega, P. E. *(Submitted under NOA No. 15-1210.01)*
7. Additional test report No. **FTL 8549** issued by Fenestration Testing Lab, Inc., dated 12/04/15, revised on 12/04/15 and 02/11/16, signed and sealed by Idalmis Ortega, P. E. *(Submitted under NOA No. 15-1210.01)*
8. Additional test report No. **FTL 8552** issued by Fenestration Testing Lab, Inc., dated 12/04/15, revised on 02/15/16, signed and sealed by Idalmis Ortega, P. E. *(Submitted under NOA No. 15-1210.01)*

**C. CALCULATIONS**

1. Anchor verification calculations and structural analysis, complying with FBC-2014, prepared by PGT, dated 12/09/15 and last revised on 02/15/16, signed and sealed by Anthony L. Miller, P.E. *(Submitted under NOA No. 15-1210.02)*.
2. Glazing complies with ASTM E-1300-02, -04 & -09.

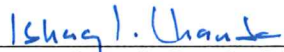
  
Ishaq I. Chanda, P.E.  
Product Control Unit Supervisor  
NOA No. 26-0126.02  
Expiration Date: April 21, 2031  
Approval Date: March 05, 2026

NOTICE OF ACCEPTANCE: EVIDENCE SUBMITTED

**D. QUALITY ASSURANCE**

1. Miami Dade Department of Regulatory and Economic Resources (RER).

**E. MATERIAL CERTIFICATIONS**

1. Notice of Acceptance No. **15-0528.14** issued to Vision Extrusion Limited for their “**White Rigid PVC Exterior Extrusions for Windows and Doors**”, dated 08/13/15, expiring on 09/30/19.
2. Notice of Acceptance No. **16-0920.08** issued to Vision Extrusion Limited for their “**VE 1000 Tan 202 and lighter Shades (Non-White) Rigid PVC Exterior Extrusions for Windows and Doors**”, dated 12/08/16, expiring on 12/29/21.
3. Notice of Acceptance No. **15-0528.15** issued to Vision Extrusion Limited for their “**Brown Coated (Painted or Laminated) White Rigid PVC Exterior Extrusions for Windows and Doors**”, dated 08/13/15, expiring on 09/30/19.
4. Notice of Acceptance No. **16-0712.02** issued to ENERGI Fenestration Solutions USA, Inc. for their “**TAN 3040 and Lighter Shades (Non-White) Rigid PVC Exterior Extrusions for Windows and Doors**” dated 09/15/16, expiring on 02/04/21.
5. Notice of Acceptance No. **16-0712.04** issued to ENERGI Fenestration Solutions USA, Inc. for their “**Bronze and Lighter Shades of Cap Coated Rigid PVC Exterior Extrusions for Windows and Doors**” dated 09/15/16, expiring on 04/16/20.
6. Notice of Acceptance No. **16-0712.03** issued to ENERGI Fenestration Solutions USA, Inc. for their “**White Rigid PVC Exterior Extrusions for Windows and Doors**” dated 08/10/17, expiring on 02/28/18.
7. Test reports No(s). 10-002-792(A), 10-06-M0527, 535753-09, per ASTM E-84, ASTM D1929 and ASTM D-635, issued by EXOVA to Vision Extrusion for cellulosic composite material. *(Submitted under NOA No. 11-0107.04)*

**F. STATEMENTS**

1. Statement letter of conformance with **FBC-5<sup>th</sup> Edition (2014)** and **FBC-6<sup>th</sup> Edition (2017)**, issued by manufacturer, dated 08/14/17, signed & sealed by Lynn Miller, P.E.
2. Statement letter of no financial interest, dated 04/18/17, issued by manufacturer, signed & sealed by Lynn Miller, P.E.
3. Letter of lab compliance, part of the above test reports.

**G. OTHER**

1. Notice of Acceptance No. **15-1210.02**, issued to PGT Industries, for their Series “**5470**” **Vinyl Sliding Glass Door (Reinforced) – N.I.**”, approved on 03/03/16 and expiring on 04/21/21.

  
\_\_\_\_\_  
Ishaq I. Chanda, P.E.  
Product Control Unit Supervisor  
NOA No. 26-0126.02  
Expiration Date: April 21, 2031  
Approval Date: March 05, 2026

NOTICE OF ACCEPTANCE: EVIDENCE SUBMITTED

2. Evidence Submitted under previous submittal

A. DRAWINGS

1. Drawing No. **SGD-5470 Rev B**, titled "Vinyl Sliding Glass Door NOA (NI)", sheets 1 through 21 of 21, prepared by manufacturer, dated 10/05/15 and revised on 04/22/20, signed and sealed by Anthony L. Miller, P.E.

B. TESTS

1. Test reports on:
  - 1) Air Infiltration Test, per FBC, TAS 202-94
  - 2) Uniform Static Air Pressure Test, Loading per FBC, TAS 202-94
  - 3) Water Resistance Test, per FBC, TAS 202-94
  - 4) Large Missile Impact Test per FBC, TAS 201-94
  - 5) Cyclic Wind Pressure Loading per FBC, TAS 203-94

along with marked-up drawings and installation diagram of all PGT Industries, Inc. representative units listed below and tested to qualify **Dowsil 791** and **Dowsil 983** silicones, prepared by Fenestration Testing Laboratory, Inc., Test Reports No.:

**FTL-7897**, PGT PW5520 PVC Fixed Window (unit 6 in proposal), dated 09/03/14  
**FTL-20-2107.1**, PGT SGD780 Aluminum Sliding Glass Door (unit 7 in proposal) **FTL-20-2107.2**, PGT CA740 Alum. Outswing Casement Window (unit 8 in proposal) **FTL-20-2107.3**, PGT PW7620A Aluminum Fixed Window (unit 9 in proposal) and **FTL-20-2107.4**, PGT PW7620A Aluminum Fixed Window (unit 10 in proposal) dated 07/13/20, all signed and sealed by Idalmis Ortega, P.E.

C. CALCULATIONS

1. Anchor verification calculations and structural analysis, complying with **FBC 7<sup>th</sup> Edition (2020)**, dated 04/22/20, prepared by manufacturer, signed and sealed by Anthony Lynn Miller, P.E.
2. Glazing complies with **ASTM E1300-04, -09, -12 and -16**.

D. QUALITY ASSURANCE

1. Miami-Dade Department of Regulatory and Economic Resources (RER).

E. MATERIAL CERTIFICATIONS

1. Notice of Acceptance No. **18-1106.10** issued to Vision Extrusions Limited for their "**Brown Coated (Painted or Laminated) White Rigid PVC Exterior Extrusions for Windows and Doors**", expiring on 09/30/24.
2. Notice of Acceptance No. **18-1106.11** issued to Vision Extrusions Limited for their series "**VE 1000 Tan 202 and lighter shades (Non-White) Rigid Cellular PVC Exterior Extrusions for Windows and Doors**", expiring on 12/29/21.
3. Quanex Part **Super Spacer Standard** complying with ASTM C518 Thermal Conductivity 0.881 BTU-in/ hr.-ft<sup>2</sup>-°F, ASTM F 1249 WVTR-Pass, ASTM D3985 Oxygen-Pass, ASTM E 2190 I.G. Durability-No Fog-Pass. (*Submitted under previous NOA No. 15-0409.05*).
4. Quanex Part **Duraseal** complying with ASTM C518 Thermal Conductivity 2.22 BTU-in/ hr.-ft<sup>2</sup>-°F, ASTM F 1249 WVTR-Pass, ASTM D 1434 Argon Permeance-Pass, ASTM E 2189 I.G. Durability-No Fog, ASTM E 546 Dew Point Development -20°F in 48 hrs. (*Submitted under NOA No. 15-0409.05*).

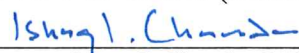
  
Ishaq I. Chanda, P.E.  
Product Control Unit Supervisor  
NOA No. 26-0126.02  
Expiration Date: April 21, 2031  
Approval Date: March 05, 2026

NOTICE OF ACCEPTANCE: EVIDENCE SUBMITTED

**E. MATERIAL CERTIFICATIONS (continue)**

5. Vision Extrusions, Ltd. Parts complying with PVC-AAMA 303-13, Voluntary Specification for Rigid Polyvinyl Chloride (PVC) Exterior Profiles for Vision Extrusions, Ltd.-VEX-1 by AAMA Fenestration Exterior Profile Certification Program. *(Submitted under NOA No. 15-0409.05).*
6. Vision Extrusions Ltd. Parts complying with PVC-AAMA 303-13. *(Submitted under NOA No. 15-0409.05).*
7. PVC-AAMA 303-13, Voluntary Specification for Rigid Polyvinyl Chloride (PVC) Exterior Profiles for Vision Extrusions, Ltd.-VEX-1 by AAMA Fenestration Exterior Profile Certification Program.
8. Notice of Acceptance No. **18-1217.14** issued to Energi Fenestration Solution, USA, Inc. for their “**Tan 3040 & light shade (non-white) White Rigid PVC Exterior Extrusions for Windows and Doors**”, expiring on 02/04/21.
9. Notice of Acceptance No. **18-0122.02** issued to Energi Fenestration Solution, USA, Inc, for their series “**White Rigid PVC Exterior Extrusions for Windows and Doors**”, expiring on 02/28/23.
10. Notice of Acceptance No. **20-0203.03** issued to Energi Fenestration Solution, USA, Inc. for their “**Bronze & light shade cap coated White Rigid PVC Exterior Extrusions for Windows and Doors**”, expiring on 04/16/25.

**F. STATEMENTS**

1. Statement letter of conformance to **FBC 7<sup>th</sup> Edition (2020)**, dated 04/22/20, issued by manufacturer, signed and sealed by Anthony Lynn Miller, P.E.
2. Statement letter of no financial interest and of independence, issued by manufacturer, dated 04/18/20, signed and sealed by Anthony Lynn Miller, P.E.

**G. OTHERS**

1. This NOA **revises NOA# 17-0420.07** and updates to **FBC2020 (7<sup>th</sup> Edition)**, expiring 04/21/21.
2. RER Test proposals **#19-1155** dated 01/10/20 approved by Ishaq I. Chanda, P.E.



---

Ishaq I. Chanda, P.E.  
Product Control Unit Supervisor  
NOA No. 26-0126.02  
Expiration Date: April 21, 2031  
Approval Date: March 05, 2026

**NOTICE OF ACCEPTANCE: EVIDENCE SUBMITTED**

**3. Evidence Submitted under previous approval**

**A. DRAWINGS**

1. Drawing No. **SGD-5470 Rev C**, titled "Vinyl Sliding Glass Door NOA (NI)", sheets 1 through 21 of 21, prepared by manufacturer, dated 10/05/15 and revised on 02/01/21, signed and sealed by Anthony L. Miller, P.E.

Note: This revision consists replacement of same existing installation screw with flat head.

**B. TESTS**

1. None.

**C. CALCULATIONS**

1. None.

**D. QUALITY ASSURANCE**

1. Miami-Dade Department of Regulatory and Economic Resources (RER).

**E. MATERIAL CERTIFICATIONS**

1. None.

**F. STATEMENTS**

1. Statement letter of conformance to **FBC 7<sup>th</sup> Edition (2020)**, dated 02/01/21, issued by manufacturer, signed and sealed by Anthony Lynn Miller, P.E.
2. Statement letter of no financial interest and of independence, issued by manufacturer, dated 02/01/21, signed and sealed by Anthony Lynn Miller, P.E.

**G. OTHERS**

1. This NOA revises & renews NOA# **20-0429.06**, expiring 04/21/26.



---

**Ishaq I. Chanda, P.E.**  
**Product Control Unit Supervisor**  
**NOA No. 26-0126.02**  
**Expiration Date: April 21, 2031**  
**Approval Date: March 05, 2026**

**NOTICE OF ACCEPTANCE: EVIDENCE SUBMITTED**

**4. EVIDENCE SUBMITTED under previous approval**

**A. DRAWINGS**

1. Drawing No. **MD-5470.0**, titled “Vinyl Sliding Glass Door (NI)”, sheets 1 through 21 of 21, dated 10/05/15, with revision **D** dated 06/06/23, prepared by manufacturer, signed and sealed by Anthony Lynn Miller, P.E.

**B. TESTS**

1. None.

**C. CALCULATIONS**

1. None

**D. QUALITY ASSURANCE**

1. Miami-Dade Department of Regulatory and Economic Resources (RER)

**E. MATERIAL CERTIFICATIONS**

1. Notice of Acceptance No. **21-1109.04**, issued to **Vision Extrusions Group Limited**, for their **White Rigid PVC Exterior Extrusions for Windows and Doors**, approved on 03/31/22, expiring on 09/30/24.
2. Notice of Acceptance No. **22-0214.04**, issued to **Vision Extrusions Group Limited**, for their **VE 1000 Tan 202 and Lighter Shades (Non-White) Rigid PVC Exterior Extrusions for Windows and Doors**, approved on 06/30/22, expiring on 04/16/25.
3. Notice of Acceptance No. **23-0821.09** issued to **Vision Extrusions Group Limited**. for their **“Tan 3040 & light shade (non-white) White Rigid PVC Exterior Extrusions for Windows and Doors”**, expiring on 02/04/26.
4. Notice of Acceptance No. **18-1108.10**, issued to **Vision Extrusions Group Limited**, for their **Brown Coated (Painted or Laminated) White Rigid PVC Exterior Extrusions for Windows and Doors**, expiring on 02/04/26.

**F. STATEMENTS**

1. Statement letter of conformance, complying with **FBC 7<sup>th</sup> Edition (2020)**, and with **FBC 8<sup>th</sup> Edition (2023)** dated June 06, 2023, issued by manufacturer, signed and sealed by Anthony Lynn Miller, P.E.
2. Statement letter of no financial interest dated June 06, 2023, issued by manufacturer, signed and sealed by Anthony Lynn Miller, P.E.

**G. OTHERS**

1. Notice of Acceptance No. **21-0205.04**, issued to PGT Industries, Inc., for their **Series “5470” Vinyl Sliding Glass Door (Reinforced) – N.I.**, approved on 03/25/21 and expiring on 04/21/26.



Ishaq I. Chanda, P.E.  
Product Control Unit Supervisor  
NOA No. 26-0126.02  
Expiration Date: April 21, 2031  
Approval Date: March 05, 2026

NOTICE OF ACCEPTANCE: EVIDENCE SUBMITTED

**5. NEW EVIDENCE SUBMITTED**

**A. DRAWINGS**

1. Drawing No. **MD-5470.0 E**, titled "Vinyl Sliding Glass Door (NI)", sheets 1 through 21 of 21, dated 10/05/15 and last revised on 01/21/26, prepared by manufacturer, signed and sealed by Anthony Lynn Miller, P.E.  
(The revision consists of removal FBC 2020 reference and Co. address change)

**B. TESTS**

1. None.

**C. CALCULATIONS**

1. None

**D. QUALITY ASSURANCE**

1. Miami-Dade Department of Regulatory and Economic Resources (RER)

**E. MATERIAL CERTIFICATIONS**

1. Notice of Acceptance No. **24-0618.01**, issued to **Vision Extrusions Group Limited**, for their **White Rigid PVC Exterior Extrusions for Windows and Doors**, approved on 03/31/22, expiring on 09/30/29.
2. Notice of Acceptance No. **24-0618.02**, issued to **Vision Extrusions Group Limited**, for their **Painted or laminated White Rigid PVC Exterior Extrusions for Windows and Doors**, expiring on 09/30/29.
3. Notice of Acceptance No. **23-0830.05**, issued to **Vision Extrusions Group Limited**, for their **VE 1000 Tan 202 and Lighter Shades (Non-White) Rigid PVC Exterior Extrusions for Windows and Doors**, expiring on 12/29/26.
4. Notice of Acceptance No. **24-0401.07**, issued to **Vision Extrusions Group Limited**, for their **Black and lighter shades of cap coated Rigid PVC Exterior Extrusions for Windows and Doors**, expiring on 07/28/27.
5. Notice of Acceptance No. **23-0821.09** issued to **Vision Extrusions Group Limited**. for their **"Tan 3040 & light shade (non-white) White Rigid PVC Exterior Extrusions for Windows and Doors"**, expiring on 02/04/26.

**F. STATEMENTS (items #2 and 3 submitted in other previous approval)**

1. Statement letter of product compliance with **FBC 8<sup>th</sup> Edition (2023)** and No financial interest, dated January 21, 2026, issued by manufacturer, signed and sealed by Anthony Lynn Miller, P.E.
2. Statement letter dated 02/17/25 issued by manufacturer requesting renewal with company name change to PGT industries, LLC, signed and sealed by Anthony Lynn Miller, P.E.
3. e-mail dated 12/23/24 sent by Lynn Miller (PGT Code Compliance Manager), consists of PGT innovation form 8-k filed w/SEC, PGT innovation form 10-K filed w/SEC and Exhibit 21(Form 10-K); PGT innovation's list of subsidiaries.



Ishaq I. Chanda, P.E.  
Product Control Unit Supervisor  
NOA No. 26-0126.02  
Expiration Date: April 21, 2031  
Approval Date: March 05, 2026

NOTICE OF ACCEPTANCE: EVIDENCE SUBMITTED

**G. OTHERS**

1. This NOA revises & renews NOA # 23-0710.09, issued to **PGT Industries, Inc.**, for their **Series "5470" Vinyl Sliding Glass Door (Reinforced) – N.I.**, expiring on 04/21/26.
2. Article of conversion of PGT Industries, Inc to PGT industries, LLC pdf provided on 12/24/24 by Ms. April Lee, Assistant General Counsel.
3. Florida Department of State, Division of Corporation listing # L2400142070 of PGT Industries LLC as active status since 12/17/24.
4. Florida Department of State, Division of Corporation listing # F03387 of PGT Industries, Inc. as Inactive status.
5. PGT Name change organization chart layout prepared by RER (for file use only).

*Ishaq I. Chanda*

---

**Ishaq I. Chanda, P.E.**  
**Product Control Unit Supervisor**  
**NOA No. 26-0126.02**  
**Expiration Date: April 21, 2031**  
**Approval Date: March 05, 2026**

# SERIES 5470, NON-IMPACT RESISTANT SLIDING GLASS DOOR INCLUDING POCKETS & 90°/135° CORNERS

IMPACT RATING  
NOT RATED FOR MISSILE  
IMPACT RESISTANCE

DESIGN PRESSURE RATING  
SEE TABLES 1, 2 & B1, B2  
ON SHEETS 7 & 8

**GENERAL NOTES:**

- GLAZING TYPE OPTIONS: SEE GLAZING DETAILS ON SHEET 10.
- DESIGN PRESSURES:
  - NEGATIVE DESIGN LOADS BASED ON TESTED PRESSURE AND GLASS PER ASTM E1300.
  - POSITIVE DESIGN LOADS BASED ON WATER TEST PRESSURE AND GLASS PER ASTM E1300.
  - DESIGN LOADS ARE BASED ON ALLOWABLE STRESS DESIGN, ASD.
- ANCHORAGE: THE 33-1/3% STRESS INCREASE HAS NOT BEEN USED IN THE DESIGN OF THIS PRODUCT. MATERIALS, INCLUDING BUT NOT LIMITED TO STEEL SCREWS, THAT COME INTO CONTACT WITH OTHER DISSIMILAR MATERIALS SHALL MEET THE REQUIREMENTS OF THE FLORIDA BUILDING CODE (FBC).
- SHUTTERS ARE NOT REQUIRED PER FBC REQUIREMENTS, AS APPLICABLE.
- INSTALLATION SCREWS & FRAME SPLICES TO BE SEALED WITH NARROW JOINT SEALANT. OVERALL SEALING/FLASHING STRATEGY FOR WATER RESISTANCE OF INSTALLATION SHALL BE DONE BY OTHERS AND IS BEYOND THE SCOPE OF THESE INSTRUCTIONS.
- REFERENCES (NOA'S): DEWALT ULTRACON+, DEWALT/ELCO CRETEFLEX & AGGRE-GATOR ANCHOR NOA'S, VISION EXTRUSION, LTD. VE 2000 TAN 202 AND LIGHTER SHADES (NON-WHITE) RIGID CELLULAR PVC, WHITE RIGID PVC EXTERIOR EXTRUSIONS FOR WINDOWS AND DOORS.
- REFERENCES (TEST REPORTS): FTL-6337, 6338, 8646-8649, 8652 & 8717; QAI 22-1081, QA1-NOK-0004; EXOVA-10-002-792(A) & 10-006-10231; CAMBRIDGE 535753-09;
- THIS PRODUCT HAS BEEN DESIGNED & TESTED TO COMPLY WITH THE REQUIREMENTS OF THE FBC, INCLUDING THE HIGH VELOCITY HURRICANE ZONE (HVHZ). THE RIGID WHITE, BROWN & TAN PVC MANUFACTURED BY VISION EXTRUSION, LTD. HAS BEEN TESTED TO COMPLY WITH THE FLORIDA BUILDING CODE FOR PLASTICS, (COMPONENT REQUIREMENTS).
- DOOR SIZES MUST BE VERIFIED FOR COMPLIANCE WITH EGRESS REQUIREMENTS OF THE FBC, AS APPLICABLE.
- DRAWINGS DEPICT EXTERIOR-GLAZING, HOWEVER INTERIOR-GLAZING MAY BE SUBSTITUTED.

**ANCHOR NOTES:**

- FOR CONCRETE/CMU SUBSTRATE APPLICATIONS IN MIAMI-DADE COUNTY, USE ONLY MIAMI-DADE COUNTY APPROVED ANCHORS. SEE TABLE A ON THIS SHEET FOR EMBEDMENT, EDGE DISTANCE AND SUBSTRATE REQUIREMENTS.
- FOR OTHER SUBSTRATE APPLICATIONS SEE TABLE A ON THIS SHEET.
- WOOD BUCKS DEPICTED AS 1X ARE LESS THAN 1-1/2" THICK. PROPERLY SECURED, 1X WOOD BUCKS ARE OPTIONAL IF UNIT IS INSTALLED DIRECTLY TO SOLID CONCRETE OR CMU. WOOD BUCKS DEPICTED AS 2X ARE 1-1/2" THICK OR GREATER. 1X AND 2X BUCKS (WHEN USED) SHALL BE DESIGNED TO PROPERLY TRANSFER LOADS TO THE STRUCTURE. BUCK DESIGN AND INSTALLATION IS THE RESPONSIBILITY OF THE ENGINEER OR ARCHITECT OF RECORD & TO BE REVIEWED BY THE BUILDING OFFICIAL.
- METAL SUBSTRATE TO MEET MIN. STRENGTH AND THICKNESS REQUIREMENTS PER THE FBC AND TO BE REVIEWED BY THE AUTHORITY HAVING JURISDICTION.
- IF SILL IS TIGHT TO SUBSTRATE, GROUT OR OTHER MATERIAL IS NOT REQUIRED. IF USED, NON-SHRINK, NON-METALLIC GROUT, MAX. 1/4" THICK & 3400 PSI MIN., (DONE BY OTHERS) MUST FULLY SUPPORT THE ENTIRE LENGTH OF THE SILL THAT IS NOT TIGHT TO THE SUBSTRATE, AND TRANSFER SHEAR LOAD TO SUBSTRATE. IF SUBSTRATE IS WOOD, 30# FELT PAPER OR MASTIC IS REQUIRED BETWEEN THE GROUT AND WOOD SUBSTRATE, OR AS APPROVED BY THE AUTHORITY HAVING JURISDICTION.

TABLE A:

Group	Anchor	Substrate	Frame Member	Min. Edge Distance	Min. Embedment	
A	#12, steel SMS (G5) or 410 S.S. SMS (min. 11 threads/in)	P.T. Southern Pine, (SG=0.55)	Head/Sill/Jamb/P-hook	9/16"	1-3/8"	
		Aluminum, 6063-T5	Head/Sill/Jamb/P-hook	3/8"	1/8"	
		Steel, A36, (0.060" min.)	Head/Sill/Jamb/P-hook	3/8"	0.060"	
		Steel Stud, A653 Gr. 33	Head/Sill/Jamb/P-hook	3/8"	0.071" (14 Ga.)	
	1/4" DeWalt Ultracon+	P.T. Southern Pine, (SG=0.55)	Jamb	1"	1-3/8"	
	1/4" Elco 410 S.S. CreteFlex		Head/Sill/Jamb/P-hook	1"	1-3/8"	
B	#12, steel wood screw (G5)	P.T. Southern Pine, (SG=0.55)	Head/Sill/Jamb/P-hook	9/16"	1-3/8"	
C	1/4" DeWalt Ultracon+	Concrete, (min. 3 ksi)	Head/Sill/Jamb	1-1/2"	1-3/8"	
			P-hook	1"	1-3/8"	
	1/4" DeWalt/Elco 410 S.S. CreteFlex	Concrete, (min. 3.35 ksi)	UngROUTED CMU, (ASTM C-90)	Jamb/P-hook	1"	1-1/4"
			UngROUTED CMU, (ASTM C-90)	Jamb/P-hook	1-3/4"	1-1/4"
			Head/Sill/Jamb	1-3/16"	1-3/4"	
			P-hook	1"	1-3/4"	
1/4" DeWalt/Elco 18-8 S.S. Aggre-Gator	Concrete, (min. 2.22 ksi)	Head/Sill/Jamb/P-hook	1-1/2"	1-3/8"		
		UngROUTED CMU, (ASTM C-90)	Jamb/P-hook	2"	1-1/4"	
		P.T. Southern Pine, (SG=0.55)	Head/Sill/Jamb/P-hook	1"	1-3/8"	
D	1/4" DeWalt Ultracon+	Concrete, (min. 3 ksi)	Head/Sill/Jamb/P-hook	2-1/2"	1-3/8"	
			UngROUTED CMU, (ASTM C-90)	Jamb/P-hook	2-1/2"	1-1/4"
	1/4" DeWalt/Elco 410 S.S. CreteFlex	Concrete, (min. 3.35 ksi)	Head/Sill/Jamb	2-1/2"	1-3/4"	
			P-hook	2-1/2"	1-3/8"	
		UngROUTED CMU, (ASTM C-90)	Jamb/P-hook	2-1/2"	1-1/4"	

- MIN. OF 3 THREADS BEYOND THE METAL SUBSTRATE. METAL SUBSTRATE TO MEET MIN. STRENGTH AND THICKNESS REQUIREMENTS PER CURRENT FLORIDA BUILDING CODE AND TO BE REVIEWED BY THE AUTHORITY HAVING JURISDICTION. ALL ANCHOR HEAD TYPES APPLICABLE.
- "UNGROUTED CMU" VALUES MAY BE USED FOR GROUTED CMU APPLICATIONS.
- FOR THE MINIMUM STRENGTHS OF ANCHORS AND SUBSTRATES, SEE TABLE F, SHEET 21.
- ALL ANCHOR HEAD TYPES ARE APPLICABLE.

**INSTRUCTIONS:**

- KNOWING THE REQUIRED DESIGN PRESSURE OF THE OPENING, THE ANCHOR REQUIREMENTS FOR THE SLIDING GLASS DOORS MAY BE DETERMINED FROM DESIGN PRESSURE TABLES 1 OR 2, DEPENDING ON THE GLASS/REINFORCEMENT.
- LOCATE THE SLIDING GLASS DOOR SIZE ON THE TABLE, USING THE FRAME HEIGHT AND THE NOMINAL PANEL WIDTH IF YOUR EXACT SIZE IS NOT LISTED, ROUND UP TO THE NEXT GREATER LISTED WIDTH AND/OR HEIGHT.
- CHOOSE WHICH ANCHOR GROUP (A-D) IS MOST APPLICABLE. ANCHORS ARE DEFINED IN TABLE A, THIS SHEET, ALONG WITH THE CORRESPONDING SUBSTRATE, MINIMUM EMBEDMENT AND MINIMUM EDGE DISTANCE.
- FROM THE DESIGN PRESSURE TABLES (TABLES 1 OR 2), VERIFY THAT THE OPENING'S REQUIRED DESIGN PRESSURE IS MET OR EXCEEDED. USE THE ANCHOR QUANTITIES SHOWN.
- INSTALL AS PER THE GUIDELINES OF THIS SHEET-SET.
- ADDITIONALLY, SEE THE EXAMPLE ON SHEET 9.

CODES / STANDARDS USED:

- 2023 FLORIDA BUILDING CODE (FBC), 8TH EDITION
- ASTM E1300-09
- ANSI/AF&PA NDS-2018 FOR WOOD CONSTRUCTION
- ALUMINUM DESIGN MANUAL, ADM-2020
- AISI S100-16
- AISC 360-16

GENERAL NOTES.....	1
EXAMPLE CONFIGS.....	2
INSTALL DETAILS.....	3-6
DP/ANCHOR TABLES.....	7-8
EXAMPLE.....	9
GLAZING DETAILS.....	10
ANCHOR LOCATIONS.....	11-16
PANEL TYPES.....	17
EXTRUSIONS.....	18
ACCESSORIES.....	19
SCREEN DETAILS.....	20
PARTS LIST.....	21

PRODUCT REVISED  
as complying with the Florida  
Building Code  
Acceptance No 26-0126-02  
Expiration Date 4/24/2031  
By Shag J. Ch...  
Miami Dade Product Control

Revision:

PREPARED BY A. LYNN MILLER 1070 TECHNOLOGY DRIVE N. VENICE, FL 34275 (941) 480-1600	REGISTRATION #29296 10/05/15 Date	JENS ROSOWSKI Drawn By	MD-5470.0 No. DWG	Rev.
				E
<b>PGT</b> Custom Windows and Doors 3400 PRECISION DRIVE N. VENICE, FL 34275 (941) 480-1600	VINYL SLIDING GLASS DOOR (NI)	GENERAL NOTES	1 OF 21 No. Sheet	SGD-5470
				Series Desc. Title

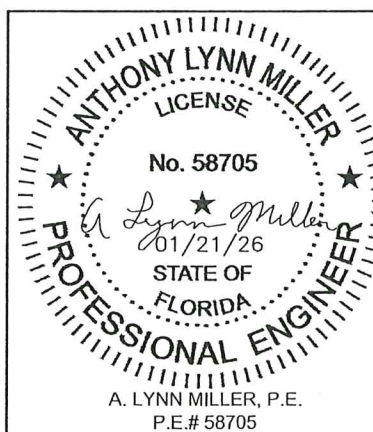

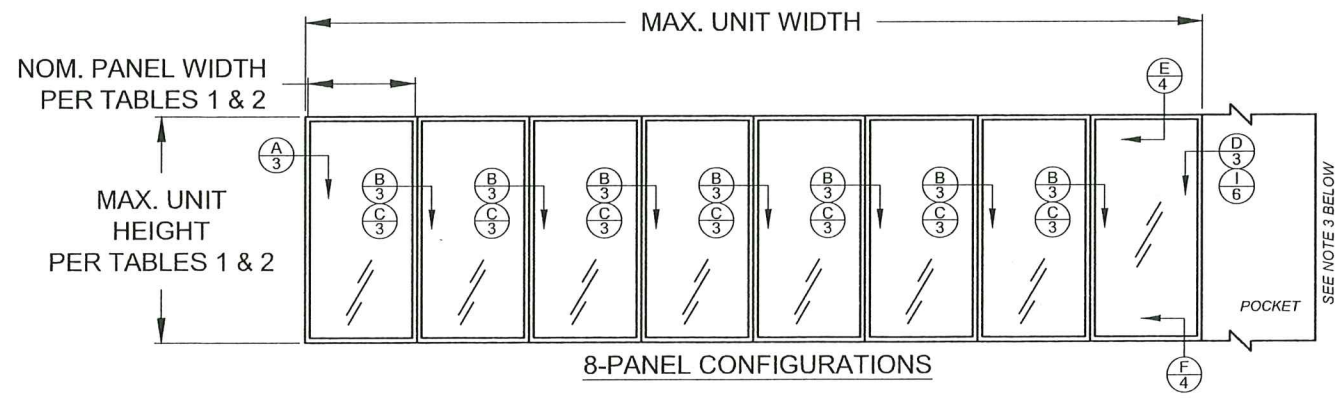
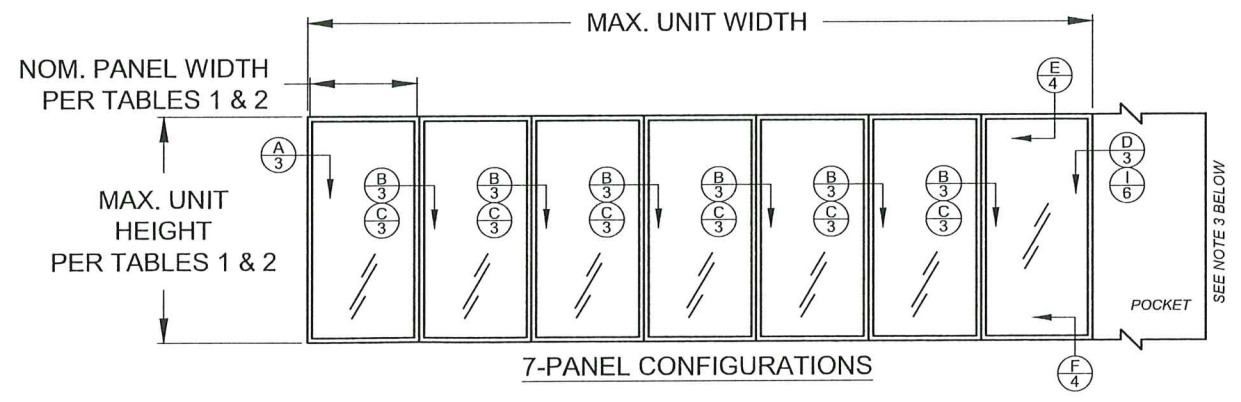
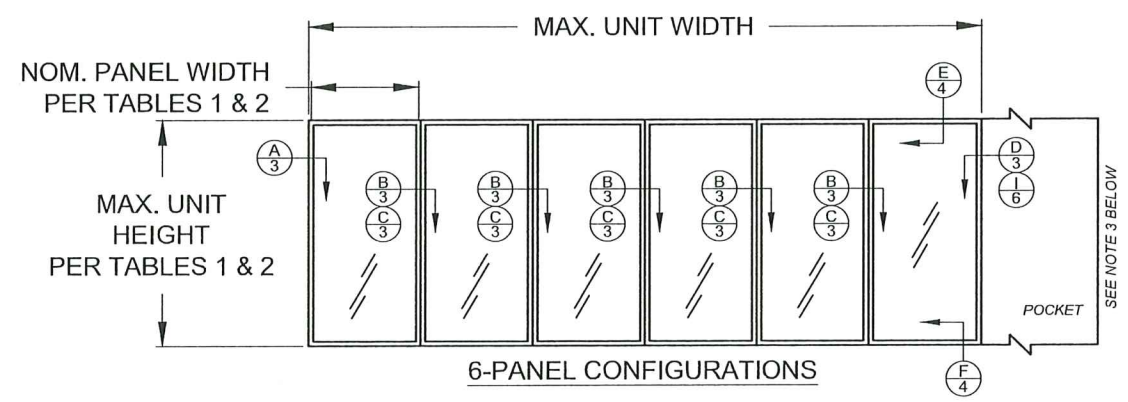
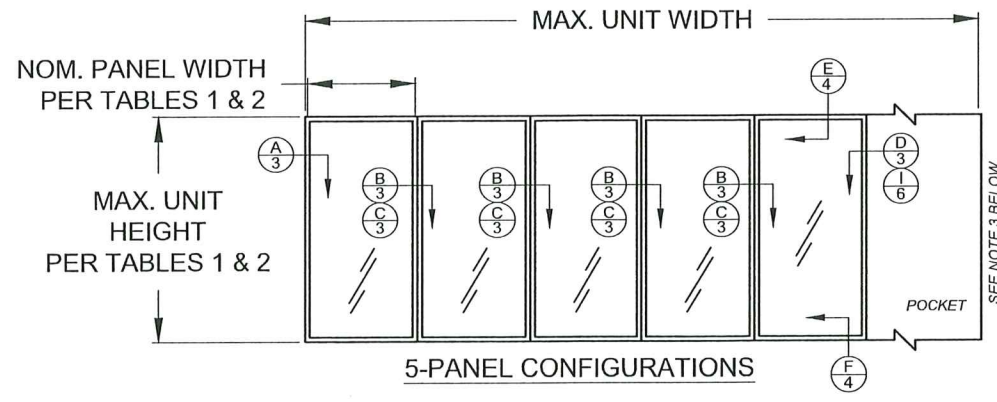
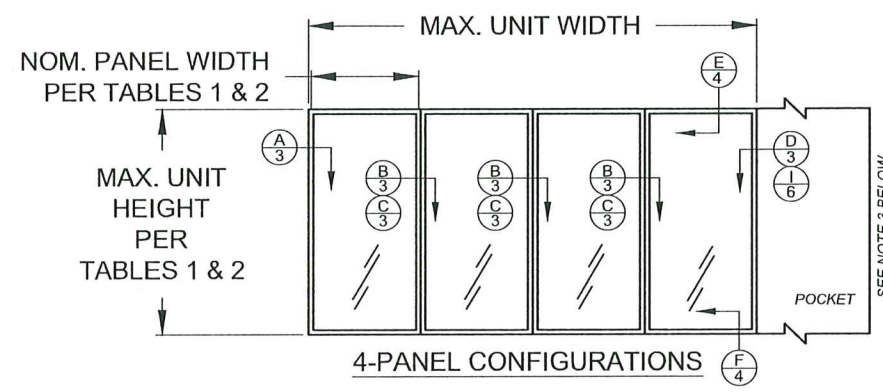
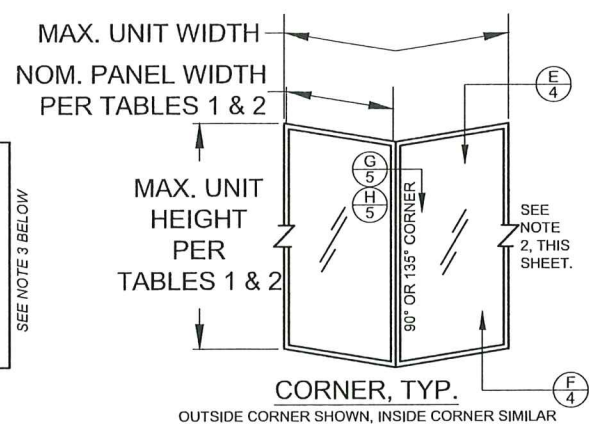
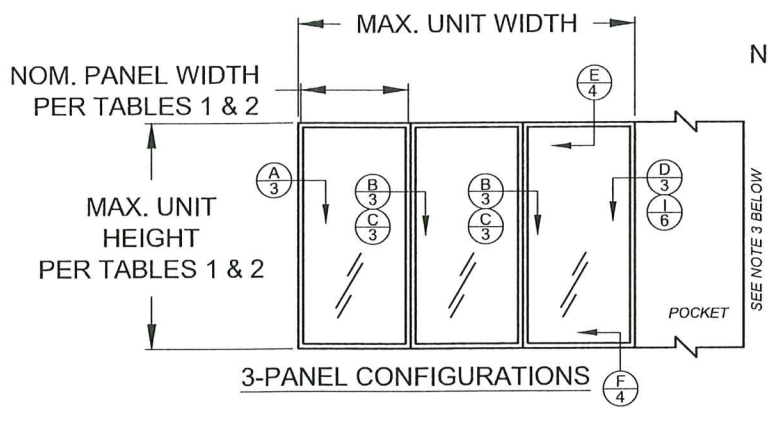
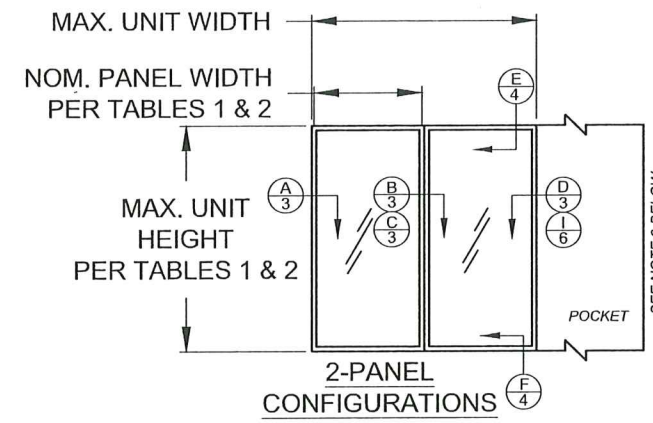
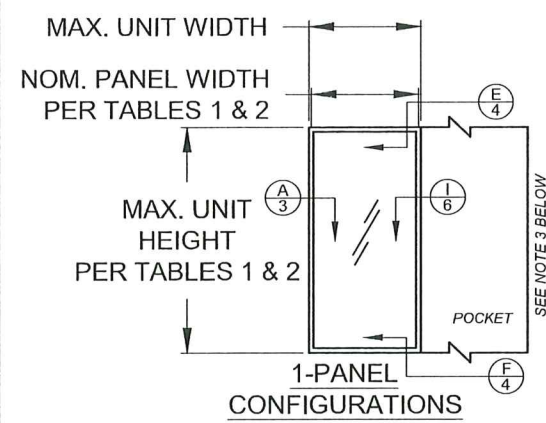

DETAIL LETTER  
X #  
SHEET NUMBER

DLO WIDTH = NOM. PANEL WIDTH - 8-9/16"  
 NOM. PANEL WIDTH = PANEL WIDTH + 1-3/16"  
 DLO HEIGHT = DOOR HEIGHT - 11-1/16"  
 PANEL HEIGHT = DOOR HEIGHT - 2-1/2"

**CONFIGURATIONS NOTES:**

- 1) ALL CONFIGURATIONS SHOWN ARE ALSO AVAILABLE AS POCKET CONFIGURATIONS AT EITHER OR BOTH JAMB LOCATIONS. EXAMPLE: 4-PANEL XXXX IN POCKET (p) CONFIGURATION CAN BE pXXXXp, pXXXX OR XXXXp. OXXX IN POCKET CONFIGURATION CAN BE OXXXp.
- 2) 90° & 135° CORNER CONFIGURATIONS ARE A COMBINATION OF ANY 2 STRAIGHT CONFIGURATIONS.
- 3) POCKET WALL OR CAVITY IS NOT PART OF THIS APPROVAL AND IS TO BE DESIGNED BY OTHERS AND REVIEWED BY THE AUTHORITY HAVING JURISDICTION.
- 4) FOR NOM. PANEL WIDTH, SEE TABLES 1 & 2.
- 5) MAX. ALLOWABLE FRAME SQUARE FOOTAGE = 472.656 FT<sup>2</sup>

"X" = OPERABLE PANEL  
 "O" = INOPERABLE PANEL  
 "p" = POCKET

**PRODUCT REVISION**  
 as complying with the Florida Building Code  
 Acceptance No 26-0126-02  
 Expiration Date 4/21/2031  
 By Ishing J. Chan  
 Miami Dade Product Control

PREPARED BY A. LYNN MILLER 1070 TECHNOLOGY DRIVE N. VENICE, FL 34275 (941) 480-1600 REGISTRATION #29296	Date	10/05/15	Rev.	E
	Drawn By	JENS ROSOWSKI	DWG No.	MD-5470.0
VINYL SLIDING GLASS DOOR (NI) EXAMPLE CONFIGURATIONS		Sheet	2 OF 21	
PGT Custom Windows and Doors 3400 PRECISION DRIVE N. VENICE, FL 34275 (941) 480-1600		Series	SGD-5470	

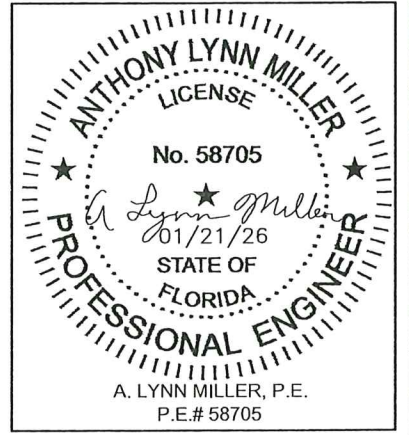

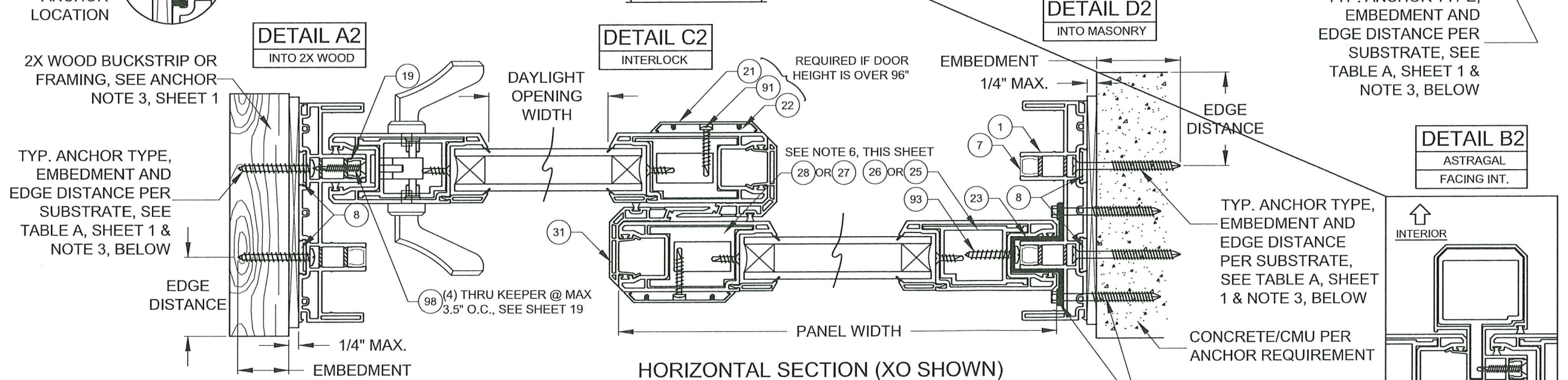
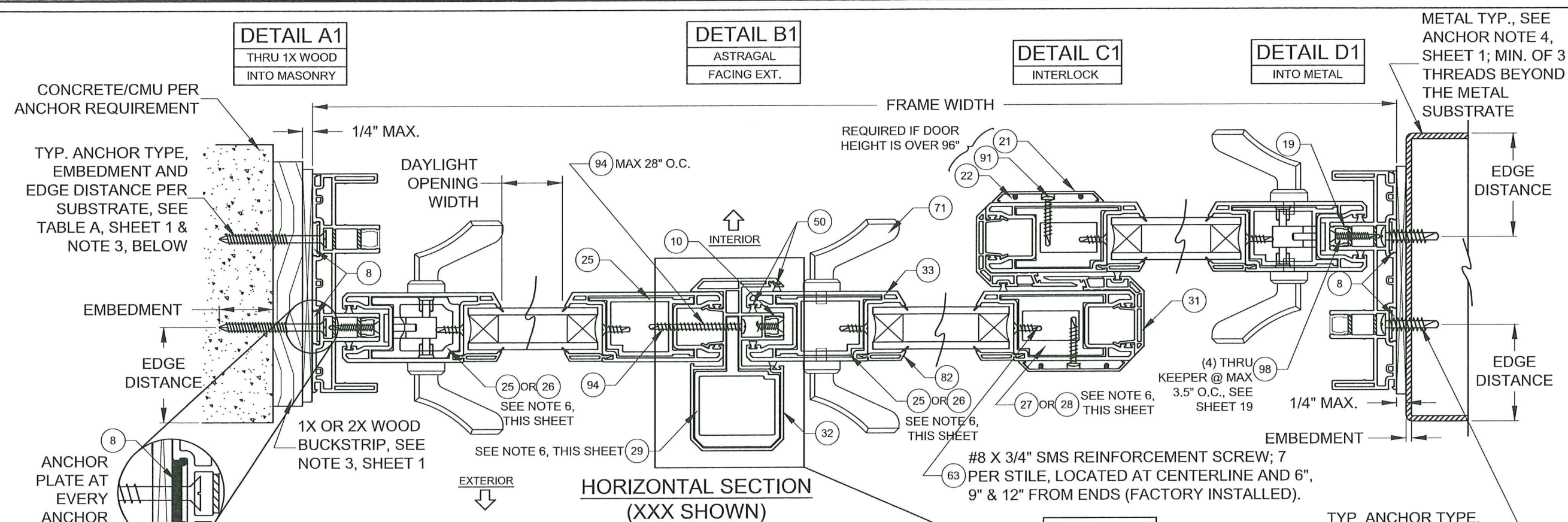

- NOTES**
- 1) DETAILS APPLY TO 2, 3 AND 4 TRACK CONFIGURATIONS.
  - 2) REFER TO ANCHOR NOTES, SHEET 1.
  - 3) SEE SHEET 13 FOR ANCHOR LOCATION & SPACING, FOR ANCHOR QUANTITIES, SEE TABLES 1 & 2.
  - 4) CONTINUOUS ANCHOR PLATE, ITEM #8, IS REQUIRED AT ALL FRAME ANCHOR LOCATIONS.
  - 5) PANEL WIDTH DOES NOT INCLUDE INTERLOCK OR ASTRAGAL ADD-ON.
  - 6) SEE TABLES 1 & 2 FOR REINFORCEMENT REQUIREMENTS. ALL REINFORCEMENTS ARE APPROXIMATELY THE FULL LENGTH OF THE EXTRUSION. REFER TO TEST REPORTS FOR EXACT DIMENSIONS.
  - 7) SEE SHEET 20 FOR SCREEN DETAILS.

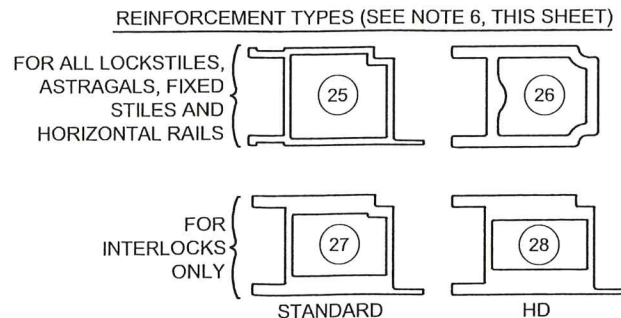

DLO WIDTH = NOM. PANEL WIDTH - 8-9/16"  
 DLO HEIGHT = DOOR HEIGHT - 11-1/16"  
 PANEL HEIGHT = DOOR HEIGHT - 2-1/2"

**PRODUCT REVISED**  
 as complying with the Florida Building Code  
 Acceptance No. 26-0126.02  
 Expiration Date 4/21/2031  
 By: *Isang J. Cho*  
 Miami Dade Product Control

PREPARED BY A. LYNN MILLER 1070 TECHNOLOGY DRIVE N. VENICE, FL 34275 (941) 480-1600 REGISTRATION #29296	Date	10/05/15	Rev.	E
	Drawn By	JENS ROSOWSKI	MD-5470.0	
<b>PGT</b> Custom Windows and Doors 3400 PRECISION DRIVE N. VENICE, FL 34275 (941) 480-1600	Series Desc.	VINYL SLIDING GLASS DOOR (NI)	Sheet	3 OF 21
	Horizontal Cross Sections	HORIZONTAL CROSS SECTIONS	DWG No.	MD-5470

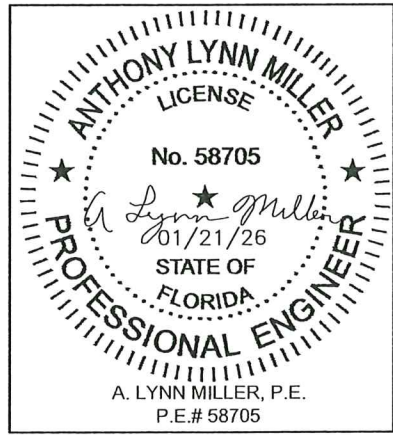

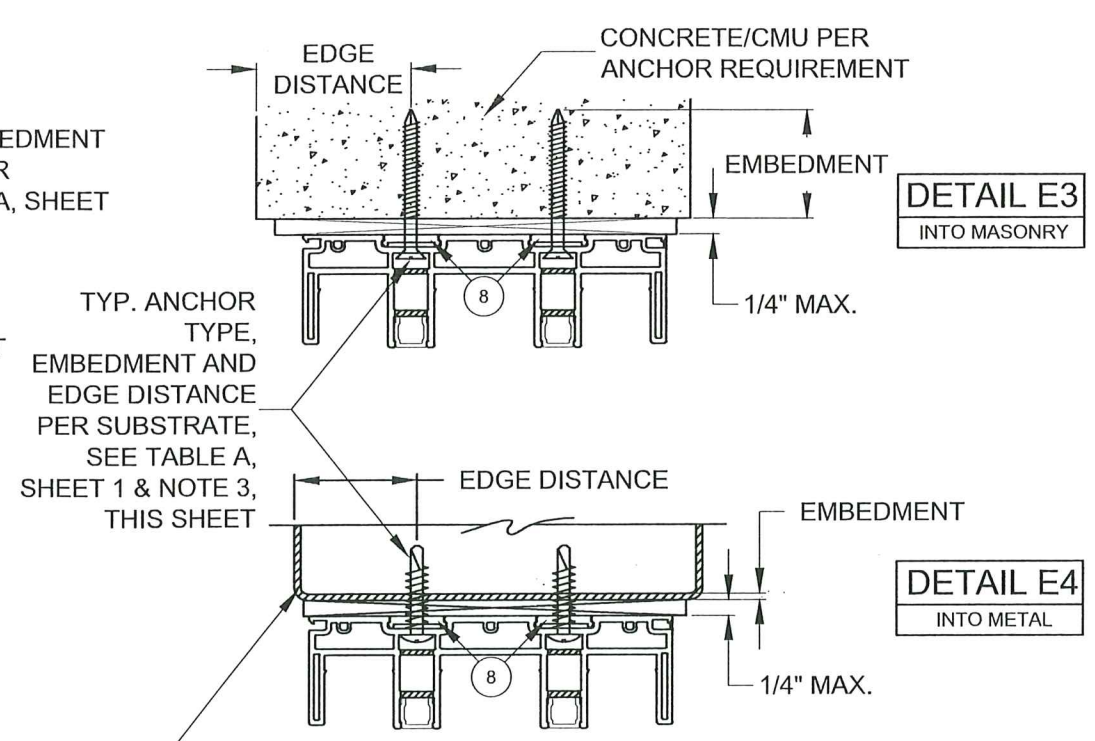
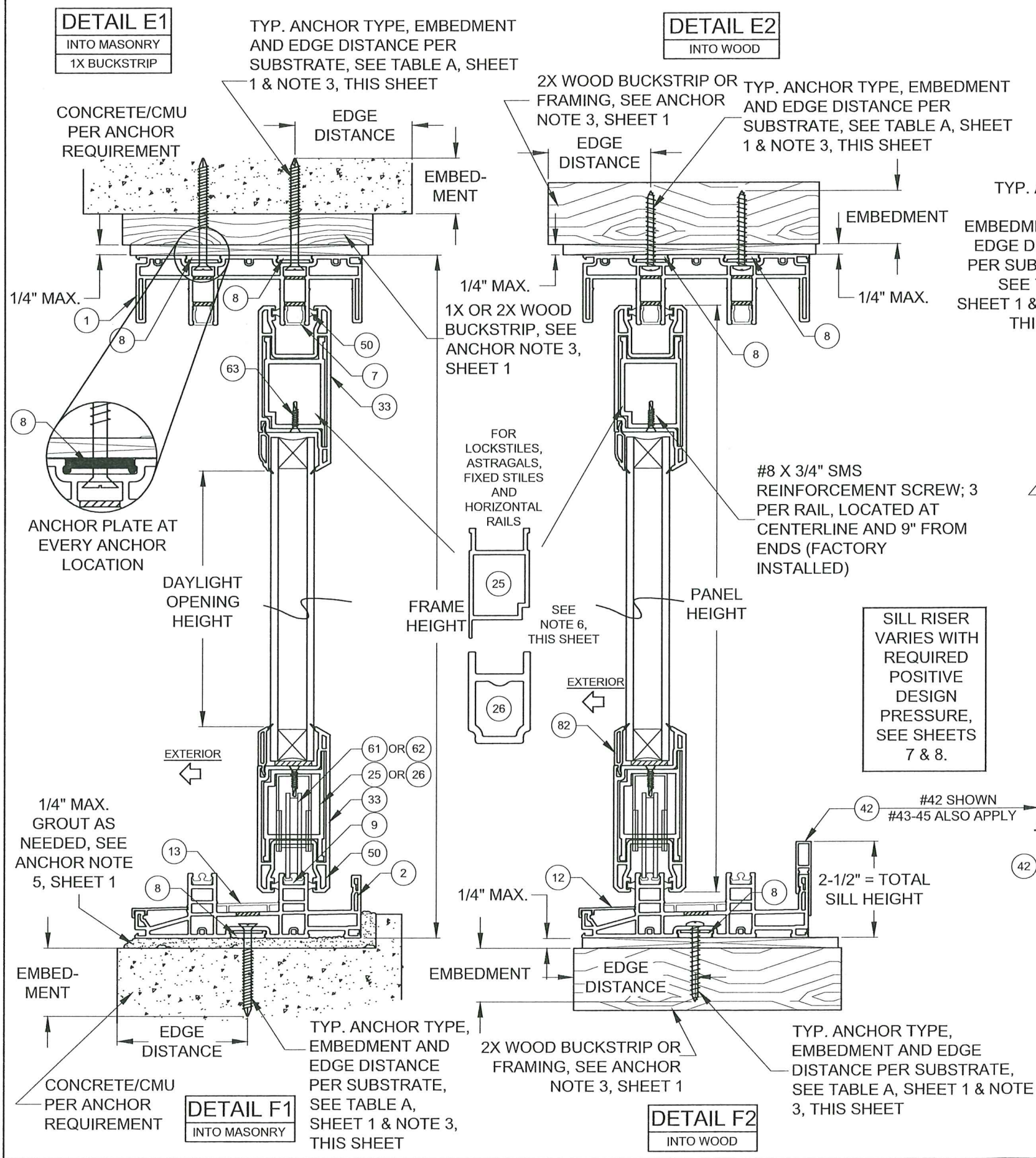

DADE APPROVED MULLION, FBC COMPLIANT ALUMINUM/STEEL FRAMING OR STEEL STUD. MAY BE VERTICAL OR HORIZONTAL. SEE SUBSTRATE PROPERTIES, TABLE A, SHEET 1

DLO WIDTH = NOM. PANEL WIDTH - 8-9/16"  
 DLO HEIGHT = DOOR HEIGHT - 11-1/16"  
 PANEL HEIGHT = DOOR HEIGHT - 2-1/2"

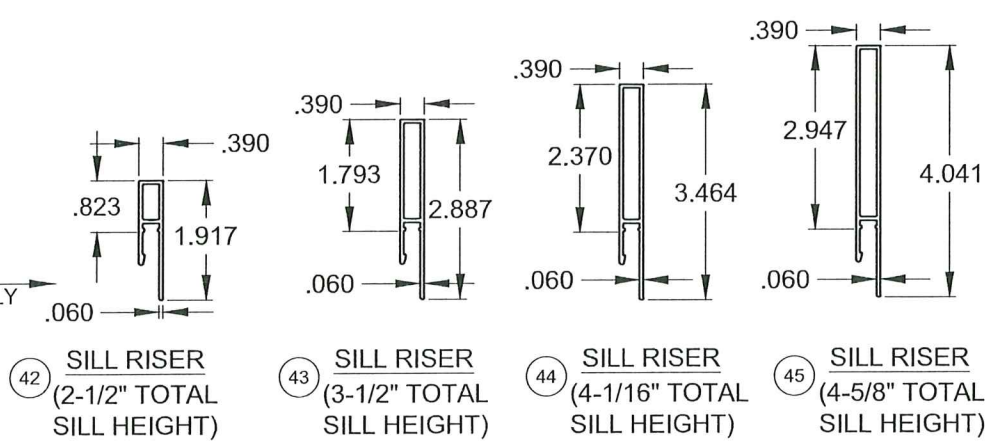

**NOTES**

- 1) DETAILS APPLY TO 2, 3 AND 4 TRACK CONFIGURATIONS.
- 2) REFER TO ANCHOR NOTES, SHEET 1.
- 3) SEE SHEETS 11 & 12 FOR ANCHOR LOCATION & SPACING, FOR ANCHOR QUANTITIES, SEE TABLES 1 & 2.
- 4) CONTINUOUS ANCHOR PLATE, ITEM #8, IS REQUIRED AT ALL FRAME ANCHOR LOCATIONS.
- 5) SEE SHEET 20 FOR SCREEN DETAILS.
- 6) SEE TABLES 1 & 2 FOR REINFORCEMENT REQUIREMENTS. ALL REINFORCEMENTS ARE APPROXIMATELY THE FULL LENGTH OF THE EXTRUSION. REFER TO TEST REPORTS FOR EXACT DIMENSIONS.

PRODUCT REVISED as complying with the Florida Building Code Acceptance No. 26-0126.02 Expiration Date 4/21/2031  
 By *Anthony Lynn Miller*  
 Miami Dade Product Control

PREPARED BY A. LYNN MILLER 1070 TECHNOLOGY DRIVE N. VENICE, FL 34275 (941) 480-1600 REGISTRATION #29296	Date	10/05/15	Rev.	E
	Drawn By	JENS ROSOWSKI	DWG No.	MD-5470.0
<b>PGT</b> Custom Windows and Doors 3400 PRECISION DRIVE N. VENICE, FL 34275 (941) 480-1600	VINYL SLIDING GLASS DOOR (NI)		Sheet	4 OF 21
	VERTICAL CROSS SECTIONS		Series Desc.	SGD-5470

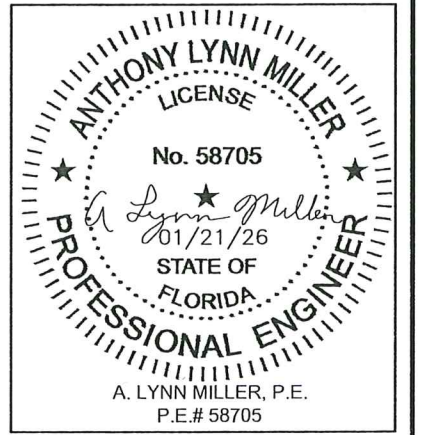

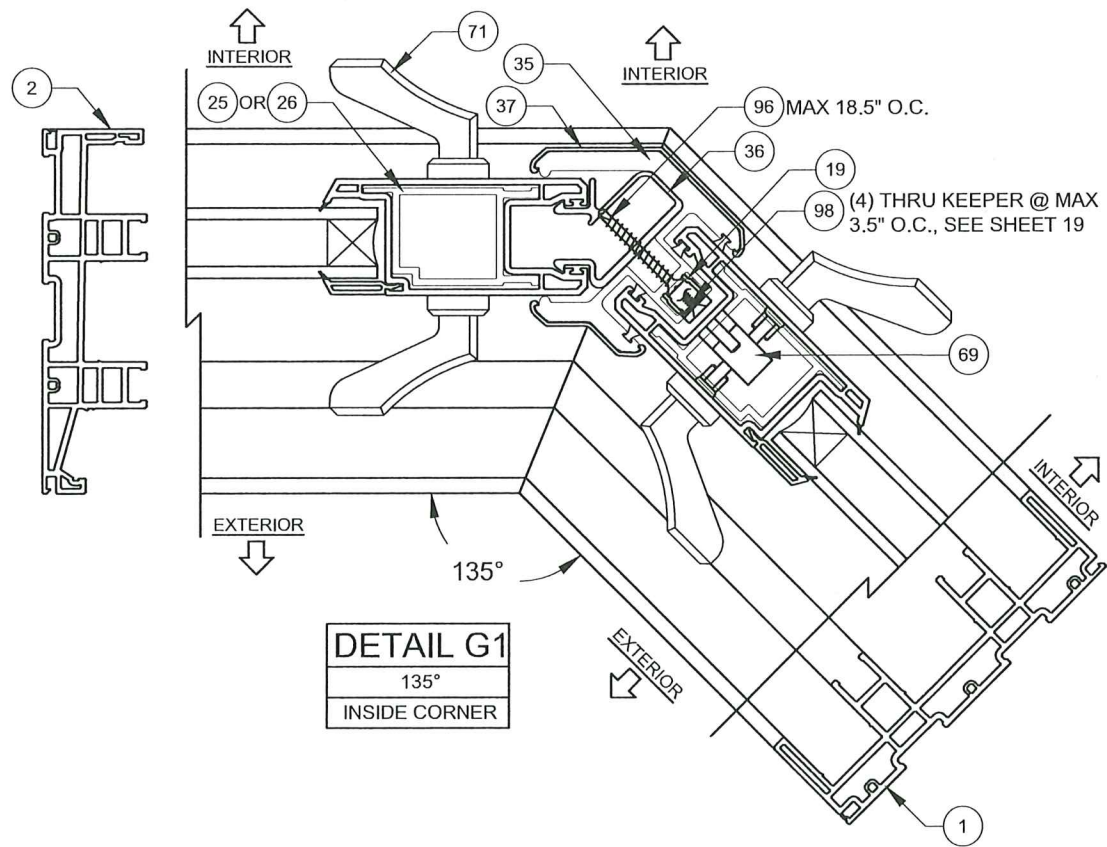

**DETAIL G1**  
135°  
INSIDE CORNER

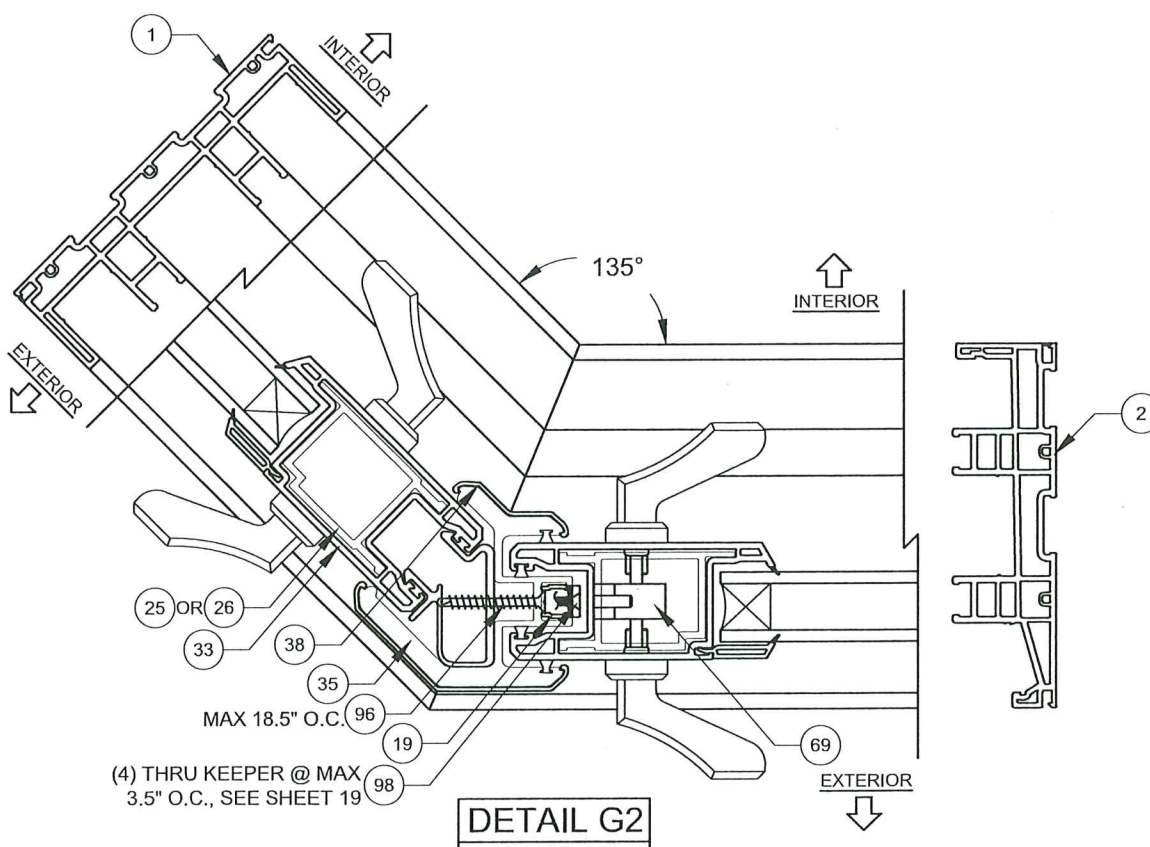

**DETAIL G2**  
135°  
OUTSIDE CORNER

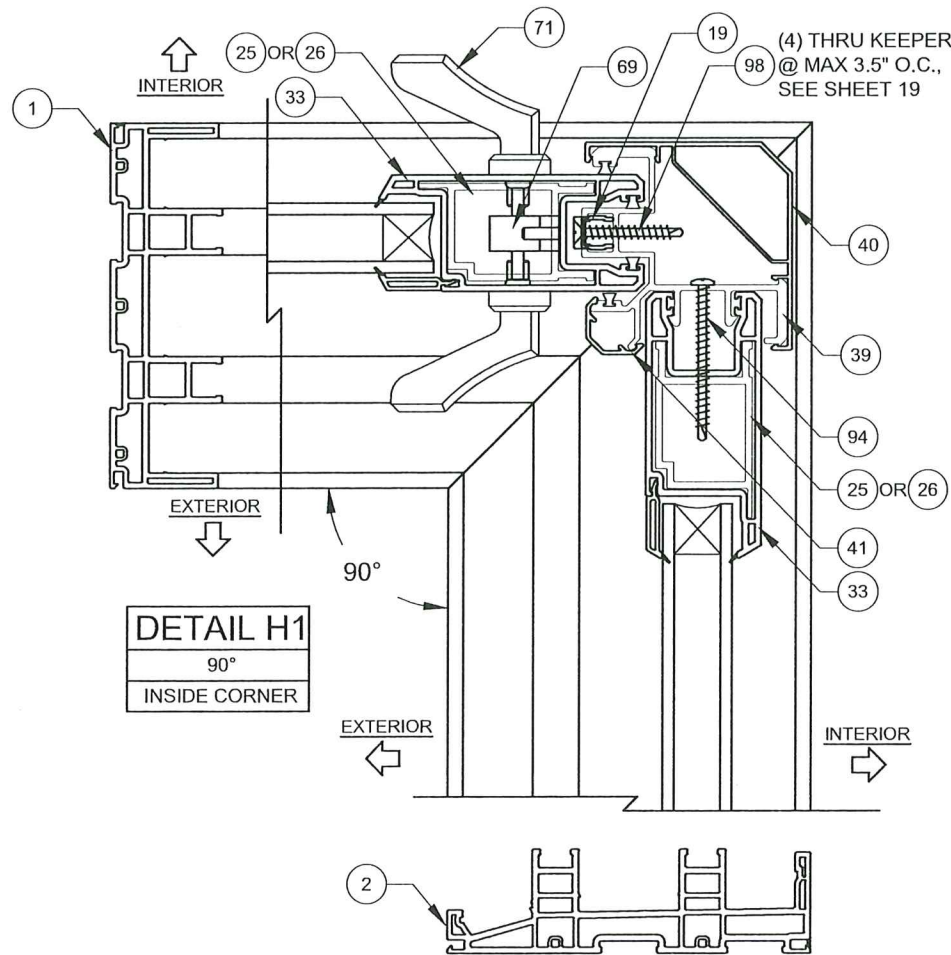

**DETAIL H1**  
90°  
INSIDE CORNER

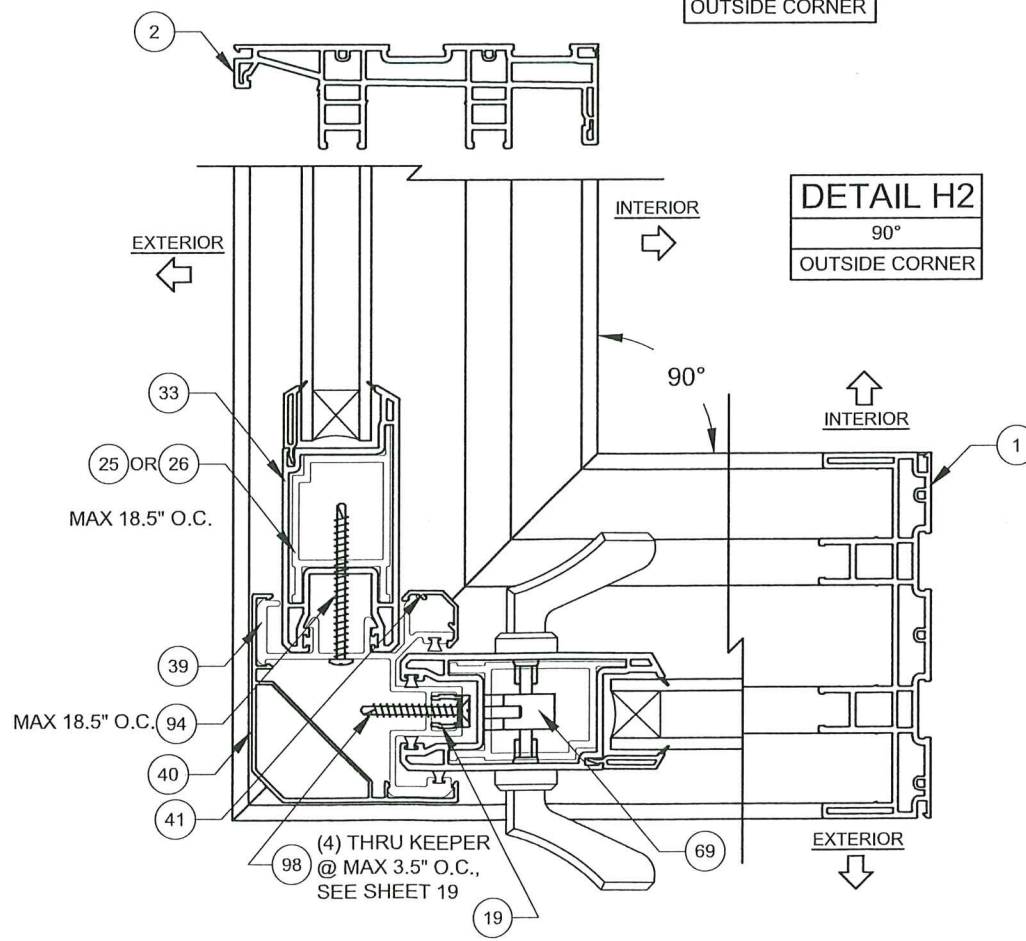

**DETAIL H2**  
90°  
OUTSIDE CORNER

**NOTES**

- 1) DETAILS APPLY TO 2, 3 AND 4 TRACK CONFIGURATIONS.
- 2) SEE SHEETS 14 & 15 FOR ANCHOR LOCATION & SPACING, FOR ANCHOR QUANTITIES, SEE TABLES 1 & 2.
- 3) CORNER ASTRAGAL MAY BE EITHER TO THE INTERIOR OR EXTERIOR, DEPENDING ON CONFIGURATION.

**PRODUCT REVISED**  
as complying with the Florida  
Building Code  
Acceptance No 26-0126-02  
Expiration Date 4/21/2031  
By Anthony L. Miller  
Miami Dade Product Control

Revision:

PREPARED BY A. LYNN MILLER 1070 TECHNOLOGY DRIVE N. VENICE, FL 34275 (941) 480-1600	REGISTRATION #29296	10/05/15	Rev.	E
	VINYL SLIDING GLASS DOOR (NI)	Date	JENS ROSOWSKI	MD-5470.0
<b>PGT</b> Custom Windows and Doors 3400 PRECISION DRIVE N. VENICE, FL 34275 (941) 480-1600	CORNER HORIZ. X-SECTION	Drawn By	DWG No.	5 OF 21
	SGD-5470	Sheet	5 OF 21	5 OF 21
Series Desc. Title		5 OF 21		

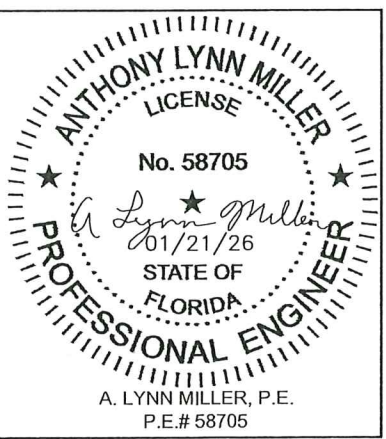

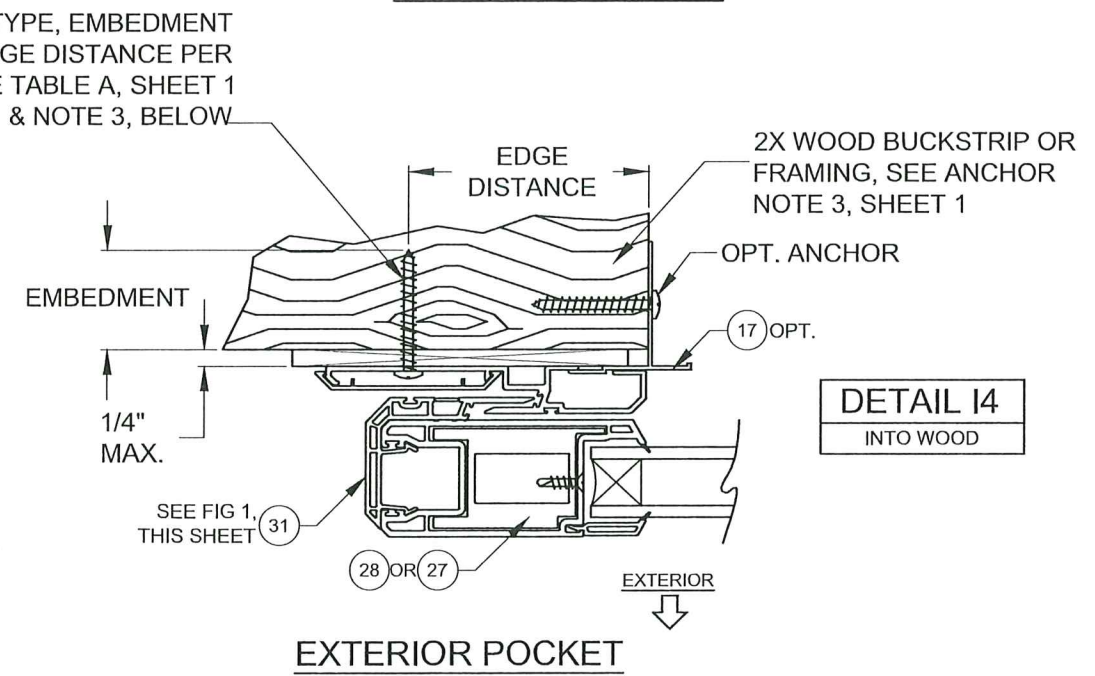
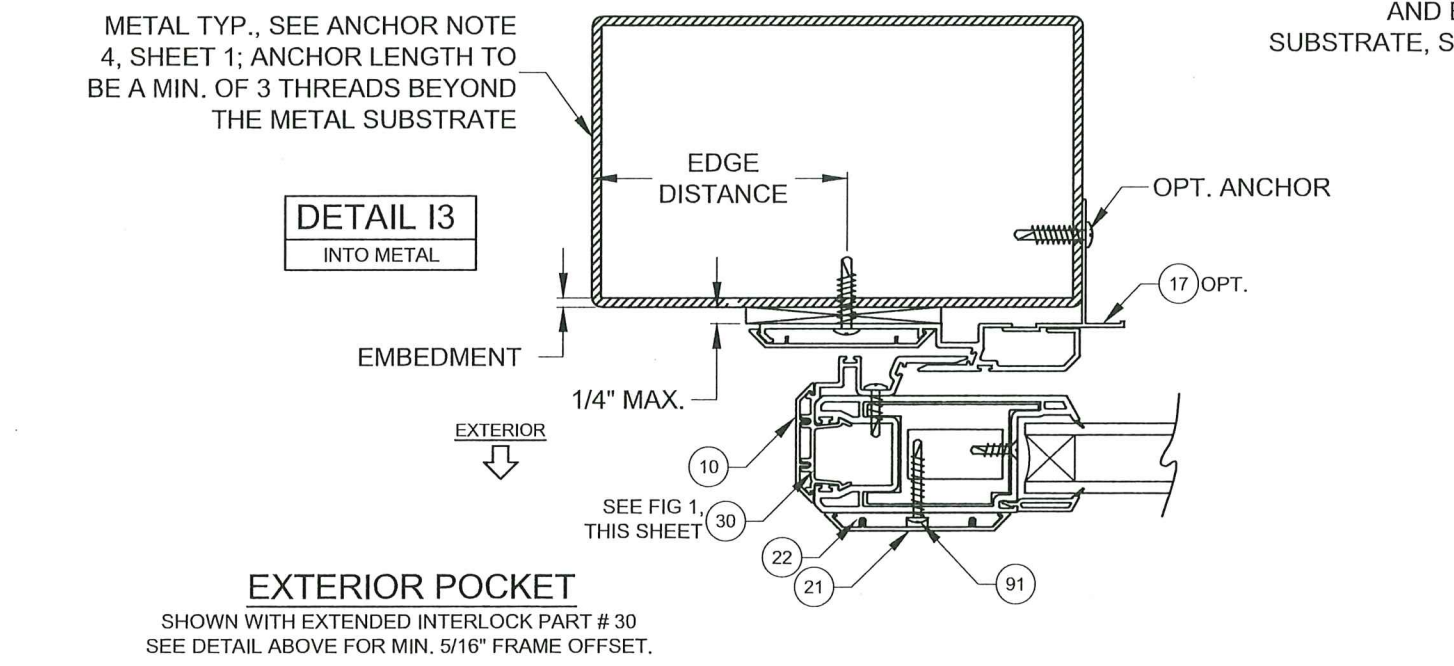
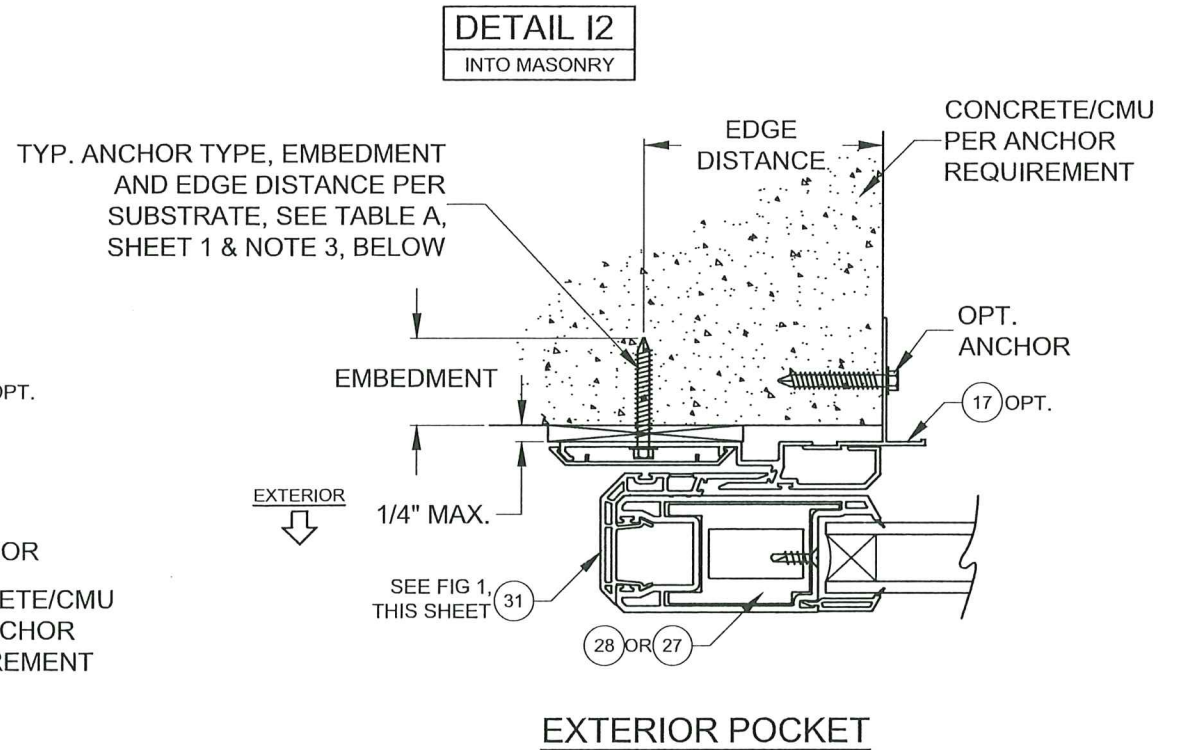
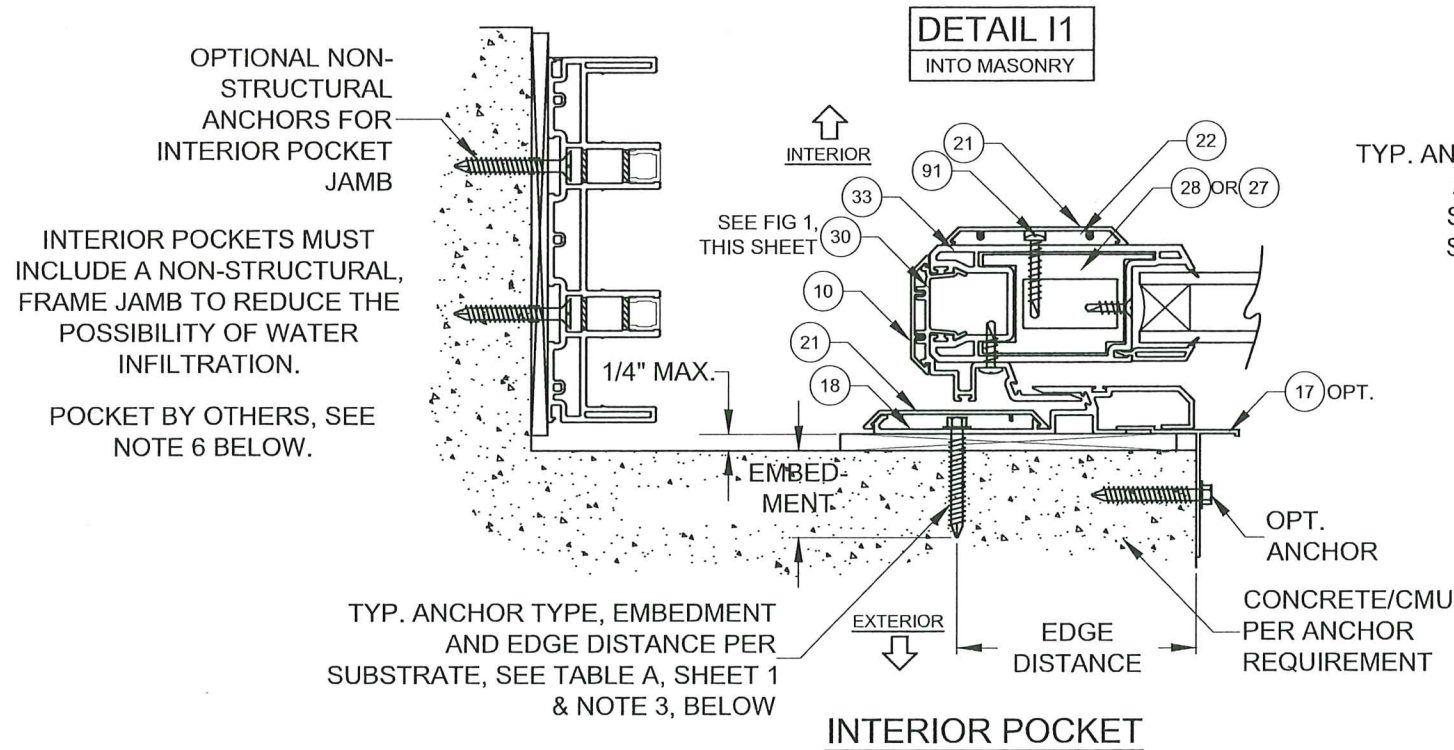

- NOTES**
- 1) DETAILS APPLY TO 2, 3 AND 4 TRACK CONFIGURATIONS.
  - 2) REFER TO ANCHOR NOTES, SHEET 1.
  - 3) SEE SHEET 13 FOR ANCHOR LOCATION & SPACING, FOR ANCHOR QUANTITIES, SEE TABLES 1 & 2.
  - 4) SEE TABLES 1 & 2 FOR REINFORCEMENT REQUIREMENTS.
  - 5) INTERIOR OR EXTERIOR POCKETS APPLICABLE FOR ALL INSTALLATION METHODS.
  - 6) POCKET WALL OR CAVITY IS NOT PART OF THIS APPROVAL AND IS TO BE DESIGNED BY OTHERS AND REVIEWED BY THE AUTHORITY HAVING JURISDICTION.

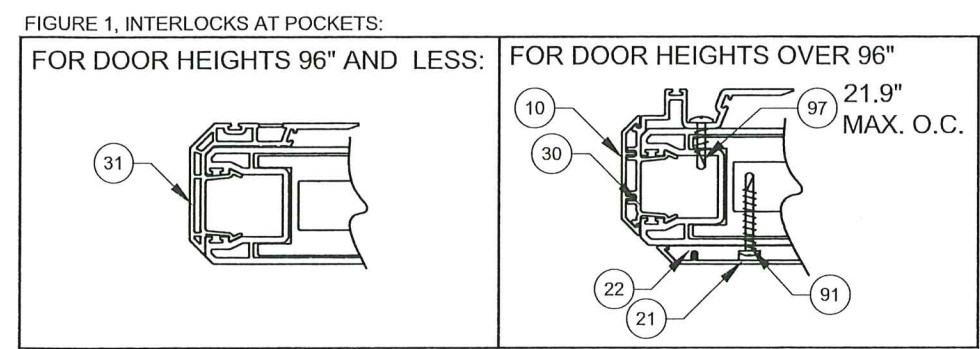

**PRODUCT REVISED**  
 as complying with the Florida  
 Building Code  
 Acceptance No. 26-0126.02  
 Expiration Date 4/21/2031  
 By A. Lynn Miller  
 Miami Dade Product Control

PREPARED BY A. LYNN MILLER 1070 TECHNOLOGY DRIVE N. VENICE, FL 34275 (941) 480-1600 REGISTRATION #29296	Date	10/05/15	Rev.	E
	Drawn By	JENS ROSOWSKI	DWG No.	MD-5470.0
<b>PGT</b> Custom Windows and Doors 3400 PRECISION DRIVE N. VENICE, FL 34275 (941) 480-1600	VINYL SLIDING GLASS DOOR (NI) POCKET HORIZ. X-SECTION	Sheet 6 OF 21	Series SGD-5470	

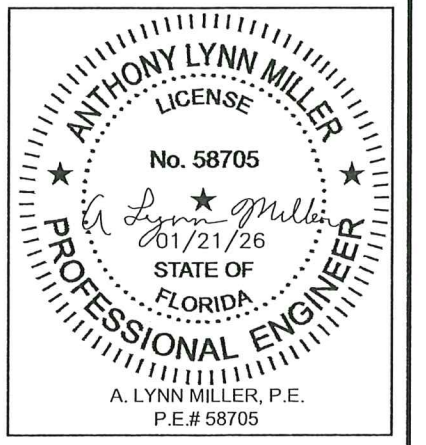

TABLE 1:

Design Pressure (DP) and Anchor Quantities Required, (for all approved configurations on Sheet 2)														
Use this table for:			Door Unit Height											
			80"				84"				96"			
Astragal Reinforcement #29			68-15/16" DLO Height				72-15/16" DLO Height				84-15/16" DLO Height			
Lockstile Reinforcement #25 or #26			Anchor Group				Anchor Group				Anchor Group			
Std. Interlock Reinforcement #27			A	B	C	D	A	B	C	D	A	B	C	D
Nominal Panel Width	24"	16-5/8" DLO Width	Design Pressure +127.1 / -127.1 psf				+120 / -120 psf				+102.9 / -102.9 psf			
		Head/Sill	C5+1	C3+1	C3+1	C3+1	C5+1	C3+1	C3+1	C3+1	C5+1	C3+1	C3+1	C3+1
		Jamb	5	5	6	5	5	5	6	5	5	5	6	5
	P-hook	7	7	7	7	7	7	7	7	8	8	8	8	
	30"	22-5/8" DLO Width	Design Pressure +106.3 / -106.3 psf				+100.2 / -100.2 psf				+85.3 / -85.3 psf			
		Head/Sill	C5+1	C3+1	C3+1	C3+1	C5+1	C3+1	C3+1	C3+1	C5+1	C3+1	C3+1	C3+1
		Jamb	5	5	6	5	5	5	6	5	5	5	6	5
	P-hook	7	7	7	7	7	7	7	7	8	8	8	8	
	36"	28-5/8" DLO Width	Design Pressure +92.9 / -92.9 psf				+87.3 / -87.3 psf				+73.8 / -73.8 psf			
		Head/Sill	C5+1	C3+1	C3+1	C3+1	C5+1	C3+1	C3+1	C3+1	C5+1	C3+1	C3+1	C3+1
		Jamb	5	5	6	5	5	5	6	5	5	5	6	5
	P-hook	7	7	7	7	7	7	7	7	8	8	8	8	
	42"	34-5/8" DLO Width	Design Pressure +78.4 / -78.4 psf				+78.4 / -78.4 psf				+65.8 / -65.8 psf			
		Head/Sill	C5+2	C3+1	C3+1	C3+1	C5+2	C3+1	C3+1	C3+1	C5+1	C3+1	C3+1	C3+1
		Jamb	5	5	5	5	5	5	6	5	5	5	6	5
P-hook	7	7	7	7	7	7	7	7	8	8	8	8		
48"	40-5/8" DLO Width	Design Pressure +60 / -60 psf				+60 / -60 psf				+60 / -60 psf				
	Head/Sill	C3+2	C3+1	C3+1	C3+1	C3+2	C3+1	C3+1	C3+1	C5+2	C3+1	C3+1	C3+1	
	Jamb	5	5	5	5	5	5	5	5	5	5	6	5	
P-hook	7	7	7	7	7	7	7	7	8	8	8	8		

USED IN EXAMPLE ON SHEET 9

ANCHORAGE TYPE PER SUBSTRATE REQUIRED TO ACHIEVE THE DESIGN PRESSURE, USING THE ANCHOR QUANTITIES LISTED BELOW. SEE TABLE A, SHEET 1 FOR COMPLETE ANCHOR LIMITATIONS.

THE MAXIMUM DP AT THESE ANCHOR QUANTITIES. ADDITIONALLY, THE MAXIMUM POSITIVE DP DUE TO THE SILL HEIGHT MUST ALSO BE CONSIDERED, SEE TABLE B1, THIS SHEET.

# OF ANCHORS THROUGH THE HEAD & SILL. (EX: FOR C3+1, 3 ANCHORS CLUSTERED AT PANEL MEETING POINT AND 1 ANCHOR REQUIRED AT MIDSPAN OF PANEL).

TOTAL # OF ANCHORS THROUGH THE JAMB.

THE # OF ANCHORS REQUIRED THROUGH THE P-HOOK, PERPENDICULAR TO THE GLASS.

TABLE B1:

Water-Limited (+) Design Pressure		
Sill Riser	Nom. Sill Height	Max. (+) DP Allowed
None	1-11/16"	See Note 2
42	2-1/2"	+38.7 psf
43	3-1/2"	+60.0 psf
44	4-1/16"	+80.0 psf
45	4-5/8"	+100.0 psf

FIG 1:

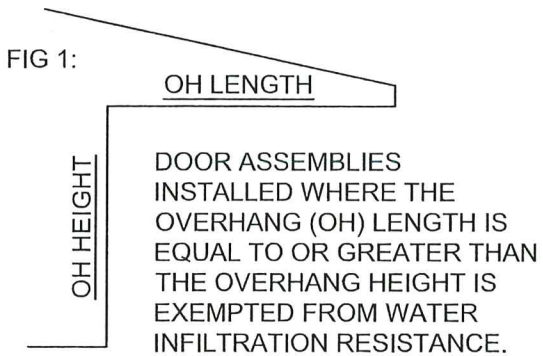

TABLE NOTES:

- 1) IF WATER INFILTRATION RESISTANCE IS REQUIRED, THE LESSER VALUES OF EITHER TABLE 1 AND TABLE B1 DETERMINES THE WATER LIMITED (+) DP.
- 2) IF WATER INFILTRATION RESISTANCE IS NOT REQUIRED OR OVERHANG IS PER FIG 1, A SILL RISER IS NOT REQUIRED. IF SO, +DP'S SHOWN IN TABLE 1 MAY BE USED.
- 3) SEE SILL RISER TYPES ON SHEET 4.
- 4) SHEET APPLIES TO 2, 3 AND 4 TRACK CONFIGURATIONS.
- 5) REFER TO ANCHOR NOTES, SHEET 1.
- 6) SEE SHEETS 11-16 FOR ANCHOR LOCATION & SPACING

DLO WIDTH = NOM. PANEL WIDTH - 7-3/8"  
DLO HEIGHT = DOOR HEIGHT - 11-1/16"  
PANEL HEIGHT = DOOR HEIGHT - 2-1/2"

PRODUCT REVISED  
as complying with the Florida Building Code  
Acceptance No. 26-0126.02  
Expiration Date 4/21/2031  
By [Signature]  
Miami Dade Product Control

Revision:

PREPARED BY A. LYNN MILLER 1070 TECHNOLOGY DRIVE N. VENICE, FL 34275	REGISTRATION #29296	Date	10/05/15
		Drawn By	JENS ROSOWSKI
PGI Custom Windows and Doors 3400 PRECISION DRIVE N. VENICE, FL 34275 (941) 480-1600	VINYL SLIDING GLASS DOOR (NI)	No.	7 OF 21
		DWG	MD-5470.0
DP & ANCHOR QUANTITY TABLE		Series	SGD-5470

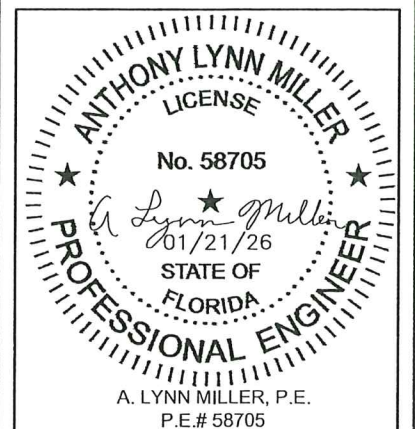

TABLE 2:

**Design Pressure (DP) and Anchor Quantities Required,**  
(for all approved configurations on Sheet 2)

Use this table for: Astragal Reinforcement #29 Lockstile Reinforcement #25 HD Interlock Reinforcement #28			Door Unit Height																				
			80"				84"				96"				108"				120"				
			68-15/16" DLO Height				72-15/16" DLO Height				84-15/16" DLO Height				96-15/16" DLO Height				108-15/16" DLO Height				
			Anchor Group				Anchor Group				Anchor Group				Anchor Group				Anchor Group				
			A	B	C	D	A	B	C	D	A	B	C	D	A	B	C	D	A	B	C	D	
Nominal Panel Width	24"	16-5/8" DLO Width	Design Pressure	+169.4 / -169.4 psf				+160 / -160 psf				+137.1 / -137.1 psf				+120 / -130 psf				+106.7 / -115.6 psf			
		Head/Sill	C5+1	C5+1	C5+1	C3+1	C5+1	C5+1	C5+1	C3+1	C5+1	C5+1	C5+1	C3+1	C5+1	C5+1	C5+1	C3+1	C5+1	C5+1	C5+1	C3+1	
		Jamb	5	5	7	5	5	5	7	5	5	5	7	5	6	6	8	6	6	6	8	6	
		P-hook	7	7	7	7	7	7	7	7	8	8	8	8	9	9	9	9	10	10	10	10	
	30"	22-5/8" DLO Width	Design Pressure	+141.8 / -141.8 psf				+133.6 / -133.6 psf				+113.8 / -113.8 psf				+99.1 / -107.4 psf				+87.8 / -95.1 psf			
		Head/Sill	C5+2	C5+1	C5+1	C3+1	C5+1	C5+1	C5+1	C3+1	C5+1	C5+1	C5+1	C3+1	C5+1	C5+1	C5+1	C3+1	C5+1	C5+1	C5+1	C3+1	
		Jamb	5	5	7	5	5	5	7	5	5	5	7	5	6	6	8	6	6	6	8	6	
		P-hook	7	7	7	7	7	7	7	7	8	8	8	8	9	9	9	9	10	10	10	10	
	36"	28-5/8" DLO Width	Design Pressure	+123.9 / -123.9 psf				+116.4 / -116.4 psf				+98.5 / -98.5 psf				+85.3 / -92.4 psf				+75.3 / -81.6 psf			
		Head/Sill	C5+2	C5+1	C5+2	C3+1	C5+2	C5+1	C5+2	C3+1	C5+2	C5+1	C5+1	C3+1	C5+1	C5+1	C5+1	C3+1	C5+1	C5+1	C5+1	C3+1	
		Jamb	5	5	7	5	5	5	7	5	5	5	7	5	6	6	8	6	6	6	8	6	
		P-hook	7	7	7	7	7	7	7	7	8	8	8	8	9	9	9	9	10	10	10	10	
	42"	34-5/8" DLO Width	Design Pressure	+104.5 / -104.5 psf				+104.5 / -104.5 psf				+87.8 / -87.8 psf				+75.7 / -82 psf				+66.5 / -72 psf			
		Head/Sill	C5+2	C3+2	C5+2	C3+1	C5+2	C5+2	C5+2	C3+1	C5+2	C5+1	C5+2	C3+1	C5+2	C5+1	C5+2	C3+1	C5+1	C5+1	C5+1	C3+1	
		Jamb	5	5	7	5	5	5	7	5	5	5	7	5	6	6	8	6	6	6	8	6	
		P-hook	7	7	7	7	7	7	7	7	8	8	8	8	9	9	9	9	10	10	10	10	
	48"	40-5/8" DLO Width	Design Pressure	+80 / -80 psf				+80 / -80 psf				+80 / -80 psf				+60 / -65 psf				+60 / -65 psf			
		Head/Sill	C5+2	C3+2	C5+2	C3+1	C5+2	C3+2	C5+2	C3+1	C5+2	C5+2	C5+2	C3+1	C5+2	C3+1	C5+2	C3+1	C5+2	C5+1	C5+2	C3+1	
Jamb		5	5	6	5	5	5	6	5	5	5	7	5	6	6	7	6	6	6	8	6		
	P-hook	7	7	7	7	7	7	7	7	8	8	8	8	9	9	9	9	10	10	10	10		
54"	46-5/8" DLO Width	Design Pressure	+74.1 / -74.1 psf				+74.1 / -74.1 psf				+63.8 / -63.8 psf				Not available in these sizes.								
	Head/Sill	C5+2	C3+2	C3+2	C3+1	C5+2	C3+2	C5+2	C3+1	C5+2	C3+2	C5+2	C3+1										
	Jamb	5	5	6	5	5	5	6	5	5	5	6	5										
	P-hook	7	7	7	7	7	7	7	7	8	8	8	8										
60"	52-5/8" DLO Width	Design Pressure	+60 / -60 psf				+60 / -60 psf				+60 / -60 psf												
	Head/Sill	C3+2	C3+2	C3+2	C3+1	C5+2	C3+2	C3+2	C3+1	C5+2	C3+2	C5+2	C3+1										
	Jamb	5	5	5	5	5	5	5	5	5	5	6	5										
	P-hook	7	7	7	7	7	7	7	7	8	8	8	8										

ANCHORAGE TYPE PER SUBSTRATE REQUIRED TO ACHIEVE THE DESIGN PRESSURE, USING THE ANCHOR QUANTITIES LISTED BELOW. SEE TABLE A, SHEET 1 FOR COMPLETE ANCHOR LIMITATIONS.

THE MAXIMUM DP AT THESE ANCHOR QUANTITIES. ADDITIONALLY, THE MAXIMUM POSITIVE DP DUE TO THE SILL HEIGHT MUST ALSO BE CONSIDERED, SEE TABLE B2, THIS SHEET.

# OF ANCHORS THROUGH THE HEAD & SILL. (EX: FOR C3+1, 3 ANCHORS CLUSTERED AT PANEL MEETING POINT AND 1 ANCHOR REQUIRED AT MIDSPAN OF PANEL).

TOTAL # OF ANCHORS THROUGH THE JAMB. THE # OF ANCHORS REQUIRED THROUGH THE P-HOOK, PERPENDICULAR TO THE GLASS.

FIG 1:

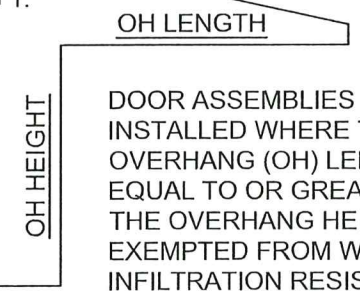

DOOR ASSEMBLIES INSTALLED WHERE THE OVERHANG (OH) LENGTH IS EQUAL TO OR GREATER THAN THE OVERHANG HEIGHT IS EXEMPTED FROM WATER INFILTRATION RESISTANCE.

TABLE B2:

Water-Limited (+) Design Pressure		
Sill Riser	Nom. Sill Height	Max. (+) DP Allowed
None	1-11/16"	See Note 2
42	2-1/2"	+38.7 psf
43	3-1/2"	+60.0 psf
44	4-1/16"	+80.0 psf
45	4-5/8"	+100.0 psf

DLO WIDTH = NOM. PANEL WIDTH - 7-3/8"  
DLO HEIGHT = DOOR HEIGHT - 11-1/16"  
PANEL HEIGHT = DOOR HEIGHT - 2-1/2"

TABLE NOTES:

- IF WATER INFILTRATION RESISTANCE IS REQUIRED, THE LESSER VALUES OF EITHER TABLE 2 AND TABLE B2 DETERMINES THE WATER LIMITED (+) DP.
- IF WATER INFILTRATION RESISTANCE IS NOT REQUIRED OR OVERHANG IS PER FIG 1, A SILL RISER IS NOT REQUIRED. IF SO, +DP'S SHOWN IN TABLE 2 MAY BE USED.
- SEE SILL RISER TYPES ON SHEET 4.
- SHEET APPLIES TO 2, 3 AND 4 TRACK CONFIGURATIONS.
- REFER TO ANCHOR NOTES, SHEET 1.
- SEE SHEETS 11-16 FOR ANCHOR LOCATION & SPACING

PRODUCT REVISED as complying with the Florida Building Code  
Acceptance No 26-0126-02  
Expiration Date 4/21/2031  
By L. Lynn Miller  
Miami Dade Product Control

Revision:

PREPARED BY A. LYNN MILLER 1070 TECHNOLOGY DRIVE N. VENICE, FL 34275 (941) 480-1600 REGISTRATION #29296	Date	10/05/15	Rev.	E
	Drawn By	JENS ROSOWSKI	DWG No.	MD-5470.0
	VINYL SLIDING GLASS DOOR (NI)		Sheet	8 OF 21
PGT Custom Windows and Doors 3400 PRECISION DRIVE N. VENICE, FL 34275 (941) 480-1600		DP & ANCHOR QUANTITY TABLE SGD-5470		

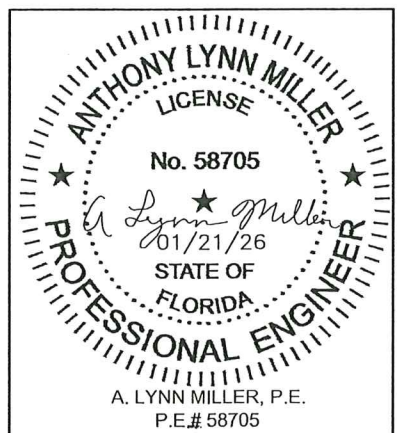

**EXAMPLE:**  
 3-PANEL, 3 TRACK, STRAIGHT  
 CONFIGURATION - PXXX,  
 INTERIOR MOUNT POCKET, 48" X 84"  
 NOM. PANELS,  
 LAMINATED, IG GLAZING, ANCHOR  
 GROUP A IN WOOD SUBSTRATE,  
 PROJECT DESIGN PRESSURE  
 REQUIRED: +48.2/-58.6 PSF

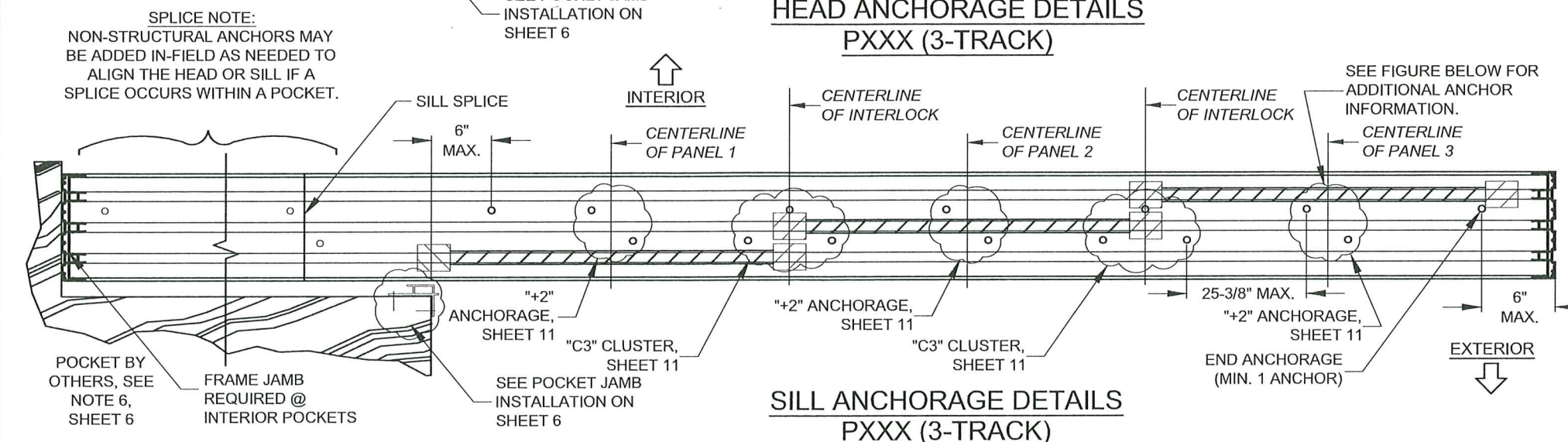
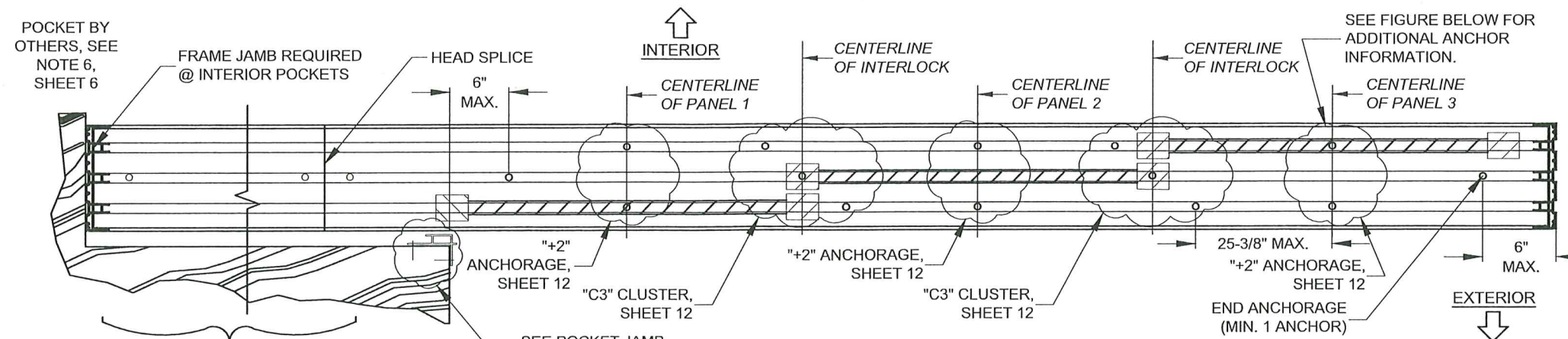
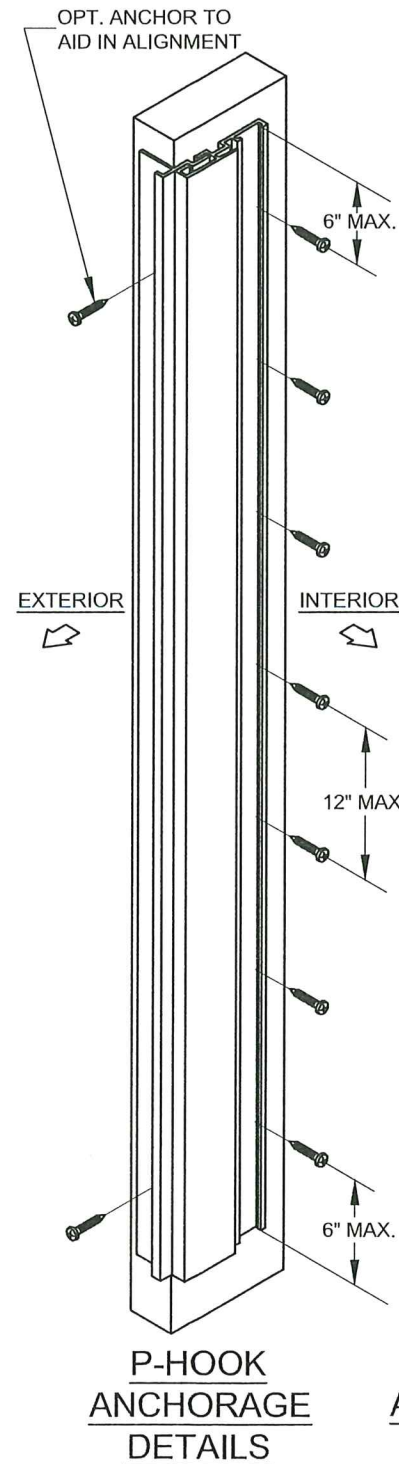

**SPLICE NOTE:**  
 NON-STRUCTURAL ANCHORS MAY  
 BE ADDED IN-FIELD AS NEEDED TO  
 ALIGN THE HEAD OR SILL IF A  
 SPLICE OCCURS WITHIN A POCKET.

1) KNOWING THE PRODUCT'S REQUIREMENTS, SCAN THROUGH TABLES 1 & 2 FOR A DESIGN PRESSURE THAT MEETS OR EXCEEDS THE REQUIREMENT OF +48.2/-58.6 AT A NOM. PANEL SIZE OF 48" X 84". FROM TABLE 1, SHEET 7, THE DESIGN PRESSURE IS +60/-60 WHICH EXCEEDS THE PROJECT DESIGN PRESSURE REQUIREMENTS.

FOR WOOD INSTALLATION USING ANY ANCHOR IN GROUP A (SEE TABLE A), TABLE 1 SHOWS ANCHOR REQUIREMENTS OF:

Head/Sill	C3+2
Jamb	5
P-hook	7

2) ANCHOR LOCATION DETAILS, CAN BE FOUND ON:  
**HEAD (CLUSTER ANCHORS):** SHEET 12 FOR THE "C3" CLUSTER ANCHORS AT THE INTERLOCK/ASTRAGAL.  
**HEAD (INTERMEDIATE ANCHORS):** SHEET 12 FOR THE "+2" ANCHORS AT THE MIDSPAN OF EACH PANEL.  
**SILL (CLUSTER ANCHORS):** SHEET 11 FOR THE "C3" CLUSTER ANCHORS AT THE INTERLOCK/ASTRAGAL.  
**SILL (INTERMEDIATE ANCHORS):** SHEET 11 FOR THE "+2" ANCHORS AT THE MIDSPAN OF EACH PANEL.  
**JAMB:** 5 ANCHORS, SHEET 13 FOR GEN. LAYOUT.  
**P-HOOK:** 7 ANCHORS, SHEET 13 FOR GENERAL LAYOUT.

3) INSTALLATION DETAILS INTO WOOD CAN BE FOUND ON:  
**HEAD & SILL:** SHEET 4  
**JAMB:** SHEET 3  
**P-HOOK:** SHEET 6

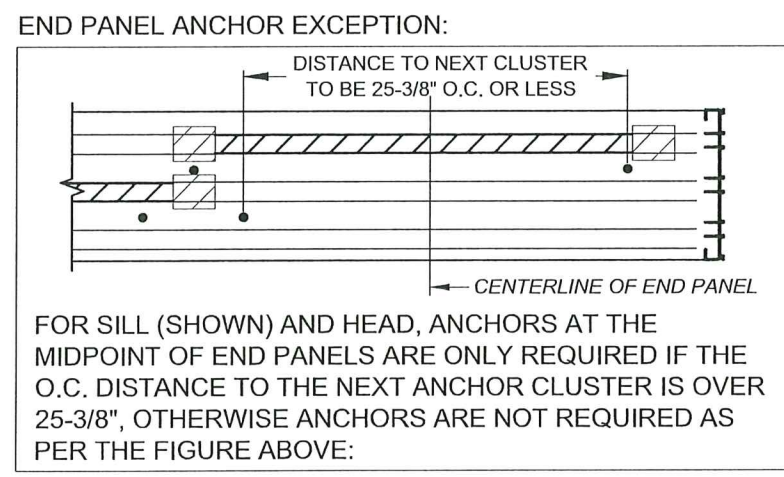

FOR SILL (SHOWN) AND HEAD, ANCHORS AT THE MIDPOINT OF END PANELS ARE ONLY REQUIRED IF THE O.C. DISTANCE TO THE NEXT ANCHOR CLUSTER IS OVER 25-3/8", OTHERWISE ANCHORS ARE NOT REQUIRED AS PER THE FIGURE ABOVE:

FOR PRODUCT REFERENCES, ALSO SEE:  
 A) SHEET 2 FOR ALLOWABLE CONFIGURATIONS AND EXACT LOCATIONS OF CROSS-SECTION DRAWINGS.  
 B) SHEET 10 FOR SPECIFIC GLAZING TYPES.  
 C) SHEET 17 FOR ALLOWABLE PANEL TYPES AND CALL NAMES.  
 D) SHEETS 4 & 18 FOR EXTRUSION CROSS-SECTION DRAWINGS.  
 E) SHEET 19 FOR INSTALLATION OF ADDITIONAL ACCESSORIES.  
 F) SHEET 21 FOR A BILL OF MATERIALS.

**PRODUCT REVISED**  
 as complying with the Florida  
 Building Code  
 Acceptance No 26-0126.02  
 Expiration Date 4/21/2031  
 By Ishang L. Ullah  
 Miami Dade Product Control

PREPARED BY A. LYNN MILLER 1070 TECHNOLOGY DRIVE N. VENICE, FL 34275 (941) 480-1600 REGISTRATION #29296	Date	10/05/15	Drawn By <b>JENS ROSOWSKI</b>	Dwg. No. MD-5470.0	Rev. E
	VINYL SLIDING GLASS DOOR (NI)				
<b>PGT</b> Custom Windows and Doors 3400 PRECISION DRIVE N. VENICE, FL 34275 (941) 480-1600	Series Desc. Title <b>EXAMPLE</b>		Sheet 9 OF 21	No.	Rev.
	REGISTRATION #29296				

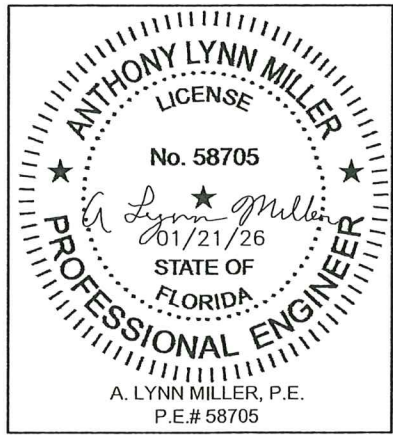

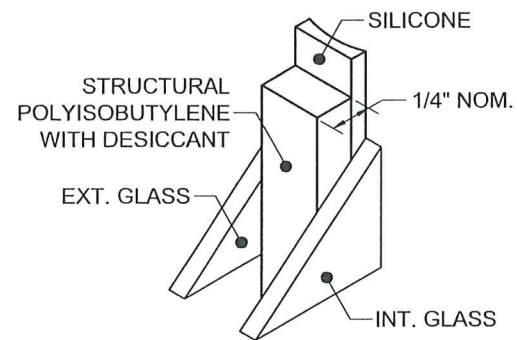

75 **KODISPACE**  
**4SG TPS**

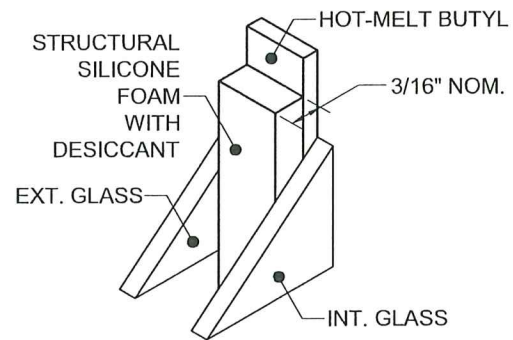

76 **SUPER SPACER**<sup>®</sup> **NXT**<sup>™</sup>

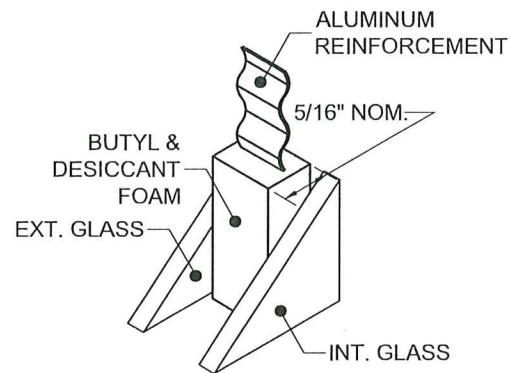

77 **DURASEAL**<sup>®</sup>  
**SPACER**

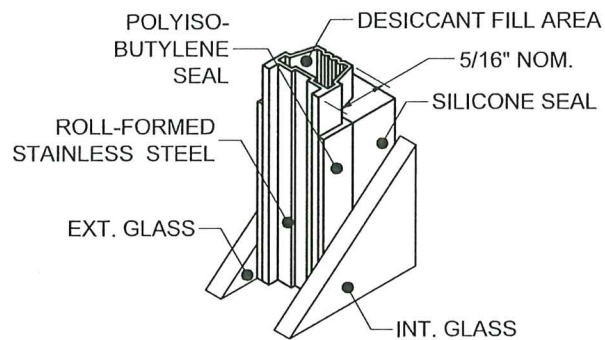

78 **XL EDGE**<sup>™</sup>  
**SPACER**

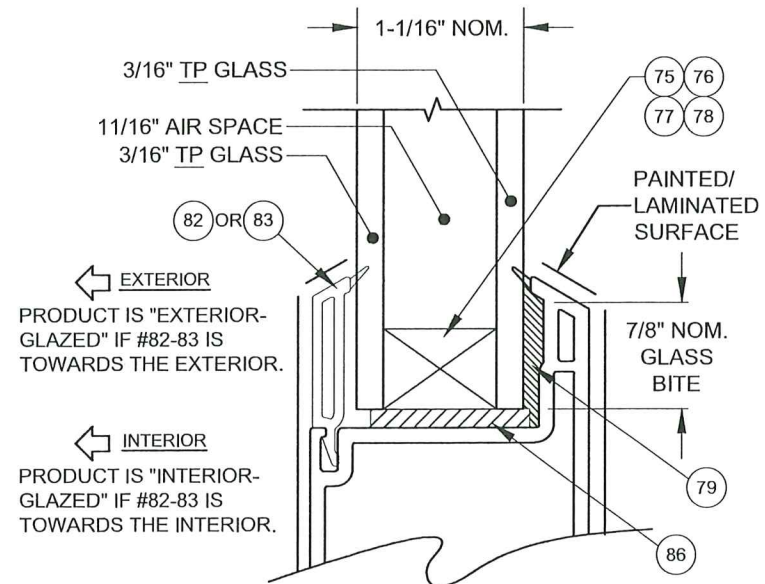

**GLASS DETAIL**

**NOTES:**

- 1) BACKBEDDING SURFACES SHALL NOT BE PAINTED OR LAMINATED.
- 2) PRODUCT MAY BE EITHER INTERIOR OR EXTERIOR GLAZED.

"TP" = TEMPERED

PRODUCT REVISED  
as complying with the Florida  
Building Code  
Acceptance No. 26-0126.02  
Expiration Date 4/21/2031  
By Ishag J. Miller  
Miami Dade Product Control

Revision:

PREPARED BY A. LYNN MILLER 1070 TECHNOLOGY DRIVE N. VENICE, FL 34275 (941) 480-1600	REGISTRATION #29296 (941) 480-1600	Date	10/05/15	Rev.	E
		By	JENS ROSOWSKI	DWG No.	MD-5470.0
<b>PGT</b> Custom Windows and Doors 3400 PRECISION DRIVE N. VENICE, FL 34275 (941) 480-1600		VINYL SLIDING GLASS DOOR (NI) GLAZING DETAILS		Sheet	10 OF 21
		Series Desc.	SGD-5470		

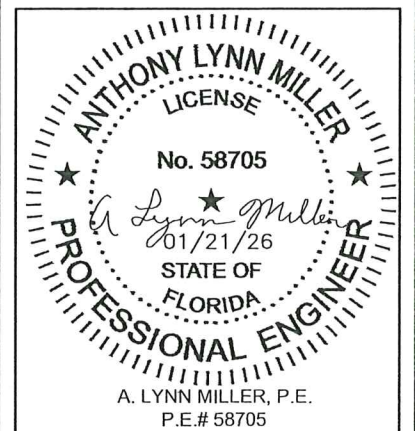

**SILL CLUSTER ANCHORS LAYOUT:**

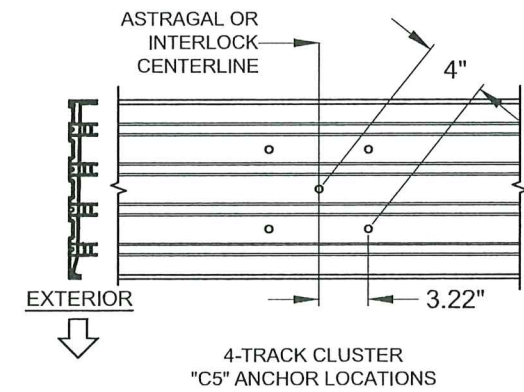
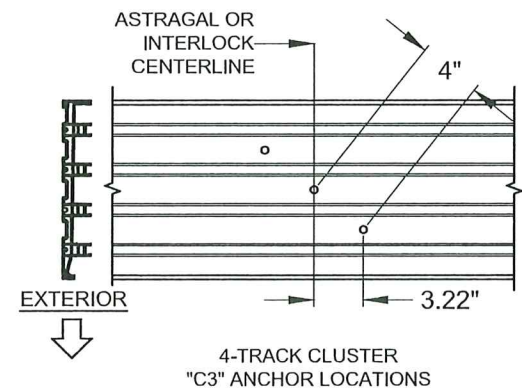
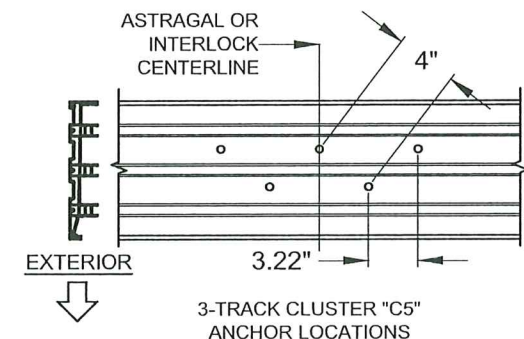
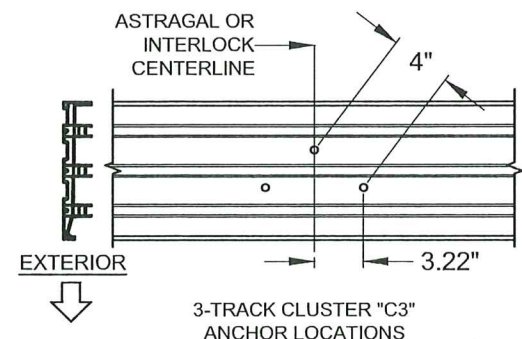
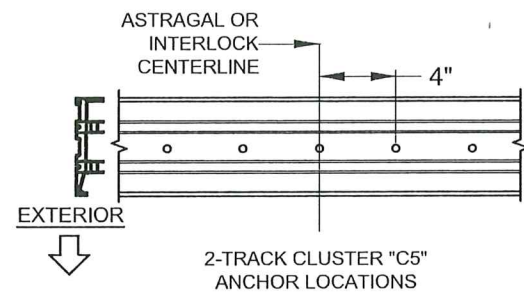
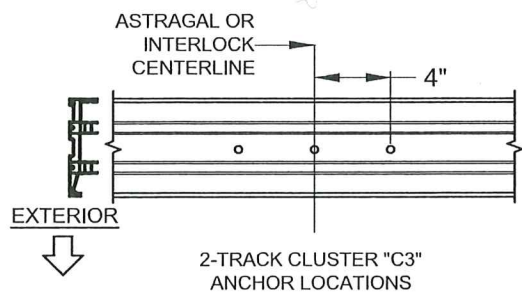

**SILL "+" INTERMEDIATE ANCHORS LAYOUT:**

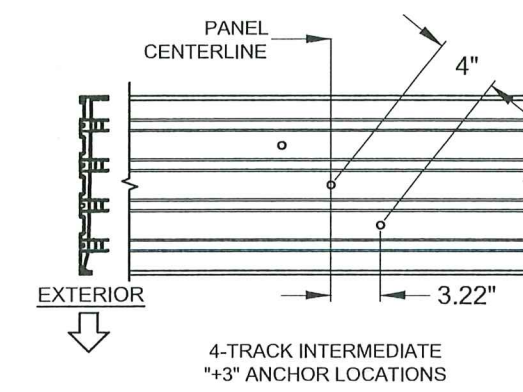
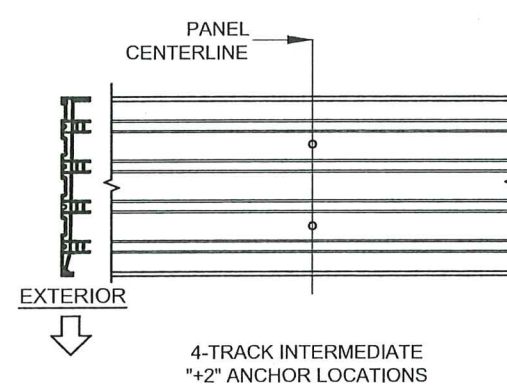
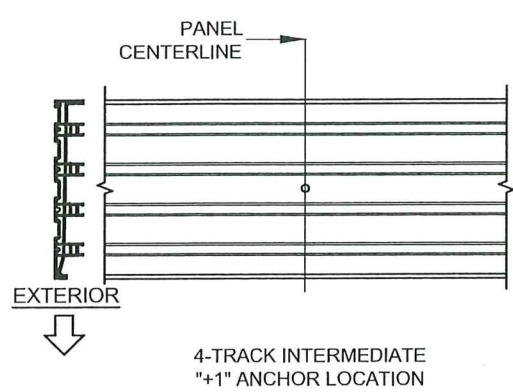
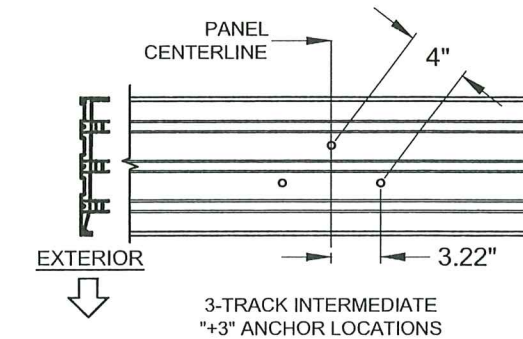
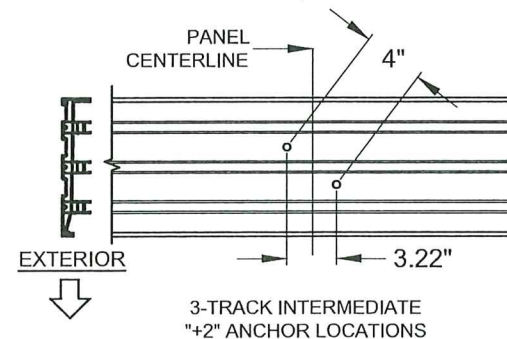
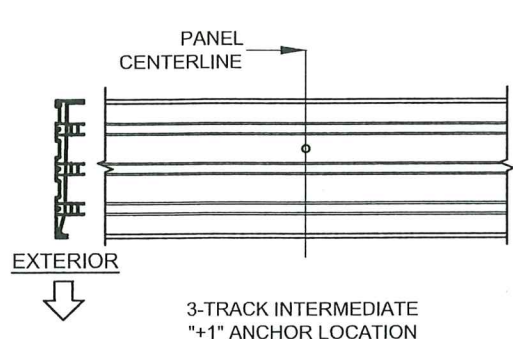
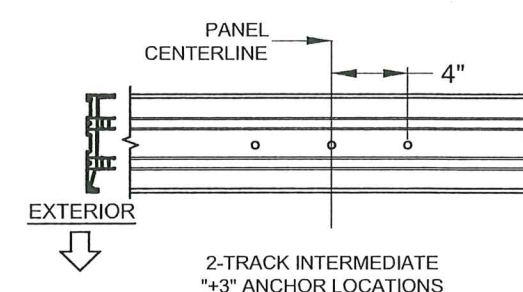
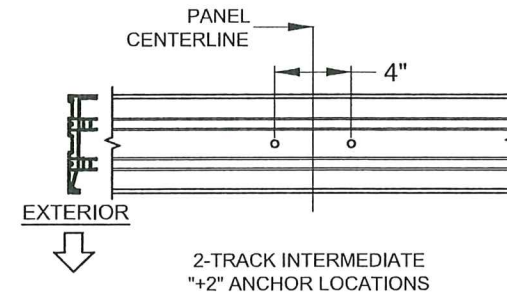
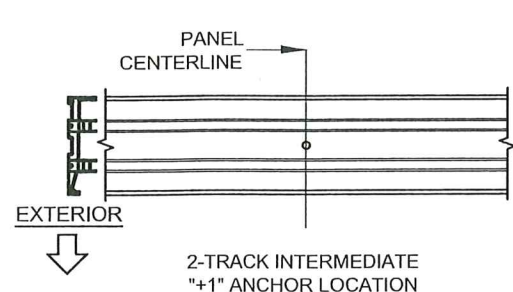

FIGURES PERTAIN TO THE FOLLOWING SILL INTERMEDIATE ANCHOR LOCATIONS:

Head/Sill	C3+1
Jamb	5
P-hook	7

**NOTES:**  
1) ALL DIMENSIONS SHOWN ARE BASED ON MINIMUM ALLOWED.

2) TRACK-TO-TRACK DISTANCE IS 2.375" FOR ALL SILLS:

**NOTES:**  
1) ALL DIMENSIONS SHOWN ARE BASED ON MINIMUM ALLOWED.

2) TRACK-TO-TRACK DISTANCE IS 2.375" FOR ALL SILLS:

FIGURES PERTAIN TO THE FOLLOWING SILL CLUSTER ANCHOR LOCATIONS:

Head/Sill	C3+1
Jamb	5
P-hook	7

**PRODUCT REVISED**  
as complying with the Florida Building Code  
Acceptance No. 26-0126-02  
Expiration Date 4/24/2031  
By: [Signature]  
Miami Dade Product Control

**PGT**  
Custom Windows and Doors  
3400 PRECISION DRIVE  
N. VENICE, FL 34275  
(941) 480-1600

PREPARED BY A. LYNN MILLER  
1070 TECHNOLOGY DRIVE  
N. VENICE, FL 34275  
(941) 480-1600  
REGISTRATION #29296

Series	SGD-5470	Sheet	11 OF 21	DWG No.	MD-5470.0	Rev.	E
--------	----------	-------	----------	---------	-----------	------	---

Title	VINYL SLIDING GLASS DOOR (NI)	Date	10/05/15
Desc.	ANCHOR LAYOUTS	Drawn By	JENS ROSOWSKI
Rev		Rev Date	01/15/26

**ANTHONY LYNN MILLER**  
LICENSE  
No. 58705  
01/21/26  
STATE OF FLORIDA  
**PROFESSIONAL ENGINEER**  
A. LYNN MILLER, P.E.  
P.E.# 58705

### HEAD CLUSTER ANCHORS LAYOUT:

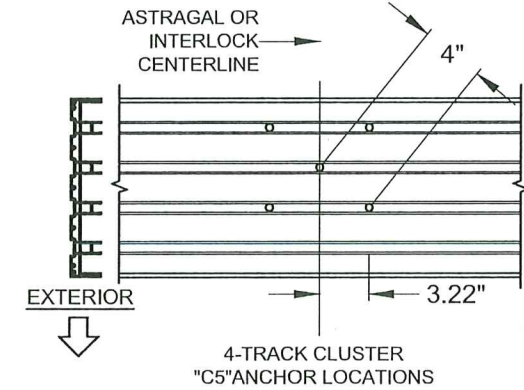
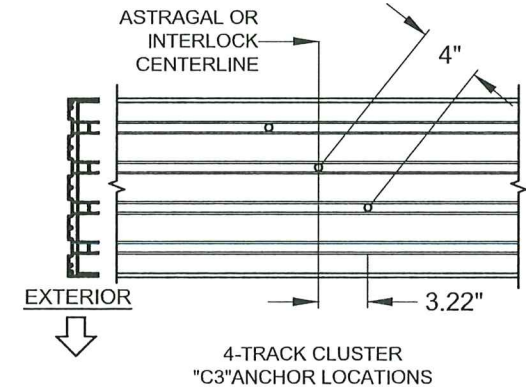
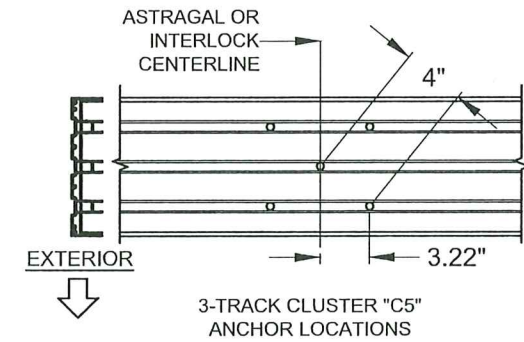
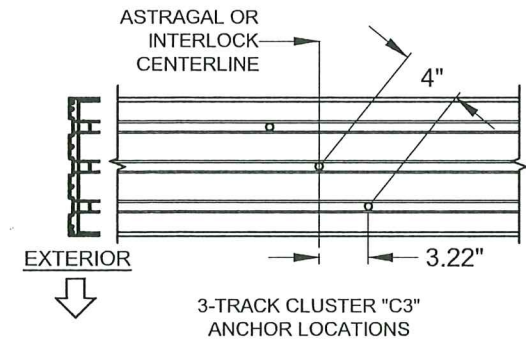
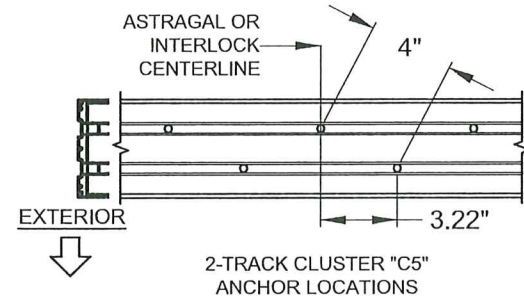
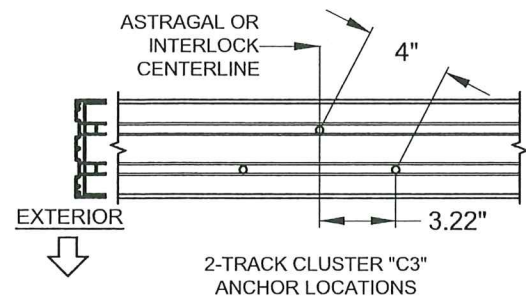

### HEAD "+" INTERMEDIATE ANCHORS LAYOUT:

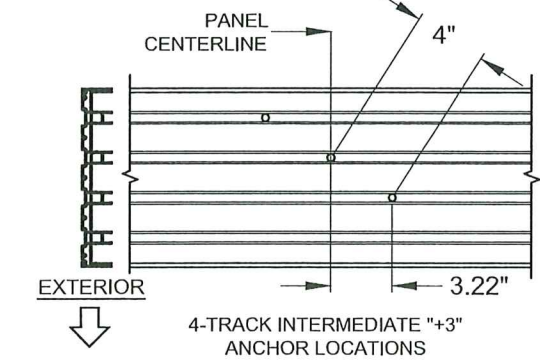
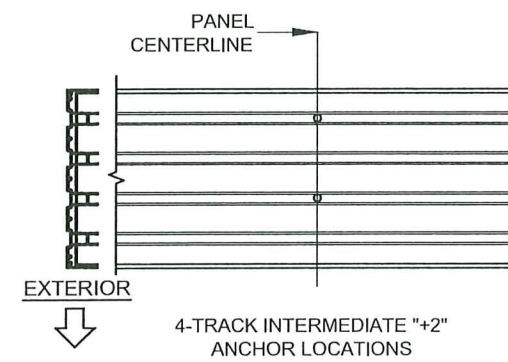
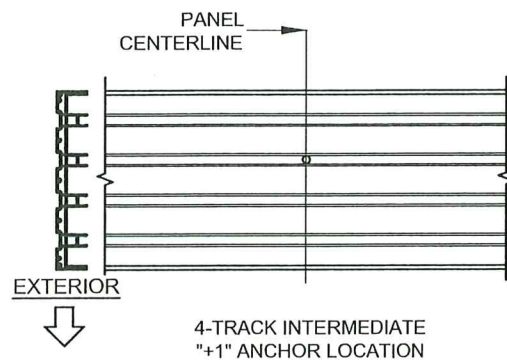
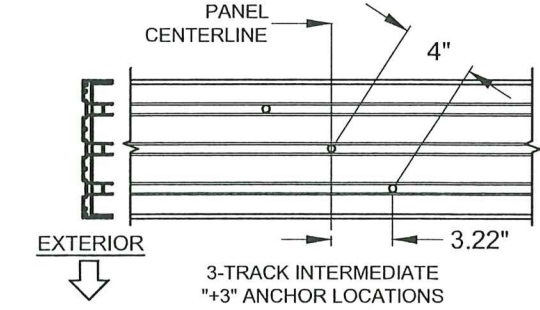
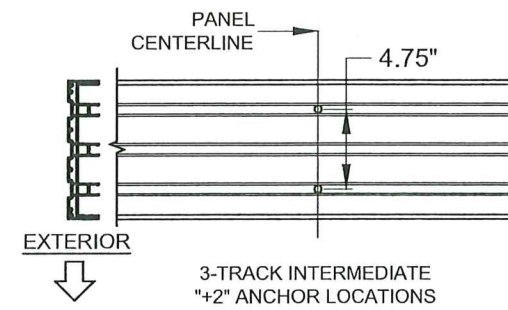
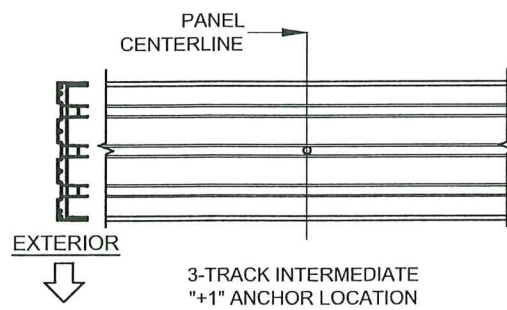
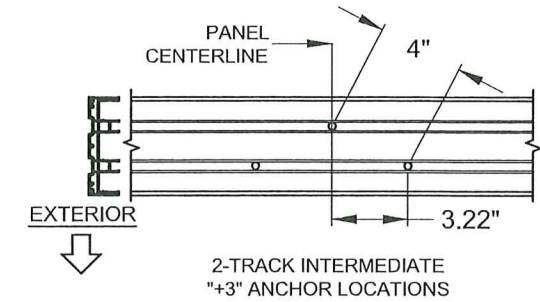
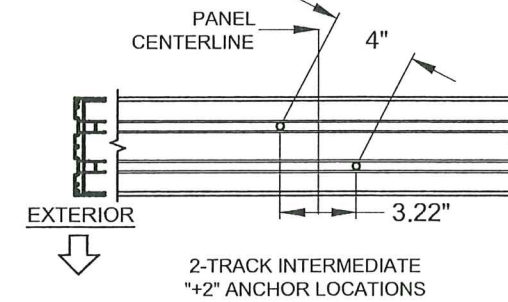
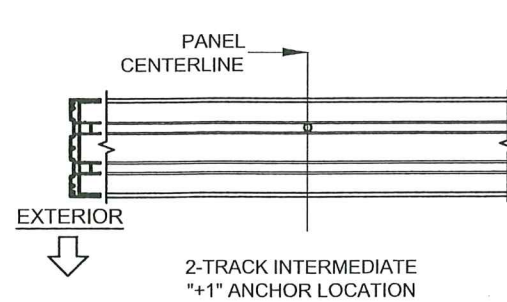

**NOTES:**

1) ALL DIMENSIONS SHOWN ARE BASED ON MINIMUM ALLOWED.

2) TRACK-TO-TRACK DISTANCE IS 2.375" FOR ALL HEADS:

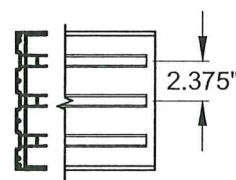

FIGURES PERTAIN TO THE FOLLOWING HEAD INTERMEDIATE ANCHOR LOCATIONS:

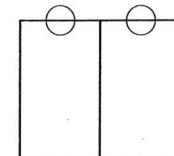
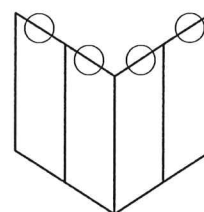

Head/Sill	C3+1
Jamb	5
P-hook	7

**NOTES:**

1) ALL DIMENSIONS SHOWN ARE BASED ON MINIMUM ALLOWED.

2) TRACK-TO-TRACK DISTANCE IS 2.375" FOR ALL SILLS:

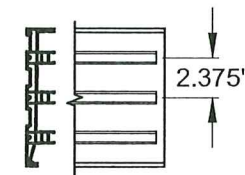

FIGURES PERTAIN TO THE FOLLOWING HEAD CLUSTER ANCHOR LOCATIONS:

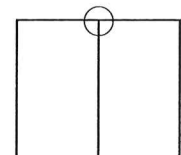
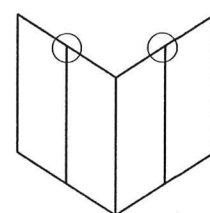

Head/Sill	C3+1
Jamb	5
P-hook	7

PRODUCT REVISED  
as complying with the Florida  
Building Code  
Acceptance No. 26-012602  
Expiration Date 4/21/2031  
By *Iskang J. U...*  
Miami Dade Product Control



Custom Windows and Doors  
3400 PRECISION DRIVE  
N. VENICE, FL 34275  
(941) 480-1600

PREPARED BY A. LYNN MILLER  
1070 TECHNOLOGY DRIVE  
N. VENICE, FL 34275

(941) 480-1600

REGISTRATION #29296

Series	SGD-5470	Sheet	12 OF 21	DWG No.	MD-5470.0	Rev.	E
Title	VINYL SLIDING GLASS DOOR (NI)		Date	10/05/15			
Desc.	ANCHOR LAYOUTS		Drawn By	JENS ROSOWSKI			
Rev			Rev Date	01/15/26			

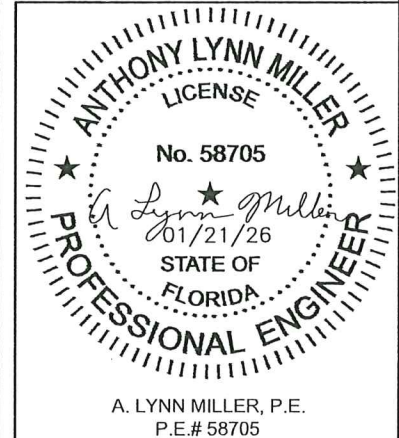

**P-HOOK ANCHORS LAYOUT:**

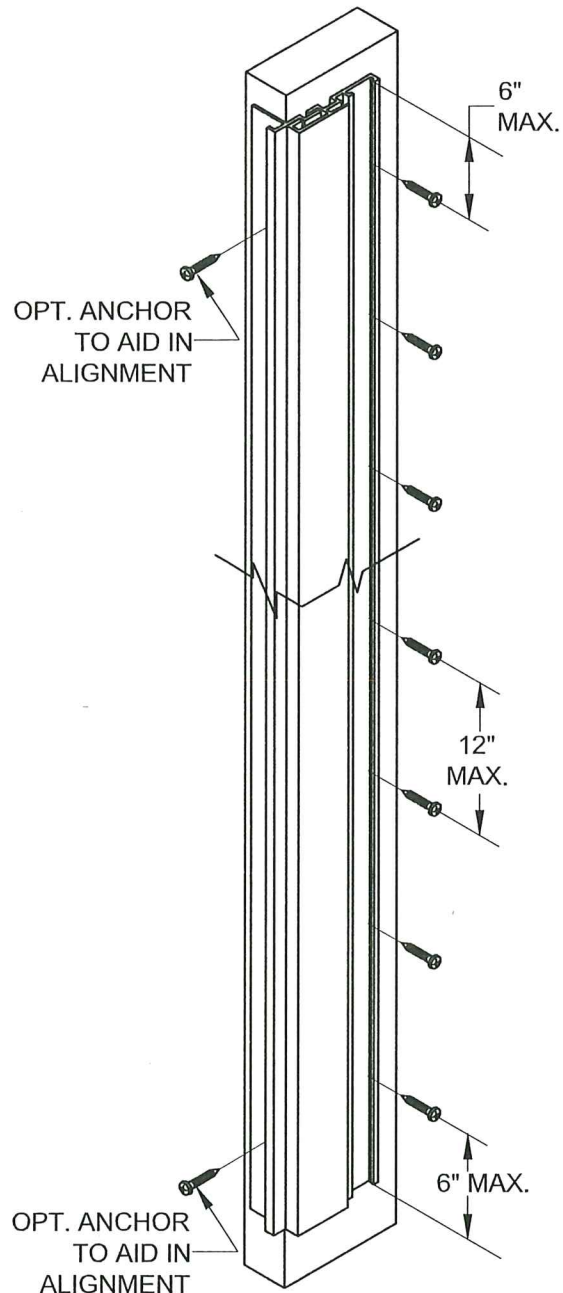

**NOTES:**  
1) SEE TABLES 1 & 2 FOR EXACT QUANTITY OF ANCHORS REQUIRED IN THE P-HOOK.

FIGURES PERTAIN TO THE FOLLOWING POCKET JAMB (P-HOOK) ANCHOR LOCATIONS:

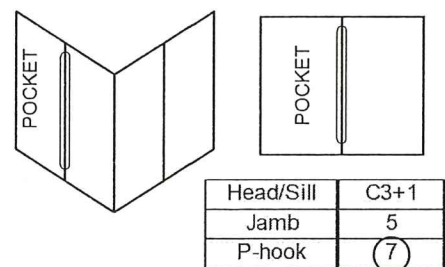

**JAMB ANCHORS LAYOUT, (PARTIAL VIEW):**

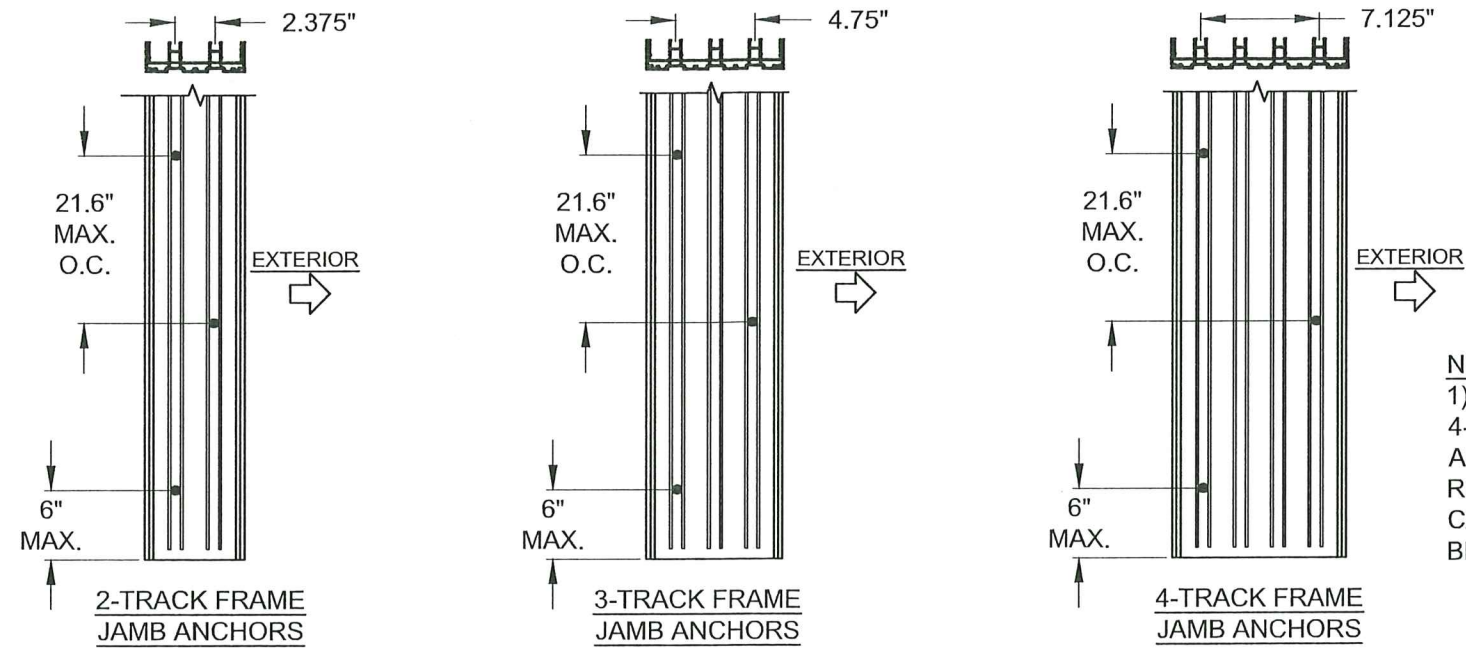

FIGURES PERTAIN TO THE FOLLOWING JAMB ANCHOR LOCATIONS:

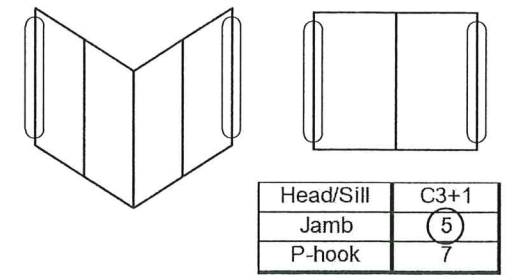

**NOTES:**  
1) STANDARD ANCHOR LOCATIONS SHOWN. FOR 3 AND 4-TRACK JAMBS, ANCHORS MAY BE LOCATED IN ANY ADJACENT TRACK (SIMILAR TO THE 2-TRACK JAMB) AS REQUIRED TO MEET MIN. EDGE DISTANCE CONSTRAINTS. IN CASE OF AN ODD NUMBER OF ANCHORS, THE MAJORITY MAY BE TOWARD THE INTERIOR OR EXTERIOR.

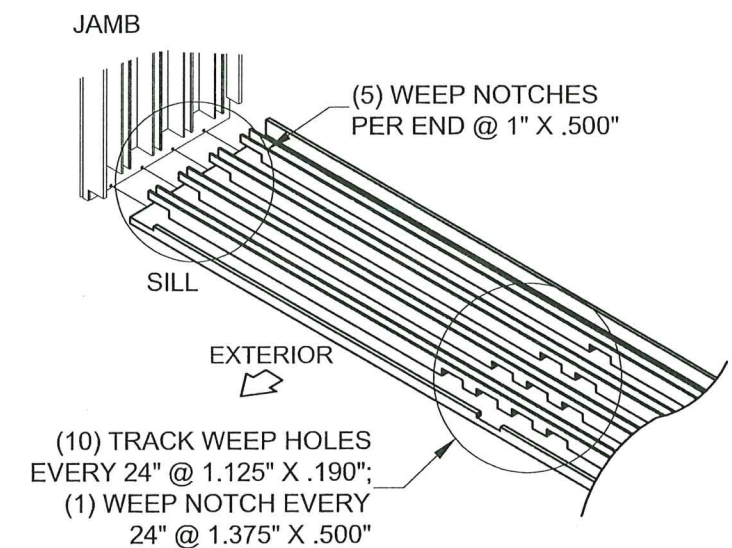
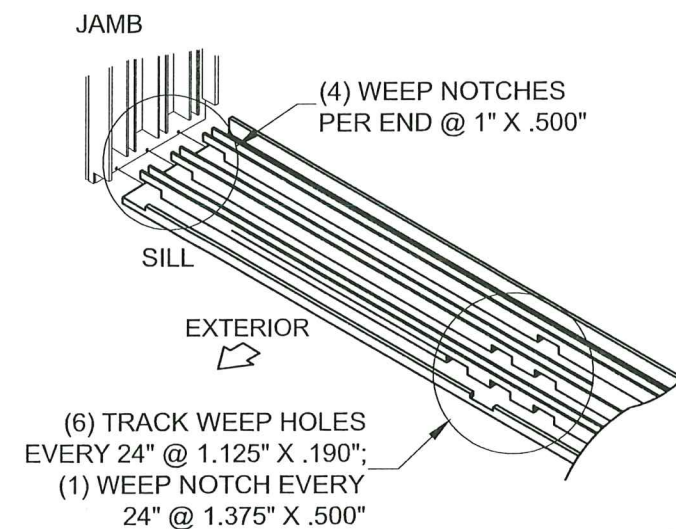
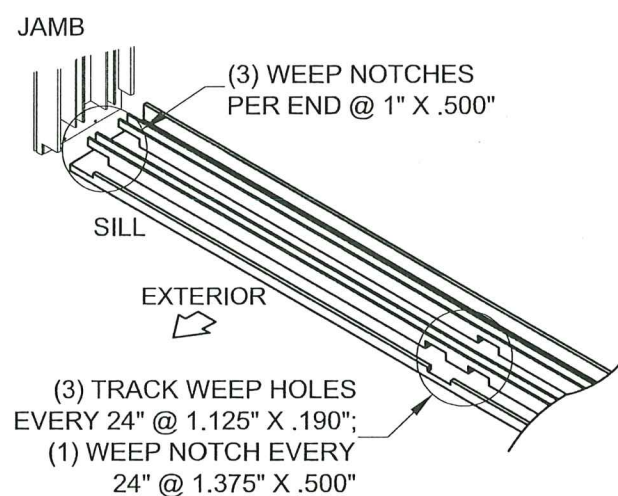

**SILL WEEPHOLE LAYOUT (2, 3 & 4 TRACKS)**

<p><b>PGT</b> Custom Windows and Doors 3400 PRECISION DRIVE N. VENICE, FL 34275 (941) 480-1600</p>		PREPARED BY A. LYNN MILLER 1070 TECHNOLOGY DRIVE N. VENICE, FL 34275 (941) 480-1600 REGISTRATION #29296	
		VINYL SLIDING GLASS DOOR (NI) Date 10/05/15	
PRODUCT REVISED as complying with the Florida Building Code Acceptance No. 26-0126-02 Expiration Date 4/21/2031 By <i>L. Chugh</i> Miami Dade Product Control		ANCHOR LAYOUTS Drawn By JENS ROSOWSKI	
Series SGD-5470 Sheet 13 OF 21 DWG No. MD-5470.0 Rev. E		Rev Date 01/15/26	

ANTHONY LYNN MILLER  
LICENSE  
No. 58705  
01/21/26  
STATE OF FLORIDA  
PROFESSIONAL ENGINEER  
A. LYNN MILLER, P.E.  
P.E.# 58705

**HEAD 90° CORNER CLUSTER ANCHORS LAYOUT:**

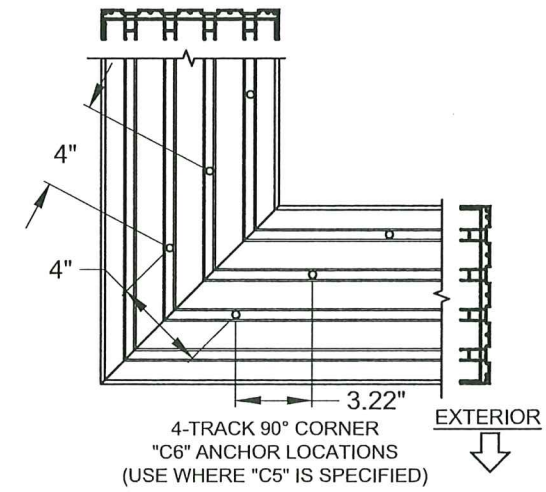
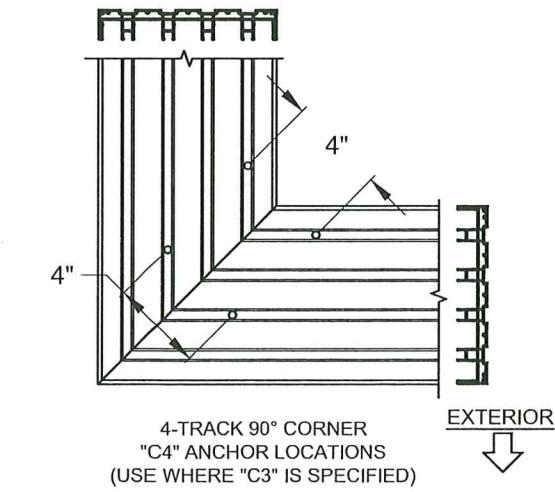
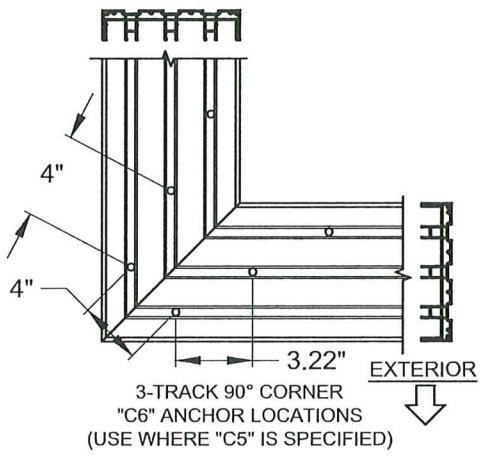
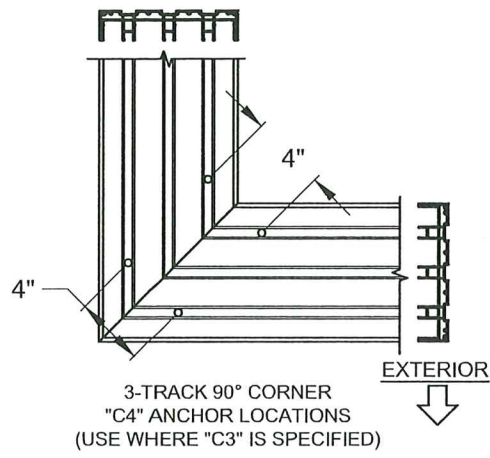
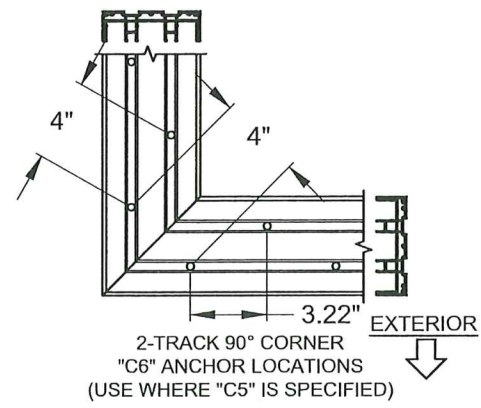
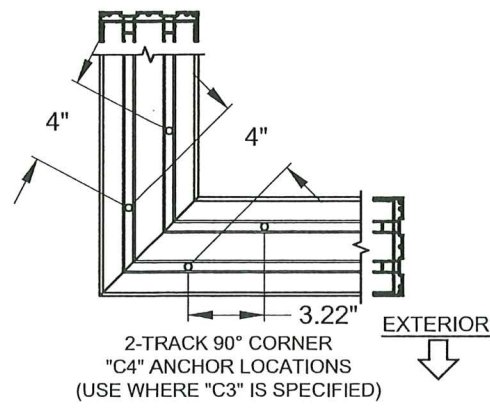

**SILL 90° CORNER CLUSTER ANCHORS LAYOUT:**

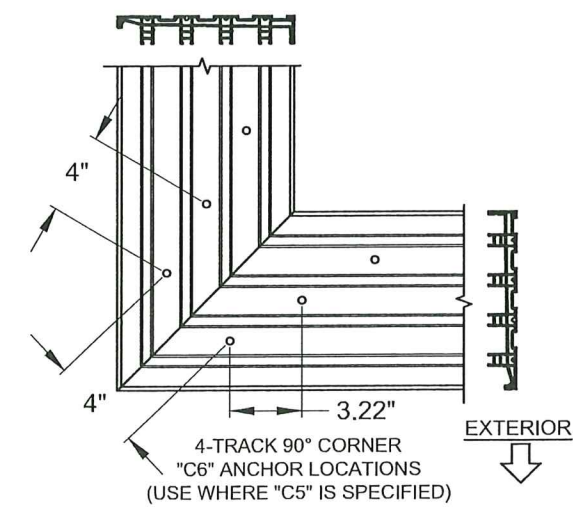
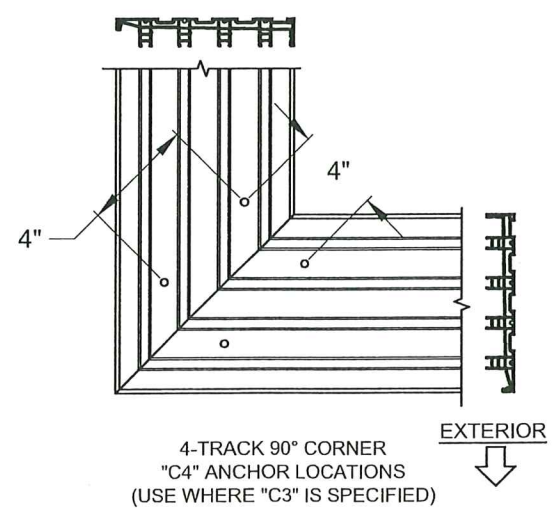
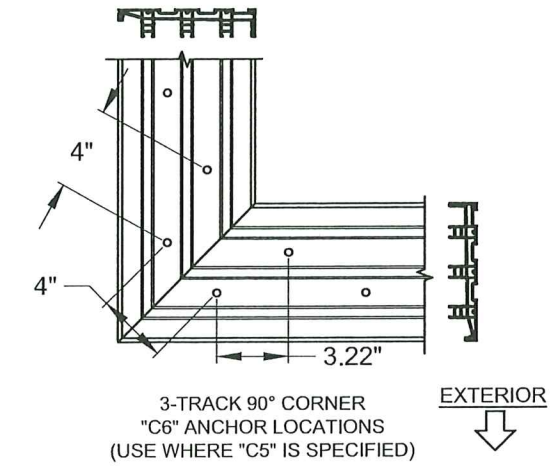
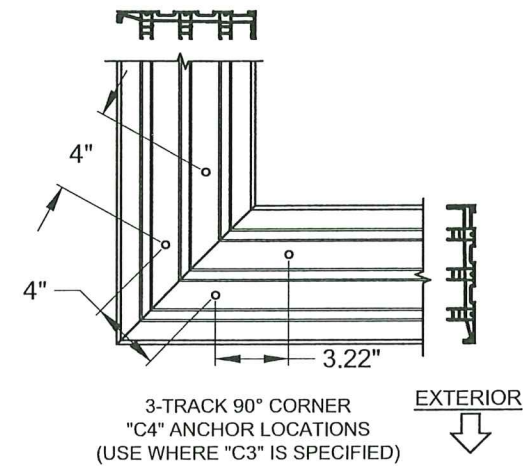
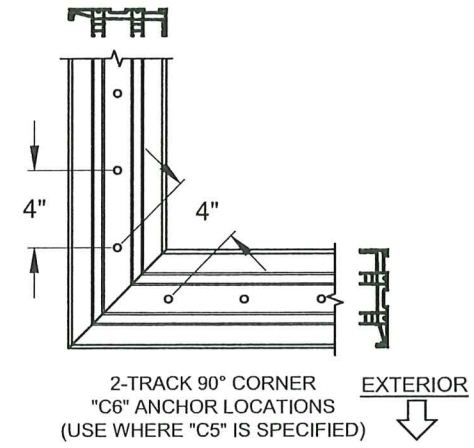
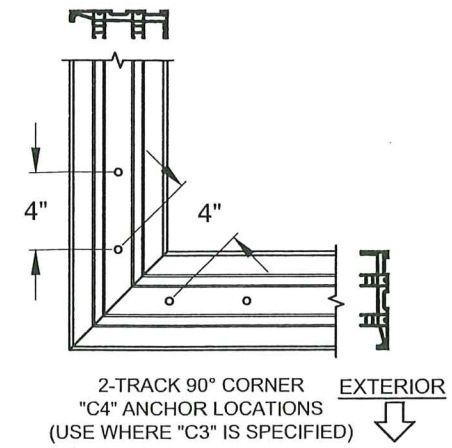

FIGURES PERTAIN TO THE FOLLOWING 90° CORNER HEAD ANCHOR LOCATIONS:

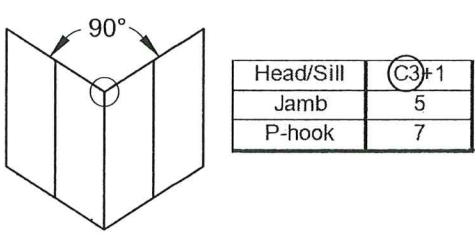

**NOTES:**

- 1) ALL DIMENSIONS SHOWN ARE BASED ON MINIMUM ALLOWED.
- 2) DETAILS DEPICT ANCHOR QUANTITY AND SPACING, AND WOULD BE SIMILAR FOR OUTSIDE (SHOWN) AND INSIDE CORNER CONFIGURATIONS.
- 3) TRACK-TO-TRACK DISTANCE IS 2.375" FOR ALL HEADS AND SILLS:

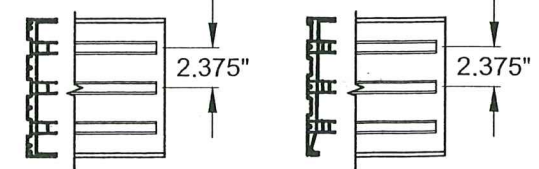

FIGURES PERTAIN TO THE FOLLOWING 90° CORNER SILL ANCHOR LOCATIONS:

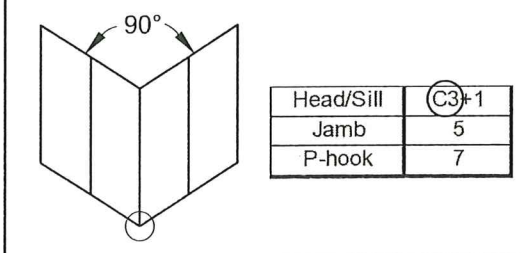

PRODUCT REVISED  
as complying with the Florida  
Building Code  
Acceptance No. 26-0126.02  
Expiration Date 4/21/2031  
By *Anthony Lynn Miller*  
Miami Dade Product Control

Revision:

PREPARED BY A. LYNN MILLER 1070 TECHNOLOGY DRIVE N. VENICE, FL 34275 (941) 480-1600	REGISTRATION #29296	Date	10/05/15	Rev	E
	VINYL SLIDING GLASS DOOR (NI)	Drawn By	JENS ROSOWSKI	DWG No.	MD-5470.0
ANCHOR LAYOUTS	Sheet	14 OF 21			
SGD-5470	Series Desc.				

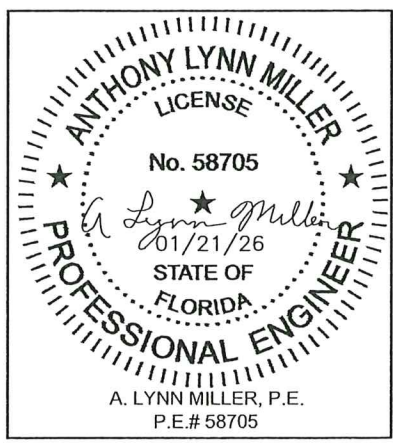

**HEAD 135° CORNER CLUSTER ANCHORS LAYOUT:**

**SILL 135° CORNER CLUSTER ANCHORS LAYOUT:**

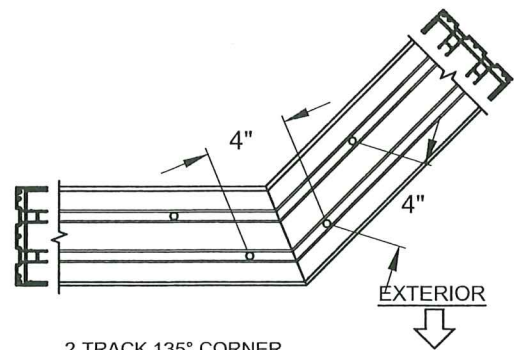

2-TRACK 135° CORNER  
"C4" ANCHOR LOCATIONS  
(USE WHERE "C3" IS SPECIFIED)

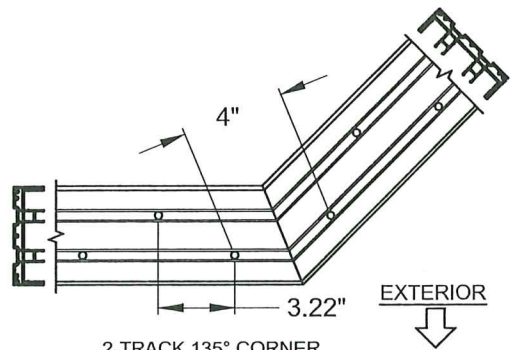

2-TRACK 135° CORNER  
"C6" ANCHOR LOCATIONS  
(USE WHERE "C5" IS SPECIFIED)

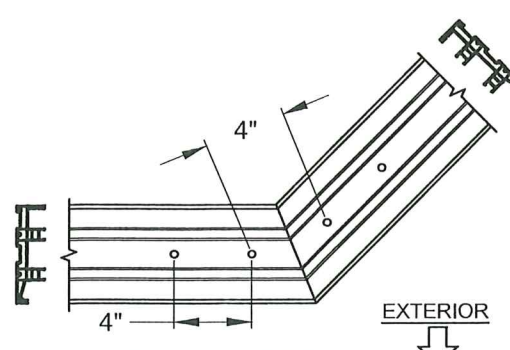

2-TRACK 135° CORNER  
"C4" ANCHOR LOCATIONS  
(USE WHERE "C3" IS SPECIFIED)

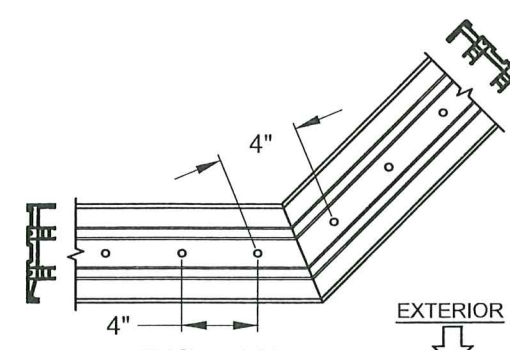

2-TRACK 135° CORNER  
"C6" ANCHOR LOCATIONS  
(USE WHERE "C5" IS SPECIFIED)

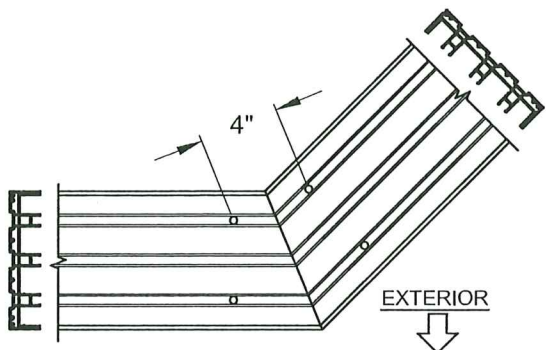

3-TRACK 135° CORNER  
"C4" ANCHOR LOCATIONS  
(USE WHERE "C3" IS SPECIFIED)

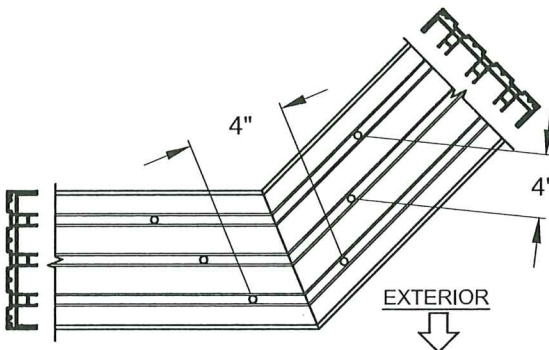

3-TRACK 135° CORNER  
"C6" ANCHOR LOCATIONS  
(USE WHERE "C5" IS SPECIFIED)

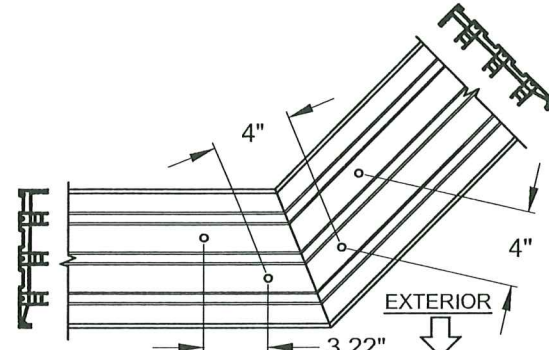

3-TRACK 135° CORNER  
"C4" ANCHOR LOCATIONS  
(USE WHERE "C3" IS SPECIFIED)

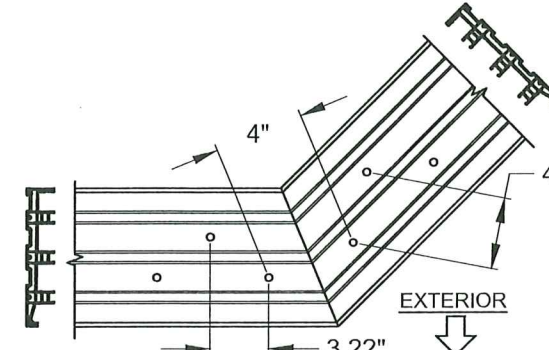

3-TRACK 135° CORNER  
"C6" ANCHOR LOCATIONS  
(USE WHERE "C5" IS SPECIFIED)

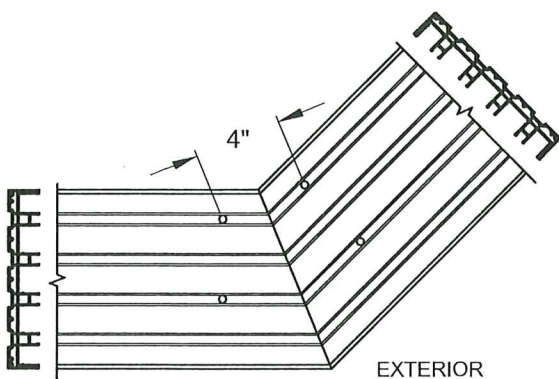

4-TRACK 135° CORNER  
"C4" ANCHOR LOCATIONS  
(USE WHERE "C3" IS SPECIFIED)

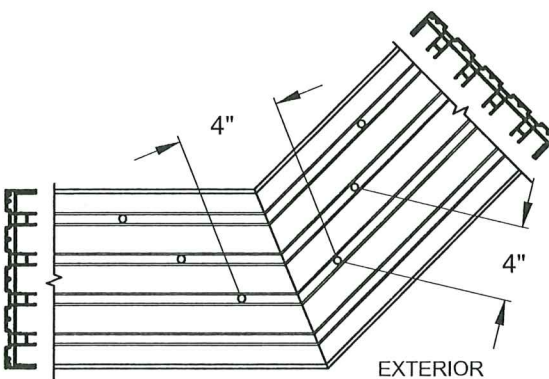

4-TRACK 135° CORNER  
"C6" ANCHOR LOCATIONS  
(USE WHERE "C5" IS SPECIFIED)

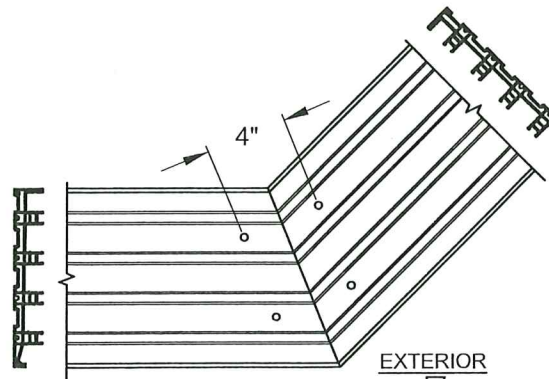

4-TRACK 135° CORNER  
"C4" ANCHOR LOCATIONS  
(USE WHERE "C3" IS SPECIFIED)

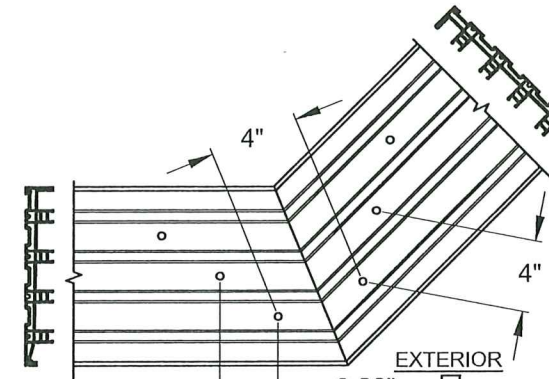

4-TRACK 135° CORNER  
"C6" ANCHOR LOCATIONS  
(USE WHERE "C5" IS SPECIFIED)

**NOTES:**

- 1) ALL DIMENSIONS SHOWN ARE BASED ON MINIMUM ALLOWED.
- 2) DETAILS DEPICT ANCHOR QUANTITY AND SPACING, AND WOULD BE SIMILAR FOR OUTSIDE (SHOWN) AND INSIDE CORNER CONFIGURATIONS.
- 3) TRACK-TO-TRACK DISTANCE IS 2.375" FOR ALL HEADS AND SILLS:

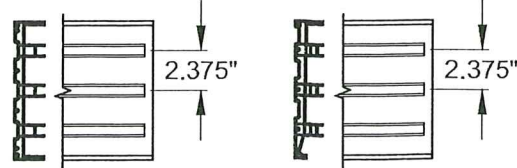

FIGURES PERTAIN TO THE FOLLOWING 135° CORNER HEAD ANCHOR LOCATIONS:

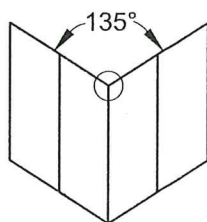

Head/Sill	(C3)+1
Jamb	5
P-hook	7

FIGURES PERTAIN TO THE FOLLOWING 135° CORNER SILL ANCHOR LOCATIONS:

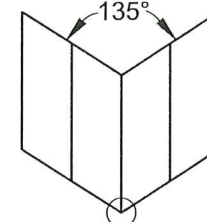

Head/Sill	(C3)+1
Jamb	5
P-hook	7

PRODUCT REVISED  
as complying with the Florida  
Building Code  
Acceptance No 26-0126.02  
Expiration Date 4/21/2031  
By *[Signature]*  
Miami Dade Product Control

Revision:

PREPARED BY A. LYNN MILLER 1070 TECHNOLOGY DRIVE N. VENICE, FL 34275 (941) 480-1600	REGISTRATION #29296	Date 10/05/15	Rev. E
	VINYL SLIDING GLASS DOOR (NI) ANCHOR LAYOUTS	By JENS ROSOWSKI	DWG No. MD-5470.0
PGT Custom Windows and Doors 3400 PRECISION DRIVE N. VENICE, FL 34275 (941) 480-1600	Sheet SGD-5470	Title ANCHOR LAYOUTS	15 OF 21

ANTHONY LYNN MILLER  
LICENSE  
No. 58705  
01/21/26  
STATE OF FLORIDA  
PROFESSIONAL ENGINEER  
A. LYNN MILLER, P.E.  
P.E.# 58705

**HEAD SPLICE ANCHORS LAYOUT @ INTERLOCK OR ASTRAGAL:**

**SILL SPLICE ANCHORS LAYOUT @ INTERLOCK OR ASTRAGAL:**

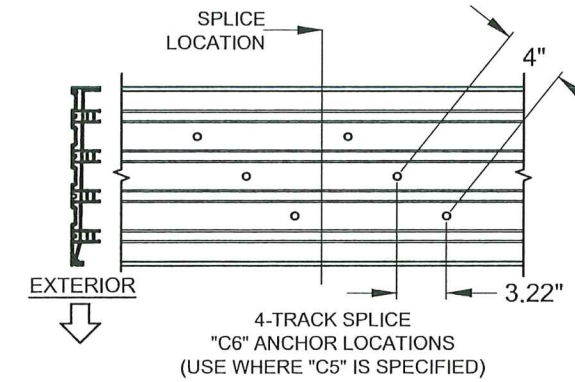
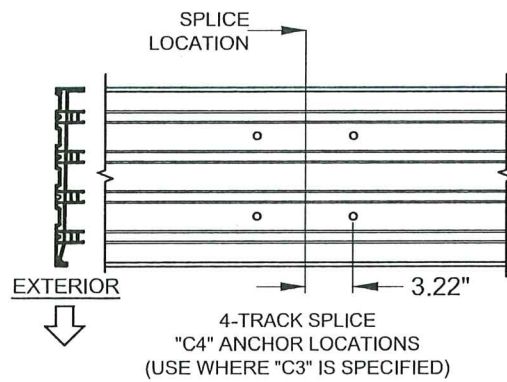
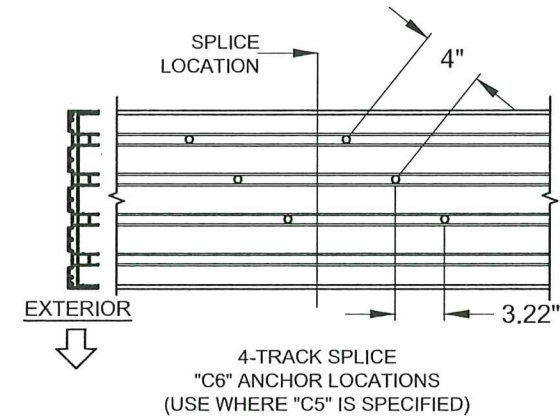
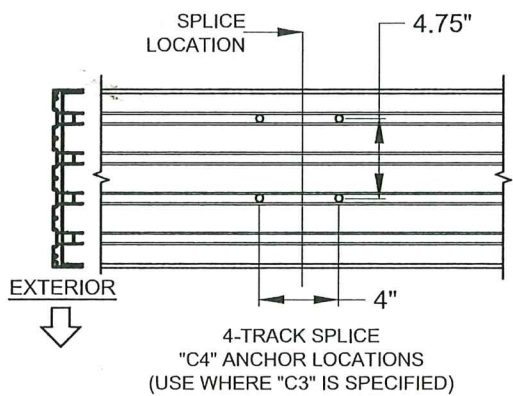
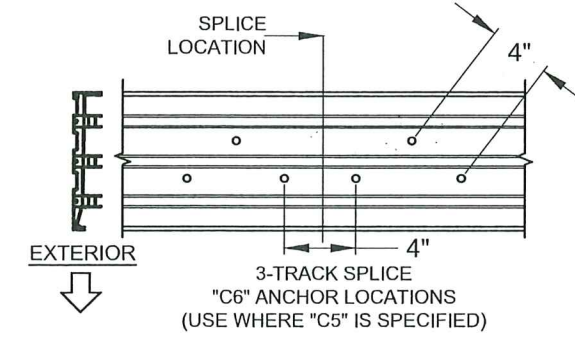
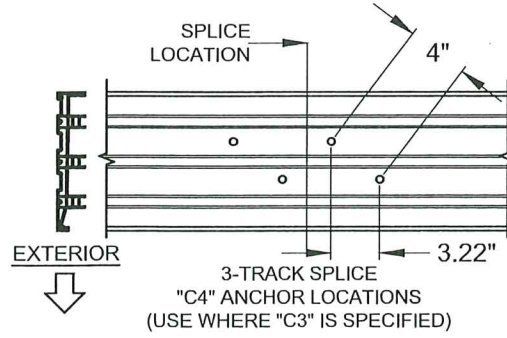
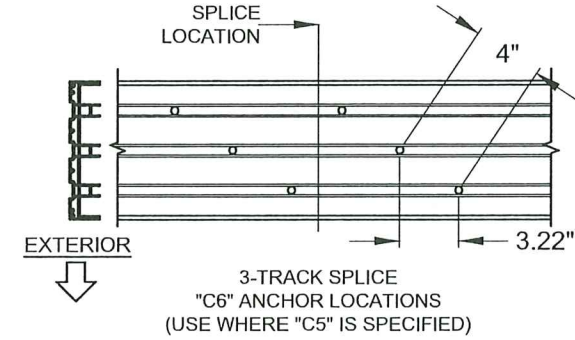
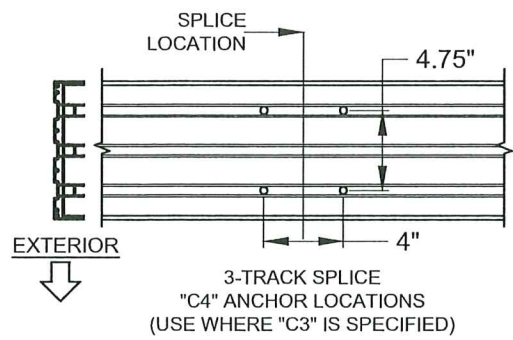
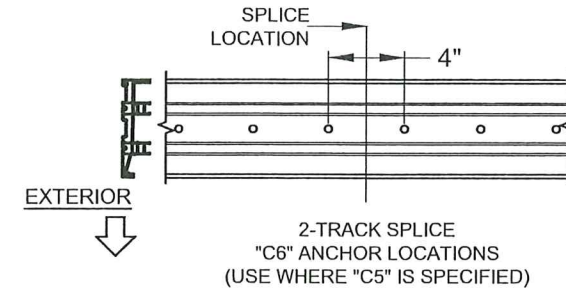
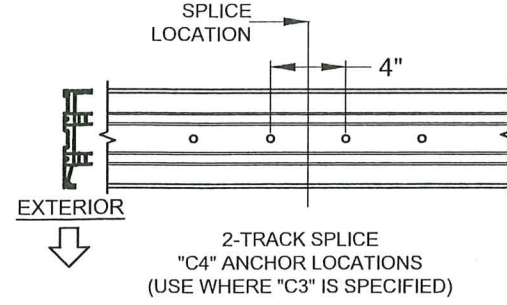
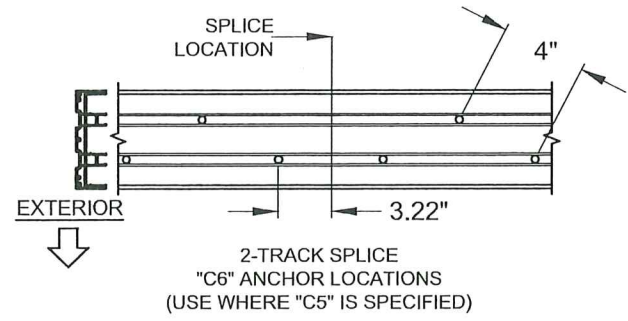
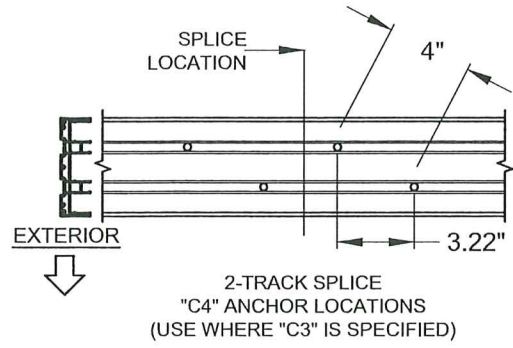

**NOTES:**

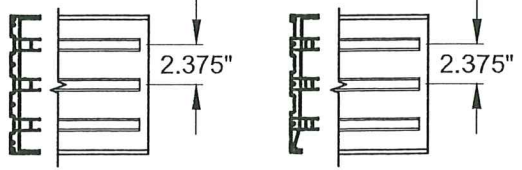
- 1) ALL DIMENSIONS SHOWN ARE BASED ON MINIMUM ALLOWED.
- 2) ABOVE FIGURES ARE FOR SPLICES OCCURRING AT THE ASTRAGAL OR INTERLOCK. FOR SPLICES OCCURRING INSIDE OF A POCKET, SEE THE EXAMPLE ON SHEET 9.
- 3) TRACK-TO-TRACK DISTANCE IS 2.375" FOR ALL HEADS AND SILLS:
 
- 4) POCKET WALL OR CAVITY IS NOT PART OF THIS APPROVAL AND IS TO BE DESIGNED BY OTHERS AND REVIEWED BY THE AUTHORITY HAVING JURISDICTION.

FIGURES PERTAIN TO THE FOLLOWING SPLICED HEAD ANCHOR LOCATIONS:

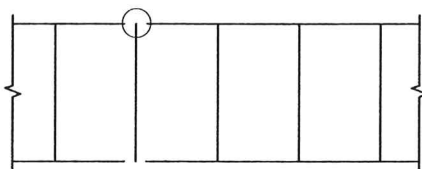

Head/Sill	(C3)+1
Jamb	5
P-hook	7

FIGURES PERTAIN TO THE FOLLOWING SPLICED SILL ANCHOR LOCATIONS:

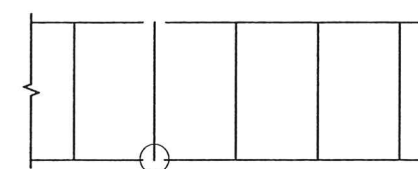

Head/Sill	(C3)+1
Jamb	5
P-hook	7

PRODUCT REVISED as complying with the Florida Building Code  
 Acceptance No. 2620126.02  
 Expiration Date 4/21/2031  
 By 124-91.Ch-J  
 Miami Dade Product Control

Revision:

PREPARED BY A. LYNN MILLER  
 1070 TECHNOLOGY DRIVE  
 N. VENICE, FL 34275

**PGT**  
 Custom Windows and Doors  
 3400 PRECISION DRIVE  
 N. VENICE, FL 34275  
 (941) 480-1600

REGISTRATION #29296	Date	10/05/15	Rev.	E
VINYL SLIDING GLASS DOOR (NI)	Drawn By	JENS ROSOWSKI	DWG No.	MD-5470.0
ANCHOR LAYOUTS	Sheet	SGD-5470	16 OF 21	

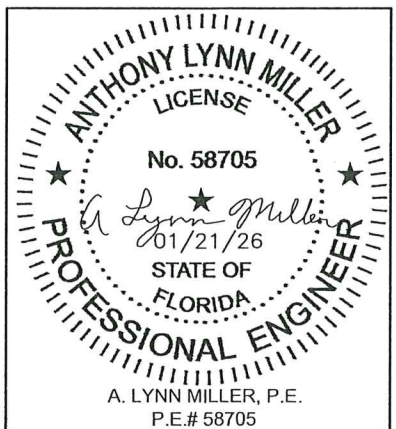

PANEL TYPES INTERIOR OR EXTERIOR GLAZED		PANEL'S RIGHT STILE TYPE										
		SINGLE INTERLOCK OUT	SINGLE INTERLOCK IN	FIXED STILE	LOCKSTILE W/ HANDLE	ASTRAGAL BOX OUT	ASTRAGAL BOX IN	OUTSIDE 90° ASTRAGAL RECEIVER	INSIDE 90° ASTRAGAL RECEIVER	OUTSIDE 135° ASTRAGAL RECEIVER	INSIDE 135° ASTRAGAL RECEIVER	
PANEL'S LEFT STILE TYPE	SINGLE INTERLOCK OUT		F	PP	K	L (BOX OUT)	L (BOX IN)	TC	TA	TV	TW	
	SINGLE INTERLOCK IN		B	E	P	A	C (BOX OUT)	C (BOX IN)	SC	SA	SV	SW
	FIXED STILE		RR	R			S (BOX OUT)	S (BOX IN)	FC	FD	FV	FW
	LOCKSTILE W/ HANDLE		D	M			J (BOX OUT)	J (BOX IN)				
	ASTRAGAL BOX OUT		LR (BOX OUT)		T (BOX OUT)	U (BOX OUT)						
	ASTRAGAL BOX IN			N (BOX IN)	T (BOX IN)	U (BOX IN)						
	OUT. 90° ASTRAGAL RECEIVER		CT	CS	CF							
	IN. 90° ASTRAGAL RECEIVER		AT	AS	DF							
	OUT. 135° ASTRAGAL RECEIVER		VT	VS	VF							
	IN. 135° ASTRAGAL RECEIVER		WT	WS	WF							

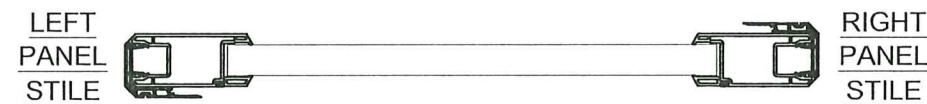

PANEL TYPE "F" SHOWN.

SCREEN PANEL TYPES			
C	DOUBLE INTERLOCK		ASTRAGAL
M	LOCKSTILE		DOUBLE INTERLOCK
J	LOCKSTILE		ASTRAGAL
SD	SINGLE INTERLOCK		DOUBLE INTERLOCK
A	DOUBLE INTERLOCK		LOCKSTILE
U	ASTRAGAL		LOCKSTILE
DS	DOUBLE INTERLOCK		SINGLE INTERLOCK

PANEL NOTES:

- 1) SEE DP/ANCHOR TABLES 1 & 2, SHEETS 7-8 FOR PANEL SIZES & DESIGN PRESSURE.
- 2) PANEL TYPES NOT SHOWN ARE NOT REQUIRED FOR ANY CONFIGURATIONS AND ARE NOT AVAILABLE.
- 3) MAXIMUM NOMINAL PANEL WIDTH FOR ALL PANEL CONFIGURATIONS IS 60".
- 4) PANEL TYPE MAY BE EITHER EXTERIOR (STANDARD) OR INTERIOR GLAZED, BOTH TYPES QUALIFIED BY THIS APPROVAL, SEE DETAILS SHEET 10.

PRODUCT REVISED  
as complying with the Florida  
Building Code  
Acceptance No. 20-0126-01  
Expiration Date 4/21/2031  
By A. Lynn Miller  
Miami Dade Product Control

Revision:

PREPARED BY A. LYNN MILLER 1070 TECHNOLOGY DRIVE N. VENICE, FL 34275  <b>PGT</b> Custom Windows and Doors 3400 PRECISION DRIVE N. VENICE, FL 34275 (941) 480-1600	REGISTRATION #29296	10/05/15	Rev.	E
	VINYL SLIDING GLASS DOOR (NI)	JENS ROSOWSKI	DMG No.	MD-5470.0
			Sheet	17 OF 21
PANEL & SPACER TYPES		SGD-5470	Series	

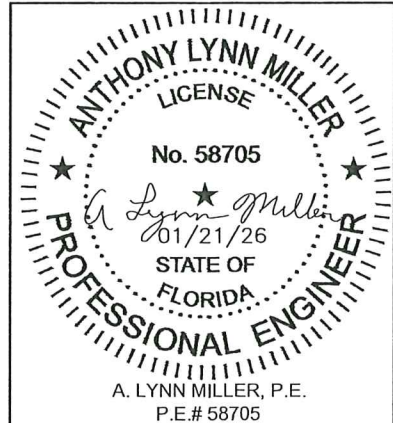

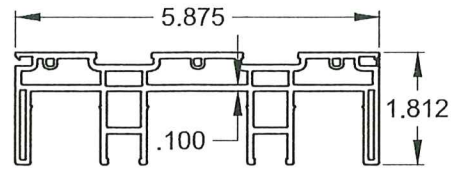

① 2 TRACK HEAD/JAMB

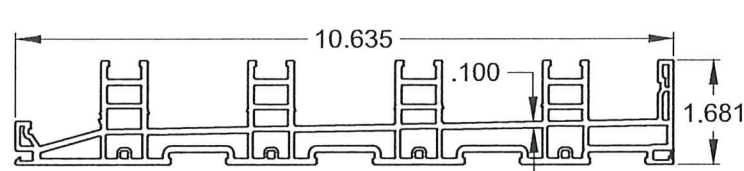

⑥ 4 TRACK SILL

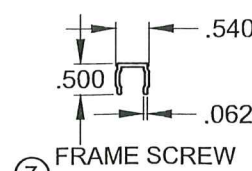

⑦ FRAME SCREW COVER (PVC)

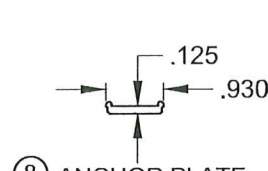

⑧ ANCHOR PLATE

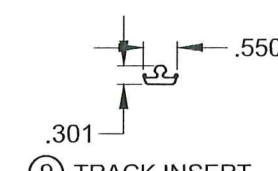

⑨ TRACK INSERT

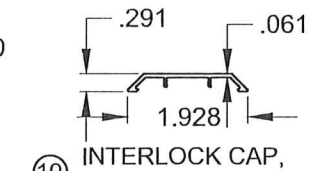

⑩ INTERLOCK CAP, EXTENDED POCKET

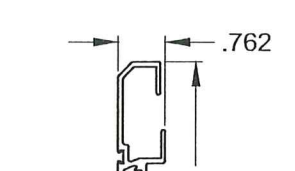

⑱ P-HOOK

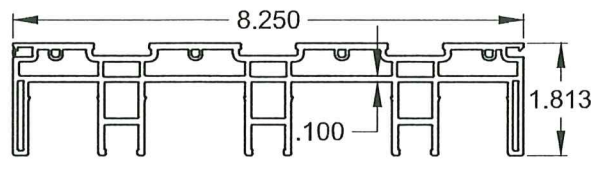

③ 3 TRACK HEAD/JAMB

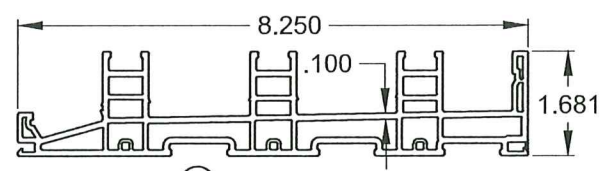

④ 3 TRACK SILL

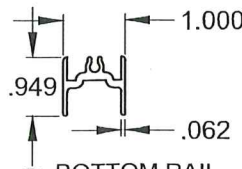

⑪ BOTTOM RAIL SUPPORT

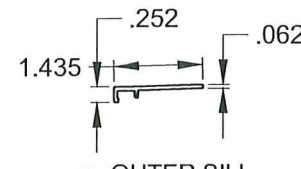

⑫ OUTER SILL COVER

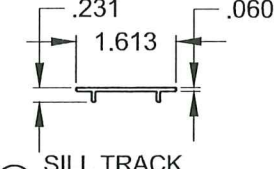

⑬ SILL TRACK COVER

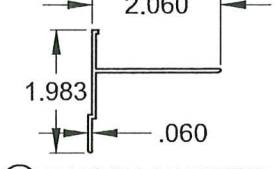

⑰ P-HOOK ADAPTOR

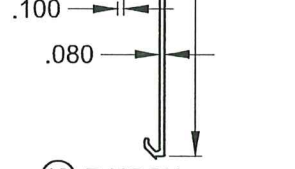

⑱ P-HOOK

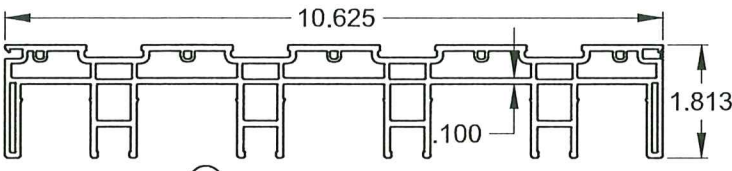

⑤ 4 TRACK HEAD/JAMB

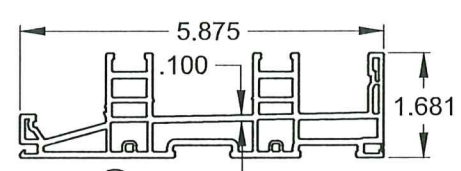

② 2 TRACK SILL

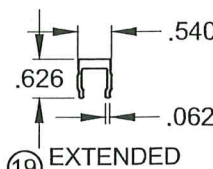

⑲ EXTENDED KEEPER

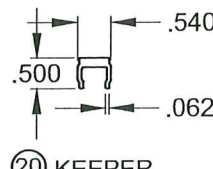

⑳ KEEPER

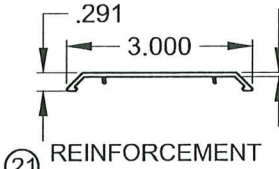

㉑ REINFORCEMENT BAR COVER

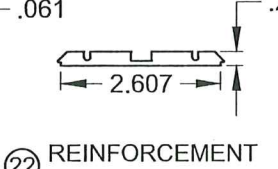

㉒ REINFORCEMENT BAR

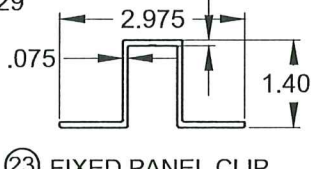

㉓ FIXED PANEL CLIP

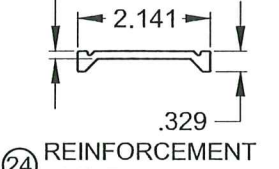

㉔ REINFORCEMENT PLATE

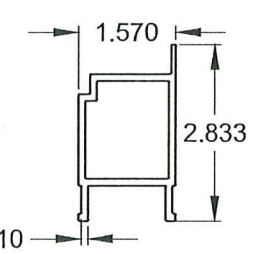

㉕ TOP, BOTTOM AND STILE REINFORCEMENT

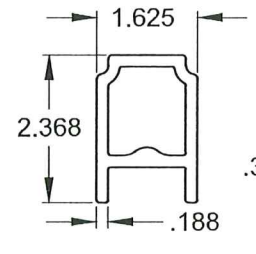

㉖ TOP, BOTTOM AND STILE COMPOSITE REINFORCEMENT

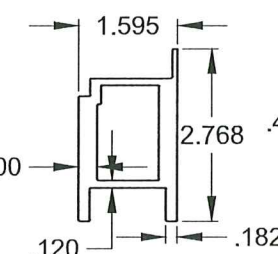

㉗ INTERLOCK .300 REINFORCEMENT, STANDARD

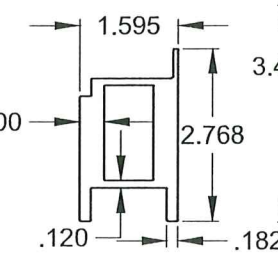

㉘ INTERLOCK .400 REINFORCEMENT, HEAVY-DUTY

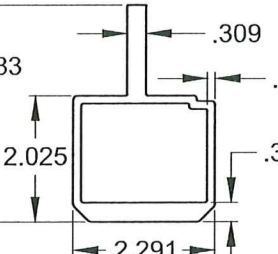

㉙ ASTRAGAL REINFORCEMENT

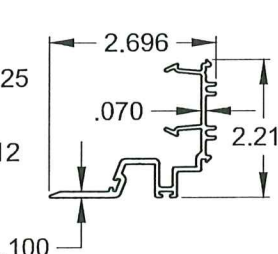

㉚ EXTENDED POCKET INTERLOCK ADAPTER

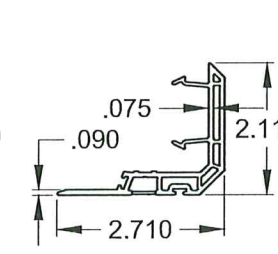

㉛ INTERLOCK ADAPTER

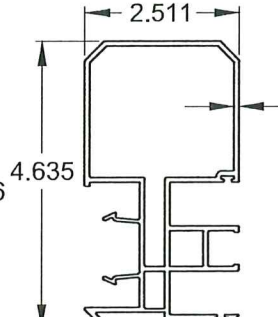

㉜ ASTRAGAL ADD-ON

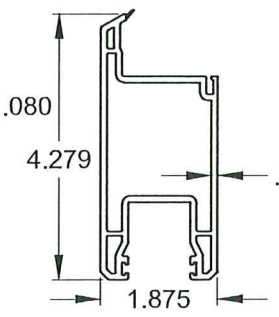

㉝ PANEL STILE, TOP AND BOTTOM RAIL

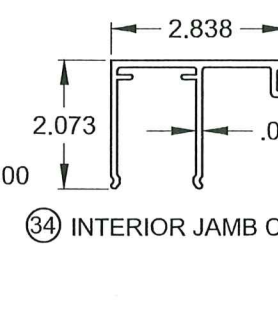

㉞ INTERIOR JAMB COVER

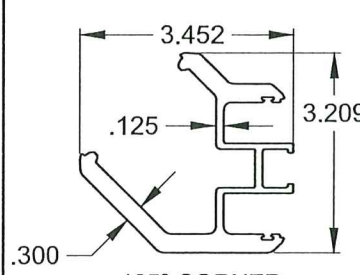

㉟ 135° CORNER ASTRAGAL

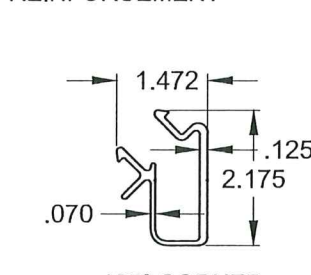

㊱ 135° CORNER PASSIVE MOUNT

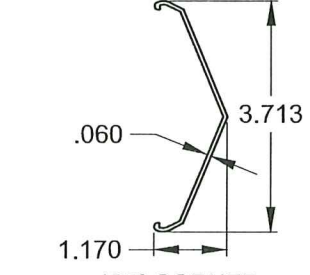

㊲ 135° CORNER ASTRAGAL CAP, EXTERIOR

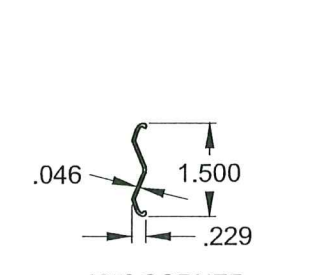

㊳ 135° CORNER ASTRAGAL CAP, INTERIOR

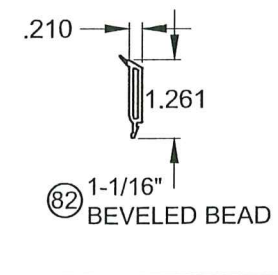

㊴ 1-1/16" BEVELED BEAD

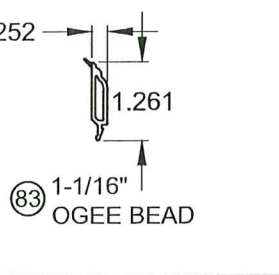

㊵ 1-1/16" OGEE BEAD

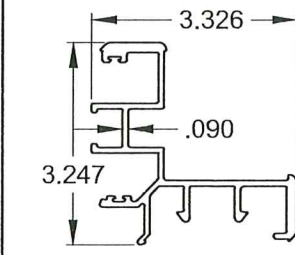

㊶ 90° CORNER ASTRAGAL

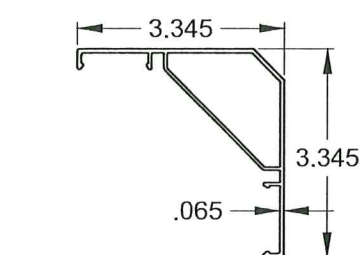

㊷ 90° CORNER ASTRAGAL CAP, EXTERIOR

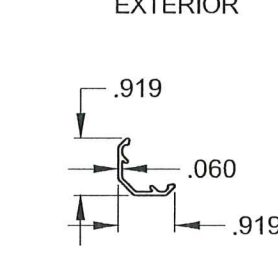

㊸ 90° CORNER ASTRAGAL CAP, INTERIOR

NOTES:

- 1) SEE SHEET 4 FOR SILL RISERS.
- 2) SEE SHEET 20 FOR SCREEN PARTS.
- 3) ALL DIMENSIONS IN INCHES.

PRODUCT REVISED as complying with the Florida Building Code  
 Acceptance No. 26-0126-02  
 Expiration Date 4/21/2031  
 By [Signature]  
 Miami Dade Product Control

<b>PGT</b> Custom Windows and Doors 3400 PRECISION DRIVE N. VENICE, FL 34275 (941) 480-1600		PREPARED BY A. LYNN MILLER 1070 TECHNOLOGY DRIVE N. VENICE, FL 34275 (941) 480-1600 REGISTRATION #29296	
Series	Rev	Title	Date
SGD-5470		VINYL SLIDING GLASS DOOR (NI)	10/05/15
Desc.		EXTRUSIONS	
Rev		Drawn By	JENS ROSOWSKI
		Rev Date	01/15/26
Sheet	18 OF 21	DWG No.	MD-5470.0
		Rev.	E

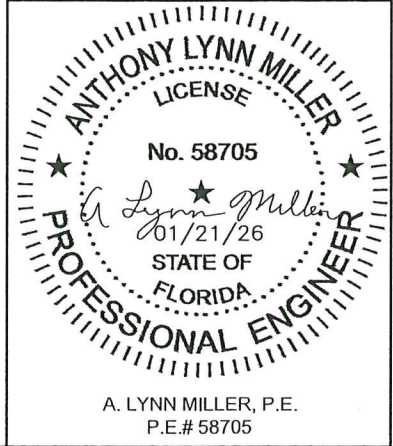

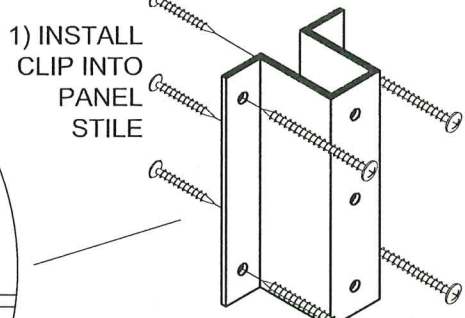
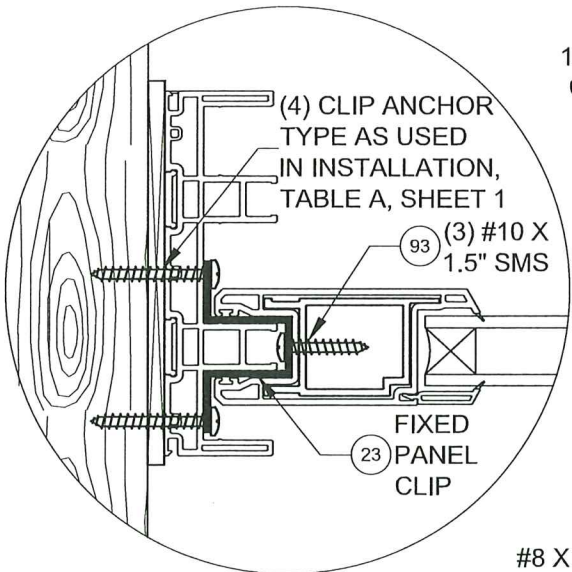

2) INSTALL CLIP INTO FRAME JAMB & SUBSTRATE, USING 4 INSTALLATION ANCHORS, SEE TABLE 1

**HEADER BLOCK TO HEAD ATTACHMENT**

INSTALL ONE BLOCK AT EACH INTERLOCK. AT ASTRAGAL, INSTALL ONE BLOCK THAT SPANS BOTH PANELS.

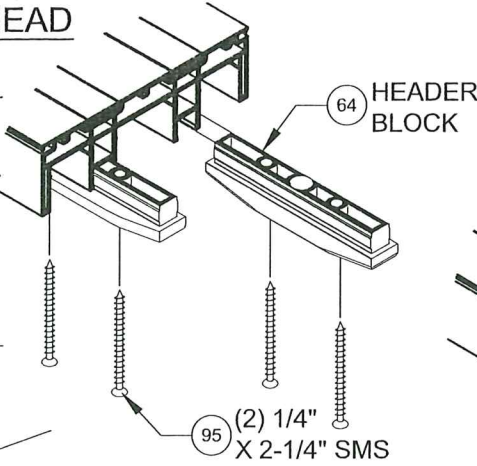

**JAMB TO HEAD ASSEMBLY**

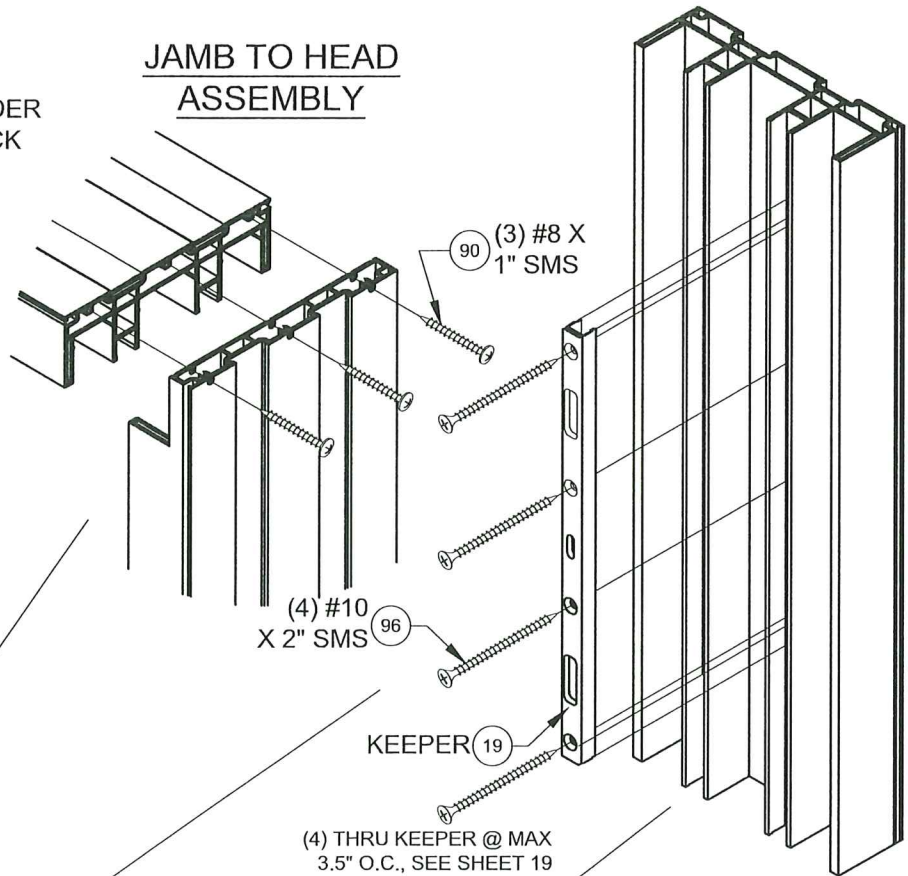

**KEEPER TO JAMB ATTACHMENT**

(23) **FIXED PANEL CLIP**  
INSTALL ONE CLIP AT THE MIDSPAN OF EACH PANEL-TO-FRAME JAMB LOCATION.

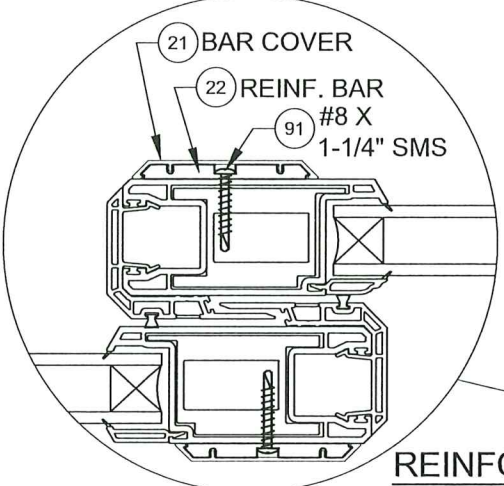
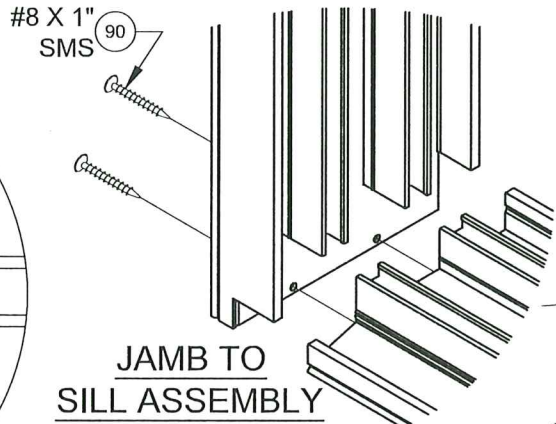

ATTACH WITH #8 X 1-1/4" @ 34-1/2" MAX O.C.

4-PANEL, 2-TRACK OXXX SHOWN

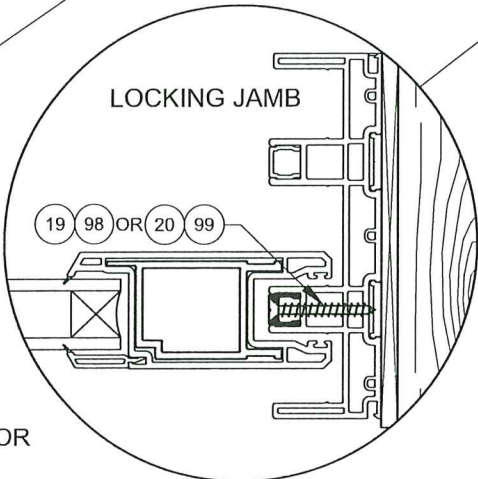

**NOTES**  
1) DETAILS APPLY TO 2, 3 AND 4 TRACK CONFIGURATIONS.  
2) SEE SHEETS 11-16 FOR ANCHOR LOCATION & SPACING.  
3) SEE TABLES 1 & 2 FOR REINFORCEMENT REQUIREMENTS.  
4) CONTINUOUS ANCHOR PLATE, ITEM #8, IS REQUIRED AT ALL FRAME ANCHOR LOCATIONS.

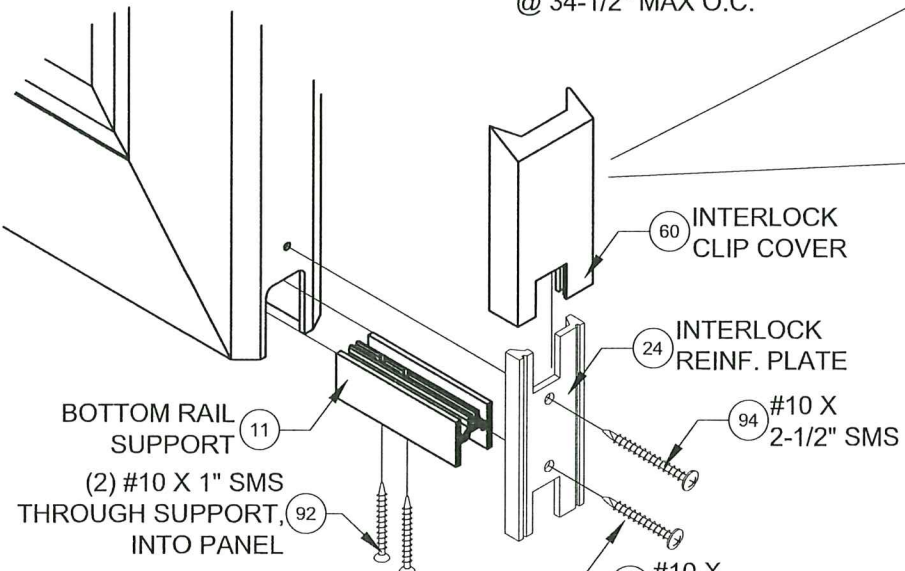

**INTERLOCK SILL RETAINER CLIP ATTACHMENT**

INSTALL ONE ASSEMBLY AT EACH INTERLOCK

**PANEL ASSEMBLY**

ALL PANEL CORNERS WELDED, NO ASSEMBLY FASTENERS

INTERIOR  
EXTERIOR

<b>PGT</b> Custom Windows and Doors 3400 PRECISION DRIVE N. VENICE, FL 34275 (941) 480-1600		PREPARED BY A. LYNN MILLER 1070 TECHNOLOGY DRIVE N. VENICE, FL 34275 (941) 480-1600	
REGISTRATION #29296			
Series	Rev	Title	Date
SGD-5470		VINYL SLIDING GLASS DOOR (NI)	10/05/15
Desc.	Rev	Drawn By	Rev Date
ACCESSORY INSTALLATION		JENS ROSOWSKI	01/15/26
Sheet	DWG No.	Rev.	
19 OF 21	MD-5470.0	E	

**PRODUCT REVISED**  
as complying with the Florida Building Code  
Acceptance No. 26-0126-02  
Expiration Date 4/21/2031  
By: [Signature]  
Miami Dade Product Control

ANTHONY LYNN MILLER  
LICENSE  
No. 58705  
01/21/26  
STATE OF FLORIDA  
PROFESSIONAL ENGINEER  
A. LYNN MILLER, P.E.  
P.E.# 58705

**BOX SCREEN DETAILS:**

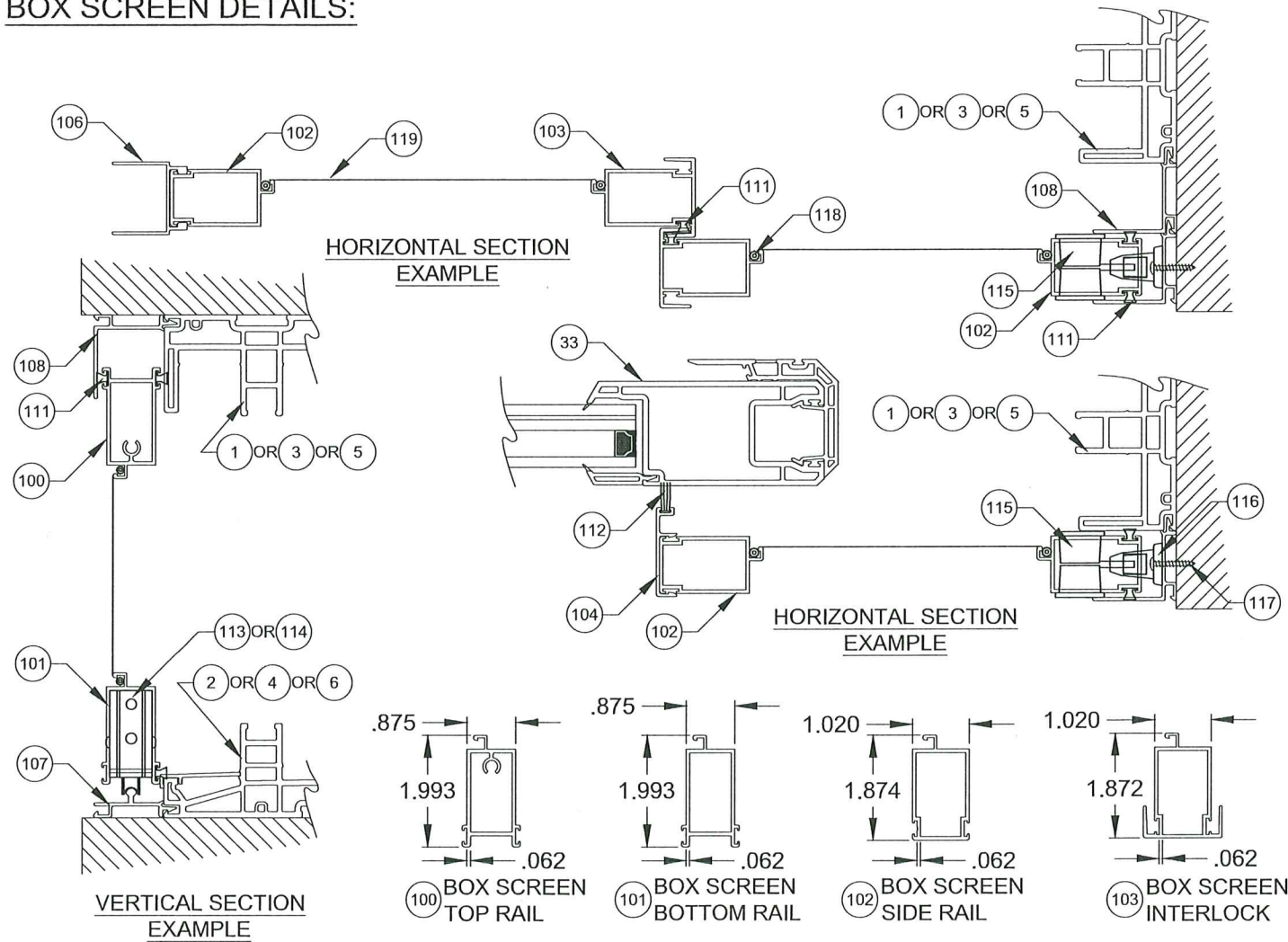

**TABLE C: BOX SCREEN**

#	Part #	Description	Material
100	12256	Box Screen Top Rail	6063 T5 Al
101	12257	Box Screen Bottom Rail	6063 T5 Al
102	12258	Box Screen Side Rail	6063 T5 Al
103	64428	Box Screen Interlock	6063 T6 Al
104	17347A	Box Screen Snap-on Bug Flap	6063 T6 Al
105	64345	Box Screen OXO Astragal Adapter	6063 T6 Al
106	17349	Box Screen Astragal Adapter	6063 T5 Al
107	19039	Box Screen Frame Sill Add-on	6063 T6 Al
108	19038	Box Screen Head/Jamb Add-on	6063 T6 Al
109	720X1X	#14-20 x 1" MS @ Top Rail	SS
110	720X112X	#14-20 x 1-1/2" MS @ Bottom Rail	SS
111	71793G	Wstp, .270" x .150" - Fin Seal	
112	61805K	Wstp, .187" x .500" @ Bug Flap	
113	7SRAZ	Standard Roller	Nylon
114	7SRAX	HD Roller	SS
115	varies	Screen Locking Hardware	Steel
116	419053	Screen Keeper	Steel
117	76X1PPA	#6 x 1" Ph. PH SMS	Steel
118	1692/3/4	Screen Spline - .150" & .165"	Vinyl
119	1816C20	Screen Cloth	Fiberglass

**STANDARD SCREEN DETAILS:**

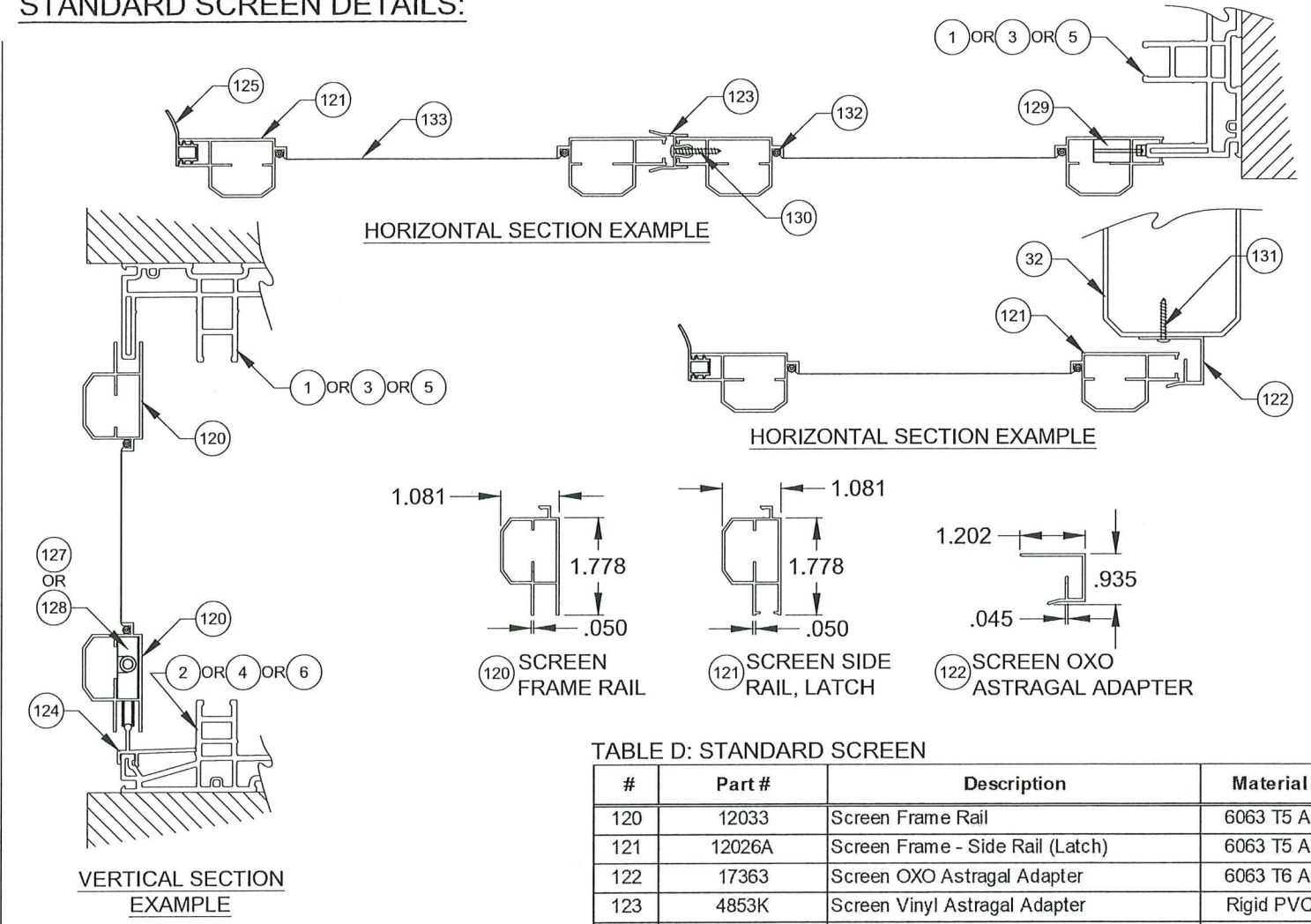

**TABLE D: STANDARD SCREEN**

#	Part #	Description	Material
120	12033	Screen Frame Rail	6063 T5 Al
121	12026A	Screen Frame - Side Rail (Latch)	6063 T5 Al
122	17363	Screen OXO Astragal Adapter	6063 T6 Al
123	4853K	Screen Vinyl Astragal Adapter	Rigid PVC
124	19012B	Frame Sill Screen Add-on	6063 T6 Al
125	6FP95K	Bug Flap, 85 +/- 5 duro.	Vinyl
126	78X112PSATS	#8 x 1-1/2" Ph. PH SMS (Assembly)	SS
127	712027	Comer Key Wheel Assembly (Standard)	Nylon
128	712027SS	Comer Key Wheel Assembly (HD)	SS
129	varies	Screen Locking Hardware	Steel
130	710X34PPSDAX	#10 x 3/4" Ph. PH SMS @ Screen Ast.	SS
131	78X12PPSMSX	#8 x 1/2" Ph. PH SMS @ Door Ast.	SS
132	1692/3/4	Screen Spline - .145"	Vinyl
133	1816C20	Screen Cloth	Fiberglass

**NOTES:**  
1) ALL DIMENSIONS IN INCHES.

**PRODUCT REVISED**  
as complying with the Florida Building Code  
Acceptance No. 26-0126-02  
Expiration Date 4/21/31  
By Jens Rosowski  
Miami Dade Product Control

**PGT**  
Custom Windows and Doors  
3400 PRECISION DRIVE  
N. VENICE, FL 34275  
(941) 480-1600

PREPARED BY A. LYNN MILLER  
1070 TECHNOLOGY DRIVE  
N. VENICE, FL 34275  
(941) 480-1600  
REGISTRATION #29296

VINYL SLIDING GLASS DOOR (NI) Date 10/05/15

SCREEN DETAILS Drawn By JENS ROSOWSKI

Rev Date 01/15/26

SGD-5470 Sheet 20 OF 21 DWG No. MD-5470.0 Rev. E

**ANTHONY LYNN MILLER**  
LICENSE  
No. 58705  
01/21/26  
STATE OF FLORIDA  
PROFESSIONAL ENGINEER  
A. LYNN MILLER, P.E.  
P.E.# 58705

TABLE E:

#	Part #	Description	Material
1	19001	2-Track Head/Jamb	Rigid PVC
2	19002	2-Track Sill	Rigid PVC
3	19025	3-Track Head/Jamb	Rigid PVC
4	19026	3-Track Sill	Rigid PVC
5	19027	4-Track Head/Jamb	Rigid PVC
6	19028	4-Track Sill	Rigid PVC
7	19009	Frame Screw Cover	Rigid PVC
8	19031	Anchor Plate	6063-T6 Alum.
9	19007	Track Insert	6063-T6 Alum.
10	19084	Interlock Cap - Extended Pocket	Rigid PVC
11	19036	Bottom Rail Support	6063-T6 Alum.
12	19006A	Outer Sill Cover	6063-T6 Alum.
13	19011	Sill Track Cover	Rigid PVC
17	19032	P-Hook Adapter	6063-T6 Alum.
18	19020	P-Hook	6063-T6 Alum.
19	19047M	Extended Keeper	6063-T6 Alum.
20	19029M	Keeper	6063-T6 Alum.
21	19014	Reinforcement Bar Cover	Rigid PVC
22	19030	Reinforcement Bar	6005-T5 Alum.
23	19037M	Fixed Panel Clip	6063-T6 Alum.
24	19035M	Reinforcement Plate	6063-T6 Alum.
25	19017M	Top Rail, Bottom Rail and Lockstile	6005-T5 Alum.
26	19046	Reinforcement	Composite
27	19018M	Interlock .300 Reinforcement, Std.	6005-T5 Alum.
28	19013M	Interlock .400 Reinforcement, HD	6005-T5 Alum.
29	19019M	Astragal Reinforcement	6005-T5 Alum.
30	19083	Extended Pocket Interlock Adaptor	6063-T6 Alum.
31	19005	Interlock Adaptor	Rigid PVC
32	19008	Astragal Add-on	Rigid PVC
33	19004	Panel Stile, Top/Bottom Rail	Rigid PVC
34	19040	Interior Jamb Cover	6063-T6 Alum.
35	19076	135° Corner Astragal	6063-T6 Alum.
36	19077	135° Corner Astragal Passive Mount	6063-T6 Alum.
37	19079	135° Corner Astragal Cap - Ext.	Rigid PVC
38	19080	135° Corner Astragal Cap - Int.	Rigid PVC
39	19078	90° Corner Astragal	6063-T6 Alum.
40	19081	90° Corner Astragal Cap - Ext.	Rigid PVC
41	19082	90° Corner Astragal Cap - Int.	Rigid PVC
42	19085	Sill Riser - (2-1/2")	6063-T6 Alum.
43	19022A	Sill Riser - (3-1/2")	6063-T6 Alum.
44	19023A	Sill Riser - (4-1/16")	6063-T6 Alum.
45	19024A	Sill Riser - (4-5/8")	6063-T6 Alum.
50	718609W	.187" x .320" Finseal (Stile)	
51	71695K	1-1/2" x 1" x 3/4" Fin Seal Dust Plug	
52	71696	Dust Plug	
60	419041	Interlock Clip Cover	PVC
61	78153X	Tandem Roller Assembly	SS
62	78153N	Tandem Roller Assembly	Nylon
63	78X75FPTX	#8 x 3/4" Ph. FH SMS @ Roller & Reinf.	SS

#	Part #	Description	Material
64	419042	Frame Header Block	Nylon
65	48052	Roller Adj. Hole Plug	PVC
66	44385	4 Hole Bumper Stop	PVC
67	76X114FPTX	#6 x 1-1/4" Ph. FH SMS @Bumper Stop	SS
68	71696G	Sill Plug	PVC
69	78185X	Gemini Mortise Lock w/long Trim plate	Steel/SS
70	71032X1FPPX	10-32 x 1" Ph.FH MS @ Lock	SS
71	varies	Handle Kit	Cast Zinc
72	19054	Interlock Retainer Clip	Nylon
75		Kommerling 4SG TPS Spacer System	See Sheet 10 for Materials
76		Quanex Super Spacer nXT with Hot Melt Butyl	
77		Quanex Duraseal	
78		Cardinal XL Edge Spacer	
79		Dow 791, 983, 995 or GE-7700 Backbedding	Silicone
82	19044	1-1/16" Beveled Bead	Rigid PVC
83	19045	1-1/16" Ogee Bead	Rigid PVC
86	71726K	Setting Block 1" x 4" x 1/16", 85 +/- 5 duro.	Neoprene
90	781PSTX	#8 x 1" Ph. PH SMS @ Frame Assembly	SS
91	78X114PHPT410X	#8 x 1-1/4" Ph. PH SMS @ Reinf. Bar	SS
92	710X1PHPT18-8X	#10 x 1" Ph. PH SMS @ Rail Support	SS
93	710X115PPX	#10 x 1-1/2" Ph. PH SMS @ Fxd. Pnl. Clip	SS
94	710X2.5PHPT18-8X	#10 x 2-1/2" Ph. PH SMS @ Reinf. Plate/Ast.	SS
95	71420X2.25FPPX	#12 x 2-1/4" Ph. PH SMS @ Hdr. Block	SS
96	710X1.75PPX	#10 x 1-3/4" Ph. FH SMS @ Ast. Mount	SS
97	710X34PPX	#10 x 3/4" Ph. PH SMS @ Ext. Pkt. Int.	SS
98	131001	#10 x 2-1/2" Ph. FH SDS, 4 @ Keeper	SS
99	710X2PPX	#10 x 2" Ph. FH SMS, 4 @ Keeper	SS

NOTES:

1) ITEMS # 14-16, 46-49, 53-59, 72-74, 80, 81, 84, 85 & 87-89 ARE NOT USED AND ARE NOT PART OF THIS APPROVAL.

TABLE F:

Material	Min. F <sub>y</sub>	Min. F <sub>u</sub>
#12 Steel Screw	92 ksi	120 ksi
#12 410 Screw	90 ksi	110 ksi
1/4" DeWalt/Elco Aggre-Gator®	57 ksi	96 ksi
1/4" Elco UltraCon®	155 ksi	177 ksi
1/4" DeWalt UltraCon+®	148 ksi	164 ksi
1/4" 410 SS DeWalt/Elco CreteFlex®	127.4 ksi	189.7 ksi
6063-T5 Aluminum	16 ksi	22 ksi
A36 Steel	36 ksi	58 ksi
Gr. 33 Steel Stud	33 ksi	45 ksi

PRODUCT REVISED  
 is complying with the Florida  
 Building Code  
 Acceptance No. 26-0126.02  
 Expiration Date 4/21/2031  
 By: [Signature]  
 Miami Dade Product Control

<b>PGT</b> Custom Windows and Doors		PREPARED BY A. LYNN MILLER 1070 TECHNOLOGY DRIVE N. VENICE, FL 34275 (941) 480-1600	
3400 PRECISION DRIVE N. VENICE, FL 34275 (941) 480-1600		REGISTRATION #29296	
Series	Title	Date	
	VINYL SLIDING GLASS DOOR (NI)	10/05/15	
Rev.	Desc.	Drawn By	
	PARTS LIST/BOM	JENS ROSOWSKI	
		Rev. Date	01/15/26
SGD-5470	Sheet	21 OF 21	DWG No. MD-5470.0
			Rev. E

ANTHONY LYNN MILLER  
 LICENSE  
 No. 58705  
 A. Lynn Miller  
 01/21/26  
 STATE OF  
 FLORIDA  
 PROFESSIONAL ENGINEER  
 A. LYNN MILLER, P.E.  
 P.E.# 58705