



DEPARTMENT OF REGULATORY AND ECONOMIC RESOURCES (RER)
BOARD AND CODE ADMINISTRATION DIVISION

MIAMI-DADE COUNTY
PRODUCT CONTROL SECTION

11805 SW 26 Street, Room 208
Miami, Florida 33175-2474

T (786) 315-2590 F (786) 315-2599

www.miamidade.gov/economy

NOTICE OF ACCEPTANCE (NOA)

Westlake Royal Roofing LLC.
7575 Irvine Center Drive, Suite 100
Irvine, CA. 92618

SCOPE:

This NOA is being issued under the applicable rules and regulations governing the use of construction materials. The documentation submitted has been reviewed and accepted by Miami-Dade County RER - Product Control Section to be used in Miami Dade County and other areas where allowed by the Authority Having Jurisdiction (AHJ).

This NOA shall not be valid after the expiration date stated below. The Miami-Dade County Product Control Section (In Miami Dade County) and/or the AHJ (in areas other than Miami Dade County) reserve the right to have this product or material tested for quality assurance purposes. If this product or material fails to perform in the accepted manner, the manufacturer will incur the expense of such testing and the AHJ may immediately revoke, modify, or suspend the use of such product or material within their jurisdiction. RER reserves the right to revoke this acceptance, if it is determined by Miami-Dade County Product Control Section that this product or material fails to meet the requirements of the applicable building code.

This product is approved as described herein, and has been designed to comply with the Florida Building Code including the High Velocity Hurricane Zone of the Florida Building Code.

DESCRIPTION: Mission Clay Tile

LABELING: Each unit shall bear a permanent label with the manufacturer's name or logo, city, state and following statement: "Miami-Dade County Product Control Approved", unless otherwise noted herein.

RENEWAL of this NOA shall be considered after a renewal application has been filed and there has been no change in the applicable building code negatively affecting the performance of this product.

TERMINATION of this NOA will occur after the expiration date or if there has been a revision or change in the materials, use, and/or manufacture of the product or process. Misuse of this NOA as an endorsement of any product, for sales, advertising or any other purposes shall automatically terminate this NOA. Failure to comply with any section of this NOA shall be cause for termination and removal of NOA.

ADVERTISEMENT: The NOA number preceded by the words Miami-Dade County, Florida, and followed by the expiration date may be displayed in advertising literature. If any portion of the NOA is displayed, then it shall be done in its entirety.

INSPECTION: A copy of this entire NOA shall be provided to the user by the manufacturer or its distributors and shall be available for inspection at the job site at the request of the Building Official.

This NOA revises NOA# 23-0222.11 and consists of pages 1 through 5.
The submitted documentation was reviewed by Alex Tigera.

03/26/26



NOA No.: 26-0205.01
Expiration Date: 03/06/28
Approval Date: 03/26/26
Page 1 of 5

ROOFING ASSEMBLY APPROVAL

Category: Roofing
Sub Category: Roofing Tiles
Material: Clay

1. SCOPE

This approves a new roofing system using “Mission Clay Tile” as manufactured by Westlake Royal Roofing LLC in Corona, CA and described in Section 2 of this Notice of Acceptance. For locations where the pressure requirements, as determined by applicable Building Code does not exceed the design pressure values obtained by calculations in compliance with RAS 127 using the values listed in section 4 herein. The attachment calculations shall be done as a moment based system.

2. PRODUCT DESCRIPTION

	<u>Dimensions</u>	<u>Test Specifications</u>	<u>Product Description</u>
Mission Clay Tile	L = 18” W = 8.5”	ASTM C 1167 Type I Grade 2	High profile, two-piece, clay roof tile. For mortar set or adhesive set applications
Trim Pieces	l = varies w = varies varying thickness	TAS 112	Accessory trim, concrete roof pieces for use at hips, rakes, ridges and valley terminations. Manufactured for each tile profile.

2.1 MANUFACTURING LOCATION

2.1.1. Corona, CA.

2.2 EVIDENCE SUBMITTED:

<u>Test Agency</u>	<u>Test Identifier</u>	<u>Test Name/Report</u>	<u>Date</u>
American Test Lab of South Florida	RT0121.01-26	ASTM C 1167	01/28/26
The Center for Applied Engineering, Inc.	94-083	Static Uplift Testing PA 101 (Adhesive Set)	April 1994
	257869-1	Static Uplift Testing PA 101 (Mortar Set)	Jan. 1997
Redland Technologies	P0647-01	Wind Tunnel Testing PA 108 (Mortar Set)	Aug. 1994
Walker Engineering, Inc.	Calculations	Aerodynamic Multiplier	April 2003
	Evaluation Calculations	25-7183	March 1995
	Evaluation Calculations	25-7094	February 1996
	Evaluation Calculations	25-7496	April 1996
	Evaluation Calculations	25-7584 25-7804b-8 25-7804-4 & 5 25-7848-6	December 1996



NOA No.: 26-0205.01
 Expiration Date: 03/06/28
 Approval Date: 03/26/26
 Page 2 of 5

3. LIMITATIONS

- 3.1 Fire classification is not part of this acceptance.
- 3.2 For mortar or adhesive set tile applications, a static field uplift test shall be performed in accordance with TAS 106.
- 3.3 Applicant shall retain the services of a Miami-Dade County Certified Laboratory to perform quarterly test in accordance with TAS 112, appendix 'A'. Such testing shall be submitted to the Building Code Compliance Office for review.
- 3.4 Minimum underlayment shall be in compliance with the applicable Roofing Applications Standards listed section 4.1 herein.
- 3.5 30/90 hot mopped underlayment applications may be installed perpendicular to the roof slope unless stated otherwise by the underlayment material manufacturers published literature.
- 3.6 This acceptance is for wood deck applications. Minimum deck requirements shall be in compliance with applicable building code.

4. INSTALLATION

- 4.1 Mission Clay Tile and its components shall be installed in strict compliance with Roofing Application Standard RAS 120.
- 4.2 Data For Attachment Calculations

Table 1: Average Weight (W) and Dimensions (l x w)			
Tile Profile	Weight-W (lbf)	Length-l (ft)	Width-w (ft)
Mission Clay Tile	5.9	1.5	0.708

Table 2: Aerodynamic Multipliers - λ (ft ³)	
Tile Profile	λ (ft ³) Direct Deck Application
Mission Clay Tile	0.249

Table 3: Restoring Moments due to Gravity - M_g (ft-lbf)					
Tile Profile	3":12"	4":12"	5":12"	6":12"	7":12" or greater
Mission Clay Tile	4.10	4.02	3.92	3.81	3.69



**Table 7: Attachment Resistance Expressed as a Moment - M_r (ft-lbf)
for Single Patty Adhesive¹ Set Systems**

Tile Profile	Tile Application	Minimum Attachment Resistance
Mission Clay Tile	ICP Adhesives Polyset® AH-160	177 (Clay tile) ¹
	TILE BOND™ Roof Tile Adhesive	115 (Clay tile) ²

- 1 See foam adhesive manufacturer's component approval for installation requirements
- 2 Place 23 grams per pan and 23 grams per cap of Polyset® AH-160
- 3 Place 11.8 grams per pan and 11.6 grams per cap of TILE BOND™ Roof Tile Adhesive.

**Table 8: Attachment Resistance Expressed as a Moment - M_r (ft-lbf)
for Mortar Set Systems**

Tile Profile	Tile Application	Attachment Resistance
Mission Clay Tile	Mortar Set	24.5 ⁴
		213.8 ⁵

- 4 Bermuda Roof TileTite mortar.
- 5 Quickcrete Roof Tile Mortar # 1140.

5. LABELING

All tiles shall bear the imprint or identifiable marking of the manufacturer's name or logo, or following statement: "Miami-Dade County Product Control Approved".

US Tile

**LABEL FOR MISSION CLAY TILE (CORONA, CALIFORNIA PLANT)
(LOCATED ON THE UNDERSIDE OF TILE)**

6. BUILDING PERMIT REQUIREMENTS

- 6.1 Application for building permit shall be accompanied by copies of the following:
 - 6.1.1 This Notice of Acceptance.
 - 6.1.2 Any other documents required by the Building Official or applicable building code in order to properly evaluate the installation of this system.



PROFILE DRAWINGS

MISSION TWO-PIECE ROOF TILE

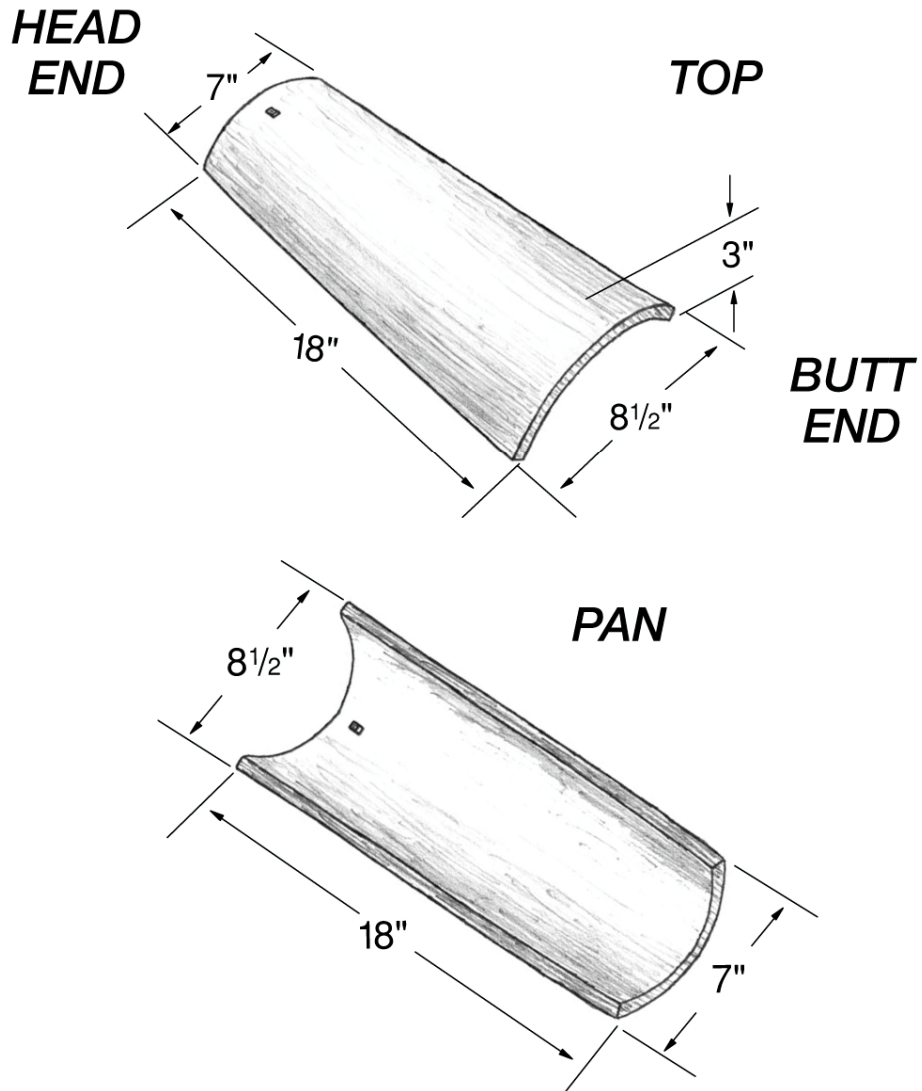

END OF THIS ACCEPTANCE

