



MIAMI-DADE COUNTY, FLORIDA
PRODUCT CONTROL SECTION
 11805 SW 26 Street, Room 208
 Miami, Florida 33175-2474
 T (786) 315-2590 F (786) 315-2599
www.miamidade.gov/economy

DEPARTMENT OF REGULATORY AND ECONOMIC RESOURCES (RER)
 BOARD AND CODE ADMINISTRATION DIVISION
NOTICE OF ACCEPTANCE (NOA)

Miami Wall Systems, Inc.
701 West 25 Street
Hialeah, FL 33010

SCOPE:

This NOA is being issued under the applicable rules and regulations governing the use of construction materials. The documentation submitted has been reviewed and accepted by Miami-Dade County RER - Product Control Section to be used in Miami Dade County and other areas where allowed by the Authority Having Jurisdiction (AHJ).

This NOA shall not be valid after the expiration date stated below. The Miami-Dade County Product Control Section (In Miami-Dade County) and/ or the AHJ (in areas other than Miami-Dade County) reserve the right to have this product or material tested for quality assurance purposes. If this product or material fails to perform in the accepted manner, the manufacturer will incur the expense of such testing and the AHJ may immediately revoke, modify, or suspend the use of such product or material within their jurisdiction. RER reserves the right to revoke this acceptance, if it is determined by Miami-Dade County Product Control Section that this product or material fails to meet the requirements of the applicable building code.

This product is approved as described herein and has been designed to comply with the Florida Building Code, including the High Velocity Hurricane Zone.

DESCRIPTION: Series "122" Aluminum Single Hung Window – L.M.I.

APPROVAL DOCUMENT: Drawing No. 122-SH-LM, titled "Single Hung Window 122 Series (LMI)", sheets 1 through 8 of 8, dated 9/4/08, with revision #3 dated 03/10/26, prepared by manufacturer, signed and sealed by Jorge E. Valdes, P.E., bearing the Miami-Dade County Product Control Revision stamp with the Notice of Acceptance number and expiration date by the Miami-Dade County Product Control Section.

MISSILE IMPACT RATING: Large and Small Missile Impact Resistant

LABELING: Each unit shall bear a permanent label with the manufacturer's name or logo, city, state, model/series, and following statement: "Miami-Dade County Product Control Approved", unless otherwise noted herein.

RENEWAL of this NOA shall be considered after a renewal application has been filed and there has been no change in the applicable building code negatively affecting the performance of this product.

TERMINATION of this NOA will occur after the expiration date or if there has been a revision or change in the materials, use, and/ or manufacture of the product or process. Misuse of this NOA as an endorsement of any product, for sales, advertising or any other purposes shall automatically terminate this NOA. Failure to comply with any section of this NOA shall be cause for termination and removal of NOA.

ADVERTISEMENT: The NOA number preceded by the words Miami-Dade County, Florida, and followed by the expiration date may be displayed in advertising literature. If any portion of the NOA is displayed, then it shall be done in its entirety.

INSPECTION: A copy of this entire NOA shall be provided to the user by the manufacturer or its distributors and shall be available for inspection at the job site at the request of the Building Official.

This NOA **revises and renews** NOA No. 21-0628.11 and consists of this page 1 and evidence pages E-1, E-2, E-3 and E-4, as well as approval document mentioned above.

The submitted documentation was reviewed by **Manuel Perez, P.E.**

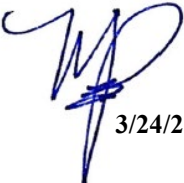

 3/24/26

NOA No. 26-0311.03
 Expiration Date: August 15, 2029
 Approval Date: April 02, 2026
 Page 1

NOTICE OF ACCEPTANCE: EVIDENCE SUBMITTED

1. EVIDENCE SUBMITTED UNDER PREVIOUS NOA's

A. DRAWINGS

1. Manufacturer's die drawings and sections.
(Submitted under NOA No. 04-1122.06)
2. Drawing No. **122-SH-LM**, titled "Single Hung Window 122 Series (LMI)", sheets 1 through 8 of 8, dated 09/04/08, with revision #2 dated 03/16/21, prepared by manufacturer, signed and sealed by Jorge E. Valdes, P.E.
(Submitted under NOA No. 21-0628.11)

B. TESTS

1. Test report on: 1) Air Infiltration Test, per FBC, TAS 202-94
2) Uniform Static Air Pressure Test, Loading per FBC TAS 202-94
3) Water Resistance Test, per FBC, TAS 202-94
4) Large Missile Impact Test per FBC, TAS 201-94
5) Cyclic Wind Pressure Loading per FBC, TAS 203-94
6) Forced Entry Test, per FBC 2411 3.2.1, TAS 202-94
along with marked-up drawings and installation diagram of a series 122 single hung muller to fixed window, prepared by Fenestration Testing Laboratory, Inc., Test Report No. **FTL-12615**, dated June 16, 2021, signed and sealed by Idalmis Ortega, P.E.
(Submitted under NOA No. 21-0628.11)
2. Test report on: 1) Air Infiltration Test, per FBC, TAS 202-94
2) Uniform Static Air Pressure Test, Loading per FBC TAS 202-94
3) Water Resistance Test, per FBC, TAS 202-94
4) Large Missile Impact Test per FBC, TAS 201-94
5) Cyclic Wind Pressure Loading per FBC, TAS 203-94
6) Forced Entry Test, per FBC 2411 3.2.1, TAS 202-94
along with marked-up drawings and installation diagram of an aluminum single hung window, prepared by Fenestration Testing Laboratory, Inc., Test Report No. **FTL-3385**, dated May 03, 2002, signed and sealed by Luis Antonio Figueredo, P.E.
(Submitted under NOA No. 04-1122.06)
3. Test reports on: 1) Air Infiltration Test, per FBC, TAS 202-94
2) Uniform Static Air Pressure Test, Loading per FBC TAS 202-94
3) Water Resistance Test, per FBC, TAS 202-94
4) Large Missile Impact Test per FBC, TAS 201-94
5) Cyclic Wind Pressure Loading per FBC, TAS 203-94
6) Forced Entry Test, per FBC 2411 3.2.1, TAS 202-94
along with marked-up drawings and installation diagram of aluminum single hung muller windows, prepared by Fenestration Testing Laboratory, Inc., Test Report No. **FTL-3386**, dated May 01, 2002, signed and sealed by Luis Antonio Figueredo, P.E.
(Submitted under NOA No. 04-1122.06)

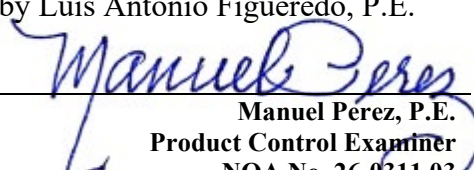
Manuel Perez, P.E.
Product Control Examiner
NOA No. 26-0311.03
Expiration Date: August 15, 2029
Approval Date: April 02, 2026

NOTICE OF ACCEPTANCE: EVIDENCE SUBMITTED

1. EVIDENCE SUBMITTED UNDER PREVIOUS NOA's (CONTINUED)

B. TESTS (CONTINUED)

4. Test reports on: 1) Air Infiltration Test, per FBC, TAS 202-94
2) Uniform Static Air Pressure Test, Loading per FBC TAS 202-94
3) Water Resistance Test, per FBC, TAS 202-94
4) Large Missile Impact Test per FBC, TAS 201-94
5) Cyclic Wind Pressure Loading per FBC, TAS 203-94
6) Forced Entry Test, per FBC 2411 3.2.1, TAS 202-94

along with marked-up drawings and installation diagram of an aluminum equal leg aluminum fixed frame window, prepared by Fenestration Testing Laboratory, Inc., Test Report No. **FTL-4091**, dated February 20, 2004, signed and sealed by Edmundo Largaespada, P.E. (*For Reference only*)

(Submitted under NOA No. 04-1122.06)

5. Test reports on: 1) Air Infiltration Test, per FBC, TAS 202-94
2) Uniform Static Air Pressure Test, Loading per FBC TAS 202-94
3) Water Resistance Test, per FBC, TAS 202-94
4) Large Missile Impact Test per FBC, TAS 201-94
5) Cyclic Wind Pressure Loading per FBC, TAS 203-94
6) Forced Entry Test, per FBC 2411 3.2.1, TAS 202-94

along with marked-up drawings and installation diagram of an aluminum equal leg fixed frame windows mullied together, prepared by Fenestration Testing Laboratory, Inc., Test Report No. **FTL-5595**, dated 06/06/08, signed and sealed by Carlos Rionda, P.E.

(For Reference only)

(Submitted under NOA No. 08-0512.15)

C. CALCULATIONS

1. Anchor verification calculations and structural analysis, complying with **FBC 7th Edition (2020)**, dated 08/19/21, prepared by Miami Wall Systems, Inc., signed and sealed by Jorge E. Valdes, P.E.

(Submitted under NOA No. 21-0628.11)

2. Glazing complies with **ASTM E1300-16**

D. QUALITY ASSURANCE

1. Miami-Dade Department of Regulatory and Economic Resources (RER)

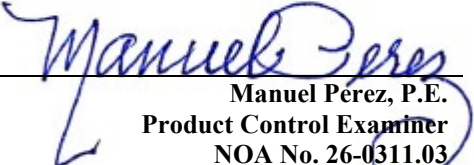
Manuel Perez, P.E.
Product Control Examiner
NOA No. 26-0311.03
Expiration Date: August 15, 2029
Approval Date: April 02, 2026

Miami Wall Systems, Inc.

NOTICE OF ACCEPTANCE: EVIDENCE SUBMITTED

1. EVIDENCE SUBMITTED UNDER PREVIOUS NOA's (CONTINUED)

E. MATERIAL CERTIFICATIONS

1. Notice of Acceptance No. **20-0915.22** issued to **Kuraray America, Inc.** for their "Trosifol® Ultraclear, Clear and Color PVB Glass Interlayers" dated 11/19/20, expiring on 07/08/24.
2. Notice of Acceptance No. **20-0915.19** issued to **Kuraray America, Inc.** for their "SentryGlas® (Clear and White) Glass Interlayers" dated 11/19/20, expiring on 07/04/23.

F. STATEMENTS

1. Statement letters of conformance, complying with **FBC 7th Edition (2020)**, dated August 17, 2021, prepared by manufacturer, signed and sealed by Jorge E. Valdes, P.E.
(Submitted under NOA No. 21-0628.11)
2. Statement letters of no financial interest, dated August 17, 2021, prepared by manufacturer, signed and sealed by Jorge E. Valdes, P.E.
(Submitted under NOA No. 21-0628.11)
3. Proposal No. **21-0333** issued by the Product Control Section, dated April 30, 2021, signed by Manuel Perez, P.E.
(Submitted under NOA No. 21-0628.11)

G. OTHERS

1. Notice of Acceptance No. **19-0409.04**, issued to Miami Wall Systems, Inc. for their Series "122" Aluminum Single Hung Window - L.M.I., approved on 08/15/19 and expiring on 08/15/24.

Manuel Perez, P.E.
Product Control Examiner
NOA No. 26-0311.03
Expiration Date: August 15, 2029
Approval Date: April 02, 2026

Miami Wall Systems, Inc.

NOTICE OF ACCEPTANCE: EVIDENCE SUBMITTED

2. NEW EVIDENCE SUBMITTED

A. DRAWINGS

1. Drawing No. **122-SH-LM**, titled “Single Hung Window 122 Series (LMI)”, sheets 1 through 8 of 8, dated 09/04/08, with revision #3 dated 03/10/26, prepared by manufacturer, signed and sealed by Jorge E. Valdes, P.E.

B. TESTS

1. None.

C. CALCULATIONS

1. None.

D. QUALITY ASSURANCE

1. Miami-Dade Department of Regulatory and Economic Resources (RER)

E. MATERIAL CERTIFICATIONS

1. Notice of Acceptance No. **24-0205.08** issued to **Kuraray America, Inc.** for their “**Trosifol® Ultraclear, Clear and Color PVB Glass Interlayers**” dated 03/21/24, expiring on 07/08/29.
2. Notice of Acceptance No. **23-0717.30** issued to **Kuraray America, Inc.** for their “**SentryGlas® (Clear and White) Glass Interlayers**” dated 08/31/23, expiring on 07/04/28.

F. STATEMENTS

1. Statement letters of conformance, complying with **FBC 8th Edition (2023)**, dated March 10, 2026, prepared by manufacturer, signed and sealed by Jorge E. Valdes, P.E.
2. Statement letters of no financial interest, dated March 24, 2026, prepared by manufacturer, signed and sealed by Jorge E. Valdes, P.E.

G. OTHERS

1. Notice of Acceptance No. **21-0628.11**, issued to Miami Wall Systems, Inc. for their Series “122” Aluminum Single Hung Window - L.M.I., approved on 09/09/21 and expiring on 08/15/24.

Manuel Perez, P.E.
Product Control Examiner
NOA No. 26-0311.03
Expiration Date: August 15, 2029
Approval Date: April 02, 2026

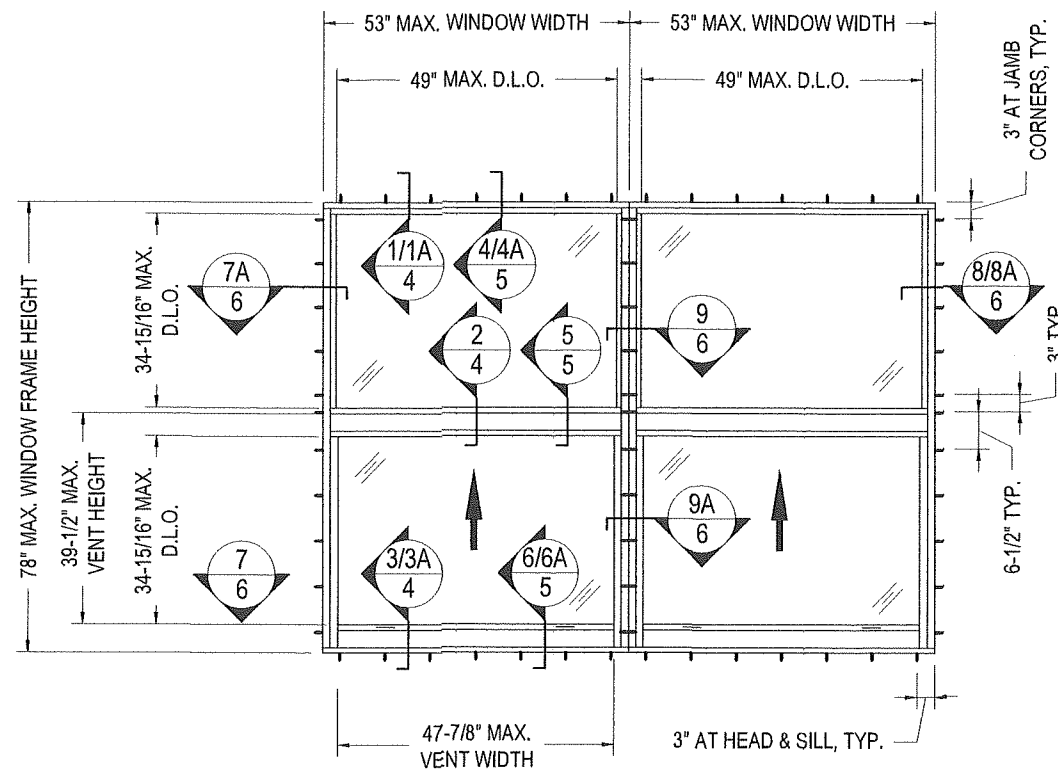
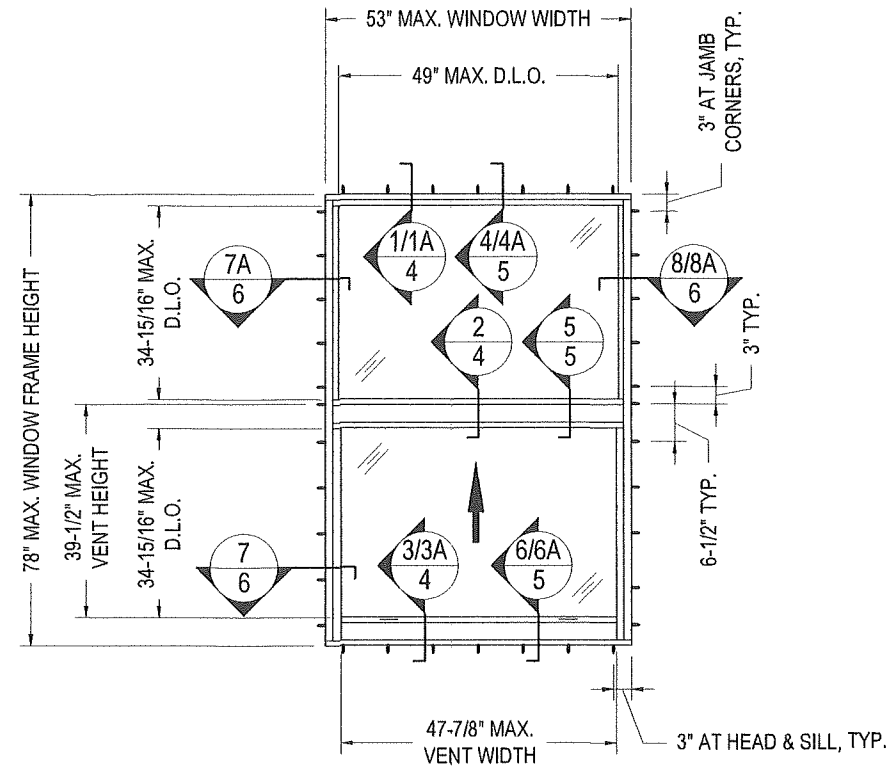
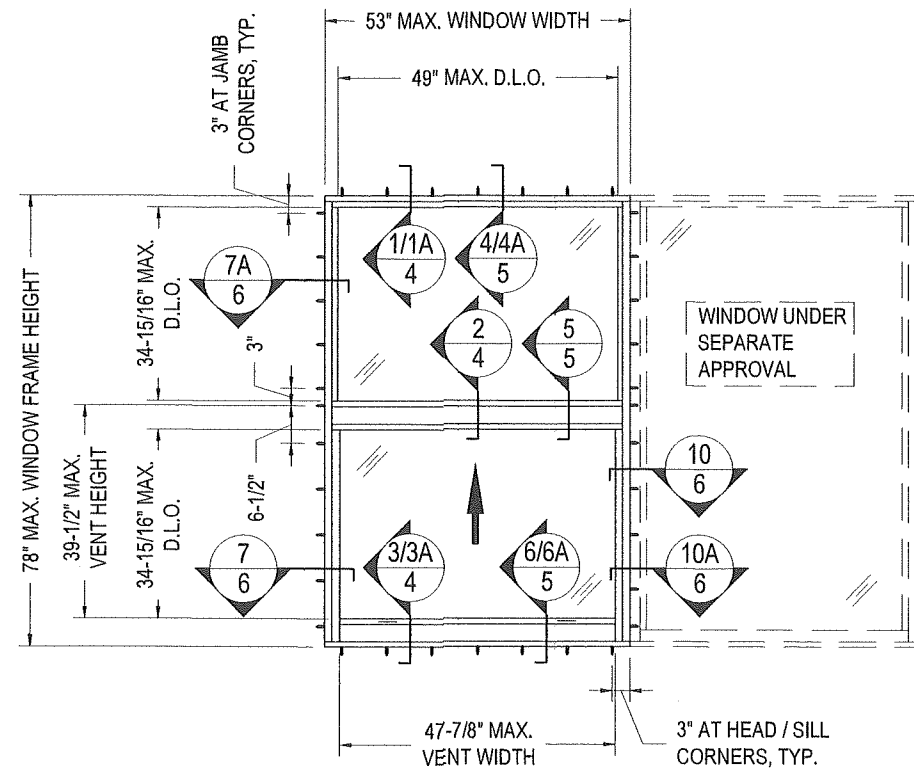

THESE WINDOWS ARE RATED LARGE AND SMALL MISSILE IMPACT. SHUTTERS ARE NOT REQUIRED

PRODUCT REVISED
 As complying with the Florida Building Code
NOA-No. 26-0311.03
Expiration Date: 08/15/2029
 By: *Manuel Perez*
 Miami-Dade Product Control

SERIES 122 ALUMINUM SINGLE HUNG WINDOWS

GENERAL NOTES:

1. THIS PRODUCT HAS BEEN DESIGNED AND TESTED IN ACCORDANCE WITH THE 2023 FLORIDA BUILDING CODE 8TH EDITION (HIGH VELOCITY HURRICANE ZONE)
2. WOOD BUCKS MUST BE ENGINEERED TO TAKE THE WIND LOADS IMPOSED BY WINDOWS AND TO BE REVIEWED BY BUILDING OFFICIAL.
3. ALL INSTALLATION FASTENERS HOLES MUST BE IN-FACTORY PUNCHED FOR 1/4" DIAMETER FLAT HEAD SCREWS.
4. EQUAL AND UNEQUAL LEG FRAME CONDITIONS INCLUDED.
5. LOCK OPTIONS INCLUDE CAM LOCKS OR SPRING LOCKS OR BOTH.
6. UN-CLIPPED VERTICAL MULLION APPLICATION SHALL BE LIMITED TO APPROVED WINDOW DIMENSIONS, SEE MULLION LOAD CAPACITY CHART 2, SHEET 3 OF 8.
7. USE CLUSTER OF FASTENERS AT SILL AND HEAD WHERE UNCLIPPED VERTICAL MULLIONS OCCUR ONLY (SEE DETAIL "A", SHEET 3 OF 8)

INSTRUCTIONS:

- STEP 1** - DETERMINE DESIGN WIND LOAD REQUIREMENT BASED ON WIND VELOCITY, BUILDING HEIGHT, WIND ZONE USING APPLICABLE **ASCE 7** STANDARD.
- STEP 2** - SEE CHART 1 ON SHEET 2 FOR DESIGN LOAD CAPACITY OF DESIRED GLASS SIZE.
- STEP 3** - IF WINDOWS ARE TO BE MULLED TOGETHER, CHECK MULLION CAPACITY FOR A GIVEN SPACING AND HEIGHT USING CHART 2 ON SHEET 3 OF 8. THE CAPACITY SHOULD EXCEED THE DESIGN LOAD.
- STEP 4** - THE LOWEST VALUE RESULTING FROM STEP 2 AND 3 SHALL APPLY TO ENTIRE SYSTEM.

| INSTALLATION HOLES SPACING CHART | | | |
|----------------------------------|----------|----------|-----------|
| DESIGN PRESSURE | ± 75 PSF | ± 90 PSF | ± 120 PSF |
| HEAD / SILL | 15-3/4" | 11-3/4" | 9-1/4" |
| JAMBS | 17-3/8" | 9" | 7-1/4" |

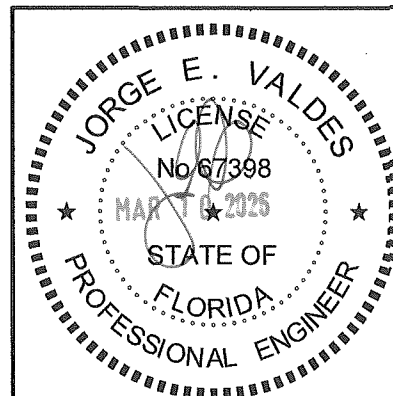

Miami Wall Systems, Inc.
 701 West 25th Street
 Hialeah, Florida. 33010
 Phone: (305) 888-2300 Fax: (305) 888-3058

SINGLE HUNG WINDOW 122 SERIES (LMT)
 TYPICAL ELEVATIONS
 GENERAL NOTES

| NO. | DATE | REVISION |
|-----|-----------|--------------------|
| 1 | 5/29/2019 | UPDATE TO 2017 FBC |
| 2 | 3/16/2021 | UPDATE TO 2020 FBC |
| 3 | 3/10/2026 | UPDATE TO 2023 FBC |

DATE: 9/4/2008
 SCALE: 3/8" = 1'-0"
 DWG. BY: L.R.A.
 CHK. BY: JV
 DWG NO.: 122-SH-LM
 SHEET 1 OF 8

CHART 1

| GLASS DESIGN LOAD CAPACITY - PSF | | | | | | | |
|----------------------------------|------------|-----------------|--------------|-----------------|--------------|-----------------|--------------|
| WINDOW DIMENSION | | GLASS TYPE GL-1 | | GLASS TYPE GL-2 | | GLASS TYPE GL-3 | |
| WIDTH (W) | HEIGHT (H) | EXTERIOR (+) | INTERIOR (-) | EXTERIOR (+) | INTERIOR (-) | EXTERIOR (+) | INTERIOR (-) |
| 40 | 64 | 90 | 90 | 120 | 120 | 75 | 75 |
| 44 | | 90 | 90 | 120 | 120 | 75 | 75 |
| 48 | | 90 | 90 | 120 | 120 | - | - |
| 53 | | 90 | 90 | 120 | 120 | - | - |
| 40 | 68 | 90 | 90 | 120 | 120 | 75 | 75 |
| 44 | | 90 | 90 | 120 | 120 | - | - |
| 48 | | 90 | 90 | 120 | 120 | - | - |
| 52 | | 90 | 90 | 120 | 120 | - | - |
| 36 | 72 | 90 | 90 | 120 | 120 | 75 | 75 |
| 40 | | 90 | 90 | 120 | 120 | - | - |
| 44 | | 90 | 90 | 120 | 120 | - | - |
| 48 | | 90 | 90 | 120 | 120 | - | - |
| 53 | 76 | 90 | 90 | 120 | 120 | - | - |
| 36 | | 90 | 90 | 120 | 120 | 75 | 75 |
| 40 | | 90 | 90 | 120 | 120 | - | - |
| 44 | | 90 | 90 | 120 | 120 | - | - |
| 48 | 78 | 90 | 90 | 120 | 120 | - | - |
| 36 | | 90 | 90 | 120 | 120 | 75 | 75 |
| 40 | | 90 | 90 | 120 | 120 | - | - |
| 44 | | 90 | 90 | 120 | 120 | - | - |
| 48 | 82 | 90 | 90 | 120 | 120 | - | - |
| 36 | | 90 | 90 | 120 | 120 | 75 | 75 |
| 40 | | 90 | 90 | 120 | 120 | - | - |
| 44 | | 90 | 90 | 120 | 120 | - | - |

NOTE:

STANDARD SILL AND STANDARD MEETING RAIL OPTIONS ARE LIMITED TO ± 90 PSF
(SEE SHEET 4 OF 8 AND 5 OF 8)

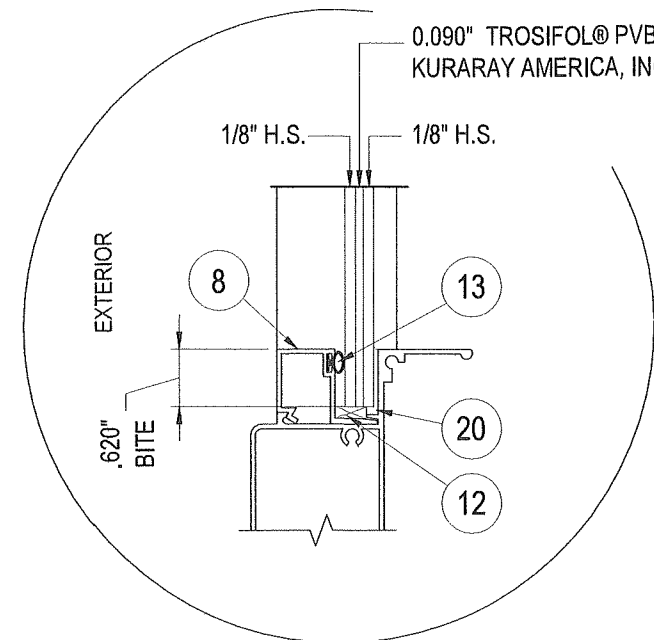

GLASS TYPE GL-1
5/16" OVERALL THICKNESS LAMINATED GLASS

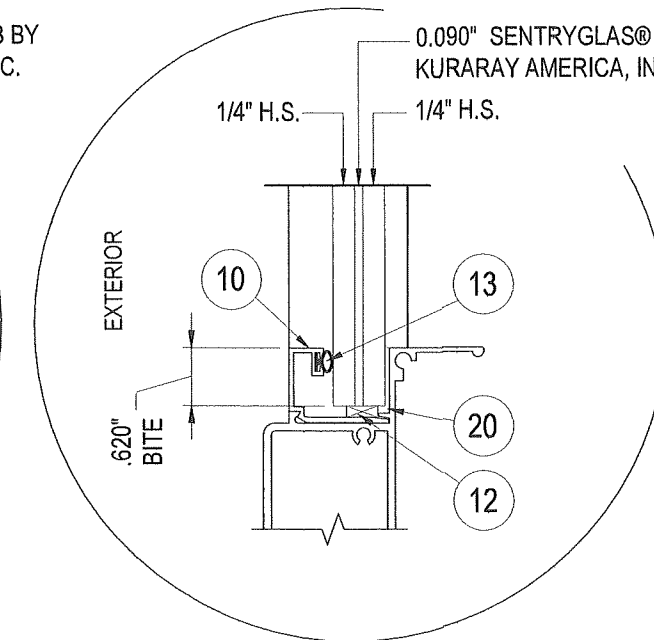

GLASS TYPE GL-2
9/16" OVERALL THICKNESS LAMINATED GLASS

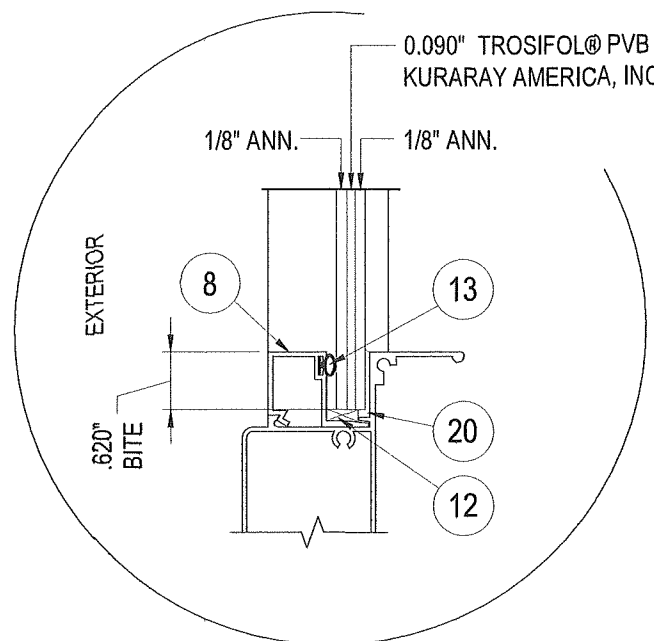

GLASS TYPE GL-3
5/16" OVERALL THICKNESS LAMINATED GLASS

GLASS OPTIONS

SCALE 1:2

PRODUCT REVISED
As complying with the Florida Building Code
NOA-No. **26-0311.03**
Expiration Date: **08/15/2029**
By: *Manuel Perez*
Miami-Dade Product Control

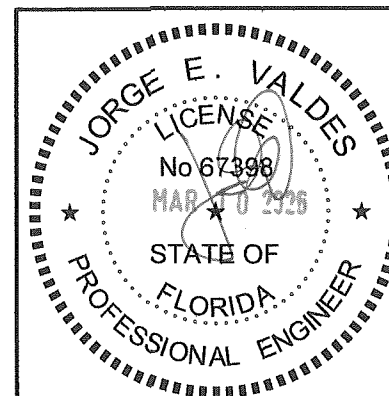

Miami Wall Systems, Inc.
701 West 25th Street
Hialeah, Florida. 33010
Phone: (305) 888-2300 Fax: (305) 888-3058

SINGLE HUNG WINDOW 122 SERIES (LMI)
GLASS DESIGN LOAD CHART
GLASS OPTIONS

| NO. | DATE | REVISION |
|-----|-----------|--------------------|
| 1 | 5/20/2019 | UPDATE TO 2017 FBC |
| 2 | 3/13/2021 | UPDATE TO 2020 FBC |
| 3 | 3/10/2026 | UPDATE TO 2023 FBC |
| | | |
| | | |

DATE: 9/4/2008
SCALE: AS NOTED
DWG. BY: L.R.A.
CHK. BY: JV
DWG NO.: 122-SH-LM
SHEET 2 OF 8

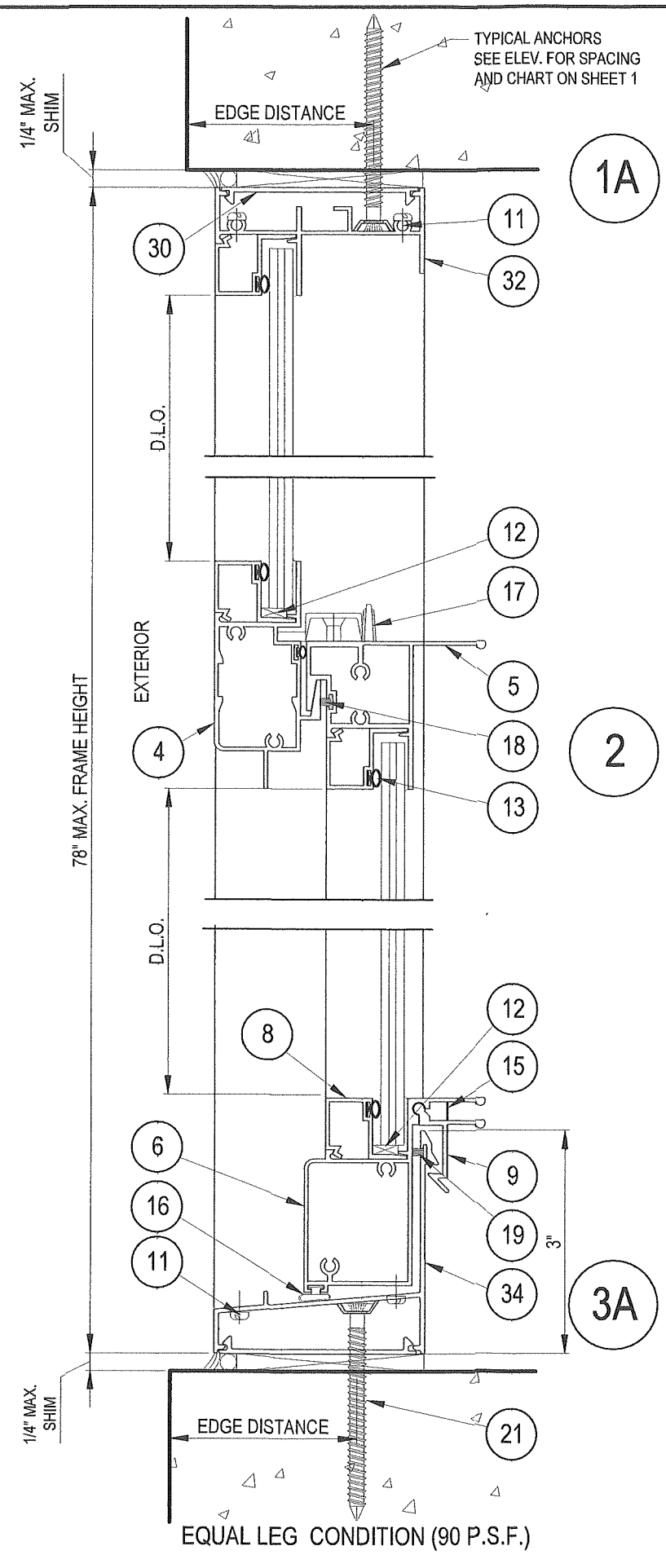
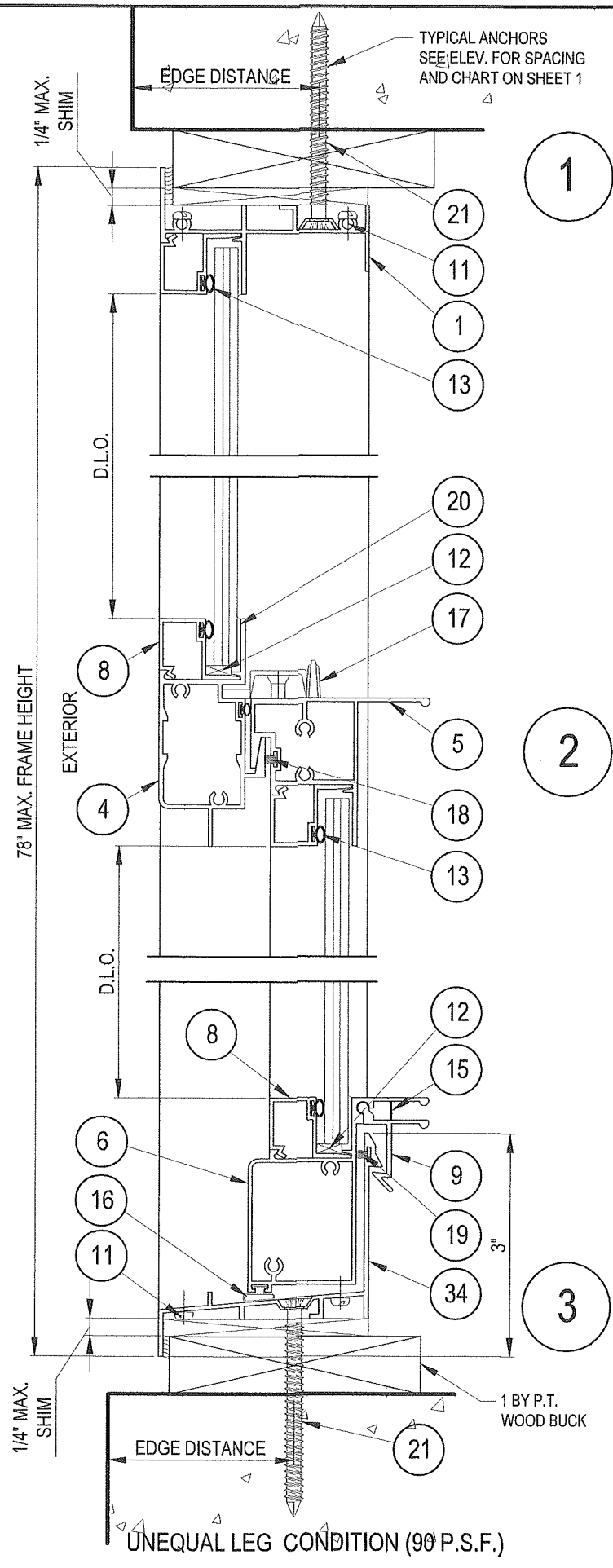

WOOD BUCKS & METAL STRUCTURES NOT BY MWS MUST SUSTAIN LOADS IMPOSED BY GLAZING SYSTEM & TRANSFER THEM TO THE BUILDING STRUCTURE.

TYPICAL ANCHORS: SEE ELEV. FOR SPACING AND CHART ON SHEET 1
 1/4" DIA. ULTRACON BY "ELCO" (Fu=177 KS1, Fy=155 KSI)
 INTO 2BY BUCKS OR WOOD STRUCTURES:
 1 1/2" MIN. PENETRATION INTO WOOD (HEAD / SILL / JAMBS).
 THRU 1BY BUCKS INTO CONC. OR BLOCKS:
 1 1/4" MIN. EMBED INTO CONCRETE (HEAD / SILL)
 1 1/4" MIN. EMBED INTO CONCRETE OR BLOCKS (JAMBS)
 DIRECTLY INTO CONC. OR BLOCKS
 1 1/4" MIN. EMBED INTO CONCRETE (HEAD / SILL)
 1 1/4" MIN. EMBED INTO CONCRETE OR BLOCKS (JAMBS)
 1/4" DIA. DRIL-FLEX SELF DRILLING SCREWS BY "ELCO" (GRADE 5 CRS)
 INTO MIAMI-DADE COUNTY APPROVED MULLIONS OR INTO METAL STRUCTURES (HEAD / SILL / JAMBS) (3) THREADS MIN. TO EXTEND BEYOND METAL THICKNESS
 ALUMINUM: 1/8" THK. MIN. (6063-T5 MIN.)
 STEEL: 1/8" THK. MIN. (Fy = 36 KSI MIN.)
 (STEEL IN CONTACT WITH ALUMINUM TO BE PLATED OR PAINTED)
 ANCHOR EDGE DISTANCE
 INTO CONCRETE AT HEAD OR INTO CONCRETE / BLOCKS AT JAMBS = 2 1/2" MIN.
 INTO CONCRETE AT SILL = 2 1/2" MIN.
 INTO WOOD STRUCTURE = 1" MIN.
 INTO METAL STRUCTURE = 3/4" MIN.
 WOOD AT HEAD, SILL OR JAMBS: SG = 0.55 MIN.
 CONCRETE AT HEAD, SILL OR JAMBS: f'c = 3000 PSI MIN.
 C-90 HOLLOW/FILLED BLOCK AT JAMBS: f'm = 2000 PSI MIN.

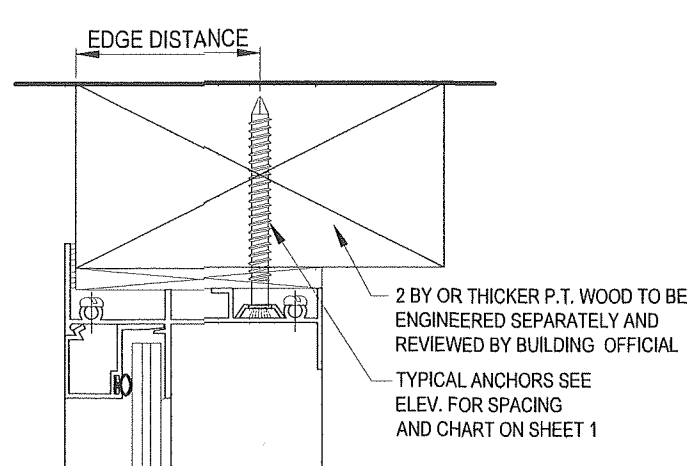

ANCHORAGE OPTION INTO WOOD

PRODUCT REVISED
 As complying with the Florida Building Code
 NOA-No. **26-0311.03**
 Expiration Date: **08/15/2029**
 By: *Manuel Fern*
 Miami-Dade Product Control

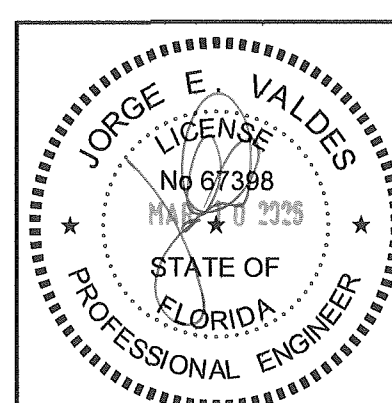

Miami Wall Systems, Inc.
 701 West 25th Street
 Hialeah, Florida, 33010
 Phone: (305) 868-2300 Fax: (305) 868-3058

SINGLE HUNG WINDOW 122 SERIES (LMT)

VERTICAL SECTIONS ANCHOR NOTES

| NO. | DATE | REVISION |
|-----|-----------|--------------------|
| 1 | 5/20/2019 | UPDATE TO 2017 FBC |
| 2 | 3/16/2021 | UPDATE TO 2020 FBC |
| 3 | 3/10/2026 | UPDATE TO 2023 FBC |

DATE: 9/4/2008
 SCALE: 1:2
 DWG. BY: L.R.A.
 CHK. BY: JV
 DWG NO.: 122-SH-LM
 SHEET 4 OF 8

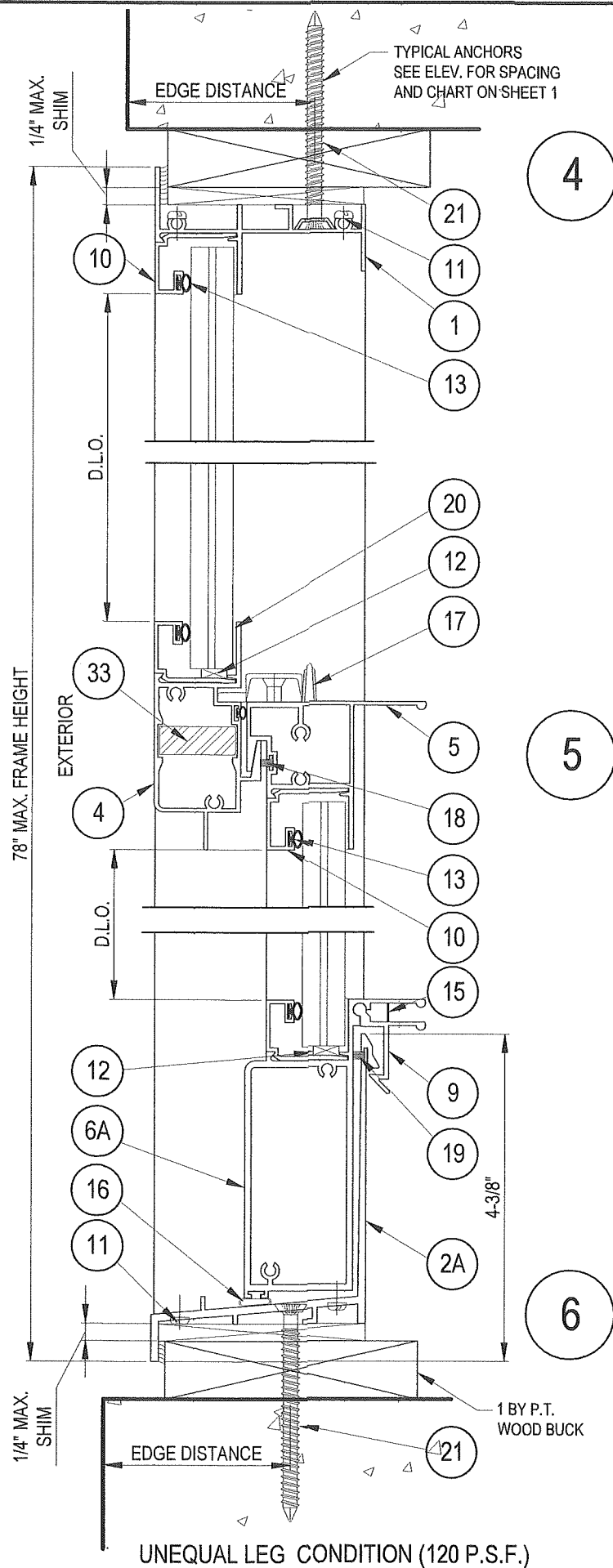

4

5

6

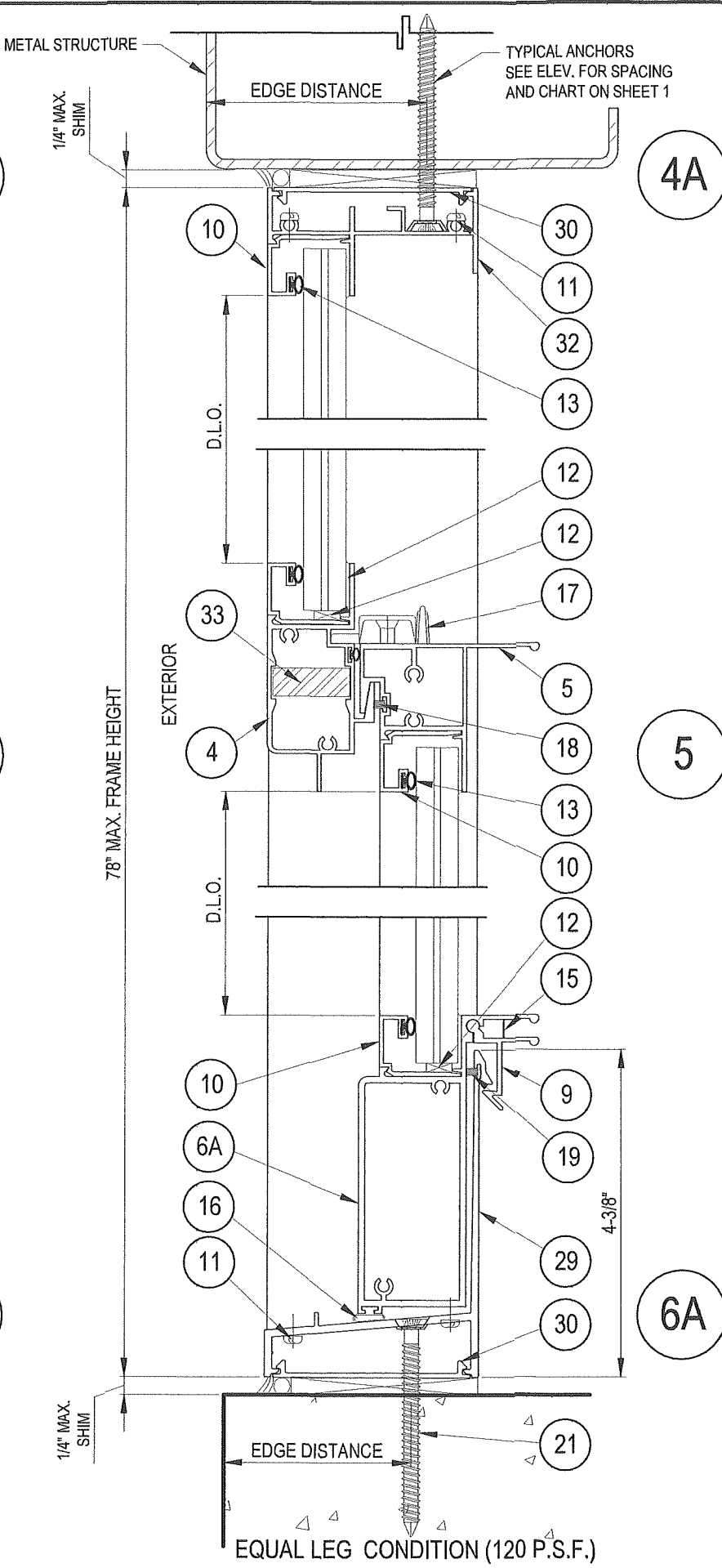

4A

5

6A

WOOD BUCKS & METAL STRUCTURES NOT BY MWS MUST SUSTAIN LOADS IMPOSED BY GLAZING SYSTEM & TRANSFER THEM TO THE BUILDING STRUCTURE.

TYPICAL ANCHORS: SEE ELEV. FOR SPACING AND CHART ON SHEET 1
 1/4" DIA. ULTRACON BY "ELCO" (Fu=177 KSI, Fy=155 KSI)
 INTO 2BY BUCKS OR WOOD STRUCTURES:
 1 1/2" MIN. PENETRATION INTO WOOD (HEAD / SILL / JAMBS).
 THRU 1BY BUCKS INTO CONC. OR BLOCKS:
 1 1/4" MIN. EMBED INTO CONCRETE (HEAD / SILL)
 1 1/4" MIN. EMBED INTO CONCRETE OR BLOCKS (JAMBS)
 DIRECTLY INTO CONC. OR BLOCKS
 1 1/4" MIN. EMBED INTO CONCRETE (HEAD / SILL)
 1 1/4" MIN. EMBED INTO CONCRETE OR BLOCKS (JAMBS)
 1/4" DIA. DRIL-FLEX SELF DRILLING SCREWS BY "ELCO" (GRADE 5 CRS)

INTO MIAMI-DADE COUNTY APPROVED MULLIONS OR INTO METAL STRUCTURES (HEAD / SILL / JAMBS) (3) THREADS MIN. TO EXTEND BEYOND METAL THICKNESS
 ALUMINUM: 1/8" THK. MIN. (6063-T5 MIN.)
 STEEL: 1/8" THK. MIN. (Fy = 36 KSI MIN.)
 (STEEL IN CONTACT WITH ALUMINUM TO BE PLATED OR PAINTED)

ANCHOR EDGE DISTANCE
 INTO CONCRETE AT HEAD OR INTO CONCRETE / BLOCKS AT JAMBS = 2 1/2" MIN.
 INTO CONCRETE AT SILL = 2 1/2" MIN.
 INTO WOOD STRUCTURE = 1" MIN.
 INTO METAL STRUCTURE = 3/4" MIN.

WOOD AT HEAD, SILL OR JAMBS: SG = 0.55 MIN.
 CONCRETE AT HEAD, SILL OR JAMBS: f'c = 3000 PSI MIN.
 C-90 HOLLOW/FILLED BLOCK AT JAMBS: f'm = 2000 PSI MIN.

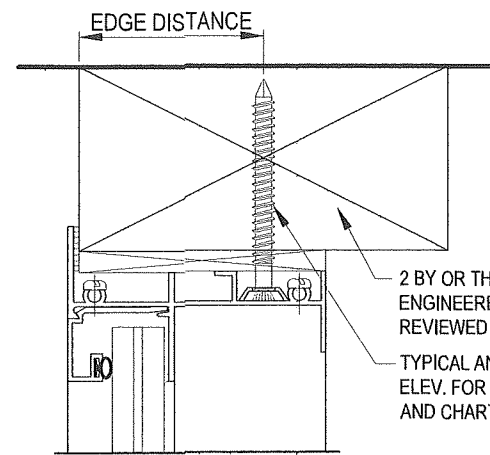

ANCHORAGE OPTION INTO WOOD

PRODUCT REVISED
 As complying with the Florida Building Code
 NOA-No. **26-0311.03**
 Expiration Date: **08/15/2029**
 By: *Manuel Perez*
 Miami-Dade Product Control

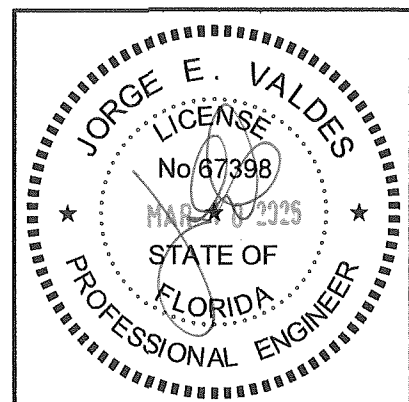

Miami Wall Systems, Inc.
 701 West 25th Street
 Hialeah, Florida. 33010
 Phone: (305) 888-2300 Fax: (305) 888-3058

SINGLE HUNG WINDOW 122 SERIES (LMI)
 VERTICAL SECTIONS
 ANCHOR NOTES

| NO. | DATE | REVISION |
|-----|-----------|--------------------|
| 1 | 5/20/2019 | UPDATE TO 2017 FBC |
| 2 | 3/16/2021 | UPDATE TO 2020 FBC |
| 3 | 3/10/2026 | UPDATE TO 2023 FBC |

DATE: 9/4/2008
 SCALE: 1:2
 DWG. BY: L.R.A.
 CHK. BY: JV
 DWG NO.: 122-SH-LM
 SHEET 5 OF 8

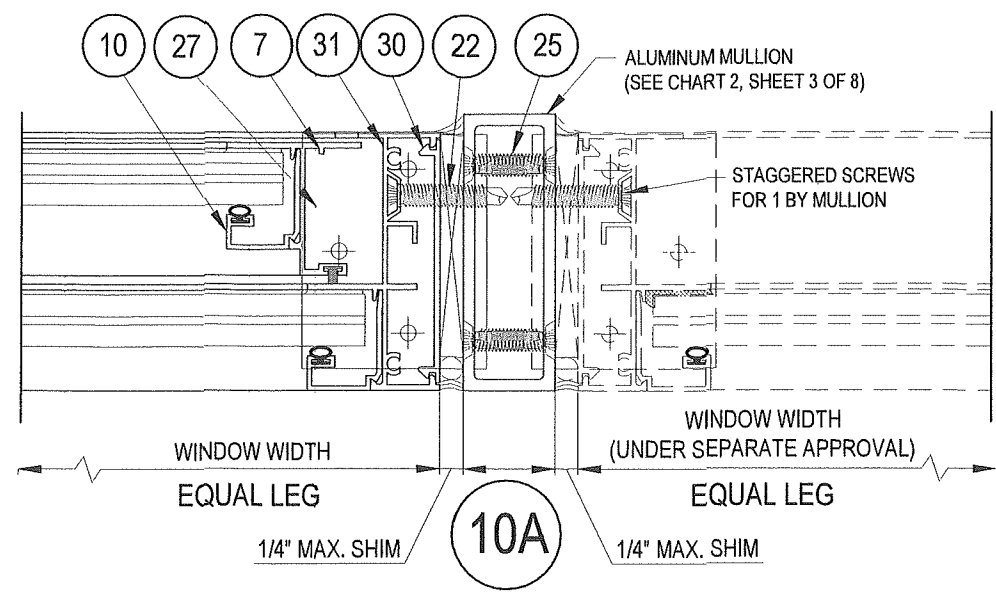
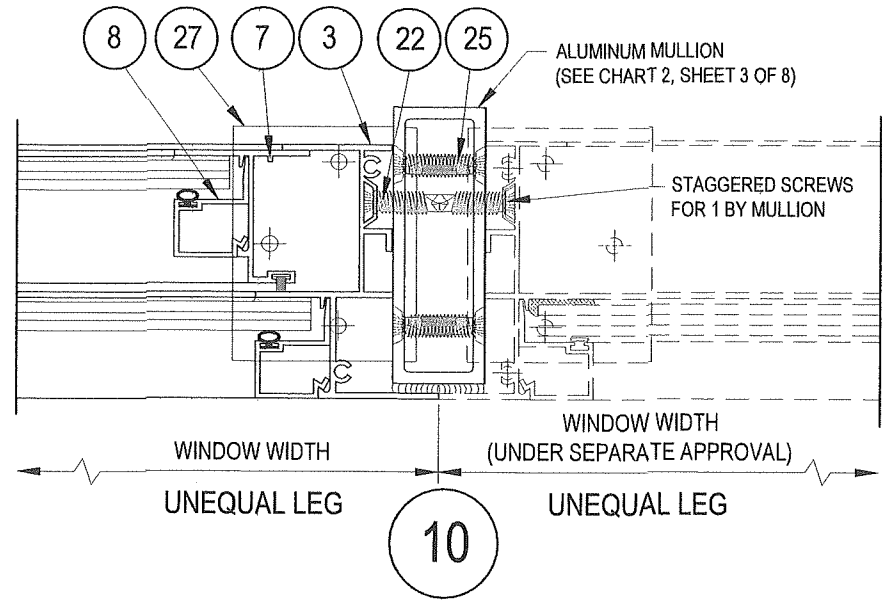
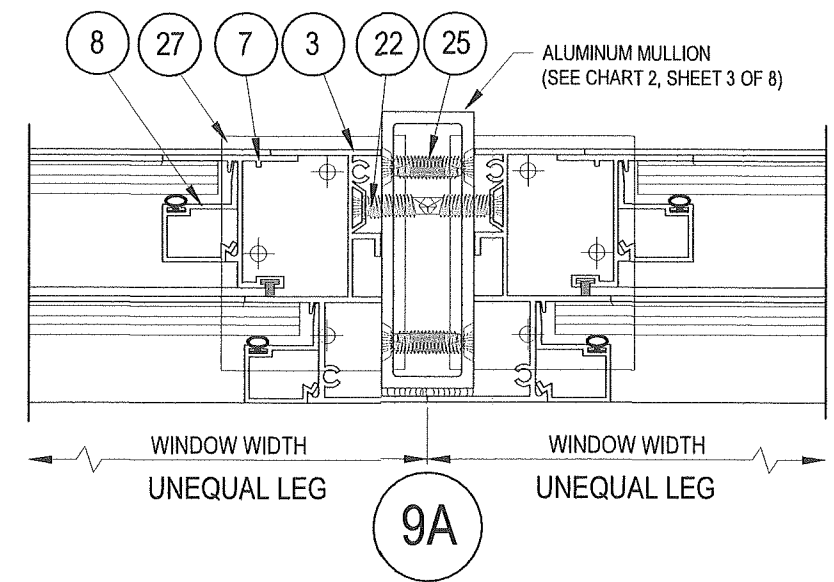
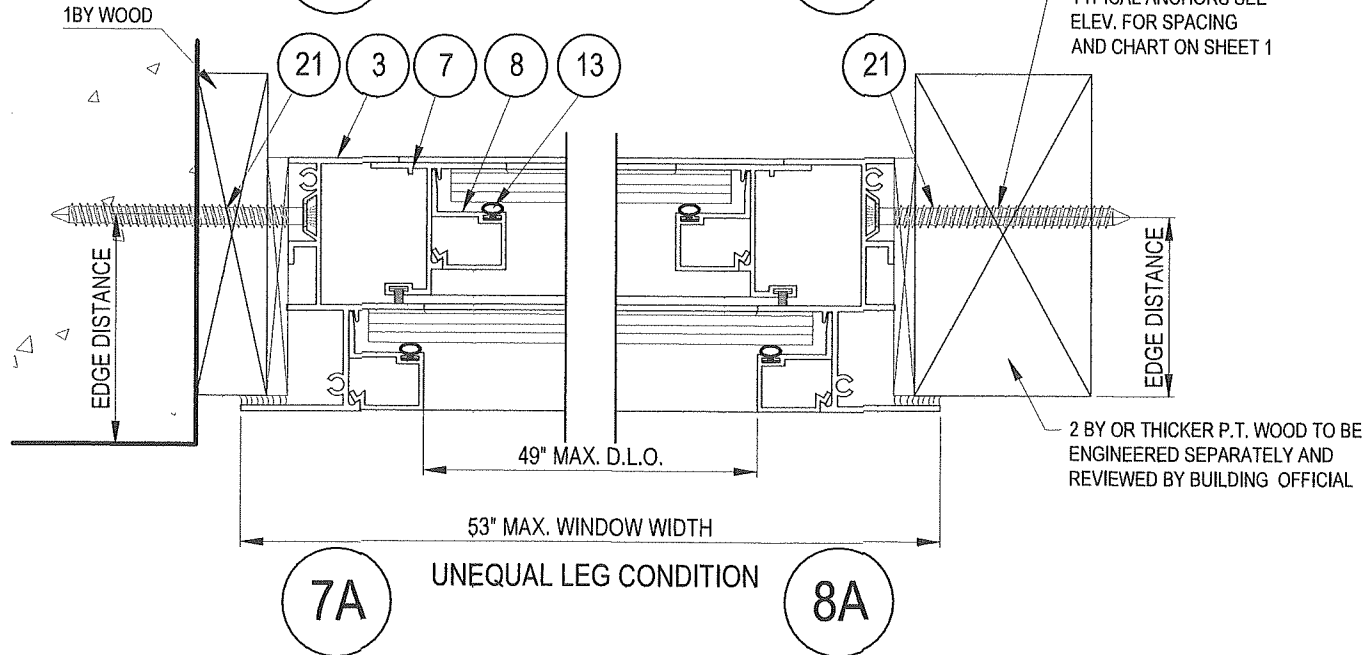
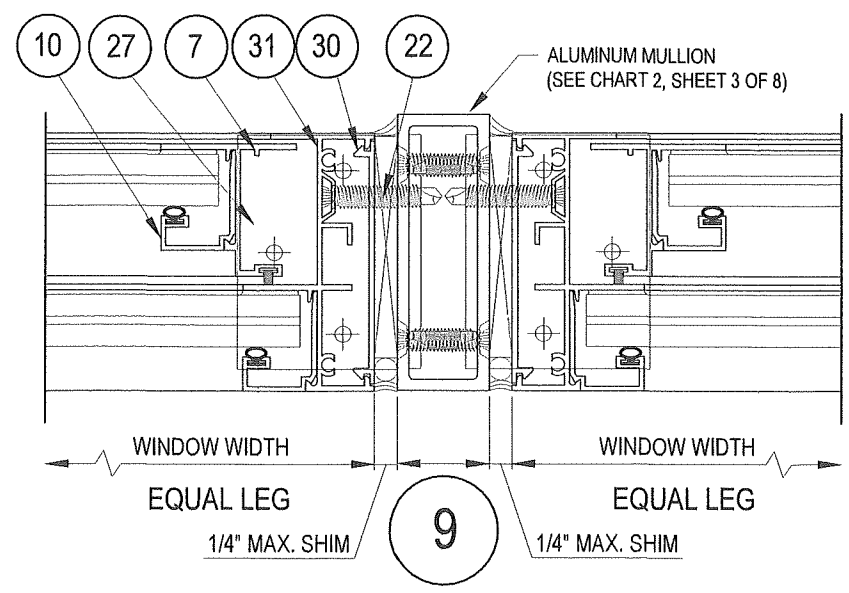
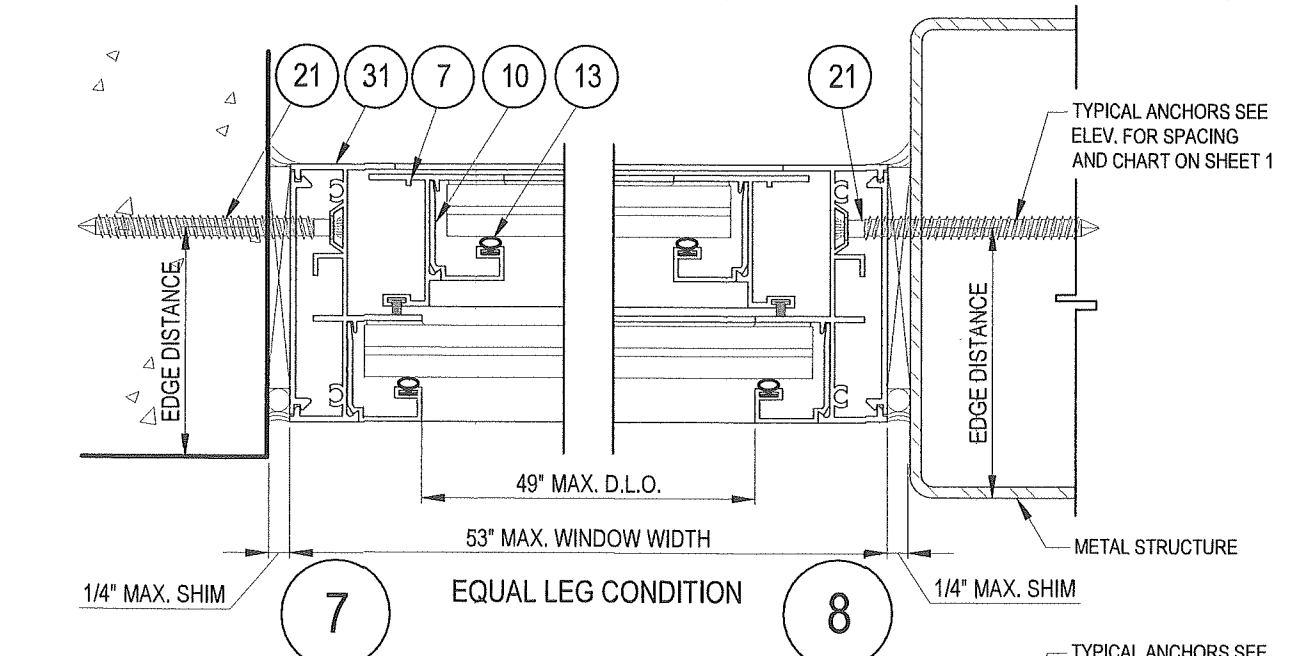

PRODUCT REVISED
 As complying with the Florida Building Code
 NOA-No. **26-0311.03**
 Expiration Date: **08/15/2029**
 By: *Manuel Perez*
 Miami-Dade Product Control

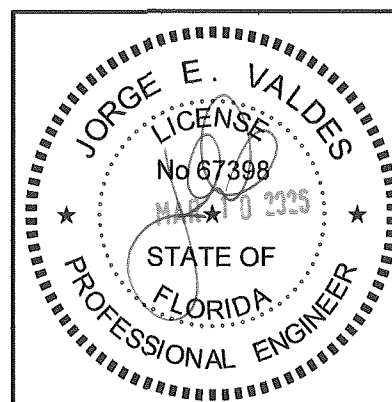

Miami Wall Systems, Inc.
 701 West 25th Street
 Hialeah, Florida. 33010
 Phone: (305) 888-2300 Fax: (305) 888-3058

SINGLE HUNG WINDOW 122 SERIES (LMD)
 HORIZONTAL SECTIONS

| NO. | DATE | REVISION |
|-----|-----------|--------------------|
| 1 | 5/20/2019 | UPDATE TO 2017 FBC |
| 2 | 3/16/2021 | UPDATE TO 2020 FBC |
| 3 | 3/10/2026 | UPDATE TO 2023 FBC |

DATE: 9/4/2008
 SCALE: 1:2
 DWG. BY: L.R.A.
 CHK. BY: JV
 DWG NO.: 122-SH-LM
 SHEET 6 OF 8

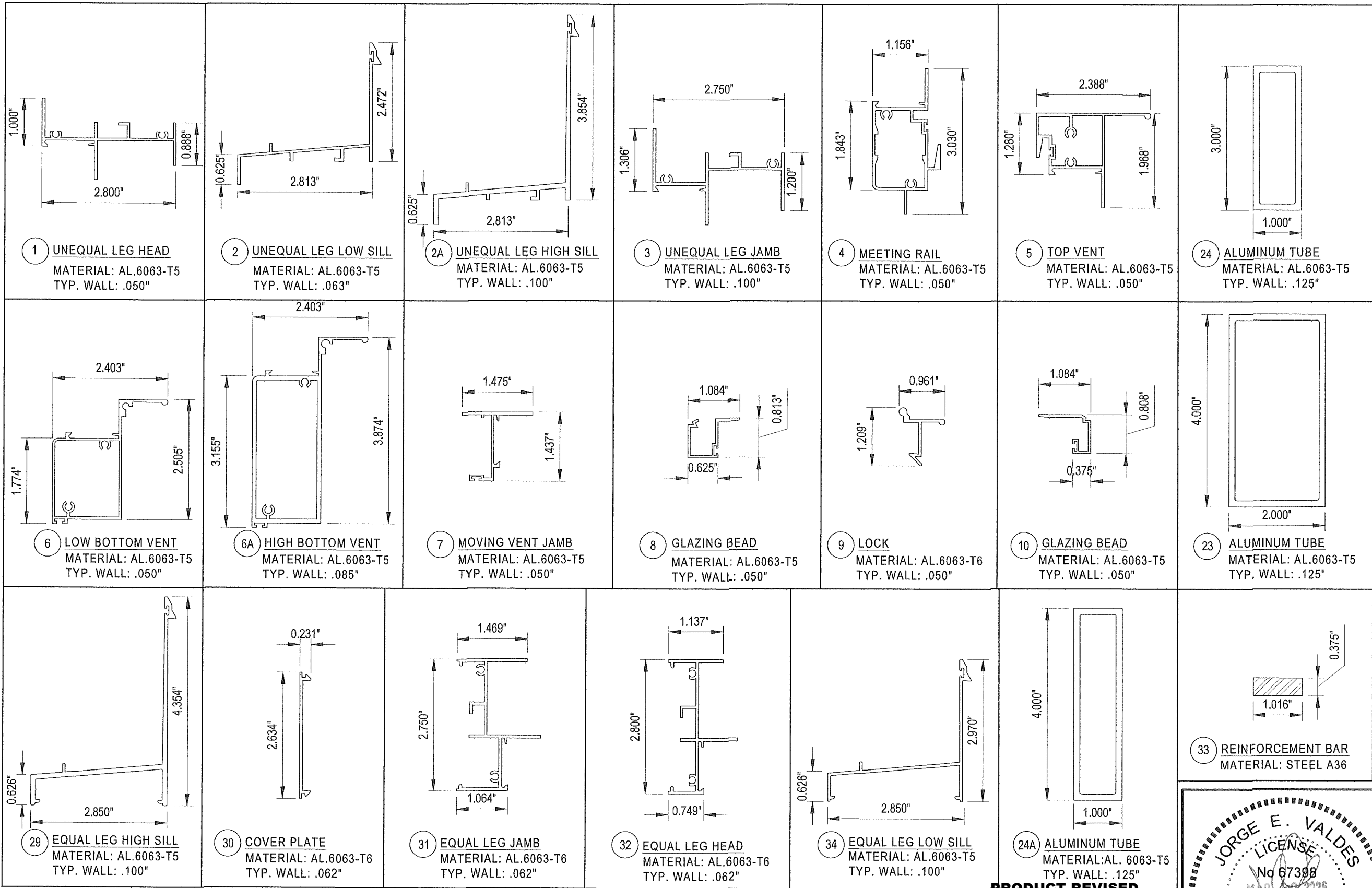

1 UNEQUAL LEG HEAD
MATERIAL: AL.6063-T5
TYP. WALL: .050"

2 UNEQUAL LEG LOW SILL
MATERIAL: AL.6063-T5
TYP. WALL: .063"

2A UNEQUAL LEG HIGH SILL
MATERIAL: AL.6063-T5
TYP. WALL: .100"

3 UNEQUAL LEG JAMB
MATERIAL: AL.6063-T5
TYP. WALL: .100"

4 MEETING RAIL
MATERIAL: AL.6063-T5
TYP. WALL: .050"

5 TOP VENT
MATERIAL: AL.6063-T5
TYP. WALL: .050"

24 ALUMINUM TUBE
MATERIAL: AL.6063-T5
TYP. WALL: .125"

6 LOW BOTTOM VENT
MATERIAL: AL.6063-T5
TYP. WALL: .050"

6A HIGH BOTTOM VENT
MATERIAL: AL.6063-T5
TYP. WALL: .085"

7 MOVING VENT JAMB
MATERIAL: AL.6063-T5
TYP. WALL: .050"

8 GLAZING BEAD
MATERIAL: AL.6063-T5
TYP. WALL: .050"

9 LOCK
MATERIAL: AL.6063-T6
TYP. WALL: .050"

10 GLAZING BEAD
MATERIAL: AL.6063-T5
TYP. WALL: .050"

23 ALUMINUM TUBE
MATERIAL: AL.6063-T5
TYP. WALL: .125"

29 EQUAL LEG HIGH SILL
MATERIAL: AL.6063-T5
TYP. WALL: .100"

30 COVER PLATE
MATERIAL: AL.6063-T6
TYP. WALL: .062"

31 EQUAL LEG JAMB
MATERIAL: AL.6063-T6
TYP. WALL: .062"

32 EQUAL LEG HEAD
MATERIAL: AL.6063-T6
TYP. WALL: .062"

34 EQUAL LEG LOW SILL
MATERIAL: AL.6063-T5
TYP. WALL: .100"

24A ALUMINUM TUBE
MATERIAL: AL.6063-T5
TYP. WALL: .125"

33 REINFORCEMENT BAR
MATERIAL: STEEL A36

PRODUCT REVISED
As complying with the Florida Building Code
NOA-No. **26-0311.03**
Expiration Date: **08/15/2029**
By: *Manuel Ferrer*
Miami-Dade Product Control

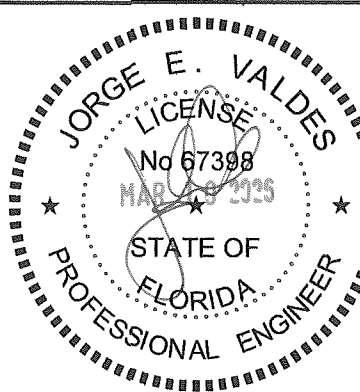

Miami Wall Systems, Inc.
701 West 25th Street
Hialeah, Florida. 33010
Phone: (305) 888-2300 Fax: (305) 888-3058

SINGLE HUNG WINDOW 122 SERIES (LMI)
EXTRUSION DETAILS

| NO. | DATE | REVISION |
|-----|-----------|--------------------|
| 1 | 5/20/2019 | UPDATE TO 2017 FBC |
| 2 | 3/16/2021 | UPDATE TO 2020 FBC |
| 3 | 3/10/2026 | UPDATE TO 2023 FBC |
| | | |
| | | |
| | | |

DATE: 9/4/2008
SCALE: 1:2
DWG. BY: L.R.A.
CHK. BY: JV
DWG NO.: 122-SH-LM
SHEET 7 OF 8

