



MIAMI-DADE COUNTY, FLORIDA  
**PRODUCT CONTROL SECTION**  
 11805 SW 26 Street, Room 208  
 Miami, Florida 33175-2474  
 T (786) 315-2590 F (786) 315-2599  
[www.miamidade.gov/economy](http://www.miamidade.gov/economy)

DEPARTMENT OF REGULATORY AND ECONOMIC RESOURCES (RER)  
 BOARD AND CODE ADMINISTRATION DIVISION  
**NOTICE OF ACCEPTANCE (NOA)**

**Miami Wall Systems, Inc.**  
**701 West 25 Street**  
**Hialeah, FL 33010**

**SCOPE:**

This NOA is being issued under the applicable rules and regulations governing the use of construction materials. The documentation submitted has been reviewed and accepted by Miami-Dade County RER - Product Control Section to be used in Miami Dade County and other areas where allowed by the Authority Having Jurisdiction (AHJ).

This NOA shall not be valid after the expiration date stated below. The Miami-Dade County Product Control Section (In Miami-Dade County) and/ or the AHJ (in areas other than Miami-Dade County) reserve the right to have this product or material tested for quality assurance purposes. If this product or material fails to perform in the accepted manner, the manufacturer will incur the expense of such testing and the AHJ may immediately revoke, modify, or suspend the use of such product or material within their jurisdiction. RER reserves the right to revoke this acceptance, if it is determined by Miami-Dade County Product Control Section that this product or material fails to meet the requirements of the applicable building code.

This product is approved as described herein and has been designed to comply with the Florida Building Code, including the High Velocity Hurricane Zone.

**DESCRIPTION: Series "122" Aluminum Fixed Window – L.M.I.**

**APPROVAL DOCUMENT:** Drawing No. **122-FIXED(LM)**, titled "Fixed Window 122 Series (LMI)", sheets 1 through 6 of 6, dated 10/15/08, with revision #3 dated 03/10/26, prepared by manufacturer, signed and sealed by Jorge E. Valdes, P.E., bearing the Miami-Dade County Product Control Revision stamp with the Notice of Acceptance number and expiration date by the Miami-Dade County Product Control Section.

**MISSILE IMPACT RATING: Large and Small Missile Impact Resistant**

**LABELING:** Each unit shall bear a permanent label with the manufacturer's name or logo, city, state, model/series, and following statement: "Miami-Dade County Product Control Approved", unless otherwise noted herein.

**RENEWAL** of this NOA shall be considered after a renewal application has been filed and there has been no change in the applicable building code negatively affecting the performance of this product.

**TERMINATION** of this NOA will occur after the expiration date or if there has been a revision or change in the materials, use, and/ or manufacture of the product or process. Misuse of this NOA as an endorsement of any product, for sales, advertising or any other purposes shall automatically terminate this NOA. Failure to comply with any section of this NOA shall be cause for termination and removal of NOA.

**ADVERTISEMENT:** The NOA number preceded by the words Miami-Dade County, Florida, and followed by the expiration date may be displayed in advertising literature. If any portion of the NOA is displayed, then it shall be done in its entirety.

**INSPECTION:** A copy of this entire NOA shall be provided to the user by the manufacturer or its distributors and shall be available for inspection at the job site at the request of the Building Official.

This NOA **revises and renews NOA No. 21-0628.13** and consists of this page 1 and evidence pages E-1, E-2, E-3 and E-4, as well as approval document mentioned above.

The submitted documentation was reviewed by **Manuel Perez, P.E.**

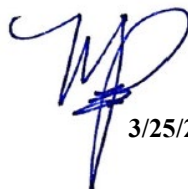

  
 3/25/26

NOA No. 26-0311.05  
 Expiration Date: May 07, 2030  
 Approval Date: April 02, 2026  
 Page 1

**Miami Wall Systems, Inc.**

**NOTICE OF ACCEPTANCE: EVIDENCE SUBMITTED**

**1. EVIDENCE SUBMITTED UNDER PREVIOUS NOA's**

**A. DRAWINGS**

1. Manufacturer's die drawings and sections.  
*(Submitted under NOA No. 04-0303.04)*
2. Drawing No. **122-FIXED(LM)**, titled "Fixed Window 122 Series (LMI)", sheets 1 through 6 of 6, dated 10/15/08, with revision #2 dated 03/16/21, prepared by manufacturer, signed and sealed by Jorge E. Valdes, P.E.  
*(Submitted under NOA No. 21-0628.13)*

**B. TESTS**

1. Test report on: 1) Air Infiltration Test, per FBC, TAS 202-94  
2) Uniform Static Air Pressure Test, Loading per FBC TAS 202-94  
3) Water Resistance Test, per FBC, TAS 202-94  
4) Large Missile Impact Test per FBC, TAS 201-94  
5) Cyclic Wind Pressure Loading per FBC, TAS 203-94  
6) Forced Entry Test, per FBC 2411 3.2.1, TAS 202-94  
along with marked-up drawings and installation diagram of a series 122 single hung muller to fixed window, prepared by Fenestration Testing Laboratory, Inc., Test Report No. **FTL-12615**, dated June 16, 2021, signed and sealed by Idalmis Ortega, P.E.  
*(Submitted under NOA No. 21-0628.13)*
2. Test reports on: 1) Air Infiltration Test, per FBC, TAS 202-94  
2) Uniform Static Air Pressure Test, Loading per FBC TAS 202-94  
3) Water Resistance Test, per FBC, TAS 202-94  
4) Large Missile Impact Test per FBC, TAS 201-94  
5) Cyclic Wind Pressure Loading per FBC, TAS 203-94  
6) Forced Entry Test, per FBC 2411 3.2.1, TAS 202-94  
along with marked-up drawings and installation diagram of an aluminum casement window muller to a fixed window, prepared by Fenestration Testing Laboratory, Inc., Test Report No. **FTL-5595**, dated 06/06/08, signed and sealed by Carlos Rionda, P.E.  
*(Submitted under NOA No. 08-0729.01)*
3. Test reports on: 1) Uniform Static Air Pressure Test, Loading per FBC, TAS 202-94  
along with marked-up drawings and installation diagram of a series 122 aluminum equal leg fixed window, prepared by Fenestration Testing Laboratory, Inc., Test Report No. **FTL-4225**, dated 05/06/04, signed and sealed by Edmundo Largaespada, P.E.  
*(Submitted under NOA No. 04-0322.09)*

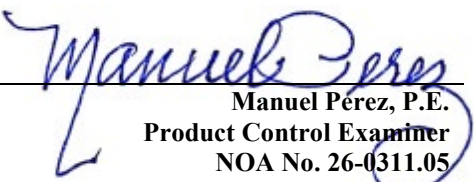
  
Manuel Pérez, P.E.  
Product Control Examiner  
NOA No. 26-0311.05  
Expiration Date: May 07, 2030  
Approval Date: April 02, 2026

**NOTICE OF ACCEPTANCE: EVIDENCE SUBMITTED**

**1. EVIDENCE SUBMITTED UNDER PREVIOUS NOA's (CONTINUED)**  
**B. TESTS (CONTINUED)**

4. Test reports on: 1) Air Infiltration Test, per FBC, TAS 202-94  
2) Uniform Static Air Pressure Test, Loading per FBC TAS 202-94  
3) Water Resistance Test, per FBC, TAS 202-94  
4) Large Missile Impact Test per FBC, TAS 201-94  
5) Cyclic Wind Pressure Loading per FBC, TAS 203-94  
6) Forced Entry Test, per FBC 2411 3.2.1, TAS 202-94

along with marked-up drawings and installation diagram of a series 122 aluminum equal leg fixed window, prepared by Fenestration Testing Laboratory, Inc., Test Report No. **FTL-4091**, dated 02/20/04, signed and sealed by Edmundo Largaespada, P.E.

*(Submitted under NOA No. 04-0322.09)*

- 5 Test reports on: 1) Air Infiltration Test, per FBC, TAS 202-94  
2) Uniform Static Air Pressure Test, Loading per FBC TAS 202-94  
3) Water Resistance Test, per FBC, TAS 202-94  
4) Large Missile Impact Test per FBC, TAS 201-94  
5) Cyclic Wind Pressure Loading per FBC, TAS 203-94  
6) Forced Entry Test, per FBC 2411 3.2.1, TAS 202-94

along with marked-up drawings and installation diagram of an aluminum single hung window muller to a fixed window, prepared by Fenestration Testing Laboratory, Inc., Test Report No. **FTL-3386**, dated 05/01/02, signed and sealed by Luis Antonio Figueredo, P.E.

*(Submitted under NOA No. 04-0303.04)*

6. Test report on: 1) Air Infiltration Test, per FBC, TAS 202-94  
2) Uniform Static Air Pressure Test, Loading per FBC TAS 202-94  
3) Water Resistance Test, per FBC, TAS 202-94  
4) Large Missile Impact Test per FBC, TAS 201-94  
5) Cyclic Wind Pressure Loading per FBC, TAS 203-94  
6) Forced Entry Test, per FBC 2411 3.2.1, TAS 202-94

along with marked-up drawings and installation diagram of an aluminum single hung muller unequal leg fixed windows, prepared by Fenestration Testing Laboratory, Inc., Test Report No. **FTL-3385**, dated 05/03/02, signed and sealed by Luis Antonio Figueredo, P.E.

*(Submitted under NOA No. 04-0303.04)*

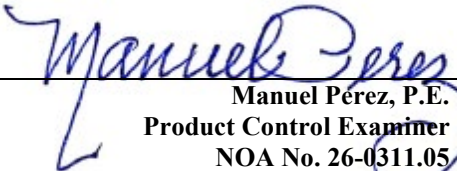
  
\_\_\_\_\_  
Manuel Pérez, P.E.  
Product Control Examiner  
NOA No. 26-0311.05  
Expiration Date: May 07, 2030  
Approval Date: April 02, 2026

**Miami Wall Systems, Inc.**

**NOTICE OF ACCEPTANCE: EVIDENCE SUBMITTED**

**1. EVIDENCE SUBMITTED UNDER PREVIOUS NOA's (CONTINUED)**

**C. CALCULATIONS**

1. Anchor verification calculations and structural analysis, complying with FBC 7<sup>th</sup> Edition (2020), dated 09/29/21, prepared by manufacturer, signed and sealed by Jorge E. Valdes, P.E.  
*(Submitted under NOA No. 21-0628.13)*
2. Glazing complies with **ASTM E1300-09**

**D. QUALITY ASSURANCE**

1. Miami-Dade Department of Regulatory and Economic Resources (RER)

**E. MATERIAL CERTIFICATIONS**

1. Notice of Acceptance No. **20-0915.22** issued to **Kuraray America, Inc.** for their "Trosifol® Ultraclear, Clear and Color PVB Glass Interlayers" dated 11/19/20, expiring on 07/08/24.
2. Notice of Acceptance No. **20-0915.19** issued to **Kuraray America, Inc.** for their "SentryGlas® (Clear and White) Glass Interlayers" dated 11/19/20, expiring on 07/04/23.

**F. STATEMENTS**

1. Statement letters of conformance, complying with **FBC 7<sup>th</sup> Edition (2020)**, dated August 31, 2021, prepared by manufacturer, signed and sealed by Jorge E. Valdes, P.E.  
*(Submitted under NOA No. 21-0628.13)*
2. Statement letters of no financial interest, dated August 31, 2021, prepared by manufacturer, signed and sealed by Jorge E. Valdes, P.E.  
*(Submitted under NOA No. 21-0628.13)*
3. Proposal No. **21-0333** issued by the Product Control Section, dated April 30, 2021, signed by Manuel Perez, P.E.  
*(Submitted under NOA No. 21-0628.13)*

**G. OTHERS**

1. Notice of Acceptance No. **20-0417.01**, issued to Miami Wall Systems, Inc. for their Series "122" Aluminum Fixed Window - L.M.I., approved on 05/07/20 and expiring on 05/07/25.

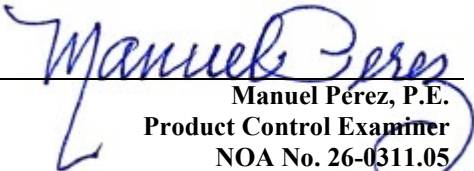
  
\_\_\_\_\_  
Manuel Pérez, P.E.  
Product Control Examiner  
NOA No. 26-0311.05  
Expiration Date: May 07, 2030  
Approval Date: April 02, 2026

**Miami Wall Systems, Inc.**

**NOTICE OF ACCEPTANCE: EVIDENCE SUBMITTED**

**2. NEW EVIDENCE SUBMITTED**

**A. DRAWINGS**

1. Drawing No. **122-FIXED(LM)**, titled “Fixed Window 122 Series (LMI)”, sheets 1 through 6 of 6, dated 10/15/08, with revision #3 dated 03/10/26, prepared by manufacturer, signed and sealed by Jorge E. Valdes, P.E.

**B. TESTS**

1. None.

**C. CALCULATIONS**

1. None.

**D. QUALITY ASSURANCE**

1. Miami-Dade Department of Regulatory and Economic Resources (RER)

**E. MATERIAL CERTIFICATIONS**

1. Notice of Acceptance No. **24-0205.08** issued to **Kuraray America, Inc.** for their “**Trosifol® Ultraclear, Clear and Color PVB Glass Interlayers**” dated 03/21/24, expiring on 07/08/29.
2. Notice of Acceptance No. **23-0717.30** issued to **Kuraray America, Inc.** for their “**SentryGlas® (Clear and White) Glass Interlayers**” dated 08/31/23, expiring on 07/04/28.

**F. STATEMENTS**

1. Statement letters of conformance, complying with **FBC 8<sup>th</sup> Edition (2023)**, dated March 10, 2026, prepared by manufacturer, signed and sealed by Jorge E. Valdes, P.E.
2. Statement letters of no financial interest, dated March 24, 2026, prepared by manufacturer, signed and sealed by Jorge E. Valdes, P.E.

**G. OTHERS**

1. Notice of Acceptance No. **21-0628.13**, issued to Miami Wall Systems, Inc. for their Series “122” Aluminum Fixed Window - L.M.I., approved on 11/24/21 and expiring on 05/07/25.

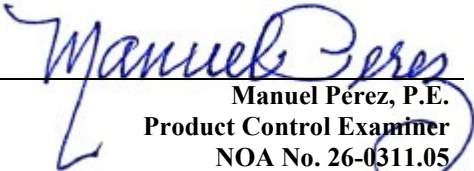
  
\_\_\_\_\_  
Manuel Pérez, P.E.  
Product Control Examiner  
NOA No. 26-0311.05  
Expiration Date: May 07, 2030  
Approval Date: April 02, 2026

**SERIES 122 ALUMINUM FIXED WINDOW (L.M.I.)**

**GENERAL NOTES:**

1. THIS PRODUCT HAS BEEN DESIGNED AND TESTED IN ACCORDANCE WITH THE 2023 FLORIDA BUILDING CODE 8TH EDITION (HIGH VELOCITY HURRICANE ZONE)
2. WOOD BUCKS AND BUCK FASTENERS BY OTHERS. MUST BE ENGINEERED AND INSTALLED ADEQUATELY TO TAKE THE WIND LOADS IMPOSED BY WINDOWS AND TRANSFER THEM TO THE BUILDING STRUCTURE.
3. FRAME CORNERS, FIXED PANEL & MULLION SEALED WITH SILICONE SEALANT.
4. ALL INSTALLATION SCREW HOLES ARE IN-FACTORY PRE-PUNCHED FOR 1/4" DIAMETER FLAT HEAD SCREWS. FASTENERS TO BE CORROSION RESISTANT, SPACED AS SHOWN ON DETAILS AND INSTALLED IN ACCORDANCE WITH MANUFACTURERS' INSTRUCTIONS.
5. EQUAL AND UNEQUAL LEG FRAME CONDITIONS INCLUDED.
6. THIS APPROVAL IS APPLICABLE TO SINGLE FIXED WINDOW UNITS OR SIDE-BY-SIDE COMBINATIONS OF FIXED WINDOW WITH FIXED WINDOW OR FIXED WINDOW WITH SINGLE HUNG WINDOW IN MODULES OF 2 OR MORE WINDOWS USING MULLIONS IN BETWEEN, AS SHOWN ON DETAILS.
7. UNCLIPPED VERTICAL MULLION APPLICATIONS SHALL BE LIMITED TO APPROVED WINDOW DIMENSIONS (SEE GLASS LOAD CHART 1, SHEET 2 OF 6 AND MULLION LOAD CHART 2, SHEET 3 OF 6 FOR DETAILS)
8. USE CLUSTER OF (4) ANCHORS AT SILL AND HEAD WHERE UNCLIPPED VERTICAL MULLIONS OCCUR ONLY (SEE DETAIL "A", SHEET 3 OF 6)

**INSTRUCTIONS:**

- STEP 1 -** DETERMINATE DESIGN WIND LOAD REQUIREMENT BASED ON WIND VELOCITY, BUILDING HEIGHT, WIND ZONE USING APPLICABLE **ASCE 7** STANDARD.
- STEP 2 -** SEE CHART 1 ON SHEET 2 OF 6 FOR DESIGN LOAD CAPACITY OF DESIRED GLASS SIZE.
- STEP 3 -** IF WINDOWS ARE TO BE MULLED TOGETHER, CHECK MULLION CAPACITY FOR A GIVEN SPACING AND HEIGHT USING CHART 2 ON SHEET 3 OF 6. THE CAPACITY SHOULD EXCEED THE DESIGN LOAD.
- STEP 4 -** THE LOWEST VALUE RESULTING FROM STEP 2 AND 3 SHALL APPLY TO ENTIRE SYSTEM.

THIS PRODUCT IS RATED LARGE AND SMALL MISSILE IMPACT. SHUTTERS ARE NOT REQUIRED.

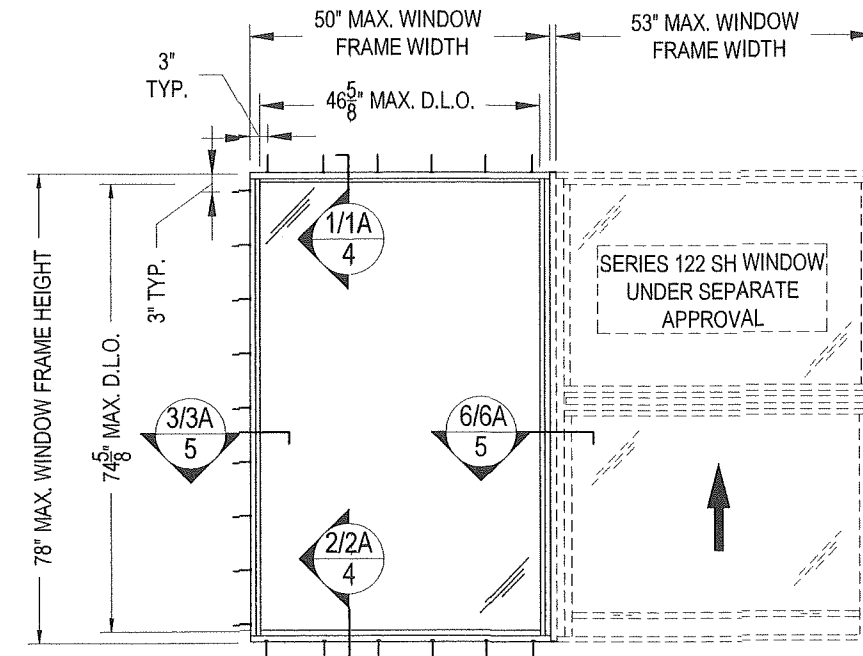
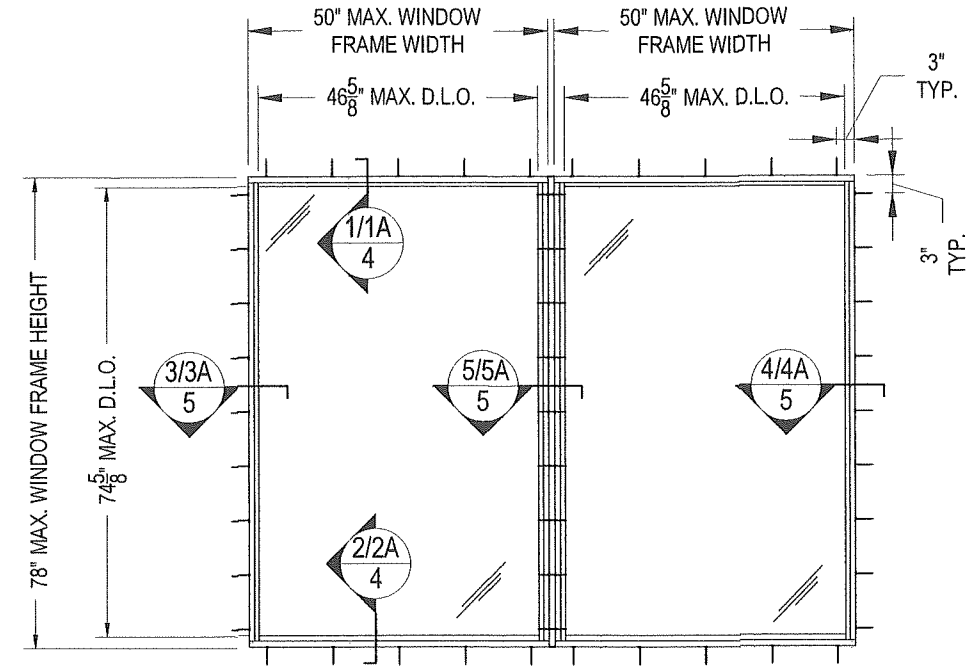
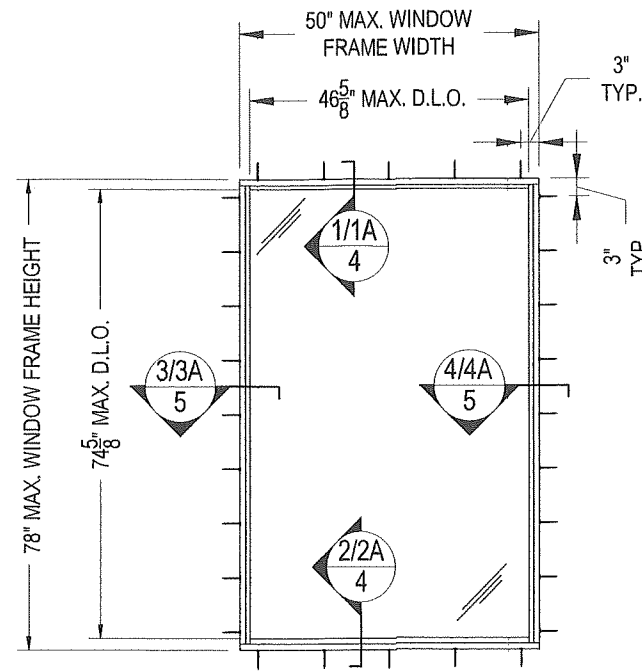

**PRODUCT REVISED**  
 As complying with the Florida Building Code  
**NOA-No. 26-0311.05**  
 Expiration Date: **05/07/2030**  
 By: *Manuel Fern*  
 Miami-Dade Product Control

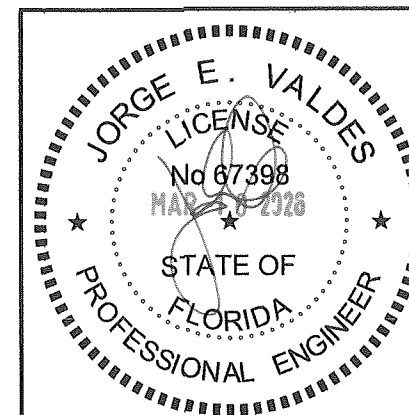

*Miami Wall Systems, Inc.*  
 701 West 25th Street  
 Hialeah, Florida. 33010  
 Phone: (305) 888-2300 Fax: (305) 888-3058

FIXED WINDOW 122 SERIES (LMI)  
 ELEVATIONS  
 GENERAL NOTES

NO.	DATE	REVISION
1	3/12/2020	UPDATE TO 2017 FBC
2	3/16/2021	UPDATE TO 2020 FBC
3	3/10/2026	UPDATE TO 2023 FBC

DATE: 10/15/2008  
 SCALE: 3/8" = 1'-0"  
 DWG. BY: L.R.A.  
 CHK. BY: JV  
 DWG NO.: 122-FIXED(LM)  
 SHEET 1 OF 6

**CHART 1**

GLASS DESIGN LOAD CAPACITY - PSF							
WINDOW DIMENSION		GLASS TYPE GL-1		GLASS TYPE GL-2		GLASS TYPE GL-3	
SHORT SIDE	LONG SIDE	EXTERIOR (+)	INTERIOR (-)	EXTERIOR (+)	INTERIOR (-)	EXTERIOR (+)	EXTERIOR (+)
48	60	90	90	120	120	130	130
52		84.1	84.1	120	120	120	120
56		79.3	79.3	120	120	90	90
60		74.9	74.9	120	120	90	90
40	64	90	90	120	120	130	130
44		90	90	120	120	120	120
48		85	85	120	120	90	90
52		79.9	79.9	120	120	90	90
56	75.1	75.1	120	120	90	90	
40	68	90	90	120	120	120	120
44		85.6	85.6	120	120	90	90
48		80.8	80.8	120	120	90	90
52		75.9	75.9	120	120	90	90
36	72	88.8	88.8	120	120	120	120
40		85.1	85.1	120	120	90	90
44		80.9	80.9	120	120	90	90
48		76.6	76.6	120	120	90	90
50	74.4	74.4	120	120	90	90	
36	76	82.7	82.7	120	120	120	120
40		79.9	79.9	120	120	90	90
44		76.6	76.6	120	120	90	90
48		72.8	72.8	120	120	90	90
36	78	80.3	80.3	120	120	118	118
40		77.6	77.6	120	120	90	90
44		74.6	74.6	120	120	90	90
46		72.7	72.7	120	120	90	90

**NOTE:**

SHORT SIDE AND LONG SIDE DIMENSIONS CAN BE ORIENTED HORIZONTALLY OR VERTICALLY AS SHOWN BELOW

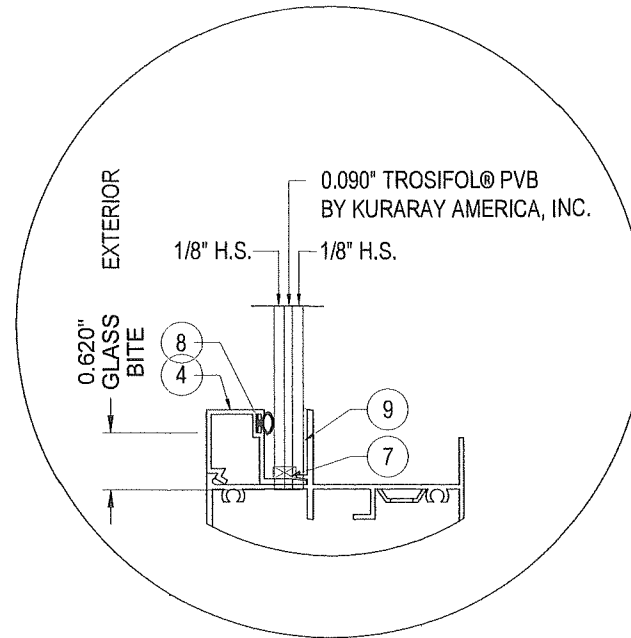
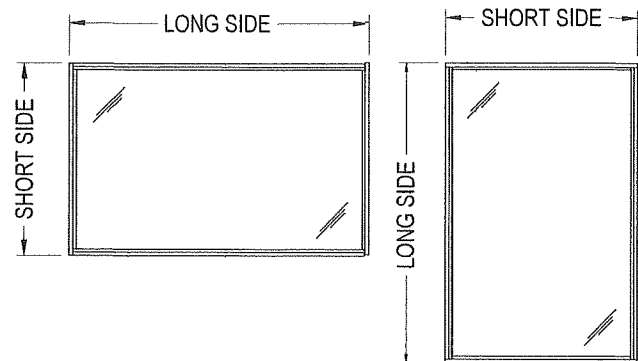

**GLASS TYPE GL-1**  
5/16" OVERALL THICKNESS LAMINATED GLASS

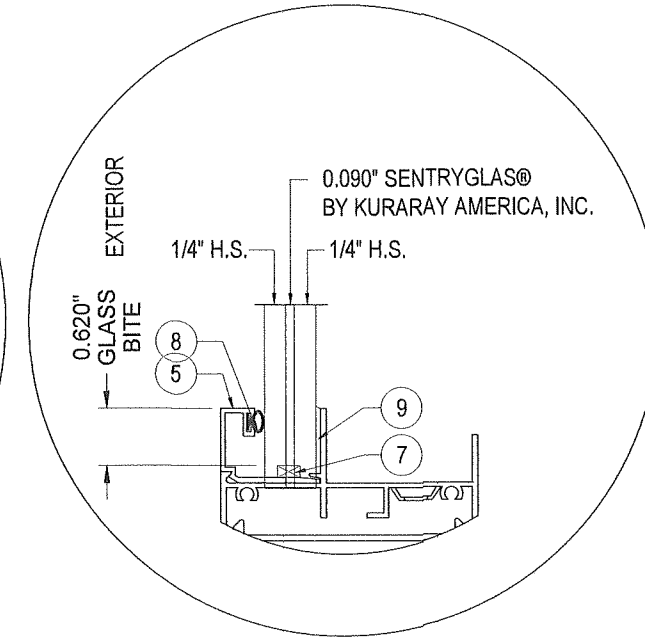

**GLASS TYPE GL-2**  
9/16" OVERALL THICKNESS LAMINATED GLASS

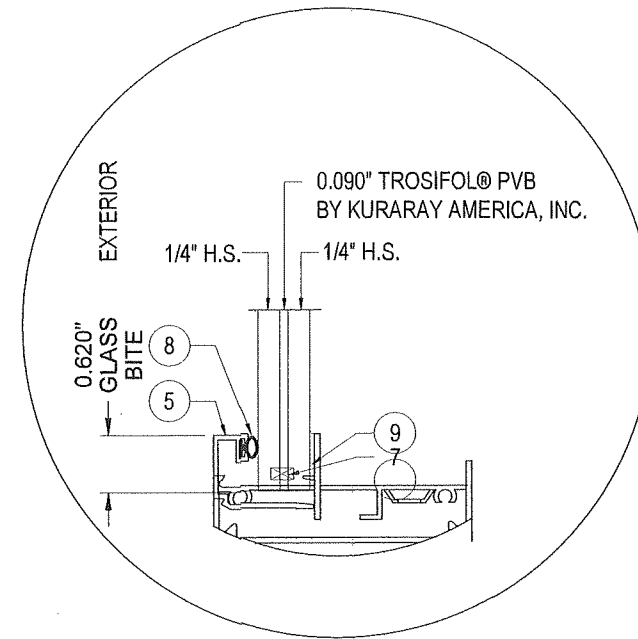

**GLASS TYPE GL-3**  
9/16" OVERALL THICKNESS LAMINATED GLASS

**GLASS OPTIONS**

SCALE 1:2

**PRODUCT REVISED**  
As complying with the Florida Building Code  
NOA-No. **26-0311.05**  
Expiration Date: **05/07/2030**  
By: *Manuel Perez*  
Miami-Dade Product Control

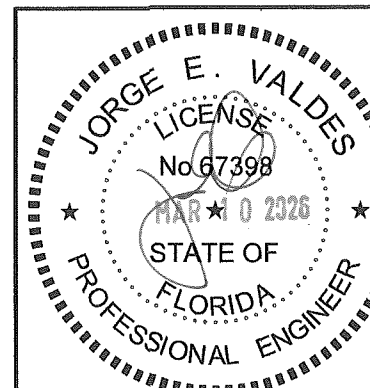

Miami Wall Systems, Inc.  
701 West 25th Street  
Hialeah, Florida, 33010  
Phone: (305) 888-2300 Fax: (305) 888-3058

FIXED WINDOW 122 SERIES (LMI)  
GLASS DESIGN LOAD CHART  
GLASS OPTIONS

NO.	DATE	REVISION
1	3/12/2020	UPDATE TO 2017 FBC
2	3/16/2021	UPDATE TO 2020 FBC
3	3/10/2026	UPDATE TO 2023 FBC

DATE: 10/15/2008  
SCALE: AS NOTED  
DWG. BY: L.R.A.  
CHK. BY: JV  
DWG NO.: 122-FIXED(LM)  
SHEET 2 OF 6

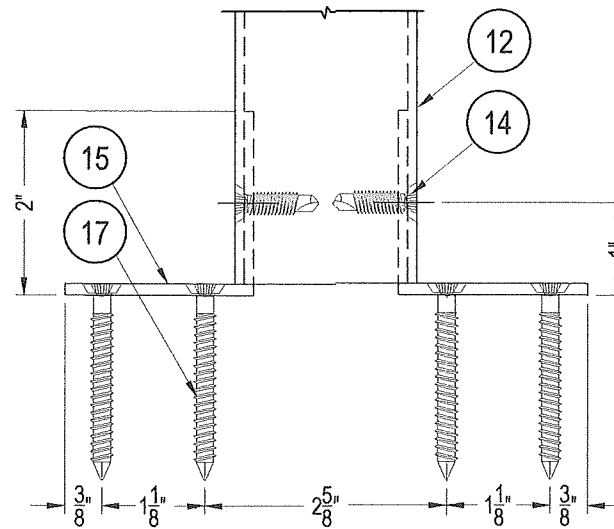
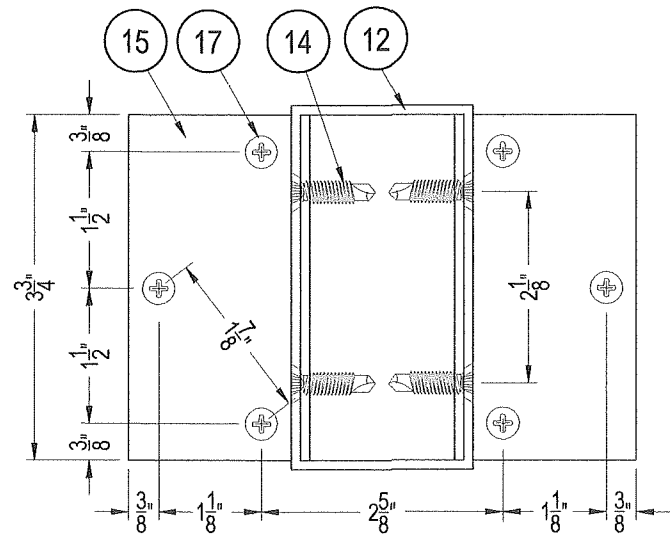

MULLION TYPE 3  
(2 x 4 x 1/8" THK.)

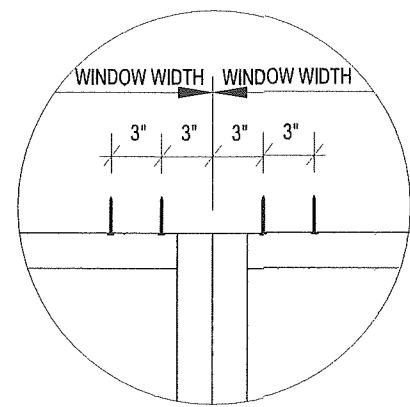

DETAIL "A"

TYPICAL CLUSTER OF ANCHORS  
AT INTERLOCKS TOP & BOTTOM  
(ONLY AT UNCLIPPED MULLION CONDITION)

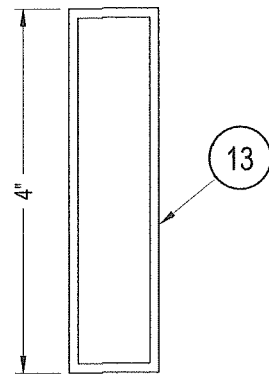

MULLION TYPE 2  
(1 x 4 x 1/8" THK.) UNCLIPPED

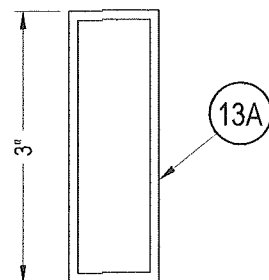

13A



MULLION TYPE 1  
(1 x 3 x 1/8" THK.) UNCLIPPED

CHART 2

MULLION DESIGN LOAD CAPACITY - PSF							
WINDOW DIMENSION		MULLION TYPE 1 (1 x 3 x 1/8")		MULLION TYPE 2 (1 x 4 x 1/8")		MULLION TYPE 3 (2 x 4 x 1/8")	
WIDTH (W)	MULLION SPAN (H)	EXTERIOR (+)	INTERIOR (-)	EXTERIOR (+)	INTERIOR (-)	EXTERIOR (+)	INTERIOR (-)
40	64	120	120	120	120	120	120
44		120	120	120	120	120	120
48		114	114	114	114	120	120
53		110	110	110	110	120	120
38	68	106	106	106	106	120	120
42		100	100	100	100	120	120
46		94	94	94	94	120	120
50		91	91	91	91	120	120
53	72	88	88	90	90	120	120
38		89	89	90	90	120	120
42		82	82	90	90	120	120
46		78	78	90	90	120	120
50	76	74	74	90	90	120	120
53		71	71	90	90	120	120
36		78	78	90	90	-	-
40		71	71	90	90	-	-
44	78	66	66	90	90	-	-
48		62	62	90	90	-	-
36		71	71	90	90	-	-
40		65	65	90	90	-	-
44	80	60	60	90	90	-	-
48		57	57	90	90	-	-

NOTE:

MULLIONS RATED IN THIS CHART MAY BE ORIENTED VERTICALLY OR HORIZONTALLY.  
INTERPOLATION BETWEEN WIDTHS ALLOWED.

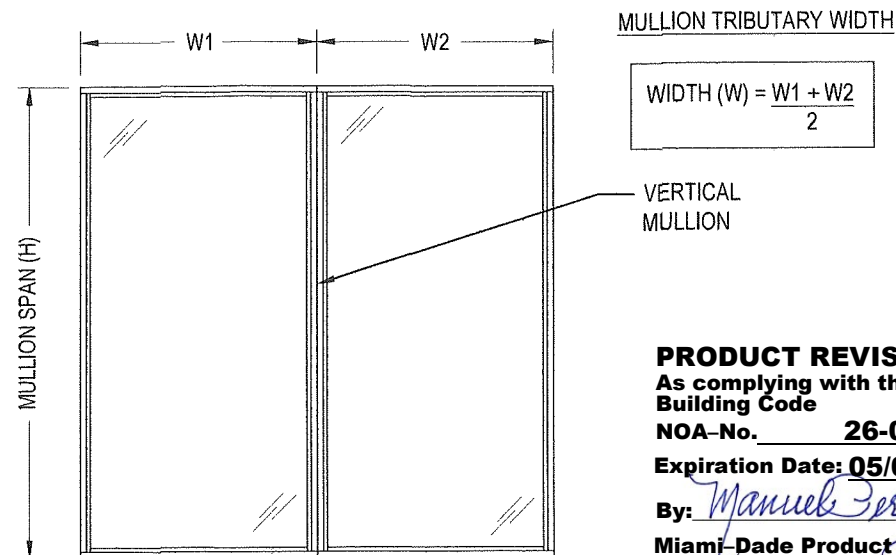

**PRODUCT REVISED**  
As complying with the Florida  
Building Code  
NOA-No. **26-0311.05**  
Expiration Date: **05/07/2030**  
By: *Manuel Perez*  
Miami-Dade Product Control

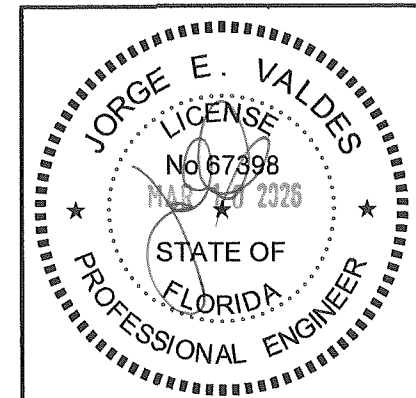

Miami Wall Systems, Inc.  
701 West 25th Street  
Hialeah, Florida, 33010  
Phone: (305) 888-2300 Fax: (305) 888-3058

FIXED WINDOW 122 SERIES (LMI)  
MULLION DESIGN LOAD CHART  
MULLION DETAILS

NO.	DATE	REVISION
1	3/12/2020	UPDATE TO 2017 FBC
2	3/16/2021	UPDATE TO 2020 FBC
3	3/10/2026	UPDATE TO 2023 FBC

DATE: 10/15/2008  
SCALE: 1:2  
DWG. BY: LRA  
CHK. BY: JV  
DWG NO.: 122-FIXED(LM)  
SHEET 3 OF 6

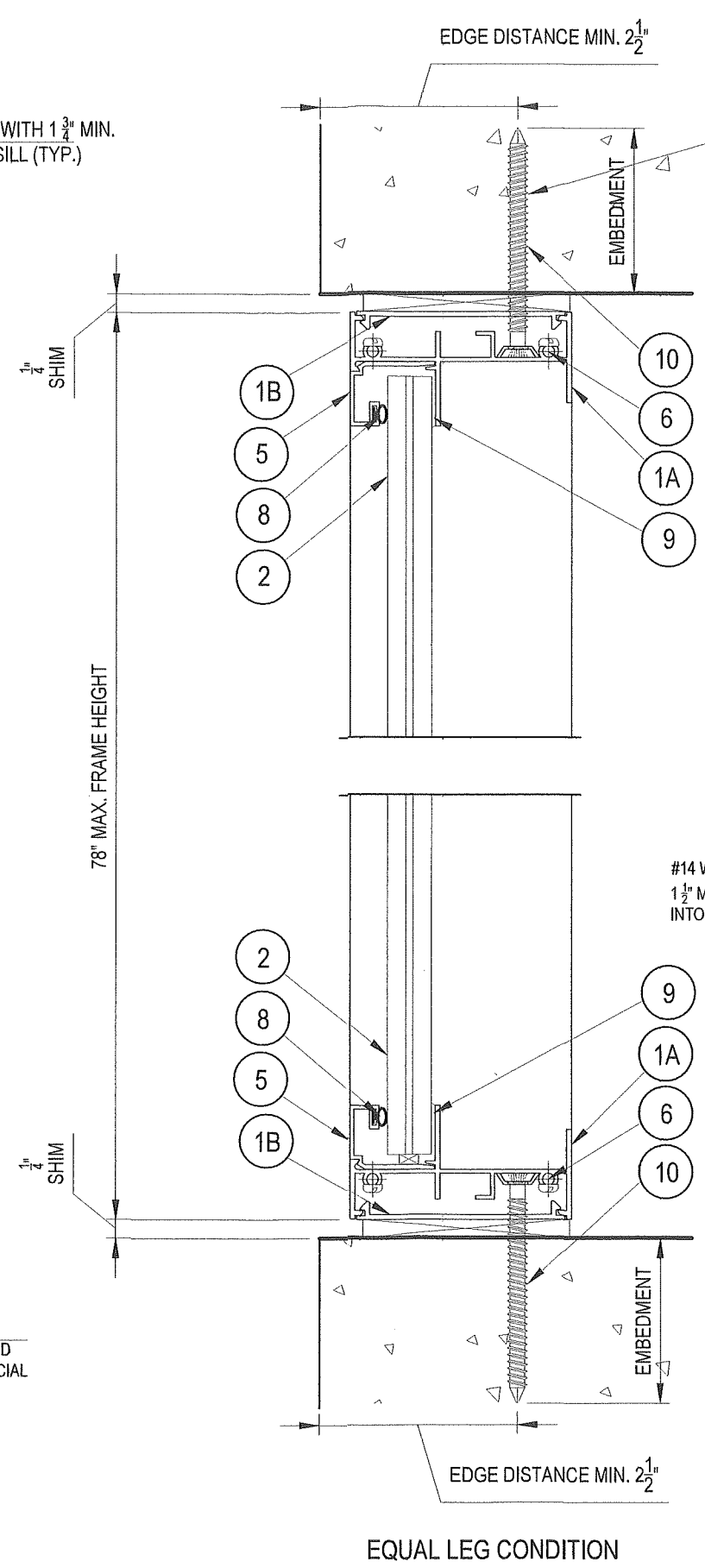
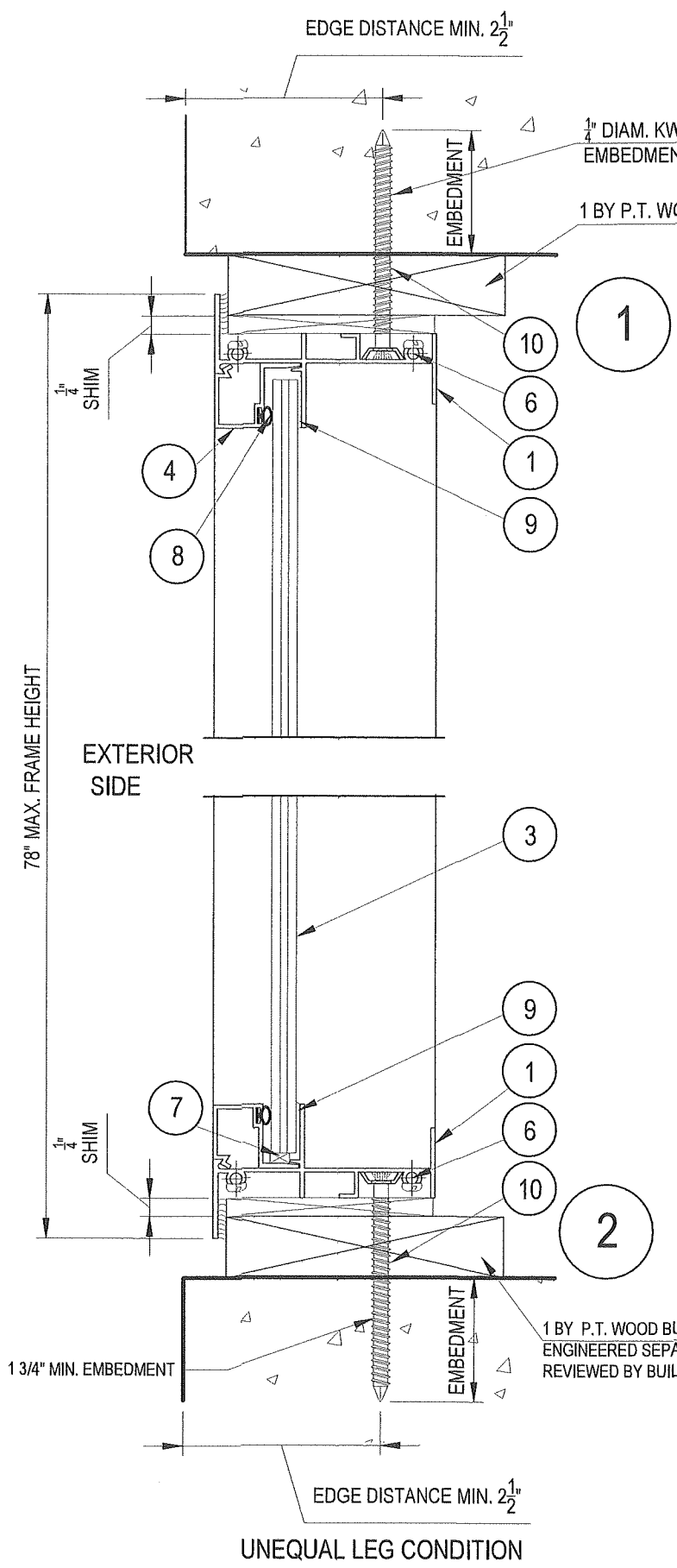

1A

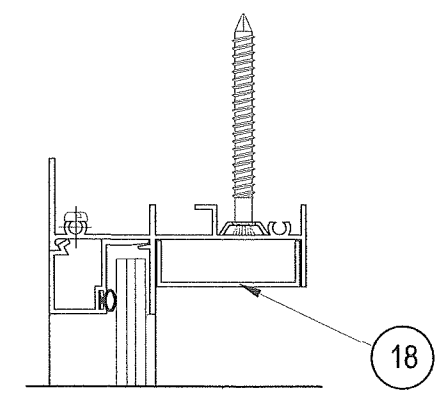

ALTERNATE DETAIL WITH FASTENER COVER

2A

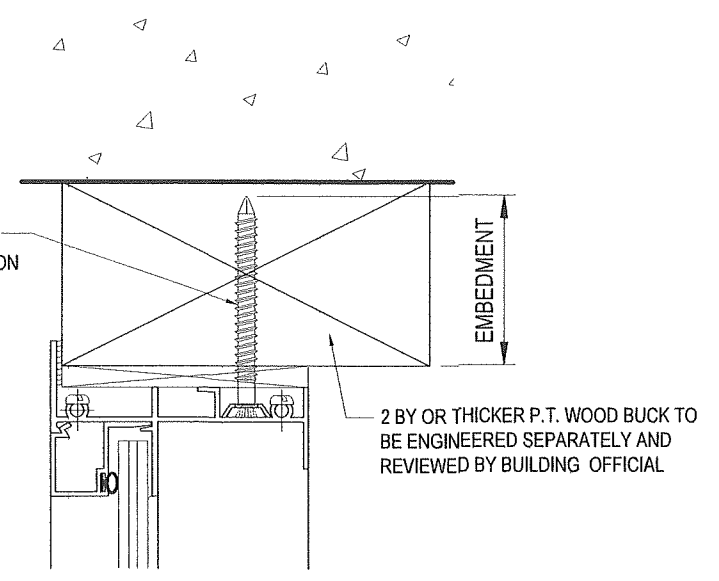

ANCHORAGE OPTION INTO WOOD

**PRODUCT REVISED**  
 As complying with the Florida Building Code  
 NOA-No. **26-0311.05**  
 Expiration Date: **05/07/2030**  
 By: *Manuel Perez*  
 Miami-Dade Product Control

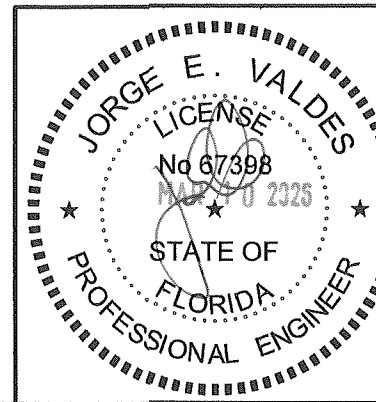

Miami Wall Systems, Inc.  
 701 West 25th Street  
 Hialeah, Florida. 33010  
 Phone: (305) 888-2300 Fax: (305) 888-3058

FIXED WINDOW 122 SERIES (LMI)  
 VERTICAL SECTIONS

NO.	DATE	REVISION
1	3/12/2020	UPDATE TO 2017 FBC
2	3/16/2021	UPDATE TO 2020 FBC
3	3/10/2026	UPDATE TO 2023 FBC

DATE: 10/15/2008  
 SCALE: AS NOTED  
 DWG. BY: L.R.A.  
 CHK. BY: JV  
 DWG NO.: 122-FIXED(LM)  
 SHEET 4 OF 6

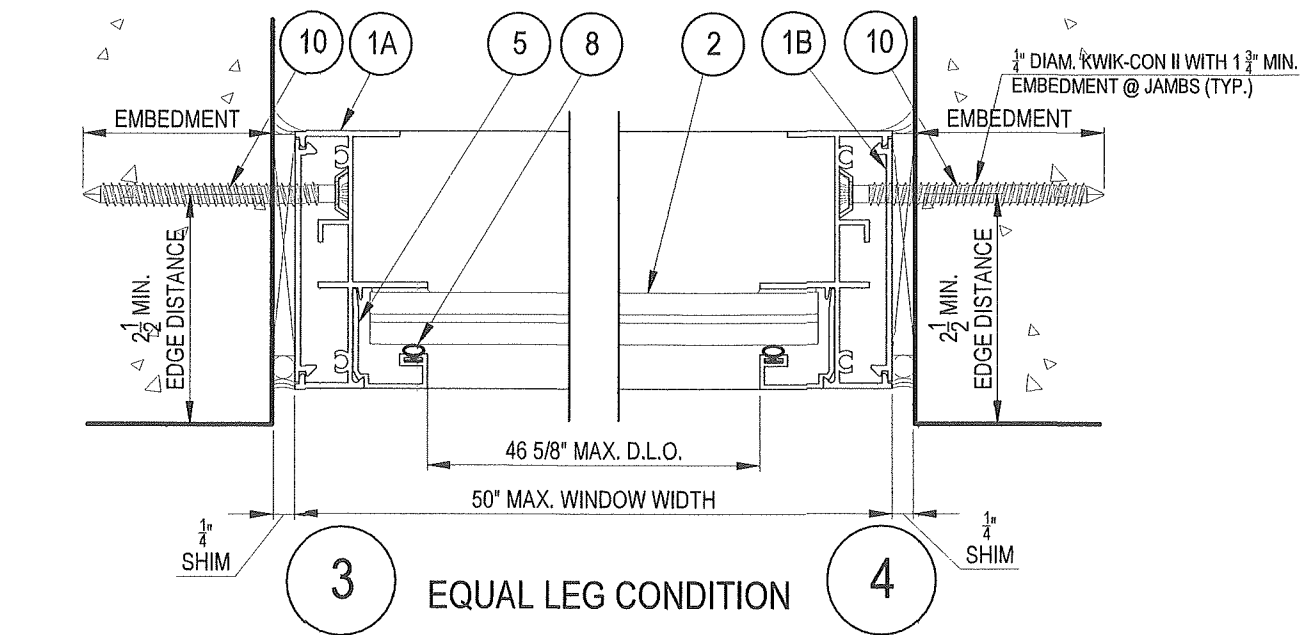

**3** EQUAL LEG CONDITION **4**

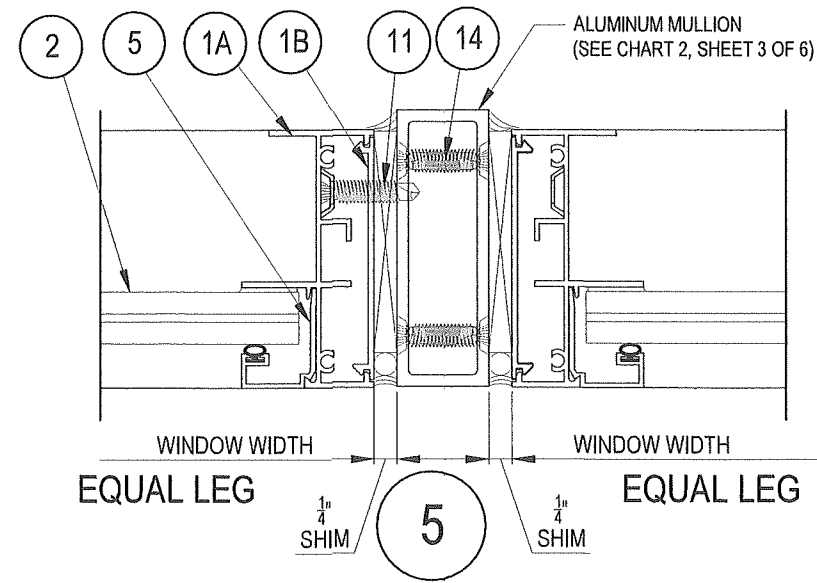

**5** EQUAL LEG

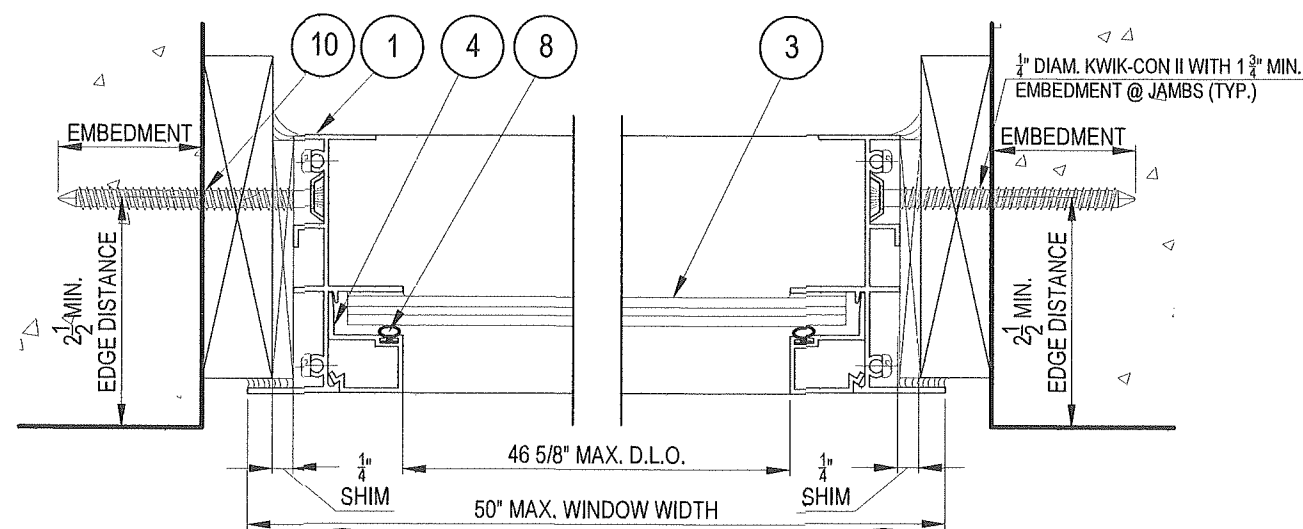

**3A** UNEQUAL LEG CONDITION **4A**

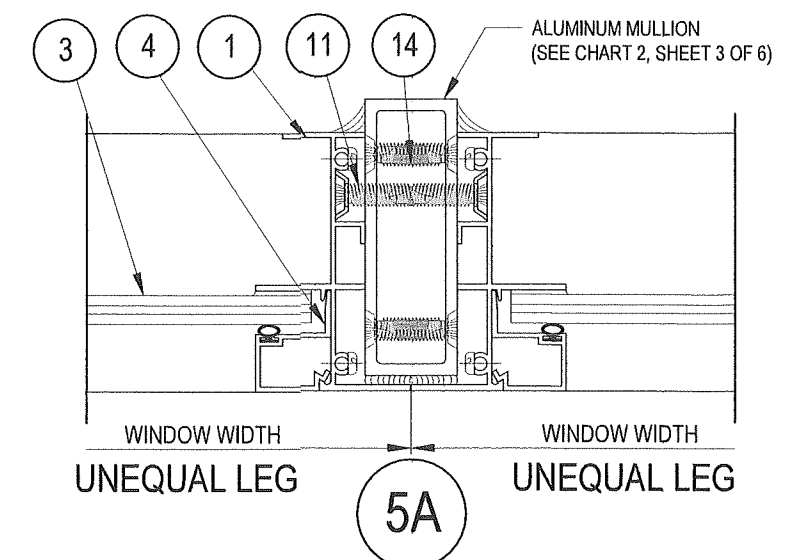

**5A** UNEQUAL LEG

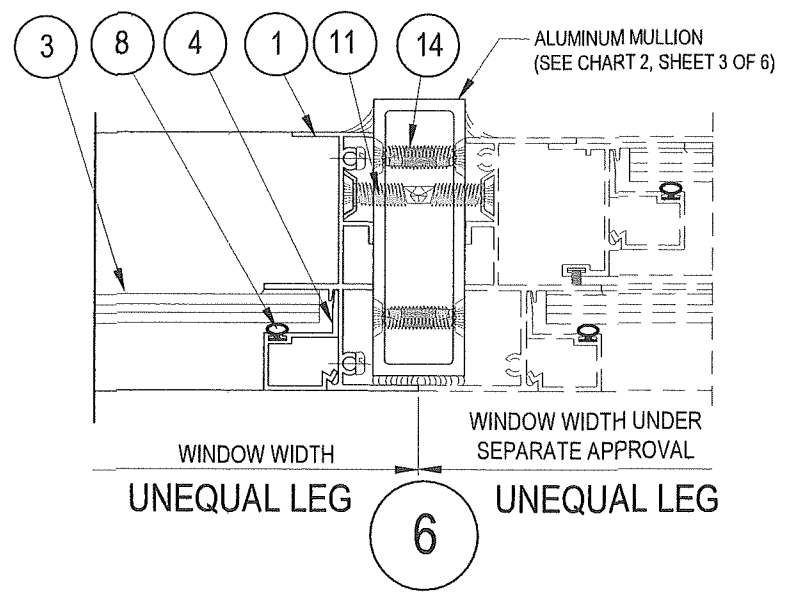

**6** UNEQUAL LEG

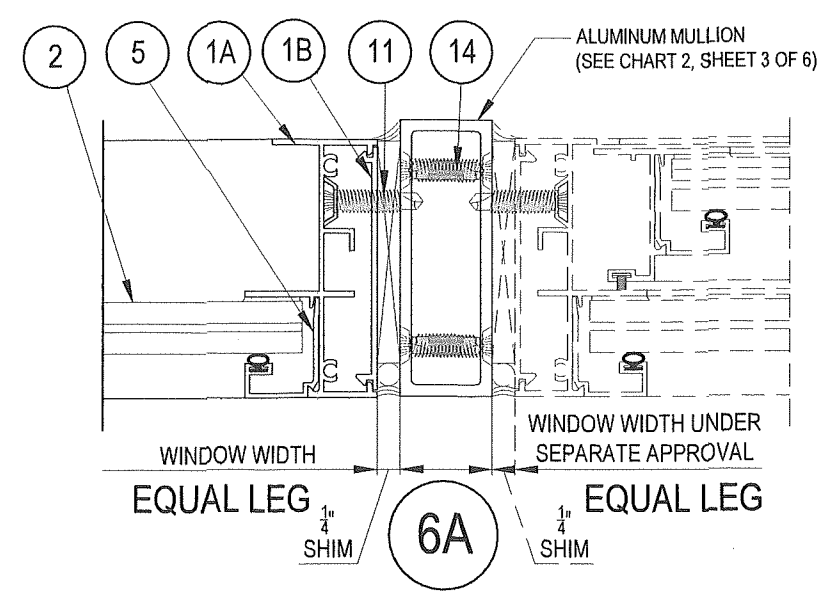

**6A** EQUAL LEG

**PRODUCT REVISED**  
 As complying with the Florida Building Code  
 NOA-No. **26-0311.05**  
 Expiration Date: **05/07/2030**  
 By: *Manuel Ferrer*  
 Miami-Dade Product Control

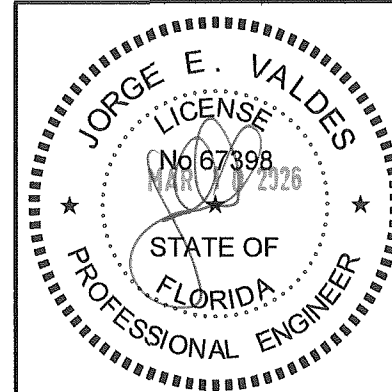

Miami Wall Systems, Inc.  
 701 West 25th Street  
 Hialeah, Florida, 33010  
 Phone: (305) 888-2300 Fax: (305) 888-3058

FIXED WINDOW 122 SERIES (LMI)  
 HORIZONTAL SECTIONS

NO.	DATE	REVISION
1	3/12/2020	UPDATE TO 2017 FBC
2	3/16/2021	UPDATE TO 2020 FBC
3	3/10/2026	UPDATE TO 2023 FBC

DATE: 10/15/2008  
 SCALE: AS NOTED  
 DWG. BY: L.R.A.  
 CHK. BY: JV  
 DWG NO.: 122-FIXED(LM)  
 SHEET 5 OF 6

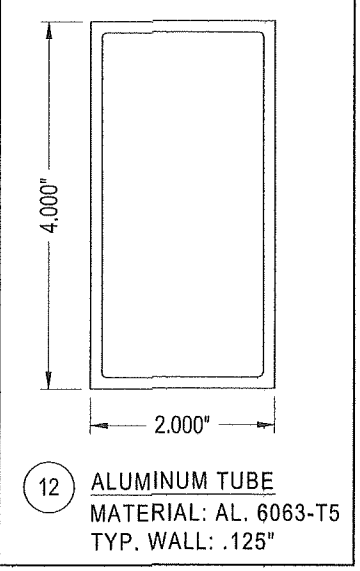
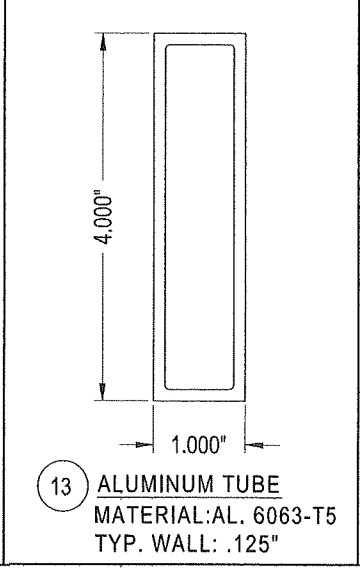
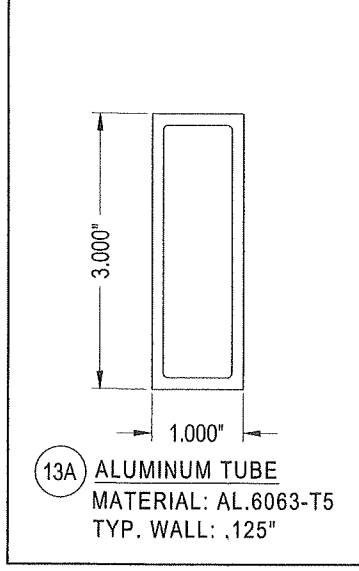
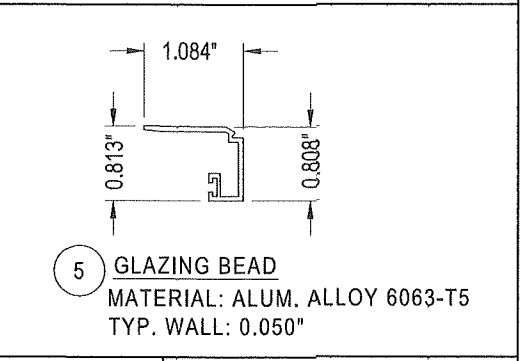
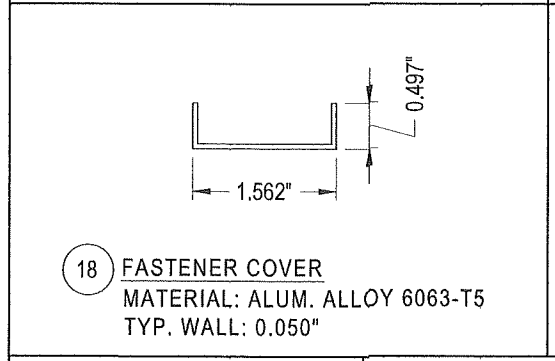
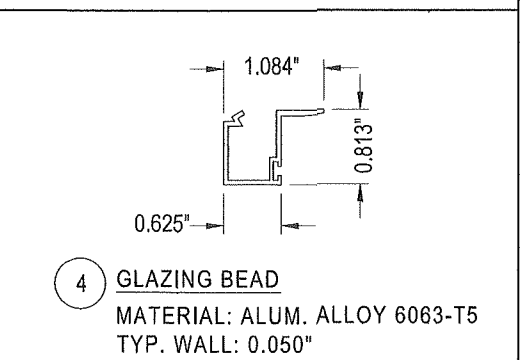
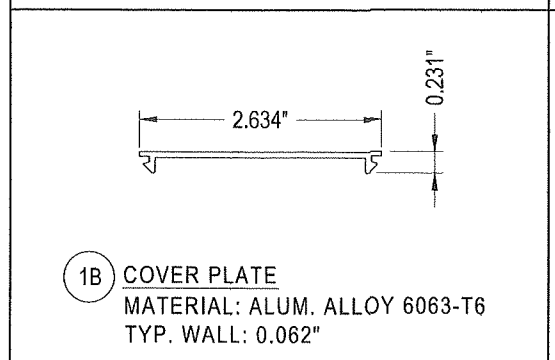
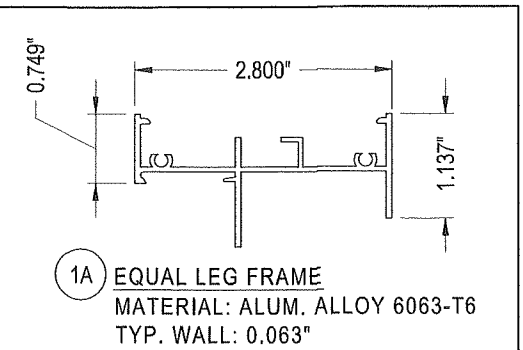
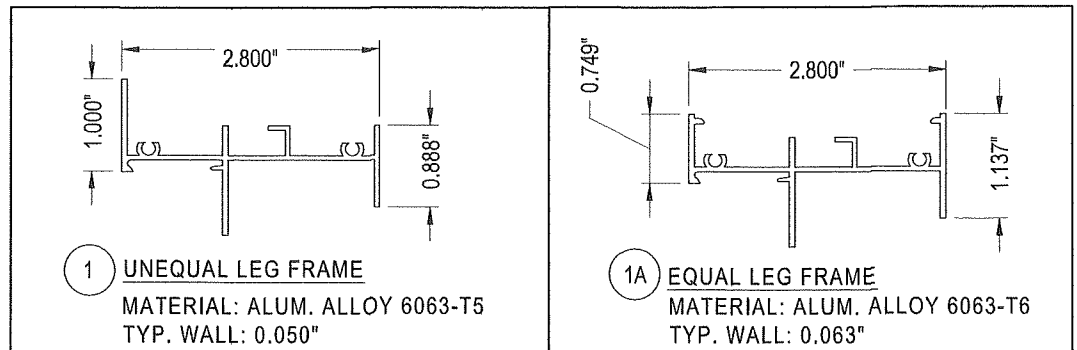

BILL OF MATERIALS				
ITEM	PART No.	REQUIRED	PART DESCRIPTION	REMARKS
1	122-001	4 PER LITE	UNEQUAL LEG FRAME	HEAD, SILL AND JAMBS
1A	122-110	4 PER LITE	EQUAL LEG FRAME	HEAD, SILL AND JAMBS
1B	122-111	4 PER LITE	COVER PLATE	USE WITH EQUAL LEG FRAME ONLY
2		1 PER WINDOW	9/16" LAMINATED GLASS	-
3		1 PER WINDOW	5/16" LAMINATED GLASS	-
4	122-008	4 PER LITE	EXTRUDED GLAZING BEAD	USE WITH 5/16" LAMINATED GLASS
5	122-010	4 PER LITE	EXTRUDED GLAZING BEAD	USE WITH 9/16" LAMINATED GLASS
6		8 PER LITE	FRAME ASSEMBLY SCREW	#8 x 1-1/4" PHP. P.H. SMS, S.STEEL
7		2 PER SILL	SETTING BLOCK (NEOPRENE)	1/8 x 1/4 x 4" LONG
8		AS REQ'D.	BULB VINYL	USE AT GLAZING BEAD PERIMETER
9		AS REQ'D.	GLAZING SILICONE	GE 4000, DOWSIL 995, GE 2800, TREMCO SPECTREM 2
10		SEE ELEV.	INSTALLATION FASTENER (SEE ELEV. FOR SPACING)	Ø1/4" PHP. F.H. KWIK CON-II BY HILTI
11		SEE ELEV.	JAMB TO MULLION INSTALLATION SCREW	#14 x 1-1/2" PHP. FH. TEK SCREW
12		-	2 x 4 x 1/8" THK. ALUMINUM TUBE	MULLION TYPE 3
13		-	1 x 4 x 1/8" THK. ALUMINUM TUBE	MULLION TYPE 2
13A		-	1 x 3 x 1/8" THK. ALUMINUM TUBE	MULLION TYPE 1
14		2 / CLIP	ANGLE CLIP TO MULLION ASSEMBLY SCREW	#14 x 3/4" PHP. FH. TEK SCREW
15		4 / MULLION	2 x 2 x 3-3/4 x 1/8" THK. ANGLE CLIP	USE FOR 2 x 4 x 1/8" (MULLION TYPE 2)
16		4 / MULLION	2 x 2 x 2-5/8 x 1/8" THK. ANGLE CLIP	USE FOR 1 x 3 x 1/8" (MULLION TYPE 1)
17		-	MULLION CLIP TO CONCRETE INSTALLATION FASTENER	Ø1/4" PHP. F.H. KWIK CON-II BY HILTI
18		4 PER LITE	INSTALLATION FASTENER COVER (ALUMINUM)	OPTIONAL

**PRODUCT REVISED**  
 As complying with the Florida Building Code  
 NOA-No. **26-0311.05**  
 Expiration Date: **05/07/2030**  
 By: *Manuel Perez*  
 Miami-Dade Product Control

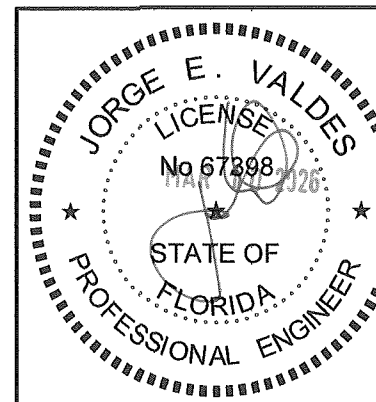

NO.	DATE	REVISION
1	3/12/2020	UPDATE TO 2017 FBC
2	3/16/2021	UPDATE TO 2020 FBC
3	3/10/2026	UPDATE TO 2023 FBC

DATE: 10/15/2008  
 SCALE: 1:2  
 DWG. BY: L.R.A.  
 CHK. BY: JV  
 DWG NO.: 122-FIXED(LM)  
 SHEET 6 OF 6

Miami Wall Systems, Inc.  
 701 West 25th Street  
 Hialeah, Florida. 33010  
 Phone: (305) 888-2300 Fax: (305) 888-3058

FIXED WINDOW 122 SERIES (LMI)  
 EXTRUSIONS  
 BILL OF MATERIALS