



**DEPARTMENT OF REGULATORY AND ECONOMIC RESOURCES (RER)
BOARD AND CODE ADMINISTRATION DIVISION
NOTICE OF ACCEPTANCE (NOA)**

**MIAMI-DADE COUNTY
PRODUCT CONTROL SECTION**
11805 SW 26 Street, Room 208
Miami, Florida 33175-2474
T (786) 315-2590 F (786) 315-2599
www.miamidade.gov/building

**Amarr Garage Doors dba Entrematic
165 Carriage Court
Winston Salem, NC 27105**

SCOPE:

This NOA is being issued under the applicable rules and regulations governing the use of construction materials. The documentation submitted has been reviewed and accepted by Miami-Dade County RER-Product Control Section to be used in Miami Dade County and other areas where allowed by the Authority Having Jurisdiction (AHJ).

This NOA shall not be valid after the expiration date stated below. The Miami-Dade County Product Control Section (In Miami Dade County) and/or the AHJ (in areas other than Miami Dade County) reserve the right to have this product or material tested for quality assurance purposes. If this product or material fails to perform in the accepted manner, the manufacturer will incur the expense of such testing and the AHJ may immediately revoke, modify, or suspend the use of such product or material within their jurisdiction. RER reserves the right to revoke this acceptance if it is determined by Miami-Dade County Product Control Section that this product or material fails to meet the requirements of the applicable building code.

This product is approved as described herein and has been designed to comply with the Florida Building Code, including the High Velocity Hurricane Zone.

DESCRIPTION: Model 500 Classica 1000, 2000 Steel Sectional Garage Door up to 16'-0" Wide-L.M.I

APPROVAL DOCUMENT: Drawing No. **IRC-5316-169-26-I**, titled "Model #500 Classica 1000 & 2000", sheets 1 through 3 of 3, dated 11/24/2020, prepared by manufacturer, signed and sealed by Thomas L. Shelmerdine, P.E. on 06/16/2021, bearing the Miami-Dade County Product Control Revision stamp with the Notice of Acceptance number and approval date by the Miami-Dade County Product Control Section.

MISSILE IMPACT RATING: Large and Small Missile Impact Resistant

LABELING: Each unit shall bear a permanent label with the manufacturer's name or logo, manufacturing address, model number, the positive and negative design pressure rating, indicate impact rated if applicable, installation instruction drawing reference number, approval number (NOA), the applicable test standards, and the statement reading 'Miami-Dade County Product Control Approved' is to be located on the door's side track, bottom angle, or inner surface of a panel.

RENEWAL of this NOA shall be considered after a renewal application has been filed and there has been no change in the applicable building code negatively affecting the performance of this product.

TERMINATION of this NOA will occur after the expiration date or if there has been a revision or change in the materials, use, and/or manufacture of the product or process. Misuse of this NOA as an endorsement of any product, for sales, advertising or any other purposes shall automatically terminate this NOA. Failure to comply with any section of this NOA shall be cause for termination and removal of NOA.

ADVERTISEMENT: The NOA number preceded by the words Miami-Dade County, Florida, and followed by the expiration date may be displayed in advertising literature. If any portion of the NOA is displayed, then it shall be done in its entirety.

INSPECTION: A copy of this entire NOA shall be provided to the user by the manufacturer or its distributors and shall be available for inspection at the job site at the request of the Building Official.

This NOA **renews # 23-1114.03** consists of this page 1 and evidence page E-1, and E-2, as well as approval document mentioned above.

The submitted documentation was reviewed by **Carlos Utrera, P.E.**



05/2026

NOA-No. 26-0430.04
Expiration Date: August 5, 2031
Approval Date: May 28, 2026
Page 1

NOTICE OF ACCEPTANCE: EVIDENCE SUBMITTED

A. DRAWINGS

1. Drawing No. **IRC-5316-169-26-I**, titled “Model #500 Classica 1000 & 2000”, sheets 1 through 3 of 3, dated 11/24/2020, prepared by manufacturer, signed and sealed by Thomas L. Shelmerdine, P.E. on 06/16/2021.

B. TESTS

1. Addendum letter to Test Report No. **ATLNC 0610.02-20**, dated 06/16/2021, signed and sealed by David W. Johnson, P.E.
2. Test reports on:
 - 1) Uniform Static Air Pressure Test, Loading per FBC, TAS 202-94
 - 2) Large Missile Impact Test per FBC, TAS 201-94
 - 3) Cyclic Wind Pressure Loading per FBC, TAS 203-94
 - 4) Forced Entry Test, TAS 202-94
 - 5) Tensile Test per ASTM E8along with installation diagram on Models 500 Steel Sectional Garage Doors, prepared by American Test Lab, Inc, Test Report No. **ATLNC 0610.02-20**, dated 12/15/2020, signed and sealed by David W. Johnson, P.E.
3. Test report on Salt Spray per ASTM D1654-08 and ASTM B117 of G-40 galvanized with polyester top coat, prepared by Intertek/ATI, Test Report No. **C5463.01-106-18**, dated 04/03/2013, signed by Joseph A. Reed, P.E. on 06/15/2017.

C. CALCULATIONS

1. Anchor calculations prepared by Structural Solutions, P.A., dated 03/15/2021, signed and sealed by Thomas L. Shelmerdine, P.E.

D. QUALITY ASSURANCE

1. Miami-Dade Department of Regulatory and Economic Resources (RER).

E. MATERIAL CERTIFICATIONS

1. None.

F. STATEMENTS

1. Statement letter of conformance, complying with FBC 7th Edition (2020) and of no financial interest, dated 03/15/2021, issued by Structural Solutions, P.A., signed and sealed by Thomas L. Shelmerdine, P.E.



A handwritten signature in blue ink, appearing to read "Carlos Utrera".

Carlos Utrera, P.E.
NOA No. 26-0430.04
Expiration Date: August 5, 2031
Approval Date: May 28, 2026

Amarr Garage Doors dba Entrematic

NOTICE OF ACCEPTANCE: EVIDENCE SUBMITTED

2. EVIDENCE SUBMITTED UNDER NOA–No. 23–1114.03

A. DRAWINGS

1. Drawing No. **IRC-5316-169-26-I**, titled “Model #500 Classica 1000 & 2000”, sheets 1 through 3 of 3, dated 11/24/2020, prepared by manufacturer, signed and sealed by Thomas L. Shelmerdine, P.E. on 06/16/2021.

B. TESTS

1. None.

C. CALCULATIONS

1. None.

D. QUALITY ASSURANCE

1. Miami-Dade Department of Regulatory and Economic Resources (RER).

E. MATERIAL CERTIFICATIONS

1. None.

F. STATEMENTS

1. Statement letter of conformance, complying with **FBC 8th Edition (2023)** and of no financial interest, dated 10/27/2023, issued by Structural Solutions, P.A., signed and sealed by Thomas L. Shelmerdine, P.E



A handwritten signature in blue ink, appearing to read "Carlos Utrera".

Carlos Utrera, P.E.
NOA No. 26-0430.04
Expiration Date: August 5, 2031
Approval Date: May 28, 2026

The following pages in this document were submitted by the manufacturer (third party) to represent the product being approved and establish the limits of use. The pages may include technical drawings, schematics and installation details.

LARGE MISSILE IMPACT RESISTANCE

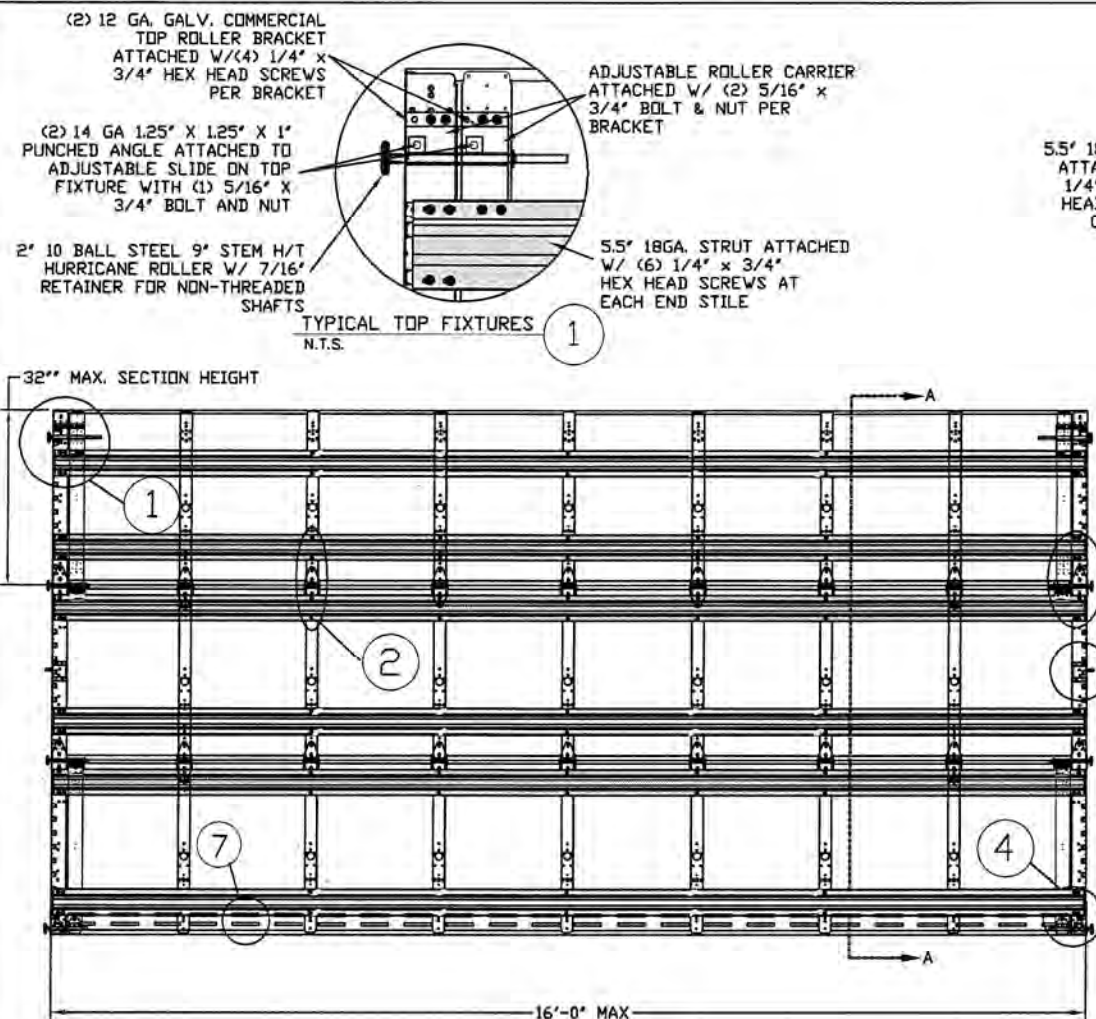

INSIDE ELEVATION
N.T.S.

PRODUCT RENEWED
as complying with the Florida
Building Code
NOA-No. 26-0430.04

Expiration Date 08/05/2031

By *[Signature]*
Miami-Dade Product Control

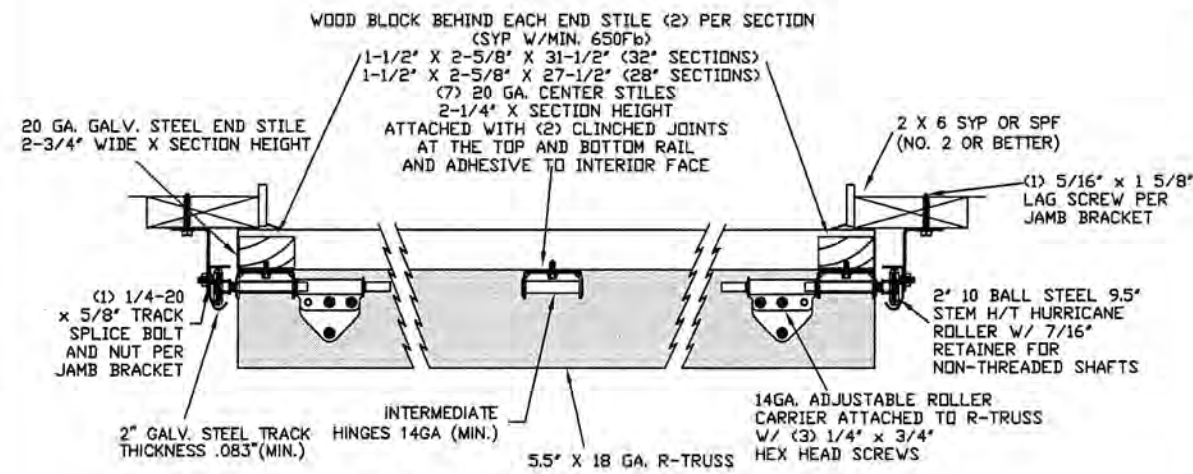

TRACK MOUNTING DETAIL
N.T.S.

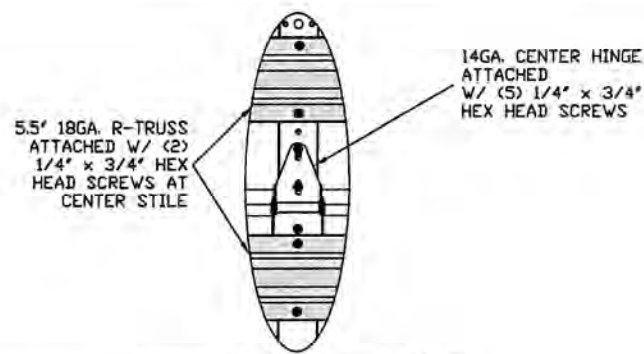

TYPICAL CENTER HINGE
N.T.S.

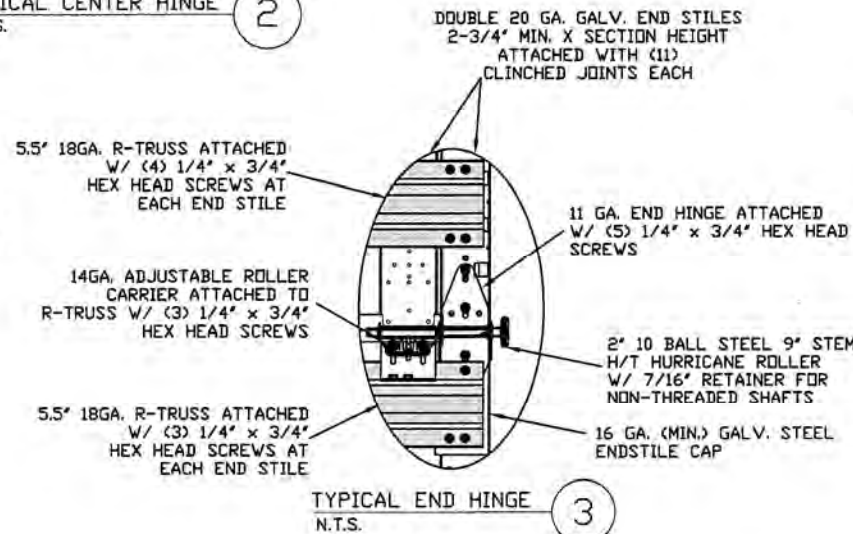

TYPICAL END HINGE
N.T.S.

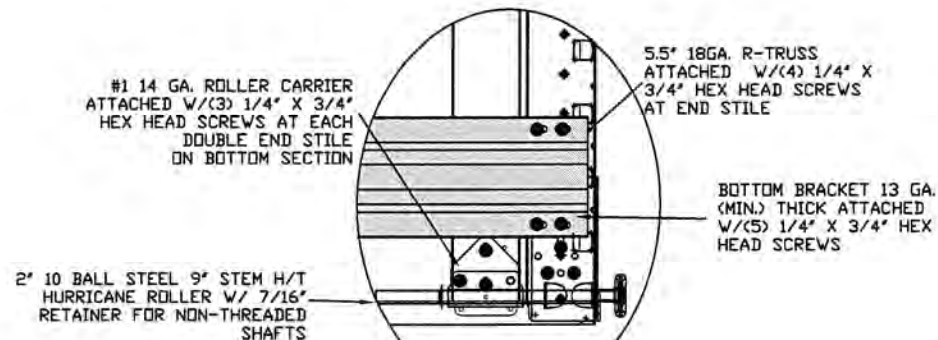

TYPICAL BOTTOM BRACKET
N.T.S.

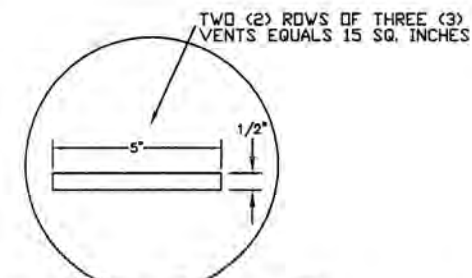

OPTIONAL VENT DETAIL
N.T.S.

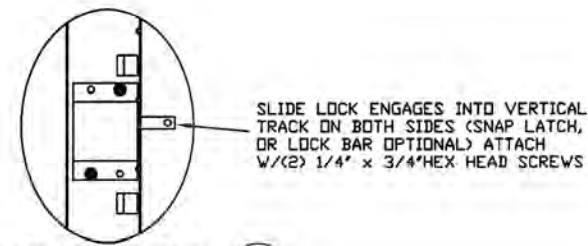

SLIDE LOCK DETAIL
N.T.S.

7" 16 GA. (MIN.) GALV. STEEL END STILE CAPS (TOP OF BOTTOM AND INTERMEDIATE SECTIONS)

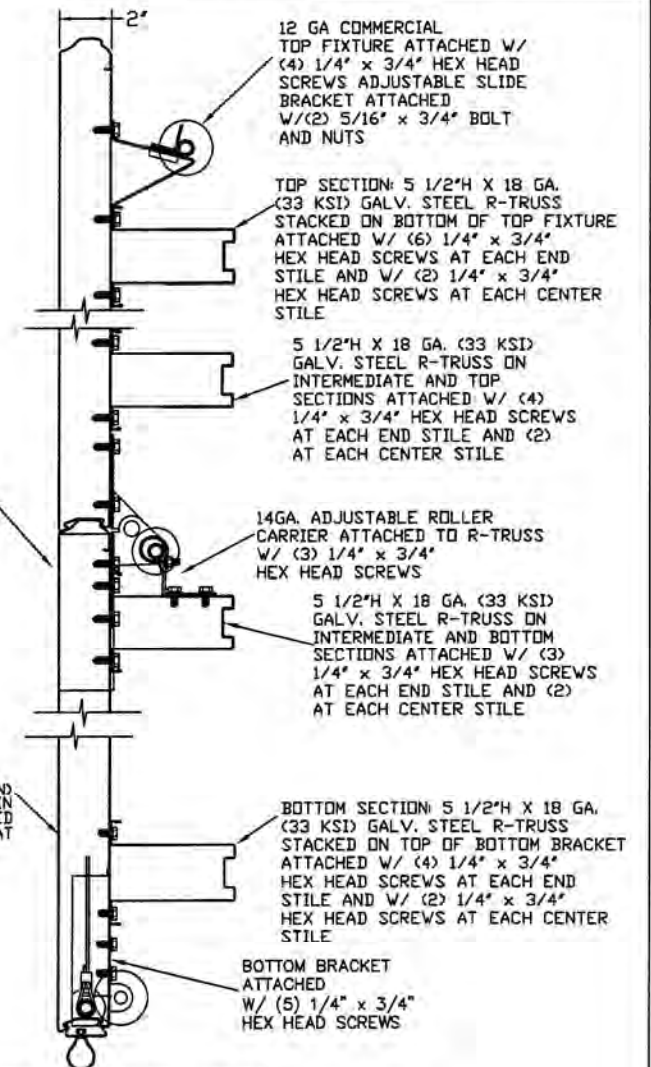

SECTION A-A (SIDE VIEW)
N.T.S.

REV	DESCRIPTION OF REVISIONS	DATE	BY
MAX SIZE	16' x 14'		
DESIGN LOADS	+43.3 PSF -49.3 PSF		
TEST LOADS (1.5 x DESIGN LOADS)	+65.0 PSF -74.0 PSF		
LARGE MISSILE IMPACT RESISTANCE			

Thomas L. Shelmerdine, PE (FL PE #0048579)
Structural Solutions, PA (FL Firm #29412)

dba Structural Solutions of North Carolina, Inc.
5921-G W. Friendly Ave., Greensboro, NC 27410

Amarr
ENTREMATIC

MODEL #500 AMARR CLASSICA 1000, 2000

SIZE	DRAWN BY	DLJ	DATE	11/05/2020	DRAWING NUMBER
B	CHECKED BY	DRC	DATE	11/24/2020	IRC-5316-169-26-1
ENTREMATIC 165 CARRIAGE COURT WINSTON-SALEM, N.C. 27105					SHEET 1 OF 3

14 GA. FLAG BRACKET ATTACHED TO WOOD JAMB/ (3) 5/16 DIA. X 1-5/8" LAG BOLTS AND TO TRACK W/ (4) 1/4"-20 X 5/8" TRACK SPLICE BOLTS AND NUTS

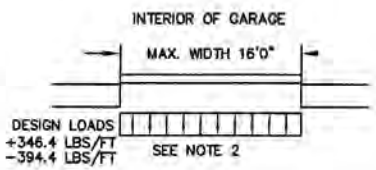
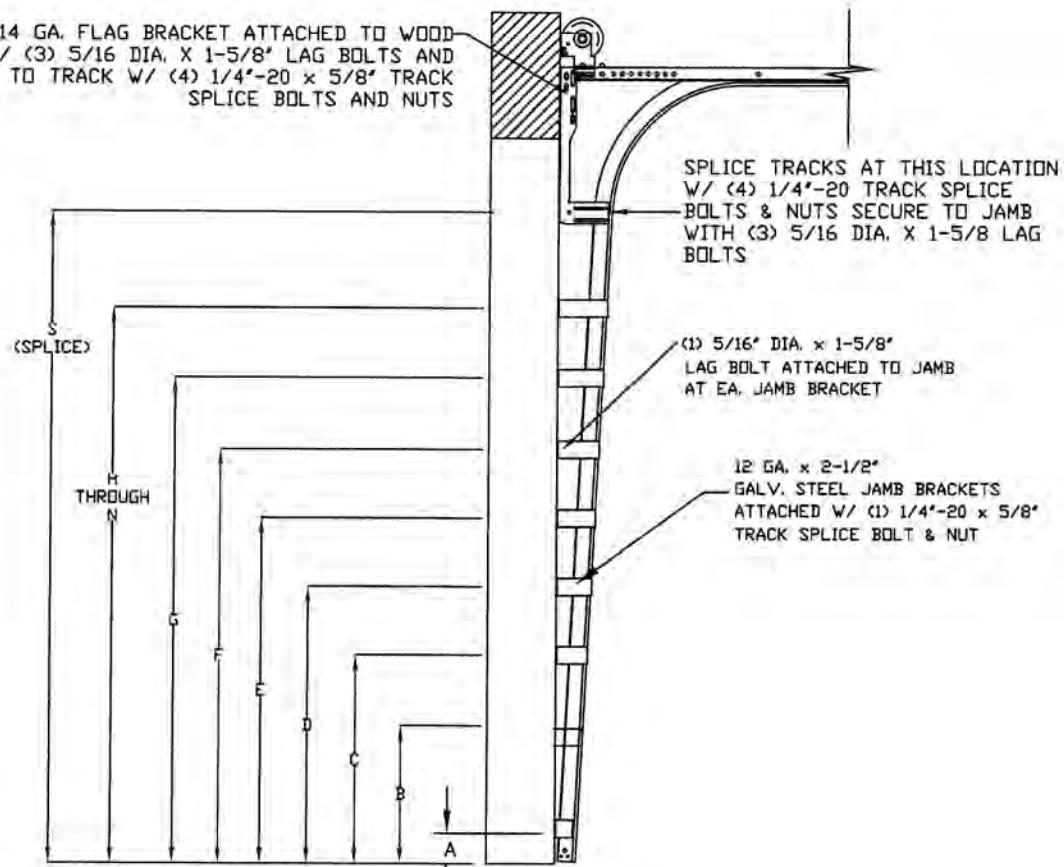

SPECIFICATIONS AND NOTES

1. ALL THE LOAD FROM THE DOOR IS TRANSFERRED TO THE VERTICAL TRACK, FROM THE TRACK THE LOAD IS TRANSFERRED TO THE VERTICAL JAMBS. THE HORIZONTAL JAMB OR HEADER RECEIVES NO PORTION OF THE LOAD TRANSFERRED FROM THE DOOR.
2. EACH VERTICAL JAMBS RECEIVES MAXIMUM DESIGN LOADS OF: +346.4 LBS/FT & -394.4 LBS/FT
3. DOORS AND HARDWARE WILL BE DESIGNED, MANUFACTURED AND INSTALLED WITH STANDARDS AS SET FORTH BY DASMA.
4. DOOR SECTIONS SHALL BE 24 GA. MIN. (.022") ROLLED FORMED, G30 GALVANIZED W/ POLYESTER TOP COAT
5. SUPPORTING STRUCTURAL ELEMENTS SHALL BE DESIGNED BY A REGISTERED PROFESSIONAL ENGINEER FOR WIND LOADS INDICATED ON THIS DRAWING IN ADDITION TO OTHER LOADINGS.
6. THIS APPROVAL REQUIRES THE MANUFACTURER TO DO TESTING OF ALL COILS USED TO FABRICATE DOOR PANELS UNDER THIS NOTICE OF ACCEPTANCE. A MINIMUM OF 2 SPECIMENS SHALL BE CUT FROM EACH COIL AND TENSILE TESTED ACCORDING TO ASTM E-8 BY A DADE COUNTY APPROVED LAB SELECTED AND PAID BY THE MANUFACTURER. EVERY 3 MONTHS, 4 TIMES A YEAR, THE MANUFACTURER SHALL MAIL TO THIS OFFICE: A COPY OF THE TEST REPORTS WITH CONFIRMATION THAT THE SPECIMENS WERE SELECTED FROM COILS AT THE MANUFACTURER PRODUCTION FACILITIES. AND A NOTARIZED STATEMENT FROM THE MANUFACTURER THAT ONLY COILS WITH YIELD STRENGTH OF 50,000 PSI OR MORE SHALL BE USED TO MAKE DOOR PANELS FOR DADE COUNTY UNDER THIS NOTICE OF ACCEPTANCE.

PRODUCT RENEWED
as complying with the Florida Building Code
NOA-No. 26-0430.04

Expiration Date 08/05/2031

By *[Signature]*
Miami-Dade Product Control

TOP FIXTURE REINFORCEMENT ILLUSTRATION

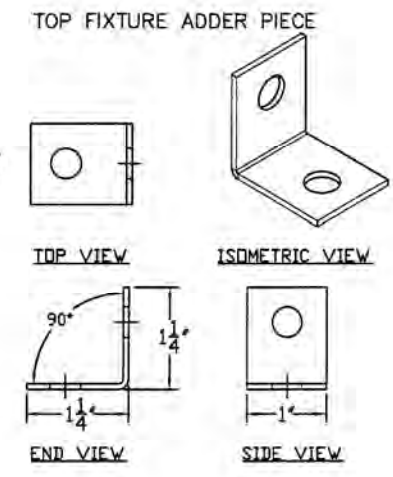
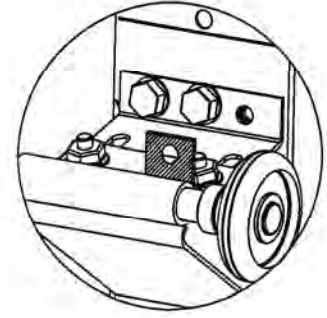

SEE (TABLE 3) FOR JAMB BRACKET SPACING

STANDARD TRACK CONFIGURATION FOR 7' AND 8' TALL DOORS
N.T.S.

WOOD JAMB ATTACHMENT TO STRUCTURE

- 2 X 6 VERTICAL JAMB ATTACHMENT TO WOOD FRAME STRUCTURE (G=0.42)
5/16" X 3" LAG SCREWS STARTING 6" FROM ENDS THEN 14" O.C. (1 1/2" EMBEDMENT)
- 2 X 6 VERTICAL JAMB ATTACHMENT TO 2,000 PSI CONCRETE
HILTI KWIK BOLT 3/8" X 4" STARTING 6" FROM ENDS THEN 24" O.C. (2 1/2" EMBEDMENT)
HILTI SLEEVE ANCHOR 3/8" X 2-3/4" STARTING 6" FROM ENDS THEN 12" O.C. (1 1/4" EMBEDMENT)
ITW/RAMSET REDHEAD (TRU-BOLT) 3/8" X 4" STARTING 6" FROM ENDS THEN 24" O.C. (2 1/2" EMBEDMENT)
- 2 X 6 VERTICAL JAMB ATTACHMENT TO HOLLOW C-90 BLOCK
SIMPSON 1/4" X 3" TITEN SCREWS STARTING 6" FROM ENDS, USE PAIRS OF FASTENERS (3" APART) AT 8" O.C. (1 1/2" EMBEDMENT)
HILTI 1/4" X 2-3/4" KWIK-CON II+ SCREWS STARTING 6" FROM ENDS, USE PAIRS OF FASTENERS (3" APART) AT 8" O.C. (1 1/4" EMBEDMENT)

- 2 X 6 VERTICAL JAMB ATTACHMENT TO GROUTED C-90 BLOCK (2000 PSI GROUT)
HILTI SLEEVE ANCHOR 3/8" X 2-3/4" STARTING 6" FROM ENDS THEN 14" O.C. (1 1/4" EMBEDMENT) (OR, USE FASTENERS FOR HOLLOW C-90 BLOCK)

*LAGS AND BOLTS CAN BE COUNTERSUNK TO PROVIDE A FLUSH MOUNTING SURFACE.
*PREPARATION OF WOOD JAMBS BY OTHERS

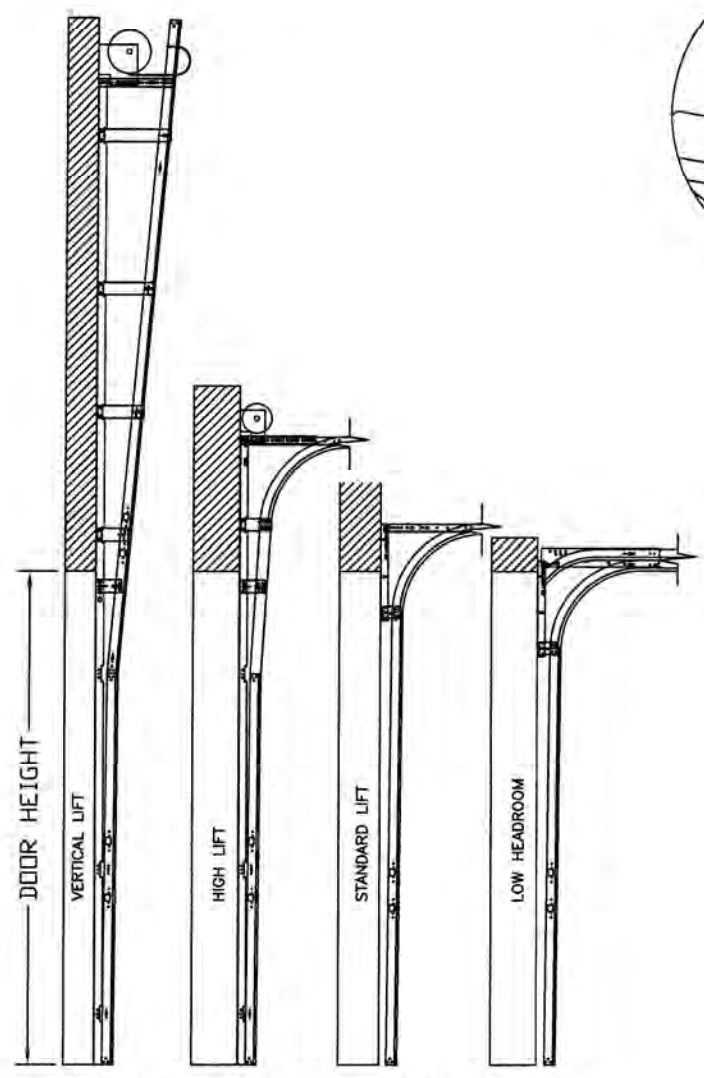
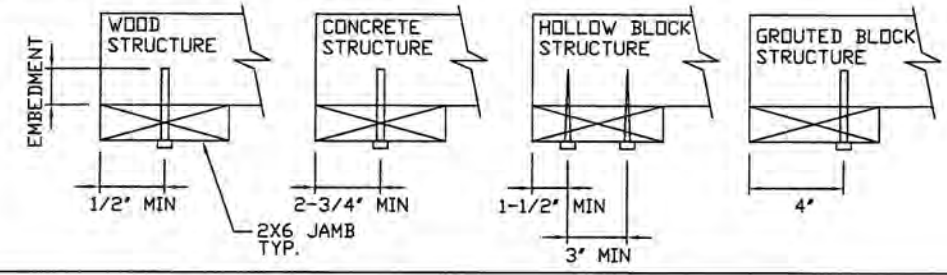

AVAILABLE TRACK CONFIGURATIONS
N.T.S.

REV	DESCRIPTION OF REVISIONS	DATE	BY

MAX SIZE 16' x 14'	DESIGN LOADS +43.3 PSF -49.3 PSF	TEST LOADS (1.5 x DESIGN LOADS) +65.0 PSF -74.0 PSF	LARGE MISSILE IMPACT RESISTANCE

Thomas L. Shelmerdine, PE (FL PE #00048579) Structural Solutions, PA (FL Firm #29412)		FL Amarr ENTREMATIC

FL

Thomas L. Shelmerdine, PE (FL PE #00048579)
Structural Solutions, PA (FL Firm #29412)

FL

Amarr
ENTREMATIC

MODEL #500 AMARR CLASSICA 1000, 2000

SIZE	DRAWN BY	DLJ	DATE	11/05/2020	DRAWING NUMBER
B	CHECKED BY	DRC	DATE	11/24/2020	IRC-5316-169-26-1
ENTREMATIC 165 CARRIAGE COURT WINSTON-SALEM, N.C. 27105					SHEET 2 OF 3

TABLE 1

Section	Center Stile Locations (Measured from Left Edge)						
	Width (ft)	1st (in)	2st (in)	3rd (in)	4th (in)	5th (in)	6th (in)
15' 6"	24.63	47.42	70.21	93.00	115.79	138.58	161.37
15' 8"	25.03	48.02	71.01	94.00	116.99	139.98	162.97
15' 10"	25.43	48.62	71.81	95.00	118.19	141.38	164.57
16' 0"	24.63	48.42	72.21	96.00	119.79	143.58	167.37

TABLE 2

SECTION	STRUT SIZE
TOP	5.5"
	5.5"
5TH	5.5"
	5.5"
4TH	5.5"
	5.5"
3RD	5.5"
	5.5"
2ND	5.5"
	5.5"
BOTTOM	5.5"
	5.5"



PRODUCT RENEWED
 as complying with the Florida
 Building Code
 NOA-No. 26-0430.04
 Expiration Date 08/05/2031
 By 
 Miami-Dade Product Control

TABLE 3

DOOR HEIGHT	TRACK ATTACHMENT														TYPICAL SPLICE
	A	B	C	D	E	F	G	H	I	J	K	L	M	N	
7' 0"	3.5"	10.0"	22.0"	34"	46"	58"	70"								76"
7' 6"	3.5"	10.0"	22.0"	34"	46"	58"	70"								82"
8' 0"	3.5"	10.0"	22.0"	34"	46"	58"	70"	82"							88"
8' 6"	3.5"	10.0"	22.0"	34"	46"	58"	70"	82"							94"
9' 0"	3.5"	10.0"	22.0"	34"	46"	58"	70"	82"	94"						100"
9' 6"	3.5"	10.0"	22.0"	34"	46"	58"	70"	82"	94"						106"
10' 0"	3.5"	10.0"	22.0"	34"	46"	58"	70"	82"	94"	106"					112"
11' 0"	3.5"	10.0"	22.0"	34"	46"	58"	70"	82"	94"	106"	118"				124"
12' 0"	3.5"	10.0"	22.0"	34"	46"	58"	70"	82"	94"	106"	118"	130"			136"
13' 0"	3.5"	10.0"	22.0"	34"	46"	58"	70"	82"	94"	106"	118"	130"	142"		148"
14' 0"	3.5"	10.0"	22.0"	34"	46"	58"	70"	82"	94"	106"	118"	130"	142"	154"	160"

ALL TRACK AND ATTACHMENT SPACING +/-2"
 ALLOWED WITH SYP OR SPF NO. 2 OR BETTER ONLY

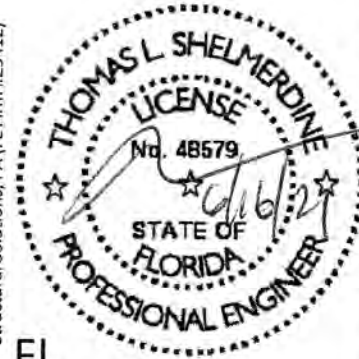
REV	DESCRIPTION OF REVISIONS	DATE	BY
	MAX SIZE 16' x 14' DESIGN LOADS +43.3 PSF -49.3 PSF TEST LOADS (1.5 x DESIGN LOADS) +65.0 PSF -74.0 PSF LARGE MISSILE IMPACT RESISTANCE		
	 Thomas L. Shelmerdine, PE (FL PE #0048579) Structural Solutions, PA (FL Firm #29412) FL dba Structural Solutions of North Carolina, Inc. 5921-G.W. Friendly Ave., Greensboro, NC 27410		
			
	MODEL #500 AMARR CLASSICA 1000, 2000		
SIZE	DRAWN BY DLJ	DATE 11/05/2020	DRAWING NUMBER
B	CHECKED BY DRC	DATE 11/24/2020	IRC-5316-169-26-1
	ENTREMATIC 165 CARRIAGE COURT WINSTON-SALEM, N.C. 27105		SHEET 3 OF 3