



**BUILDING CODE COMPLIANCE OFFICE (BCCO)
PRODUCT CONTROL DIVISION**

**MIAMI-DADE COUNTY, FLORIDA
METRO-DADE FLAGLER BUILDING
140 WEST FLAGLER STREET, SUITE 1603
MIAMI, FLORIDA 33130-1563
(305) 375-2901 FAX (305) 375-2908**

NOTICE OF ACCEPTANCE (NOA)

**Monier Lifetile, LLC.
7575 Irvine Center Drive, Suite 100
Irvine, CA. 92618**

SCOPE:

This NOA is being issued under the applicable rules and regulations governing the use of construction materials. The documentation submitted has been reviewed by Miami-Dade County Product Control Division and accepted by the Board of Rules and Appeals (BORA) to be used in Miami Dade County and other areas where allowed by the Authority Having Jurisdiction (AHJ).

This NOA shall not be valid after the expiration date stated below. The Miami-Dade County Product Control Division (In Miami Dade County) and/or the AHJ (in areas other than Miami Dade County) reserve the right to have this product or material tested for quality assurance purposes. If this product or material fails to perform in the accepted manner, the manufacturer will incur the expense of such testing and the AHJ may immediately revoke, modify, or suspend the use of such product or material within their jurisdiction. BORA reserves the right to revoke this acceptance, if it is determined by Miami-Dade County Product Control Division that this product or material fails to meet the requirements of the applicable building code.

This product is approved as described herein, and has been designed to comply with the Florida Building Code, including the High Velocity Hurricane Zone of the Florida Building Code.

DESCRIPTION: Elevated Batten System (EBS)

LABELING: Each unit shall bear a permanent label with the manufacturer's name or logo, city, state and following statement: "Miami-Dade County Product Control Approved", unless otherwise noted herein.

RENEWAL of this NOA shall be considered after a renewal application has been filed and there has been no change in the applicable building code negatively affecting the performance of this product.

TERMINATION of this NOA will occur after the expiration date or if there has been a revision or change in the materials, use, and/or manufacture of the product or process. Misuse of this NOA as an endorsement of any product, for sales, advertising or any other purposes shall automatically terminate this NOA. Failure to comply with any section of this NOA shall be cause for termination and removal of NOA.

ADVERTISEMENT: The NOA number preceded by the words Miami-Dade County, Florida, and followed by the expiration date may be displayed in advertising literature. If any portion of the NOA is displayed, then it shall be done in its entirety.

INSPECTION: A copy of this entire NOA shall be provided to the user by the manufacturer or its distributors and shall be available for inspection at the job site at the request of the Building Official.

This NOA consists of pages 1 through 4.
The submitted documentation was reviewed by Alex Tigera.



**NOA No.: 09-0127.05
Expiration Date: 05/06/14
Approval Date: 05/06/09**

ROOFING COMPONENT APPROVAL

<u>Category:</u>	Roofing
<u>Sub-Category:</u>	Other
<u>Materials</u>	Wood/Plastic

1. SCOPE

This approves the Elevated Batten System (EBS) as manufactured by Bowers Forest Products Corp. in Estacada, OR. And distributed by Monier Lifetile LLC. as described in Section 2 of this Notice of Acceptance.

2. PRODUCT DESCRIPTION

<u>Product</u>	<u>Dimensions</u>	<u>Test Specifications</u>	<u>Product Description</u>
Elevated Batten System (EBS)	1" x 2" x 4' 1" x 2" x 8'	ASTM D 2843 ASTM D 635 ASTM D 1929	Anti fungus/anti mold treated construction grade or better Douglas Fir, upgraded for wane, splits and knots; with integrated 3/8" diameter polyethylene plastic pads or plywood pads spaced 12" o.c.
Elevated Batten System (EBS)	1" x 3" x 4' 1" x 3" x 8'	ASTM D 2843 ASTM D 635 ASTM D 1929	Anti fungus/anti mold treated construction grade or better Douglas Fir, upgraded for wane, splits and knots; with integrated 3/8" diameter polyethylene plastic pads or plywood pads spaced 12" o.c.
Elevated Batten System (EBS)	1" x 3" x 8'	ASTM D 2843 ASTM D 635 ASTM D 1929	Pressure treated construction grade or better Douglas Fir, upgraded for wane, splits and knots; with integrated 3/8" diameter polyethylene plastic pads or plywood pads spaced 12" o.c.
Elevated Batten System (EBS)	1" x 3" x 8'	ASTM D 2843 ASTM D 635 ASTM D 1929	Fire retardant treated construction grade or better Douglas Fir, upgraded for wane, splits and knots; with plywood pads spaced 12" o.c.



NOA No.: 09-0127.05
Expiration Date: 05/06/14
Approval Date: 05/06/09

3. EVIDENCE SUBMITTED:

<u>Test Agency</u>	<u>Test Identifier</u>	<u>Test Name/Report</u>	<u>Date</u>
ETC Laboratories	ETC-08-718-21936.0	ASTM D 1929	12/02/08
ETC Laboratories	ETC-08-718-21936.0	ASTM D 2843	12/02/08
ETC Laboratories	ETC-08-718-21936.0	ASTM D 635	12/02/08

4. LIMITATIONS

- 4.1 Fire classification is not part of this acceptance; refer to a current Approved Roofing Materials Directory for fire ratings of this product.
- 4.2 Elevated Batten System (EBS) may be used with any approved roof covering listing the Elevated Batten System (EBS) as a component part of an assembly in the Notice of Acceptance. If Elevated Batten System (EBS) is not listed, a request may be made to the Authority Having Jurisdiction (AHJ) or the Miami Dade County Product Control Department for approval, provided that appropriate documentation is provided to detail compatibility of the products, wind uplift resistance, and fire testing results.
- 4.3 All products listed herein shall have a quality assurance audit in accordance with the Florida Building Code and Rule 9B-72 of the Florida Administrative Code.

5. INSTALLATION

- 5.1 This product is to be installed as specified in RAS-118 and RAS-119 and all applicable Building Code requirements.

6. LABELING

- 6.1 Elevated Batten System shall be labeled with the manufactures name or logo and the Miami-Dade Product Control Approved Seal as seen below or the wording "Miami-Dade County Product Control Approved".



7. BUILDING PERMIT REQUIREMENTS

- 7.1 Application for building permit shall be accompanied by copies of the following:
 - 7.1.1 This Notice of Acceptance.
 - 7.1.2 Any other documents required by the Building Official or the applicable code in order to properly evaluate the installation of this component.



NOA No.: 09-0127.05
Expiration Date: 05/06/14
Approval Date: 05/06/09

DETAIL A

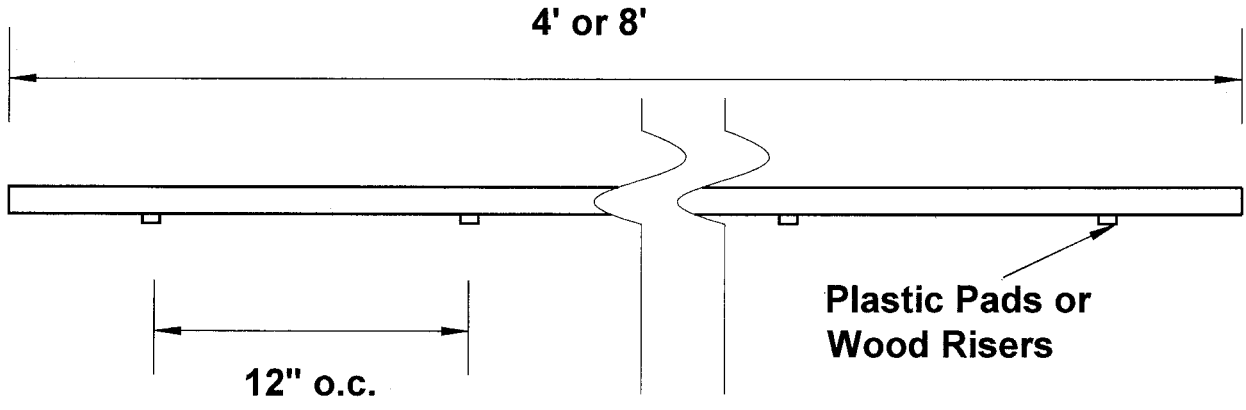

END OF THIS ACCEPTANCE

