

# Memorandum



**Date:** March 4, 2014

Agenda Item No. 8(J)(1)

**To:** Honorable Chairwoman Rebeca Sosa  
and Members, Board of County Commissioners

**From:** Carlos A. Gimenez  
Mayor

**Subject:** Railroad Reimbursement Agreements between Miami-Dade County, the Florida Department of Transportation and the Florida East Coast Railway, L.L.C.

## **RECOMMENDATION**

It is recommended that the Board approve the two attached Railroad Reimbursement Agreements for Grade Crossing Traffic Control Devices between Miami-Dade County ("County"), the Florida Department of Transportation ("FDOT"), and the Florida East Coast Railway, L.L.C. ("FEC"). These Reimbursement Agreements will allow the FEC to furnish and install two (2) Automatic Grade Crossing Signals and other associated traffic control devices on Dodge Island at the at-grade railroad tracks crossing two public roadways, (Caribbean Way East and Caribbean Way West). The FDOT shall reimburse the FEC for all costs associated with the construction of all traffic control devices at these two crossings. After installation of these signals is completed, the FEC will service, operate and maintain the on-port crossings, and the County will be responsible for reimbursing the FEC for the annual maintenance costs as stipulated in the Schedule of Annual Cost of Automatic Highway Grade Crossing Devices in the Reimbursement Agreements.

## **SCOPE**

PortMiami ("Port") is located within District 5 – Commissioner Bruno A. Barreiro. The impact of this agenda item is countywide as the Port is a regional asset and generates employment for residents throughout Miami-Dade County. The on-Port, at-grade railroad tracks and associated right-of-way on Dodge Island within the project limits are fully owned by the County.

## **FISCAL IMPACT/FUNDING SOURCE**

The project cost to install the automatic grade crossings signals and associated traffic control devices at Caribbean Way East and Caribbean Way West is estimated by the FEC at \$360,010 and \$333,480, respectively. Per the Reimbursement Agreements, the FEC shall furnish and install all equipment on an actual cost basis, and the FDOT shall reimburse the FEC for all costs incurred in the installation of these facilities. There is no fiscal impact to the County for the costs of construction of these railroad crossing facilities. However, the County will be responsible for all future maintenance expenses, currently capped at an annual cost of \$6,726 per each railroad crossing at Caribbean Way East and Caribbean Way West, for a total annual maintenance cost of \$13,452. These costs are enumerated in the Schedule of Annual Cost of Automatic Highway Grade Crossing Devices under the authority of the Florida Administrative Rule 14-57.011 Public Railroad- Highway Grade Crossing Costs, as attached to the Reimbursement Agreements. The current schedule became effective on July 1, 2011, and is reviewed every 5 years and revised as appropriate

based on the Consumer Price Index for all Urban Consumers published by the U.S. Department of Labor. The funding for this project will be paid by Seaport Revenues.

**TRACK RECORD/MONITOR**

Port staff members responsible for monitoring these agreements are Juan Kuryla, Director Designee, and Kevin Lynskey, Assistant Director for Business Initiatives.

**BACKGROUND**

The Port is undergoing its most significant cargo facility expansion in 30 years, putting in place three critical pieces of infrastructure that are timed with - and in anticipation of - the Panama Canal expansion. These assets all revolve around access: deeper waters to accommodate a new Post-Panamax class of mega-container vessel; twin tunnels to provide direct highway access; and an on-dock intermodal rail system to facilitate the movement of goods to distant markets. PortMiami's intermodal and rail reconnection project was developed jointly with the FEC and resulted in a successful 2010 U.S Department of Transportation TIGER II Grant. The project entails approximately \$49M in investment in on-Port (\$25M) and off-Port (\$24M) improvements. The Tiger II Grant was made available to cover the costs of the on-Port Railroad bridge rehabilitation, upgrade to the mainline access tracks, and the implementation of the on-dock rail intermodal yard.

To support the expected increase in rail movement accessing the rail intermodal yard, there is a need to upgrade and add active advance warning devices, associated traffic control devices, and railroad crossing pavement markings to the two existing at-grade highway railroad crossings on Port at the Caribbean Way East and Caribbean Way West intersections in order to enhance safety as the FEC moves cargo to and from the Port. FDOT has agreed to provide the funds required for the FEC to develop and implement the automatic grade crossing signals and support traffic control devices project on these County-owned facilities under the State's Highway-Rail Grade Crossing Safety Improvement Program. Board approval of these two tri-party Reimbursement Agreements will allow the FEC to move forward with the development and implementation of the highway-railroad crossing upgrades to Caribbean Way East and West with the FDOT reimbursing the FEC for all implementation costs upon final approval of all goods and services, and will direct the County to establish an annual maintenance payment schedule as enumerated in the Schedule of Annual Cost of Automatic Highway Grade Crossing Devices for the reimbursement to the FEC for the costs incurred during the annual maintenance of the highway rail crossings.

**DELEGATED AUTHORITY**

In accordance with Section 2-8.3 of the Miami-Dade County Code related to identifying delegation of Board authority, there are no authorities beyond those specific in the resolution which include the authority for the Mayor or designee to execute the Agree and to exercise any cancellation or renewal provisions.

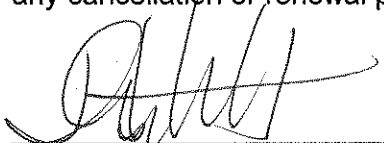
  
\_\_\_\_\_  
Jack Osterholt, Deputy Mayor



# MEMORANDUM

(Revised)

**TO:** Honorable Chairwoman Rebeca Sosa  
and Members, Board of County Commissioners

**DATE:** March 4, 2014

**FROM:**   
R. A. Cuevas, Jr.  
County Attorney

**SUBJECT:** Agenda Item No. 8(J)(1)

Please note any items checked.

- "3-Day Rule" for committees applicable if raised
- 6 weeks required between first reading and public hearing
- 4 weeks notification to municipal officials required prior to public hearing
- Decreases revenues or increases expenditures without balancing budget
- Budget required
- Statement of fiscal impact required
- Ordinance creating a new board requires detailed County Mayor's report for public hearing
- No committee review
- Applicable legislation requires more than a majority vote (i.e., 2/3's \_\_\_\_\_, 3/5's \_\_\_\_\_, unanimous \_\_\_\_\_) to approve
- Current information regarding funding source, index code and available balance, and available capacity (if debt is contemplated) required

Approved \_\_\_\_\_ Mayor  
Veto \_\_\_\_\_  
Override \_\_\_\_\_

Agenda Item No. 8(J)(1)

3-4-14

RESOLUTION NO. \_\_\_\_\_

RESOLUTION APPROVING THE EXECUTION OF TWO RAILROAD REIMBURSEMENT AGREEMENTS FOR GRADE CROSSING TRAFFIC CONTROL DEVICES BETWEEN MIAMI-DADE COUNTY, THE FLORIDA DEPARTMENT OF TRANSPORTATION, AND THE FLORIDA EAST COAST RAILWAY, LLC FOR GRADE CROSSINGS AT EAST AND WEST CARIBBEAN WAY ON THE PORT OF MIAMI FOR AN ESTIMATED TOTAL ANNUAL MAINTENANCE COST OF \$13,452.00

**WHEREAS**, this Board desires to accomplish the purposes outlined in the accompanying memorandum, a copy of which is incorporated herein by reference,

**NOW, THEREFORE, BE IT RESOLVED BY THE BOARD OF COUNTY COMMISSIONERS OF MIAMI-DADE COUNTY, FLORIDA**, that this Board approves the two (2) Railroad Reimbursement Agreements – Grade Crossing Traffic Control Devices between the County, the State of Florida Department of Transportation, and the Florida East Coast Railway, L.L.C. (“Reimbursement Agreements”) in substantially the form attached hereto and made a part hereof and authorizes the Mayor or the Mayor’s designee to execute the two Reimbursement Agreements for and on behalf of Miami-Dade County.

The foregoing resolution was offered by Commissioner \_\_\_\_\_, who moved its adoption. The motion was seconded by Commissioner \_\_\_\_\_ and upon being put to a vote, the vote was as follows:

Rebeca Sosa, Chairwoman  
Lynda Bell, Vice Chair

Bruno A. Barreiro  
Jose "Pepe" Diaz  
Sally A. Heyman  
Jean Monestime  
Sen. Javier D. Souto  
Juan C. Zapata

Esteban L. Bovo, Jr.  
Audrey M. Edmonson  
Barbara J. Jordan  
Dennis C. Moss  
Xavier L. Suarez

The Chairperson thereupon declared the resolution duly passed and adopted this 4<sup>th</sup> day of March, 2014. This resolution shall become effective ten (10) days after the date of its adoption unless vetoed by the Mayor, and if vetoed, shall become effective only upon an override by this Board.

MIAMI-DADE COUNTY, FLORIDA  
BY ITS BOARD OF  
COUNTY COMMISSIONERS

HARVEY RUVIN, CLERK

By: \_\_\_\_\_  
Deputy Clerk

Approved by County Attorney as  
to form and legal sufficiency.



Richard Seavey

STATE OF FLORIDA DEPARTMENT OF TRANSPORTATION  
**RAILROAD REIMBURSEMENT AGREEMENT**  
**GRADE CROSSING TRAFFIC CONTROL DEVICES - COUNTY**

725-090-27  
 RAIL  
 OGC - 04/12

FINANCIAL PROJECT NO.	ROAD NAME OR NUMBER	COUNTY NAME	PARCEL & R/W NUMBER	FAP NUMBER
43329715701	Caribbean Way East	MIAMI-DADE	1(SIG-B)	N/A

THIS AGREEMENT, made and entered into this \_\_\_\_\_ day of \_\_\_\_\_, by and between the STATE OF FLORIDA DEPARTMENT OF TRANSPORTATION, hereinafter called the DEPARTMENT, and Florida East Coast Railway Company, a corporation organized and existing under the laws of Florida with its principal place of business in the City of Jacksonville, County of Duval State of Florida, hereinafter called the COMPANY; and Miami-Dade County, a political subdivision of the State of Florida, acting by and through its Board of County Commissioners, hereinafter called the COUNTY.

WITNESSETH:

WHEREAS, the DEPARTMENT is constructing, reconstructing or otherwise changing a portion of the Public Road System, designated by the Financial Project ID 43329715701, on Caribbean Way East, which crosses at grade the right of way and tracks of the COMPANY'S Milepost PL 5+4310', FDOT/AAR Crossing Number 273141M, at or near Caribbean Way East, as shown on DEPARTMENT'S Plan Sheet No. N/A, attached hereto as a part hereof; and

NOW, THEREFORE, in consideration of the mutual undertakings as herein set forth, the parties hereto agree as follows:

1. The COMPANY shall furnish the necessary materials and install Automatic Grade Crossing Signals Type 4 Class 3 and/or other traffic control devices at said location on an actual cost basis and in accordance with (1) the attached detailed statement of the work, plans, and specifications; and (2) the DEPARTMENT'S Plans and Standard Index Number 17882 attached hereto and made a part hereof.
2. After installation of said signals is completed, <sup>100%</sup> ~~fifty (50%)~~ percent of the expense thereof in maintaining the same shall be borne by the COUNTY and <sup>JS</sup> ~~fifty (50%)~~ percent shall be borne by the COMPANY, as enumerated by the Schedule of Annual Cost of Automatic Highway Grade Crossing Devices attached hereto and by this reference made a part hereof and subject to future revision.
3. After said signals have been installed and found to be in satisfactory working order by the parties hereto, the same shall be immediately put into service, operated and maintained by the COMPANY so long as said COMPANY or its successors or assigns shall operate the said signals at said grade crossing; or until it is agreed between the parties hereto that the signals are no longer necessary or until the said crossing is abandoned; or legal requirements occur which shall cease operation of signals thereat.

The COMPANY agrees that any future relocation or adjustment of said signals shall be performed by the COMPANY, but at the expense of the party initiating such relocation. Upon relocation the maintenance responsibilities shall be in accordance with the provisions of this agreement. It is further agreed that the cost of maintaining any additional or replacement signal equipment at the same location will be shared as provided under Paragraph 2. above.

4. Unless otherwise agreed upon herein, the COUNTY agrees to ensure that at the crossing the advance warning signs and railroad crossing pavement markings will conform to the U.S. Department of Transportation Manual on Uniform Traffic Control Devices within 30 days of notification that the railroad signal improvements have been completed and that such signs and pavement markings will be continually maintained at an acceptable level.

5. The COMPANY hereby agrees to install and/or adjust the necessary parts of its facilities along said road in accordance with the provisions set forth in the:

- (a) DEPARTMENT Procedure No. 725-080-002 Appendix D.4, and Rule 14.57.011 "Public Railroad-Highway Grade Crossing Costs", Florida Administrative Code.
- (b) Federal Highway Administration Federal-Aid Policy Guide, 23 C.F.R. Subchapter G, Part 646, Subpart B, and 23 C.F.R., Subchapter B, Part 140, Subpart I,

and any supplements thereto or revisions thereof, which, by reference hereto, are made a part hereof. The COMPANY further agrees to do all of such work, with its own forces or by a contractor paid under a contract let by the COMPANY, all under the supervision and approval of the DEPARTMENT and the Federal Highway Administration, when applicable.

6. The DEPARTMENT hereby agrees to reimburse the COMPANY for all costs incurred by it in the installation and/or adjustment of said facilities, in accordance with the provisions of Procedure No. 725-080-002 Appendix D-4 "Billing Requirements," and any supplements thereto or revisions thereof. It is understood and agreed by and between the parties hereto that preliminary engineering costs not incorporated within this agreement shall not be subject to payment by the DEPARTMENT.

7. Attached hereto, and by this reference made a part hereof, are plans and specifications of the work to be performed by the COMPANY pursuant to the terms hereof, and an itemized estimate of the cost thereof in the amount of \$ 360,010.00 . All work performed by the COMPANY pursuant hereto, shall be performed according to these plans and specifications as approved by the DEPARTMENT and the Federal Highway Administration if federal aid participating; and all subsequent plan changes shall likewise be approved by the DEPARTMENT and the Federal Highway Administration, when applicable.

8. All labor, services, materials, and equipment furnished by the COMPANY in carrying out the work to be performed hereunder shall be billed by the COMPANY direct to the DEPARTMENT. Separate records as to the costs of

contract bid items and force account items performed for the COMPANY shall also be furnished by the COMPANY to the DEPARTMENT.

9. The COMPANY has determined that the method to be used in developing the relocation or installation cost shall be as specified for the method checked and described hereafter:

- (a) Actual and related indirect costs accumulated in accordance with a work order accounting procedure prescribed by the applicable Federal or State regulatory body.
- (b) Actual and related indirect costs accumulated in accordance with an established accounting procedure developed by the COMPANY and approved by the DEPARTMENT.
- (c) An agreed lump sum \$ 0.00 , as supported by a detail analysis of estimated cost attached hereto. (NOTE: This method is not applicable where the estimated cost of the proposed adjustment exceeds \$100,000.)

10. The installation and/or adjustment of the COMPANY'S facility as planned  will  will not involve additional work over and above the minimum reimbursable requirements of the DEPARTMENT. (If upgrading and/or nonreimbursable work is involved at the option of the COMPANY, then credit against the cost of the project is required and will be governed by the method checked and described hereafter):

- (a) \_\_\_\_\_ % will be applied to the final billing of work actually accomplished to determine required credit for (betterment) and/or (expired service life) and/or (nonreimbursable segments).
- (b) All work involving nonreimbursable segments will be performed by special COMPANY work or job order number apart and separate from the reimbursable portion of the work; such work or job order number to be \_\_\_\_\_. The COMPANY further agrees to clearly identify such additional work areas in the COMPANY'S plans and estimates for the total work covered by this Agreement.
- (c) \$ 0.00 credited for  betterment  expired service life  
 nonreimbursable segments in accord with Article 9.(c) hereinabove.

11. It is specifically agreed by and between the DEPARTMENT and the COMPANY that the DEPARTMENT shall receive fair and adequate credit for any salvage which shall accrue to the COMPANY as a result of the above installation and/or adjustment work.

12. It is further agreed that the cost of all improvements made during this adjustment work shall be borne by the COMPANY, subject only to the DEPARTMENT bearing such portion of this cost as represents the cost of adjustment of previously existing facility, less salvage credit as set forth in the immediately preceding paragraph.



13. Upon completion of the work the COMPANY shall, within one hundred eighty (180) days, furnish the DEPARTMENT with two (2) copies of its final and complete billing of all costs incurred in connection with the work performed hereunder, such statement to follow as closely as possible the order of the items contained in the estimate attached hereto. The totals for labor, overhead, travel expense, transportation, equipment, material and supplies, handling costs and other services shall be shown in such a manner as will permit ready comparison with the approved plans and estimates. Materials shall be itemized where they represent major components of cost in the relocation following the pattern set out in the approved estimate as closely as is possible. Salvage credits from recovered and replaced permanent and recovered temporary materials shall be reported in said bills in relative position with the charge for the replacement or the original charge for temporary use.

The final billing shall show the description and site of the Project; the date on which the first work was performed, or, if preliminary engineering or right-of-way items are involved, the date on which the earliest item of billed expense was incurred; the date on which the last work was performed or the last item of billed expense was incurred; and the location where the records and accounts billed can be audited. Adequate reference shall be made in the billing to the COMPANY'S records, accounts and other relevant documents. All cost records and accounts shall be subject to audit by a representative of the DEPARTMENT. Upon receipt of invoices, prepared in accordance with the provisions of the above indicated Reimbursement Policy, the DEPARTMENT agrees to reimburse the COMPANY in the amount of such actual costs as approved by the DEPARTMENT'S auditor.

14. Payment shall be made only after receipt and approval of goods and services unless advance payments are authorized by the DEPARTMENT'S Comptroller under Section 334.044(29), F.S., or by the Department of Financial Services under Section 215.422(14), Florida Statutes (F.S.).

15. In accordance with Section 287.058, Florida Statutes, the following provisions are in this Agreement: If this Contract involves units of deliverables, then such units must be received and accepted in writing by the Contract Manager prior to payments. Bills for fees or other compensation for services or expenses shall be submitted in detail sufficient for a proper preaudit and postaudit thereof.

16. Bills for travel expenses specifically authorized in this agreement shall be submitted and paid in accordance with DEPARTMENT Rule 14-57.011 "Public Railroad-Highway Grade Crossing Costs" and the Federal Highway Administration Federal-Aid Policy Guide, Subchapter B, Part 140, Subpart I "Reimbursement for Railroad Work."

17. In accordance with Section 215.422, Florida Statutes, the following provisions are in this Agreement:

Contractors providing goods and services to the Department should be aware of the following time frames. Upon receipt, the Department has five (5) working days to inspect and approve the goods and services, unless the Agreement specifies otherwise. The Department has 20 days to deliver a request for payment (voucher) to the Department of Financial Services. The 20 days are measured from the latter of the date the invoice is received or the goods or services are received, inspected and approved.

If a payment is not available within 40 days, a separate interest penalty at a rate as established pursuant to Section 215.422(3)(b), Florida Statutes, will be due and payable, in addition to the invoice amount, to the Contractor. Interest penalties of less than one (1) dollar will not be enforced unless the Contractor requests payment. Invoices which have to be returned to a Contractor because of Contractor preparation errors will result in a delay in the payment. The invoice payment requirements do not start until a properly completed invoice is provided to the Department.

A Vendor Ombudsman has been established within the Department of Financial Services. The duties of this individual include acting as an advocate for contractors/vendors who may be experiencing problems in obtaining timely payment(s) from a state agency. The Vendor Ombudsman may be contacted at (850) 413-5516 or by calling the Division of Consumer Services at 1-877-693-5236.

18. Records of costs incurred under terms of this Agreement shall be maintained and made available upon request to the Department at all times during the period of this Agreement and for five years after final payment is made. Copies of these documents and records shall be furnished to the Department upon request. Records of costs incurred includes the Contractor's general accounting records and the project records, together with supporting documents and records, of the Contractor and all subcontractors performing work on the project, and all other records of the Contractor and subcontractors considered necessary by the Department for a proper audit of costs.

19. In the event this contract is for services in excess of TWENTY FIVE THOUSAND DOLLARS (\$25,000.00) and a term for a period of more than one year, the provisions of Section 339.135(6)(a), Florida Statutes, are hereby incorporated:

The Department, during any fiscal year, shall not expend money, incur any liability, or enter into any contract which, by its terms, involves the expenditure of money in excess of the amounts budgeted as available for expenditure during such fiscal year. Any contract, verbal or written, made in violation of this subsection is null and void, and no money may be paid on such contract. The Department shall require a statement from the Comptroller of the Department that such funds are available prior to entering into any such contract or other binding commitment of funds. Nothing herein contained shall prevent the making of contracts for periods exceeding one year, but any contract so made shall be executory only for the value of the services to be rendered or agreed to be paid for in succeeding fiscal years; and this paragraph shall be incorporated

verbatim in all contracts of the Department which are for an amount in excess of TWENTY FIVE THOUSAND DOLLARS (\$25,000.00) and which have a term for a period of more than one year.

20. In accordance with Section 287.133 (2)(a), Florida Statutes, the following provisions are included in this Agreement:

A person or affiliate who has been placed on the convicted vendor list following a conviction for a public entity crime may not submit a bid, proposal, or reply on a contract to provide any goods or services to a public entity; may not submit a bid, proposal, or reply on a contract with a public entity for the construction or repair of a public building or public work; may not submit bids, proposals, or replies on leases of real property to a public entity; may not be awarded or perform work as a contractor, supplier, subcontractor, or consultant under a contract with any public entity; and may not transact business with any public entity in excess of the threshold amount provided in s.287.017 for CATEGORY TWO for a period of 36 months following the date of being placed on the convicted vendor list.

21. In accordance with Section 287.134(2)(a), Florida Statutes, the following provisions are included in this Agreement:

An entity or affiliate who has been placed on the discriminatory vendor list may not submit a bid, proposal, or reply on a contract to provide any goods or services to a public entity; may not submit a bid, proposal, or reply on a contract with a public entity for the construction or repair of a public building or public work; may not submit bids, proposals, or replies on leases of real property to a public entity; may not be awarded or perform work as a contractor, supplier, subcontractor, or consultant under a contract with any public entity; and may not transact business with any public entity.

22. In accordance with Section 287.0582, Florida Statutes, the following provision is included in this Agreement:

The Department's obligation to pay under this contract is contingent upon an annual appropriation by the Florida Legislature.

~~23. The COMPANY covenants and agrees that it will indemnify and hold harmless the DEPARTMENT and all of the DEPARTMENT'S officers, agents, and employees from any claim, loss, damage, cost charge, or expense arising out of any act, action, neglect, omission or delay by the COMPANY, during the performance of the contract, whether direct or indirect, and whether to any person or property to which the DEPARTMENT or said parties may be subject, except that neither the COMPANY nor any of its sub-contractors will be liable under this section for damages arising out of injury or damage to persons or property directly caused or resulting from the sole negligence of the DEPARTMENT or any of its officers, agents, or employees.~~

24. COMPANY shall:

1. utilize the U.S. Department of Homeland Security's E-Verify system to verify the employment eligibility of all new employees hired by the COMPANY during the term of the contract; and
2. expressly require any subcontractors performing work or providing services pursuant to the state contract to likewise utilize the U.S. Department of Homeland Security's E-Verify system to verify the employment eligibility of all new employees hired by the subcontractor during the contract term.

25. It is understood and agreed by the parties to this Agreement that if any part, term, or provision of this Agreement is held illegal by the courts or in conflict with any law of the State of Florida, the validity of the remaining portions or provisions shall not be affected, and the rights and obligations of the parties shall be construed and enforced as if the Agreement did not contain the particular part, term, or provision held to be invalid.

26. Any questions or matters arising under this Agreement as to validity, construction, enforcement, performance, or otherwise, shall be determined in accordance with the laws of the State of Florida. Venue for any action arising out of or in any way related to this Agreement shall lie exclusively in a state court of appropriate jurisdiction in Leon County, Florida.

27. The parties agree to bear their own attorney's fees and costs with respect to this Agreement.

28. The parties agree that this Agreement is binding on the parties, their heirs-at-law, and their assigns and successors in interest as evidenced by their signatures and lawful executions below.

29. A modification or waiver of any of the provisions of this Agreement shall be effective only if made in writing and executed with the same formality as this Agreement.

30. Paragraph 23 was stricken prior to execution by all parties, at the request of FLORIDA EAST COAST RAILWAY L.L.C.

IN WITNESS WHEREOF, the parties hereto have caused these presents to be executed by their duly authorized officers, the day and year first above written.

STATE OF FLORIDA  
DEPARTMENT OF TRANSPORTATION

BY: \_\_\_\_\_  
(TITLE: Director of Transportation Development )

COMPANY: Florida East Coast Railway Company

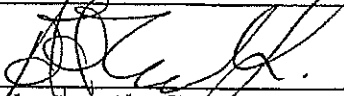
BY:   
A.G. Fowler Jr. - Chief Engineer, Signals & Communication

Miami-Dade COUNTY, FLORIDA

BY: \_\_\_\_\_  
(TITLE: \_\_\_\_\_ )

Legal Review

Approved as to Funds Available

Approved as to FAPG Requirements

BY: \_\_\_\_\_  
Attorney - DOT Date

BY: \_\_\_\_\_  
Comptroller - DOT Date

BY: \_\_\_\_\_  
FHWA Date



2013 Diagnostics

DATE: 09/12/12  
 TYPE: 4  
 CLASS: 3  
 NO. OF DAYS: 14  
 AAR / DOT #: 273141M  
 MILE POST: PL 5 + 4310'  
 Project Type: FDOT

OFFICE OF THE CHIEF ENGINEER  
 SIGNALS AND COMMUNICATIONS

ESTIMATED COST FOR HIGHWAY CROSSING WARNING DEVICES AT CARIBBEAN WAY EAST.  
 This estimate should be considered void after one (1) year.

MATERIAL	UNIT COST	UNITS	TOTAL COST
GATE ASSEMBLIES	\$9,784.00	2 EA.	\$19,568.00
GATES	\$500.00	2 EA.	\$1,000.00
GATE FOUNDATIONS	\$675.00	2 EA.	\$1,350.00
CANTILEVERS 40'	\$19,905.00	2 EA.	\$39,810.00
CANTILEVER FOUNDATIONS	\$4,500.00	2 EA.	\$9,000.00
6'X6' WIRED CASE, WITH HXP-3R2	\$55,179.00	1 EA.	\$55,179.00
GENERATOR CASE W/ TRANSFER SWITCH	\$5,615.00	1 EA.	\$5,615.00
BATTERY BOX	\$675.00	1 EA.	\$675.00
BATTERIES, SAFT SPL250	\$250.00	30 EA.	\$7,500.00
MISC. GROUND MATERIAL	\$1,991.40	1 PKG.	\$1,991.40
CONDUIT & DIRECTIONAL BORE	\$45.00	110 FT.	\$4,950.00
CABLE	\$14,500.00	1 PKG.	\$14,500.00
MISCELLANEOUS RELAY EQUIPMENT	\$1,120.00	1 PKG.	\$1,120.00
POWER SERVICE	\$1,800.00	1 EA.	\$1,800.00
MONITORING EQUIPMENT	\$10,725.00	1 PKG.	\$10,725.00
SANITATION & DISPOSAL	\$1,500.00	1 PKG.	\$1,500.00
FREIGHT & HANDLING			\$43,696.00
TAX @ 6.5%			<u>\$11,361.00</u>
<b>TOTAL MATERIALS</b>			<b>\$231,340.40</b>
EXCAVATING EQUIPMENT PER DAY	\$417.10	14 DAYS	\$5,839.40
EQUIPMENT RENTAL PER DAY	\$200.00	14 DAYS	\$2,800.00
FOREMAN'S TRUCK PER DAY	\$224.70	14 DAYS	\$3,145.80
GANG TRUCK PER DAY	\$647.30	14 DAYS	\$9,062.20
SUPERVISORS TRUCK PER DAY	\$142.60	14 DAYS	<u>\$1,996.40</u>
<b>EQUIPMENT TOTAL</b>			<b>\$22,844.00</b>
DESIGN ENGINEERING	\$7,500.00	1	\$7,500.00
CONTRACT ENGINEERING	\$12,650.00	1	\$12,650.00
CONSTRUCTION ENGINEERING INSPECTION	\$1,350.00	3 DAYS	<u>\$4,050.00</u>
<b>ENGINEERING TOTAL</b>			<b>\$24,200.00</b>
CONSTRUCTION SUPERVISION	\$375.00	14 DAYS	\$5,250.00
LABOR ADDITIVE			<u>\$3,031.00</u>
<b>TOTAL SUPERVISION LABOR</b>			<b>\$8,281.00</b>
LABOR PER DAY	\$1,392.40		\$19,494.00
NUMBER OF DAYS	14		
LABOR ADDITIVE			<u>\$11,481.00</u>
<b>TOTAL GANG LABOR</b>			<b>\$30,955.00</b>
GANG EXPENSES PER DAY	\$803.00		
NUMBER OF DAYS	14		
<b>TOTAL GANG EXPENSES</b>			<b>\$11,242.00</b>
<b>ESTIMATED FLAGGING TOTAL</b>	<b>\$1,000.00</b>	<b>14 DAYS</b>	<b>\$14,000.00</b>
<b>SUB-TOTAL</b>			<b>\$342,862.40</b>
CONTINGENCIES 5%			\$17,143.00
<b>TOTAL</b>			<b>\$360,010.00</b>

ESTIMATE NOTES:

NEW CROSSING WARNING DEVICES COMPLETE, CFLBG

**SCHEDULE OF ANNUAL COST OF AUTOMATIC  
HIGHWAY GRADE CROSSING TRAFFIC CONTROL DEVICES**

---

**STANDARD 2 QUADRANT SIGNAL INSTALLATIONS**

Annual Maintenance Cost Exclusive of Installation

<u>CLASS</u>	<u>DESCRIPTION</u>	<u>COST*</u>
I	Flashing Signals – One Track	\$2,256.00
II	Flashing Signals – Multiple Tracks	\$2,985.00
III	Flashing Signals and Gates – One Track	\$3,402.00
IV	Flashing Signals and Gates – Multiple Tracks	\$4,272.00

**3 OR 4 QUADRANT SIGNAL INSTALLATIONS**

Annual Maintenance Cost Exclusive of Installation

<u>CLASS</u>	<u>DESCRIPTION</u>	<u>COST*</u>
III	Flashing Signals and Gates – One Track	\$6,726.00
IV	Flashing Signals and Gates – Multiple Tracks	\$8,442.00

AUTHORITY: FLORIDA ADMINISTRATIVE RULE: 14-57.011  
Public Railroad- Highway Grade Crossing Costs

F. A. RULE EFFECTIVE DATE: July 22, 1982

GENERAL AUTHORITY: 334.044, F. S.

SPECIFIC LAW IMPLEMENTED: 335.141, F. S.

\*This schedule was effective July 1, 2011, and will be reviewed every 5 years and revised as appropriate based on the Consumer Price Index for all Urban Consumers published by the U.S. Department of Labor.

LAST REVISION	DESCRIPTION:	 <b>FDOT DESIGN STANDARDS</b> 2013	<b>RAILROAD GRADE CROSSING TRAFFIC CONTROL DEVICES</b>	INDEX NO.	17882
01/01/11				SHEET NO.	1

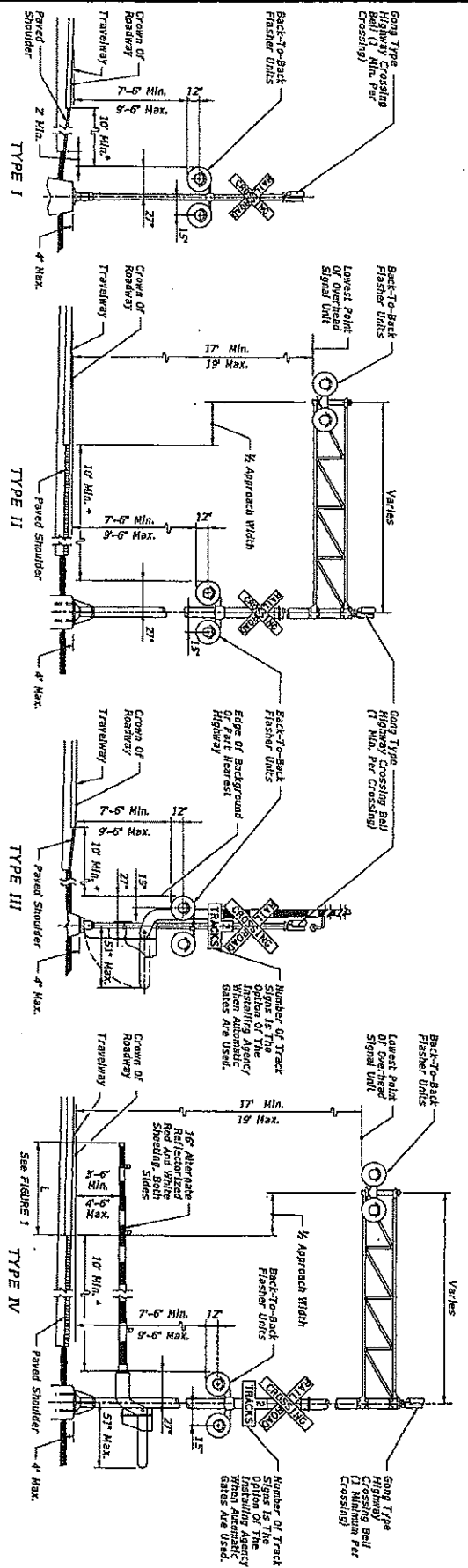

**General Notes**

- No standard is proposed for signals; however, some form of impact attenuation device may be specified for certain locations.
- Advance flasher to be installed when and if called for in plans or specifications.
- Top of foundation shall be no higher than 4' above finished shoulder grade.
- Type of traffic control device
  - Flashing signals
  - Flashing signals with cantilever
  - Flashing signals with cantilever and gate
  - Gate
- Class of traffic control devices
  - Flashing signals-one track
  - Flashing signals and gates-one track
  - Flashing signals and gates-multiple tracks

Notes:  
 \* When 15' is deemed impracticable the control device can be but not less than 9' from the edge of the near traffic lane.  
 † Two separate foundations may be required (one for signals, one for gate), depending on type of equipment used.

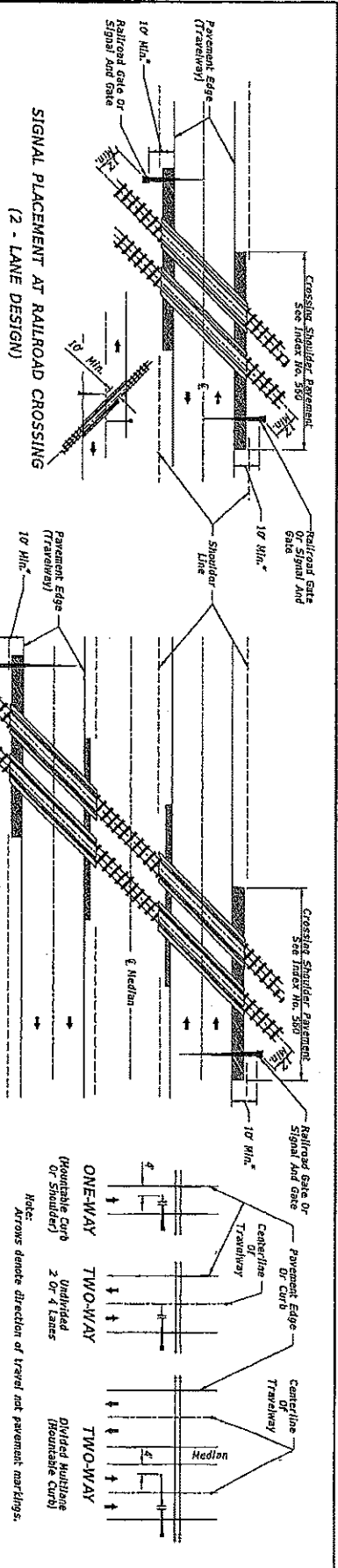



RAILROAD CROSSING AT  
TWO (2)-LANE ROADWAY

RAILROAD CROSSING AT  
MULTILANE ROADWAY

RELATIVE LOCATION OF CROSSING TRAFFIC  
CONTROL DEVICES

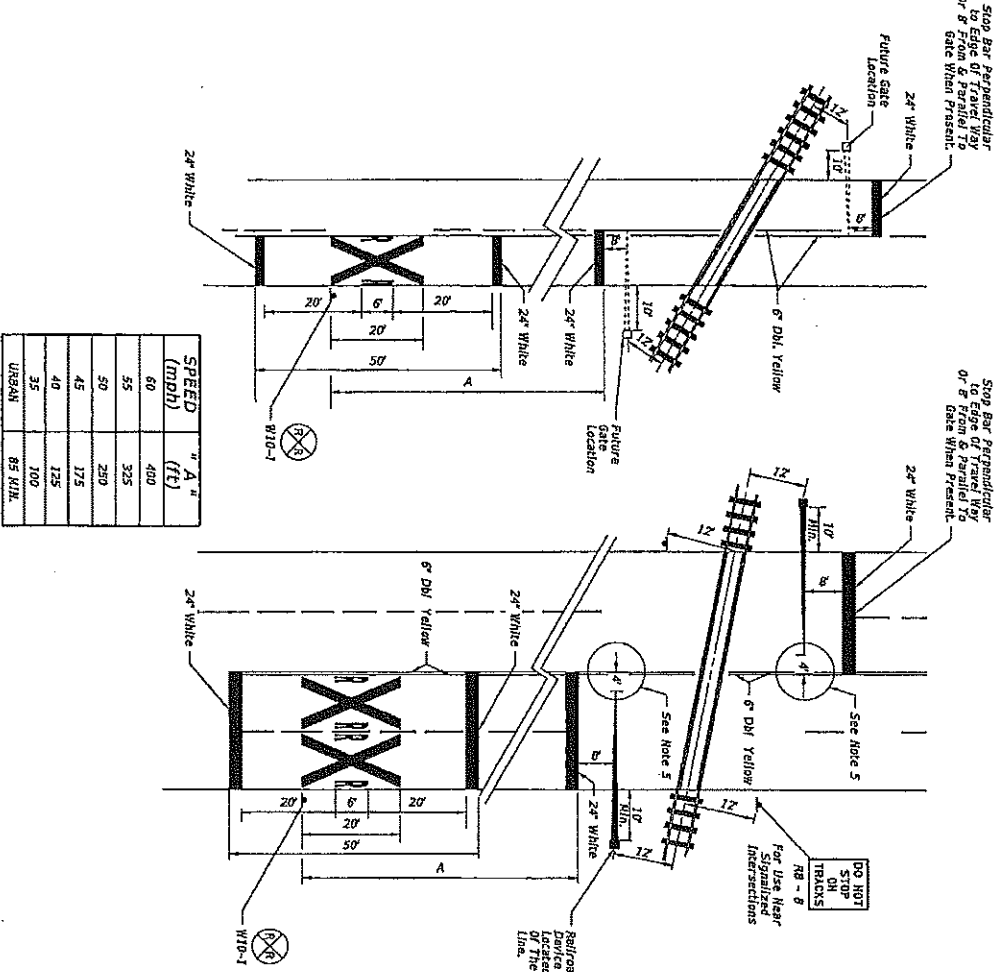

SPEED (mph)	" A "
60	400
55	325
50	280
45	175
40	125
35	100
URBAN	85 MIN.

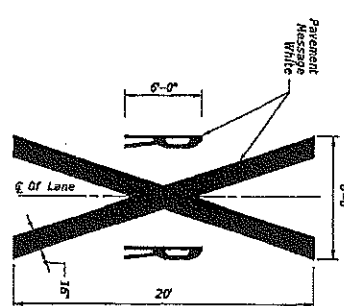
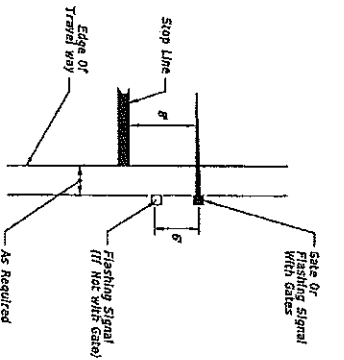

- NOTES:**
- When computing pavement message quantities do not include traverse lines.
  - Placement of sign W10-1 in a residential or business district, or in a school zone, shall be such that the sign is visible from a minimum distance of 100' from the crossing where street crossings occur between the RR pavement message and the message should be used.
  - A portion of the pavement markings symbol should be directly opposite the W10-1 sign.
  - Recommended location for FTR-61-06 or FTR-62-06 signs, 100' urban and 300' rural. See Index 17355 for sign details.
  - Gate length requirements:  
For T-bar and roller sections:  
The gate should extend to within 1' of the center line. On multiple approaches the maximum gate length may not reach to within 1' of the center line. For those cases, the distance from the gate to the center line shall be a maximum of 4'.  
For one-way or divided sections:  
The gate shall be of sufficient length such that the distance from the gate to the middle edge of pavement is a maximum of 4'.

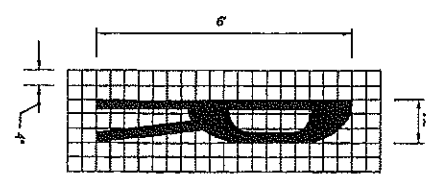

LAST REVISION	DESCRIPTION:	INDEX NO.	SHEET NO.
07/03/10		17882	3

FDOT DESIGN STANDARDS 2013

RAILROAD GRADE CROSSING TRAFFIC CONTROL DEVICES

STATE OF FLORIDA DEPARTMENT OF TRANSPORTATION  
**RAILROAD REIMBURSEMENT AGREEMENT**  
**GRADE CROSSING TRAFFIC CONTROL DEVICES - COUNTY**

725-090-27  
 RAIL  
 OGC - 04/12

FINANCIAL PROJECT NO.	ROAD NAME OR NUMBER	COUNTY NAME	PARCEL & R/W NUMBER	FAP NUMBER
43329815701	Caribbean Way West	MIAMI-DADE	1(SIG-B)	N/A

THIS AGREEMENT, made and entered into this \_\_\_\_\_ day of \_\_\_\_\_, \_\_\_\_\_, by and between the STATE OF FLORIDA DEPARTMENT OF TRANSPORTATION, hereinafter called the DEPARTMENT, and Florida East Coast Railway Company, a corporation organized and existing under the laws of Florida, with its principal place of business in the City of Jacksonville, County of Duval State of Florida, hereinafter called the COMPANY; and Miami-Dade County, a political subdivision of the State of Florida, acting by and through its Board of County Commissioners, hereinafter called the COUNTY.

WITNESSETH:

WHEREAS, the DEPARTMENT is constructing, reconstructing or otherwise changing a portion of the Public Road System, designated by the Financial Project ID 43329815701, on Caribbean Way West, which crosses at grade the right of way and tracks of the COMPANY'S Milepost PL 5+3519', FDOT/AAR Crossing Number 273140F, at or near Caribbean Way West, as shown on DEPARTMENT'S Plan Sheet No: N/A, attached hereto as a part hereof; and

NOW, THEREFORE, in consideration of the mutual undertakings as herein set forth, the parties hereto agree as follows:

- The COMPANY shall furnish the necessary materials and install Automatic Grade Crossing Signals Type 3 Class 3 and/or other traffic control devices at said location on an actual cost basis and in accordance with (1) the attached detailed statement of the work, plans, and specifications; and (2) the DEPARTMENT'S Plans and Standard Index Number 17882 attached hereto and made a part hereof.
- After installation of said signals is completed, <sup>100%</sup> ~~fifty (50%)~~ percent of the expense thereof in maintaining the same shall be borne by the COUNTY and <sup>JS</sup> ~~fifty (50%)~~ percent shall be borne by the COMPANY, as enumerated by the Schedule of Annual Cost of Automatic Highway Grade Crossing Devices attached hereto and by this reference made a part hereof and subject to future revision.
- After said signals have been installed and found to be in satisfactory working order by the parties hereto, the same shall be immediately put into service, operated and maintained by the COMPANY so long as said COMPANY or its successors or assigns shall operate the said signals at said grade crossing; or until it is agreed between the parties hereto that the signals are no longer necessary or until the said crossing is abandoned; or legal requirements occur which shall cease operation of signals thereat.

The COMPANY agrees that any future relocation or adjustment of said signals shall be performed by the COMPANY, but at the expense of the party initiating such relocation. Upon relocation the maintenance responsibilities shall be in accordance with the provisions of this agreement. It is further agreed that the cost of maintaining any additional or replacement signal equipment at the same location will be shared as provided under Paragraph 2. above.

4. Unless otherwise agreed upon herein, the COUNTY agrees to ensure that at the crossing the advance warning signs and railroad crossing pavement markings will conform to the U.S. Department of Transportation Manual on Uniform Traffic Control Devices within 30 days of notification that the railroad signal improvements have been completed and that such signs and pavement markings will be continually maintained at an acceptable level.

5. The COMPANY hereby agrees to install and/or adjust the necessary parts of its facilities along said road in accordance with the provisions set forth in the:

- (a) DEPARTMENT Procedure No. 725-080-002 Appendix D.4, and Rule 14.57.011 "Public Railroad-Highway Grade Crossing Costs", Florida Administrative Code.
- (b) Federal Highway Administration Federal-Aid Policy Guide, 23 C.F.R. Subchapter G, Part 646, Subpart B, and 23 C.F.R., Subchapter B, Part 140, Subpart I,

and any supplements thereto or revisions thereof, which, by reference hereto, are made a part hereof. The COMPANY further agrees to do all of such work, with its own forces or by a contractor paid under a contract let by the COMPANY, all under the supervision and approval of the DEPARTMENT and the Federal Highway Administration, when applicable.

6. The DEPARTMENT hereby agrees to reimburse the COMPANY for all costs incurred by it in the installation and/or adjustment of said facilities, in accordance with the provisions of Procedure No. 725-080-002 Appendix D-4 "Billing Requirements," and any supplements thereto or revisions thereof. It is understood and agreed by and between the parties hereto that preliminary engineering costs not incorporated within this agreement shall not be subject to payment by the DEPARTMENT.

7. Attached hereto, and by this reference made a part hereof, are plans and specifications of the work to be performed by the COMPANY pursuant to the terms hereof, and an itemized estimate of the cost thereof in the amount of \$ 333,480.00 . All work performed by the COMPANY pursuant hereto, shall be performed according to these plans and specifications as approved by the DEPARTMENT and the Federal Highway Administration if federal aid participating; and all subsequent plan changes shall likewise be approved by the DEPARTMENT and the Federal Highway Administration, when applicable.

8. All labor, services, materials, and equipment furnished by the COMPANY in carrying out the work to be performed hereunder shall be billed by the COMPANY direct to the DEPARTMENT. Separate records as to the costs of

contract bid items and force account items performed for the COMPANY shall also be furnished by the COMPANY to the DEPARTMENT.

9. The COMPANY has determined that the method to be used in developing the relocation or installation cost shall be as specified for the method checked and described hereafter:

- (a) Actual and related indirect costs accumulated in accordance with a work order accounting procedure prescribed by the applicable Federal or State regulatory body.
- (b) Actual and related indirect costs accumulated in accordance with an established accounting procedure developed by the COMPANY and approved by the DEPARTMENT.
- (c) An agreed lump sum \$ 0.00, as supported by a detail analysis of estimated cost attached hereto. (NOTE: This method is not applicable where the estimated cost of the proposed adjustment exceeds \$100,000.)

10. The installation and/or adjustment of the COMPANY'S facility as planned  will  will not involve additional work over and above the minimum reimbursable requirements of the DEPARTMENT. (If upgrading and/or nonreimbursable work is involved at the option of the COMPANY, then credit against the cost of the project is required and will be governed by the method checked and described hereafter):

- (a) \_\_\_\_\_ % will be applied to the final billing of work actually accomplished to determine required credit for (betterment) and/or (expired service life) and/or (nonreimbursable segments).
- (b) All work involving nonreimbursable segments will be performed by special COMPANY work or job order number apart and separate from the reimbursable portion of the work; such work or job order number to be \_\_\_\_\_. The COMPANY further agrees to clearly identify such additional work areas in the COMPANY'S plans and estimates for the total work covered by this Agreement.
- (c) \$ 0.00 credited for  betterment  expired service life  
 nonreimbursable segments in accord with Article 9.(c) hereinabove.

11. It is specifically agreed by and between the DEPARTMENT and the COMPANY that the DEPARTMENT shall receive fair and adequate credit for any salvage which shall accrue to the COMPANY as a result of the above installation and/or adjustment work.

12. It is further agreed that the cost of all improvements made during this adjustment work shall be borne by the COMPANY, subject only to the DEPARTMENT bearing such portion of this cost as represents the cost of adjustment of previously existing facility, less salvage credit as set forth in the immediately preceding paragraph.

17. In accordance with Section 215.422, Florida Statutes, the following provisions are in this Agreement:

Contractors providing goods and services to the Department should be aware of the following time frames. Upon receipt, the Department has five (5) working days to inspect and approve the goods and services, unless the Agreement specifies otherwise. The Department has 20 days to deliver a request for payment (voucher) to the Department of Financial Services. The 20 days are measured from the latter of the date the invoice is received or the goods or services are received, inspected and approved.

If a payment is not available within 40 days, a separate interest penalty at a rate as established pursuant to Section 215.422(3)(b), Florida Statutes, will be due and payable, in addition to the invoice amount, to the Contractor. Interest penalties of less than one (1) dollar will not be enforced unless the Contractor requests payment. Invoices which have to be returned to a Contractor because of Contractor preparation errors will result in a delay in the payment. The invoice payment requirements do not start until a properly completed invoice is provided to the Department.

A Vendor Ombudsman has been established within the Department of Financial Services. The duties of this individual include acting as an advocate for contractors/vendors who may be experiencing problems in obtaining timely payment(s) from a state agency. The Vendor Ombudsman may be contacted at (850) 413-5516 or by calling the Division of Consumer Services at 1-877-693-5236.

18. Records of costs incurred under terms of this Agreement shall be maintained and made available upon request to the Department at all times during the period of this Agreement and for five years after final payment is made. Copies of these documents and records shall be furnished to the Department upon request. Records of costs incurred includes the Contractor's general accounting records and the project records, together with supporting documents and records, of the Contractor and all subcontractors performing work on the project, and all other records of the Contractor and subcontractors considered necessary by the Department for a proper audit of costs.

19. In the event this contract is for services in excess of TWENTY FIVE THOUSAND DOLLARS (\$25,000.00) and a term for a period of more than one year, the provisions of Section 339.135(6)(a), Florida Statutes, are hereby incorporated:

The Department, during any fiscal year, shall not expend money, incur any liability, or enter into any contract which, by its terms, involves the expenditure of money in excess of the amounts budgeted as available for expenditure during such fiscal year. Any contract, verbal or written, made in violation of this subsection is null and void, and no money may be paid on such contract. The Department shall require a statement from the Comptroller of the Department that such funds are available prior to entering into any such contract or other binding commitment of funds. Nothing herein contained shall prevent the making of contracts for periods exceeding one year, but any contract so made shall be executory only for the value of the services to be rendered or agreed to be paid for in succeeding fiscal years; and this paragraph shall be incorporated

verbatim in all contracts of the Department which are for an amount in excess of TWENTY FIVE THOUSAND DOLLARS (\$25,000.00) and which have a term for a period of more than one year.

20. In accordance with Section 287.133 (2)(a), Florida Statutes, the following provisions are included in this Agreement:

A person or affiliate who has been placed on the convicted vendor list following a conviction for a public entity crime may not submit a bid, proposal, or reply on a contract to provide any goods or services to a public entity; may not submit a bid, proposal, or reply on a contract with a public entity for the construction or repair of a public building or public work; may not submit bids, proposals, or replies on leases of real property to a public entity; may not be awarded or perform work as a contractor, supplier, subcontractor, or consultant under a contract with any public entity; and may not transact business with any public entity in excess of the threshold amount provided in s.287.017 for CATEGORY TWO for a period of 36 months following the date of being placed on the convicted vendor list.

21. In accordance with Section 287.134(2)(a), Florida Statutes, the following provisions are included in this Agreement:

An entity or affiliate who has been placed on the discriminatory vendor list may not submit a bid, proposal, or reply on a contract to provide any goods or services to a public entity; may not submit a bid, proposal, or reply on a contract with a public entity for the construction or repair of a public building or public work; may not submit bids, proposals, or replies on leases of real property to a public entity; may not be awarded or perform work as a contractor, supplier, subcontractor, or consultant under a contract with any public entity; and may not transact business with any public entity.

22. In accordance with Section 287.0582, Florida Statutes, the following provision is included in this Agreement:

The Department's obligation to pay under this contract is contingent upon an annual appropriation by the Florida Legislature.

~~23. The COMPANY covenants and agrees that it will indemnify and hold harmless the DEPARTMENT and all of the DEPARTMENT'S officers, agents, and employees from any claim, loss, damage, cost charge, or expense arising out of any act, action, neglect, omission or delay by the COMPANY during the performance of the contract, whether direct or indirect, and whether to any person or property to which the DEPARTMENT or said parties may be subject, except that neither the COMPANY nor any of its sub-contractors will be liable under this section for damages arising out of injury or damage to persons or property directly caused or resulting from the sole negligence of the DEPARTMENT or any of its officers, agents, or employees.~~

24. COMPANY shall:

1. utilize the U.S. Department of Homeland Security's E-Verify system to verify the employment eligibility of all new employees hired by the COMPANY during the term of the contract; and
2. expressly require any subcontractors performing work or providing services pursuant to the state contract to likewise utilize the U.S. Department of Homeland Security's E-Verify system to verify the employment eligibility of all new employees hired by the subcontractor during the contract term.

25. It is understood and agreed by the parties to this Agreement that if any part, term, or provision of this Agreement is held illegal by the courts or in conflict with any law of the State of Florida, the validity of the remaining portions or provisions shall not be affected, and the rights and obligations of the parties shall be construed and enforced as if the Agreement did not contain the particular part, term, or provision held to be invalid.

26. Any questions or matters arising under this Agreement as to validity, construction, enforcement, performance, or otherwise, shall be determined in accordance with the laws of the State of Florida. Venue for any action arising out of or in any way related to this Agreement shall lie exclusively in a state court of appropriate jurisdiction in Leon County, Florida.

27. The parties agree to bear their own attorney's fees and costs with respect to this Agreement.

28. The parties agree that this Agreement is binding on the parties, their heirs-at-law, and their assigns and successors in interest as evidenced by their signatures and lawful executions below.

29. A modification or waiver of any of the provisions of this Agreement shall be effective only if made in writing and executed with the same formality as this Agreement.

30. Paragraph 23 was stricken prior to execution by all parties, at the request of FLORIDA EAST COAST RAILWAY L.L.C.

IN WITNESS WHEREOF, the parties hereto have caused these presents to be executed by their duly authorized officers, the day and year first above written.

STATE OF FLORIDA  
DEPARTMENT OF TRANSPORTATION

BY: \_\_\_\_\_  
(TITLE: Director of Transportation Development )

COMPANY: Florida East Coast Railway Company

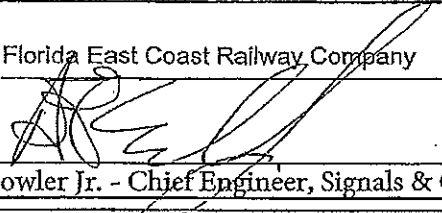
BY:   
A.G. Fowler Jr. - Chief Engineer, Signals & Communication

Miami-Dade COUNTY, FLORIDA

BY: \_\_\_\_\_  
(TITLE: \_\_\_\_\_ )

Legal Review  
BY: \_\_\_\_\_  
Attorney - DOT                      Date

Approved as to Funds Available  
BY: \_\_\_\_\_  
Comptroller - DOT                      Date

Approved as to FAPG Requirements  
BY: \_\_\_\_\_  
FHWA                                      Date





OFFICE OF THE CHIEF ENGINEER  
OF SIGNALS AND COMMUNICATIONS

2013 Diagnostics

DATE: 09/12/12  
TYPE: 3  
CLASS: 3  
NO. OF DAYS: 12  
AAR / DOT #: 273140F  
MILE POST: PL 5 + 3519'

Project Type: FDOT

ESTIMATED COST FOR HIGHWAY CROSSING WARNING DEVICES AT CARIBBEAN WAY (FARTHEST WEST).

This estimate should be considered void after one (1) year.

MATERIAL	UNIT COST	UNITS	TOTAL COST
GATE ASSEMBLIES	\$9,784.00	4 EA.	\$39,136.00
GATES	\$500.00	4 EA.	\$2,000.00
GATE FOUNDATIONS	\$675.00	5 EA.	\$3,375.00
MAST & FLASHING LIGHT ASSEMBLY	\$3,317.00	1 EA.	\$3,317.00
6'X6' WIRED CASE, WITH HXP-3R2	\$61,179.00	1 EA.	\$61,179.00
GENERATOR CASE W/ TRANSFER SWITCH	\$5,615.00	1 EA.	\$5,615.00
BATTERY BOX	\$675.00	2 EA.	\$1,350.00
BATTERIES, SAFT SPL250	\$250.00	40 EA.	\$10,000.00
MISC. GROUND MATERIAL	\$1,991.40	1 PKG.	\$1,991.40
CONDUIT & DIRECTIONAL BORE	\$45.00	110 FT.	\$4,950.00
CABLE	\$18,500.00	1 PKG.	\$18,500.00
MISCELLANEOUS RELAY EQUIPMENT	\$1,120.00	1 PKG.	\$1,120.00
POWER SERVICE	\$1,800.00	1 EA.	\$1,800.00
MONITORING EQUIPMENT	\$10,725.00	1 PKG.	\$10,725.00
SANITATION & DISPOSAL	\$1,500.00	1 PKG.	\$1,500.00
FREIGHT & HANDLING			\$41,265.00
TAX @ 6.5%			<u>\$10,729.00</u>
<b>TOTAL MATERIALS</b>			<b>\$218,552.40</b>
EXCAVATING EQUIPMENT PER DAY	\$417.10	12 DAYS	\$5,005.20
EQUIPMENT RENTAL PER DAY	\$200.00	12 DAYS	\$2,400.00
FOREMAN'S TRUCK PER DAY	\$224.70	12 DAYS	\$2,696.40
GANG TRUCK PER DAY	\$647.30	12 DAYS	\$7,767.60
SUPERVISORS TRUCK PER DAY	\$142.60	12 DAYS	<u>\$1,711.20</u>
<b>EQUIPMENT TOTAL</b>			<b>\$19,580.00</b>
DESIGN ENGINEERING	\$7,500.00	1	\$7,500.00
CONTRACT ENGINEERING	\$12,650.00	1	\$12,650.00
CONSTRUCTION ENGINEERING INSPECTION	\$1,350.00	3 DAYS	<u>\$4,050.00</u>
<b>ENGINEERING TOTAL</b>			<b>\$24,200.00</b>
CONSTRUCTION SUPERVISION	\$375.00	12 DAYS	\$4,500.00
LABOR ADDITIVE			<u>\$2,598.00</u>
<b>TOTAL SUPERVISION LABOR</b>			<b>\$7,098.00</b>
LABOR PER DAY	\$1,392.40		\$16,709.00
NUMBER OF DAYS	12		
LABOR ADDITIVE			<u>\$9,823.00</u>
<b>TOTAL GANG LABOR</b>			<b>\$26,532.00</b>
GANG EXPENSES PER DAY	\$803.00		
NUMBER OF DAYS	12		
<b>TOTAL GANG EXPENSES</b>			<b>\$9,636.00</b>
<b>ESTIMATED FLAGGING TOTAL</b>	<b>\$1,000.00</b>	<b>12 DAYS</b>	<b>\$12,000.00</b>
<b>SUB-TOTAL</b>			<b>\$317,598.40</b>
CONTINGENCIES 5%			<u>\$15,880.00</u>
<b>TOTAL</b>			<b>\$333,480.00</b>

ESTIMATE NOTES:

NEW CROSSING WARNING DEVICES COMPLETE, FBG

**SCHEDULE OF ANNUAL COST OF AUTOMATIC  
HIGHWAY GRADE CROSSING TRAFFIC CONTROL DEVICES**

**STANDARD 2 QUADRANT SIGNAL INSTALLATIONS**

Annual Maintenance Cost Exclusive of Installation

<u>CLASS</u>	<u>DESCRIPTION</u>	<u>COST*</u>
I	Flashing Signals – One Track	\$2,256.00
II	Flashing Signals – Multiple Tracks	\$2,985.00
III	Flashing Signals and Gates – One Track	\$3,402.00
IV	Flashing Signals and Gates – Multiple Tracks	\$4,272.00

**3 OR 4 QUADRANT SIGNAL INSTALLATIONS**

Annual Maintenance Cost Exclusive of Installation

<u>CLASS</u>	<u>DESCRIPTION</u>	<u>COST*</u>
III	Flashing Signals and Gates – One Track	\$6,726.00
IV	Flashing Signals and Gates – Multiple Tracks	\$8,442.00

AUTHORITY: FLORIDA ADMINISTRATIVE RULE: 14-57.011  
Public Railroad- Highway Grade Crossing Costs

F. A. RULE EFFECTIVE DATE: July 22, 1982  
GENERAL AUTHORITY: 334.044, F. S.  
SPECIFIC LAW IMPLEMENTED: 335.141, F. S.

\*This schedule was effective July 1, 2011, and will be reviewed every 5 years and revised as appropriate based on the Consumer Price Index for all Urban Consumers published by the U.S. Department of Labor.

## FLORIDA DEPARTMENT OF TRANSPORTATION

Listed Below are signal installations by type and class:

FLASHING SIGNALS - ONE TRACK

Type = 1, Class = 1

FLASHING SIGNALS - MULTIPLE TRACKS

Type = 1, Class = 2

FLASHING SIGNALS AND CANTILEVER - ONE TRACK

Type = 2, Class = 1

FLASHING SIGNALS AND CANTILEVERS - MULTIPLE TRACKS

Type = 2, Class = 2

FLASHING SIGNALS AND GATE - ONE TRACK

Type = 3, Class = 3

FLASHING SIGNALS AND GATE - MULTIPLE TRACKS

Type = 3, Class = 4

FLASHING SIGNALS AND GATE WITH CANTILEVER - ONE TRACK

Type = 4, Class = 3

FLASHING SIGNALS AND GATE WITH CANTILEVER - MULTIPLE

TRACKS Type = 4, Class = 4

### TYPE OF TRAFFIC CONTROL DEVICES

- I Flashing signals
- II Flashing signals with cantilevers
- III Flashing signals with gate
- IV Flashing signals with cantilevers & gate

### CLASS OF TRAFFIC CONTROL DEVICES

- I Flashing signals - one track
- II Flashing signals - multiple track
- III Flashing signals & gates - one track
- IV Flashing signals & gates - multiple track

## FLORIDA EAST COAST RAILWAY, L.L.C. INSURANCE REQUIREMENTS

A. Liability Insurance. During the Term of this Contract, Contractor shall purchase and maintain: (i) Commercial General Liability Insurance ("CGL"), with contractual liability covering obligations assumed in this Contract (including any agreements entered into between the parties pursuant hereto) by Contractor, providing for available limits of not less than \$6,000,000 single limit, bodily injury and/or property damage combined, for damages arising out of bodily injuries to or death of all persons in each occurrence and for damage to or destruction of property, including the loss of use thereof, in each occurrence, including Federal Employers Liability Act claims ("FELA") against the FECR, or other liability arising out of or incidental to railroad operations; (ii) at FECR's option, Contractor will obtain a policy of Railroad Protective Liability with liability limits of \$2,000,000 per occurrence, \$6,000,000 aggregate with FECR as the only named insured; (iii) Statutory Workers' Compensation, Employer's Liability Insurance with available limits of not less than \$1,000,000 and Occupational Disease Insurance; (iv) if any motor vehicles are used in connection with the Services to be performed hereunder (or in connection with any agreements entered into between the parties pursuant hereto), Business Automobile Liability Insurance with limits of not less than \$1,000,000 single limit, bodily injury and/or property damage combined, for damages to or destruction of property including the loss of use thereof, in any one occurrence; and (v) if professional services are being rendered by Contractor, Professional Liability coverage in an amount not less than \$1,000,000. If, in FECR's opinion, a higher limit of liability is necessary for any insurance policy required hereunder, FECR shall so notify Contractor and Contractor shall, within thirty (30) days of receipt of such notice, provide a copy of the endorsement to the appropriate policy increasing the liability coverage to the required limit. Such insurance will include a minimum of two years' tail coverage necessary to cover claims occurring during the Term but which may not be brought until after termination of this Contract.

B. Policy Requirements. All insurance required hereunder shall be affected by valid and enforceable policies issued by insurer(s) of financial responsibility and authorized to do business in all necessary states, all subject to the reasonable prior approval of FECR. Contractor's liability insurance policies shall name FECR, its parent, affiliates and subsidiaries as additional insureds and will not have any exclusion for liability relating to railroad operations or contractual liability for construction or demolition within fifty (50) feet of FECR's tracks by endorsement. Contractor's Workers' Compensation and property insurance policies shall include waivers of subrogation rights endorsements in favor of FECR. All policies shall contain a provision for thirty (30) days' written notice to FECR prior to any expiration or termination of, or any change in, the coverage provided. Contractor shall provide FECR with at least thirty (30) days' written notice prior to such expiration, termination or change in any insurance coverage. Insurance Company must be issued by a casualty company/insurance company authorized to do business in the State of Florida that has a "Best's" rating of A or A+ and a financial category size of Class XII or higher. Prior to any entry upon FECR property pursuant to this Contract and upon FECR's request thereafter, Contractor shall provide or shall cause its insurer or insurance agent to provide FECR (at the address in Paragraph 21) with a certificate of insurance certifying the liability insurance policies in effect for the Term of this Contract. The liability assumed by Contractor under this Contract, including, but not limited to, Contractor's indemnification obligations, shall not be limited to the insurance coverage stipulated herein.

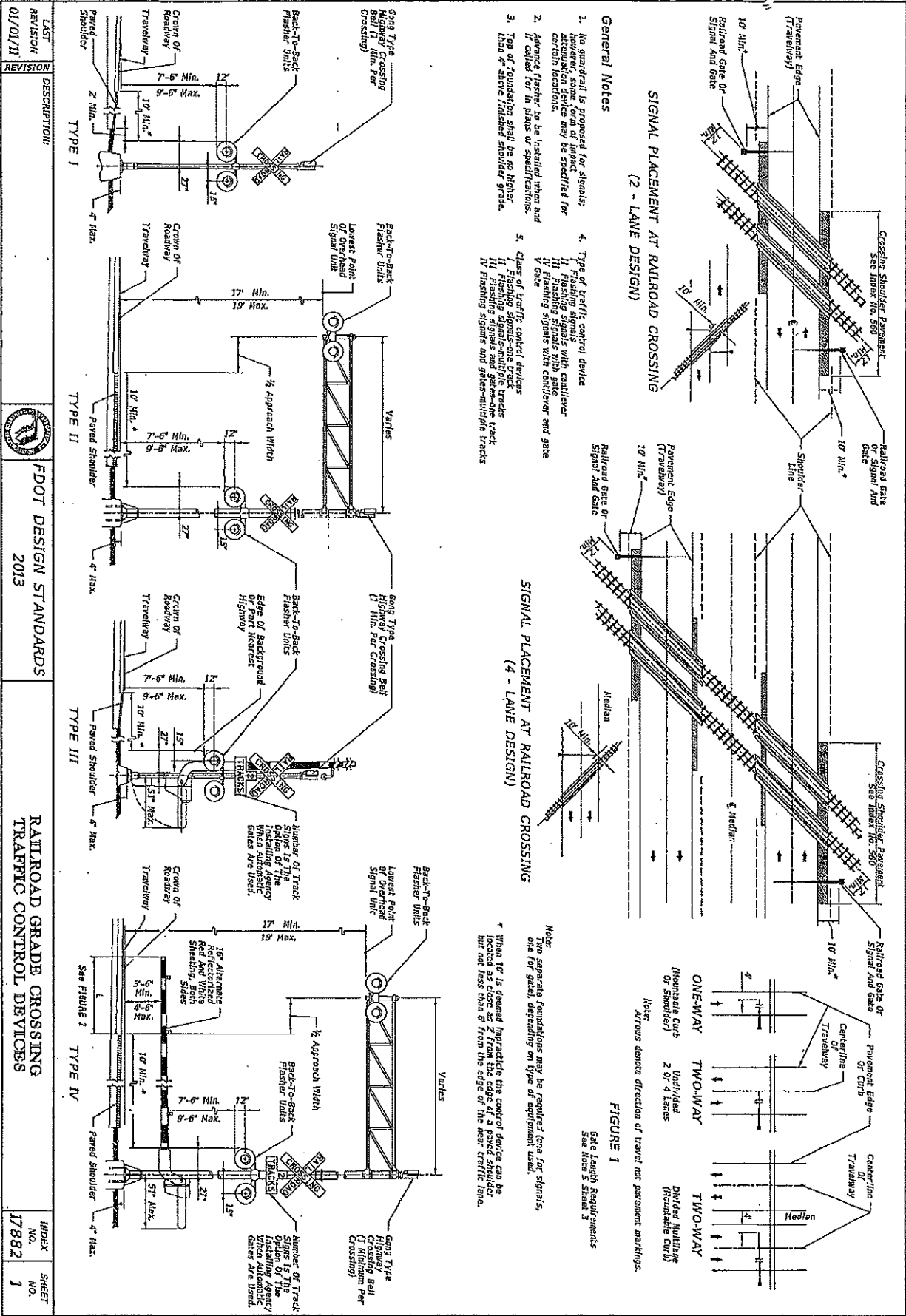

LAST REVISION	DESCRIPTION	INDEX NO.	SHEET NO.
01/01/11		17882	1

**FDOT DESIGN STANDARDS 2013**

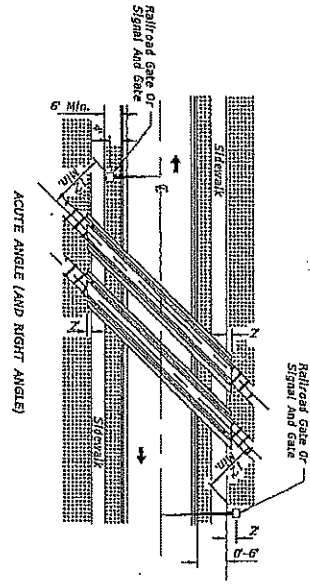

SIGNAL PLACEMENT AT RAILROAD CROSSING  
(2 LANES, CURB & GUTTER)  
ACUTE ANGLE (L&H RIGHT ANGLE)

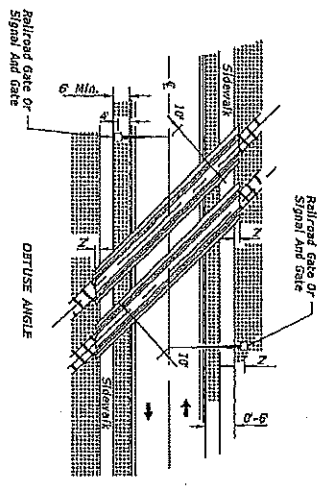

SIGNAL PLACEMENT AT RAILROAD CROSSING  
(2 LANES, CURB & GUTTER)  
OBTUSE ANGLE

- GENERAL NOTES**
1. The location of flashing signals and stop lines shall be established based on future (or present) installation of gate with appropriate tread clearances.
  2. Where plans call for railroad traffic control devices to be installed in curved medians, the minimum median width shall be 12'-6".
  3. Location of railroad traffic control devices is based on the distance available between face of curb & sidewalk, 0' to 6" - locate device outside sidewalk. Over 6" - locate device between face of curb and sidewalk.
  4. Stop line to be perpendicular to edge of roadway, approx. 15' from nearest rail, or 8' from end and parallel to gate when present.
  5. When a cantilever-arm flashing-light signal is used, the location of the signal shall be based on the location of the roadway to the lowest point of the Overhead Signal Unit.

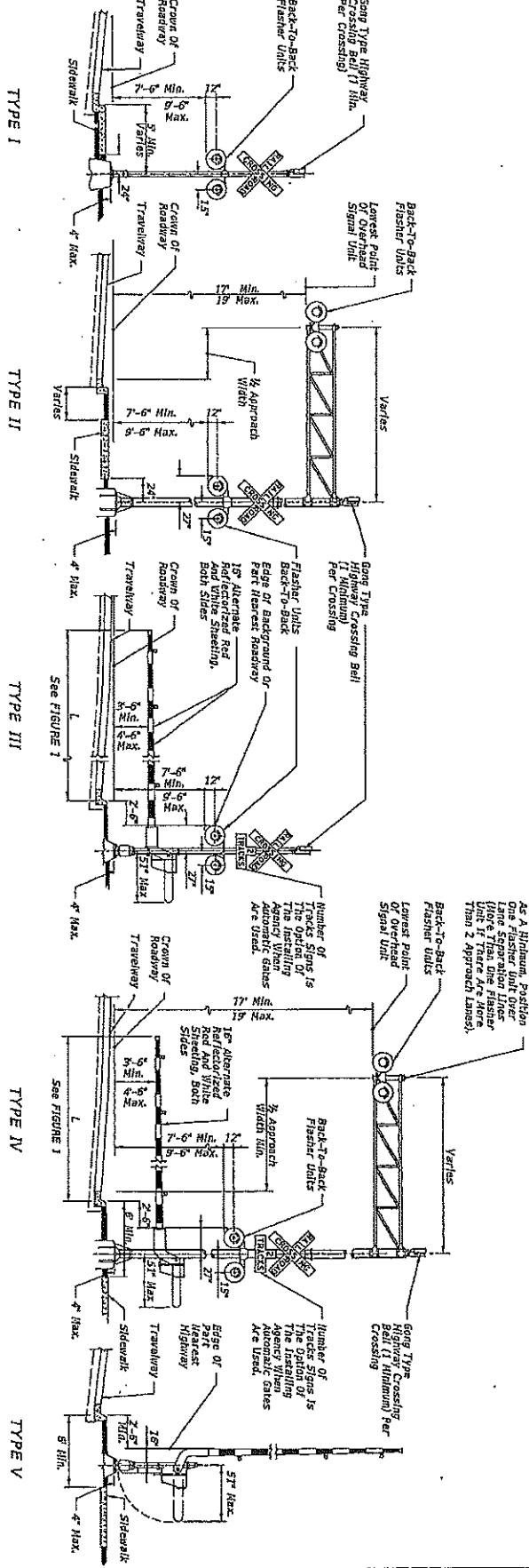

LAST REVISION	DESCRIPTION	INDEX NO.	SHEET NO.
01/01/11		17882	2

FDOT DESIGN STANDARDS  
2013

RAILROAD GRADE CROSSING  
TRAFFIC CONTROL DEVICES

RAILROAD CROSSING AT  
TWO (2)-LANE ROADWAY

RAILROAD CROSSING AT  
MULTILANE ROADWAY

RELATIVE LOCATION OF CROSSING TRAFFIC  
CONTROL DEVICES

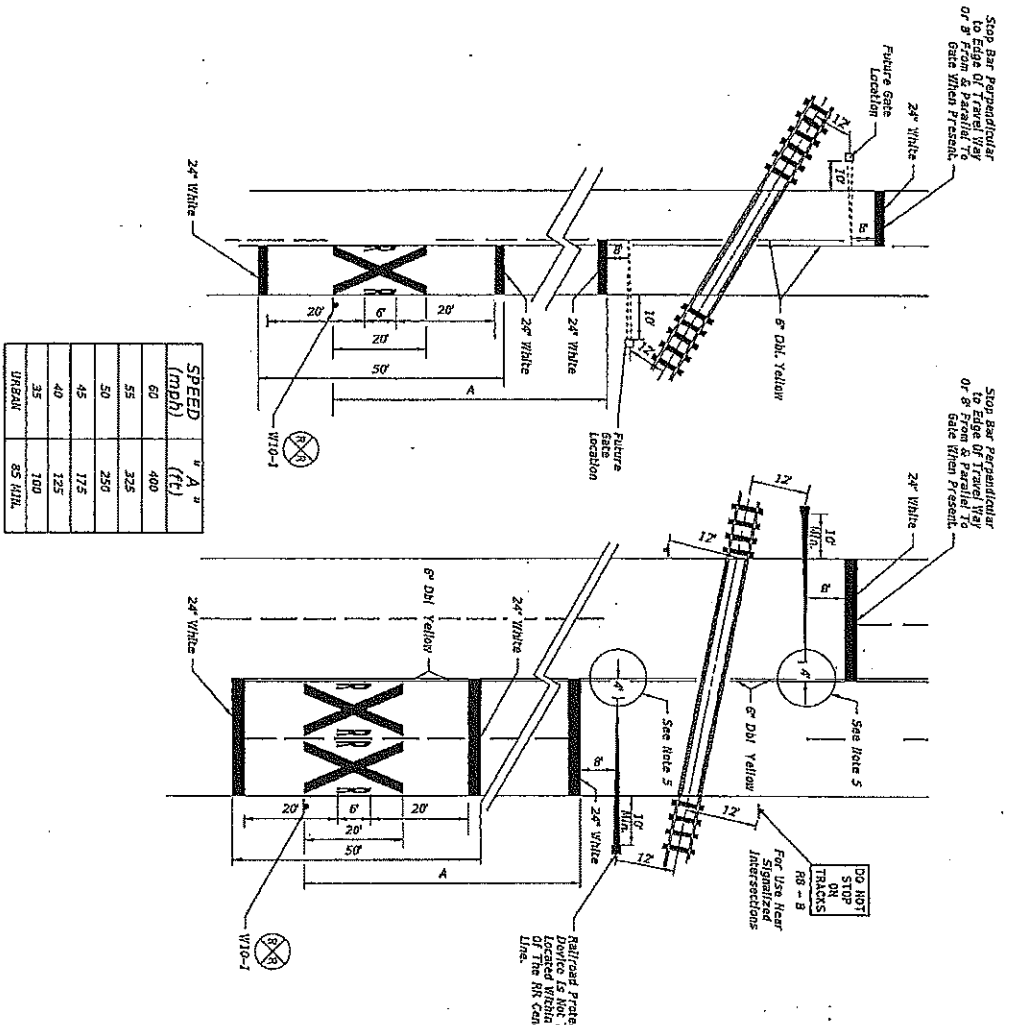

SPEED (mph)	"A"	"B"
60	400	
55	325	
50	250	
45	175	
40	125	
35	100	
UNRAV	85 MIN.	

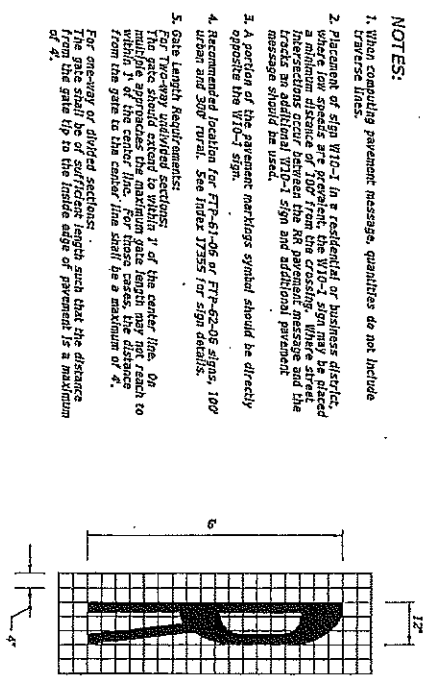
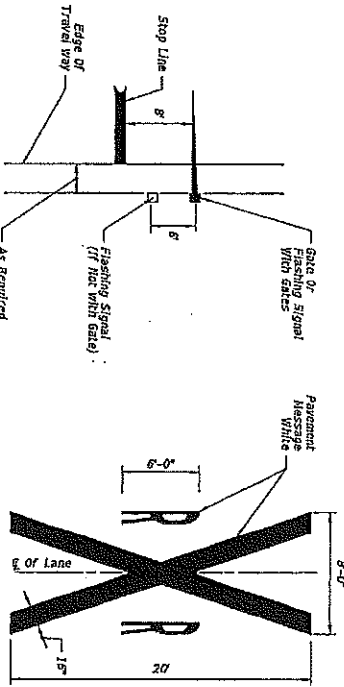

NOTES:

1. When conveying pavement messages, quantities do not include traverse lines.
2. Placement of sign W10-1 in a residential or business district, except for streets of 60' or less, the crossing sign may be placed in the center line of the roadway. The crossing sign shall be placed in the center line of the roadway between the RR pavement message and the tracks an additional W10-1 sign and additional pavement message should be used.
3. A portion of the pavement markings symbol should be directly opposite the W10-1 sign.
4. Recommended location for FTP-61-06 or FTP-62-06 signs, 100' urban and 300' rural. See Index 17355 for sign details.
5. Gate length requirements for two-lane roadways: The gate should extend to within 1' of the center line. On multiple approaches the maximum gate length may not reach to within 1' of the center line. For these cases, the distance from the gate to the center line shall be a maximum of 4'. For one-way or divided sections: The gate shall be of sufficient length such that the distance from the gate tip to the inside edge of pavement is a maximum of 4'.

LAST REVISION	DESCRIPTION:		FDOT DESIGN STANDARDS 2013	RAILROAD GRADE CROSSING TRAFFIC CONTROL DEVICES	INDEX NO.	SHEET NO.
07/01/10	REVISION				17882	3