

MEMORANDUM

Agenda Item No. 5(E)

TO: Honorable Chairman Esteban L. Bovo, Jr.
and Members, Board of County Commissioners

DATE: March 7, 2017

FROM: Abigail Price-Williams
County Attorney

SUBJECT: Resolution approving
amendment to the
Redevelopment Plan for the
North Miami Beach Community
Redevelopment Agency

The accompanying resolution was prepared by the Office of Management and Budget Department and placed on the agenda at the request of Prime Sponsor Government Operations Committee.

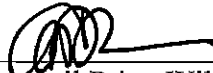

Abigail Price-Williams for
County Attorney

APW/lmp

Memorandum



Date: March 7, 2017

To: Honorable Chairman Esteban L. Bovo, Jr.
and Members, Board of County Commissioners

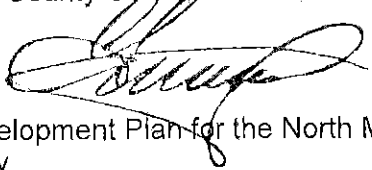
From: Carlos A. Gimenez
Mayor 

Subject: Approval of the Redevelopment Plan for the North Miami Beach Community
Redevelopment Agency

Recommendation

It is recommended that the Board of County Commissioners (Board) consider the attached resolution approving the North Miami Beach Community Amended Redevelopment Plan (Second Amended Plan) for the North Miami Beach Community Redevelopment Agency (Agency). The Second Amended Plan will not extend the life of the Agency beyond its current sunset date of October 11, 2028, nor will it amend the boundaries of the North Miami Beach Community Redevelopment Area (Area).

Scope

The Area lies within Commission Districts 2 and 4, which are represented by Commissioner Jean Monestime and Commissioner Sally Heyman, respectively.

Fiscal Impact / Funding Source

The Agency's revenue source is generated through the incremental growth of ad valorem revenues beyond an established base year, Tax Increment Financing (TIF), as defined in Section 163.387 of the Florida Statutes. County and City TIF funds are deposited into a trust fund for use in the Area.

The Agency was established in 2005. To date, the County has contributed a total of \$4.629 million, and the City of North Miami Beach (City) has contributed a total of \$6.766 million into the Agency's trust fund. It is estimated that the County will contribute approximately \$10.622 million and the City will contribute \$14.879 million from FY 2016-17 through 2028, which is when the Agency will sunset.

Track Record/Monitor

This item does not provide for contracting with any specific entity.

Background

In 1969, the Florida Legislature enacted the Act, as it is presently codified in Part III of Chapter 163 of the Florida Statutes, as amended. The Act authorizes counties and municipalities in Florida to create community redevelopment agencies to prepare redevelopment plans for certain defined areas within their boundaries designated as community redevelopment areas, within which community redevelopment projects may be undertaken to eliminate and prevent the development and spread of slum or blighted areas through the use of creative financing mechanisms.

On June 7, 2005, the Board adopted Resolution No. R-611-05 that established the Agency and approved the Agency's Community Redevelopment Plan (Plan) and Interlocal Agreement. The Board adopted Ordinance No. 05-110 on June 7, 2005, which provided a funding mechanism for implementation of the plan (Trust Fund). The Interlocal Agreement requires the Agency to submit for County approval an annual budget for the implementation of the Plan. On December 19, 2006, the Board adopted Resolution No. R-1427-06 allowing the Agency to enter into a loan for infrastructure improvements and property purchase not to exceed \$8 million, and extending the life of the Agency from 2015 to October 11, 2028. On May 15,

2012, the Board adopted Resolution No. R-429-12, which amended the Redevelopment Plan (the "Amended Plan") to include certain projects and redevelopment strategies.

The Area is located in the center of the North Miami Beach community. Specifically, the Area is generally bound on the north by NE 174 Terrace, on the south by NE 153 Street, on the east by Biscayne Boulevard and on the west by NE 8 Avenue.

The Second Amended Plan (Exhibit A) accomplishes the following:

- Reflects recent changes to the City's Comprehensive Plan and Zoning Codes;
- Removes outdated language and images;
- Updates financial projections;
- Updates program descriptions to reflect current policies and practices;
- Includes updated capital projects;
 - Rebuilding West Dixie from NE 163 Street to NE 173 Street including additional pedestrian and bicycle improvements;
 - Future Costal Link Rail Station along Biscayne Boulevard; and
 - Shared parking facilities along West Dixie Highway.
- Makes adjustments required by changes in State law;
- Includes a new Tax Increment Recapture Program to encourage private investment in the Area;
- Removes old programs no longer being utilized such as the Commercial Security Grant; and
- Incentivize a "Healthy Mix" of affordable, workforce, market, luxury and mixed income housing in the Area.

The Second Amended Plan was approved by the Agency on January 28, 2016 (Resolution R2016-2) Exhibit B and by the City on February 2, 2016 (Resolution R2016-7) Exhibit C. The acceptance of this Second Amended Plan does not modify the funding being contributed to the Agency by the County or City, expand or alter the CRA boundaries, nor does it extend the life of the Agency beyond the current expiration year of 2028.

The Tax Increment Financing and Coordinating Committee reviewed the CRA's Redevelopment Plan on April 26, 2016 and unanimously recommended it for Board approval.

Attachment

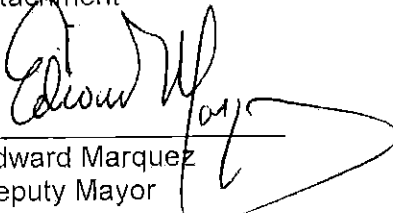
Edward Marquez
Deputy Mayor

Mayor00517

Exhibit A – Second Amended North Miami Beach Community Redevelopment Area Plan
Exhibit B – North Miami Beach Community Redevelopment Agency Resolution R 2016-2
Exhibit C – City of North Miami Resolution R 2016-7



MEMORANDUM

(Revised)

TO: Honorable Chairman Esteban L. Bovo, Jr.
and Members, Board of County Commissioners

DATE: March 7, 2017

FROM: Abigail Price-Williams
County Attorney

SUBJECT: Agenda Item No. 5(E)

Please note any items checked.

- "3-Day Rule" for committees applicable if raised
- 6 weeks required between first reading and public hearing
- 4 weeks notification to municipal officials required prior to public hearing
- Decreases revenues or increases expenditures without balancing budget
- Budget required
- Statement of fiscal impact required
- Statement of social equity required
- Ordinance creating a new board requires detailed County Mayor's report for public hearing
- No committee review
- Applicable legislation requires more than a majority vote (i.e., 2/3's ____, 3/5's ____, unanimous ____) to approve
- Current information regarding funding source, index code and available balance, and available capacity (if debt is contemplated) required

Approved _____ Mayor
Veto _____
Override _____

Agenda Item No. 5(E)
3-7-17

RESOLUTION NO. _____

RESOLUTION APPROVING AMENDMENT TO THE
REDEVELOPMENT PLAN FOR THE NORTH MIAMI BEACH
COMMUNITY REDEVELOPMENT AGENCY

WHEREAS, the Legislature of the State of Florida enacted the Community Redevelopment Act of 1969, which is presently codified in Part III of Chapter 163, Florida Statutes (the "Act"); and

WHEREAS, pursuant to the Act, a redevelopment plan must be adopted by the governing body to initiate redevelopment activities within the redevelopment area; and

WHEREAS, all powers arising through the Act are conferred upon counties with home rule charters; and

WHEREAS, on November 4, 2004, this Board adopted Resolution No. R-1345-04, which among other things (i) found the area in the City of North Miami Beach (the "City"), to be a "blighted area" within the meaning of Part III of Chapter 163, Florida Statutes ("Redevelopment Area"), and (ii) delegated to the City of North Miami Beach, pursuant to Section 163.410, Florida Statutes, the power to:

(a) make findings and determine the Redevelopment Area to be a slum and/or blighted area,

(b) make findings of necessity as to the rehabilitation, conservation, and/or redevelopment of the Redevelopment Area;

(c) create a community redevelopment agency and delegate powers to the agency, or declare itself as the agency with the power to exercise such powers assigned to the agency;

(d) initiate, prepare and adopt a plan of redevelopment and any amendments thereto, subject to the review and approval of the Board; and

WHEREAS, on February 1, 2005, the City adopted Resolution R2005-5 which approved the North Miami Beach Community Redevelopment Plan (the "Plan") and provided for the transmittal of the Plan to the County for further action; and

WHEREAS, on June 7, 2005, the Board enacted Ordinance No. 05-110, which created a North Miami Beach Community Redevelopment and Revitalization Trust Fund (the "Trust Fund"), and provided a funding mechanism for implementing the Plan; and

WHEREAS, on June 7, 2005, the Board adopted Resolution No. R-611-05, which approved the Plan and Interlocal Cooperation Agreement with the City and Agency ("Interlocal Agreement"); and

WHEREAS, on May 15, 2012, this Board adopted Resolution No. R-429-12, which amended the Redevelopment Plan (the "Amended Plan") to include certain projects and redevelopment strategies; and

WHEREAS, on January 28, 2016, the Agency adopted Resolution No. R2016-2, which is attached hereto as Exhibit B, which amended the Amended Plan (the "Second Amended Plan"), which is attached hereto as Exhibit A, and forwarded the Second Amended Plan to the City and County consideration; and

WHEREAS, on February 2, 2016, the City adopted Resolution No. 2016-7, which is attached hereto as Exhibit C, approving the Second Amended Plan and forwarding to the County for review and approval; and

WHEREAS, this Board desires to accomplish the purpose outlined in the accompanying memorandum, a copy of which is incorporated herein by reference,

NOW, THEREFORE, BE IT RESOLVED BY THE BOARD OF COUNTY COMMISSIONERS OF MIAMI-DADE COUNTY, FLORIDA, that:

Section 1. The foregoing recitations are incorporated in the body of this resolution by reference.

Section 2. The Second Amended Plan is approved, in substantially the form attached hereto as Exhibit A and incorporated herein by reference.

Section 3. If any one or more provisions of this resolution should be contrary to law or invalid or ineffective for any reason, such provision shall be deemed severable from, and shall not affect the validity of, the remaining provisions of this resolution.

The foregoing resolution was offered by Commissioner who moved its adoption. The motion was seconded by Commissioner and upon being put to a vote, the vote was as follows:

Esteban L. Bovo, Jr., Chairman	
Audrey M. Edmonson, Vice Chairwoman	
Bruno A. Barreiro	Daniella Levine Cava
Jose "Pepe" Diaz	Sally A. Heyman
Barbara J. Jordan	Joe A. Martinez
Jean Monestime	Dennis C. Moss
Rebeca Sosa	Sen. Javier D. Souto
Xavier L. Suarez	

The Chairperson thereupon declared the resolution duly passed and adopted this 7th day of March, 2017. This resolution shall become effective upon the earlier of (1) 10 days after the date of its adoption unless vetoed by the County Mayor, and if vetoed, shall become effective only upon an override by this Board, or (2) approval by the County Mayor of this Resolution and the filing of this approval with the Clerk of the Board.

MIAMI-DADE COUNTY, FLORIDA
BY ITS BOARD OF
COUNTY COMMISSIONERS

HARVEY RUVIN, CLERK

By: _____
Deputy Clerk

Approved by County Attorney as
to form and legal sufficiency.

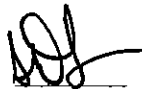

Shannon Summerset-Williams

2015

North Miami Beach CRA Redevelopment Plan



North Miami Beach Community
Redevelopment Agency ("CRA")
17050 NE 19th Avenue – Room 122
North Miami Beach, FL 33162
NMB CRA.org • (305) 787-6053

Contents

Acknowledgements..... 4

Introduction 5

General Description of the Redevelopment Area..... 6

 Redevelopment Area Map 6

 Location and Description of the Redevelopment Area..... 6

Creation, Severability, and Powers of the Community Redevelopment Agency..... 7

 Creation of the Community Redevelopment Agency (the "Agency" or "CRA") 7

 About the Board..... 8

 About the Board Meetings..... 8

 Life of the Agency..... 8

 Interlocal Agreement between the City, the CRA, and Miami-Dade County..... 9

 The Agency as a Florida Dependent Special District 10

 CRA Website to comply with Florida Dependent Special District Statute 10

 Powers of the Agency 10

 Powers Withheld from the Agency 10

Authority to Undertake Redevelopment 11

Finance and Budget..... 12

 Finance and Budget Process 12

 Tax Increment Financing ("TIF") Projections..... 12

 Projecting TIF Revenues: How TIF Works..... 12

 Five and Twelve-Year Projected Annual TIF Revenues 12

Bonding Authority 13

Allocation and Expenditure of Non-Bond Related TIF Revenue 14

Administration 14

 Status of the Long Term Debt 14

Capital Improvement Program..... 15

 Capital Improvement Program Policy and Strategy..... 15

 Capital Improvement Program Planned and Ongoing Projects 15

 West Dixie Highway Road and Bridge Improvements 15

 Coastal Link Rail Station 16

 Shared Parking Facilities..... 16

 Wayfinding Signage for the CRA 17

10

Hanford Boulevard Maintenance.....	17
Land Acquisition Policy, Strategy and Protocols.....	18
Areawide Programs and Tools	24
Economic Development and Job Creation Programs.....	24
Beautification and Appearance Improvement.....	26
Specific Projects and Programs to Advance.....	28
Infrastructure Improvement Programs.....	30
Environmental Clean-up Programs	31
Redevelopment Advocacy.....	32
Code Enforcement Enhancement	32
Community Policing Innovations.....	33
Housing Policies and Programs	33
Safeguards to Ensure Redevelopment Activities Follow the Plan	34
Safeguards to Ensure Financial Accountability	34
Safeguards to Ensure Proper Implementation and Project/Program Accountability.....	35
Safeguards Through the Retention of Powers by the City and the County.....	35
Community Redevelopment Agency Goals, Objectives and Policies.....	36
Encouragement of Private Enterprise.....	36
Compliance with the City of North Miami Beach Comprehensive Plan and Land Development Regulations.....	36
Goals, Objectives and Policies.....	37
Redevelopment Plan Amendment Process.....	50
Neighborhood Impact of Programs.....	53
Land Use, Zoning and Development Approvals	53
Effect on Traffic.....	53
Effect on Community Facilities.....	53
Effect on Schools.....	53
Appendix A – Interlocal Agreement.....	54
Appendix B - Legal Description	55
Appendix C – West Dixie Highway Implementation Strategy.....	58

Acknowledgements

North Miami Beach Community Redevelopment Agency Board

George Vallejo, Chairman
Anthony DeFillipo, Commissioner
Phyllis S. Smith, Commissioner
Beth E. Spegel, Commissioner
Frantz Pierre, Commissioner
Barbara Kramer, Commissioner
Marlen Martell, Commissioner

North Miami Beach City and Community Redevelopment Agency Staff

Ana M. Garcia, City Manager and Executive Director
Jose Smith, City Attorney
Candido Sosa-Cruz, Assistant City Manager
Sarah Johnston, Assistant City Attorney
Steven Zelkowitz, CRA Attorney
Patrick Brett, CRA Administrator

2015 Update Prepared by:

RMA, LLC

Ken Stapleton & Associates

Introduction

One of the driving factors generating the need for this 2015 Community Redevelopment Plan Amendment ("2015 Plan Amendment") is the condition of the economy. Currently (2015), the national and North Miami Beach area economies are actively recovering from the effects of a severe economic retraction and a series of systemic problems in the credit markets. Market demand is strong for walkable urban places in South Florida, and the North Miami Beach Community Redevelopment Agency ("CRA" or "Agency") Redevelopment Area is well positioned to take advantage of this current window of opportunity for private investment, especially in light of the recent amendments to the City's Comprehensive Plan and Zoning Code.

Therefore, the Agency's role as an economic catalyst will be magnified for the next 24-48 months. All public stimulus infusion to private sector markets must be timely.

This 2015 Plan Amendment to the North Miami Beach Community Redevelopment Plan ("CRA Plan") was necessary to:

- Adjust to reflect recent changes to the Comprehensive Plan and Zoning Code;
- Remove outdated language and images;
- Update financial projections;
- Update program descriptions to reflect current policies and practices;
- Integrate West Dixie Highway implementation plan activities (located in Appendix "D");
- Make any adjustments required by changes in State law;
- Highlight current priority projects.

This 2015 Plan Amendment is important because all projects, programs, and spending must be consistent with the CRA Plan, the CRA Plan must be consistent with the City's Comprehensive Plan, and the plan must reflect the new shared vision for the Redevelopment Area.

A New Bold Vision



General Description of the Redevelopment Area

Redevelopment Area Map



Location and Description of the Redevelopment Area

The North Miami Beach Community Redevelopment Agency focuses redevelopment efforts with the Redevelopment Area ("Redevelopment Area") which is approximately 468 acres and includes the center of the North Miami Beach community. The major East/West highway, State Road 826/NE 163rd Street/North Miami Beach Boulevard, is within the CRA.

The Redevelopment Area extends approximately two miles West from Biscayne Boulevard to NE 8th Avenue along North Miami Beach Boulevard.

The North/South centerline is NE 15th Avenue, from NE 171st Street (the intersection of NE 15th Avenue and the Snake Creek Waterway) South to NE 161st Street. The Mall at 163rd Street, Walmart, and Home Depot, are located just West of NE 15th Avenue and just North of NE 163rd Street, are not within the City's boundaries, and therefore not within the Redevelopment Area.

The Redevelopment Area also extends along West Dixie Highway from NE 154th Street to approximately 175th Street. The area along West Dixie Highway from 163rd Street to 173rd Street was the focus on the CRA's 2015 West Dixie Highway Implementation Plan, which was incorporated into this 2015 Plan Amendment in Appendix "D."

On the East, the Redevelopment Area is bounded for the most part by the East right-of-way line of Biscayne Boulevard (U.S. Route 1).

Creation, Severability, and Powers of the Community Redevelopment Agency

Creation of the Community Redevelopment Agency (the "Agency" or "CRA")
The Agency was created and adopted its initial CRA Plan in 2005.

A brief history of the Agency's evolution is as follows:

September 14, 2004

North Miami Beach City Council adopted Resolution No 2004-57 providing a finding of necessity declaring that a blighted area as defined in Section 163.340, *Florida Statutes* existed within the City's boundaries and further declaring that the rehabilitation, conservation, redevelopment, or a combination thereof, of this area was necessary and in the interest of public health, safety, morals, and welfare of the residents of the City.

November 30, 2004

Miami-Dade County adopted Resolution R1345-04 declaring that a slum or blighted area existed in the geographic area, described by map and legal description, and determined that it was necessary to redevelop the Redevelopment Area in accordance with the provisions of, Chapter 163, Part III, *Florida Statutes* and delegated to the North Miami Beach City Council the authority to exercise the redevelopment powers conferred upon the Board within the Redevelopment Area in accordance with Chapter 163, Part III, *Florida Statutes* to enable the City Council to declare the need for, creation of and delegation of powers to a community redevelopment agency, and to initiate, prepare and adopt a plan of redevelopment for final approval by Miami-Dade County.

December 21, 2004

The North Miami Beach City Council adopted Resolution R2004-86 accepting a delegation of powers from Miami-Dade County. Resolution R2004-86 established a need and created the Agency, declared the City Council as the Agency, and granted the Agency the power to exercise all powers permitted by Chapter 163, Part III, *Florida Statutes*. Miami-Dade County directed the initiation, preparation, and adoption of a CRA Plan by the Agency.

February 5, 2005

The North Miami Beach City Council adopted Resolution R2005-05 giving final approval to the CRA Plan.

June 7, 2005

Miami-Dade County approved the North Miami Beach CRA Plan. The CRA Plan was initially granted a 10-year life. Miami-Dade County adopted Ordinance 05-110 to create a community redevelopment trust fund.

October 11, 2005

An Interlocal Agreement between Miami-Dade County, the City of North Miami Beach, and the North Miami Beach Community Redevelopment Agency was executed. A copy of the formal and complete Interlocal Agreement is included in this 2015 Plan Amendment as Appendix "A."

November 21, 2006

Subsequently, the North Miami Beach CRA (Resolution R2006-48) and Miami-Dade County (Relevant to CRA Plan, Resolution 611-05, Relevant to Trust Fund, Ordinance 05-110, Relevant to Revenue Note, Resolution 1427-06) adopted legislation approving the issuance of two loans, and Miami-Dade County approved the extension of the life of the Agency to coincide with the schedule for repayment of the loans.

About the Board

The Agency is a public body corporate and politic. The composition of the Community Redevelopment Agency board members (the "Board" or "Commissioners" or "Board of Commissioners") shall adhere to the requirements established in Sections 163.356 and 163.357, *Florida Statutes*. Currently, the City's seven member City Council serves as the Agency's Board of Commissioners with the Mayor being the Chairperson and the Vice-Mayor being the Vice-Chair.

About the Board Meetings

All meetings of the CRA Board shall be open to the public and governed by the provisions of Chapter 286, *Florida Statutes*.

Life of the Agency

The adoption of this plan shall trigger terms of Sections 163.387(2) (a) and 163.362(10), *Florida Statutes*. This 2015 Plan Amendment does not extend the life of the Agency because the Agency's sunset is governed by an Interlocal Agreement amongst the City of North Miami Beach, Miami-Dade County, and the CRA.

163.387(2)(a). Except for the purpose of funding the trust pursuant to subsection (3), upon the adoption of an ordinance providing for funding of the redevelopment trust fund as provided in this section, each taxing authority shall, by January 1 of each year, appropriate to the trust fund for so long as any indebtedness pledging increment revenues to the payment thereof is outstanding (but not to exceed 30 years) a sum that is no less than that increment as defined and determined in subsection (1) or paragraph (3)(b) accruing to such taxing authority. If the community redevelopment plan is amended or modified pursuant to s. 163.361(1), each such taxing authority shall make the annual appropriation for a period not to exceed 30 years after the date the governing body amends the plan but no later than 60 years after the fiscal year in which the plan was initially approved or

adopted. However, for any agency created on or after July 1, 2002, each taxing authority shall make the annual appropriation for a period not to exceed 40 years after the fiscal year in which the initial community redevelopment plan is approved or adopted.

163.362(10). Provide a time certain for completing all redevelopment financed by increment revenues. Such time certain shall occur no later than 30 years after the fiscal year in which the plan is approved, adopted, or amended pursuant to s. 163.361(1). However, for any agency created after July 1, 2002, the time certain for completing all redevelopment financed by increment revenues must occur within 40 years after the fiscal year in which the plan is approved or adopted.

Interlocal Agreement between the City, the CRA, and Miami-Dade County

The Interlocal Agreement between the City of North Miami Beach, Miami-Dade County, and the CRA was executed and effective in 2005 and is located in Appendix "A."

The Interlocal Agreement delineates the delegation of powers as provided in Section 163.370, *Florida Statutes* and delineates powers retained and required approvals by the North Miami Beach City Council and Miami-Dade County. The Interlocal Agreement establishes the term of the Agency, procedures for coordination between the County and the City/Agency, and delineates required approval procedures for certain redevelopment activities and for the Agency's annual budget.

A summary of conditions and requirements is listed below:

Implementation of Plan

All CRA Plan amendments and supplements must be approved by the Miami-Dade County before they come into effect.

The CRA Plan, as approved by the Miami-Dade County initially in 2005 was for a period of ten (10) years. Subsequently, the life of the Agency was extended to the year 2028.

Establishes a cap of 20% of funds to be used for total administrative expenses, and no more than 6% to be allocated to indirect and overhead expenses.

Establishes a "County Administrative Fee" to be charged annually.

City/County Coordination

Provides for the County to designate a Redevelopment Area Coordinator to serve as the County's liaison to the City and the Agency.

Requires County approval with regard to indebtedness, bond financing, acquisition, disposition, and relocation activities.

Requires submission and approval procedures for the Agency's annual budget.

Land disposition

Requires that any disposition of land shall be accomplished in accordance with applicable provisions of federal, state, local law, the Plan, and the Interlocal Agreement.

Other Redevelopment Area Activities

Addresses relocation activities, requiring adherence to procedures set forth in the Uniform Relocation Assistance and Real Property Acquisition Policies Act.

The Agency as a Florida Dependent Special District

The CRA is a dependent special district and governed by Chapter 189, *Florida Statutes*. The CRA shall have filed no less annually a schedule of its regular meetings in compliance with Section 189.015, *Florida Statutes*.

CRA Website to comply with Florida Dependent Special District Statute

The Agency shall create and maintain a web site in compliance with Section 189.069, *Florida Statutes*.

Powers of the Agency

The powers of the Agency shall remain in compliance with Chapter 163, Part III, *Florida Statutes* and are additionally governed by the Interlocal Agreement attached as Appendix "A."

Powers Withheld from the Agency

These powers shall be vested in the City Council unless specifically assigned by the Miami-Dade County under the Interlocal Agreement:

The power to determine an area to be appropriate for Community Redevelopment.

The power to grant final approval to the CRA Plan amendments and modifications.

The power to authorize the issuance of revenue bonds or debt instruments.

The power to approve the development of community policing innovations.

The power to approve the acquisition, demolition, removal, or disposal of property as provided in Section 163.370(3), *Florida Statutes*, and the power to assume responsibility to bear loss as provided in Section 163.370(3), *Florida Statutes*.

The power to zone or rezone or make exceptions from building regulations or to enter into agreements with a housing authority.

The power to close, vacate, plan, or re-plan streets, roads, sidewalks, ways, or other places, and to plan or re-plan any part of the City.

Authority to Undertake Redevelopment

The 2015 Plan Amendment was prepared in accordance with the Community Redevelopment Act, Chapter 163, Part III, *Florida Statutes*. The adoption of this 2015 Plan Amendment, and any subsequent modifications or amendments, shall follow the procedures as required by public hearings and the adoption of the necessary resolutions and ordinances.

In recognition of the need to prevent the spread of and eliminate the existence of slum and blighted conditions within the community, the Community Redevelopment Act confers upon counties and municipalities the authority and powers to carry out "Community Redevelopment Activities." For purposes of the CRA Plan, the following definitions as provided in Chapter 163, Part III, *Florida Statutes*, shall apply:

"Community Redevelopment or redevelopment means undertakings, activities or projects of a county, municipality or Community Redevelopment Agency in a Community Redevelopment Area for the elimination and prevention of the development or spread of slums and blight for the provision of affordable housing, whether for rent or sale, to residents of low or moderate income, including the elderly, and may include slum clearance and redevelopment in a Community Redevelopment Area, or any combination or part thereof, in accordance with a Community Redevelopment plan and may include the preparation of such a plan."

Finance and Budget

Finance and Budget Process

The Agency's primary revenue source is generated through Tax Increment Financing ("TIF") as defined in Section 163.387, *Florida Statutes*. In addition to TIF, the Agency shall have the authority to pursue public funding through grants and loans, and private revenue through loans, contributions, disposal of any real property, mortgages, hypothecation, bond anticipation notes, lines of credit, and bond issues backed primarily by TIF. For purposes of successfully implementing the redevelopment strategy as presented, it is imperative to have a fully funded (at least 50% as per statute) TIF mechanism for the life of the Agency as established by the latest CRA Plan adopted by the City. Under certain conditions, the law allows a CRA to extend its life as well as the maturity date of its bonds. It should be understood that the purpose of this updated and Amended Plan is not to extend the life of the Agency or its supporting TIF funding mechanism.

Tax Increment Financing ("TIF") Projections

The CRA was established in 2005 and the County approval was initially for a period of 10 years, and was subsequently extended to the year 2028 by subsequent County action.

Projecting TIF Revenues: How TIF Works

Annual Tax-Increment Financing ("TIF") revenues are determined utilizing the formula delineated by *Florida Statutes*. A simple "straight-line" version of this formula is depicted on the following page. Other factors such as historic growth trends and market conditions can be interpolated to project future TIF growth.

Five and Twelve-Year Projected Annual TIF Revenues

It is important for any future planning that the CRA Board of Commissioners has up to date TIF projections. This will serve as vital information to assist the CRA Board when entering into multi-year commitments. It will also provide a basis upon which to negotiate public-private partnerships and in preparing annual budgets. This 2015 Plan Amendment delineates all investment and leverage strategies that are allowable under the governing State Statutes for redevelopment agencies. While it is imperative

YEAR	City TIF	County TIF	Total TIF
2015/16	\$504,541	\$356,569	\$861,110
2016/17	\$563,959	\$398,561	\$962,520
2017/18	\$625,160	\$441,813	\$1,066,973
2018/19	\$688,196	\$486,363	\$1,174,559
2019/20	\$1,294,207	\$914,643	\$2,208,850
2020/21	\$1,857,232	\$1,312,544	\$3,169,776
2021/22	\$1,957,231	\$1,383,215	\$3,340,446
2022/23	\$2,146,062	\$1,516,666	\$3,662,728
2023/24	\$3,011,830	\$2,128,522	\$5,140,353
2024/25	\$3,258,665	\$2,302,965	\$5,561,630
2025/26	\$3,519,075	\$2,487,003	\$6,006,077
2026/27	\$3,793,808	\$2,681,162	\$6,474,970
2027/28	\$4,083,651	\$2,886,000	\$6,969,651

that the Agency avail itself to these investment vehicles, it is also important to monitor the impending federal initiatives to provide infrastructure funding as part of a comprehensive economic stimulus package.

The Agency should utilize its TIF resources to maximize its potential to deliver revenue for the City. This plan recognizes that the statutorily defined time limitations on the life of the TIF mechanism, the ability to secure an investment grade bond rating as well as bond insurance, and other existing Agency financial obligations may impede the Agency's ability to generate capital through traditional debt instruments. A more innovative set of strategies may be required to generate capital.

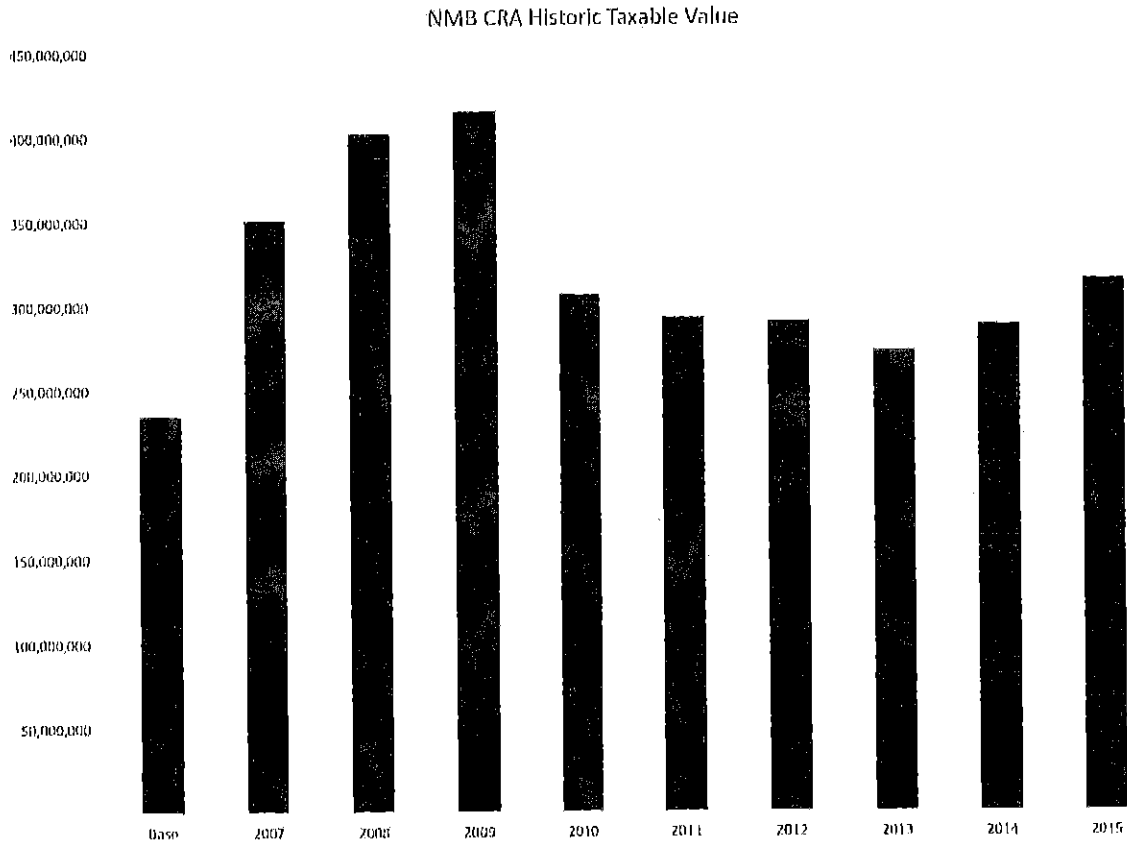

Bonding Authority

The Agency has the authority, subsequent to the approval of the City Council and the Miami-Dade County to issue redevelopment bonds which pledge the annual TIF revenue stream as the source of repayment. The Agency shall have the authority granted by Section 163.385 *Florida Statutes* at the time of bond or any debt instrument issuance.

It is the intent of the CRA Plan to provide maximum flexibility with regard to the financial arrangements and deal structures, which utilize these funds for capital investment. The Agency intends to use full authority granted by this Plan and Chapter 163, *Florida Statutes*, and all covenants delineated in an Official Statement that will be prepared to govern any bond issue.

Further, the Agency intends to utilize the maximum term of life for the TIF mechanism as provided in Sections 168.387(2)(a) and 163.362(10), *Florida Statutes*.

Allocation and Expenditure of Non-Bond Related TIF Revenue

As prescribed in the Powers section of this 2015 Plan Amendment the Agency shall have the authority to expend funds for all professional and administrative services necessary to carry out the implementation of the redevelopment strategies and programs in this Plan. In addition, the Agency is authorized to expend funds for completion of audits and other statutorily required reports with TIF revenue. The Agency shall also prepare a budget on an annual basis, which addresses the expenditure of all TIF trust fund revenues.

If workable, the annual CRA budget should be prepared and adopted in accordance with the City's budget authorization, the same schedule, public hearings, workshops, and legal notices. All TIF funds shall be expended or encumbered as set forth in Section 163.387, *Florida Statutes*. Any funds not expended in a fiscal year shall be allocated as prescribed by Section 163.387(7)(a-d), *Florida Statutes*.

Administration

The Agency may incur costs for management and administration activities. The Agency will be empowered to pay costs associated with management and administration of the Agency, including but not limited to, salaries and benefits for staff, operating supplies, vehicles, professional consulting, legal, engineering services, software, and equipment.

Status of the Long Term Debt

The CRA initiated and received required approval from Miami-Dade County (R-1427-06, Dec. 19, 2006) to issue two lines of credit totaling \$8 million to fund redevelopment projects; one to fund \$3 million in infrastructure and street improvements and reconstruction of streets within the Redevelopment Area, and the remaining line of credit of \$5 million to fund acquisition of property for future Transit Oriented Development ("TOD") in partnership with Miami-Dade Transit ("MDT").

The latter \$5 million project was not accomplished and as a result the CRA reallocated funds to be used for much needed infrastructure improvements and acquisition of commercial property for redevelopment. In April 2012, the Miami-Dade County Board of County Commissioners ("County") approved the use of the revenue from the line of credit for infrastructure improvements (\$4 million) and land purchase (\$1 million). In 2014, due to the downturn in the real estate market and reductions in tax increment revenues to pay debt service the CRA Board approved and repaid the remaining loan proceeds of \$3,672,500 from the 2007 line of credit. The \$5 million line of credit was closed and paid in full.

The \$3 million project was completed. The commercial business loan has a principal balance of approximately \$2 million as of November 1st, 2015, and a maturity date of February 1st, 2027, and bearing an interest rate of 1.612%. The loan revenues were primarily used for the construction and enhancement of Hanford Boulevard (NE 164th Street – Phase 4). Other uses of the funds included improvements at the Arthur I. Snyder Tennis Complex on West Dixie Highway and the Julius Littman Performing Arts Theatre on NE 19th Avenue.

Capital Improvement Program

Capital Improvement Program Policy and Strategy

The Agency Capital Improvement Program ("CIP") shall be considered a "living" document. It will evolve to ensure and allow the Agency to respond to the needs and opportunities that best serve the citizens, taxpayers, businesses, and the overall Redevelopment Area community. This section of the CRA Plan sets forth an initial list of select ongoing improvement projects and land acquisition areas of priority. Some projects, those with well-defined and agreed upon public purposes that are consistent with the CRA Plan, would be appropriate candidates for public investment through the CRA. The project pages in this section include project summaries as well as preliminary general cost estimates for CRA capital expenditures. Some projects will require additional financial participation by other entities. Actual funding allocations for projects will be determined annually through the budget process, and must be approved by the CRA Board.

Capital Improvement Program Planned and Ongoing Projects

West Dixie Highway Road and Bridge Improvements

DESCRIPTION: This project will rebuild West Dixie Highway between NE 163rd Street and NE 173rd Street, including the creation of a signature bridge over the Snake Creek Canal. County/MPO funding has been allocated, and designs will be guided by the recently adopted updates to the North Miami Beach Comprehensive Plan and Zoning Code.

STUDY: The CRA desires to have the improvements adhere and conform to the West Dixie Highway Implementation Strategy found in Appendix "D."

BUDGET: A total of \$12.5 million has been allocated to this project by the County, but additional pedestrian/bicycle improvements, related shared parking, and enhancements for a signature bridge may require limited additional CRA funding.

SCHEDULE: Project design is expected to begin in 2015 with construction occurring between 2016 and 2018.

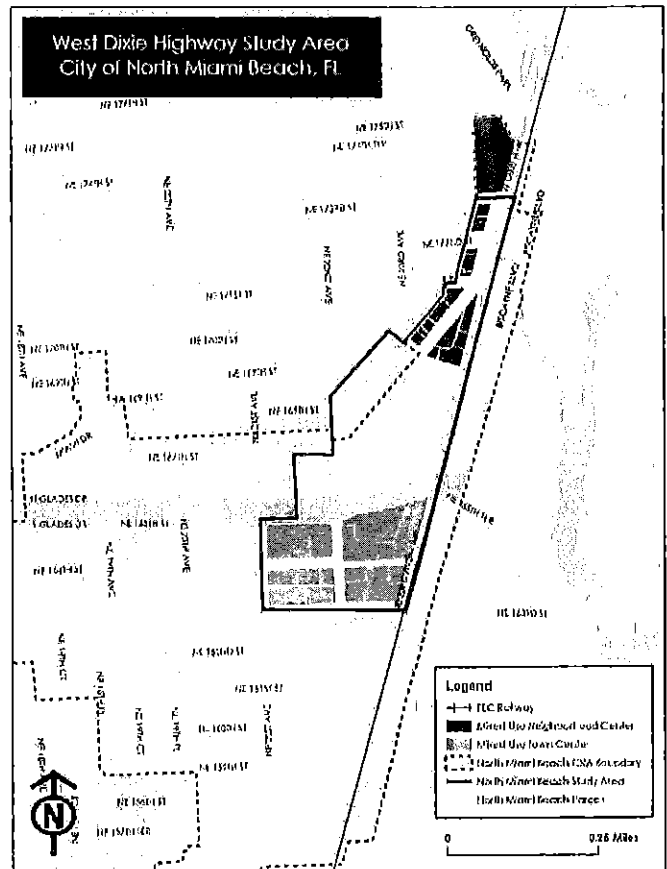

Coastal Link Rail Station

DESCRIPTION: This project will create a new commuter rail station at the eastern end of Fulford Avenue just west of Biscayne Boulevard in partnership with RTA/TriRail.

BUDGET: No formal budget has been created for this specific station, but the overall Coastal Link System Construction Budget is approximately \$800 million. It is likely that the CRA will need to invest in the station at some point in the future, but the needed amount is not clear.

SCHEDULE: The design and the construction of the station will depend on the timing of State and Federal funding. No formal project schedule has been approved as of November 2015.

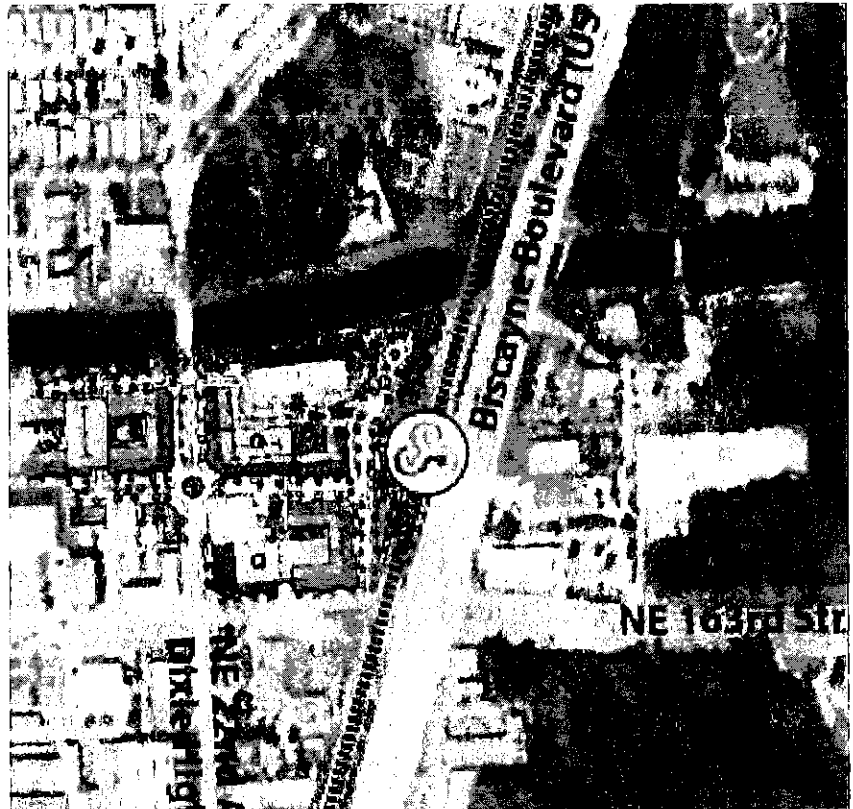

Shared Parking Facilities

DESCRIPTION: These projects will create new shared parking facilities to serve the West Dixie Highway Corridor North of 163rd Street and other areas within the Redevelopment Area in order to support smaller businesses and development projects.

BUDGET: No formal design or budget has been created for these specific projects, but it is likely that the CRA will need to invest in shared parking at some point in the near future along with private property owners. The needed amounts are not clear yet.

SCHEDULE: The initial shared parking project for West Dixie will likely be designed in parallel with the roadway and bridge designs during 2016 and 2017. Construction will depend on the progress of private developments in the area.

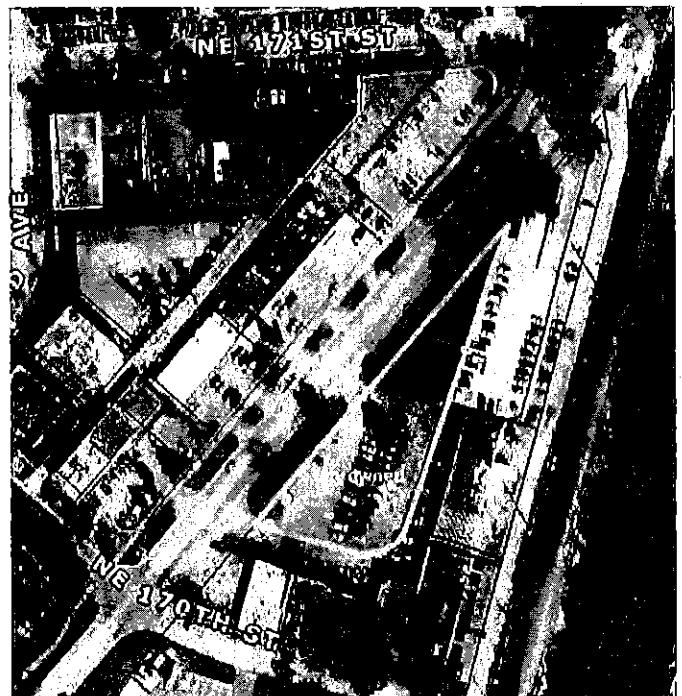

Potential area of shared parking facilities

24

Wayfinding Signage for the CRA

This project will create new way finding signage and clearly mark public parking, public facilities, and other key locations.

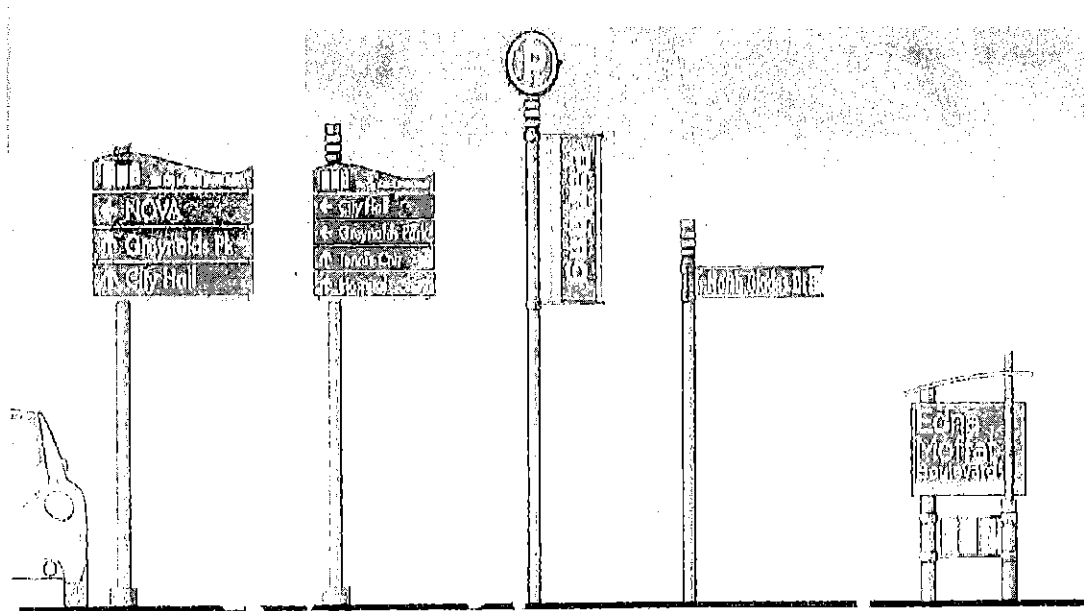

Hanford Boulevard Maintenance

Hanford Boulevard was reconstructed by the City and CRA to serve as the "Main Street" centerpiece of Fulford, and it is now beginning to attract private, mixed-use development. The CRA will maintain the improvements.

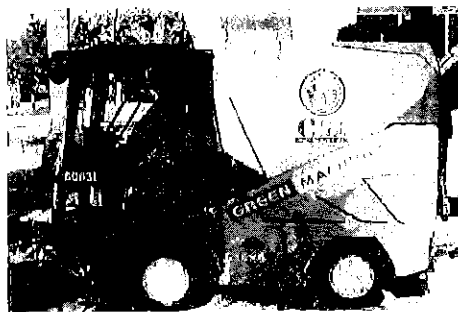

Areawide Commercial Improvement Programs

The CRA, under the CRA Plan and Chapter 163, Part III, *Florida Statutes*, may provide financial assistance to qualified owners of commercial properties located within the Redevelopment Area for eligible building or site improvements that contribute to the physical, economic, social, and aesthetic enhancement of the Redevelopment Area. The CRA has two commercial programs: Commercial Property Improvement Grant and the Façade Beautification Grant Program, the CRA seeks to help businesses improve the attractiveness of properties, and thereby work to achieve the Agency's goal of eliminating conditions that have a negative impact on private investment and economic growth. All improvements must be in compliance with any and all applicable codes, design standards, and all other restrictions of the City of North Miami Beach. Every applicant must be approved by the CRA, and is subject to fund availability.

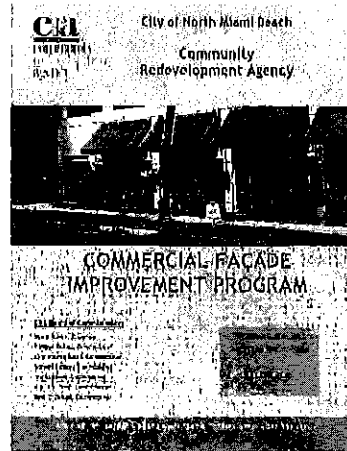

Tax Increment Recapture Program

The CRA, under the CRA Plan and Chapter 163, Part III, *Florida Statutes*, may provide financial assistance to qualified owners of commercial properties located within the Redevelopment Area for eligible building or site improvements that contribute to the physical, economic, social, and aesthetic enhancement. Through the Tax Increment Recapture Program (please see Appendix "C"), the CRA seeks to encourage private investors and developers to build or expand commercial and mixed-use projects that support one or more public policy goals important to the implementation of the CRA Plan and consistent with the City's Comprehensive Plan and Zoning regulations. Such enhancements may include, but are not limited to: inclusion of prioritized or targeted uses; job creation; stimulative activities; open space or infrastructure improvements; transit oriented development; public parking; public art; and Green Building features.

Land Acquisition Policy, Strategy and Protocols

The acquisition of land should be a strategic measure to help ensure that the Redevelopment Area evolves in a coordinated and desirable manner. The strategy shall also avail itself of market conditions.

The future redevelopment within the Redevelopment Area may necessitate land acquisition and all other redevelopment actions allowable under the State Statute and the Interlocal Agreement to effectively redevelop privately owned properties. As redevelopment projects develop in the future, the CRA will document specific land/building acquisition needs and attempt to acquire necessary lands and/or buildings through public/private development partnerships or private market purchases. The CRA may commission a land acquisition projection report in 5 (five) year intervals based upon redevelopment activities and needs within the Redevelopment Area.

The CRA shall adhere to all statutory requirements as set forth in Section 163.380, *Florida Statutes*, with regard to the acquisition and disposition of property in the Redevelopment Area. In addition to this governing statutory requirement, the Agency shall also adhere to the responsibilities set forth in the Interlocal Agreement with the County.

To ensure full compliance with state mandated procedures regarding acquisition and disposition of properties the City/Agency shall be governed by the following procedures and parameters delineated in Chapter 163, Part III, *Florida Statutes*. In addition, the CRA shall have prepared a detailed Land Acquisition and Disposition Protocols that will be adopted by the Board. These protocols shall meet and/or exceed the requirements presented in the CRA Plan.

163.370 Powers; counties and municipalities; community redevelopment agencies

(1) *Counties and municipalities may not exercise the power of eminent domain for the purpose of preventing or eliminating a slum area or blighted area as defined in this part; however, counties and municipalities may acquire property by eminent domain within a community redevelopment area, subject to the limitations set forth in ss. 73.013 and 73.014 or other general law.*

(2) *Every county and municipality shall have all the powers necessary or convenient to carry out and effectuate the purposes and provisions of this part, including the following powers in addition to others herein granted:*

(a) *To make and execute contracts and other instruments necessary or convenient to the exercise of its powers under this part.*

(b) *To disseminate slum clearance and community redevelopment information.*

(c) *To undertake and carry out community redevelopment and related activities within the community redevelopment area, which may include:*

1. *Acquisition of property within a slum area or a blighted area by purchase, lease, option, gift, grant, bequest, devise, or other voluntary method of acquisition.*

2. *Demolition and removal of buildings and improvements.*

3. *Installation, construction, or reconstruction of streets, utilities, parks, playgrounds, public areas of major hotels that are constructed in support of convention centers, including meeting rooms, banquet facilities, parking garages, lobbies, and passageways, and other improvements necessary for carrying out in the community redevelopment area the community redevelopment objectives of this part in accordance with the community redevelopment plan.*

4. *Disposition of any property acquired in the community redevelopment area at its fair value as provided in s. 163.380 for uses in accordance with the community redevelopment plan.*

5. *Carrying out plans for a program of voluntary or compulsory repair and rehabilitation of buildings or other improvements in accordance with the community redevelopment plan.*

6. *Acquisition by purchase, lease, option, gift, grant, bequest, devise, or other voluntary method of acquisition of real property in the community redevelopment area which, under the community redevelopment plan, is to be repaired or rehabilitated for dwelling use or related facilities, repair or rehabilitation of the structures for guidance purposes, and resale of the property.*

7. *Acquisition by purchase, lease, option, gift, grant, bequest, devise, or other voluntary method of acquisition of any other real property in the community redevelopment area when necessary to eliminate unhealthful, unsanitary, or unsafe conditions; lessen density; eliminate obsolete or other uses detrimental to the public welfare; or otherwise to remove or prevent the spread of blight or deterioration or to provide land for needed public facilities.*

8. *Acquisition, without regard to any requirement that the area be a slum or blighted area, of air rights in an area consisting principally of land in highways, railway or subway tracks, bridge or tunnel entrances, or other similar facilities which have a blighting influence on the surrounding area and over which air rights sites are to be developed for the elimination of such blighting influences and for the provision of housing (and related facilities and uses) designed specifically for, and limited to, families and individuals of low or moderate income.*

9. *Acquisition by purchase, lease, option, gift, grant, bequest, devise, or other voluntary method of acquisition of property in unincorporated enclaves surrounded by the boundaries of a community redevelopment area when it is determined necessary by the agency to accomplish the community redevelopment plan.*

10. *Construction of foundations and platforms necessary for the provision of air rights sites of housing (and related facilities and uses) designed specifically for, and limited to, families and individuals of low or moderate income.*

(d) To provide, or to arrange or contract for, the furnishing or repair by any person or agency, public or private, of services, privileges, works, streets, roads, public utilities, or other facilities for or in connection with a community redevelopment; to install, construct, and reconstruct streets, utilities, parks, playgrounds, and other public improvements; and to agree to any conditions that it deems reasonable and appropriate which are attached to federal financial assistance and imposed pursuant to federal law relating to the determination of prevailing salaries or wages or compliance with labor standards, in the undertaking or carrying out of a community redevelopment and related activities, and to include in any contract let in connection with such

redevelopment and related activities provisions to fulfill such of the conditions as it deems reasonable and appropriate.

(e) Within the community redevelopment area:

- 1. To enter into any building or property in any community redevelopment area in order to make inspections, surveys, appraisals, soundings, or test borings and to obtain an order for this purpose from a court of competent jurisdiction in the event entry is denied or resisted.*
- 2. To acquire by purchase, lease, option, gift, grant, bequest, devise, or other voluntary method of acquisition any personal or real property, together with any improvements thereon.*
- 3. To hold, improve, clear, or prepare for redevelopment any such property.*
- 4. To mortgage, pledge, hypothecate, or otherwise encumber or dispose of any real property.*
- 5. To insure or provide for the insurance of any real or personal property or operations of the county or municipality against any risks or hazards, including the power to pay premiums on any such insurance.*
- 6. To enter into any contracts necessary to effectuate the purposes of this part.*
- 7. To solicit requests for proposals for redevelopment of parcels of real property contemplated by a community redevelopment plan to be acquired for redevelopment purposes by a community redevelopment agency and, as a result of such requests for proposals, to advertise for the disposition of such real property to private persons pursuant to s. 163.380 prior to acquisition of such real property by the community redevelopment agency.*

(f) To invest any community redevelopment funds held in reserves or sinking funds or any such funds not required for immediate disbursement in property or securities in which savings banks may legally invest funds subject to their control and to redeem such bonds as have been issued pursuant to s. 163.385 at the redemption price established therein or to purchase such bonds at less than redemption price, all such bonds so redeemed or purchased to be canceled.

(g) To borrow money and to apply for and accept advances, loans, grants, contributions, and any other form of financial assistance from the Federal Government or the state, county, or other public body or from any sources, public or private, for the purposes of this part and to give such security as may be required and to enter into and carry out contracts or agreements in connection therewith; and to include in any contract for financial assistance with the Federal Government for or with respect to community redevelopment and related activities such conditions imposed pursuant to federal laws as the county or

municipality deems reasonable and appropriate which are not inconsistent with the purposes of this part.

(h) To make or have made all surveys and plans necessary to the carrying out of the purposes of this part; to contract with any person, public or private, in making and carrying out such plans; and to adopt or approve, modify, and amend such plans, which plans may include, but are not limited to:

1. Plans for carrying out a program of voluntary or compulsory repair and rehabilitation of buildings and improvements.

2. Plans for the enforcement of state and local laws, codes, and regulations relating to the use of land and the use and occupancy of buildings and improvements and to the compulsory repair, rehabilitation, demolition, or removal of buildings and improvements.

3. Appraisals, title searches, surveys, studies, and other plans and work necessary to prepare for the undertaking of community redevelopment and related activities.

(i) To develop, test, and report methods and techniques, and carry out demonstrations and other activities, for the prevention and the elimination of slums and urban blight and developing and demonstrating new or improved means of providing housing for families and persons of low income.

(j) To apply for, accept, and utilize grants of funds from the Federal Government for such purposes.

(k) To prepare plans for and assist in the relocation of persons (including individuals, families, business concerns, nonprofit organizations, and others) displaced from a community redevelopment area and to make relocation payments to or with respect to such persons for moving expenses and losses of property for which reimbursement or compensation is not otherwise made, including the making of such payments financed by the Federal Government.

(l) To appropriate such funds and make such expenditures as are necessary to carry out the purposes of this part; to zone or rezone any part of the county or municipality or make exceptions from building regulations; and to enter into agreements with a housing authority, which agreements may extend over any period, notwithstanding any provision or rule of law to the contrary, respecting action to be taken by such county or municipality pursuant to any of the powers granted by this part.

(m) To close, vacate, plan, or replan streets, roads, sidewalks, ways, or other places and to plan or replan any part of the county or municipality.

(n) To organize, coordinate, and direct the administration of the provisions of this part, as they may apply to such county or municipality,

In order that the objective of remedying slum and blighted areas and preventing the causes thereof within such county or municipality may be most effectively promoted and achieved and to establish such new office or offices of the county or municipality or to reorganize existing offices in order to carry out such purpose most effectively.

(o) To develop and implement community policing innovations.

(3) The following projects may not be paid for or financed by increment revenues:

(a) Construction or expansion of administrative buildings for public bodies or police and fire buildings, unless each taxing authority agrees to such method of financing for the construction or expansion, or unless the construction or expansion is contemplated as part of a community policing innovation.

(b) Installation, construction, reconstruction, repair, or alteration of any publicly owned capital improvements or projects if such projects or improvements were scheduled to be installed, constructed, reconstructed, repaired, or altered within 3 years of the approval of the community redevelopment plan by the governing body pursuant to a previously approved public capital improvement or project schedule or plan of the governing body which approved the community redevelopment plan unless and until such projects or improvements have been removed from such schedule or plan of the governing body and 3 years have elapsed since such removal or such projects or improvements were identified in such schedule or plan to be funded, in whole or in part, with funds on deposit within the community redevelopment trust fund.

(c) General government operating expenses unrelated to the planning and carrying out of a community redevelopment plan.

(4) With the approval of the governing body, a community redevelopment agency may:

(a) Prior to approval of a community redevelopment plan or approval of any modifications of the plan, acquire real property in a community redevelopment area by purchase, lease, option, gift, grant, bequest, devise, or other voluntary method of acquisition; demolish and remove any structures on the property; and pay all costs related to the acquisition, demolition, or removal, including any administrative or relocation expenses.

(b) Assume the responsibility to bear any loss that may arise as the result of the exercise of authority under this subsection, in the event that the real property is not made part of the community redevelopment area.

Areawide Programs and Tools

This section provides the tools for the implementation of redevelopment activities. The programs outlined in this section may be utilized as needed over the life of the Agency. Specific details and criteria will be established and approved by the Agency Board in accordance with the procedure delineated in Safeguards to Ensure Redevelopment Activities Follow the CRA Plan.

The programs included within the CRA Plan may be designed either in a site-specific manner or in a comprehensive manner such that the programs exist as "tools in a toolbox" whereby any individual program may apply to a number of different properties or initiatives within the Redevelopment Area. The Agency has determined that an appropriate strategy to achieve the Agency's goals is to utilize the "toolbox" approach. This policy decision provides the Agency with the greatest ability to serve the redevelopment needs of the community as they evolve over the remaining life of the Agency.

Economic Development and Job Creation Programs

163.345 Encouragement of private enterprise.

(1) Any county or municipality, to the greatest extent it determines to be feasible in carrying out the provisions of this part, shall afford maximum opportunity, consistent with the sound needs of the county or municipality as a whole, to the rehabilitation or redevelopment of the community redevelopment area by private enterprise. Any county or municipality shall give consideration to this objective in exercising its powers under this part, including the formulation of a workable program; the approval of community redevelopment plans, communitywide plans or programs for community redevelopment, and general neighborhood redevelopment plans (consistent with the general plan of the county or municipality); the development and implementation of community policing innovations; the exercise of its zoning powers; the enforcement of other laws, codes, and regulations relating to the use of land and the use and occupancy of buildings and improvements; the development of affordable housing; the disposition of any property acquired, subject to the limitations of s.73.013; and the provision of necessary public improvements.

(2) In giving consideration to the objectives outlined in subsection (1), the county or municipality shall consider making available the incentives provided under the Florida Enterprise Zone Act and chapter 420.

Direct Financial Incentives to Generate New Private Development

There is often an economic "gap" between the total cost of development of a project and the market value of the completed project, due largely to the high cost of site acquisition. There is a need for a reduction in cost to make projects financially viable for private developers. With regard to residential uses, there is sometimes a need to stimulate homeownership and offer new housing options in a range of prices in accordance with sound inclusionary housing strategies. The Agency will be empowered to financially subsidize commercial, residential, and mixed-use private

development projects, including but not limited to direct grants and the sale of real estate owned by the Agency at a discounted price. The Agency will prepare and adopt guidelines for determining eligibility and the amount of the incentive payment or discount before such initiatives are implemented. The guidelines will include the use of up to 75% of anticipated new tax increment to help fill such gaps, and the program will be reviewed every two years to determine if adjustments are needed.

Direct Financial Incentives to Stimulate Property Improvements

Owners of commercial or residential properties often cannot justify the cost of renovations because rents will not increase enough to provide an acceptable return on investment. The Agency will be empowered to financially subsidize the cost of renovations through loans or matching grants to property owners, including commercial properties, rental apartment properties, and condominium associations. Property improvements such as conversion of rental units to condominiums shall also be eligible. The Agency will prepare and adopt guidelines as to the type of eligible costs and the funding ceiling of grants or loans before such incentives are implemented.

Financial Incentives for New Businesses

Attracting new businesses will be critical to the success of the redevelopment and revitalization of the commercial portions of the Redevelopment Area. The ability to offer financial incentives increases the potential for success in attracting the numbers and types of businesses needed and desired to create a sustainable business community.

The Agency is empowered to use Tax Increment Finance ("TIF") fund monies to pay incentives to new businesses that locate in the Redevelopment Area. The Agency will prepare and adopt guidelines as to the type of businesses that will be eligible and the amount of the financial incentive, before such incentives are implemented.

Rehabilitation of Vacant Commercial Buildings

Key underutilized vacant commercial buildings may be identified within the Redevelopment Area. The Agency may pursue the purchase of these buildings, work to establish joint-venture opportunities, or assist in the attraction of business occupants to ensure these structures perform to their economic potential.

Market Research

The Agency may provide funding and guidance to create a useful and locally tailored economic analysis to identify demand for various real estate offerings including: hotels, office, residential, entertainment, and retail, including the appropriate retail mix for any portion of the Redevelopment Area. The goal of this research would be to provide information for business owners and developers indicating what profitable business opportunities exist, given the market area, socio-economic character, and dynamics of the market.

Advertisement and Promotions

There will be an ongoing need to ensure awareness of investment, development, business, and residential opportunities within the Redevelopment Area. In addition, there will also be a need to provide promotional support for area businesses and to create an identity for various parts of the Redevelopment Area (place brands).

Towards this end, the Agency may assist in the funding for the creation of marketing and promotional programs aimed at increasing business volume and residential demand in the area. Appropriate media venues shall include but not be limited to television commercials, radio commercials, web sites and social media, outdoor billboards and banners, special events, and print media (newspaper, magazine, specialty publications, marketing collateral). The Agency may also consider assisting in the funding of special events. The Agency is empowered to pay for promotional efforts, including but not limited to, staff, consultants, materials production costs, distribution costs, special purpose equipment and systems, and events.

Business and Redeveloper Attraction

The Agency may take steps to actively attract quality businesses, investors and redevelopers to the Redevelopment Area in cooperation with appropriate entities such as the local Chamber of Commerce. In carrying out its functions, the Chamber will use its resources to ensure that economic development events which take place within the CRA are marketed, and information is provided through the resources of the Chamber to ensure maximum exposure of CRA economic development activities in an effort to attract more business and encourage investment and job creation.

Business Incentive Loans

The Agency may create a loan pool and program for qualified businesses in the Redevelopment Area to assist with the start-up costs and capital needs of new and expanding businesses in order to reconstruct a better Redevelopment Area. The Agency will prepare and adopt guidelines as to the type of eligible costs and the funding ceiling of grants or loans before such incentives are implemented.

Coalition of Financial Institutions

The Agency may recruit interested local financial institutions to participate in any and all redevelopment programs, ranging from business loans and residential rehabilitation to subsidized mortgages and loan guarantees. This may include assistance to create shared pools of loan funds targeted for the Redevelopment Area.

Beautification and Appearance Improvement

Clean-Up Program

The appearance of the Redevelopment Area sends a direct message to property owners and potential investors regarding the community's commitment towards its success. Working with community residents and property owners, the Agency may provide funding for a program to

remove trash and graffiti, clean streets and sidewalks, and otherwise clean up key parts of the Redevelopment Area.

Signage/Entry Features

The visual appearance of Redevelopment Area gateway areas needs to be enhanced. Further, there is a need to establish a brand identity for this important core area of the community.

The Agency is empowered to pay for aesthetic and identity enhancements, including but not limited to, signage, entry features, public art, banners, lighting, and landscaping.

Landscaping/Streetscaping Programs

The Agency may design and install landscape and streetscape improvements, including but not limited to landscape materials, lighting, wayfinding signage, benches and trash receptacles in areas identified by the Board.

Paint- Up/Fix-Up

The Agency may create and fund a simplified rehabilitation program designed to improve the appearance of the Redevelopment Area through extensive exterior repainting of public and private structures in the Redevelopment Area. The Agency will prepare and adopt guidelines as to the type of eligible costs and the funding ceiling of grants or loans before such incentives are implemented.

Pedestrian Amenities

The Agency may provide public pedestrian amenities including as an incentive to private development initiatives. These amenities may include, but are not limited to, park benches, shade trees, bicycle racks, gazebos, lighting, signage, crosswalks, bridges, walk signals, and trash containers.

Signage Program

The Agency may encourage business owners to develop attractive signage by awarding partial funding for such signs. All signage must conform to the City's standard sign ordinances. The Agency will prepare and adopt guidelines as to the type of eligible costs and the funding ceiling of grants or loans before such incentives are implemented.

Art in Public Places

The Agency may appropriate or secure funds for the purchase and installation of art in public places within the Redevelopment Area. Emphasis shall be placed on utilizing local artists to create local themes.

Continuing Maintenance Responsibilities

All projects that the CRA undertakes or contributes to must receive a continuing commitment regarding maintenance and upkeep. The Agency shall be committed to protecting the return on investment for all projects funded by Tax Increment Finance revenues. The Agency may contract

with the City of North Miami Beach or private entities to assure proper maintenance of public improvements.

Specific Projects and Programs to Advance

While this plan anticipates an evolving array of project and program investments depending on community needs and private development concepts within the framework and policies of this plan, the following projects and programs comprise an initial list of anticipated investments:

West Dixie Highway North – Road/Right of Way and Bridge Improvements:

In keeping with the Comprehensive Plan, zoning regulations, and in partnership with Miami-Dade County, this project will include capacity improvements for vehicles, pedestrians, and bicycles as well as walkability amenities like improved lighting, a signature bridge, and drainage and sewer improvements, among other things. Please see Appendix "D."

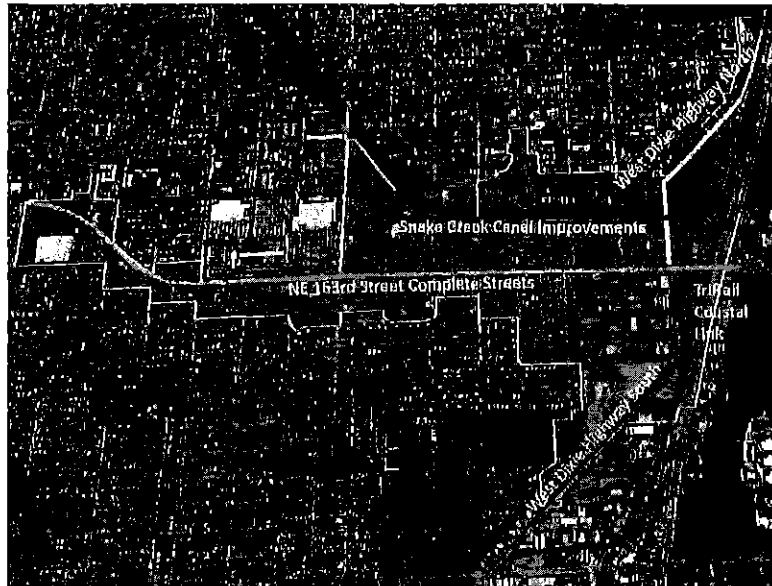

West Dixie Highway South – In keeping with the Comprehensive Plan, zoning regulations, and in partnership with FDOT and Miami-Dade County, this project will include capacity improvements for vehicles, pedestrians, and bicycles as well as walkability amenities like improved lighting, and drainage and sewer improvements, among other things.

Wayfinding Signage – To enhance the retail/entertainment visitor experience, support district branding initiatives, and expand business growth and attraction, additional elements of a comprehensive wayfinding system will be designed and installed. Initially, these will be focused on the 163rd Street and West Dixie Highway corridors along with the Town Center, Spanish Monastery, and commuter rail station transit oriented development as key destinations.

Drainage Improvements and sewer connections – A limited investment will be made to assist with sewer connections and drainage improvements related to new private investments. These projects will focus on Hanford Boulevard and West Dixie Highway.

Snake Creek Parks/Open Space – To attract additional private investment along Hanford Boulevard and parts of West Dixie Highway, improvements to the recreational spaces along

portions of Snake Creek Canal will be made, often in conjunction with private developer investments.

Parking Improvements – To attract additional businesses, business expansions, and development investments to Hanford Boulevard and West Dixie Highway, new or expanded parking garages or lots will be developed, most likely in partnership with major private projects, but designed and managed to serve the larger districts.

Business Attraction Programs – A variety of marketing initiatives will be used to help attract new customers and businesses to the district. This will include special events, printed and electronic promotional materials, social media campaigns, and other similar investments.

Transit-Oriented Development (“TOD”) Projects – The planned Coastal Link rail station will create a unique opportunity for mixed use projects nearby, and a variety of investments will be made to assist such projects in order to help reduce traffic congestion and attract private investments.

Public-Private Partnerships (“P3s”) – As noted throughout this plan, P3s are authorized and will be used regularly to help attract new developments, attract new businesses, and expand existing businesses. Such partnerships may involve transit, parks, and parking facilities.

Façade Improvement Programs – To improve the image and place-brand of the district, exterior façade grants and loans will be made for commercial and large multi-family residential properties in key locations. Where appropriate and authorized by the Board, these programs will also help to correct interior code violations in conjunction with comprehensive exterior improvements.

Complete Streets Improvements for 163rd Street – Given the crucial role that 163rd Street plays in the image and brand of the district and City, a variety of roadway, pedestrian, bicycle, landscaping and related improvements will be made to gateway areas of the street. This will be accomplished in partnership with Miami-Dade County and FDOT.

Infrastructure Improvement Programs

Working with appropriate City departments, the Agency may consider allocating funds to remedy infrastructure deficiencies and projected needs, including but not limited to utilities, roadways, sidewalks, bridges, and storm water management. All Infrastructure projects funded by the Agency shall be directly tied to increasing the Redevelopment Area potential to generate a higher return of tax increment funds and increase the likelihood of private investment. This program is not designed to replace the City's efforts to secure Community Development Block Grants and other similar funds but rather to augment them.

Street, Sidewalk, and Alley Improvements

There are streets, sidewalks, and alleys in the Redevelopment Area that are in need of repair or rebuilding. The Agency is empowered to pay the cost of repairing and rebuilding streets, sidewalks, intersections, and alleys in the Redevelopment Area. Improvements also may include, but not be limited to, sidewalks, landscaping, street and pedestrian lights, street furniture and signs.

Stormwater Drainage Improvements

There are streets, alleys and sidewalks in the Redevelopment Area that flood during rainstorms. In some cases, the ponding remains for days after the storm. Further, many individual properties in the anticipated rebuilt urban environment will not be able to retain stormwater on-site, which will seriously limit the potential for new development.

To maximize its ability to address water quality issues, the Agency may avail itself of the authority to create a storm water utility mechanism and funding source. If initiated, this effort shall be properly coordinated with appropriate government entities. The use of a storm water utility will likely minimize the land area necessary to advance water quality improvement, will further protect the Maule Lake, Oleta River, Snake Creek Canal, and Biscayne Bay, and further provide a dedicated revenue source to support this effort. The Agency will be empowered to pay for stormwater drainage solutions, including but not limited to, subsidizing stormwater management costs incurred on privately owned property, creation of a stormwater utility for the CRA, and development of one or more master drainage systems.

Improvements to the water quality of Maule Lake, the Oleta River, Snake Creek Canal, and Biscayne Bay should be a consideration of undertaking any program or strategy for improving drainage infrastructure within the CRA should be a consideration of undertaking any program or strategy for improving drainage infrastructure.

Sanitary Sewer Installations

There are commercial properties in the Redevelopment Area that do not have connections to the sanitary sewer system. This limits the potential for new development. The Agency may pay the cost to extend sanitary sewer lines. The Agency will prepare and adopt guidelines as to the type of eligible costs and the funding ceiling of grants or loans before such incentives are implemented.

Parking Facilities

As redevelopment occurs and encourages a higher and more efficient intensity of development, there will be a need for public and publicly accessible private parking lots or structures to supplement the private parking. The Agency may pay for developing such parking facilities, including both surface lots and structured parking. The Agency may also participate in public/private joint ventures for the provision of public and publicly accessible private parking. The Agency may either purchase or lease property or air rights for parking facilities.

Underground Utilities

The Agency may encourage and advocate future development projects to construct underground utilities by offering assistance and incentives, which may include financing, density bonuses, or other means to ensure that development order approvals consider this as a condition of approval. Further, the Agency may undertake an advocacy role on behalf of project proposals which include the voluntary placement of utilities underground.

Environmental Clean-up Programs

Brownfields

Redevelopment of contaminated properties requires additional expense due to remediation costs, which limits redevelopment opportunities. The Agency may be empowered to provide grants, loans, or other forms of financial assistance to developers and property owners to cover costs associated with redevelopment of contaminated properties.

Environmental Clean-Up

The Agency may establish a fund, which may be used to assist in the clean-up of environmentally contaminated sites. The Agency will activate this program in the event that a viable and desirable redevelopment project necessitates the reuse of a contaminated site. The degree of the Agency's financial participation will be determined by the Agency on a case-by-case basis contingent upon the redevelopment value of the project. The Agency may also seek grants for the purpose of assessment and remediation. These grant funds may be used by the Agency directly or provided in the form of a grant or loan to a property owner.

Redevelopment Advocacy

Redevelopment Advocacy Activities

The Agency shall actively advocate for actions by other public and private bodies, which are to the benefit of area residents and businesses.

Provide Matching Funds for Grants

As provided by Chapter 163, Part 163, *Florida Statutes*, the Agency may apply for and receive grants. Most grant programs require some level of matching funding from the recipient. The Agency may use trust fund monies to provide matching funds for grants when the proceeds of the grant will be used for undertakings that are specified in the CRA Plan and are within the Redevelopment Area.

Code Enforcement Enhancement

The Agency may fund increased code enforcement services within the Redevelopment Area. The goal of this program is to increase the marketability and aesthetics of the properties in the Redevelopment Area.

Adequate code enforcement is required to protect property values, commercial activity levels and the quality of life of the residents within the Redevelopment Area and also for reducing slum and blighted areas. Code enforcement also is important to attracting new investment, new development, new businesses, and new residents. The Agency will be empowered to pay for one or more code enforcement officers who shall operate solely within the Redevelopment Area. In addition, the Agency may pay for support vehicles and equipment.

Some of the major areas in which enhanced Code Enforcement can be beneficial to the CRA are:

- Graffiti removal
- Right-of-way landscape maintenance
- Window coverage on businesses
- Parking lot usage and access

The Agency also may reimburse the City for additional code officers that operate only part time in the Redevelopment Area.

Community Policing Innovations

Adequate law enforcement is required to protect property values, commercial activity levels and the quality of life of the residents within the Redevelopment Area. Law enforcement and other innovative efforts to improve real and perceived safety are also important to attract new investment, new development, new businesses and new residents. The Agency shall have the authority to pay for the cost of utilizing innovative community policing strategies designed to prevent and reduce crime and enhance safety perceptions within the Redevelopment Area.

Housing Policies and Programs

Attracting new residents and homeowners to the Redevelopment Area helps to support retail businesses, stabilize neighborhoods, improve property values, and achieve the mixed use vision of the plan for key districts. Carefully designed housing will also help improve both real and perceived safety for the Redevelopment Area.

The goal is to achieve a “Healthy Mix” of affordable, workforce, market rate, luxury, and mixed-income housing for the district and the City.

The Agency may work with the private sector to identify and create public-private partnerships for commercial, residential, industrial or mixed use projects to realize redevelopment goals and increase the tax base. This may include providing incentives to developers in the form of loans, grants, or discounted land to create such carefully designed and placed new housing in ways that help support the overall vision. The Agency will prepare and adopt guidelines as to the type of eligible costs and the funding ceiling of grants or loans before such incentives are implemented.

The Agency may invest in roadways, parking, sidewalks, streetscape, parks, and similar public improvements to support a healthy mix of housing in ways that realize redevelopment goals and increase the tax base.

The Agency may invest in improvements to existing multi-family housing projects in key locations to enhance quality of life, image and brand, property values, and safety. Such investments may include exterior improvements as well as improvements to remedy code violations.

Safeguards to Ensure Redevelopment Activities Follow the Plan

Safeguards to Ensure Financial Accountability

The Agency shall be fully subject to the Florida Sunshine Law and will meet as necessary to carry out the business of the Agency.

The Agency shall publicly adopt by-laws to govern its activities and to ratify its administrative policies.

The Agency shall file an annual report with the State of Florida Special District Program and the Miami-Dade County, and the North Miami Beach City Clerk's Office. This report shall contain a programmatic overview of the activities of the Agency as allowed by the CRA Plan.

The Agency shall provide adequate safeguards to ensure that all leases, deeds, contracts, agreements and declarations of restrictions relative to any real property conveyed shall contain restrictions, covenants, running with the land and its uses, or other such provisions necessary to carry out the goals and objectives of the Plan and Chapter 163, Part III, *Florida Statutes* and other governing statutes.

The Agency shall maintain adequate records to provide for an annual audit, which shall be conducted by an independent knowledgeable auditor selected by the City Council. The findings of the audit shall be presented at a public meeting of the Agency Board and such findings shall be forwarded to the State Auditor General's Office by March 31st of each year for the preceding fiscal year, which shall run from October 1st through September 30th.

Section 163.356(3) (c) The governing body of the county or municipality shall designate a chair and vice chair from among the commissioners. An agency may employ an executive director, technical experts, and such other agents and employees, permanent and temporary, as it requires, and determine their qualifications, duties, and compensation. For such legal service as it requires, an agency may employ or retain its own counsel and legal staff. An agency authorized to transact business and exercise powers under this part shall file with the governing body, on or before March 31 of each year, a report of its activities for the preceding fiscal year, which report shall include a complete financial statement setting forth its assets, liabilities, income, and operating expenses as of the end of such fiscal year. At the time of filing the report, the agency shall publish in a newspaper of general circulation in the community a notice to the effect that such report has been filed with the county or municipality and that the report is available for inspection during business hours in the office of the clerk of the city or county commission and in the office of the agency.

The annual Audit Report shall be accompanied by the Agency's Annual Report and shall be provided to the City Clerk's Office for public review and availability. Legal notice in a newspaper of general circulation shall be provided to inform the public of the availability for review of the Annual Audit and Annual Report. The Agency shall file all reports necessary to comply with the "Special Districts" requirements of the State of Florida.

All Agency tax increment financing funds shall be held in a Redevelopment Trust Fund accounted for separately from other funds as required by state law.

Safeguards to Ensure Proper Implementation and Project/Program Accountability

1. Objectives for each Agency activity shall be established upon its administrative design and funding approval by the Board.
2. The Agency shall hold an annual informational public workshop to:
 - a) Report on the status and progress of programs and projects;
 - b) Gather input from property owners, citizens and interested parties regarding redevelopment activities; and
 - c) Discuss strategies relating to local redevelopment issues.

Safeguards Through the Retention of Powers by the City and the County

The Interlocal Agreement contains safeguards through the retention of powers by the City and the County. Please see Appendix "A."

Community Redevelopment Agency Goals, Objectives and Policies

Encouragement of Private Enterprise

At the time this 2015 Plan Amendment is being prepared, the national economy is in a period of moderate economic growth. The South Florida regional economy has seen healthy growth and extensive real estate development over the last two years, and investor interest in the Redevelopment Area is increasing.

To take advantage of this renewed interest, the Board may consider advancing its role as an economic catalyst by investing in and partnering with the private sector.

While this 2015 Plan Amendment allows for the Agency to allocate its resources and revenue towards the public sector infrastructure, the leadership of the City's redevelopment effort may also consider utilizing its powers, strategies, and innovative tools to strongly encourage the economic health of private enterprise.

Section 163.345 Encouragement of private enterprise.

(1) Any county or municipality, to the greatest extent it determines to be feasible in carrying out the provisions of this part, shall afford maximum opportunity, consistent with the sound needs of the county or municipality as a whole, to the rehabilitation or redevelopment of the community redevelopment area by private enterprise. Any county or municipality shall give consideration to this objective in exercising its powers under this part, including the formulation of a workable program; the approval of community redevelopment plans, communitywide plans or programs for community redevelopment, and general neighborhood redevelopment plans (consistent with the general plan of the county or municipality); the development and implementation of community policing innovations; the exercise of its zoning powers; the enforcement of other laws, codes, and regulations relating to the use of land and the use and occupancy of buildings and improvements; the development of affordable housing; the disposition of any property acquired, subject to the limitations of s. 73.013; and the provision of necessary public improvements.

(2) In giving consideration to the objectives outlined in subsection (1), the county or municipality shall consider making available the incentives provided under the Florida Enterprise Zone Act and chapter 420.

Compliance with the City of North Miami Beach Comprehensive Plan and Land Development Regulations

As required by Section 163.360, Part III, *Florida Statutes* the CRA Plan shall: Conform to the comprehensive plan for the county or municipality as prepared by the local planning agency under the Local Government Comprehensive Planning and Land Development Regulation Act.

Goals, Objectives and Policies

The following objectives and policies are taken from the current City of North Miami Beach Comprehensive Plan. By their inclusion in the 2015 Plan Amendment the Agency is adopting and operating in support of the City's Comprehensive Plan. This CRA Plan shall be subordinate to any and all future amendments and modifications to the City's Comprehensive Plan.

This 2015 Plan Amendment was found consistent with the City's Comprehensive Plan at the City's Planning and Zoning Board meeting held on January 11th, 2016 by a vote of 7 to 0.

Future Land Use Element

Goal 1

Encourage redevelopment and development to enhance the economic base of the City, improve the aesthetic quality of the commercial corridors and existing neighborhoods, and provide a range of housing and employment opportunities to accommodate, serve and employ the projected population, while protecting established single family neighborhoods.

Policy 1.1.8

The City shall require proposed amendments to the Future Land Use Map provide data and analysis demonstrating adequate water supply and facilities are available.

Objective 1.2

Detail a redevelopment strategy for potential redevelopment area, including those cited in this plan (see Map 1.16, Volume Four). Redevelopment could include Future Land Use Map designation changes as necessary to facilitate enhancement of these areas. (e.g. additional recreation and open space land). Measure: This objective shall be measured by progress in implementing its policies.

Policy 1.2.3

The City shall continue to seek federal, state, and local funds for redeveloping the S.R. 826 (NW 163 and 167 Street) Corridor and ensure the redevelopment of said corridor encourages a strong regional commercial atmosphere.

Policy 1.2.5

Amend the Future Land Use Map (See Map 1.22, Volume Four) as necessary to support the intent of the Goal of the Future Land Use Element. Future Land Use Map amendments allowing additional residential units in the City through increased density or conversion of non-residentially designated land to a residential designation shall be allowed only if it can be demonstrated that such amendments will not negatively affect the City's transportation facilities, infrastructure, schools, recreation opportunities, and overall quality of life.

Policy 1.2.6

The City's redevelopment strategy shall address the full range of redevelopment impacts, including the displacement of existing populations, the loss of historic structures and neighborhood character, and the overburdening of existing infrastructure.

Policy 1.2.7

The City shall encourage redevelopment in proximity to transit stops and hubs through the implementation of activities and programs (i.e. density bonuses, park and ride, establishing a land use category for transit hub areas...) that promote redevelopment in targeted areas.

Policy 1.2.8

The City shall encourage development and redevelopment of appropriate scale and type in areas adjacent to established residential neighborhoods. Appropriate scale and type shall be determined by reviewing the compatibility of proposed development and redevelopment with the adjacent residential uses.

Policy 1.2.9

By 2015, the City shall evaluate the feasibility of developing a waterfront promenade to enhance the City Center and Snake Creek Canal in accordance with the recommendations of the 2007 Urban Design Plan.

Policy 1.2.11

All redevelopment shall be sensitive to the community character, and should seek to promote transit and pedestrian friendliness through features such as: interconnected sidewalks; transit shelters; an interesting pedestrian environment, and; shade from shade trees, awnings, or canopies.

Policy 1.2.12

The City should consider developing and adopting form-based land development regulations that specify acceptable transitions within redevelopment areas.

Policy 1.2.13

In order to evaluate applications for Future Land Use Map changes in redevelopment areas, the City should require applicants to provide market studies that reflect real estate market demands.

Policy 1.2.14

The Community Redevelopment Agency should seek to strengthen businesses in the redevelopment areas.

Policy 1.2.15

The City will require development in the redevelopment areas to promote mixed-use development, defined as design-unified, vertically and or horizontally integrated, pedestrian friendly development. Mixed use areas should provide for multi-modal transportation

connectivity to other areas, encourage mass transit, reduce the need for automobile travel, provide incentives for quality development, and give definition to the urban form.

Policy 1.2.17

The City should consider changes to the Zoning and Land Development Code and Future Land Use categories to permit mixed-use development in proximity to the FEC railway, major transit corridors and within the City's redevelopment areas.

Policy 1.2.18

The City should encourage the use of Crime Prevention through Environmental Design (CPTED) standards in the redevelopment of the City and formalize these standards within the Zoning and Land Development Code, enhancing the safety of the City by limiting design factors which abet crime.

Policy 1.2.19

East of US1, the City's intent is to increase the amount of open space in accordance with the Open Space Regulating Plans adopted for each mixed-use district east of US 1 and with the Parks Master Plan, when adopted.

Policy 1.3.3

The City's street tree planting program shall concentrate on increasing landscape buffers between residential and commercial.

Objective 1.5

The City shall coordinate with Miami-Dade County, the South Florida Regional Planning Council and the State of Florida in evaluating the impacts of development and redevelopment on hurricane evacuation clearance times, structural integrity, and disaster-preparedness needs. Measures: Demonstrable examples of coordination through the development review process.

Policy 1.5.1

Unless extremely compelling reasons are advanced, deny any developer plan amendments and rezoning requests that would increase population densities in the Eastern Shores area in order to avoid further burdens on the hurricane evacuation process. Vacant parcels should be developed at densities and intensities consistent with the Future Land Use Map.

Policy 1.5.2

The City will coordinate with the South Florida Regional Planning Council (SFRPC) in order to evaluate the effect that development and redevelopment in accordance with the densities and intensities allowed under Policy 1.8.1, as adopted in September, 2006, may have on hurricane evacuation clearance times for the coastal zone area. The City will commit to working with the appropriate parties to mitigate the impact of Policy 1.8.1, to the extent that development or redevelopment in accordance with Policy 1.8.1 would increase the allowable clearance times for various hurricane intensities.

Policy 1.5.5

The City shall evaluate all proposed large-scale amendments to the Comprehensive Plan and/or zoning applications to determine their impact on hurricane evacuation routes and times, and effect on currently available off-site shelter capacities. Roadway improvements and shelter improvements shall be required to mitigate negative impacts, if deemed necessary, and phased with new residential development.

Objective 1.6

Facilitate mixed-use and planned unit development projects that are of appropriate intensity, density, land use mix, and urban design to foster walkable neighborhoods, great public spaces, and increase the viability of pedestrian, bicycle and public modes of transportation, and reduce dependency on the automobile. Measures: Number of successful developments or redevelopments implemented in accordance with revised Land Development Regulations for Mixed-Use (objective – at least one by January 1, 2015). "Successful means general satisfaction of parties involved with approval, including property owner, City officials, and the public.

Policy 1.6.1

Amend the Land Development Regulations in accordance with the Mixed-Use Future Land Use Designations and create unique zoning regulations for each mixed-use district for the purpose of encouraging and achieving the vision established for each mixed-use district.

Policy 1.6.2

Direct future residential, office and retail growth compatible with an urban downtown environment to the Fulford City Center (MU/TC, Mixed-Use Town Center) and Community Redevelopment Area.

Policy 1.6.3

The City shall facilitate and encourage development of the City's designated Mixed-Use Districts. The City shall explore incentives for maximum land utilization, including proportions of mixed-use, which may include the following, and shall amend the land development regulations as necessary to implement these incentives:

- a. reduction of required off-street parking requirements and/or shared parking agreements
- b. air rights easements over alleys or other rights-of-way
- c. reduction of road impact fees (reverse impact fee structure, since higher density and intensity supports transit usage)
- d. revision of impact fees to instead fund transit, bicycle and pedestrian infrastructure.
- e. Financial assistance and/or parcel assemblage coordination assistance from the Community Redevelopment Agency, when applicable
- f. Marketing assistance from the Community Redevelopment Agency, when applicable
- g. Location of circulator bus stop as part of a local transit network
- h. Initial property tax rebate program, when applicable

I. Public-Private Partnerships

Policy 1.6.4

The City should consider changes to the Zoning and Land Development Code and Future Land Use categories to permit mixed-use development in proximity to the FEC railway, major transit corridors and within the City's redevelopment area.

Policy 1.6.5

Create mixed-use land use categories including a MU/Town Center; MU/Employment Center, MU/Neighborhood Center; MU/Corridor and MU/Waterfront to facilitate and encourage the creation of beautiful, safe and livable places in the downtown and along major corridors including West Dixie Highway, Hanford Boulevard, 19th Avenue, Biscayne Boulevard and 163rd Street.

Policy 1.6.6

The Mixed-Use/Town Center (MU/TC) land use designation is hereby created to encourage transit-oriented development that is consistent with an urban downtown including corporate office, ground floor retail, upper floor or stand-alone residential and other nonresidential uses as specified in the appropriate zoning district. New stand-alone auto-oriented uses are not intended for development within the MU/TC land use category such as: large surface parking lots (except park and ride lots), gas stations/auto repair/car washes; auto dealers; self/equipment storage; conventional suburban "big box"/warehouse; single-family detached dwelling units; stand-alone carwashes; and similar auto-oriented uses.

Policy 1.6.7

The Mixed-Use/Employment Center (MU/EC) land use designation is hereby created to permit economic development supportive of high technology and service-based activities that are compatible with residential uses as specified in the appropriate zoning district in the Land Development Code. Limited auto-oriented uses are considered acceptable in this district but are required to be designed in a manner that encourages pedestrian and transit use. Mixed-use may be vertically or horizontally integrated based on compatibility and other factors. Stand-alone office park-style development as well as live-work buildings are equally appropriate in this district as are stand-alone residential buildings.

Policy 1.6.8

The Mixed-Use/Neighborhood Center (MU/NC) land use designation is hereby created to support a balanced mix of land uses characterized by compactness, pedestrian friendly design, neighborhood-scale and framed by architecture and landscape design appropriate to local history and the natural environment. Development patterns shall generally reflect planning and design principles such as walkable neighborhoods oriented around the five-minute walk, primary orientation towards public transit systems, a centrally located community-serving land use or land uses and greater integration of housing, employment, shopping and recreation at the neighborhood level. A MU/NC shall be a specific geographic area not exceeding 80 gross contiguous acres, unless located within an approved Community Redevelopment Area. Permitted

uses within a MU/NC shall include residential uses and park land and/or open space, and must include one or more other uses such as commercial, civic, institutional, or employment based uses.

Policy 1.6.9

The Mixed-Use/Waterfront District (MU/WF) is similar in intent as the MU/NC, however, it must be located on a significant water body and be designed to maximize the economic and aesthetic resource created by its waterfront location. Public access to and beautification of the waterfront is a primary principal of the MU/WF district while also providing for multi-family housing that enables residents to live on the waterfront. Development patterns shall generally reflect planning and design principles such as walkable neighborhoods oriented around the five minute walk, primary orientation towards the waterfront, integration of housing, employment, shopping and recreation at the neighborhood level. Permitted uses within a MU/WF shall include residential uses and park land and/or open space, and must include one or more other uses such as commercial, civic, institutional, or employment-based uses. Every project adjacent to the water in a MU/WF district will be encouraged to provide one or more public access-ways to the waterfront with the intent to create public, active waterfront uses along all or the majority of the waterfront with pleasing views from both the land-side and water-side of the development.

Policy 1.6.10

The Mixed-Use/Corridor (MU/C) is a mixed-use district intended to capitalize on its location on a primary transit and business corridor and is created to permit economic development to support both local and regional activity and provide a variety of workforce and market rate housing opportunities. Auto-oriented uses are considered acceptable in this district but are required to be designed in a manner that encourages pedestrian and transit use. Mixed-use may be vertically or horizontally integrated based on compatibility and other factors. Stand-alone office park-style development, big box retail establishments and stand-alone residential buildings are equally appropriate in this district.

Objective 1.12

Provide for land use categories in the Future Land Use Element and Map that allow for the continued redevelopment and development of housing at a variety of densities and appropriate for the full range of incomes and lifestyles. Measure: This objective shall be implemented by its policies to provide sufficient housing types, including affordable housing.

Transportation Element

Goal 1

To maintain a financially feasible, multimodal, urban transportation system that meets the mobility needs of the residents in a safe and efficient manner, and that operates in harmony with the existing and future land use pattern and the environment.

Objective 1.5 Pedestrian/Bicycle Systems

The City will continue to develop methods of providing a safer, more convenient, non-motorized circulation system.

Policy 1.2.7

The City, through the land development regulations, will continue to require all development and redevelopment projects to provide a sufficient number of parking spaces for both motorized and non-motorized vehicles. The City will periodically review the off-street parking requirements and evaluate the adoption of parking reductions within mixed-use areas for developments of sufficient intensity to support transit, and where TDM strategies such as ridesharing, shuttle service, and incentives for transit use are implemented consistent with Policy 1.1.3.

Policy 1.2.8

The City will ensure that the design of new and redevelopment mixed-use projects are conducive to pedestrian, bicycle and transit use. At a minimum other new development and redevelopment projects will address development intensity and mix of land uses, building and parking lot orientation, bicycle storage, connectivity of pedestrian and bicycle infrastructure, and pedestrian amenities to enhance multimodal transportation alternatives.

Policy 1.2.10

The City shall seek to limit greenhouse gas emissions through the implementation of strategies to reduce the number of vehicle miles travelled. These strategies may include but are not limited to: the promotion of compact mixed-use development that provides for a mixture of residential and nonresidential land uses in a pedestrian friendly environment with multi-modal transportation connectivity to other areas; promoting the use of alternate transportation modes as specified herein, including mass transit, bicycles, and pedestrianism, and; requiring Transportation Demand Management Programs as a condition for development approvals. The City will require development in the redevelopment areas to promote mixed-use development, defined as design unified, vertically and or horizontally integrated, pedestrian-friendly development. Mixed-use areas should provide for multi-modal transportation connectivity to other areas, encourage mass transit, reduce the need for automobile travel, provide incentives for quality development, and give definition to the urban form.

Policy 1.2.11

In the event that the proposed high speed rail line is constructed, the City should consider encouraging the location of a station within its boundaries.

Policy 1.4.6

Long term strategies for the North Miami Beach circulator bus service include: improved connectivity to the Golden Glades Intermodal terminal, and other transportation modes, through express service to the terminal, the accommodation of bicycles, and bus stop benches and shelter; improved service to commercial and mixed-use districts and employment centers, and; acquisition of distinctive, alternatively fueled vehicles such as trolleys.

Policy 1.4.9

The City will cooperate with MDTA in the development of multi-modal transit facilities along the Biscayne Boulevard/ U.S. 1 and/or North Miami Beach Boulevard corridors by ensuring that the City's Future Land Use Element and land development regulations encourage development of appropriate design, intensity, urban context, and mix of uses which will support usage of, and complement, these facilities. This policy shall be implemented in part through FLUE Policy 1.8.1 and Transportation Policy 1.1.3.

Policy 1.4.11

The City shall coordinate the infilling and redevelopment of the Fulford City Center and other portions of the Community Redevelopment Area with the MPO to best ensure that transit service keeps pace with the demand and feasibility of mass transit created by the additional residential units and nonresidential growth that will be located conveniently to MDTA transit routes and proposed transit centers.

Policy 1.4.13

The City shall continue to support the establishment of FEC commuter rail service, and shall promote the location of a rail station within the City to further strengthen the transit alternatives and convenience of using transit from within and around the City.

Policy 1.4.15

The City shall coordinate with the MPO to seek provision of bus shelters at all bus stops within the Fulford City Center, the remainder of the Community Redevelopment Area, and along NMBB and US-1.

Policy 1.5.2

The City will maintain its Greenway Corridor and bicycle path along the Snake Creek Canal as a linear natural area consisting of environmentally sensitive lands and recreation opportunities and extend this corridor when funds and additional public land becomes available.

Policy 1.5.3

The City will seek to expand the existing Greenway Corridor and bicycle path through the implementation of appropriate improvements, including the construction of additional paths where feasible and appropriate. (Ref. Map 2.6)

Policy 1.5.4

The City will continue to implement improvements to the Greenway Corridor and existing bike path and construct additional linear paths to establish connectivity with various recreational areas within the City. (Ref. Map 2.6)

Policy 1.5.5

Where appropriate, the City will require new development and redevelopment to provide sidewalks abutting public streets adjacent to the development.

Policy 1.5.6

The City shall encourage the establishment of bicycle rental and repair services within the Fulford City Center area.

Objective 1.6 Land Use/Transportation Compatibility

The Transportation Element will be compatible with the Future Land Use Element and other elements of the plan ensuring that the transportation system meets the current and future needs of the population and land use patterns of North Miami Beach.

Policy 1.6.3

The City will maintain the mixed-use category in the Future Land Use Element to allow maximum flexibility for redevelopment projects so as to reduce traffic impacts and encourage transit usage. Development standards for mixed-use development will permit the density and intensity needed to support transit in existing and planned transit corridors.

Policy 1.6.4

The City will allow sufficient densities along major roadway corridors to support transit where appropriate. The City will evaluate applications for amendments to the Future Land Use Map within existing and planned transit corridors for compatibility of intensity and type of use with transit usage.

Policy 1.6.5

The City supports the development of multimodal transit facilities along the Biscayne Boulevard/U.S. 1 corridor, and will cooperate with Miami-Dade County for the development of such facilities in alternative locations. The City will provide conditions conducive to redevelopment of the area around these transit facilities that will enhance and encourage transit usage. In support of these efforts, the City will provide the County with requested information regarding existing and potential types, densities and intensities of land use upon request.

Housing Element Goals, Objectives, and Policies

Policy 1.1.1

In order to accommodate the market as it responds to the increased demand for a diversity of housing types, including middle, low, and very low income single-family housing units, the City should investigate the possibility of identifying areas where changes to future land use designations, density and intensity restrictions, land development regulations, and urban design principles would be appropriate. In accordance with the Coastal Management Element, density and intensity increases shall not be considered in the Coastal High Hazard Area.

Policy 1.4.1

The City shall support efforts to bring rental units within the reach of low and moderate income households, with a particular focus on infill lots and redevelopment areas west of Biscayne Boulevard.

Objective 1.7 Intergovernmental Coordination

The City will have a system which ensures that all transportation requirements, procedures and improvements are coordinated with all applicable government entities responsible for transportation activities.

Policy 1.7.1

The City will coordinate with Miami-Dade County MPO in its transportation planning activities. This coordination effort will include participation in the MPO Technical Coordinating Committee.

Policy 1.7.2

The City will participate in all corridor studies impacting North Miami Beach initiated or undertaken by FDOT and/or Miami-Dade County.

Policy 1.7.6

The City will support public transit by coordinating with Miami-Dade County for the placement and operation of multi-modal transit facilities along the Biscayne Boulevard/U. S. 1 corridor.

Policy 1.7.8

The City will coordinate with the Florida Department of Transportation Five-Year Work Program through annual reviews in order to ensure consistency between FDOT's Work Program and the City's comprehensive and transportation planning.

Infrastructure Element Goals, Objectives, and Policies

Goal 1

To provide and maintain public infrastructure in a manner that will insure the public health, safety and quality of life.

Objective 1.1

Continue to provide new or improved sewer collection, drainage and/or potable water systems in accordance with its adopted Level of Service standards.

Policy 1.1.1

The City shall ensure provision of sanitary sewer service in accordance with its adopted Level of Service standard.

Goal 2

To provide and maintain the public infrastructure in a manner that will insure public health, safety and quality of life.

Policy 1.1.2

The City shall continue its drainage improvement program and continue the supporting catch basin cleaning program so that adequate street drainage can be achieved and maintained.

Objective 1.2

The City shall provide an adequate level of service during the planning period.

Policy 1.2.1

Sanitary Sewer: The sanitary sewer collection system within the City shall accommodate an average daily flow of at least 85 gallons per person per day. The County treatment and disposal system shall operate with a design capacity of 2% above the daily flow of the preceding year. Otherwise, septic tanks shall be the level of service.

Policy 1.2.2

Solid waste: The City's trucks and the County disposal system shall accommodate 5.5 pounds per capita per day.

Policy 1.2.3

Drainage: The City's storm drainage facilities shall accommodate runoff from a one-day storm that statistically occurs once in ten years.

Policy 1.2.4

Potable Water: the City's water system shall provide 150 gallons per person per day at a pressure of 40 pounds per square inch.

Objective 1.3

Maintain and expand water conservation programs.

Objective 1.4

Protect the City's natural drainage and recharge areas by retaining all existing lakes and prohibiting any new development with 100 percent impervious coverage.

Objective 1.6

Incorporate and provide particular support to South Florida Regional Planning Council Goals 2.2 and 2.3 and Policies 2.2.1, 2.2.1, 2.3.11 and 2.2.15, which read as follows:

SFRPC Strategic Regional Goal 2.2

Revitalize deteriorating urban areas.

SFRPC Strategic Regional Policy 2.2.1

Strategic Regional Policy 2.2.1 – Give priority to development in areas that are blighted, characterized by underdevelopment or underemployment and are in need of redevelopment. Among these, secondary priority should be given to areas within which adequate infrastructure and support services are either programmed or available.

SFRPC Strategic Regional Goal 2.3

Enhance the economic competitiveness of the region and ensure the adequacy of its public facilities and services by eliminating the existing backlog, meeting the needs for growth in a timely manner, improving the quality of services provided and pursuing cost-effectiveness and equitability in their production, delivery, and financing.

SFRPC Strategic Regional Policy 2.3.11

Give priority to the construction, maintenance or reconstruction of public facilities needed to serve existing development most effectively.

SFRPC Strategic Regional Policy 2.3.15

Impact review procedures shall consider the impacts of development on state, regional and local public facilities and services.

Capital Improvement Element Goals, Objectives and Policies

Goal 1

To undertake capital improvements necessary to keep its present public facilities in good condition and to accommodate new development, within sound fiscal practices.

Objective 1.1

The City Manager shall continue to monitor public facilities as a basis for annual recommendations to the City Council in the form of a five-year Capital Improvement Program (CIP).

Policy 1.1.1

Comprehensive Plan Data and Analyses and /or staff and engineering studies which include analyses of maintenance and operation costs shall form the basis for the annual preparation of the five-year Capital Improvement Program. No capital improvement expenditure shall be included in the CIP unless and until such improvement is consistent with the Goals, Objectives, and Policies of the Comprehensive Plan and specifically supported by at least one Comprehensive Plan Policy. Each Department Head, as part of annually preparing and submitting his or her Department's five-year CIP proposal to the City Manager, shall insure that the Comprehensive Plan supports each proposed expenditure OR is scheduled to be amended so as to support each proposed expenditure. Funds for capital improvements shall not be budgeted unless funds for maintenance and operation are also budgeted.

Policy 1.1.2

Include in the annual capital improvement programming process a systematic replacement of equipment, infrastructure, and facilities as required to maintain existing services and operations and as needed to improve the security, safety, accessibility and efficiency of those services and operations.

56

Policy 1.1.3

In annually setting priorities, the following prioritized criteria will be used by the City Manager and City Council.

- Public Safety implications: a project to address a threat to public safety will receive first priority. All elements.
- Level of service or capacity problems; next in priority would be projects needed to maintain the stated Level of Service. Traffic, Infrastructure and Recreation Elements.
- Redevelopment: Does it further one of the redevelopment areas or enhance the tax base through new development? Land Use Element
- Ability to finance: A third criterion is the budgetary impact; will it exceed budget projections? All Elements
- Quality of life projects: lowest priority would be those projects not in the above categories but that would enhance the quality of life. All Elements except Land Use.
- State or other public jurisdictions: does it further one of their projects. All Elements except Land Use.

Redevelopment Plan Amendment Process

The CRA Plan shall be in effect for a maximum of thirty years from the date of the adoption of the initial CRA Plan (adopted February 2005). Extensions shall be allowed as provided by State Statute and the Miami-Dade County Board of County Commissioners ("County"). Initially the Agency was created by the County to have a 10-year life span. Subsequently the life span has been modified by the County and the County retains the power to create further modifications in this regard in accordance with State Statute.

The CRA Plan may need to be amended in order for it to maintain its relevance and currency to respond to priorities as they emerge, to serve new Redevelopment Area, and to add needed specificity as projects, tax increment revenues, and expenditures are defined in more detail over time. The Agency and City shall consider amendments in 5-year intervals.

Amendments to the CRA Plan can be recommended by the Board. The recommended CRA Plan amendment must be consistent with the City of North Miami Beach's Comprehensive Plan, as recommended by the Planning and Zoning Board. The Agency will initiate any amendment action by creating a Resolution and recommending that the City Council approve the amendment. The Agency may then hold an advertised public hearing on the proposed modification or amendment and approve the modification by passage of an appropriate Resolution. Any Plan amendments shall be subject to County review and approval as per the terms of the adopted Interlocal Agreement (Appendix "A"). Any amendment action may also require pre-notification of the affected taxing authorities by registered mail.

If any provision of this CRA Plan or subsequent amendments shall be found to be invalid, unconstitutional or otherwise legally infirm, such provision shall not affect the remaining portions of the CRA Plan. All amendments to the CRA Plan are subject to County approval.

This amendment process is governed by state statutes which may change over the lifetime of the Plan. Therefore, the statute shall be overriding guide to all amendment procedures. Section 163.361 is included below.

163.361 Modification of community redevelopment plans

(1) If at any time after the approval of a community redevelopment plan by the governing body it becomes necessary or desirable to amend or modify such plan, the governing body may amend such plan upon the recommendation of the agency. The agency recommendation to amend or modify a redevelopment plan may include a change in the boundaries of the redevelopment area to add land to or exclude land from the redevelopment area, or may include the development and implementation of community policing innovations.

(2) The governing body shall hold a public hearing on a proposed modification of any community redevelopment plan after public notice thereof by publication in a newspaper having a general circulation in the area of operation of the agency.

(3)(a) In addition to the requirements of s. 163.346, and prior to the adoption of any modification to a community redevelopment plan that expands the boundaries of the community redevelopment area or extends the time certain set forth in the redevelopment plan as required by s. 163.362(10), the agency shall report such proposed modification to each taxing authority in writing or by an oral presentation, or both, regarding such proposed modification.

(b) For any community redevelopment agency that was not created pursuant to a delegation of authority under s. 163.410 by a county that has adopted a home rule charter and that modifies its adopted community redevelopment plan in a manner that expands the boundaries of the redevelopment area after October 1, 2006, the following additional procedures are required prior to adoption by the governing body of a modified community redevelopment plan:

1. Within 30 days after receipt of any report of a proposed modification that expands the boundaries of the redevelopment area, the county may provide notice by registered mail to the governing body of the municipality and the community redevelopment agency that the county has competing policy goals and plans for the public funds the county would be required to deposit to the community redevelopment trust fund under the proposed modification to the community redevelopment plan.

2. If the notice required in subparagraph 1. is timely provided, the governing body of the county and the governing body of the municipality that created the community redevelopment agency shall schedule and hold a joint hearing co-chaired by the chair of the governing body of the county and the mayor of the municipality, with the agenda to be set by the chair of the governing body of the county, at which the competing policy goals for the public funds shall be discussed. For those community redevelopment agencies for which the board of commissioners of the community redevelopment agency are comprised as specified in s. 163.356(2), a designee of the community redevelopment agency shall participate in the joint meeting as a nonvoting member. Any such hearing shall be held within 90 days after receipt by the county of the recommended modification of the adopted community redevelopment plan. Prior to the joint public hearing, the county may propose an alternative modified community redevelopment plan that meets the requirements of s. 163.360 to address the conditions identified in the resolution making a finding of necessity required under s. 163.355. If such an alternative modified redevelopment plan is proposed by the county, such plan shall be delivered to the governing body of the municipality that created the community redevelopment agency and the executive director or other officer of the community redevelopment agency by registered mail at least 30 days prior to holding the joint meeting.

3. If the notice required in subparagraph 1. is timely provided, the municipality may not proceed with the adoption of a modified plan until 30 days after the joint hearing unless the governing body of the county has failed to schedule or a majority of the members of the governing body of the county have failed to attend the joint hearing within the required 90-day period.

4. Notwithstanding the time requirements established in subparagraphs 2. and 3., the county and the municipality may at any time voluntarily use the dispute resolution process established in chapter 164 to attempt to resolve any competing policy goals between the county and municipality related to the community redevelopment agency. Nothing in this subparagraph grants the county or the municipality the authority to require the other local government to participate in the dispute resolution process.

(4) A modification to a community redevelopment plan that includes a change in the boundaries of the redevelopment area to add land must be supported by a resolution as provided in s. 163.355.

(5) If a community redevelopment plan is modified by the county or municipality after the lease or sale of real property in the community redevelopment area, such modification may be conditioned upon such approval of the owner, lessee, or successor in interest as the county or municipality may deem advisable and, in any event, shall be subject to such rights at law or in equity as a lessee or purchaser, or his or her successor or successors in interest, may be entitled to assert.

Neighborhood Impact of Programs

Land Use, Zoning and Development Approvals

At the time of the adoption of the CRA Plan, the Agency shall conform to all pertinent laws, land development regulations, the existing Comprehensive Plan, ordinances and resolutions of the City of North Miami Beach as they relate to the approval of required permits or development orders for Agency-initiated projects which require such approvals.

Effect on Traffic

It is the intent of the Agency to promote and improve safe, efficient, and convenient traffic circulation throughout and within the Redevelopment Area. As the existing roadway network provides considerable connectivity with arterials and connectors, the Agency shall emphasize the need to improve those roadways within the Redevelopment Area. The Agency shall also serve as an advocate for aggressive grant and state funding for roadway and traffic circulation improvements.

Effect on Community Facilities

Any existing community facilities within the boundary of the Redevelopment Area may benefit from the economic improvement of the area by the implementation of the redevelopment initiatives, and the physical improvements of the surrounding area that will create economic revitalization with the advent of new businesses and job opportunities. Community services such as innovative policing and code enforcement can be expanded utilizing the programs included in the CRA Plan.

Effect on Schools

There are no public schools located within the Redevelopment Area. Fulford Elementary is located adjacent to the CRA, between NE 160th and 161st Streets on NE 18th Avenue. The CRA will have no physical impacts on this school property. The Plan does contemplate the development of additional housing units in the Redevelopment Area, including mixed use and multi-family projects. As a result, there likely will be some increase in school population. At this time, however, it is not possible to calculate how much of an increase. Future impacts generated by redevelopment will be reviewed on a case-by-case basis as part of the project approval required by the City's Comprehensive Plan and related concurrency regulations.

In anticipation of the possible need for additional school space, the Plan provides that the Agency will be empowered to provide financial support for development of charter school plant facilities. All CRA initiatives are subordinate to the State Statutes, the City's Comprehensive Plan, the Land Development Regulations, or any County-wide concurrency guidelines.

Appendix A – Interlocal Agreement

Please see following pages.

SIGNED

INTERLOCAL COOPERATION AGREEMENT

THIS INTERLOCAL COOPERATION AGREEMENT (the "Agreement"), made this 11 day of Oct, 2005 by and between Miami-Dade County, Florida, a political subdivision of the State of Florida (the "County"), the City of North Miami Beach, Florida, a municipal corporation under the laws of the State of Florida (the "City") and the North Miami Beach Community Redevelopment Agency, or its successor, a public body corporate and politic (the "Agency").

WHEREAS, the Mayor and City Council adopted Resolution No. 2004-57 on September 14, 2004, providing a Finding of Necessity declaring that a blighted area, as defined in Section 163.340, Florida Statutes, exists within the City's boundaries; and

WHEREAS, the Mayor and City Council further declared in Resolution No. 2004-57 that the rehabilitation, conservation, redevelopment, or a combination thereof, of such area is necessary in the interest of the public health, safety, morals, or welfare of the residents of the City of North Miami Beach; and

WHEREAS, the Board of County Commissioners of Miami-Dade County, Florida (the "Board") adopted Resolution R-1345-04 on November 30, 2004, which, among other things, declared that a slum or blighted area existed in a geographic area, more particularly described in Exhibit "1" (the "Redevelopment Area"), determined that it was necessary to redevelop such Redevelopment Area in accordance with the provisions of Part III of Chapter 163, Florida Statutes (the "Act"), and delegated to the City Council of the City of North Miami Beach, Florida (the "City Council") the authority to exercise the redevelopment powers conferred upon the Board within the Redevelopment Area in accordance with the Act to enable the City Council to declare the need-for, create and delegate powers to a community redevelopment agency and to initiate, prepare and adopt a plan of redevelopment for final approval by the Board; and

WHEREAS, the City Council, pursuant to Resolution R2004-86 adopted on December 21, 2004, accepted a delegation of powers from the Board, found a need for and created the Agency, declared the members of the City Council to be the members of the Agency, granted the Agency the power to exercise all powers permitted by the Act which were delegated by the Board to the Agency and directed the initiation, preparation and adoption of a community redevelopment plan by the Agency; and

WHEREAS, the Mayor and City Council adopted on February 1, 2005, resolution R2005-05 giving final approval to the community redevelopment agency's community redevelopment plan; and

WHEREAS, pursuant to Resolution R-611-05 adopted on June 7, 2005 the Board has approved the North Miami Beach Community Redevelopment Plan (the "Plan") to enable the City to undertake redevelopment of the Redevelopment Area; and

WHEREAS, pursuant to Ordinance 05-110 adopted on June 7, 2005 the Board has approved the creation of a community redevelopment trust fund known as the North Miami Beach Community Redevelopment and Revitalization Trust Fund (the "Fund") which provides for the calculation and appropriation of tax increment funds; and

WHEREAS, the boundaries identified for the Redevelopment Area are within the corporate limits of the City; and

WHEREAS, the City played the major role in the preparation of the Plan; and

WHEREAS, the County, the City and the Agency desire to delineate their areas of responsibility with respect to the redevelopment of the Redevelopment Area.

WITNESSETH, that for and in consideration of the mutual covenants and agreements contained herein, the County, the City and the Agency agree as follows:

I. Delegation of Powers

A. With the exception of the community redevelopment powers that continue to vest in the Board pursuant to Section 163.358, Florida Statutes the Board hereby delegates to the City Council, acting either directly or through the Agency, the sole right and responsibility to exercise only the following specifically delineated redevelopment powers:

(1) The power to make and execute contracts and other instruments necessary or convenient to the exercise of its powers pursuant to the Act.

(2) The power to disseminate slum clearance and community redevelopment information.

(3) The power to undertake and carry out community redevelopment and related activities within the Redevelopment Area, which redevelopment may include:

- (a) Acquisition of a slum area or a blighted area or portion thereof;
- (b) Demolition and removal of buildings and improvements,
- (c) Installation, construction, or reconstruction of streets, utilities, parks, playgrounds, and other improvements necessary for carrying out in the Redevelopment Area the community redevelopment objectives of the Act in accordance with the Plan;
- (d) The power to dispose of any property acquired in the Redevelopment Area at its fair value for uses in accordance with the Plan;
- (e) The power to carry out plans for a program of voluntary or compulsory repair and rehabilitation of buildings or other improvements in accordance with the Plan;
- (f) The power to acquire real property in the Redevelopment Area which, under the Plan, is to be repaired or rehabilitated for the dwelling use or related facilities, repair or rehabilitation of tile structures for guidance purposes, and resale of the property;
- (g) The power to acquire any other real property in the Redevelopment Area when necessary - to eliminate unhealthful, unsanitary, or unsafe conditions; lessen density; eliminate obsolete or other-uses detrimental to the public welfare; or otherwise to remove or prevent the spread of blight or deterioration or to provide land for needed public facilities;

- (h) The power to acquire without regard to any requirement that the area be a slum or blighted area, air rights in an area consisting principally of land in highways, railway or subway tracks, bridge or tunnel entrances, or other similar facilities which have a blighting influence on the surrounding area and over which air rights sites are to be developed for the elimination of such blighting influences and for the provision of housing (and related facilities and uses) designed specifically for, and limited to, families and individuals of low or moderate income;
- (i) The power to construct foundations and platforms necessary for the provision of air rights sites of housing (and related facilities and uses) designed specifically for and limited to, families and individuals of low or moderate income.

(4) The power to provide, or to arrange or contract for, the furnishing or repair by any person or agency, public or private, of services, privileges, works, streets, roads, public utilities, or other facilities for or in connection with a community redevelopment; to install, construct, and reconstruct streets, utilities, parks, playgrounds, and other public improvements; and to agree to any conditions that it deems reasonable and appropriate which are attached to federal financial assistance and imposed pursuant to federal law relating to the determination of prevailing salaries or wages or compliance with labor standards, in the undertaking or carrying out of a community redevelopment and related activities, and to include in any contract let in connection with such redevelopment and related activities provisions to fulfill such of the conditions as it deems reasonable and appropriate

(5) Within the Redevelopment Area:

- (a) The power to enter into any building or property in the Redevelopment Area in order to make inspections, surveys, appraisals, soundings, or test borings and to obtain an order for this purpose from a court of competent jurisdiction in the event entry is denied or resisted;
- (b) The power to acquire by purchase, lease, option, gift, grant, bequest, devise, or otherwise any real property (or personal property for its administrative purposes), together with any improvements thereon, except that the County shall continue to retain all powers with respect to the use of eminent domain;
- (c) The power to hold, improve, clear, or prepare for redevelopment any such property;
- (d) The power to mortgage, pledge, hypothecate, or otherwise encumber or dispose of any real property;

- (e) The power to insure or provide for the insurance of any real or personal property or operations of the City against any risks or hazards, including the power to pay premiums on any such insurance;
- (f) The power to enter into any contracts necessary to effectuate the purposes of the Act;
- (g) The power to solicit requests for proposals for redevelopment of parcels of real property contemplated by the Plan to be acquired for redevelopment purposes by the Agency and, as a result of such requests for proposals, to advertise for the disposition of such real property to private persons pursuant to Section 163.380, Florida Statutes, prior to acquisition of such real property by the Agency; and

(6) The power to invest any community redevelopment funds held in reserves or sinking funds or any such funds not required for immediate disbursement in property or securities in which savings banks may legally invest funds subject to their control and to redeem such bonds as have been issued pursuant to Section 163.385, Florida Statutes, at the redemption price established therein or to purchase such bonds at less than the redemption price, all such bonds so redeemed or purchased to be cancelled.

(7) The power to borrow money and to apply for and accept advances, loans, grants, contributions, and any other form of financial assistance from the Federal Government or the state, county, or other public body or from any sources, public or private, for the purposes of the Act, and to give such security as may be required and to enter into and carry out contracts or agreements in connection therewith; and to include in any contract for financial assistance with the Federal Government for or with respect to community redevelopment and related activities such conditions imposed pursuant to federal laws as the County and/or the City deems reasonable and appropriate which are not inconsistent with the purposes of the Act.

(8) Within its area of operation, the power to make or have made all surveys and plans necessary to the carrying out of the purposes of the Act; to contract with any person, public or private, in making and carrying out such plans; and to adopt or approve, modify, and amend such plans, which plans may include, but are not limited to:

- (a) Plans for carrying out a program of voluntary or compulsory repair and rehabilitation of buildings and improvements;
- (b) Plans for the enforcement of state and local laws, codes, and regulations relating to the use of land and the use and occupancy of buildings and improvements and to the

compulsory repair, rehabilitation, demolition, or removal' of buildings and improvements;

- (c) Appraisals, title searches, surveys, studies, and other plans and work necessary to prepare for the undertaking of community redevelopment and related activities.

(9) The power to develop, test, and report methods and techniques, and carry out demonstrations and other activities, for the prevention and the elimination of slums and urban blight and developing and demonstrating new or improved means of providing housing for families and persons of low income.

(10) The power to apply for, accept, and utilize grants of funds from the Federal Government for such purposes.

(11) The power to prepare plans for and assist in the relocation of persons (including individuals, families, business concerns, nonprofit organizations, and others) displaced from the Redevelopment Area and to make relocation payments to or with respect to such persons for moving expenses and losses of property for which reimbursement or compensation is not otherwise made, including the making of such payments financed by the Federal Government.

(12) The power to appropriate such funds and make such expenditures as are necessary to carry out the purposes of the Act subject to the County's, review and approval of the Agency's annual budget or any requested budget amendments, to zone or rezone any part of the City or make exceptions from building regulations pursuant to applicable law; and to enter into agreements with a housing authority, which agreements may extend over any period, notwithstanding any provision or rule of law to the contrary, respecting action to be taken by the City pursuant to any of the powers granted by the Act.

(13) The power to close, vacate, plan, or replan streets, roads, sidewalks, ways, or other places and to plan or replan any part of the City.

(14) Within its area of operation, the power to organize, coordinate, and direct the administration of the provisions of the Act as they may apply to the City, in order that the objective of remedying slum and blighted areas and preventing the causes thereof within the City may be most effectively promoted and achieved and to establish such new office or offices of the City or to reorganize existing, offices in order to carry out such purpose most effectively.

(15) The power to exercise all or any part or combination of powers herein granted or to elect to have such powers exercised by the Agency.

B. All powers not specifically listed in this section I(A) are reserved to the Board, including, but not limited to the power to issue bonds pledging TIF revenues, the power to use eminent domain to acquire properties, the power to implement community policing programs, and the power to change the composition of the CRA Board.

II. Implementation of the Plan

A. The Redevelopment powers listed in Section I. herein may be exercised only with respect to the Area and only with respect to the Plan as adopted by the Agency, adopted by the City Council and approved by the Board, together with any supplements or amendments to the Plan, provided that any amendments and supplements to the Plan must also be approved by the Board. The City and the Agency hereby expressly agree that the Plan as approved by the Board pursuant to Resolution 611-05 is for a period of ten (10) years.

B. No more than twenty percent (20%) of the funds contemplated to be expended under the Plan shall be used for total administrative expenses allowable under Section 163.387(6)(a), Florida Statutes. No more than six percent (6%) of the funds contemplated to be spent under the Plan shall be allocated to indirect and overhead expenses as those terms are generally understood. The County shall charge, and the Agency shall pay, to the County an annual administrative fee ("County Administrative Fee"). The fee shall be based on a percentage of the County's TIF payment to the agency and shall be determined annually by the County. The percentage charged by the County shall be the same for all CRAs within the County. The County administrative fee shall not be included in the (20%) limit on administrative expenses defined in this section.

C. The City shall, either directly or through the Agency, ensure that the staff of the Agency be racially and ethnically diverse, all in accordance with applicable law.

III. City/County Coordination

A. The County Manager shall designate a Redevelopment Area Coordinator (the "Redevelopment Area Coordinator"). The Redevelopment Area Coordinator shall serve as the County's liaison to the City and the Agency for the Redevelopment Area. The Redevelopment Area Coordinator shall carry out the day-to-day County responsibilities for the Redevelopment Area and shall be the designated person to receive all data and reports pertaining to the Plan.

B. The City, either directly or through the Agency, shall be responsible for implementing and conforming to the Plan. The City's responsibilities with respect to implementation of the plan (acting either directly or through the Agency), shall include developing and implementing proposals for indebtedness and bond financing (subject to County approval, which approval the County may grant or deny in its sole and absolute discretion and the limitations contained herein), acquisition, disposition and relocation activities, eminent domain activities (subject to County approval which approval the County may grant or deny in its sole and absolute discretion and the limitations contained herein), coordination and implementation of the design and construction of public improvements necessary to support the redevelopment of the Redevelopment Area, and such other projects and activities as are contemplated by the Plan. The City, either directly or through the Agency, shall deliver copies of all accepted proposals for the Redevelopment Area to the Redevelopment Area Coordinator. All CRA projects and proposals must be identified and budgeted for in the annual plan and budget, which remains subject to County approval. Justification as to how each new project and proposals conform with the Goals and elements contained in the plan shall be provided to County staff upon request.

C. The Redevelopment Area Coordinator shall submit all proposals related to amendments to the Plan and proposals for indebtedness and bond financing to the

County Manager's Tax Increment Financing and Coordinating Committee (the "TIFC Committee"), which Committee shall review and make recommendations to the County Manager on modifications and amendments to the Plan and all proposals for indebtedness and bond financing for the Redevelopment Area. The Redevelopment Area Coordinator shall review all proposals prior to review by the TIFC Committee and the Board.

D. An annual budget and a separate report of activities for the preceding year shall be submitted to the County not later than forty (45) days prior to the beginning of each County fiscal year in a format approved by the County. The format shall contain provisions for descriptions and justifications for both annual and multi-year project costs and require explanations and justifications for all inter-agency or intergovernmental charge or allocations. In the event that changes in the millage rates require modification of the submitted budget, such budget shall be submitted on or before the 15th day of the fiscal year. The annual budget for the Agency and the Redevelopment Area shall be adopted by the Agency and City prior to review and approval by the Board. With the exception of the debt service payment on existing bond obligations financed by tax increment revenues, no funds on deposit in the Fund may be expended by the City Commission or the Agency, as the case may be, until the annual budget has been approved by the Board. The TIFC Committee shall initially review the budget and submit recommendations to the County Manager for review and to the Board for final approval. At the request of the County, the City or the Agency shall submit additional progress reports on the Plan and Redevelopment Area activities.

E. Once the Board approves and adopts any amendments and modifications to the Plan, such amendments and modifications shall become a part of the Plan and the powers delegated to the City Council pursuant to this Agreement, shall be exercisable either directly or through the Agency, with respect to such amendments and modifications.

IV. Land Disposition

A. Any disposition of land for the Redevelopment Area shall be accomplished in accordance with applicable provisions of federal, state and local law, established City guidelines, the Plan and this Agreement pursuant to the Act.

V. Other Redevelopment Area Activity

A. The City, either directly or through the Agency, shall be responsible for the administration and funding of all relocation activities. Six months prior to the commencement of redevelopment activities which may result in the displacement of persons, the City, either directly or through the Agency, shall establish residential relocation procedures for the relocation of such persons (the "Local Relocation Procedures") and shall submit such Local Relocation Procedures to the Board for review and approval. In addition to any applicable federal, State or local law, the Local Relocation Procedures shall apply in all relocation cases within the Redevelopment Area, provided, however, if federal funds are received by the City, either directly or through the Agency, for a project which requires residential relocation, the City, either directly through the Agency, shall follow the relocation procedures set forth in the Uniform Relocation Assistance and Real Property Acquisition Policies Act of 1970, 42 United States Code, Chapter 61, Section 4601, et seq. and Section

104 (d) of the Housing and Community Development Act of 1974, and as such may be amended. The City, and or Agency, may contract with County agencies to assist in residential relocation.

B. The City, either directly or through the Agency, shall cause an annual report of activities for the preceding fiscal year, which report shall include a complete financial statement setting forth its assets, liabilities, income and operating expenses as of the end of such fiscal year to be filed with the County on, or before March 31 of each year. Also, the City, either directly, or through the agency, shall cause an independent audit by a Certified Public Accounting firm to be performed on an annual basis, a copy of which is to be forwarded to the Board by the first of March of the following year. The preceding requirements must conform, or be compliant with, Sections 163.356 (c), and 163.387 (8) Florida Statutes and any reporting request subsequently made by the Controller General of the State of Florida.

C. All redevelopment activities conducted with respect to the Redevelopment Area shall be in conformance with the Plan as the same may be amended. Any amendments to the Plan as required by Section 163.361, Florida Statutes, must have prior approval of the Board before the City, either directly or through the Agency, may implement the change contemplated by the amendments. Once approved, however, the City, either directly or through the Agency, may implement the amendments thereto.

D. The City or the Agency, as the case may be shall include language in any loan agreement, grant agreement or other agreements or contracts entered into between the City or the Agency and business involved in the redevelopment effort of the Redevelopment Area which states that, as a condition to the business' receipt of monies or incentives from the City or the Agency, any new jobs created as a result of the redevelopment shall be awarded so that such group of employees are a racially and ethnically-diverse group, all in accordance with applicable law.

VI. Project Financing

A. The City, either directly or through the Agency, shall establish and maintain the Fund, as required by applicable law. Both the City and the County shall deposit annually into the Fund an amount equal to 95 % of the increment from ad valorem taxes collected within the Redevelopment Area pursuant to Section 163.387 (1)(b), Florida Statutes, Ordinance No. 05-110 enacted by the Board on June 7, 2005 and other provisions of applicable law.

B. The City, either directly or through the Agency, shall develop and promulgate rules, regulations and criteria whereby the Fund may be promptly and effectively administered, including the establishment and the maintenance of books and records and adoption of procedures whereby the City may, either directly or through the Agency, expeditiously and without undue delay, utilize such funds in accordance with the Board approved budget for the Redevelopment Area.

C. The City, either directly or through the Agency, shall select financial and legal consultants as necessary to assist in the preparation of the tax increment financing plans. The City and the Agency shall encourage the participation of and utilize small and minority businesses, specifically with respect to bond counsel, underwriters' counsel and underwriting services, in the development of the Redevelopment Area.

104 (d) of the Housing and Community Development Act of 1974, and as such may be amended. The City, and or Agency, may contract with County agencies to assist in residential relocation.

B. The City, either directly or through the Agency, shall cause an annual report of activities for the preceding fiscal year, which report shall include a complete financial statement setting forth its assets, liabilities, income and operating expenses as of the end of such fiscal year to be filed with the County on, or before March 31 of each year. Also, the City, either directly, or through the agency, shall cause an independent audit by a Certified Public Accounting firm to be performed on an annual basis, a copy of which is to be forwarded to the Board by the first of March of the following year. The preceding requirements must conform, or be compliant with, Sections 163.356 (c), and 163.387 (8) Florida Statutes and any reporting request subsequently made by the Controller General of the State of Florida.

C. All redevelopment activities conducted with respect to the Redevelopment Area shall be in conformance with the Plan as the same may be amended. Any amendments to the Plan as required by Section 163.361, Florida Statutes, must have prior approval of the Board before the City, either directly or through the Agency, may implement the change contemplated by the amendments. Once approved, however, the City, either directly or through the Agency, may implement the amendments thereto.

D. The City or the Agency, as the case may be shall include language in any loan agreement, grant agreement or other agreements or contracts entered into between the City or the Agency and business involved in the redevelopment effort of the Redevelopment Area which states that, as a condition to the business' receipt of monies or incentives from the City or the Agency, any new jobs created as a result of the redevelopment shall be awarded so that such group of employees are a racially and ethnically-diverse group, all in accordance with applicable law.

VI. Project Financing

A. The City, either directly or through the Agency, shall establish and maintain the Fund, as required by applicable law. Both the City and the County shall deposit annually into the Fund an amount equal to 95 % of the increment from ad valorem taxes collected within the Redevelopment Area pursuant to Section 163.387 (1)(b), Florida Statutes, Ordinance No. 05-110 enacted by the Board on June 7, 2005 and other provisions of applicable law.

B. The City, either directly or through the Agency, shall develop and promulgate rules, regulations and criteria whereby the Fund may be promptly and effectively administered, including the establishment and the maintenance of books and records and adoption of procedures whereby the City may, either directly or through the Agency, expeditiously and without undue delay, utilize such funds in accordance with the Board approved budget for the Redevelopment Area.

C. The City, either directly or through the Agency, shall select financial and legal consultants as necessary to assist in the preparation of the tax increment financing plans. The City and the Agency shall encourage the participation of and utilize small and minority businesses, specifically with respect to bond counsel, underwriters' counsel and underwriting services, in the development of the Redevelopment Area.

D. The City, either directly or through the Agency, after County approval may sell bonds and execute notes and other forms of indebtedness, as well as collateral documents, to finance capital improvements, land acquisition, or developer incentive programs deemed necessary for the Redevelopment Area; however, County approval as to amount, duration and purpose of such bonds, notes or other indebtedness, including advances pledging or obligating tax increment revenues, must be obtained prior to issuance of any such bond, note or other form of indebtedness including advances pledging or obligating tax increment revenues. The County's obligation to annually appropriate to the Fund shall continue until all loans, advances a indebtedness, if any, and interest thereon, of the Agency incurred as a result of redevelopment in the CRA, have been paid, or for as long as required by applicable law, whichever is later. In no year shall the County's obligation to the Fund exceed the amount of that year's tax increment as determined pursuant to Ordinance No 05-110. On the last day of the fiscal year of the Agency, any money which remains in the Fund after payment of expenses pursuant to Section 163.387(6), Florida Statutes, for such year shall be: (1) returned to each taxing which paid the increment in the proportion that the amount of the payment of such taxing authority bears to the total amount paid into the Fund by all taxing authorities within the Redevelopment Area for that year; (2) used to reduce the amount of any indebtedness to which increment revenues are pledged; (3) deposited into an escrow account for the purpose of later reducing any indebtedness to which increment revenues are pledged; or (4) appropriated to a specific redevelopment project pursuant to the approved Plan which project will be completed within three (3) years from the date of such appropriation.

E. The City voluntarily exempts The Children's Trust and the County Fire and Rescue District and from any contribution to the Community Redevelopment Trust Fund.

F. County approval of the Agency's annual budget is required prior to any expenditure by the Agency of any funds contributed by either the City or the County to its Community Redevelopment Trust Fund, excepting the payment of debt service payments to which the Agency has pledged its Tax Increment Financing revenues. Absent County approval of the annual budget all required Agency costs, excluding debt service, shall be funded through advances by the City and not from Tax Increment revenues deposited in the Community Redevelopment Trust Fund.

G. The City and the Agency hereby expressly agree that the delegation of powers to implement the Plan as approved by the Board pursuant to Resolution 661-05 is for a ten (10) year period. The City of North Miami Beach CRA shall continue to be delegated the powers to implement the Plan and shall receive Tax Increment Revenues from the County for no more than ten (10) years, unless either 1) within by the end of the fifth operating and fiscal year of the Agency, the County approves a Bond issue by the Agency, or an amendment to the Plan that further delineates purposes of, and demonstrates the need for long-term financing through bonds or notes that require a pledge of TIF revenues, or 2) by the end of the tenth year operating and fiscal year, absent a Bond issue, the County, upon the demonstration by the Agency that sufficient progress has been made towards the Agency's goals without having achieved its measurable goals, approves a progress report and plan update setting forth specific goals and strategies for a further period, and therewith an extension of the commitment of Tax Increment Revenues, for a period that shall not exceed ten (10) additional years. If (1) herein occurs, the delegation of powers to implement the Plan,

(the Plan, and the County's pledge of Tax Increment Revenues shall be extended for so long as bonds or notes referenced herein are outstanding, but in no event longer than for thirty (30) years from the date of this agreement.

VII. Citizen Participation

To carry out an effective and inclusive citizen participation process, the City, either directly or through the Agency, shall utilize community groups and seek community involvement and consider citizen input in the development of Redevelopment Area activities.

VIII. Project Management, Administration and Coordination

A. The City and/or the Agency shall cooperate with the County on any reasonable request of the County with respect to implementing any plan of action related to the Plan. The City and/or the Agency shall develop implementation schedules and timetables for all significant Redevelopment Area activities as determined by the City and/or the Agency copies of which shall be delivered to the Redevelopment Area Coordinator beginning one year from the implementation of this Agreement. The City and/or the Agency shall also deliver additional interim reports to the County upon request.

B. The Redevelopment Area Coordinator shall receive from the City and/or the Agency advance notice of all public meetings related to development of projects pursuant to this Agreement and on a regular basis, information regarding the progress of all such development through the design and construction of such projects.

C. During construction, the County shall have the right to attend all such public meetings and inspect the projects being developed at all reasonable times subject to reasonable restrictions imposed by the contractor.

D. The City and/or the Agency shall consult regularly with the Redevelopment Area Coordinator in order to keep the County reasonably informed throughout the duration of the planning, design and construction of such redevelopment projects. The City, either directly or through the Agency, shall be required to have an outside independent audit on the annual basis to monitor and investigate compliance with the terms of this Agreement. The right of the auditor to investigate, monitor, inspect, copy, review, verify and check operations and records of the City and the Agency shall include, but not be limited to, all of its employees, consultants, agents or authorized contractors and subcontractors, as well as, all administrative and operational facilities used by the City, the Agency and the County in connection with all matters arising under this Agreement. Records include, but are not limited to, construction, financial, correspondence, instructions, memoranda, bids and contract documents, as well as all other records pertaining to the planning, development and construction of projects pursuant to this Agreement. Any rights that the County has under this provision shall not be the basis for any liability to accrue to the County from the City, the Agency or third parties for such monitoring or investigation or for the Area, all in accordance with applicable law.

X. City Assurances Regarding Affirmative Action

As part of this Agreement the City and the Agency, as the case may be, shall follow applicable federal, State and County laws and regulations concerning affirmative action and race/ethnic/gender conscious concerns all in accordance with applicable law.

XI. Amendments

This Agreement may be amended only by a written agreement signed by the City, the Agency and the County.

XII. Indemnification and other

A. The City and Agency shall indemnify and hold harmless the County and its officers, employees, agents and instrumentalities from any and all liability, losses or damages, including attorneys' fees and costs of defense, which the County or its officers, employees, agents or instrumentalities may incur as a result of claims, demands, suits, causes of actions or proceedings of any kind or nature arising out of, relating to or resulting from the performance of this Agreement by the City and Agency or its employees, agents, servants, partners principals or subcontractors. The City and Agency shall pay all claims and losses in connection therewith and shall investigate and defend all claims, suits or actions of any kind or nature in the name of the County, where applicable, including appellate proceedings, and shall pay all costs, judgments, and attorney's fees which may be issued thereon. Provided, however, this indemnification shall only be to the extent and within the limitations of Section 768.28 Fla Stat., subject to the provisions of that Statute whereby the City and Agency shall not be held liable to pay a personal injury or property damage claim or judgment by any one person which exceeds the sum of \$100,000, or any claim or judgment or portions thereof, which, when totaled with all other claims or judgment pay by the City and Agency arising out of the same incident or occurrence, exceed the sum of \$200,000 from any and all personal injury or property damage claims, liabilities, losses or causes of action which may arise as a result of the negligence of the City and Agency.

B. Third Party Beneficiaries. None of the parties intend to directly or substantially benefit any third party by this Agreement. Therefore, the parties agree that there are no third party beneficiaries to this Agreement and that no third party shall be entitled to assert a claim against either of them based upon this Agreement.

C. All parties have substantially contributed to the drafting and negotiation of this Agreement and this Agreement shall not, solely as a matter of judicial construction, be construed more severely against one of the parties than any other. The parties hereto acknowledge that they have thoroughly read this Agreement, including all exhibits and attachments hereto, and have sought and received whatever competent advice and counsel was necessary for them to form a full and complete understanding of all rights and obligations herein.

D. Jurisdiction: This Agreement shall be interpreted and construed in accordance with and governed by the laws of the State of Florida. Venue for litigation concerning this Agreement shall be in Miami-Dade County, Florida.

E. Severance: Should any clause or provision of this Agreement be determined to be illegal, invalid or unenforceable under any present or future law by final judgment of a court of competent jurisdiction, the remainder of this Agreement will not be affected thereby. It is the intention of the parties that if any such provision is held to be illegal, invalid or unenforceable, there will be added in lieu thereof a legal, valid and enforceable provision that is as similar as possible in terms to the illegal, invalid or unenforceable provision, which is agreed to by all parties.

F. Waiver: No express or implied consent or waiver by a party to or of any breach or dealt by the other party in the performance by such other party of its obligations under this Agreement will be deemed or construed to be a consent or waiver to or of any other breach or dealt in the performance by such other party of the same or any other obligations of such other party hereunder. Failure by a party to complain of any act or failure to act of the other party or to declare the other party in default, irrespective of how long such failure continues will not constitute a waiver by such party of its rights hereunder. The giving of consent by a party in any one instance will not limit or waive the necessity to obtain such party's consent in any future instance.

IN WITNESS WHEREOF, the parties hereto have caused this Agreement to be executed in their names by their duly authorized officers and the corporate seals to be affixed hereto, all as of the day and year first above written.

WITNESS our hands and seals on this 17th day of Oct, 2005.

CITY OF NORTH MIAMI BEACH, FLORIDA,
A municipal corporation of the State of Florida

MIAMI-DADE COUNTY, FLORIDA,
a political subdivision of the State of Florida

By: [Signature]
City Manager

By: [Signature]
County Manager

ATTEST

By: [Signature]
City Clerk

By: [Signature]
Deputy Clerk

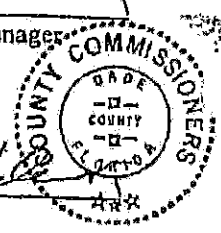

APPROVED AS TO FORM AND LEGAL SUFFICIENCY

APPROVED AS TO FORM AND LEGAL SUFFICIENCY

By: [Signature]
City Attorney

By: [Signature]
Assistant County Attorney

NORTH MIAMI BEACH COMMUNITY REDEVELOPMENT AGENCY,
a public body corporate and politic

By: [Signature]
Chairman

ATTEST:

By: [Signature]
Clerk

Appendix B - Legal Description

CITY OF NORTH MIAMI BEACH, FLORIDA
COMMUNITY REDEVELOPMENT AREA

Adopted 2005
Readopted 2016

Being a portion of Sections 7, 8, 9, 16, 17, and 18, Township 52 North, Range 42 East, all the following plats recorded in the Public Records of Miami-Dade County, Florida and being more particularly described as follows: Begin at the Intersection of the centerlines of S.R. #826 and of NE 8th Avenue as shown on Right-of-Way Map of said S.R. #826 Section No. 87510-2250, Sheet 4 of 5; thence Southerly along the centerline of said NE 8th Avenue for 963 feet, more or less, to the Westerly projection of the Southerly line of Tract "A" of CARL BYOIR SUBDIVISION as recorded in Plat Book 53, Page 29; thence Easterly along said Southerly line of Tract "A" for 1,287 feet, more or less, to the Westerly right-of-way line of NE 10th Avenue; thence Southerly along said Westerly right-of-way for 400 feet, more or less, to the Southerly right-of-way line of NE 163rd Street; thence Easterly along said Southerly right-of-way line for 671 feet, more or less, to the Westerly right-of-way line of NE 11th Avenue; thence Southerly along said Westerly right-of-way line for 225 feet, more or less; thence Easterly along the Southerly line of Lots 3 and 12, Block 14 of UNIT NO. 3 MONTICELLO PARK as recorded in Plat Book 44, Page 73, and its Westerly projection thereof for 230 feet, more or less, to the Westerly right-of-way line of NE 11th Court; thence Southerly along said Westerly right-of-way line for 75 feet, more or less; thence Easterly along the Southerly line of Lot 4, Block 15 OF UNIT NO. 3 MONTICELLO PARK and its Westerly and Easterly projection thereof for 320 feet, more or less, to the Westerly right-of-way line of NE 12th Avenue; thence Southerly along said Westerly right-of-way line for 175 feet, more or less, to the Westerly projection of the Southerly line of an alley between NE 161st Street and NE 162nd Street; thence Easterly along said Southerly line of alley for 1255 feet, more or less, to the Westerly right-of-way line of NE 14th Avenue; thence Southerly along said Westerly right-of-way for 180 feet, more or less, to the Southerly right-of-way line of NE 161st Street; thence Easterly along Southerly right-of-way line for 740 feet, more or less, to the Easterly right-of-way line of NE 15th Avenue; thence Northerly along said Easterly right-of-way line for 190 feet, more or less, to the Southerly line of an alley between NE 161st Street and NE 162nd Street; thence Easterly along said Southerly line for 580 feet, more or less, to the Westerly right-of-way line of NE 16th Avenue; thence Southerly along said Westerly right-of-way line for 190 feet, more or less, to the Southerly right-of-way line of NE 161st Street; thence Easterly along said Southerly right-of-way line for 740 feet, more or less, to the Easterly right-of-way line of NE 17th Avenue; thence Northerly along said Easterly right-of-way line for 320 feet, more or less, to the Southerly right-of-way line of NE 162nd Street; thence Easterly along said Southerly right-of-way line for 580 feet, more or less, to the Westerly right-of-way line of NE 18th Avenue; thence Southerly along said Westerly right-of-way line for 320 feet, more or less, to the Southerly right-of-way line of NE 161st Street; thence Easterly along said Southerly right-of-way line for 495 feet, more or less, to the Westerly right-of-way line of NE 18th Place; thence Southerly along said Westerly right-of-way line for 674 feet, more or less, to the Southerly right-of-way line of NE 159th Street; thence Easterly along said Southerly right-of-way line for 825 feet, more or less, to a point being the Northwesterly corner of Tract 'B' of PEOPLES GAS SUBDIVISION as recorded in Plat Book 142, Page 55; thence Southerly along the Westerly boundary line of said Tract 'B' for 638 feet, more or less; thence Westerly along the

Southerly line of Block 1 of FULFORD HOMES as recorded in Plat Book 55, Page 55, for 99 feet, more or less, to the Northwest corner of Tract 'C' of said PEOPLES GAS SUBDIVISION Plat; thence Southerly along the Westerly line of said Tract 'C' for 40 feet; thence Westerly for 50 feet, more or less, to the Easterly shoreline of a lake; thence Southerly for 85 feet, more or less, to the Northerly line of Aqua Bowl Park; thence Westerly along the Northerly boundary line of said park for 235 feet, more or less, to the Northwesterly corner of said park; thence Southerly along the Westerly boundary line of said park for 540 feet, more or less, to the Northeast corner of Block 1 of ECONOMY HOMESITES as recorded in Plat Book 44, Page 74; thence Southwesterly along the Northwesterly line of Lot 11 of said Block 1, and its Southwesterly projection line for 245 feet, more or less, to the Westerly right-of-way line of NE 19th Avenue; thence Southerly along said Westerly right-of-way line for 274 feet, more or less, to the Southwesterly right-of-way line of NE 154th Avenue; thence Southeasterly along said Southwesterly right-of-way line for 88 feet, more or less, to the Northwesterly right-of-way line of West Dixie Highway; thence Southwesterly along said Northwesterly right-of-way line for 90 feet, more or less; thence Southeasterly for 70 feet, more or less, to the Southeasterly right-of-way line of said West Dixie Highway; thence Northeasterly along said Southeasterly right-of-way line for 60 feet, more or less, to the Southerly right-of-way line of NE 154th Street; thence Easterly along said Southerly right-of-way line for 145 feet, more or less; thence Northerly for 70 feet to the Northerly right-of-way line of said NE 154th Street; thence Westerly along said Northerly right-of-way line for 75 feet, more or less, to the Southeasterly right-of-way line of said West Dixie Highway; thence Northeasterly along said Southeasterly right-of-way line for 1350 feet, more or less, to a point being the Northwesterly corner of Tract "A" of ADELE SUBDIVISION as recorded in Plat Book 126, Page 80; thence Easterly along the exterior Northerly line of said Tract "A" for 564 feet, more or less, to the Westerly right-of-way line of FEC Railroad; thence Northeasterly along said right-of-way line for 900 feet, more or less, to the Easterly projection of the Southerly right-of-way line of NE 159th Street; thence Easterly along said Easterly projection of the Southerly right-of-way line for 275 feet, more or less, to the Easterly right-of-way line of S.R. #5 as shown on Right-of-Way Map of said S.R. #5 Section 87030-2573, Sheet 3 of 7; thence Northeasterly along said Easterly right-of-way line for 400 feet, more or less, to the Northwesterly corner of Tract A of BELL GROVE TRACT as recorded in Plat Book 121, Page 37, the following three (3) courses being along the city limits of the City of North Miami Beach; (1) thence Westerly along the Westerly projection of the Northerly line of said Tract A for 125 feet, more or less, to the Westerly right-of-way line of said S.R. #5; (2) thence Northerly along said Westerly right-of-way line for 1,050 feet, more or less, to the centerline of S.R. #826 lying 50 feet South of the Northerly right-of-way line of said S.R. #826 as shown on said S.R. #5 Right-of-way Map; (3) thence Easterly along said centerline for 125 feet, more or less, to the Easterly right-of-way line of said S.R. #5; thence Northeasterly along said Easterly right-of-way line for 3,485 feet, more or less, to the Easterly projection of the Northerly line of the South 600 feet of Tract C of MAULE FEDERAL HIGHWAY INDUSTRIAL SITES as recorded in Plat Book 46, Page 55; thence Westerly along said Northerly line and its projection thereof for 340 feet, more or less, to the Westerly right-of-way line of said FEC Railroad; thence Northerly along said Westerly right-of-way line for 475 feet, more or less, to the Southeasterly projection of the Northeasterly line of Tract 1 of LEADER SUBDIVISION as recorded in Plat Book 82, Page 17, the following three (3) courses being along the exterior boundary line of said LEADER SUBDIVISION Plat; (1) thence Northwesterly the said Northeasterly line for 398 feet, more or less, to the Northeasterly corner of said Tract 1; thence Westerly along the Northerly line of said Tract 1 and also being the city limits of the City of North Miami Beach for 245 feet to the Northwesterly corner of said Tract 1; thence Southerly along the Westerly line of said Plat for 700 feet, more or less, to the centerline of NE 173rd Street; thence Southwesterly along the Westerly line of an alley which lies in between

77

Blocks 30 and 31 of FULFORD BY THE SEA SECTION "C" as recorded in Plat Book 25, Page 8, for 700 feet, more or less, to the Northerly right-of-way line of NE 171st Street; thence Westerly along said Northerly right-of-way line for 120 feet, more or less, to a point of intersection of the Northerly projection of the Westerly line of an alley which runs through Block 4 of GREYNOLDS PARK GARDENS as recorded in Plat Book 47, Page 32, the following two (2) courses being along said Westerly line of alley; (1) thence Southerly for 131 feet, more or less; (2) thence Southwesterly for 580 feet, more or less, to the Southwesterly right-of-way line of NE 170th Street; thence Southeasterly along said right-of-way line for 155 feet, more or less, to the Northwesterly right-of-way line of West Dixie Highway; thence Southwesterly along said Northwesterly right-of-way line for 810 feet, more or less, to the Easterly projection of the Northerly line of an alley which runs between NE 167th Street and NE 168th Street, and also being through Blocks 55 thru 57 of FULFORD BY THE SEA SECTION "D" as recorded in Plat Book 8, Page 58; thence Westerly along said Northerly line of alley for 1920 feet, more or less, to the Southwesterly corner of Lot 7 of said Block 57; thence Northerly for 330 feet, more or less, to the Northerly line of an alley which runs through Blocks 52 of said FULFORD BY THE SEA SECTION "D" Plat; thence Westerly along said Northerly line of alley for 156 feet, more or less, to the Easterly right-of-way line of NE 19th Avenue; thence Northerly along said Easterly right-of-way line for 425 feet, more or less; thence Westerly for 225 feet, more or less, to the Westerly line of an alley which runs through Block 46 of said Plat; thence Southerly along said Westerly line for 720 feet, more or less, to the Northwesterly right-of-way line of Miami Drive; thence Southwesterly along said right-of-way line for 570 feet, more or less, to the Westerly right-of-way line of NE 18th Avenue; thence Southerly along said Westerly right-of-way line for 275 feet, more or less, to the Northerly right-of-way line of Canal C-9, as shown on Canal's C-9 Right-of-Way Map; thence meander Westerly and Northwesterly along the Northerly and Northeasterly right-of-way line of Canal C-9 for 2700 feet, more or less, to the centerline of NE 15th Avenue; thence Southerly along said centerline for 2690 feet, more or less, to the centerline of S.R. #826, as shown on Right-of-Way Map of said S.R. #826 Section 87510-2250, Sheet 4 of 5; thence Westerly along said centerline for 1980 feet, more or less, to the centerline of NE 12th Avenue; thence Northerly along said centerline for 357 feet, more or less, to the Northerly right-of-way line of NE 164th Street; thence Westerly along said Northerly right-of-way line for 686 feet, more or less, to the Westerly right-of-way line of NE 11th Avenue; thence Southerly along said Westerly right-of-way line for 130 feet, more or less, to the Northerly right-of-way line of said S.R. #826 as shown on said Right-of-Way Map; thence Northwesterly along said Northerly right-of-way line for 770 feet, more or less, to the Easterly right-of-way line of NE 10th Avenue; thence Northerly along said Easterly right-of-way line for 660 feet, more or less, to the Northerly right-of-way line of NE 167th Street; thence Westerly along said Northerly right-of-way line for 366 feet, more or less, to the Southwesterly corner of Tract 'C' of NEWLAN SUBDIVISION as recorded in Plat Book 71, Page 98; thence Northerly along the Westerly line of said Plat for 438 feet to a point; thence Westerly for 166 feet, more or less, to the Northeasterly corner of Tract A of S. L. & S. SUBDIVISION as recorded in Plat Book 98, Page 38; thence Southerly along the Easterly line of said Plat for 313 feet, more or less, to the Southeasterly corner of said Tract A; thence Westerly along the Southerly line of said Tract A and its Westerly projection for 246 feet, more or less, to the Westerly right-of-way line of NE 9th Avenue; thence Southerly along said Westerly right-of-way line for 85 feet, more or less, to the Northerly right-of-way line of NE 167th Avenue, the following two (2) courses as shown on said Right-of-Way Map of S.R. #826; (1) thence Westerly along said Northerly right-of-way line for 635 feet, more or less, to the centerline of NE 8th Avenue; (2) thence Southerly along said centerline for 40 feet to the Point of Beginning.

Appendix C – Tax Increment Recapture Incentive Program

Program Description

The North Miami Beach Community Redevelopment Agency (the “CRA”) will use tax increment revenues to encourage economic development in the Community Redevelopment Area through this Tax Increment Incentive Program (the “TIF Recapture”).

The CRA is proposing to provide a TIF Recapture to the owner of a qualifying project. A qualifying project is one that is anticipated to create at least \$2 million in net new taxable value in the first full year following completion.

Provided that the real estate taxes levied on the property are paid prior to becoming delinquent and the owner complies at all times with any performance benchmarks referenced below, the TIF Recapture will be provided to owner on an annual basis through Fiscal Year 2027/28 (the “Recapture Period”) beginning on May 1 of the City’s Fiscal Year (FY) that commences after January 1 after a certificate of occupancy is issued for the project and the Miami-Dade County Property Appraiser assesses the value of the project.

The amount of the base TIF Recapture shall be 50% of the net new tax increment revenue generated by the project. If the taxable assessed value of the property (as determined by the Miami-Dade County Property Appraiser, taking into consideration any allowable adjustments by the Value Adjustment Board) in any year during the Recapture Period exceeds the base year value, the TIF Recapture shall equal 50% percentage of the project’s net new tax increment revenue.

The CRA Board of Commissioners may award additional TIF Recapture of up to 25% for projects that meet public policy goals, including:

- Inclusion of prioritized or targeted uses (i.e. grocery store, corporate headquarters, cultural institution);
- Job creation (a minimum number of jobs);
- Stimulative activities (inclusion of sidewalk café, minimum hours of operation);
- Other public benefits (open space, infrastructure improvements, transit-oriented development);

In any fiscal year, the TIF Recapture shall be subordinate in all respects to all CRA debt. At no time will the TIF Recapture exceed 75%.

Each project must demonstrate that the project would not be possible but for the incentive amount requested and must enter into an Economic Development Incentive Agreement with the CRA. The Agreement will include specific deadlines to retain the allocation for the TIF Recapture.

The incentives available through the TIF Recapture shall be available up until the earlier of either one of the following items occurs. The program will be reviewed by the CRA Board of Commissioners at the earlier of:

1. TIF Recapture for the first projects funded up to a total of \$200 million of taxable value;
or
2. 36 months from implementation of the incentive (October 16, 2017).

Program and Application Guidelines

Projects wishing to request a TIF Recapture must meet the following criteria:

- Project applicant must demonstrate property control either through ownership or contract for purchase;
- Applicants must submit a letter to the CRA requesting that the CRA Board of Commissioners consider providing incentive support to the project. The letter must include the following:
 - A copy of a conceptual site plan;
 - A description of the project including use, square footage, and density;
 - Names and qualifications of the principals and key representatives involved in the project. Special emphasis should be given to presenting past experience in public/private partnerships similar to the one that is being proposed;
 - Evidence of the financial strength of the deal to justify the risk of expending public capital, and demonstrated financial capacity of the principals. A lender commitment letter and letters of intent from end users of the proposed redevelopment property are helpful;
 - A defensible market study that demonstrates the high probability of success for the proposed project;
 - Any potential obstacles that the project may face in securing development approvals from the City with regard to the projects compliance with all applicable City, County and State building codes, as well as the City's Comprehensive Plan;
 - A project pro forma demonstrating the tax increment value anticipated by the project;
 - If applying for a 75% reservation of TIF Recapture, please provide an itemized list of public benefits to be provided by the project, per the attached criteria;
 - Any additional information that will assist the CRA Board during their decision-making process;
- Following receipt of a request for incentive support, CRA staff will schedule a kick-off meeting with the applicant to finalize the project information for submission to the RAB and CRA Board;
- Projects will first be reviewed by the Redevelopment Advisory Board (RAB) and then by the CRA Board;
- Award of TIF Recapture is conditioned on site plan approval within one year of award and building permit within two years. Applicants not meeting these conditions will lose any reservation of TIF Recapture, but may apply again if funding is still available.
- Grantees must comply with *Section 24.58, Assessments* under the MU/TC, MU/NC and MU/EC zoning categories of the City of North Miami Beach Code of Ordinances prior to receiving any tax increment rebate

Per the TIF Recapture Guidelines, projects that meet eligibility requirements and comply with Section 24-58, Assessments shall receive a 50% rebate of the net new taxable value created by a project over the base year as established at time of reservation. Projects can also be eligible for an additional 25% TIF Recapture public policy goals and specific criteria as follows:

Bonus Tax Increment Rebate Schedule and Requirements		
Incentive Option	Tax Increment Rebate	Requirement
Green Building	10% LEED Certified or equivalent 15% LEED Silver or equivalent 20% LEED Gold or equivalent 25% LEED Platinum or equivalent	Properties that obtain LEED or Equivalent Green Certification. Developers seeking this option shall incur all costs for certification and create an escrow/cost recovery account so that the City can retain the services of a Green Development Review Agent (GDRA). The developer will have to secure its certification prior to receipt of any tax increment rebates.
	15% Green Roof(s)	In no case shall the applicant receive a tax incentive for green roofs if the applicant is already providing a green roof as part of a LEED or equivalent Green Building certification. At least 75% of the roof space must be covered by the green roof and subject to the requirements as prescribed by the CRA
Public Streetscape and Infrastructure	15% Public Parking	A minimum of 10% above the required parking for the project shall be encumbered for public parking subject to the requirements of the CRA
	Up to 25% Infrastructure and Streetscape Improvements	Properties that provide substantial infrastructure upgrades that provide a benefit to more than one property and/or public streetscape improvements as reviewed by CRA and City staff shall be eligible for up to 25% depending on the level and cost of improvements.
	Up to 10% Public Art	Properties that incorporate public art visible and/or usable to the public may qualify for up to 10% tax incentives subject to review and approval of the CRA. The level of incentive will also be at the discretion of the CRA.
Parks and Open Space	15% Provision of public open space	Properties that develop and maintain a minimum of 4,800 square feet of public open space shall be eligible for a tax incentive. Public open space shall be usable and open to the public for a minimum of 12 hours per day and be constructed per the requirements of the CRA.

81

Appendix D – West Dixie Highway Implementation Strategy

Please see following pages.

West Dixie Highway Implementation Strategy

Report of Findings – Existing Conditions

Prepared for the North Miami Beach
Community Redevelopment Agency

Prepared by RMA, LLC - March 17, 2015

WEST DIXIE HIGHWAY IMPLEMENTATION STRATEGY

Report of Findings – Analysis of Conditions

Background

The purpose of this analysis is to identify short and long term improvements to the West Dixie Highway corridor to catalyze redevelopment. This report will provide the baseline inventory of existing and proposed land use, upcoming capital projects, existing infrastructure and potential for redevelopment. The project limits for this Implementation Strategy include the West Dixie Highway corridor from 163rd Street to 173rd Street and will also include the parcels directly adjacent to the West Dixie Highway Right of Way to the FEC railway.

The next step(s) to finalize this strategy include proposed meetings with adjacent property owners and businesses in order to develop recommendations for short and long term redevelopment. A recommended Implementation Strategy will be presented to the CRA Board in June 2015. In general, the West Dixie Highway corridor presents a more immediate opportunity for redevelopment given its City assets and planned capital projects.

Current Land Use Patterns

The West Dixie Highway corridor within the project limits has three distinct sub areas as follows:

1. 163rd Street to Snake Creek Canal Bridge - Commercial
2. Snake Creek Canal to 170th Street – Civic/Residential
3. 170th Street to 173rd Street – Neighborhood Commercial/Office

Area 1: 163rd Street to Snake Creek Canal

The area between 163rd Street and the Snake Creek Canal bridge is currently zoned for mixed use however redevelopment has been stalled in this area and there has been little redevelopment (with the exception of the NW corner of 163rd Street and West Dixie). The NE corner of 163rd Street and West Dixie Highway was developed in the 1990's prior to the current mixed use zoning.

The remaining parcels fronting West Dixie Highway, between 164th Street and the Snake Creek Canal were built in the 1950's when West Dixie Highway was still a two lane road. Currently a portion of the parking on the east side of the road encroaches on the right of way and there is limited sidewalk connectivity. The following diagram illustrates the existing roadway cross section.



West Dixie Highway looking South from Snake Creek Canal Bridge

FIGURE 1: WEST DIXIE HIGHWAY EXISTING CONDITIONS: NE 164TH STREET TO SNAKE CREEK CANAL

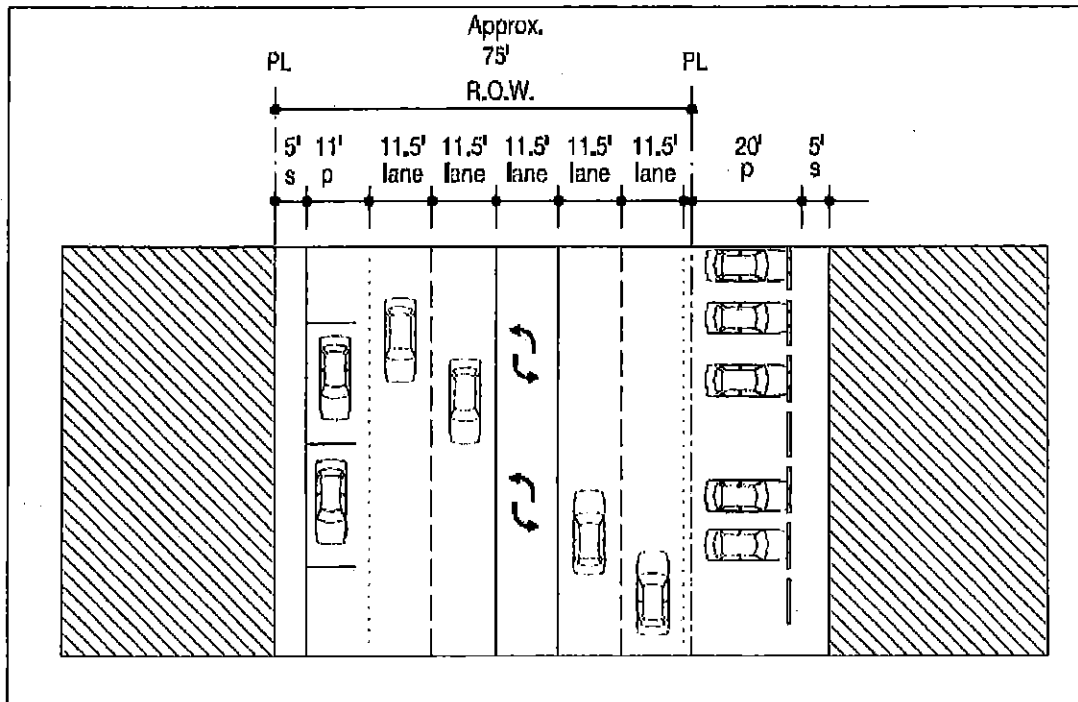

Area 2: Snake Creek Canal to 170th Street

The area between the Snake Creek Canal and 170th Street consists of a self contained residential condominium and the Spanish Monastery and North Miami Beach Tennis Center, both of which are local and regional destinations. The land use and zoning in these areas are not proposed to change, however there are opportunities to enhance the functionality of the two civic uses and recreational opportunities along the east side including construction of an urban greenway and potential expansion of the Snake Creek Canal greenway east of the Spanish Monastery creating a waterfront park at its terminus, which is part of the City Tennis Center. There is also a longer term future opportunity for private redevelopment of the Tennis Center site as well.



Spanish Monastery adjacent to Snake Creek Canal

85

Area 3: 170th to 173rd Street

The area between 170th and 173rd Street consists of neighborhood commercial uses such as restaurants, shops, office uses and neighborhood services. These uses seem to be well used by customers and employees however the buildings themselves are outdated, built in the 1960's and 1970's and the parking configurations are not functional.

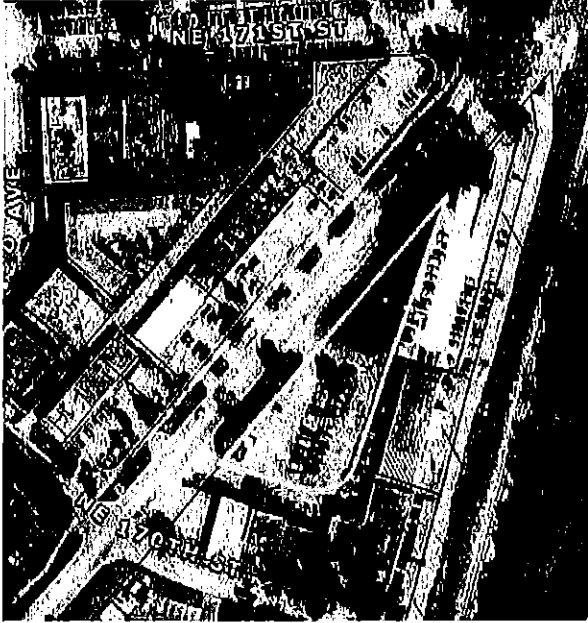

Neighborhood Commercial Area between 170 and 171 Street

On the east side of Dixie Highway, there is a City owned parking lot and City and County owned properties adjacent to the FEC railway to 173rd Street. On the west side of Dixie Highway the parcel depths are narrow and abut an alleyway that separates them from apartments, condominiums and a day care center. Lot depths for the commercial parcels range from approximately 115 to 125 feet. Furthermore, it appears from right of way maps, that the building adjacent to 170th Street be encroaching on the City's right of way and that some of the surface parking lots along Dixie Highway may be encroaching on County right of way. This will have to be further reviewed.

Proposed Land Use and Zoning

Mixed Use/Town Center (163rd Street to Snake Creek Canal)

The area between 163rd Street and the Snake Creek Canal will remain mixed use, however development standards will be changed to provide more development flexibility and encourage nearer term redevelopment. As such, the area surrounding West Dixie Highway is recommended as the "core" area of the Mixed Use Town Center (MU/TC) zoning category, which means this is planned for the most intense development. It is also the location of a proposed Transit stop, just to the east for the future commuter rail proposed for the FEC railroad. It is intended to be the most "active" and pedestrian oriented areas along the West Dixie Highway corridor based on the *Purpose and Intent* of the MU/TC zoning as follows:

"The intent is to enable transit-oriented development that contributes to the creation of an urban downtown and the formation of a quality pedestrian oriented, mixed-use district. The objective is to shape development to create a "place," an exciting, enlivened social gathering point and a destination that encourages the establishment of a wide mix of commercial and residential uses that offer the flexibility to meet a variety of market needs: The aim of these regulations is to create an environment that attracts day and

evening activities so that the street is occupied by visitors, residents, business owners and operators who have a clear and vested interest in the vitality of the Fulford Mixed-use Town Center District."

As redevelopment occurs the issues with parking and the lack of protected pedestrian areas and green space shall be resolved per the zoning requirements which have required setbacks, landscape and pedestrian access/urban greenway standards. However, in the near term there may be immediate impacts to the existing businesses, particularly related to parking with the proposed Snake Creek Canal Bridge project that will be discussed in a later section.

Mixed Use/Neighborhood Center (170th to 173rd Street)

The area between the Snake Creek Canal and 170th Street is not part of the proposed rezoning and shall remain Residential Medium Density (RM-23) on the west and Community Facility (CF) on the east. However there are certain public benefits prescribed by the mixed use zoning as well as the CRA's Tax Increment Recapture Program, such as an urban greenway and connectivity to the Snake Creek Canal that could be funded through private redevelopment within the MU/TC or MU/NC.

The area between 170th Street to 173rd Street is being rezoned to Mixed Use Neighborhood Center (MU/NC). It is intended to allow for mixed use development and commercial uses that serve the residents of the immediate area as well as the multi-family areas to the west based on the *Purpose and Intent* of the MU/NC zoning as follows:

"The intent is to support a balanced mix of land uses characterized by compactness, pedestrian friendly design, and neighborhood scale framed by architecture and landscape design appropriate to local history and the natural environment. Development patterns shall generally reflect planning and design principles such as walkable neighborhoods oriented around the five-minute walk, primary orientation towards public transit systems, a centrally located community-serving land use or land uses and greater integration of housing, employment, shopping and recreation at the neighborhood level."

The primary (near term) opportunity for redevelopment is on the east side of Dixie Highway adjacent to the FEC railway. Here, a larger scale mixed use development could occur through assembly of parcels. The City could have a direct impact in facilitating this kind of development by engaging in a public/private partnership that would include some of the City owned parcels in the assembly. This will be analyzed further as part of the overall Implementations Strategy.

The west side of Dixie Highway will most likely take longer for complete redevelopment as prescribed by the MC/NC zoning. However, there are short-term opportunities for redevelopment of the existing properties that will also be analyzed further as part of the overall Implementation Strategy.

A map of the West Dixie Highway Study Area and proposed zoning districts is depicted on the following page.

Infrastructure and Capital Improvements

West Dixie Highway Roadway and Bridge Improvements

As part of the *Miami Dade Metropolitan Planning Organization (MPO), Transportation Improvement Program, 2015* has funded Design and Engineering services for this fiscal year to widen West Dixie Highway from NE 164th Street to NE 173rd Street and widen and replace of the West Dixie Highway Bridge crossing the Snake Creek Canal. The overall scope of work includes design and construction drawings for both the bridge and roadway. Components of the bridge/roadway widening project include raised landscape medians (north of Snake Creek Canal), sidewalks, bicycle lanes, lighting, curb and gutter, a continuous storm water drainage system and intersection signalization improvements.

A Notice to Professional Consultants was issued on December, 30 2014 to solicit qualifications and select a firm to provide the overall master plan and construction drawings for the project in total. It is anticipated that the County will have a qualified Architectural/Engineering firm under contract by this June 2015. The Scope of Services also includes public involvement as part of the master planning process and potential right of way acquisition. While the design and engineering of this project will be completed simultaneously. Miami Dade County has allocated \$400,000 for design and construction services in FY 2014/2015.

As part of the "Draft" *Miami Dade Metropolitan Planning Organization (MPO), Transportation Improvement Program (TIP), 2016*, \$2,614,000.00 has been allocated to the replacement of the West Dixie Highway Bridge, which crosses the Snake Creek Canal for Fiscal Year 2015/2016. Funding for the roadway improvements has also been included in the *Draft MPO TIP, 2016* in the amount of \$8,500,000.00 over the next three years, and to be completed in FY 2017/2018.

From the preliminary summary of the project prepared by Miami Dade County, it is anticipated that the bridge replacement and widening will require some right of way acquisition. The areas identified in the preliminary report include 30 feet of right-of-way from the Snake Creek Canal to NE 167th Street, on the east side adjacent to the Spanish Monastery and 5 feet of right of way from NE 164th Street to NE 165th Street. However, the required R.O.W. at the Spanish Monastery may or may not be dependent on the final cross-section (2 or 4 lanes) north of the Snake Creek Canal.

The right of way between NE 164th Street and NE 165th Street would most likely come from the east side of West Dixie, adjacent to Lorenzo's Farmers Market (there is very little R.O.W. on the west side of Dixie adjacent to the Post Office), if so, it could impact the existing parking that backs out onto West Dixie Highway.

In terms of the roadway widening portion of the project from 164th Street to 173rd Street, this was added in 2012 at the request of the City of North Miami Beach. In 2010, the City of North Miami Beach hired URS to conduct a Traffic Impact Analysis of the West Dixie Highway corridor from NE 164th Street to NE 173rd Street. The results of the analysis were forwarded to Miami Dade County in February 2011 with a request to widen this portion of the road from two-lane with an exclusive turn lane to a four-lane median divided roadway with dedicated turn lanes.

The primary analysis, completed in 2010 was based on the projected future growth and roadway Level of Service (LOS) by 2035 within the overall Miami Dade Beach/CBD transportation planning area, which also includes the barriers Islands and the City of Miami.

The Operational Analysis conducted in 2010 concluded that existing condition LOS failure or approaching failure (E and F) were primarily located south of the Snake Creek Canal and along NE 172nd Street between US 1 and West Dixie Highway. The study indicated 2010 LOS between NE 164th Street and NE 172nd Street to be stable or free flowing (B and C). The posted speed limit for West Dixie Highway is 30 mph, which is fairly maintained in this area. The chart below summarizes the 2010 operational analysis:

2010 ARTERIAL ANALYSIS RESULTS FOR WEST DIXIE HIGHWAY ^I									
Arterial Segment	Result Type	AM Peak				PM Peak			
		SB		NB		SB		NB	
		Speed (MPH)	LOS	Speed (MPH)	LOS	Speed (MPH)	LOS	Speed (MPH)	LOS
West Dixie Highway	Total	13.7	E	15.4	D	14.4	D	15.3	D
US 1/West Dixie (172)	Segment	6.1	F	2.7	F	7.2	F	2.7	F
NE 172/NE 167 Street	Segment	24.1	B	28.4	B	23.5	C	28.4	B
NE 167/NE 164 Street	Segment	24.3	B	27.7	B	23.0	C	27.4	B
NE 164/NE 163 Street	Segment	4.0	F	21.5	C	4.4	F	19.4	C

The findings projected an increase of population and employment of 32 to 36% within the entire Beach/CBD transportation planning area by planning year 2035 and estimated roadway LOS increasing in some cases to failing as indicated in the table below. Within the segment

FUTURE YEAR 2035 ARTERIAL ANALYSIS RESULTS FOR WEST DIXIE HIGHWAY ^{II}					
Arterial/Segment	Result Type	SB		NB	
		Speed (MPH)	LOS	Speed (MPH)	LOS
West Dixie Highway	Total	7.9	F	11.9	E
US 1/West Dixie (172)	Segment	1.9	F	1.8	F
NE 172/NE 167 Street	Segment	11.6	E	28.4	B
NE 167/NE 164 Street	Segment	20.5	C	22.2	C
NE 164/NE 163 Street	Segment	4.5	F	17.1	D

between NE 164th Street and NE 172nd Street the major impacts to roadway capacity were projected to be southbound. However, it should be noted that the analysis conducted by URS was purely based on vehicular traffic and did not take into account mass transit or transportation alternatives in its modeling, including the future Tri Rail Coastal Link Station proposed at NE 164th Street. Furthermore due to the large planning area and the proposed changes to the land use and zoning, the 2010 models and projection may not be indicative of conditions if the analysis were conducted today. As part of the master planning process being conducted by Miami Dade County, the City or CRA may want to consider updating and/or conducting a more localized traffic impact analysis.

Intersections and Access Management

According to the URS Traffic Impact Analysis current levels of service at all signalized intersections within the study area, with the exception of NE 163rd Street and West Dixie Highway were above capacity with a LOS of A or B. However future modeling conducted for the study concluded that these LOS would deteriorate or in some cases fail based on projected 2035 traffic analysis.

In terms of pedestrian traffic at intersections, there were two intersections that were observed to be particularly dangerous for pedestrians. At the intersection of NE 164th Street and West Dixie Highway there is a lack of separation between the pedestrian areas and vehicles, particularly crossing West Dixie Highway. On the east side of Dixie Highway there is no protected landing area for a pedestrian crossing the street and the parking configuration backs out into the road. Due to this condition, there was also a lack of organization for vehicles observed either turning at the intersection or leaving adjacent parking areas. The intersection at NE 167th Street and West Dixie Highway was also observed to be highly dangerous, due to its configuration and lack of visibility at NE 22nd Avenue. The pedestrian crossings were not clearly marked and at NE 167th Street there was no pedestrian crossing signal.

Another issue analyzed by URS was access management utilizing restrictive medians in some areas. The study concluded that due to the already restricted right-of-way a median would be unlikely between NE 164th and 167th Streets. However there is an opportunity for a median from approximately NE 167th to 170th Street incorporating left turn lanes at the City Tennis Center. The area between NE 170th and 171st Street could present more challenges due to the number of curb cuts and already limited access to parking on the west side of West Dixie Highway. Specifically there are 7 curb cuts that lead to private parking for the businesses on the west side Dixie Highway and there is no cross access and limited internal circulation in these parking areas. Parking issues will be discussed further in this report, however, if there is not a concerted joint effort between these businesses, Miami Dade County and the City, there may be opposition to any kind of restrictive median in this area.

Recommended West Dixie Highway Cross Sections (per MU/NC and MU/TC Zoning Districts)

The proposed mixed use zoning for West Dixie Highway includes regulating plans for street networks, pedestrian areas and urban green but also recommends future roadway cross sections for West Dixie Highway which would be compatible with the future development regulations and create more pedestrian connectivity between districts.

Area 1: NE 163rd Street to the Snake Creek Canal

This area is proposed as a mixed use town center (MU/TC) area. The URS Traffic Analysis recommends a four lane cross section with dedicated turn lane; however the MU/TC zoning recommends a four lane median divided roadway to the north of NE 164th Street based on future redevelopment. Furthermore, the proposed cross section provides two options, one with on street parking and one without. These options should be further evaluated from a traffic perspective in terms West Dixie Highway master planning process. Figure 2 on the following page illustrates the two proposed options for consideration north of NE 164th Street to 167th Street.

Figure 2: West Dixie Highway Recommended Cross Section Options, south of Snake Creek Canal

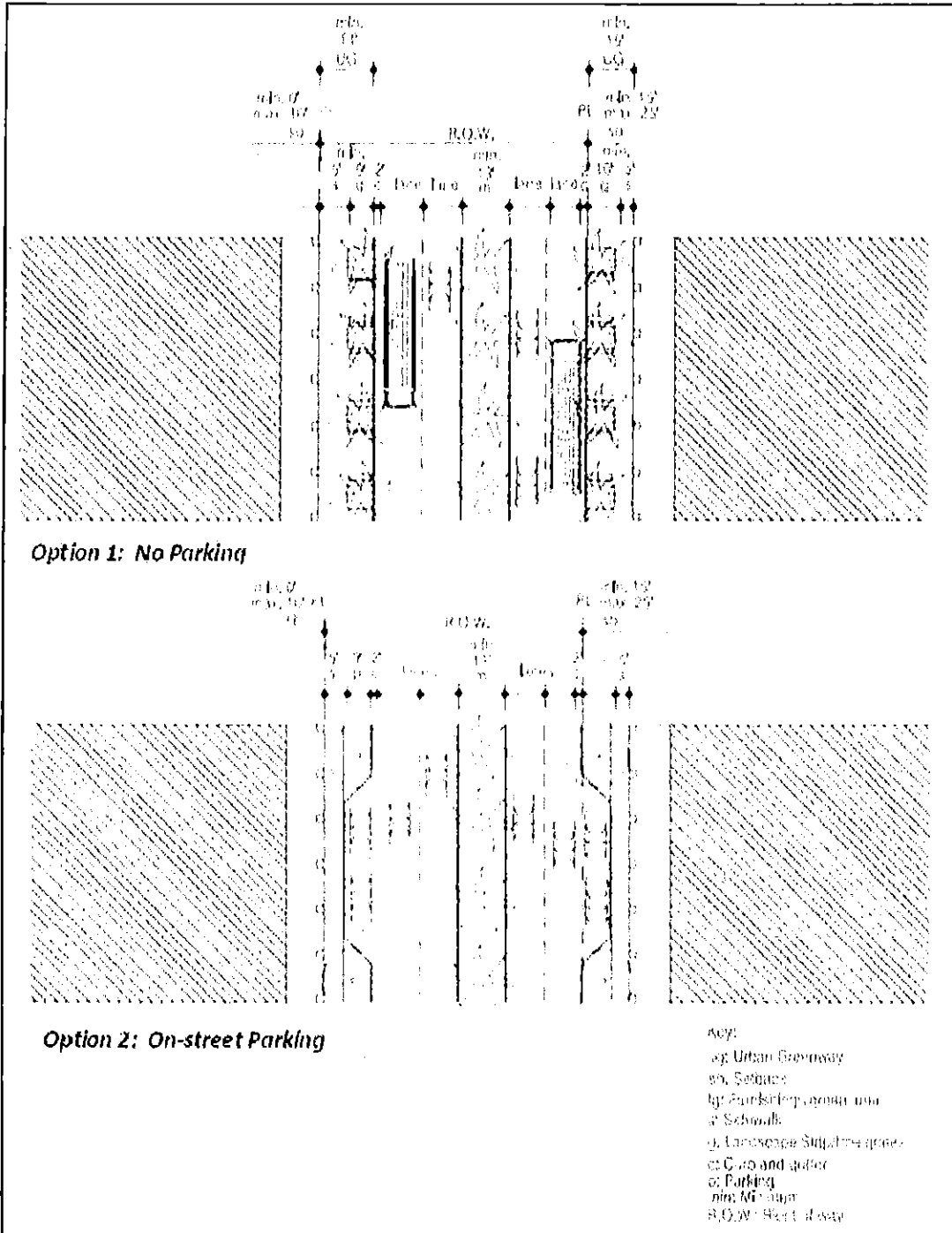

91

Area 2: North of the Snake Creek Canal to NE 170th Street

This area is not within the proposed mixed use rezoning and primarily consists of community facilities and a condominium which is outside of the CRA boundaries. As noted above the primary issues for this area are safety for both vehicles and pedestrians and the general operation of the intersection of NE 167th Street/22nd Avenue/West Dixie in order to improve safety. The URS Traffic Analysis recommended a four lane median divided cross section which extends north on West Dixie Highway, however the proposed zoning did not address a cross section for this area particular area, but does make recommendations just north of NE 170th which will be further discussed below.

Area 3: NE 170th Street to 172nd Street

This area is proposed to become a mixed use/neighborhood center. Due to much of the disorganization of the existing parking on the west side of the road and recommendations that this area become a neighborhood serving commercial/mixed use district, the proposed cross section for Dixie Highway is recommended as a two-lane divided with wide urban greenways and on street parking to support the businesses.

Figure 3: Proposed West Dixie Highway Cross Section, north of NE 170th

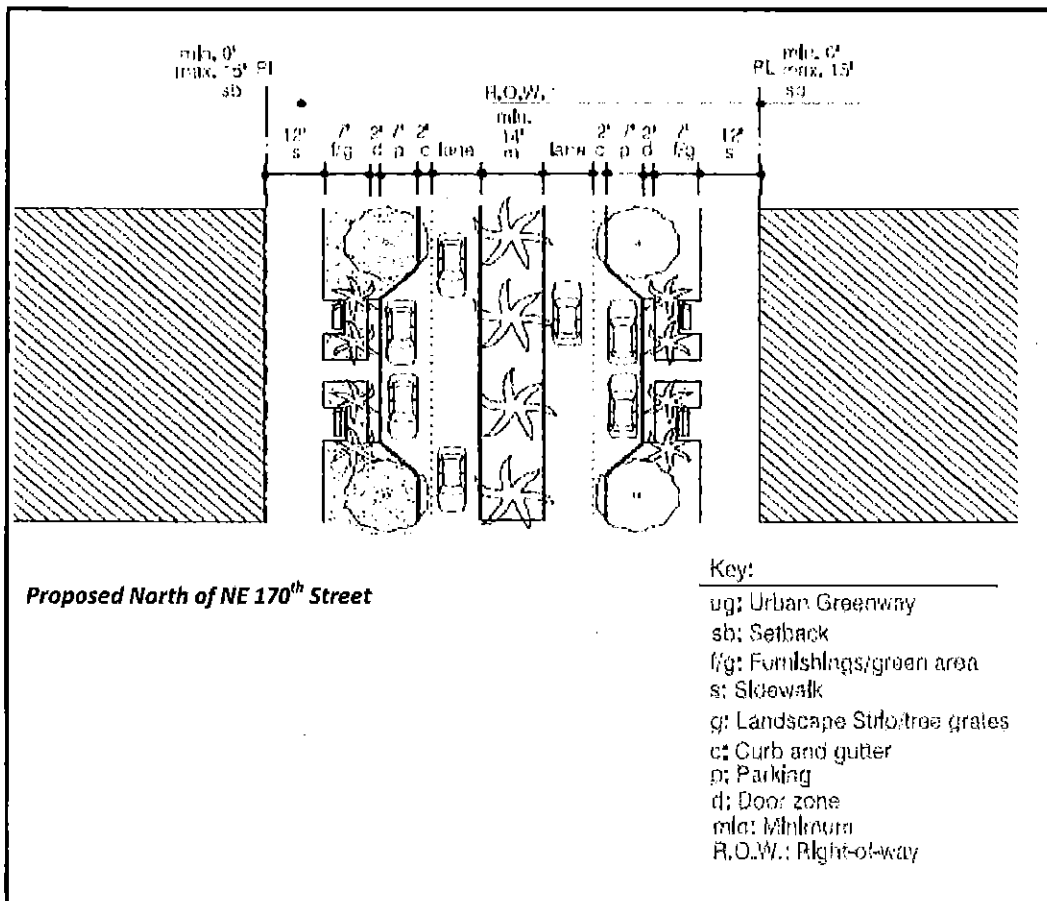

Sanitary Sewer

The West Dixie Highway corridor north of NE 163rd Street has availability for sanitary sewer connections and is serviced by Miami Dade County. However, there are approximately four parcels that are not connected, primarily on the west side of West Dixie Highway, but including the Tennis Center. The sewer main runs along West Dixie Highway and businesses will be required to connect as redevelopment occurs.

Parking

The City of North Miami Beach owns two parking lots along West Dixie Highway, one at the Tennis Center, the other on the east side of West Dixie Highway between NE 170th and 171st Street. The Tennis Center parking lot is shared by the Spanish Monastery. Currently the parking lot is in disrepair, primarily due to the large tree roots that have permeated some of the asphalt. This could pose a problem in terms of future renovations to the parking lot. During large scale events the parking overflows into neighboring areas.

The parking lot between NE 170th and 171st Street is approximately 1.39 acres and primarily serves the adjacent properties, with future redevelopment the City may consider leveraging the current parking lot as part of a public private partnership in exchange for providing additional parking to serve neighboring uses.

Assets

Parks, Open Space and Cultural Facilities

The Ancient Spanish Monastery, located north and adjacent to the Snake Creek Canal is a popular destination for tourists and venue for special events. It also is an operating church offering regular services on Sundays. The Spanish Monastery also sponsors a lecture series and outdoor concerts and offers an array of classes including yoga and chess.

Arthur I. Snyder Tennis Center located just north of the Snake Creek Canal provides tennis courts, paddleball courts and racquet ball courts in addition to passive green space. Offerings include tennis lessons, memberships and team play. The property actually runs to the south behind the Spanish Monastery terminating at the Snake Creek Canal. This portion of the property is currently underutilized and is hidden by the tennis courts, but could serve in the future as an extension to the Snake Creek trail or a waterfront park. Just to the north of the tennis center is a 25 foot wide linear parcel which is adjacent to the FEC right-of-way, and runs from NE 170th to 171st Street. It is currently used as an alleyway, but could potentially be incorporated into an urban greenway system. City owned parcels are depicted on the following map.

¹ Source: West Dixie Highway, Traffic Impact Analysis, December 2010, Prepared by URS (Table 5.1)

² Source: West Dixie Highways, Traffic Impact Analysis, December 2010, Prepared by URS (Table 5.3)

EXHIBIT B



STATE OF FLORIDA)
 COUNTY OF MIAMI-DADE) OFFICE OF THE CITY CLERK
 CITY OF NORTH MIAMI BEACH)

RECORDS CERTIFICATION
CITY OF NORTH MIAMI BEACH
CERTIFICATE OF AUTHENTICITY

I, Pamela L. Latimore, the duly appointed City Clerk of the City of North Miami Beach, and keeper of the records of the City of North Miami Beach, do hereby certify:

That the attached and foregoing is a true and correct copy of CRA Resolution No. R2016-2 consisting of three (3) page(s), and eighty-one (81) attached pages, as passed by Board of the North Miami Beach Community Redevelopment Agency on the twenty-eighth (28th) day of January, 2016, the original of which is now on file in the office of the City Clerk in the City of North Miami Beach, and, which said Resolution is still in full force and effect.

IN WITNESS WHEREOF, I have hereunto set my hand and affixed the official seal of the City of North Miami Beach, Florida this 6th day of April, A.D., 2016.

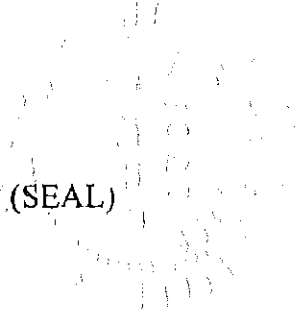

(SEAL)

PAMELA L. LATIMORE, CMC, CITY CLERK
CITY OF NORTH MIAMI BEACH

CRA RESOLUTION NO. R2016-2

A RESOLUTION OF THE CHAIRMAN AND BOARD MEMBERS OF THE NORTH MIAMI BEACH COMMUNITY REDEVELOPMENT AGENCY, FLORIDA; APPROVING THE 2015 AMENDED COMMUNITY REDEVELOPMENT PLAN; MAKING FINDINGS; DIRECTING STAFF TO ATTAIN THE REQUIRED APPROVALS; DIRECTING STAFF TO MAKE TECHNICAL, CONFORMING, AND CORRECTING CHANGES; PROVIDING AN EFFECTIVE DATE.

WHEREAS, the North Miami Beach Community Redevelopment Agency ("CRA") had prepared a 2015 Amended Community Redevelopment Plan ("2015 Plan Amendment") (attached hereto as Exhibit "A") in compliance with Chapter 163, Part III, Florida Statutes; and

WHEREAS, the City of North Miami Beach Planning and Zoning Board found the 2015 Plan Amendment consistent with the City's Comprehensive Plan at their January 11th, 2016 meeting with a 7 to 0 vote; and

WHEREAS, the City of North Miami Beach Redevelopment Advisory Board recommended approval of the 2015 Plan Amendment at their January 21st, 2016 meeting with a 6 to 0 vote; and

WHEREAS, the 2015 Plan Amendment will replace and supersede the existing Redevelopment Plan; and

WHEREAS, the 2015 Plan Amendment modifies, improves, and enhances the existing Redevelopment Plan; and

WHEREAS, the 2015 Plan Amendment does not extend the life of the CRA; and

WHEREAS, the 2015 Plan Amendment does not expand or alter the boundaries of the redevelopment area; and

WHEREAS, the 2015 Plan Amendment becomes enforceable and implementable only upon approval by the Miami-Dade County Board of County Commissioners as described in the October 11th, 2005, Interlocal Cooperation Agreement between Miami-Dade County, Florida, the City of North Miami Beach, Florida, and the North Miami Beach Community Redevelopment Agency.

CRA RESOLUTION NO. R2016-02

. . . 95

NOW, THEREFORE,

BE IT RESOLVED by the Chairman and Board Members of the City of North Miami Beach Community Redevelopment Agency, Florida.

Section 1. The Chairman and Board Members finds, declares, and determines that the matters set forth in the foregoing recitals are true and correct and incorporated herein as a part of the this resolution.

Section 2. The Chairman and Board Members hereby recommend for approval the 2015 Plan Amendment.

Section 3. The CRA Executive Director is directed to forward the 2015 Plan Amendment to the City Council of the City of North Miami Beach, Florida, for approval, following which the CRA Executive Director is directed to forward the approved plan to Miami-Dade County for its review and approval.

Section 4. The CRA Executive Director is directed to implement the 2015 Plan Amendment after final approval by Miami-Dade County.

Section 5. The Chairman and Board Members does hereby authorize appropriate City and CRA officials to make such technical, conforming, and correcting changes to the 2015 Plan Amendment from time to time as may be identified that do not affect the substance of the 2015 Plan Amendment's goals, objectives, and policies.

Section 6. This Resolution shall take effect immediately upon approval by the Chairman and Board Members.

CRA RESOLUTION NO. R2016-02

96

PASSED AND ADOPTED by a 5 – 0 vote of the Board of the North Miami Beach Community Redevelopment Agency, this 28th day of January, 2016.

ATTEST:

NORTH MIAMI BEACH COMMUNITY
REDEVELOPMENT AGENCY

CITY CLERK

GEORGE VALLEJO, CHAIRMAN

For → PAMELA LATIMORE

APPROVED AS TO FORM:

 2/3/16
LEGAL

SPONSORED BY: ADMINISTRATION

Moved by: Commissioner Kramer

Seconded by: Commissioner Martell

Vote:

Chairman George Vallejo	(Yes)	(No)
Board Member Anthony F. DeFillipo	(Yes)	(No)
Board Member Barbara Kramer	(Yes)	(No)
Board Member Marlen Martell	(Yes)	(No)
Board Member Frantz Pierre	(Yes)	(No)
Board Member Phyllis S. Smith	(Yes)	(No)
Board Member Beth E. Spiegel	(Yes)	(No)

CRA RESOLUTION NO. R2016-02

RESOLUTION NO. R2016-7

A RESOLUTION OF THE MAYOR AND CITY COUNCIL OF THE CITY OF NORTH MIAMI BEACH, FLORIDA, APPROVING THE NORTH MIAMI BEACH COMMUNITY REDEVELOPMENT AGENCY 2015 AMENDED COMMUNITY REDEVELOPMENT PLAN ("2015 AMENDED CRA PLAN"); MAKING CERTAIN FINDINGS WITH RESPECT TO THE REDEVELOPMENT PLAN AND THE GEOGRAPHIC AREA; DIRECTING THE CITY MANAGER TO FORWARD THE 2015 AMENDED CRA PLAN TO THE MIAMI-DADE COUNTY GOVERNMENT PURSUANT TO THE PROVISIONS OF THE INTERLOCAL AGREEMENT BETWEEN MIAMI-DADE COUNTY AND THE CITY OF NORTH MIAMI BEACH, FLORIDA.

WHEREAS, the North Miami Beach Community Redevelopment Agency ("CRA") prepared a 2015 Amended CRA Plan (attached hereto as Exhibit "A") in compliance with Chapter 163, Part III, Florida Statutes; and

WHEREAS, at the January 11th, 2016 Planning and Zoning meeting, the North Miami Beach Planning and Zoning Board, with a 7 to 0 vote, found the 2015 Amended CRA Plan consistent with the City's Comprehensive Plan pursuant to Section 163.360(2)(a) and Section 163.360(4), *Florida Statutes*; and

WHEREAS, on January 21st, 2016, the City of North Miami Beach Redevelopment Advisory Board recommended approval of the 2015 Amended CRA Plan with a 6 to 0 vote; and

WHEREAS, on January 28th, 2016 the CRA Board of Commissioners approved the 2015 Amended CRA Plan; and

WHEREAS, the 2015 Amended CRA Plan that will replace and supersede the existing Redevelopment Plan, does not extend the life of the CRA, and does not expand or alter the boundaries of the redevelopment area; and

WHEREAS, in accordance with the requirements of Section 163.346, *Florida Statutes*, notice of the amendments to the CRA Plan was provided to each taxing authority which levies ad valorem taxes on taxable real property within the redevelopment area; and

WHEREAS, after a duly noticed public hearing, the Mayor and City Council find the 2015 Amended CRA Plan meets all criteria set forth in Chapter 163, Part III, *Florida Statutes*, and in the

RESOLUTION NO. R2016-7

Interlocal Cooperation Agreement with Miami-Dade County, the City of North Miami Beach and the CRA; and

WHEREAS, the Mayor and City Council approve the 2015 Amended CRA Plan and authorize staff to forward it to the Miami-Dade County Board of County Commissioners for final approval and adoption.

NOW, THEREFORE, BE IT RESOLVED by the City Council of the City of North Miami Beach, Florida:

Section 1. The foregoing recitals are true and correct.

Section 2. The Mayor and City Council hereby adopt and approve the 2015 Amended CRA Plan for the North Miami Beach Community Redevelopment Agency and authorize the City Manager to make such technical, conforming, and correcting changes to the 2015 Amended CRA Plan, from time to time, that do not substantively change, modify, or alter any goals, objectives, and policies.

Section 3. The City Manager is hereby directed to submit the 2015 Amended CRA Plan to Miami-Dade County Government for review and approval.

Section 4. This Resolution shall take effect upon approval of the City Council.

APPROVED AND ADOPTED by the City Council of the City of North Miami Beach, Florida at regular meeting assembled this 2nd day of February, 2016.

ATTEST:

PAMELA L. LATIMORE
CITY CLERK

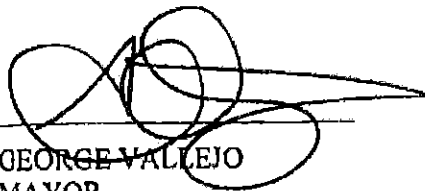
GEORGE VALLEJO
MAYOR

(CITY SEAL)

APPROVED AS TO FORM &
LANGUAGE & FOR EXECUTION

JOSE SMITH
CITY ATTORNEY

SPONSORED BY: Mayor and City Council

RESOLUTION NO. R2016-7