

Memorandum



Date: April 4, 2023

Agenda Item No. 8(N)(6)

To: Honorable Chairman Oliver G. Gilbert, III
and Members, Board of County Commissioners

From: Daniella Levine Cava
Mayor

A handwritten signature in blue ink that reads "Daniella Levine Cava".

Subject: Tri-Party Agreement between Miami-Dade County, the State of Florida Department of Transportation and CSX Transportation Inc. for the Installation of Railroad Crossing Traffic Control Devices at NW 107th Avenue in the Vicinity of NW 12th Street

Executive Summary

The purpose of this item is to gain approval of the Board of County Commissioners (Board) for execution of a Tri-Party Railroad Reimbursement Agreement between the County, the State of Florida Department of Transportation (FDOT), and CSX Transportation Inc. (CSX) for the installation of traffic control devices at a railroad crossing abutting District 12. The County will be responsible for the yearly maintenance fee for the railroad crossing traffic control devices in the amount of \$2,470 which is 50 percent of the total maintenance fee. CSX will cover the other 50 percent as stipulated by the cost sharing policy. CSX will install all the necessary signal safety upgrades to the grade crossing, and FDOT will pay for the installation costs.

Recommendation

It is recommended that the Board approve the attached resolution authorizing execution of a Tri-Party Agreement among the County, FDOT, and CSX for the installation of railroad crossing traffic control devices at NW 107th Avenue in the vicinity of NW 12th Street.

Scope

This Tri-Party Agreement is for one railroad crossing abutting District 12, represented by Commissioner Juan Carlos Bermudez, between the City of Doral and the City of Sweetwater.

Delegated Authority

Pursuant to Section 2-8.3 of the County Code, there are no delegations of authority beyond those specified in the attached resolution which authorize the County Mayor or County Mayor's designee to execute the Tri-Party Agreement on behalf of Miami-Dade County and to exercise the provisions contained therein.

Fiscal Impact/Funding Source

The County will be responsible for the yearly maintenance fee for the railroad crossing traffic control devices in the amount of \$2,470 which is 50 percent of the total maintenance fee. CSX will cover the other 50 percent as stipulated by the cost sharing policy. CSX will install all the necessary signal safety upgrades to the grade crossing, and FDOT will pay for the installation costs. The funding source to be used for the yearly maintenance fee is Secondary Gas Tax, programmed within the Fiscal Year 2022-23 Adopted Budget and Multi-Year Capital Plan,

Honorable Chairman Oliver G. Gilbert, III
and Members, Board of County Commissioners
Page No. 2

Volume 2, Program No. 2000000541, Countywide Safety Improvements, Railroad Crossing Improvements.

Track Record/Monitor

Javier M. Bustamante, Assistant Director, Department of Transportation and Public Works, will oversee and monitor this project.

Background

The yearly safety diagnostic review coordinated by FDOT revealed the need for improvements to the crossing traffic control devices at the railroad crossing. The applicable cost sharing policy was approved by the Board on October 5, 1976, under Resolution No. R-1090-76, which stipulates that the County assume 50 percent of the annual maintenance cost for devices on roadways maintained by Dade County.

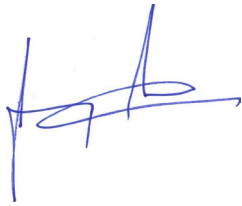

Jimmy Morales
Chief Operations Officer



MEMORANDUM
(Revised)

TO: Honorable Chairman Oliver G. Gilbert, III
and Members, Board of County Commissioners

DATE: April 4, 2023

FROM: 
Gen Bonzon-Keenan
County Attorney

SUBJECT: Agenda Item No. 8(N)(6)

Please note any items checked.

- "3-Day Rule" for committees applicable if raised
- 6 weeks required between first reading and public hearing
- 4 weeks notification to municipal officials required prior to public hearing
- Decreases revenues or increases expenditures without balancing budget
- Budget required
- Statement of fiscal impact required
- Statement of social equity required
- Ordinance creating a new board requires detailed County Mayor's report for public hearing
- No committee review
- Applicable legislation requires more than a majority vote (i.e., 2/3's present ____, 2/3 membership ____, 3/5's ____, unanimous ____, CDMP 7 vote requirement per 2-116.1(3)(h) or (4)(c) ____, CDMP 2/3 vote requirement per 2-116.1(3)(h) or (4)(c) ____, or CDMP 9 vote requirement per 2-116.1(4)(c)(2) ____) to approve
- Current information regarding funding source, index code and available balance, and available capacity (if debt is contemplated) required

Approved _____ Mayor
Veto _____
Override _____

Agenda Item No. 8(N)(6)
4-4-23

RESOLUTION NO. _____

RESOLUTION AUTHORIZING THE EXECUTION OF A TRI-PARTY AGREEMENT BETWEEN MIAMI-DADE COUNTY, THE STATE OF FLORIDA DEPARTMENT OF TRANSPORTATION AND CSX TRANSPORTATION INC. FOR THE INSTALLATION OF RAILROAD CROSSING TRAFFIC CONTROL DEVICES AT NW 107TH AVENUE IN THE VICINITY OF NW 12TH STREET WITH MIAMI-DADE COUNTY PAYING AN ANNUAL AMOUNT OF \$2,470.00 FOR MAINTENANCE OF THE RAILROAD CROSSING TRAFFIC CONTROL DEVICES; AND AUTHORIZING THE COUNTY MAYOR OR COUNTY MAYOR'S DESIGNEE TO EXECUTE SAME AND EXERCISE THE PROVISIONS CONTAINED THEREIN

WHEREAS, this Board desires to accomplish the purposes outlined in the accompanying memorandum, a copy of which is incorporated herein by reference,

NOW, THEREFORE, BE IT RESOLVED BY THE BOARD OF COUNTY COMMISSIONERS OF MIAMI-DADE COUNTY, FLORIDA, that this Board approves the execution of a Tri-Party Agreement between Miami-Dade County, the State of Florida Department of Transportation, and CSX Transportation, Inc. for the installation of railroad crossing traffic control devices at NW 107th Avenue in the vicinity of NW 12th Street with Miami-Dade County paying an annual amount of \$2,470.00 for maintenance of the railroad crossing traffic control devices, in substantially the form attached hereto and made a part hereof, and authorizes the County Mayor or County Mayor's designee to execute same on behalf of Miami-Dade County and to exercise the provisions contained therein.

The foregoing resolution was offered by Commissioner _____,
who moved its adoption. The motion was seconded by Commissioner _____
and upon being put to a vote, the vote was as follows:

Oliver G. Gilbert, III, Chairman	
Anthony Rodríguez, Vice Chairman	
Marleine Bastien	Juan Carlos Bermudez
Kevin Marino Cabrera	Sen. René García
Roberto J. Gonzalez	Keon Hardemon
Danielle Cohen Higgins	Eileen Higgins
Kionne L. McGhee	Raquel A. Regalado
Micky Steinberg	

The Chairperson thereupon declared this resolution duly passed and adopted this 4th day of April, 2023. This resolution shall become effective upon the earlier of (1) 10 days after the date of its adoption unless vetoed by the County Mayor, and if vetoed, shall become effective only upon an override by this Board, or (2) approval by the County Mayor of this resolution and the filing of this approval with the Clerk of the Board.

MIAMI-DADE COUNTY, FLORIDA
BY ITS BOARD OF
COUNTY COMMISSIONERS

LUIS G. MONTALDO, CLERK AD INTERIM

By: _____
Deputy Clerk

Approved by County Attorney as
to form and legal sufficiency.



Eduardo W. Gonzalez

STATE OF FLORIDA DEPARTMENT OF TRANSPORTATION
RAILROAD REIMBURSEMENT AGREEMENT
GRADE CROSSING TRAFFIC CONTROL DEVICES - COUNTY

FINANCIAL PROJECT NO	ROAD NAME OR NUMBER	COUNTY NAME	PARCEL & R/W NUMBER	FAP NUMBER
450046-1-57-01	NW 107 th Avenue	Miami-Dade	1(87000-SIGH)	TBD

THIS AGREEMENT, made and entered into this _____ day of _____, by and between the STATE OF FLORIDA DEPARTMENT OF TRANSPORTATION, hereinafter called the DEPARTMENT, and CSX TRANSPORTATION, INC. a corporation of VIRGINIA, with its principal place of business in the City of JACKSONVILLE, County of DUVAL, State of FLORIDA, hereinafter called the COMPANY; and MIAMI-DADE County, a political subdivision of the State of Florida acting by and through its Board of County Commissioners, hereinafter called the COUNTY

WITNESSETH:

WHEREAS, the DEPARTMENT is constructing, reconstructing or otherwise changing a portion of the Public Road System, designated by the Financial Project ID 450046-1-57-01, on NW 107th Avenue, which crosses at grade the right of way and tracks of the COMPANY'S Milepost SXL 45 52, FDOT/AAR Crossing Number 631075R, at or near the City of Doral, FL, as shown on DEPARTMENT'S Plan Sheet No. N/A, attached hereto as a part hereof; and

WHEREAS, the work contemplated hereunder is subject to the provisions of the Federal Highway Administration Federal-Aid Policy Guide, 23 C.F.R. Subchapter B, Part 140, Subpart I, as amended, and Federal-Aid Policy Guide, 23 C.F.R. Subchapter G, Part 646, Subpart B, as amended, and DEPARTMENT'S Rule 14-57.011 Florida Administrative Code, as amended; and

NOW, THEREFORE, in consideration of the mutual undertakings as herein set forth, the parties hereto agree as follows:

A. The COMPANY shall:

1. Install by its own forces, with supervision and approval of the DEPARTMENT, at an estimated cost of \$857,722.00, itemization of which is attached hereto, automatic railroad grade crossing traffic control devices hereinafter called "Devices", at said location, in accordance with (1) the attached detailed statement of the work plans and specifications; (2) the Standard Plans Index 509-070 and 711-001; (3) the FDOT Design Manual (FDM) and (4) Federal-Aid policy Guides mentioned above, or Rule 14-57.011, all of which are attached hereto and by reference made a part hereof.

2. Provide protective services in accordance with U.S. Department of Transportation Manual on Uniform Traffic Control Devices during the performance of the work, as indicated in the attached plans and specifications, the cost of which is included in the attached cost estimate.

3. Render the DEPARTMENT a final bill, in accordance with applicable Federal or State regulations, within one hundred eighty (180) days from the completion date of the project, for all actual reimbursable identified charges including credits for salvage or betterments, if any, attributable to the project; and itemize all substantial charges in a form comparable to the charges contained in the cost estimate.

4. Operate and maintain said devices and perform any adjustment, relocation or replacement of said devices; the cost therefore shall be assumed or apportioned in accordance with Paragraph C. below

B. The DEPARTMENT shall

1. Promptly reimburse the COMPANY for all actual costs attributable to the project as detailed in this agreement, pursuant to Paragraph A.1., as billed by the COMPANY, pursuant to Paragraph A.3

2. Payment shall be made only after receipt and approval of goods and services in accordance with Section 215.422(14), Florida Statutes.

C. The PARTIES agree:

1. That fifty percent (50%) of the cost for the operation and maintenance of the devices by the COMPANY shall be borne by the COUNTY and fifty percent (50%) shall be borne by the COMPANY, in accordance with the attached Schedule of Annual Cost of Automatic Highway Grade Crossing Traffic Control Devices, subject to future revision

2. That the cost of any adjustment, relocation or replacement of said devices shall be assumed by the party initiating such action, unless otherwise provided for in this contract, existing contracts between the parties, or in existing contracts between one of the parties and third party. Unless otherwise agreed upon herein, the COUNTY agrees to insure that at the crossing the advance warning signs and railroad crossing pavement markings will conform to the MUTCD within 30 days of notification that the railroad signal improvements have been completed and that such signs and pavement markings will be continually maintained at an acceptable level

3. ~~The COMPANY covenants and agrees that it will indemnify and hold harmless the DEPARTMENT and all of the DEPARTMENT'S officers, agents, and employees from any claim, loss, damage, cost charge, or expense arising out of any act, action, neglect, omission, or delay by the COMPANY during the performance of the contract, whether direct or indirect, and whether to any person or property to which the DEPARTMENT or said parties may be subject, except that neither the COMPANY nor any of its subcontractors will be liable under this section for damages arising out of injury or damage to persons or property directly caused or resulting from the sole negligence of the DEPARTMENT or any of its officers, agents, or employees.~~

FDOT

County

CSX

MDC007

4. That any provision contained in any existing contract relating to said crossing, whether between the parties hereto and/or third parties, shall be, and does, remain in full force and effect, except at otherwise provided herein

5. That the cost of maintaining any additional or replacement signal equipment at the same location will be shared as provided under Paragraph C 1. above

6. In accordance with Section 287.058, Florida Statutes, the following information is provided:

If this Contract involves units of deliverables, then such units must be received and accepted in writing by the Contract Manager prior to payments.

Bills for fees or other compensation for services or expenses shall be submitted in detail sufficient for a proper preaudit and postaudit thereof.

7. Bills for travel expenses specifically authorized in this Agreement shall be submitted and paid in accordance with DEPARTMENT Rule 14-57 011 "Public Railroad-Highway Grade Crossing Costs" and the Federal Highway Administration Federal-Aid Policy Guide Subchapter B, Part 140, Subpart I "Reimbursement for Railroad Work."

8. In accordance with Section 215.422, Florida Statutes, the following information is provided:

Contractors providing goods and services to the Department should be aware of the following time frames. Upon receipt, the Department has five (5) working days to inspect and approve the goods and services, unless the Agreement specifies otherwise. The Department has 20 days to deliver a request for payment (voucher) to the Department of Financial Services. The 20 days are measured from the latter of the date the invoice is received or the goods or services are received, inspected and approved.

If a payment is not available within 40 days, a separate interest penalty at a rate as established pursuant to Section 215.422(3)(b), Florida Statutes, will be due and payable, in addition to the invoice amount, to the Contractor. Interest penalties of less than one (1) dollar will not be enforced unless the Contractor requests payment. Invoices which have to be returned to a Contractor because of Contractor preparation errors will result in a delay in the payment. The invoice payment requirements do not start until a properly completed invoice is provided to the Department.

A Vendor Ombudsman has been established within the Department of Financial Services. The duties of this individual include acting as an advocate for contractors/vendors who may be experiencing problems in obtaining timely payment(s) from a state agency. The Vendor Ombudsman may be contacted at (850) 413-5516 or by calling the Division of Consumer Services at 1-877-693-5236.

9. In accordance Section 287.133 (2)(a), Florida Statutes, the following provisions are included in this Agreement

A person or affiliate who has been placed on the convicted vendor list following a conviction for a public entity crime may not submit a bid, proposal, or reply on a contract to provide any goods or services to a public entity; may not submit a bid, proposal, or reply on a contract with a public entity for the construction or repair of a public building or public work; may not submit bids, proposals, or replies on leases of real property to a public entity; may not be awarded or perform work as a contractor, supplier, subcontractor, or consultant under a contract with any public entity; and may not transact business with any public entity in excess of the threshold amount provided in s.287.017 for CATEGORY TWO for a period of 36 months following the date of being placed on the convicted vendor list

10 In accordance with Section 287.134(2)(a), Florida Statutes, the following provisions are included in this agreement:

An entity or affiliate who has been placed on the discriminatory vendor list may not submit a bid, proposal, or reply on a contract to provide any goods or services to a public entity; may not submit a bid, proposal, or reply on a contract with a public entity for the construction or repair of a public building or public work; may not submit bids, proposals, or replies on leases of real property to a public entity; may not be awarded or perform work as a contractor, supplier, subcontractor, or consultant under a contract with any public entity; and may not transact business with any public entity.

11. The Department's obligation to pay under this contract is contingent upon an annual appropriation by the Florida Legislature, in accordance with Section 287.0582, Florida Statutes

12. The State of Florida's performance and obligation to pay under this Agreement is contingent upon an annual appropriation by the Legislature. In the event this Agreement is in excess of \$25,000 and has a term for a period of more than one year, the provisions of Section 339.135(6)(a), Florida Statutes, are hereby incorporated:

The Department, during any fiscal year, shall not expend money, incur and liability, or enter into any contract which, by its terms involves the expenditure of money in excess of the amounts budgeted as available for expenditure during such fiscal year. Any contract, verbal or written, made in violation of this subsection is null and void, and no money may be paid on such contract. The Department shall require a statement from the Comptroller of the Department that funds are available prior to entering into any such contract or other binding

commitment of funds. Nothing herein contained shall prevent the making of contracts for periods exceeding 1 year, but any contract so made shall be executory only for the value of the service to be rendered or agreed to be paid for in succeeding fiscal years, and this paragraph shall be incorporated verbatim in all contracts of the department which are for any amount in excess of 25,000 dollars and which have a term for a period of more than 1 year.

13. It is understood and agreed that this agreement shall not be binding until it has been authorized or ratified by a proper ordinance or resolution of the County Commission of the COUNTY of MIAMI-DADE, Florida, a certified copy of which ordinance or resolution is attached hereto and made a part hereof.

14. The COMPANY shall

1. utilize the U.S. Department of Homeland Security's E-Verify system to verify the employment eligibility of all new employees hired by the COMPANY during the term of the contract; and

2. expressly require any subcontractors performing work or providing services pursuant to the state contract to likewise utilize the U.S. Department of Homeland Security's E-Verify system to verify the employment eligibility of all new employees hired by the subcontractor during the contract term

3. use steel and iron manufactured in the United States, in accordance with the Buy America provisions of 23 CFR 635.410, as amended. Ensure that all manufacturing processes for this material occur in the United States. As used in this specification, a manufacturing process is any process that modifies the chemical content, physical shape or size, or final finish of a product, beginning with the initial melting and continuing through the final shaping and coating. If a steel or iron product is taken outside the United States for any manufacturing process, it becomes foreign source material. When using steel or iron materials as a component of any manufactured product (e.g., concrete pipe, prestressed beams, corrugated steel pipe, etc.), these same provisions apply. Foreign steel and iron may be used when the total actual cost of such foreign materials does not exceed 0.1% of the total Contract amount or \$2,500, whichever is greater. These requirements are applicable to all steel and iron materials incorporated into the finished work but are not applicable to steel and iron items that the COMPANY uses but does not incorporate into the finished work. Submit a certification from the manufacturer of steel or iron, or any product containing steel or iron, stating that all steel or iron furnished or incorporated into the furnished product was produced and manufactured in the United States or a statement that the product was produced within the United States except for minimal quantities of foreign steel and iron valued at \$ (actual cost). Submit each such certification to the Engineer prior to incorporating the material or product into the project. Prior to the use of foreign steel or iron materials on a project, submit invoices to document the actual cost of such material, and obtain the Engineer's written approval prior to incorporating the material into the project; and

4. comply with all the requirements imposed by Title VI of the Civil Rights Act of 1964, the regulations of the U.S. Department of Transportation issued thereunder, and the assurance by the COMPANY pursuant thereto. The COMPANY shall include the attached Title VI / Nondiscrimination Assurance in all contracts with consultants and contractors performing work on the Project that ensure compliance with Title VI of the Civil Rights Act of 1964, 49 C.F.R. Part 21, and related statutes and regulations.

15. It is understood and agreed by the parties to this Agreement that if any part, term, or provision of this Agreement is held illegal by the courts or in conflict with any law of the State of Florida, the validity of the remaining portions or provisions shall not be affected, and the rights and obligations of the parties shall be construed and enforced as if the Agreement did not contain the particular part, term, or provision held to be invalid.

16. Any questions or matters arising under this Agreement as to validity, construction, enforcement, performance, or otherwise, shall be determined in accordance with the laws of the State of Florida. Venue for any action arising out of or in any way related to this Agreement shall lie exclusively in a state court of appropriate jurisdiction in Leon County, Florida.

17. The parties agree to bear their own attorney's fees and costs with respect to this Agreement.

18. The parties agree that this Agreement is binding on the parties, their heirs-at-law, and their assigns and successors in interest as evidenced by their signatures and lawful executions below.

19. A modification or waiver of any of the provisions of this Agreement shall be effective only if made in writing and executed with the same formality as this Agreement.

IN WITNESS WHEREOF, the parties hereto have caused these presents to be executed by their duly authorized officers the day and year first above written.

STATE OF FLORIDA
DEPARTMENT OF TRANSPORTATION

BY: _____
(TITLE Director of Transportation Development)

CSX TRANSPORTATION, INC:

BY:  _____
AS ITS: _____

Edward D. Sparks II, PE
Chief Engineer
Bridges, Design & Construction

MIAMI-DADE _____ COUNTY, FLORIDA

BY: _____
(TITLE: _____)

Legal Review	Approved as to Funds Available	Approved as to FAPG Requirements
BY: Alicia Trujillo Attorney - DOT	BY: _____ Comptroller - DOT	BY: _____ FHWA
Date	Date	Date

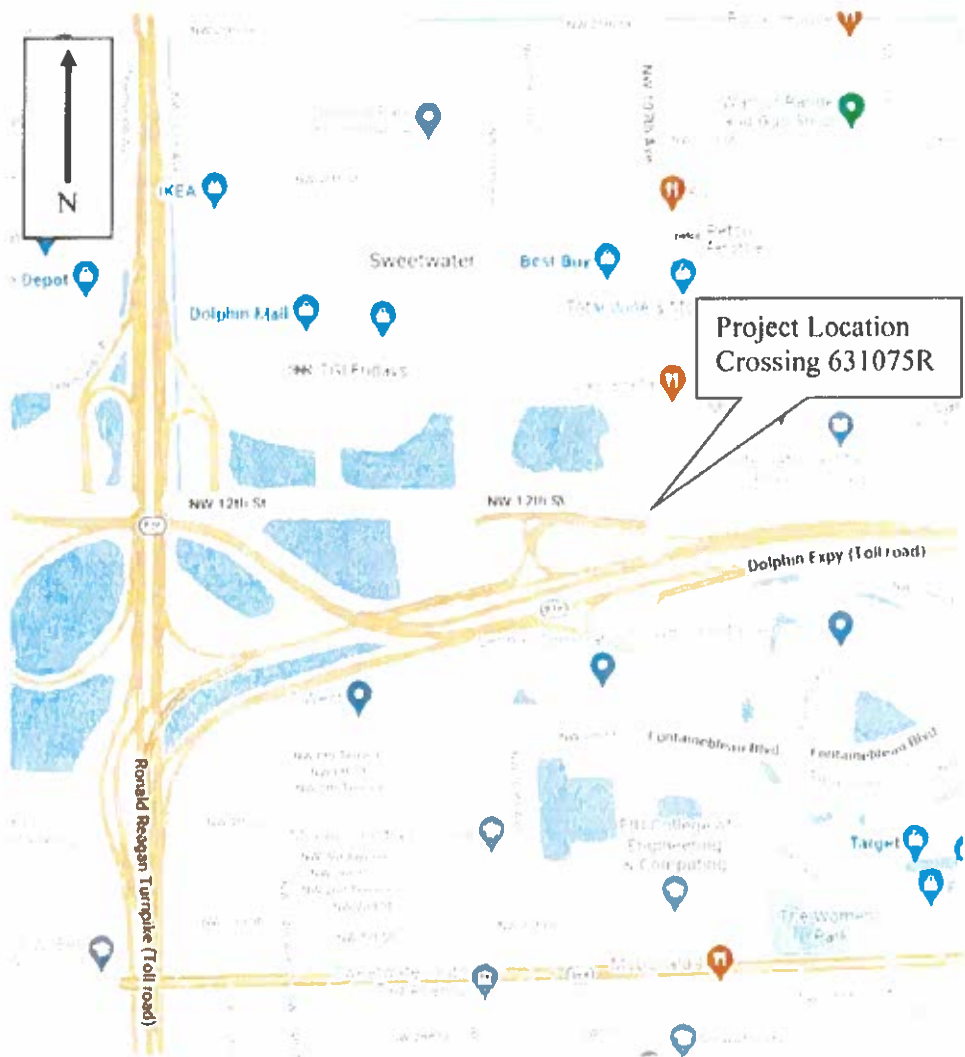

LOCATION MAP

CSX Transportation, Inc.

LOCATION:	NW 107 th Avenue
COUNTY:	Miami-Dade
FINANCIAL PROJECT NO.:	450046-1-57-01
CROSSING NO.:	631075R
RAILROAD MILEPOST:	SXL 45.52

WORK DESCRIPTION GRADE CROSSING TRAFFIC CONTROL DEVICES

FINANCIAL PROJECT NO.	ROAD NAME OR NUMBER	COUNTY NAME	PARCEL & R/W NUMBER	FAP NUMBER
450046-1-57-01	NW 107 th Avenue	MIAMI-DADE	1(87000-SIG11)	1(11)

RAIL ROAD COMPANY

CSX Transportation

- A JOB DESCRIPTION & LOCATION New 8' x 8' signal house, 2 full RR signal bridges, 2 median gate, 2 roadside gates, new power service, new pedestrian gates (NE and SW quadrants), train detection
- B TYPE OF ROADWAY FACILITY: 6 Thru lanes and 2 Turn Lanes - Urban Major Collector
- C FDOT/AAR XING NO. 631075R RR MILE POST TIE SXL 45.52
- D TYPE CROSSING PROPOSED IV Class III DOT INDEX: 509-070-1
- E STATUS AND PROPOSAL
- 1 EXISTING DEVICES (See Agreement dated NEW)
- a. None-New Crossing.
- b. Crossbuck and Disk
- c. Flashing Signals with Disk
- d. Flashing Signals with Cantilever
- e. Flashing Signals with Gates
- f. Flashing Signals with Cantilever and Gates
- 2 PROPOSED DEVICES (Safety Index Rating 1777)
- a. No revision required
- b. Crossbuck and Disk
- c. Flashing Signals and Disk
- d. Flashing Signals with Cantilever
- e. Flashing Signals with Gates
- f. Flashing Signals with Cantilever and Gates.
- g. Relocate existing signal devices
- (1) (With-Without) addition of Gates
- (2) ((With-Without) synchronization with highway traffic signals
- (3) ((With-Without) constant warning time
- F COMMUNICATION AND/OR POWER LINE ADJUSTMENTS
1. By Others (____ Company.)
2. By Railroad Company
- G. AUTHORITY REQUESTED (Draft attached Yes No)
1. Agreement (Third Party Participating MIAMI-DADE COUNTY)
2. Supplemental Agreement No. _____
3. Crossing Permit
4. Estimate for Change Order No. _____
5. Letter of Authority
6. Letter of confirmation (No Cost to Department)
- H OTHER REMARKS Negotiations to be completed by _____

Negotiations to be completed by _____

Signal installation target date _____

Synchronization: (Draft attached: Yes No)

RAILROAD REIMBURSEMENT AGREEMENT

FORCE ACCOUNT ESTIMATE

FINANCIAL PROJECT NUMBER	ROAD NAME OR NUMBER	COUNTY NAME	PARCEL & R/W #	Contract #	CROSSING #
450046-1-57-01	NW 107 th Avenue	MIAMI-DADE	1(87000-SIGH)	TBD	631075R

Tasks	FY	Cost
New 8' x 8' signal house, 2 full RR signal bridges, 2 median gate, 2 roadside gates, new power service, new pedestrian gates (NE and SW quadrants), train detection	2023	\$495,978.00
	2024	\$361,744.00
Total Cost		\$857,722.00

Prepared By:

**Hector Hartmann
Railroad Administrator
Florida Department of Transportation
1000 NW 111th Street
Miami, Florida 33172**

ESTIMATE SUBJECT TO REVISION AFTER: **2/28/2023** DOT NO.: 631075R
 CITY: Miami COUNTY: Miami-Dade STATE: FL
 DESCRIPTION: Order of Magnitude Estimate - NW 107th Avenue - Installation of (2) roadway gates, (2) median gates,
 (2) pedestrian gates, (2) signal bridges, 8x10 house, meter service and train detection (GCP-4000)
 ZONE: Florida SUB-DIV: Homestead MILE POST: SXL-45.52
 AGENCY PROJECT NUMBER: FDOT - D6

PRELIMINARY ENGINEERING:

212	Contracted & Administrative Engineering Services	\$	6,500
	Subtotal	\$	6,500

CONSTRUCTION ENGINEERING/INSPECTION:

212	Contracted & Administrative Engineering Services	\$	6,500
	Subtotal	\$	6,500

FLAGGING SERVICE: (Contract Labor)

70	Labor (Conductor-Flagman)	0	Days @	\$ 350.00	\$
50	Labor (Foreman/Inspector)	0	Days @	\$ 504.00	\$
70	Additive	137.00%	(Transportation Department)		\$
50	Additive	160.00%	(Engineering Department)		\$
	Subtotal				\$

SIGNAL & COMMUNICATIONS WORK: \$ 646,786

TRACK WORK: \$ -

PROJECT SUBTOTAL: \$ 659,786

900 **CONTINGENCIES:** 30.00% \$ 197,936

PROJECT TOTAL: \$ 857,722

CURRENT AUTHORIZED BUDGET: \$ -

TOTAL SUPPLEMENT REQUESTED: \$ 857,722

DIVISION OF COST:

Agency	100.00%	\$ 857,722
Railroad	0.00%	\$ -

NOTE: Estimate is based on FULL CROSSING CLOSURE during work by Railroad Forces.

This estimate has been prepared based on site conditions, anticipated work duration periods, material prices, labor rates, manpower and resource availability, and other factors known as of the date prepared. The actual cost for CSXT work may differ based upon the agency's requirements, their contractor's work procedures, and/or other conditions that become apparent once construction commences or during the progress of the work.

Office of Chief Engineer Public Projects--Jacksonville, Florida

Estimated prepared by: C Powell

Approved by: KSW CSXT Public Project Group

DATE: 02/28/22 REVISED: 01/00/00 DATE: 03/04/22

ACCT. CODE : 709 - TBD
 Pub EB - FL E83 (FL)

Form Revision
 12/23/21

BUY AMERICA

ESTIMATE SUBJECT TO REVISION AFTER: **2/28/2023** DOT NO.: 631075R
 CITY: Miami COUNTY: Miami-Dade STATE: FL
 DESCRIPTION: Order of Magnitude Estimate - NW 107th Avenue - Installation of (2) roadway gates, (2) median gates, (2) pedestrian gates, (2) signal bridges, 8x10 house, meter service and train detection (GCP-4000)
 ZONE: Florida SUB-DIV: Homestead MILEPOST: SXL-45.52
 DRAWING NO.: _____ DRAWING DATE: _____
 AGENCY PROJECT NUMBER: FDOT - D6

PRELIMINARY ENGINEERING:

Contracted & Administrative Engineering Services	\$ 6,500
Subtotal	\$ 6,500

CONSTRUCTION ENGINEERING/INSPECTION:

Contracted & Administrative Engineering Services	\$ 6,500
Subtotal	\$ 6,500

FLAGGING SERVICE (Contract Labor)

Labor (Conductor-Flagman)	11	Days @	\$ 350.00	\$
Labor (Foreman/Inspector)	10	Days @	\$ 504.00	\$
Additive	137.00%	(Transportation Department)		\$
Additive	160.00%	(Engineering Department)		\$
Subtotal				\$ -

COMMUNICATIONS WORK:

Temporary (Details Attached)	\$
Permanent (Details Attached)	\$
Subtotal	\$ -

TRACK: LABOR

Traffic Control	11	MAN-HRS	\$ 42.00	\$
Remove Existing Crossing	11	MAN-HRS	\$ 42.00	\$
Renew Cross Ties	11	MAN-HRS	\$ 42.00	\$
Renew Rail	11	MAN-HRS	\$ 42.00	\$
Install OTM	11	MAN-HRS	\$ 42.00	\$
Install Field Welds	11	MAN-HRS	\$ 42.00	\$
Install Geo-Textile Fabric	11	MAN-HRS	\$ 42.00	\$
Install Sub-Drains	11	MAN-HRS	\$ 42.00	\$
Install Ballast	11	MAN-HRS	\$ 42.00	\$
Line and Surface	11	MAN-HRS	\$ 42.00	\$
Install Crossing Materials	11	MAN-HRS	\$ 42.00	\$
Install Bituminous Pavement	11	MAN-HRS	\$ 42.00	\$
_____	11	MAN-HRS	\$ 42.00	\$
_____	11	MAN-HRS	\$ 42.00	\$
Clean-Up	11	MAN-HRS	\$ 42.00	\$
Additive	160.00%			\$
Subtotal				\$ -

TRACK: MATERIAL

BUY AMERICA

Cross ties, Main Line	11	EA	\$ 44.00	\$
	11	EA	\$ -	\$
Cross-tie - Borate	11	EA	\$ 56.00	\$
Cross-ties, 10' Length	11	EA	\$ 55.00	\$
Tie plates	11	EA	\$ 10.51	\$

Rail, 136RE, New	Q	LF	\$ 21.00	\$
Misc OTM	Q	LOI	\$ -	\$
Geo-Textile Fabric	Q	RL	\$ 930.00	\$
Sub-Drains	Q	LF	\$ 8.00	\$
Ballast - Car load	Q	NT	\$ 12.00	\$
Ballast - Trucked in	Q	NT	\$ 45.00	\$
Field Welds	Q	EA	\$ 100.00	\$
	Q		\$ -	\$
	Q		\$ -	\$
Concrete Full Width	Q	TF	\$ 250.00	\$
Concrete/Rubber Xing (CSX)	Q	TF	\$ 200.00	\$
Rubber Crossing, Full Depth	Q	TF	\$ 325.00	\$
Timber/Asphalt Crossing (CSX Standard)	Q	TF	\$ 42.00	\$
Bituminous Material	Q	NT		\$
Sales Tax on Material			7.00%	\$
Material Handling			15.00%	\$
Subtotal				\$ -

CONTRACT:

Asphalt Paving (In Place)	Q	NT	\$ 165.00	\$
Disposal of Waste Materials	Q	TF	\$ 15.00	\$
Maintenance of Traffic	Q	DAY	\$ 350.00	\$
Subtotal				\$ -

EQUIPMENT RENTAL: CSX vehicle and equipment rental included in overhead percentage

Subtotal Use for extraordinary rental or unique Service Contract				\$ -
---	--	--	--	-------------

WORK TRAIN:

	Q	DAY	\$ 2,100.00	\$
Subtotal				\$ -

SALVAGE:

Rail	Q	NT	\$ 65.00	\$
OTM	Q	NT	\$ 75.00	\$
Subtotal				\$ -

SIGNAL WORK: BUY AMERICA

Material - Field & Consumables			\$	272,920
Material - Sales Tax			\$	21,537
Material - Shop			\$	34,747
Construction Labor			\$	85,500
Shop Labor			\$	6,375
RR Engineering, Preliminary			\$	5,993
RR Engineering, Construction			\$	12,825
Additives to Construction Labor			\$	136,800
Additives to Shop Labor			\$	10,200
Additives to Engineering			\$	
Equipment Expense			\$	-
Waste Management			\$	480
Contract Engineering			\$	23,250
Freight			\$	19,660
AC Power Service			\$	5,000
Salvage			\$	(1)
Other - VAC TRUCK / Shoring Boxes			\$	11,500
Subtotal			\$	646,786

PROJECT SUBTOTAL: **\$ 659,786**

CONTINGENCIES: 30.00% \$ 197,936

<u>PROJECT TOTAL:</u>	\$	857,722
<u>CURRENT AUTHORIZED BUDGET:</u>	\$	-
<u>TOTAL SUPPLEMENT REQUESTED:</u>	\$	857,722

DIVISION OF COST:

Agency	100.00%	\$	857,722
Railroad	0.00%	\$	
		<hr/>	

NOTE: Estimate is based on FULL CROSSING CLOSURE during work by Railroad Forces.

This estimate has been prepared based on site conditions, anticipated work duration periods, material prices, labor rates, manpower and resource availability, and other factors known as of the date prepared. The actual cost for CSXT work may differ based upon the agency's requirements, their contractor's work procedures, and/or other conditions that become apparent once construction commences or during the progress of the work.

December 22, 2021 - Office of Director - CSXT Public Projects, Jacksonville, Florida

Estimated prepared by:	C Powell	Approved by:	KSW	Project Manager - Public Projects
DATE:	02/28/22	REVISED:	DATE:	03/04/22

STATE OF FLORIDA DEPARTMENT OF TRANSPORTATION
RAILROAD GRADE CROSSING TRAFFIC CONTROL DEVICES
ANNUAL MAINTENANCE COSTS

/25-060 #1
RAIL
00/21

FINANCIAL PROJECT NO.	ROAD NAME OR NUMBER	COUNTY NAME	PARCEL & R/W NUMBER	FAP NUMBER
450046-1-57-01	NW 107th Avenue	Miami-Dade	I(87000-SIGH)	TBD

COMPANY NAME CSX Transportation, Inc.

A. FDOT/AAR XING NO: 631075R RR MILE POST TIE SXL 45.52

B. TYPE SIGNALS PROPOSED IV CLASS III DOT INDEX 509-070-1

**SCHEDULE OF ANNUAL COST OF AUTOMATIC
HIGHWAY GRADE CROSSING TRAFFIC CONTROL DEVICES**

Annual Maintenance Cost Exclusive of Installation

<u>CLASS</u>	<u>DESCRIPTION</u>	<u>COST*</u>
I	2-Quadrant Flashing Lights with One Track	\$2,608.00
II	2-Quadrant Flashing Lights with Multiple Tracks	\$3,451.00
III	2-Quadrant Flashing Lights and Gates with One Track	\$3,934.00
IV	2-Quadrant Flashing Lights and Gates with Multiple Tracks	\$4,940.00
V	3 or 4-Quadrant Flashing Lights and Gates with One Track	\$7,777.00
VI	3 or 4-Quadrant Flashing Lights and Gates with Multiple Tracks	\$9,759.00

AUTHORITY: FLORIDA ADMINISTRATIVE RULE 14-57.011
Public Railroad-Highway Grade Crossing Costs

EFFECTIVE DATE: July 22, 1982

GENERAL AUTHORITY: 334.044, F.S.

SPECIFIC LAW IMPLEMENTED: 335.141, F.S.

*This schedule will become effective July 1, 2021 and will be reviewed every 5 years and revised as appropriate based on the Consumer Price Index for all Urban Consumers published by the U.S. Department of Labor.

Crossing No: 631075R		Roadway: NW 107TH AVENUE		RR Street:		District: 6		County: Miami-Dade	
PUBLIC HWY		AT GRADE Commercial		City: Doral		NEAR CITY		OPEN-TRACK ACTIVE	
Rank 2018:	3485	SR No.:		RR Company:	CSX	Date:	08/25/2021		
Rank 2017:	3488	CR No.:		Division Name:	Jacksonville	Team Members:	Hector Hartmann (FDOT-D6), Tiffany Gehrke (FDOT-D6 ADA), Cristina Morales (FDOT-D6 Traffic Ops), Javier Hurtado (Gannet Fleming for FDOT-D6), Marco Incer (CHP for FDOT-D6), Scott Willis		
Rank 2016:		US No.:		Subdivision Name:	HOMESTEAD				
		Latitude:	25.782400	Branch Name:	SXL				
		Longitude:	-80.370000	RR Milepost:	45.52				
Field Review Comments: Antiquated Cantilever structures.									
Team Recommendations: New 8' x 8' house, 2 full RR signal bridges, 2 median gates, 2 roadside gates, new power service, pedestrian gates NE and SW quadrants.									
Highway Speed:	40			Train Speed Range:	5-10				
Crossing Angle:	60-90 DEG			Max Time Table Speed:	10				
AADT:	66000 (2020)			Day Thru/Switch:	0/0				
Percent Trucks:	10 (2020)			Night Thru/Switch:	0/0				
School Buses:	0 (2020)			Train Service:	Freight				
Street Types:				Passenger Count/Day:					
Thru Lanes:	6			Train Count Date:	01/01/2011				
Aux Lanes:	2			Main Tracks:	1				
Hazmat Route?	YES			Other Tracks:					
Emergency Services Route?	YES								
Emergency Notification Signs:	YES			Train Signals?	NO				
Crossbuck(4x4 post):	0			Train Signal Proximity:	NO				
Crossbuck Sign:	8			Train Detection:	Motion Detection				
Stop Sign:	0			Event Recorder?					
Yield Sign:				Number of Bells:	2				
Low Ground Clearance Signs:				Post Mounted Flashing Lights:	0				
Exempt Signs:	NO			Roadway Gate Count:	4				
Trespass Signs:				Pedestrian Gate Count:					
W10-1	2	R10-6a		W8-1		Gates:	2 Quad, Median Gates		
W10-2		R11-2		W10-8		Cantilevered Flashing Over Traffic:	4		
W10-3		R15-2P		W10-9		Cantilevered Flashing Not Over Traffic:	0		
W10-4		R15-6		W10-9P		Intersecting Roadway?	YES		
W10-11		R15-6a		W10-11a		Signalized?	YES		
W10-12		R15-7		W10-11b		Interconnection:	Not Interconnected		
R3-1a		R15-7a		W10-13P		Traffic Signals Controlling?			
R3-2a		R15-8		W10-14P		Preemption:			
R8-8		Pvt Crossing		W10-14aP		Does traffic queue across the tracks?	NO		
R8-9		Look Out		W10-15P		Traffic Pre-Signals?			
R8-10		R8-8 w/Beacon		Slow		8" Count:	0		
R8-10a		W3-1		W10-1w/Beacon		12" Count:	12		
R10-6		W3-3		LED Signs		LED Count:	0		
Surface Installment Date:				Install - Upgrade	--	Maintenance Responsibility:	COUNTY		
Surface Type:	CONCRETE			Roadway Paved:	YES	Tracks run down street?	NO		
Pvmt Mkt:				Sidewalks on Crossing Approach?	YES	Sidewalks Thru Crossing?	YES		
Surface Condition:	FAIR			Crossing illuminated?	YES	Commerical Power?	YES		
Approach:	A = Smooth			Alternative Power?	NO	Recommended Warning Device	CFI & G&P		
Vehicle Reaction:	B = Vibrating								
Driver Reaction:	B = Some drivers slow down								
Rail/Pad Movement:	B = Uneven								
Incident History:									

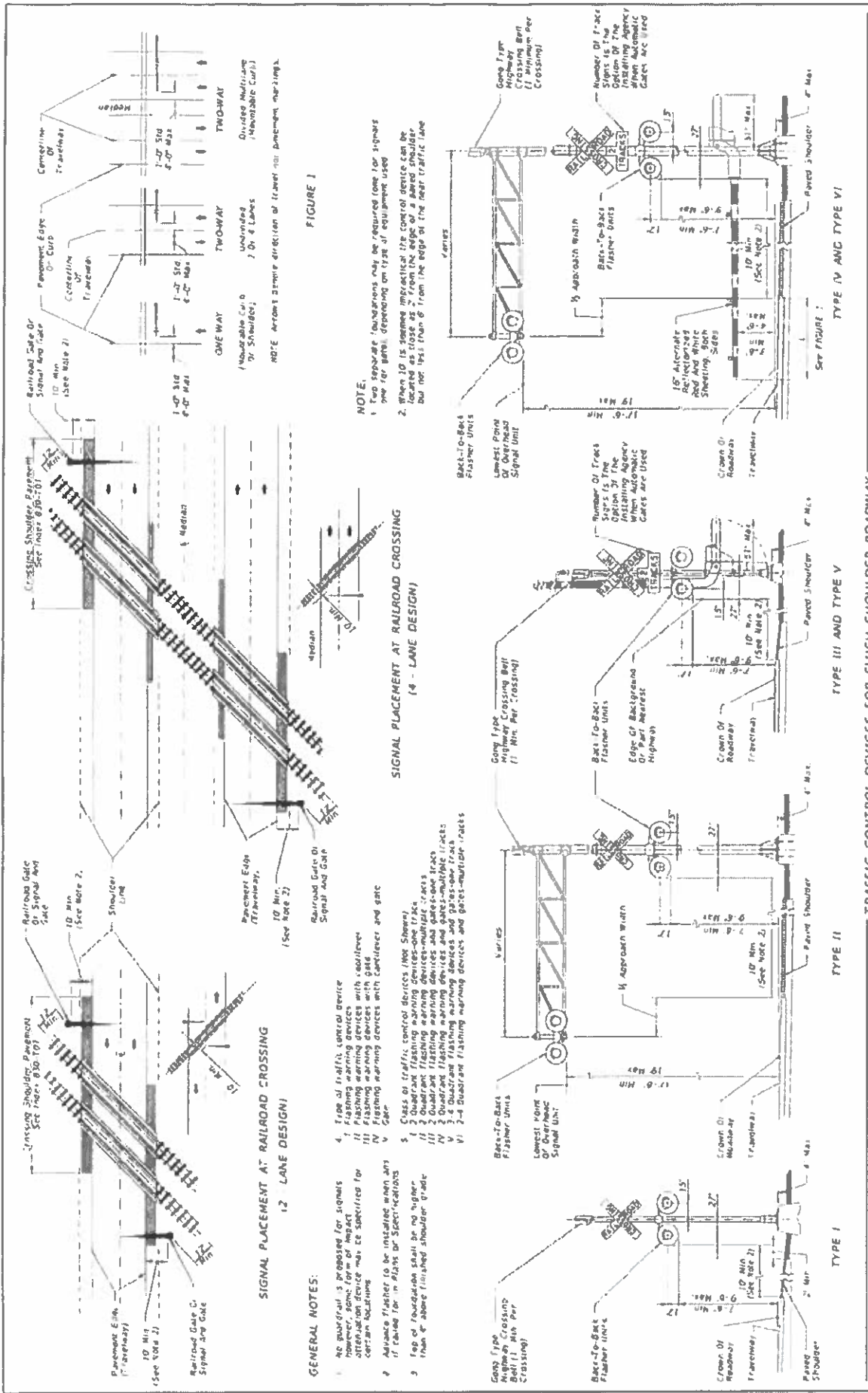

FIGURE 1

NOTE:
 1. Two separate foundations may be required (one for signals per rail, depending on type of equipment used)
 2. When 10 ft spacing (measured to the center of device) can be located as close as 2' from the edge of a paved shoulder but not less than 6' from the edge of the near traffic lane

SIGNAL PLACEMENT AT RAILROAD CROSSING (4 - LANE DESIGN)

- GENERAL NOTES:**
- No quadrant is proposed for signals; however, some form of impact attenuation device may be specified for certain locations.
 - Advance flasher to be installed when any track above finished shoulder grade.
 - Top of foundation shall be no higher than 6' above finished shoulder grade.
 - Class of traffic control devices (see below):
 I 1 - Flashing warning devices
 II 2 - Quadrant flashing warning devices and gates-multiple tracks
 III 3 - Quadrant flashing warning devices and gates-multiple tracks
 IV 4 - Quadrant flashing warning devices and gates-multiple tracks
 V 5 - Quadrant flashing warning devices and gates-multiple tracks
 VI 6 - Quadrant flashing warning devices and gates-multiple tracks

SIGNAL PLACEMENT AT RAILROAD CROSSING (1-2 LANE DESIGN)

SIGNAL PLACEMENT AT RAILROAD CROSSING (1-2 LANE DESIGN WITH SHOULDER)

SIGNAL PLACEMENT AT RAILROAD CROSSING (4 - LANE DESIGN WITH SHOULDER)

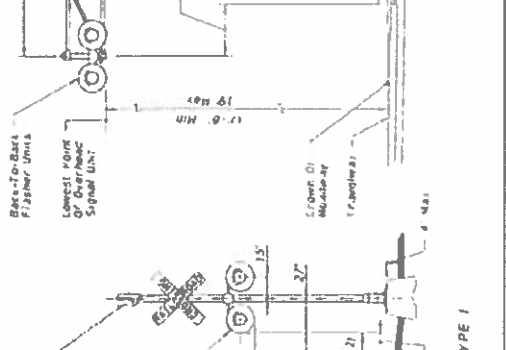
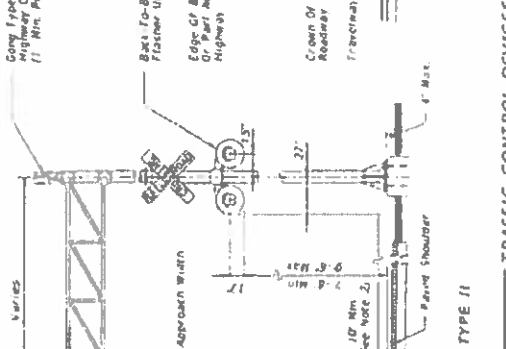
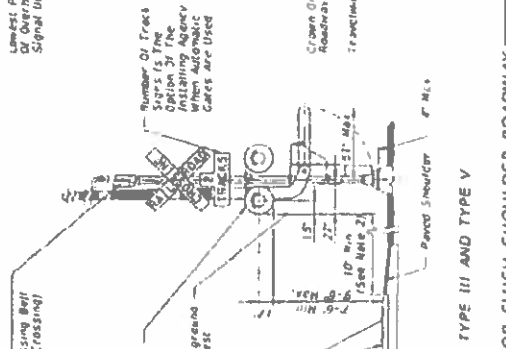
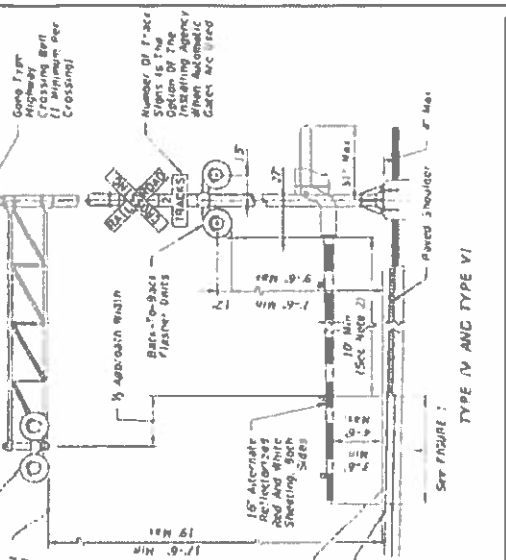

LAST REVISION 02/05/21	DESCRIPTION	STANDARD PLANS	INDEX 509-070	SHEET 1 of 3
FY 2022-23		RAILROAD GRADE CROSSING TRAFFIC CONTROL DEVICES		
FOOT		TRAFFIC CONTROL DEVICES FOR FLUSH SHOULDER ROADWAY		

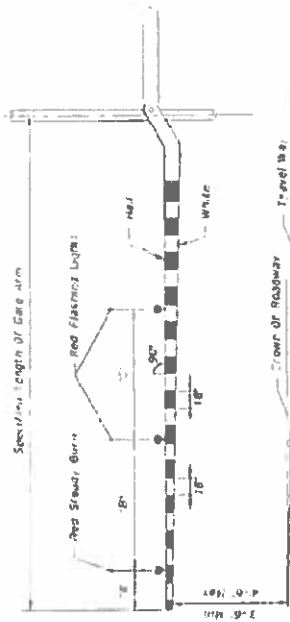

GATE ARM DETAIL

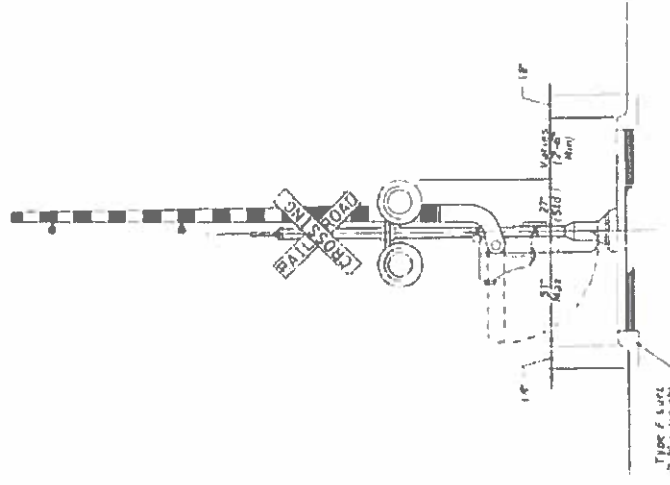

MEDIA SECTION AT SIGNAL GATES

MEDIA SIGNAL GATES FOR MULTILANE UNDIVIDED URBAN SECTIONS
(Type or More Driving Lanes in one Direction, 45 mph or less)

RELATIVE LOCATION OF CROSSING
TRAFFIC CONTROL DEVICES

RAILROAD GATE ARM LIGHT SPACING			
Specified Length Of Gate Arm	Dimension "A"	Dimension "B"	Dimension "C"
16 Ft	6"	36"	5'
15 Ft	18"	36"	5'
16-17 Ft	24"	36"	5'
18-19 Ft	28"	41"	5'
20-23 Ft	28"	5'	5'
24-28 Ft	28"	5'	5'
29-31 Ft	36"	6'	6'
32-34 Ft	36"	7'	7'
35-37 Ft	36"	9'	9'
38 and over	36"	10'	10'

NOTE:
For additional information, see the Manual of Uniform Traffic Control Devices, Part 8 The Traffic Control Member, Part VIII, and Article 14 Part 1 on Geometric Design of Streets and Highways.

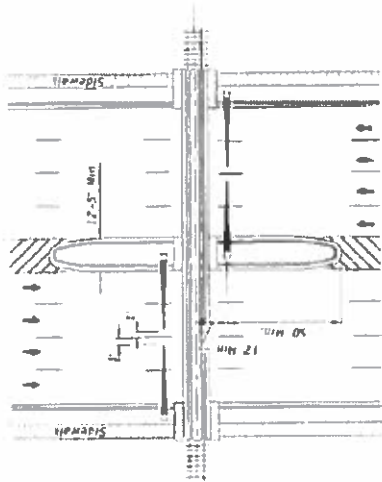

PLAN

REVISION
DATE
BY

STANDARD PLANS
FY 2022-23

RAILROAD GRADE CROSSING
TRAFFIC CONTROL DEVICES

INDIC
509-070
SHEET
3 of 3