

Memorandum



Date: April 4, 2023

To: Honorable Chairman Oliver G. Gilbert, III
and Members, Board of County Commissioners

Agenda Item No. 8(N)(8)

From: Daniella Levine Cava
Mayor

A handwritten signature in blue ink that reads "Daniella Levine Cava".

Subject: Off-System Project Limits Agreement to Implement Local Roadway Improvements between Miami-Dade County and the Florida Department of Transportation for FM# 447798-1-52-01 at SR 5 / US-1 from S of SW 264 ST to S of SW 232 ST

Executive Summary

The purpose of this item is for the Board of County Commissioners (Board) to approve an Off-System Project Limits Agreement between Miami-Dade County and the Florida Department of Transportation (FDOT) for the implementation of Local Roadway Improvements within a project on FM# 447798-1-52-01, i.e., SR 5 / US-1 from S of SW 264 ST to S of SW 232 ST on Old Dixie Hwy. Some of the specific improvements are pavement restoration through milling and resurfacing, ADA improvements such as upgrading pedestrian ramps and detectable warnings and replacing signal and lighting pull boxes within sidewalk reconstruction. The project is estimated to cost \$58,666.82 and will be funded and built by FDOT. The anticipated construction start date is September 2024.

Recommendation

It is recommended that the Board approve the attached resolution authorizing the execution of an Off-System Project Limits Agreement between the County and FDOT for the construction of improvements within a project on FM# 447798-1-52-01, SR 5 / US-1 S of SW 264 ST to S of SW 232 ST on Old Dixie Hwy. The estimated project cost of \$58,666.82 will be funded by FDOT.

Scope

The Project is in District 9, which is represented by Commissioner Kionne McGhee.

Delegation of Authority

The authority of the County Mayor or County Mayor's designee to execute and implement this agreement, including exercising all the provisions contained therein, is consistent with those authorities granted under the Code of Miami-Dade County.

Fiscal Impact/Funding Source

The project is estimated to cost \$58,666.82 and will be funded and built by FDOT. The County is required to provide maintenance operations within the County's right-of-way upon completion of the project as part of existing maintenance efforts. There is no fiscal impact for this Project.

Track Record/Monitor

The project will be assigned to Josiel Ferrer-Diaz, Assistant Director, Traffic Services Division, Department of Transportation and Public Works (DTPW), and Maria Kunhardt, Chief, Maintenance Division, DTPW, who will be responsible for monitoring this project for the County.

Background

The improvements to be constructed are the implementation of Local Roadway Improvements. The Project shall include improvements on SR 5 / US-1 from S of SW 264 ST to S of SW 232 ST on Old Dixie Hwy and shall include but may not be limited to the following:

- Pavement restoration through milling and resurfacing;
- ADA improvements such as upgrading substandard pedestrian ramps and detectable warnings;
- Upgrading pavement markings and replacing substandard signs;
- Upgrading pedestrian signalization features; and
- Replacing signal and lighting pull boxes within sidewalk reconstruction.

If the project requires the acquisition of additional right-of-way, FDOT shall acquire such right-of-way to complete the project at no cost to the County. The anticipated construction start date is September 2024.



Jimmy Morales
Chief Operations Officer



MEMORANDUM
(Revised)

TO: Honorable Chairman Oliver G. Gilbert, III
and Members, Board of County Commissioners

DATE: April 4, 2023

FROM: 
Gen Bonzon-Keenan
County Attorney

SUBJECT: Agenda Item No. 8(N)(8)

Please note any items checked.

- "3-Day Rule" for committees applicable if raised
- 6 weeks required between first reading and public hearing
- 4 weeks notification to municipal officials required prior to public hearing
- Decreases revenues or increases expenditures without balancing budget
- Budget required
- Statement of fiscal impact required
- Statement of social equity required
- Ordinance creating a new board requires detailed County Mayor's report for public hearing
- No committee review
- Applicable legislation requires more than a majority vote (i.e., 2/3's present ____, 2/3 membership ____, 3/5's ____, unanimous ____, CDMP 7 vote requirement per 2-116.1(3)(h) or (4)(c) ____, CDMP 2/3 vote requirement per 2-116.1(3)(h) or (4)(c) ____, or CDMP 9 vote requirement per 2-116.1(4)(c)(2) ____) to approve
- Current information regarding funding source, index code and available balance, and available capacity (if debt is contemplated) required

Approved _____ Mayor
Veto _____
Override _____

Agenda Item No. 8(N)(8)
4-4-23

RESOLUTION NO. _____

RESOLUTION APPROVING AN OFF-SYSTEM PROJECT LIMITS IMPROVEMENT AGREEMENT BETWEEN MIAMI-DADE COUNTY AND THE FLORIDA DEPARTMENT OF TRANSPORTATION FOR LOCAL ROADWAY IMPROVEMENTS SR 5 / US-1 FROM S OF SW 264 ST TO S OF SW 232 ST, A PORTION OF WHICH IS ON OLD DIXIE HWY, IN MIAMI-DADE COUNTY, FLORIDA, A ROAD NOT ON THE STATE HIGHWAY SYSTEM; AND AUTHORIZING THE COUNTY MAYOR OR COUNTY MAYOR'S DESIGNEE TO EXECUTE THE AGREEMENT AND EXERCISE ALL THE PROVISIONS CONTAINED THEREIN

WHEREAS, this Board desires to accomplish the purposes outlined in the accompanying memorandum, a copy of which is incorporated herein by reference,

NOW, THEREFORE, BE IT RESOLVED BY THE BOARD OF COUNTY COMMISSIONERS OF MIAMI-DADE COUNTY, FLORIDA, that this Board approves the Off-System Project Limits Agreement between Miami-Dade County and the Florida Department of Transportation, for the implementation of Local Roadway Improvements at SR 5 / US-1 from S of SW 264 ST to S of SW 232 ST, on Old Dixie Hwy from Sta 409+41 to Sta 413+07, in substantially the form attached hereto and incorporated herein; and authorizes the County Mayor or County Mayor's designee to execute same for and on behalf of Miami-Dade County and to exercise the provisions contained therein.

The foregoing resolution was offered by Commissioner _____, who moved its adoption. The motion was seconded by Commissioner _____ and upon being put to a vote, the vote was as follows:

Oliver G. Gilbert, III, Chairman
Anthony Rodríguez, Vice Chairman

Marleine Bastien	Juan Carlos Bermudez
Kevin Marino Cabrera	Sen. René García
Roberto J. Gonzalez	Keon Hardemon
Danielle Cohen Higgins	Eileen Higgins
Kionne L. McGhee	Raquel A. Regalado
Micky Steinberg	

The Chairperson thereupon declared this resolution duly passed and adopted this 4th day of April, 2023. This resolution shall become effective upon the earlier of (1) 10 days after the date of its adoption unless vetoed by the County Mayor, and if vetoed, shall become effective only upon an override by this Board, or (2) approval by the County Mayor of this resolution and the filing of this approval with the Clerk of the Board.

MIAMI-DADE COUNTY, FLORIDA
BY ITS BOARD OF
COUNTY COMMISSIONERS

LUIS G. MONTALDO, CLERK AD INTERIM

By: _____
Deputy Clerk

Approved by County Attorney as
to form and legal sufficiency.



Eduardo W. Gonzalez

OFF-SYSTEM CONSTRUCTION AND MAINTENANCE AGREEMENT

Between

**STATE OF FLORIDA, DEPARTMENT OF TRANSPORTATION
("DEPARTMENT")**

and

**Miami-Dade County, a political subdivision of the State of Florida
("COUNTY")**

THIS AGREEMENT is made and entered into as of _____, 2022, by and through the STATE OF FLORIDA DEPARTMENT OF TRANSPORTATION, an agency of the State of Florida (the "Department"), and Miami-Dade County, Florida, a political subdivision of the State of Florida (the "COUNTY"), collectively referred to as the "Parties."

RECITALS

A. Upon approval of the Department's Work Program by the State of Florida Legislature, and adoption by the Department Secretary, the Department shall complete the various projects included in the Department Work Program; and

B. Included in the Department Work Program is Project Number FM# 447798-1-52-01, SR 5 / US-1 / S Dixie Hwy [*from S of SW 264 St to S of SW 232 St*] (the "Project"). A portion of the Project includes work on Old Dixie Hwy, in Miami-Dade County, Florida, a road not on the State Highway System; and

C. The County is the holder of ownership rights to Old Dixie Hwy, a road not on the State Highway System; and

D. The Parties agree that it is in the best interest of each party for the Department to undertake and to complete all aspects of the Project, including but not limited to, the design, construction, construction inspection, maintenance during construction, utilities, easements, and other associated tasks; and

E. The Parties further agree that it is in the best interest of each party to enter into this Agreement in order to allow the Department to construct and complete the Project.

TERMS

NOW THEREFORE, in consideration of the premises, the mutual covenants and other valuable considerations contained herein, the receipt and sufficiency of which are hereby acknowledged, the Parties agree as follows:

1. The recitals in this Agreement are true and correct, and incorporated into and made a part hereof.
2. The Parties agree that the Department intends to undertake and complete Project Number FM# 447798-1-52-01, which Project generally includes the following:
 - pavement restoration through milling and resurfacing;
 - ADA improvements such as upgrading substandard pedestrian ramps and detectable warnings;
 - upgrading pavement markings and replacing substandard signs;
 - upgrading pedestrian signalization features; and
 - replacing signal and lighting pull boxes within sidewalk reconstruction.

The Project shall include improvements on Old Dixie Hwy, from Sta 409+41 to Sta 413+07 (for purposes of this agreement, the “Off-System Project Limits”). The work within the Off-System Project Limits shall include, but may not be limited to the following (hereinafter referred to as the “Local Roadway Improvements”):

- a) pavement restoration through milling and resurfacing;
- b) upgrading pedestrian median crossing across Old Dixie Hwy; and
- c) upgrading pavement markings and replacing substandard signs.

The Project shall further include all activities associated with or arising out of the construction of the Local Roadway Improvements. In the event that the Project requires the acquisition of additional right-of-way within the Off-System Project Limits, the Department shall acquire such right-of-way in order to complete the Project. The County shall cooperate with and shall support the Department’s work efforts in these regards.

The Department will design and construct the Project in accordance with all applicable federal and state laws and regulations and in accordance with Department design and construction standards as set forth in the Department's guidelines, standards, and procedures. The Department shall have final decision authority with respect to the design, the design review process, and construction of the Local Roadway Improvements, and the relocation of any utilities that the Department may determine to be required.

3. The Parties acknowledge and agree that the County will review the Project Design Plans ("Project Design Plans") and shall submit its comments, if any, via Electronic Reviewer Comments ("ERC"). The Department shall provide the County access to the ERC, and the Department shall use the ERC to submit the Project Design Plans for the County to review. When the Department places the Project Design Plans in the ERC, the Department will designate a Comment Due Date and a Response Due Date. The County shall submit its comments with regards to the Project Design Plans on or before the Comment Due Date, and the Department shall respond to the County's comments, if any, on or before the Response Due Date. If the County does not submit its comments by the Comment Due Date, the County will be deemed to have approved the Project Design Plans submitted by the Department. The review process for the Project Design Plans will be deemed concluded when the Department has submitted the Final Project Design Plans to the ERC, and the Comment Due Date and Response Due Date for the Final Project Design Plans have passed, and the Department has addressed all of the County's comments that were submitted through the ERC. Once the review process is concluded, the Department will construct the Project in accordance with the Final Project Design Plans submitted through the ERC. The County acknowledges and agrees that, during construction of the Local Roadway Improvements, the Department will only utilize the services of law enforcement officers when required by the Department's Standard Specifications for Road and Bridge Construction, and no additional requirements will be imposed. No further agreements or permits shall be required for production or construction of this Project.

Major modifications of the approved Project Design Plans must be submitted to the County for review. A "Major Modification" is any modification that materially alters the kind or nature of the work depicted in the approved Project Design Plans, or that alters the integrity or maintainability of the Local Roadway Improvements, or related components. The County's review shall be within the reasonable time schedule proposed by the Department, in order to

avoid delay to the Department's construction contract. In the event that any Major Modifications are required during construction, the Department shall be entitled to proceed with the modifications that are necessary to complete the construction of the Project, and shall, upon identifying the need for a Major Modification, immediately notify the County of the required changes prior to proceeding with implementation of the same. It is specifically understood and agreed that any such changes during construction shall not delay nor affect the timely construction schedule of the Project.

4. The County agrees to fully cooperate with the Department in the construction, reconstruction and relocation of utilities that are located within the County's right-of-way, within the Off-System Project Limits. The utility relocations, if any, which may be required by the Department for purposes of the Project, shall be done in accordance with the Department's guidelines, standards and procedures. The Department shall submit the proposed utility relocation schedule to the County. Utility relocations, if any, shall be done in accordance with the provisions of Chapter 337, F. S.

Additionally, the County agrees to fully cooperate with the Department in the removal of any encroachments or permitted improvements, and in the modification of any driveway connections, located within the County's right-of-way, within the Off-System Project Limits, that are in conflict with the Project, and the County hereby authorizes the Department to take any legal action necessary to effectuate the removal of any such conflicting encroachments or permitted improvements, and to effectuate the modification of any such driveway connections. The Department shall coordinate with the County for said removals or modifications, at no cost to the County.

5. The County agrees to perpetually maintain the Local Roadway Improvements. To maintain means to perform normal maintenance operations for the preservation of the Local Roadway Improvements, which shall include but is not limited to, roadway surfaces, shoulders, roadside structures, drainage, signing and pavement markers, lighting, and such traffic control devices as are necessary for the safe and efficient use of the Local Roadway Improvements.

Additionally, the Parties understand and agree that the Department shall transfer any permit(s) required for the construction of the Local Roadway Improvements, if any, to the County as the operational maintenance entity, and the County agrees to accept said transfer and to be fully

responsible to comply with all operational and maintenance conditions of the permit(s), at its sole cost and expense.

Notwithstanding the requirements hereof, maintenance during construction shall be the responsibility of the Department and its Contractor, as set forth in paragraph 9 of this Agreement.

6. The Parties acknowledge and agree that the County's right-of-way and the improvements and structures located within the County's right-of-way, are and will remain under the ownership of the County, and that the Department will not have any ownership interest in the right-of-way, improvements, or structures located thereon or installed therein pursuant to this Project.
7. The Department shall require its construction Contractor to maintain, at all times during construction, Commercial General Liability insurance providing continuous coverage for all work or operations performed under the construction contract. Such insurance shall be no more restrictive than that provided by the latest occurrence form edition of the standard Commercial General Liability Coverage Form (ISO Form CG 00 01) as filed for use in the State of Florida. The limits of coverage shall not be less than \$1,000,000 for each occurrence and not less than a \$5,000,000 annual general aggregate, inclusive of amounts provided by an umbrella or excess policy, or such other minimum insurance coverage that may be required by the Department for the construction of the Project, in accordance with the Department's Standards and Specifications for Road and Bridge Construction. The Department shall further cause its Contractor to name the County and the Department as additional insured Parties on the afore-stated policies, and to provide evidence of Workers' Compensation Insurance in accordance with the laws of the State of Florida and in amounts sufficient to secure the benefit of the Florida Workers' Compensation law for all employees.
8. The Department shall notify the County at least 48 hours before beginning construction within the County's right-of-way. Such notification may be provided via email, to the Director of the Department of Transportation and Public Works, and the notice requirements set forth in paragraph 20 shall not apply to this paragraph.

The Department agrees that the County may, at reasonable times during the construction of the Local Roadway Improvements, inspect the Contractor's construction site and perform such tests as are reasonably necessary to determine whether the goods or services required to be provided by the Contractor, pursuant to the Contractor's Construction Agreement with the Department, conform to the terms of said Construction Agreement. Upon request by the County, the

Department shall coordinate with its Contractor to provide access to the County for performance of said inspections.

During the construction work related to the Project, the County shall fully cooperate with any such work being performed by the Department and the Department's contractors. The County shall not commit nor permit any act which may delay or interfere with the performance of any such work by the Department or the Department's contractors, unless the Department agrees in writing that the County may commit or permit said act.

9. Maintenance during construction within the Off-System Project Limits, commencing as of the first date of construction, shall be the responsibility of the Department's Contractor. Notwithstanding, neither the Department nor its Contractor shall be responsible for mowing or removing litter during construction of the Project. After completion of construction, the County shall assume all maintenance responsibilities for the Local Roadway Improvements. Upon completion of construction, the Department is required to invite the County on the Final Inspection of the work within the Off-System Project Limits, and will incorporate legitimate County concerns that are within the scope of the contract into the final Project punch list to be corrected by the Contractor. Notice for Final Inspection shall be delivered via email to the Division Director of the County Road, Bridge and Canal Maintenance Division (Department of Transportation and Public Works) and the notice provision of paragraph 20 shall not be applicable. However, if the County does not attend the Final Inspection, the Department shall proceed to conduct the Final Inspection, finalize the Project punch list, and issue a Notice of Final Acceptance to its Contractor. The Final Inspection shall be performed and the Notice of Final Acceptance shall be issued in accordance with the Department's Standard Specifications for Road and Bridge Construction and the Construction Project Administration Manual (CPAM).

Upon issuance of the Notice of Final Acceptance to the Contractor, the Department shall provide a copy of said notice to the County. As of the date of the Notice of Final Acceptance, the County shall be immediately responsible for the maintenance of the Local Roadway Improvements, and shall further accept the Local Roadway Improvements. The Department, however, shall have the right to assure completion of any punch list by the Contractor. Notwithstanding the issuance of the Notice of Final Acceptance, the County may notify the Department Project Manager of deficiencies in the Local Roadway Improvements that may be covered by the warranty provisions

in the contract between the Department and its Contractor. The Department shall enforce the warranty if remedial action is required by the warranty provisions, as determined by the Department.

Upon completion of all work related to construction of the Project, the Department will be required to submit to the County final as-built plans for the Local Roadway Improvements and an engineering certification that construction was completed in accordance with the plans. Additionally, the Department shall vacate those portions of the County's right-of-way used to construct the Local Roadway Improvements, and shall remove the Department's property, machinery, and equipment from said portions of the County's right-of-way. Furthermore, the Department shall restore those portions of the County right-of-way disturbed by Project construction activities to the same or better condition than that which existed immediately prior to commencement of the construction of the Project.

10. Upon submission by the Department of a deed, with accompanying sketch and legal description, for the transfer to the County of any additional right-of-way acquired by the Department within the Off-System Project Limits, the County shall forthwith submit the same to its governing board or commission for approval and acceptance of such additional right-of-way.
11. This Agreement shall become effective as of the date both parties hereto have executed the Agreement. Prior to commencement of construction, the Department may in its sole discretion terminate this Agreement if it determines that it is in the best interest of the public to do so. If the Department elects to terminate this Agreement, the Department shall deliver formal notice of termination to the County, as set forth in paragraph 20 of this Agreement.
12. In the event that any election, referendum, approval, ratification, notice or other proceeding, or authorization is required to carry out the Project, the County agrees to expeditiously initiate and consummate, as provided by law, all actions necessary with respect to any such matters, with time being of the essence.
13. The Department may utilize federal funds to design and construct the Project. In the event that the Project shall be constructed using federal funds, all costs incurred must be in conformity with applicable federal and state laws, regulations, and policies and procedures.
14. The Department's performance and obligations under this Agreement are contingent upon an annual appropriation by the Legislature. If the Department's funding for this Project is in multiple

fiscal years, funds approval from the Department's Comptroller must be received each fiscal year prior to costs being incurred.

15. In the event that this Agreement is in excess of \$25,000, and the Agreement has a term for a period of more than one year, the provisions of Section §339.135(6)(a), Florida Statutes, are hereby incorporated into this Agreement and are as follows:

"The department, during any fiscal year, shall not expend money, incur any liability, or enter into any contract which, by its terms, involves the expenditure of money in excess of the amounts budgeted as available for expenditure during any such fiscal year. Any contract, verbal or written, made in violation of this subsection is null and void, and no money may be paid on such contract. The department shall require a statement from the comptroller of the department that funds are available prior to entering into any such contract or other binding commitment of funds. Nothing herein contained shall prevent the making of contracts for periods exceeding 1 year, but any contract so made shall be executory only for the value of the services to be rendered or agreed to be paid for in succeeding fiscal years; and this paragraph shall be incorporated verbatim in all contracts of the department which are for an amount in excess of \$25,000 and which have a term for a period of more than 1 year."

16. The Department is a state agency, self-insured and subject to the provisions of Section 768.28, Florida Statutes. Nothing in this Agreement shall be deemed or otherwise interpreted as waiving the Department's sovereign immunity protections, or as increasing the limits of liability as set forth in Section 768.28, Florida Statutes.

17. A modification or waiver of any of the provisions of this Agreement shall be effective only if made in writing and executed with the same formality as this Agreement.

18. This Agreement shall be governed by the laws of the State of Florida. Any provision hereof found to be unlawful or unenforceable shall be severable and shall not affect the validity of the remaining portions hereof. Venue for any and all actions arising out of or in any way related to the interpretation, validity, performance or breach of this Agreement shall lie exclusively in a state court of appropriate jurisdiction in Leon County, Florida.

19. No term or provision of this Agreement shall be interpreted for or against any party because that party's legal counsel drafted the provision.

20. In accordance with Executive Order No. 11-02 the Department's Vendor/Contractor(s) shall utilize the U.S. Department of Homeland Security's E-Verify system, in accordance with the

terms governing use of the system, to confirm the employment eligibility of;

- i. all persons employed by the Vendor/Contractor during the term of the Contract to perform employment duties within Florida; and
- ii. all persons, including subcontractors, assigned by the Vendor/Contractor to perform work pursuant to the contract with the Department.

21. All notices required pursuant to the terms hereof, shall be in writing and shall be sent by first class United States Mail, facsimile transmission, hand delivery or express mail. Notices shall be deemed to have been received by the end of five (5) business days from the proper sending thereof unless proof of prior actual receipt is provided. Unless otherwise notified in writing, notices shall be sent to the following:

To the County:

Director, Miami-Dade County Department of Transportation and Public Works
701 NW 1 Court Suite 1700

Miami, FL 33136

To the Department:

Director of Transportation Operations
State of Florida, Department of Transportation
1000 N.W. 111th Avenue
Miami, Florida 33172

22. The County, by and through Resolution No. _____, attached hereto as Exhibit "____", has duly authorized the execution and delivery of this Agreement and agrees to be bound by the terms hereunder, and has further authorized the Mayor or his designee to take all necessary steps to effectuate the terms of this Agreement.

IN WITNESS WHEREOF, the parties hereto have executed this Agreement on the dates exhibited, by the signatures below.

**STATE OF FLORIDA
DEPARTMENT OF TRANSPORTATION**

By: _____

By: _____

Name: _____

Name: _____

Title: _____

Title: Director of Transportation Operations

Date: _____

Date: _____

Attest: _____

Name: _____

Title: _____

Approved as to form and legality:

Department Legal Review:

By: _____

Name: _____

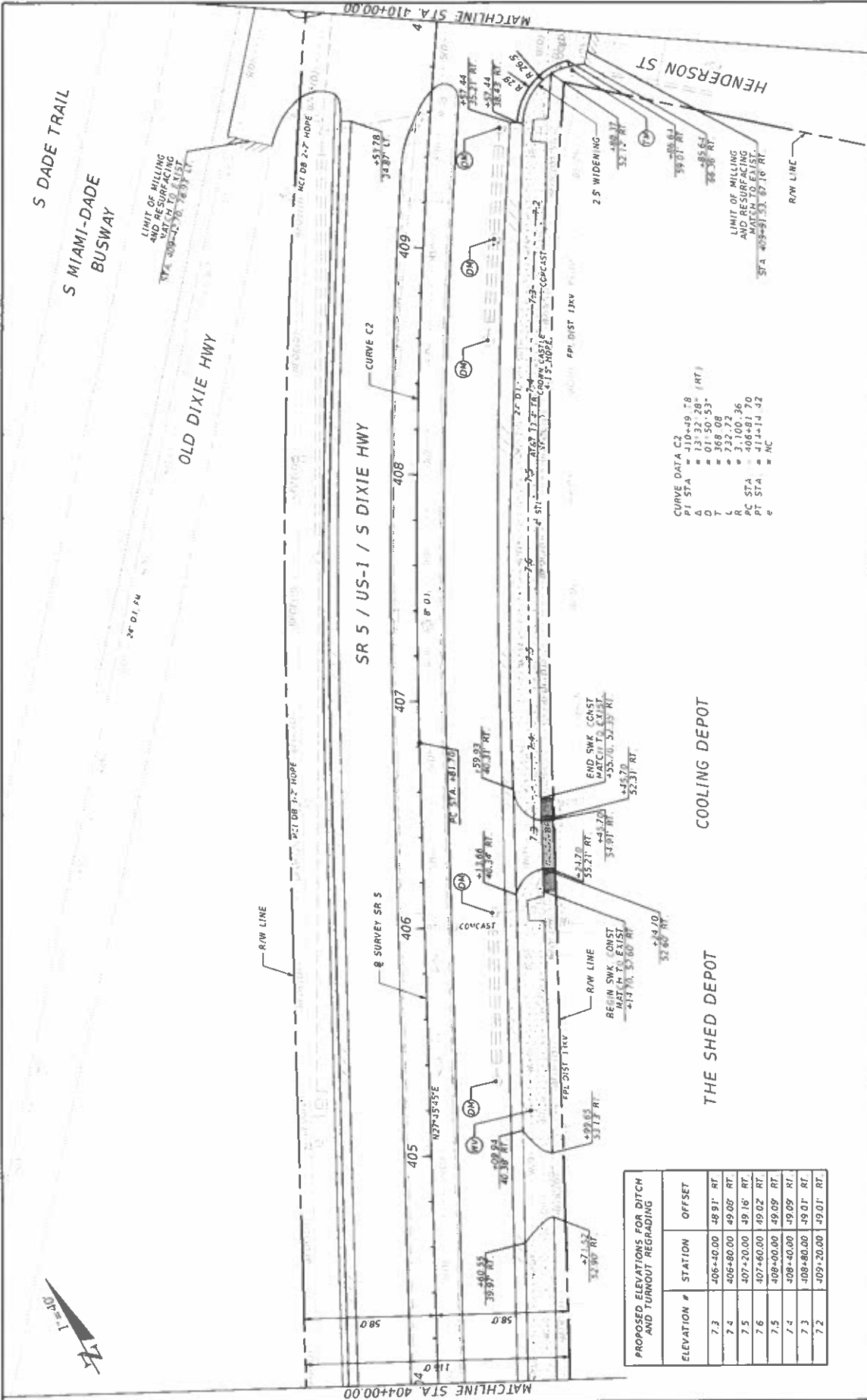

STATE OF FLORIDA DEPARTMENT OF TRANSPORTATION		ROAD NO. SR 5		COUNTY MIAMI-DADE		FINANCIAL PROJECT ID 447798-1-52-01	
ENGINEER OF RECORD HANS C. RIBBECK, P.E. LICENSE NUMBER 70961 RIBBECK ENGINEERING, INC. 1-1335 SW 120 STREET, SUITE 205 MIAMI, FL 33186				ROADWAY PLANS			
DATE		DESCRIPTION		REVISIONS		SHEET NO. 18	

THE OFFICIAL RECORD OF THIS SHEET IS THE ELECTRONIC FILE DIGITALLY SIGNED AND SEALED UNDER RULE 61G15-23.004, F.A.C.

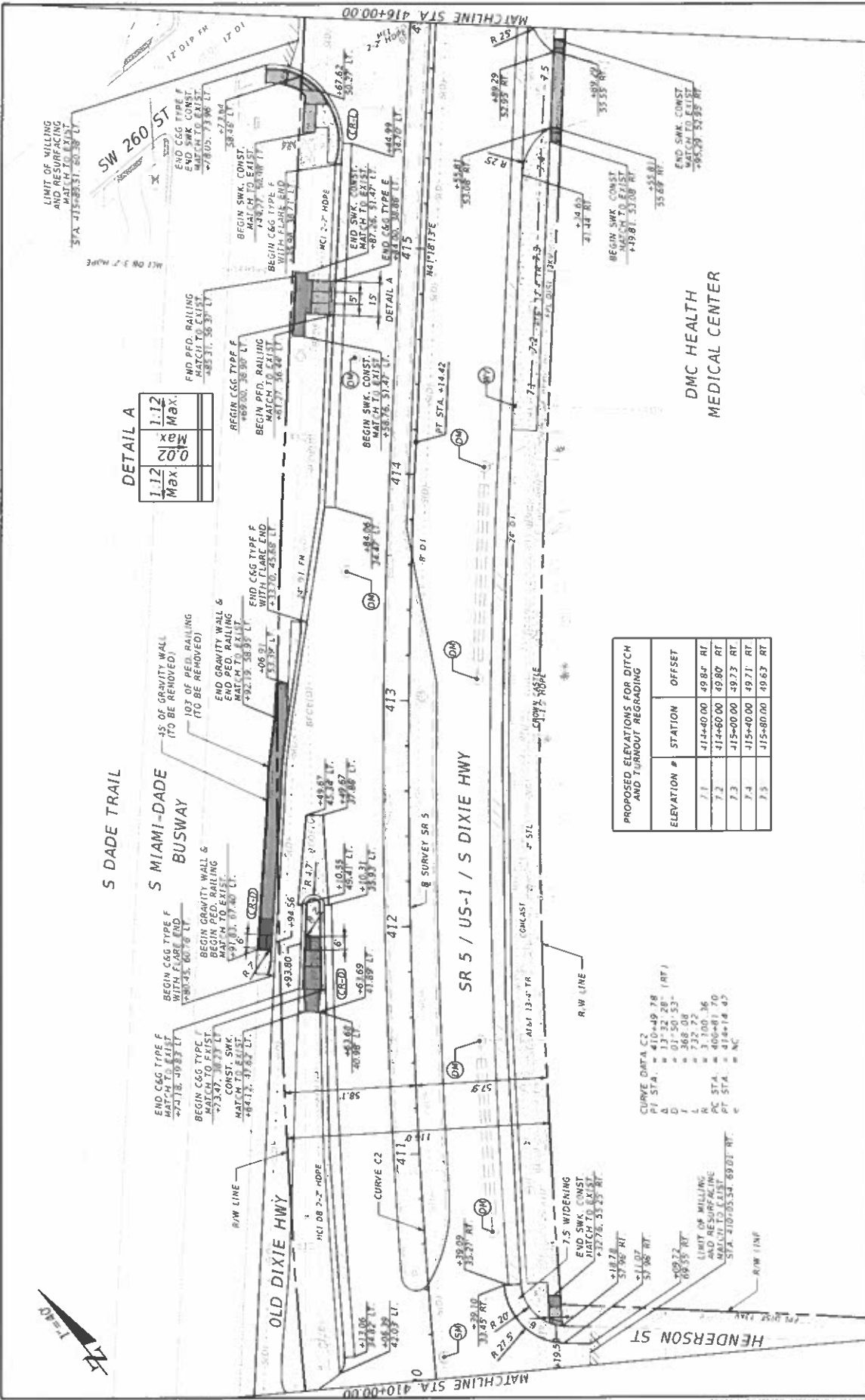

DETAIL A

1.12	1.12
Max	Max

PROPOSED ELEVATIONS FOR DITCH AND TURNOUT REGRADING

ELEVATION #	STATION	OFFSET
7.1	414+00.00	49.87 RT
7.2	414+60.00	49.80 RT
7.3	415+00.00	49.73 RT
7.4	415+40.00	49.71 RT
7.5	415+80.00	49.63 RT

CURVE DATA C3

PT STA	410+49.78
Δ	13° 32' 28" (RT)
D	01' 50' 53"
L	368.08'
L	732.22'
PC STA	408' 17.0'
PT STA	418' 14.43'
NC	NC

DATE	DESCRIPTION	REVISIONS	DESCRIPTION	DATE
ENGINEER OF RECORD: HANS C. RIBBECK, P.E. LICENSE NUMBER 70904 RIBBECK ENGINEERING, INC. 14335 SW 130 STREET, SUITE 205 MIAMI, FL 33186				
STATE OF FLORIDA		DEPARTMENT OF TRANSPORTATION		SHEET NO.
ROAD NO.		COUNTY		19
SR 5		MIAMI-DADE		
FINANCIAL PROJECT ID		447798-152-01		
ROADWAY PLANS				

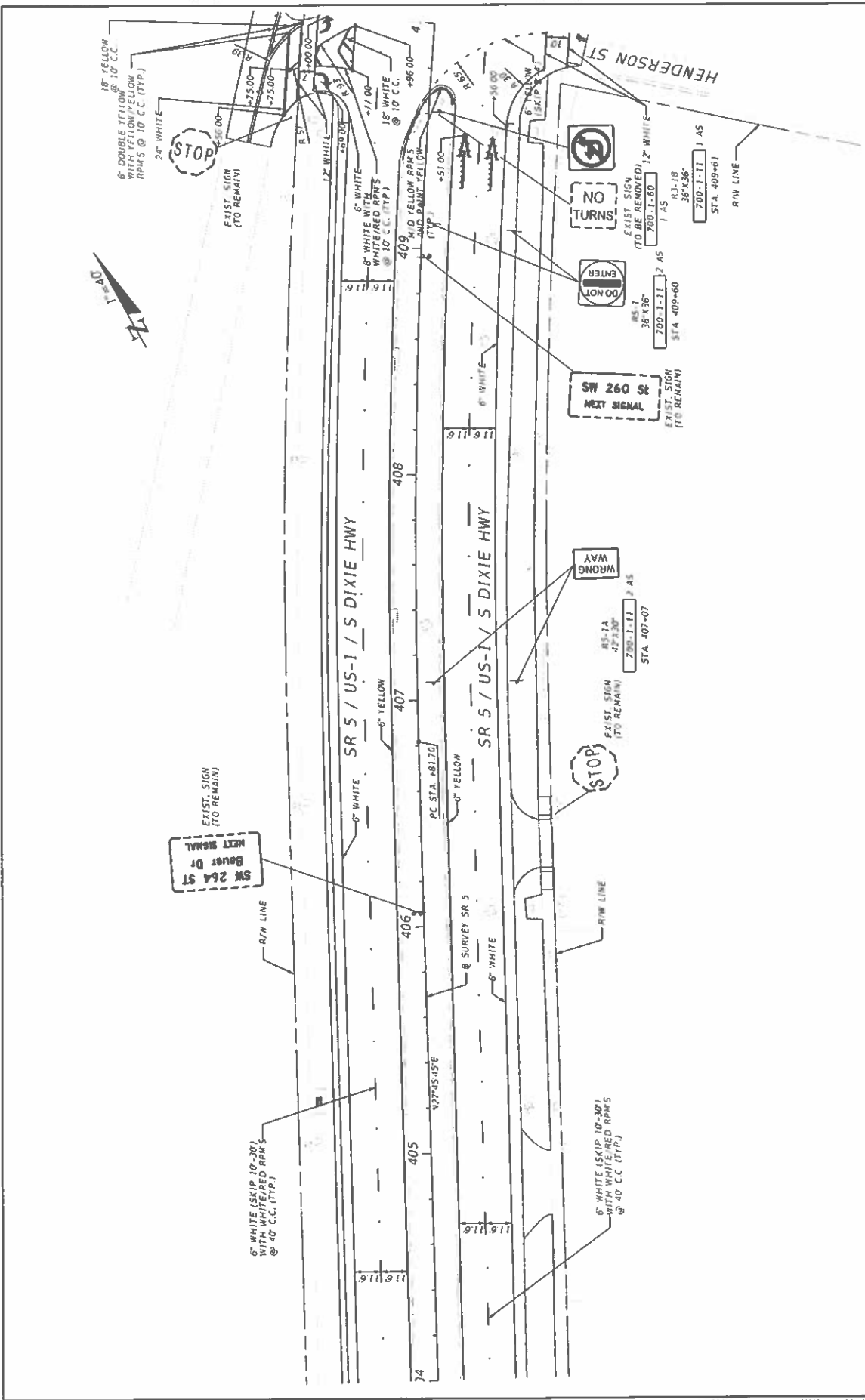

REVISIONS		DESCRIPTION	
DATE	DESCRIPTION	DATE	DESCRIPTION

ENGINEER OF RECORD		STATES OF FLORIDA	
ALEJANDRO URIBE, P.E.		DEPARTMENT OF TRANSPORTATION	
LICENSE NUMBER 75596		ROAD NO.	COUNTY
GANNETT FLEMING, INC.		SR 5	MIAMI-DADE
800 NW 62ND AVENUE, SUITE 490		FINANCIAL PROJECT ID	447798-1-32-01
MIAMI, FL 33126			

SIGNING AND PAVEMENT MARKING PLAN		SHEET NO.
		S-5

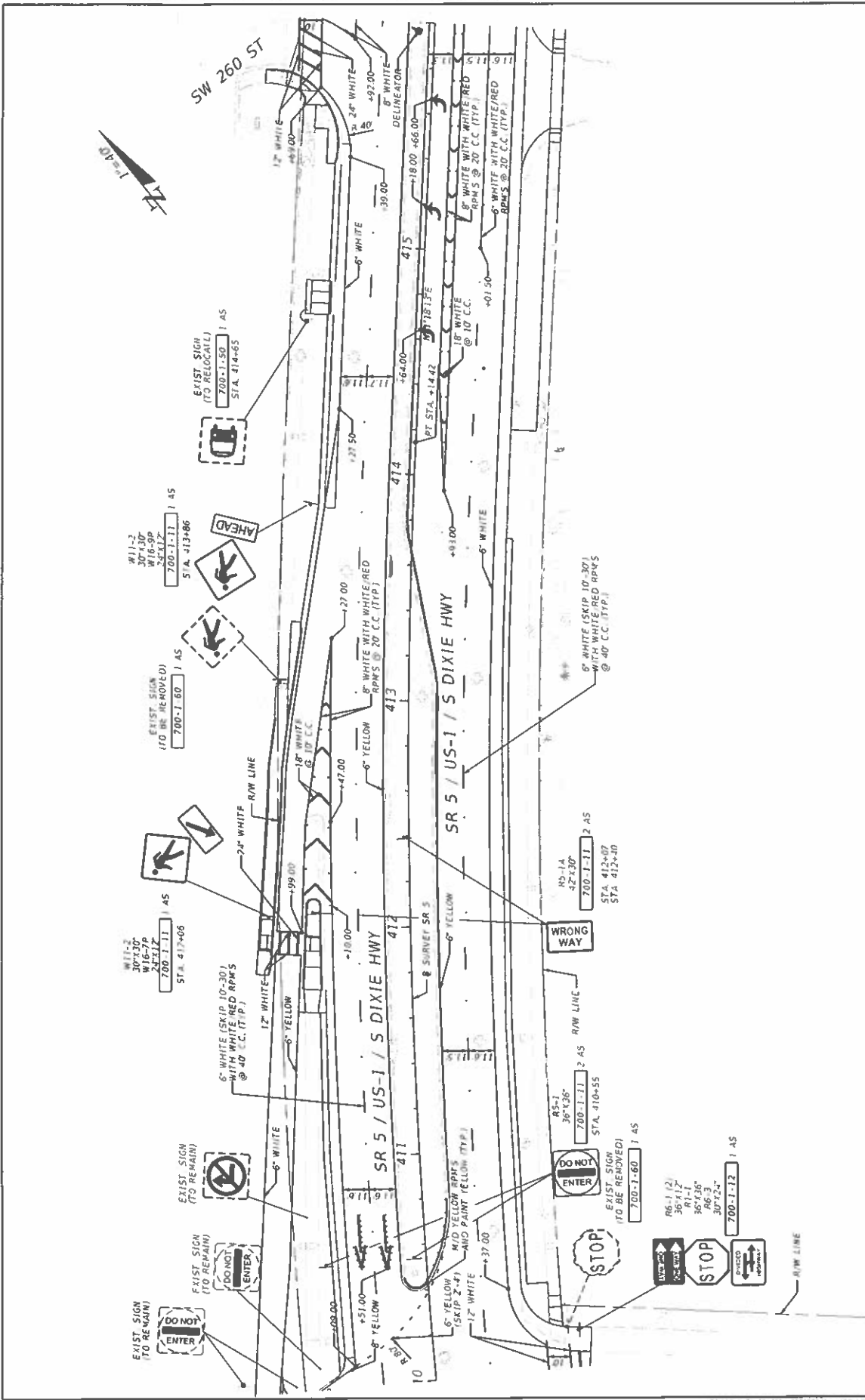

DATE		DESCRIPTION		REVISIONS		ENGINEER OF RECORD		DEPARTMENT OF TRANSPORTATION		STATE OF FLORIDA	
								SR 5	MIAMI DADE	447798-1-12 01	FINANCIAL PROJECT ID
								SR 5	MIAMI DADE	447798-1-12 01	SHEET NO.
											1-6