

Memorandum



Date: (Public Hearing: 12-16-25)
October 21, 2025

To: Honorable Chairman Anthony Rodriguez
and Members, Board of County Commissioners

From: Daniella Levine Cava *Daniella Levine Cava*
Mayor

Subject: Ordinance Creating the Acacia Groves Multipurpose Maintenance and Street Lighting
Special Taxing District

Agenda Item No. 5(C)

Executive Summary

The purpose of this item is to gain authorization from the Board of County Commissioners (Board) to create a special taxing district in unincorporated Miami-Dade County (County) for the installation of streetlights and/or the maintenance of landscaping in the public Rights-of-Way.

Recommendation

It is recommended that the Board approve a petition submitted in accordance with Article I, Chapter 18, of the Code of Miami-Dade County (Code) for the creation of the Acacia Groves Multipurpose Maintenance and Street Lighting Special Taxing District (Special Taxing District). The creation of this Special Taxing District is a subdivision requirement pursuant to Chapter 28 of the Code. The multipurpose maintenance program will remain dormant until any association or community development district (CDD) fails to provide the required maintenance services.

Scope

This proposed Special Taxing District lies within Commission District 9, which is represented by Vice Chairman Kionne L. McGhee, and will provide street lighting services and, if and when necessary, multipurpose maintenance services.

Fiscal Impact/Funding Source

Creation of this Special Taxing District will result in no economic impact on the County's budget and there will be no increase or decrease in County staffing. The developer, pursuant to Chapter 18 of the Code, is required to fund the Special Taxing District's first year's lease of the equipment and electricity costs to operate the street lighting system and all incidental costs incurred by the County for the creation and administration of the Special Taxing District. Maintenance services which cannot be equitably or conveniently provided by the property owners shall be provided by the Special Taxing District upon acceptance of the plat's required services by the County, and such services will be funded by special assessments against benefited properties.

After the first year, there will be a perpetual annual special assessment for the cost of street lighting and multipurpose maintenance services to all property owners within the Special Taxing District. Florida Power and Light (FPL) is the owner of the system and will derive revenues from the creation of the Special Taxing District. FPL's contractors and subcontractors may increase their staffing levels to provide the service requirements created by this Special Taxing District.

Social Equity Statement

The proposed Ordinance creates the Special Taxing District, pursuant to Article 1, section 1.01(A)(11) of the Miami-Dade County Home Rule Charter and Chapter 18 of the Code. If approved, property owners within the proposed Special Taxing District will pay special assessments appropriately apportioned according to the special benefit they receive from the Special Taxing District's services, regardless of their demographics, and that the total estimated amount of the special assessments to be levied would not be in excess of such special benefit. The creation of this Special Taxing District, which was requested by 100% of the property owners, will provide for lighting continuity between contiguous Street Lighting Special Taxing Districts on connecting roadways, allow higher intensity spotlighting at specific locations, and accommodate future County lighting standards. The creation of this Special Taxing District will also provide for maintenance services.

Pursuant to section 18-20.2(b) of the Code regarding notice to purchasers of new residential property, it shall be the obligation of a seller of new residential property to provide the purchaser thereof with notice either of the existence of a special taxing district created pursuant to this Chapter of the Code or of a pending petition to create such a special taxing district. The notice shall be provided in the manner set forth in section 18-20.2 of the Code.

Track Record/Monitor

The Special Taxing District will be managed by the County's Parks, Recreation and Open Spaces Department (PROS) and overseen by the Chief of the Special Assessment Districts Division (Division), Liset Romero-Lopez.

Delegation of Authority

This item authorizes the County Mayor or County Mayor's designee to execute lighting agreements, as required by FPL to provide street lighting, following approval by the County Attorney's Office as to legal sufficiency. In the event any association or CDD fails to provide the maintenance services, this item further authorizes the County Mayor or County Mayor's designee, contingent upon Board adoption of a non-ad valorem assessment roll, to provide the Special Taxing District's required maintenance services and cause implementation of special assessments for the costs of such services against the property owners within the Special Taxing District, as well as contract monitoring, compliance and enforcements, if and when necessary.

Background

In accordance with the provisions of Chapter 18 of the Code, a petition to create the Special Taxing District, duly signed by 100% of the owners of property within the proposed Special Taxing District, was filed with the Clerk of the Board (Clerk). A copy of the petition was sent to the County Mayor and the County Attorney to examine and to file a written report with the Clerk certifying that such petition was sufficient in form and substance and signed and properly presented in accordance with the requirements of Chapter 18 of the Code. PROS compiled and filed with the Clerk a memorandum, and accompanying written report and recommendations (Report), a copy of which is attached to the memorandum. The Report sets forth the boundaries of the Special Taxing District, an estimate of the cost of the improvements and/or services to be provided, the need for and desirability of the Special Taxing District, the ability of the affected properties

to bear the special assessments, certifies that the improvements and/or services to be provided conform to the master plan of Miami-Dade County, and recommends that the Special Taxing District be created to provide a special benefit to all property within the proposed Special Taxing District.

Contingent upon Board approval of the creation of this Special Taxing District, the street lighting services will be accomplished pursuant to an agreement between the County and FPL. The facilities provided will remain the property of FPL. FPL will be responsible for the maintenance, repairs, upgrades, and replacement of the light fixtures, lamps, poles, and all connecting service lines. The Division will administer FPL's agreement, installation, and billing process. PROS and the Division will provide the Special Taxing District's required maintenance services and cause implementation of special assessments for the costs of such services against the benefited properties, as well as contract monitoring, compliance and enforcements, if and when necessary.

Boundaries:	On the North, SW 336 Street; On the East, SW 194 Avenue; On the South, SW 340 Street; On the West, SW 197 Avenue (Richard Road).
Number of Parcels:	1 (Tentative plat proposes 195 Single-Family Homes and 49 Townhomes Units).
Number of Owners:	1
Number of Owners with Homestead Exemption Signing Petition:	None - The petition was submitted by TPG AG EHC III (LEN) MULTI STATE 2, LLC., the sole property owner and developer.
<u>Type of Services and Improvements</u> Multipurpose Maintenance Services:	The creation of this Special Taxing District is requested to maintain landscaped swales, medians, common areas, any entrance features, wetlands, lakes, and the exterior of any fencing or walls within the Special Taxing District's boundaries abutting public rights-of-way, including maintenance of turf, trees, shrubs, irrigation, and utility payments, should any association or CDD fail to provide these services. The Special Taxing District will also maintain the private road areas if there is a failure to provide maintenance within the private road areas as defined in a non-exclusive easement granted to the County and recorded in the Public Records.

Street Lighting Improvements:

It is expected that the Special Taxing District will install, operate, and maintain nineteen (19) 12,000 Lumens, 3000K bracket-arm LED streetlights mounted on new concrete poles, and nine (9) 17,000 Lumens 4000K bracket-arm LED streetlights mounted on existing concrete poles. At the discretion of the PROS Director, PROS reserves the right to adjust the quantity, style, and luminosity of the street lighting facilities, for reasons including, but not limited to, changes in field conditions, to address safety concerns, to provide for lighting continuity between contiguous Street Lighting Special Taxing Districts on connecting roadways, to allow higher intensity spotlighting at specific locations, and to accommodate future County lighting standards.

Public Hearing Notification:

The Clerk will certify the place, date, and hour for a public hearing on the petition and the Report at which all interested persons will be afforded the opportunity to present for this Board's consideration their objections, if any, to the creation and establishment of the Special Taxing District. As pursuant to section 18-3(d) of the Code, a public notice will be duly published in a newspaper of general circulation published in Miami-Dade County, Florida, and copies thereof will be mailed to all owners of taxable real property within the proposed Special Taxing District as their names and addresses appear on the latest Miami-Dade County Real Property Tax Roll.

Preliminary Public Meeting:

None necessary.

Required Referendum:

The creation of the Special Taxing District will be subject only to Board approval; no election will be necessary as 100% of the property owners signed the petition.

Preliminary Assessment Roll:

The street lighting assessment roll is submitted on the same agenda as a separate agenda item for consideration and adoption by the Board and contingent upon the approval of this Special Taxing District's creating ordinance. In the event any association or CDD fails to provide the maintenance services shown below, a hearing to adopt the Special

Taxing District's maintenance assessment roll will be conducted. The implementation of the assessment rolls will be in accordance with the procedures defined in Chapter 18 of the Code.

Estimated Initial Billing:

Assessment billed annually as an itemized portion of the Real Property tax bill.

Initial Start of Services

Multipurpose Maintenance Services:

October 1st following cessation of maintenance services by the developer and failures of any association or CDD to provide services.

Street Lighting Services:

November 2027, following the provision of street lighting services by the developer for the first year.

Method of Apportionment

Maintenance Services:

Square Footage

Street Lighting Services:

Front Footage

Estimated Annual Total District Costs

Maintenance Services:

First Year

\$0.00

Second Year

\$313,905.83

Street Lighting Services

\$49,396.35

\$9,559.17

Estimated Annual District Rates

Maintenance Services:

First Year

Costs to be

Second Year

\$0.2880

Street Lighting Services:

Provided by

\$1.9788

Petitioner

Maintenance Services:

First Year

Costs to be

Second Year

\$1,340.06

For a Typical Lot:

Provided by

Petitioner

Street Lighting Services:

First Year

Costs to be

Second Year

\$40.80

For a Typical Lot:

Provided by

Petitioner

The above annual costs and assessment information for multipurpose maintenance services are for informational purposes only and were calculated based on current costs assuming that maintenance services were to commence this year. Each subsequent year will be calculated based on actual costs. Actual costs for multipurpose maintenance services will be determined at the time of the assessment roll hearing.

Honorable Chairman Anthony Rodriguez
and Members, Board of County Commissioners
Page No. 6

The above annual street lighting costs and assessment information are based on the expected lighting services to be provided by the Special Taxing District and are subject to change in the event that the Special Taxing District's services are adjusted by the PROS Director as provided herein. Each subsequent year will be calculated based on actual costs.

State or Federal grants are not applicable to this Special Taxing District.

Each special taxing district is unique due to its geographical boundaries, affected property owners, and level of service to be provided. Creation of a new special taxing district to provide these services is the best and most cost-effective method to achieve this benefit.

In accordance with the requirements of Chapter 28 of the Code to provide street lighting in new subdivisions through the creation of Street Lighting Special Taxing Districts, and in compliance with the provisions of section 18-3 (c) of the Code, I have reviewed the facts submitted by PROS in its Report and Recommendations, a copy of which is attached and incorporated herein. I concur with their recommendation that this Special Taxing District be created pursuant to sections 18-2 and 18-22.1 of the Code. Also, I recommend the provisions of Resolution No. R-130-06 be hereby waived because adoption of this Ordinance is a precursor to the future execution of said agreement, which will not occur until development within the Special Taxing District occurs.

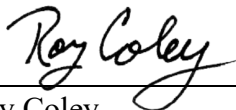

Roy Coley
Chief Utilities and Regulatory Services Officer

**REPORT AND RECOMMENDATIONS ON THE CREATION OF
ACACIA GROVES MULTIPURPOSE MAINTENANCE AND
STREET LIGHTING SPECIAL TAXING DISTRICT
MIAMI-DADE COUNTY, FLORIDA**

Pursuant to Chapter 18 of the Code of Miami-Dade County (Code), and as a result of a detailed investigation of a duly petitioned for special taxing district, the following facts are submitted by the Miami-Dade County Parks, Recreation and Open Spaces Department (PROS) Director concerning the creation of Acacia Groves Multipurpose Maintenance and Street Lighting Special Taxing District (Special Taxing District).

1. BOUNDARIES OF THIS DISTRICT

The proposed Special Taxing District is located entirely within a portion of unincorporated Miami-Dade County, and the boundaries, as set forth in the petition, are as follows:

A portion of Section 23, Township 57 South, Range 38 East, Miami-Dade County, Florida (a.k.a. Acacia Groves, Tentative Plat # T-25070); being more particularly described as follows:

The Northwest 1/4 of the Southwest 1/4 of said Section 23, less the North 35.00 feet and the West 35.00 feet of said Tract.

Also known as:

Commence at the Northwest corner of the Northwest 1/4 of the Southwest 1/4 of Section 23, Township 57 South, Range 38 East, Miami-Dade County, Florida; also being the West 1/4 corner of said Section 23, thence run along the North line of the Southwest 1/4 of said Section 23, North 89°18'22" East for a distance of 1,333.19 feet to the Northeast corner of the Northwest 1/4 of the Southwest 1/4 of said Section 23; the next two described courses being along the East line of the Northwest 1/4 of the Southwest 1/4 of said Section 23; thence South 00°23'22" East for 35.00 feet to the Point of Beginning of the following described parcel; thence continue South 00°23'22" East for 1,298.92 feet to the Southeast corner of the Northwest 1/4 of the Southwest 1/4 of said Section 23; thence run along the South line of the Northwest 1/4 of the Southwest 1/4 of said Section 23, South 89°30'47" West for a distance of 1,293.65 feet; thence run along a line parallel with and 35.00 feet easterly of, as measured at right angles to, the West line of the Southwest 1/4 of said Section 23, North 00°35'04" West for a distance of 1,294.24 feet to a point; thence run along a line parallel with and 35.00 feet southerly of, as measured at right angles to, the North line of the Southwest 1/4 of said Section 23, North 89°18'22" East for a distance of 1,298.07 feet to the Point of Beginning, containing 1,680,179 square feet more or less, or 38.572 acres more or less.

The Special Taxing District's boundaries and geographical location are shown on the attached sketch entitled Acacia Groves Multipurpose Maintenance and Street Lighting Special Taxing District and hereinafter referred to as "Exhibit A".

2. LOCATION AND DESCRIPTION OF DISTRICT

A) Multipurpose Maintenance Services – Maintenance of landscaped swales, medians, common areas, any entrance features, wetlands, lakes, and the exterior of any fencing or walls within the Special Taxing District’s boundaries abutting public rights-of-way, including maintenance of turf, trees, shrubs, irrigation, and utility payments, should any association or community development district (CDD) fail to provide these services. The Special Taxing District will also maintain the private road areas if there is a failure to provide maintenance within the private road areas as defined in a non-exclusive easement granted to Miami-Dade County (County) and recorded in the Public Records. Services will commence following failure of any association or CDD to provide these services, and upon adoption of the Special Taxing District’s multipurpose maintenance preliminary assessment roll. Other maintenance services may be provided in the future as specified in the Special Taxing District’s ordinance and amendments thereto.

B) Street Lighting Services – Installation, operation, and maintenance of public street lighting located within public rights-of-way.

3. ESTIMATED COSTS AND ANNUAL EXPENSE FOR MAINTENANCE, REPAIR AND OPERATION OF THIS DISTRICT

A) Multipurpose Maintenance Services – This initial cost estimate has been developed by PROS based on previous estimates for similar maintenance special taxing districts. The Special Taxing District will provide multipurpose maintenance services as specified in Item 2 above.

The combined costs of the multipurpose maintenance programs and operation of the Special Taxing District including services, engineering, administration, billing, collecting, and processing for the first year will be provided by the petitioners, and these costs are estimated for report purposes at \$313,905.83 for the second year. The expense of the multipurpose maintenance programs will be continuous and service costs following implementation of the Special Taxing District are to be apportioned to individual properties within the Special Taxing District on the basis of lot or parcel square footage. The combined costs of the multipurpose maintenance program and administrative expenses as shown below are to be paid for by special assessments levied against all benefited properties. Actual multipurpose maintenance costs will then be adjusted annually each year thereafter based on actual expenses.

<u>Estimated Annual District Costs</u>	<u>First Year</u>	<u>Second Year</u>
Initial Annual Maintenance	Services will be Provided by Petitioner	\$217,865.16
Engineering and Administrative Costs		\$43,573.03
Billing, Collecting and Processing Costs		\$150.00
Contingencies		<u>\$52,317.64</u>
Total Annual Maintenance Services Costs		\$313,905.83
<u>Estimated Annual District Assessments</u>	<u>First Year</u>	<u>Second Year</u>
Per Assessable Square Foot:	Costs to be Provided by Petitioner	\$0.2880
For a Typical Lot:		\$1,340.06

B) Street Lighting Services – The cost of streetlights in this Special Taxing District will be continual and is based on a preliminary estimate using Rate Schedule No. LT-1 prepared by Florida Power and Light (FPL) and approved by the Florida Public Service Commission, a copy of which is attached. FPL will install the lights, poles, and service lines at its expense and the facilities will remain the property of FPL. FPL will also be responsible for the maintenance, repairs, upgrades, and replacement of the light standards, fixtures, lamps, poles, and all connecting service lines. However, the developers, through the Special Taxing District, may be required to pay a differential cost if rapid construction techniques cannot be used on this Special Taxing District and this cost is shown in the Special Taxing District’s cost estimate below. Actual costs for the second year and each year thereafter will then be adjusted annually based on actual expenses.

<u>Estimated Annual District Costs</u>	<u>First Year</u>	<u>Second Year</u>
19 – 12,000 Lumens, 3000K Luminaires	\$2,063.40	\$2,063.40
9 – 17,000 Lumens, 4000K Luminaires	\$1,042.20	\$1,042.20
19 - Concrete Poles	\$1,881.00	\$1,881.00
3420 Ft. – Underground Wiring	\$2,317.49	\$2,317.49
Annual Fuel Adjustments (Based on 13,824 KWH at \$0.03459 per KWH)	\$478.17	\$478.17
Franchise Cost (Based on 6.00% of \$7,782.26)	\$466.94	\$466.94
FPL Restoration Costs	\$5,700.00	\$0.00
FPL Additional Lighting Charge (ALC) Costs	\$252.00	\$252.00
FPL Boring Costs	\$15,390.00	\$0.00
Contingencies	<u>\$5,918.24</u>	<u>\$765.11</u>
Subtotal Street Lighting Services Costs	\$35,509.44	\$9,266.31
Engineering and Administrative Costs	\$9,292.86	\$292.86
Billing, Collecting and Processing Costs	<u>\$4,594.05</u>	<u>\$0.00</u>
Street Lighting Costs Paid by Petitioner	\$49,396.35	
Total Annual Street Lighting Costs		\$9,559.17
 <u>Estimated Annual District Assessments</u>	 <u>First Year</u>	 <u>Second Year</u>
Per Assessable Front Foot:	Costs to be	\$1.9788
For a Typical Lot:	Provided by	\$40.80
	Petitioner	

<u>Estimated Combined Annual District Assessments</u>	<u>First Year</u>	<u>Second Year</u>
For a Typical Lot:	Costs to be Provided by Petitioner	\$1,380.86

4. **CONFORMITY TO THE MASTER PLAN OF MIAMI-DADE COUNTY**

The proposed Special Taxing District conforms to and in no way conflicts with the master plan of development for the County (see attached memorandum from the Department of Regulatory and Economic Resources (RER)).

5. **RECOMMENDATION CONCERNING THE DESIRABILITY OF THIS DISTRICT**

The need for multipurpose maintenance programs and street lighting in the County is apparent. Residents and property owners of the County continue to demonstrate their desire for the services which will be provided by this Special Taxing District through numerous petitions and personal requests. The ability of the affected properties to pay special assessments is evident since the costs of this Special Taxing District's services, including any bonds then outstanding, do not exceed 25% of the assessed valuation of all properties within the Special Taxing District's boundaries (including homesteads) as shown by the last preceding assessment roll of the County. In my opinion, the proposed multipurpose maintenance and streetlight program will provide special benefits to properties within the Special Taxing District exceeding the amount of special assessments to be levied.

6. **PROCEDURE**

Following the creation of the Special Taxing District by the Board of County Commissioners (Board), the petitioner's plat shall not be placed on a Commission agenda for approval prior to receipt of the payment from the petitioner for the first-year street lighting costs as specified above. Upon approval of the petitioner's plat by the Board, and at the time-of-service provision, the multipurpose maintenance lot or parcel square footage first year annual rate of the assessment shall be determined and will require the adoption of a multipurpose maintenance assessment roll by the Board and is predicated upon failure of any association or CDD to provide required maintenance services. The multipurpose maintenance square footage rate of the assessment for the second year and each year thereafter will then be adjusted annually based on actual expenses. The above annual costs and assessment information for multipurpose maintenance services are for report purposes only and were calculated based on current costs assuming that maintenance services were to commence this year.

Subsequently, and upon adoption of the petitioner's plat by the Board, the County may then enter into an agreement with FPL in substantially the form attached herein, wherein the County will pay to FPL any costs associated with the streetlight installation and ongoing costs of service. Based on front footage, each property owner within the proposed Special Taxing District will pay the County, through a special assessment, a proportionate share of the total annual costs for the second year and each year thereafter. In the event actual second year street lighting costs are lower than the costs estimated herein, the Director of PROS shall adjust and decrease the second-year rate of the assessment. In the event actual second year street lighting costs are higher than estimated herein, the second-year rate of the assessment shall not be increased prior to the Board adopting a revised street lighting assessment roll.

A) Multipurpose Maintenance Services - Contingent upon adoption of the petitioner's plat and multipurpose maintenance assessment roll by the Board, and prior to assumption of maintenance services by the County, all areas and facilities to be maintained by the Special Taxing District must be inspected and accepted by the County, and all instruments that convey title to, or provide ingress/egress over, any real property to be maintained by the County shall be submitted to the Special Assessment

Districts Division of PROS. Maintenance of any lake, natural preservation area, archeological sites, and mitigation area within the Special Taxing District's boundaries to be maintained by the Special Taxing District will commence upon notice from RER that the developer has complied with any and all maintenance requirements imposed by RER.

Once any applicable provisions expressed above are met, implementation of maintenance services within or abutting the public rights-of-way may begin upon receipt of a written request from the developer no later than January 31st for services commencing October 1st, the beginning of the County's fiscal year, provided sufficient time to initiate the process of assessment and notice of collection to all property owners within the Special Taxing District.

Services within the private road areas may commence upon failure of the developer or any association or CDD to maintain the landscaped areas and ingress/egress easements as defined in a "Grant of Perpetual Non-Exclusive Easement" and made a part herein by reference. Upon assumption of maintenance services by the Special Taxing District, the costs of which are estimated in the Special Taxing District's cost estimate, any increase in future multipurpose maintenance functions within the scope of service for the Special Taxing District may be provided upon recommendation by a majority of the property owners for consideration by the County as administrator, provided that any expansion of the scope of service of the Special Taxing District may require adoption of an amending ordinance. The Special Taxing District shall provide a minimum level of service as determined by PROS and services may not be deleted entirely unless the Special Taxing District is abolished.

However, because costs and/or maintenance service levels may increase, the estimated annual expense, as indicated herein, can only be based on the initial maintenance program. After the first year, the costs of the multipurpose maintenance program will therefore require adjustment annually through the budget process performed by PROS as administrator of the Special Taxing District.

B) Street Lighting Services - As provided for under Chapter 18 of the Code, the property owners or developers within the proposed Special Taxing District shall guarantee payment of all costs and expenses incidental to the creation of the Special Taxing District and shall pay the entire cost of providing street lighting within the Special Taxing District for the first year. Upon adoption of the petitioner's plat by the Board, FPL will install the lights, poles and service lines at its expense, with annual service/rental costs to be borne by the Special Taxing District's property owners. The County may then enter into an agreement with FPL wherein the County will pay to FPL any costs associated with the streetlight installation, and for the annual costs of providing the streetlight services. These amounts will be charged during the first year's operation against funds advanced by the petitioners. Based on front footage, each property owner within the proposed Special Taxing District will pay the County, through a special assessment, a proportionate share of the total annual street lighting costs each year thereafter.

7. RECOMMENDATION

I recommend that Acacia Groves Multipurpose Maintenance and Street Lighting Special Taxing District be created pursuant to section 18-2 of the Code, which provides for the creation of special taxing districts for street lighting in new subdivisions and section 18-22.1 permitting a petition of all property owners for multipurpose maintenance services. The creation of this Special Taxing District will be subject to Board approval; no election will be necessary as 100% of the property owners signed the petition. I also recommend that the County Attorney cause to be prepared an ordinance authorizing the creation of the Acacia Groves Multipurpose Maintenance and Street Lighting Special Taxing District. Pursuant to Chapter 18 of the Code, the Board shall receive and hear, at a public hearing, remarks by interested persons on this Special Taxing District, and thereafter may adopt such ordinance. Following adoption of the creating ordinance, it is further recommended that the Board adopt the Special Taxing

District's Preliminary Assessment Roll(s) Resolution. Adoption of this resolution will enable the Miami-Dade County Tax Collector to collect the funds necessary to administer the Special Taxing District, reimburse affected County Departments involved in the creation and establishment of the Special Taxing District, as well as provide funds for payment of the annual costs for the multipurpose maintenance services and the Special Taxing District's monthly power bills for the second year and each year thereafter. The ordinance creating the Special Taxing District shall take effect 10 days after the date of its adoption, unless vetoed by the Mayor, and if vetoed, it shall become effective only upon an override by the Board. My office will also be available to answer any questions from the public or your office in regard to the financial and/or engineering facts of this Special Taxing District. We further recommend that the County Mayor or County Mayor's designee forward the attached report to the Board after review and concurrence with our findings.

- Attachments:
- (1) Copy of Petition and Attachments
 - (2) Copy of FPL Rate Schedule No. LT-1
 - (3) Copy of FPL Street Lighting Agreement Form
 - (4) Copy of Memo from Department of Regulatory and Economic Resources
 - (5) District Boundaries and Geographical Location Sketch (Exhibit A)

Memorandum



Date: 8/1/2025

To: Basia Pruna, Deputy Clerk
Office of the Clerk of the Board
Attn: Shania Momplaisir

From: *LRL*
Liset Romero-Lopez, Chief
Special Assessment Districts Division
Parks, Recreation and Open Spaces Department

Subject: Acacia Groves Multipurpose Maintenance and Street Lighting Special Taxing District

In reference to the subject petition, we hereby certify that, in compliance with Sections 18-2 and 18-22.1 of the Miami-Dade County Code, this Department has verified the attached name against the records of the Office of the Property Appraiser and has concluded that said petition relates to real property in a new subdivision and the signator is an owner and/or individual signing in his official capacity as representative of the owner of the property in question. We are therefore submitting the following information:

1.	Total number of parcels of land within district boundaries	<u>1</u>
2.	Total number of owners of property within district boundaries	<u>1</u>
3.	Total number of resident owners within district boundaries (this is a new subdivision area)	<u>0</u>
4.	Total number of signatures on the petition	<u>1</u>
5.	Total number of owners or representatives signing the petition in an official capacity	<u>1</u>
6.	Percentage of owners or representatives signing the petition in their official capacity	<u>100%</u>

Pursuant to Sections 18-2 and 18-22.1 of the Code, this is a valid petition.

By copy of this memorandum, I am forwarding this petition for review by the County Attorney for legal sufficiency.

Attachment

c: Ryan Carlin

**MIAMI-DADE COUNTY
PARKS, RECREATION AND OPEN SPACES DEPARTMENT
SPECIAL ASSESSMENT DISTRICTS DIVISION**

March 17, 2025
Document Preparation Date

Departmental Acceptance Date
(Government Use Only)

PETITION FOR MULTIPURPOSE AND STREET LIGHTING SPECIAL TAXING DISTRICT

To the Board of County Commissioners of Miami-Dade County, Florida:

We, the undersigned property owners, do hereby petition Miami-Dade County, Florida, for the creation of the Special Taxing District(s) required by the respective plat(s) pursuant to Chapter 18 of the Code of Miami-Dade County, Florida, for any or all of the following: installation, operation and maintenance of Light Emitting Diode (LED) of an intensity of 5,000 up to 50,000 lumens, mounted on concrete, fiber glass or existing poles; landscape, lake, entrance features and wall maintenance services (requested landscape, lake, entrance features and wall maintenance services shall be more fully described on the attached Exhibit B). The petitioned for district lies within that portion of the unincorporated area of Miami-Dade County more fully described on the attached Exhibit A.

Tentative Plat(s) Name(s) ACACIA GROVES (T-25070)

It is understood and agreed that the boundaries of this district and the type and level of services to be provided by this district will be reviewed by the appropriate County authorities. It is also understood that the streetlights and other improvements to be provided shall be in accordance with minimum standards and requirements set forth by the Miami-Dade County Parks, Recreation and Open Spaces Department.

OWNER'S NAME	OWNER'S ADDRESS	LEGAL DESCRIPTION OF PROPERTY	TAX FOLIO NUMBER
TPG AG EHC III (LEN) MULTI STATE 2, LLC, A DELAWARE LIMITED LIABILITY COMPANY BY: ESSENTIAL HOUSING ASSET MANAGEMENT LLC, AN ARIZONA LIMITED LIABILITY COMPANY, AS ITS AUTHORIZED AGENT BY: _____ NAME: Steven S. Benson TITLE: Manager	c/o Lennar Homes, LLC 5505 Blue Lagoon Drive, 5th Floor Miami, FL 33126	MORE FULLY DESCRIBED ON THE ATTACHED "EXHIBIT A"	30-7823-000-0200

STATE OF ARIZONA
COUNTY OF MARICOPA

I HEREBY CERTIFY that on this day, an officer duly authorized to take acknowledgements, personally appeared before me, by physical presence -OR- Online Notarization, Steven S. Benson, as manager of Essential Housing Asset Management LLC, an Arizona limited liability company, the Authorized Agent of TPG AG EHC III (LEN) MULTI STATE 2, LLC, a Delaware limited liability company, personally known to me, or who produced identification in the form of _____, and who executed the same for the purposes herein expressed.

WITNESS my hand and official seal in the County and State last aforesaid, this 2 day of April, 2025.

[SEAL]

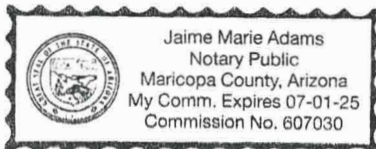

Notary Public State of Arizona: Jaime Marie Adams
 Print Name: Jaime Marie Adams
 My Commission expires: 07/01/2025

EXHIBIT "A"

EXHIBIT "A" TO THE PETITION FOR THE PLAT KNOWN AS ACACIA GROVES DATED MARCH 17, 2025, FOR THE CREATION OF A STREET LIGHTING AND MULTIPURPOSE MAINTENANCE SPECIAL TAXING DISTRICT.

LEGAL DESCRIPTION:

THE NORTHWEST 1/4 OF THE SOUTHWEST 1/4 OF SECTION 23, TOWNSHIP 57 SOUTH, RANGE 38 EAST, MIAMI-DADE COUNTY, FLORIDA, LESS THE NORTH 35 FEET AND THE WEST 35 FEET OF SAID TRACT; SAID LAND LYING AND BEING IN MIAMI-DADE COUNTY, FLORIDA.

ALSO KNOWN AS:

COMMENCE AT THE NORTHWEST CORNER OF THE NORTHWEST ONE QUARTER (1/4) OF THE SOUTHWEST ONE QUARTER OF SECTION 23, TOWNSHIP 57 SOUTH, RANGE 38 EAST, MIAMI-DADE COUNTY, FLORIDA; ALSO BEING THE WEST ONE QUARTER (1/4) CORNER OF SAID SECTION 23, TOWNSHIP 57 SOUTH, RANGE 38 EAST, MIAMI-DADE COUNTY, FLORIDA; THENCE RUN ALONG THE NORTH LINE OF THE SOUTHWEST ONE QUARTER (1/4) OF SAID SECTION 23, NORTH 89°18'22" EAST FOR A DISTANCE OF 1333.19 FEET TO THE NORTHEAST CORNER OF THE NORTHWEST ONE QUARTER (1/4) OF THE SOUTHWEST ONE QUARTER (1/4) OF SAID SECTION 23; THE NEXT TWO DESCRIBED COURSES BEING ALONG THE EAST LINE OF THE NORTHWEST ONE QUARTER (1/4) OF THE SOUTHWEST ONE QUARTER (1/4) OF SAID SECTION 23; THENCE SOUTH 00°23'22" EAST FOR 35.00 FEET TO THE POINT OF BEGINNING OF THE FOLLOWING DESCRIBED PARCEL; THENCE CONTINUE SOUTH 00°23'22" EAST FOR 1298.92 FEET TO THE SOUTH EAST CORNER OF THE NORTHWEST ONE QUARTER (1/4) OF THE SOUTHWEST ONE QUARTER OF SAID SECTION 23;

DEPARTMENTAL ACCEPTANCE DATE
(GOVERNMENT USE ONLY)

THENCE RUN ALONG THE SOUTH LINE OF THE NORTHWEST ONE QUARTER (1/4) OF THE SOUTHWEST ONE QUARTER OF SAID SECTION 23, SOUTH 89°30'47" WEST FOR A DISTANCE OF 1293.65 FEET; THENCE RUN ALONG A LINE PARALLEL WITH AND 35.00 FEET EASTERLY OF, AS MEASURED AT RIGHT ANGLES TO, THE WEST LINE OF THE SOUTHWEST ONE QUARTER (1/4) OF SAID SECTION 23, NORTH 00°35'04" WEST FOR A DISTANCE OF 1294.24 FEET TO A POINT; THENCE RUN ALONG A LINE PARALLEL WITH AND 35.00 FEET SOUTHERLY OF, AS MEASURED AT RIGHT ANGLES TO, THE NORTH LINE OF THE SOUTHWEST ONE QUARTER (1/4) OF SAID SECTION 23, NORTH 89°18'22" EAST FOR A DISTANCE 1298.08 FEET TO THE POINT OF BEGINNING, CONTAINING 1,680,179 SQUARE FEET MORE OR LESS, OR 38.572 ACRES MORE OR LESS.

Folio: 30-7823-000-0200.

EXHIBIT B

EXHIBIT “B” TO THE PETITION FOR THE SUBDIVISION KNOWN AS **ACACIA GROVES (T-25070)**, DATED MARCH 17, 2025, FOR THE CREATION OF STREET LIGHTING AND MULTIPURPOSE MAINTENANCE SPECIAL TAXING DISTRICT.

AREAS TO BE MAINTAINED:

WITHIN THE PUBLIC RIGHT-OF-WAY:

- OPEN SPACE LANDSCAPED AREAS
- BERMS AND LANDSCAPING ALONG SW 194TH AVENUE, SW 197TH AVENUE, SW 336TH STREET AND SW 340TH STREET

WITHIN THE PRIVATE ROAD COMMUNITY:

- OPEN SPACE LANDSCAPED AREAS, PRIVATE ROADS

MAINTENANCE SCHEDULE:

A.) LAWN/GRASS

- 1) CUT AS REQUIRED
- 2) FERTILIZE AND WEED CONTROL AS NEEDED
- 3) TREAT FOR PESTS/DISEASES AS NEEDED
- 4) IRRIGATE WITH AUTOMATIC SYSTEM AND ELECTRICAL SERVICE FOR SAME
- 5) MULCHING – PERFORMED TWICE A YEAR OR AS NEEDED

B.) TREES/SHRUBS

- 1) TRIM, FERTILIZE AND TREAT FOR PESTS AS NEEDED
- 2) REPLACE AS REQUIRED

Note: THIS SPECIAL TAXING DISTRICT ENCOMPASSES A PRIVATE DRIVE COMMUNITY AND THE MULTIPURPOSE MAINTENANCE COMPONENT OF THE DISTRICT SHALL BE **DORMANT**. SERVICE WILL ONLY COMMENCE FOLLOWING FAILURE (AS DEFINED IN A “GRANT OF PERPETUAL NON-EXCLUSIVE EASEMENT” SUBMITTED AT THE SAME TIME AS THIS PETITION) OF ANY HOME-OWNER’S ASSOCIATION AND/OR COMMUNITY DEVELOPMENT DISTRICT TO PROVIDE THE REQUIRED SERVICES. ASSUMPTION OF MAINTENANCE SERVICES SHALL COMMENCE FOLLOWING ADOPTION OF THIS DISTRICT’S MULTIPURPOSE MAINTENANCE ASSESSMENT ROLL BY THE BOARD OF COUNTY COMMISSIONERS AT A PUBLIC HEARING. OTHER MAINTENANCE SERVICES MAY BE PROVIDED IN THE FUTURE AS SPECIFIED IN THE

DISTRICT'S ORDINANCE AND AMENDMENTS THERETO. IN THE EVENT THIS DISTRICT IS ACTIVATED, THE FOLLOWING AREAS MAY BE MAINTAINED:

- OPEN SPACE LANDSCAPED AREAS, PRIVATE ROADS

ROAD MAINTENANCE INCLUDES INFRASTRUCTURE REPAIR UPON ACTIVATION OF THE DORMANT MULTIPURPOSE DISTRICT.

LIGHTINGRATE SCHEDULE: LT-1AVAILABLE:

In all areas served.

APPLICATION:

For the purpose of lighting streets and roadways, area lighting including parking lots and common areas, whether public or privately owned, and outdoor lighting.

TYPE OF INSTALLATION:

All new installations will be light emitting diodes (LED). Company-owned fixtures normally will be mounted on poles of the Company's existing distribution system and served from overhead wires. For roadway and area lighting, excluding outdoor lighting, the Company may provide special poles or underground wires at the charges specified below. In addition, the Company, at its discretion, may offer the Customer the option of Company-owned fixtures attached to poles owned by the Customer. For these installations, the customer owned poles require pre-approval by a Company representative.

Outdoor lights can only be mounted on accessible existing distribution poles facing the customer's property.

The location and the type of the facilities are, and will continue to be, easily and economically accessible to the Company equipment and personnel for both construction and maintenance.

SERVICE:

Service includes energy from dusk each day until dawn the following day and maintenance of Company-owned lighting systems. Maintenance includes replacement or repair of any circuit component to assure the facilities are operational and safe. The Company will maintain its facilities during regular daytime working hours as soon as practicable following notification by the Customer that such work is necessary. The Company shall be permitted to enter the Customer's premises at all reasonable times for the purpose of inspecting, maintaining, installing and removing any or all of its equipment and facilities.

The Company, while exercising reasonable diligence at all times to furnish service hereunder, does not guarantee continuous lighting and will not be liable for damages for any interruption, deficiency or failure of service, and reserves the right to interrupt service at any time for necessary repairs to lines or equipment.

LIMITATION OF SERVICE:

Installation shall be made only when, in the judgement of the Company, the location and the type of the facilities are, and will continue to be, easily and economically accessible to the Company equipment and personnel for both construction and maintenance. Overhead conductors will not be installed in any area designated as an underground distribution area, or any area, premises or location served from an underground source.

For outdoor lights, customer must have an active house or premise account associated with this service.

Stand-by or resale service is not permitted hereunder.

CUSTOMER CONTRIBUTIONS:

A Contribution-in-Aid-of-Construction (CIAC) will be required for:

- a) the differential cost between employing rapid construction techniques in trenching, backfilling and pole installation work where no obstructions exist, and the added cost to overcome obstructions such as sprinkler systems, paved surfaces (such as sidewalks, curbs, gutters, and roadways), landscaping, sodding and other obstructions encountered along the Lighting System installation route, including repair and replacement. If the Customer elects to perform work such as trenching and restoration, they will be reimbursed by the Company with a credit (not to exceed the total CIAC cost) for the value of this work as determined by the Company;
- b) the installation cost of any new overhead distribution facilities and/or the cost of alterations to existing distribution facilities which are required in order to serve the Lighting System less four (4) times the additional annual non-fuel energy revenue generated by the installation or alteration of the Lighting System, plus where underground facilities are installed, the differential installation cost between underground and overhead distribution facilities.

These costs shall be paid by the Customer prior to the initiation of any construction work by the Company. The Customer shall also pay any additional costs associated with design modifications requested after the original estimate has been made.

REMOVAL OR RELOCATION OF FACILITIES:

If Company owned lighting facilities are removed by Customer request, breach of the Agreement or non-payment, the Customer may be responsible to pay the net book value for the fixtures, poles, and additional lighting facility charges plus the cost to remove the facilities. These charges do not apply to conversions of Company owned non-LED to Company owned LED lights.

When the Company relocates or removes its facilities to comply with governmental requirements, either the Company or the Customer shall have the right, upon written notice, to discontinue service hereunder without obligation or liability.

Facility relocations are treated as removals of facilities from the old location and installation of the new facilities in the new location. Facilities will not be transferred and reused at a new location.

In all cases, should the Customer request termination of the Agreement, such termination will require written notice 90 days prior to the date of termination.

CONVERSION OF COMPANY OWNED NON-LED LIGHTS TO COMPANY OWNED LED LIGHTS:

For customers converting, Company owned non-LED to Company owned LED Lights, the LED Conversion Recovery Charge will apply and there will be no charge for the fixtures being removed. Any other charges for relocation or replacement of Company owned facilities would still apply.

CHANGE IN FIXTURE SIZE OR TYPE:

At the Customer's request, the Company will change to a lower or higher level of illumination when the changes are consistent with good engineering practices. A LED fixture will be the only modification from an LED or non-LED fixture request. The Customer will pay the net book value of the existing fixture, plus removal costs and will receive a credit for 4 years additional revenue generated by the larger fixtures, if applicable. If changes are required to the distribution system to support the larger lights, standard CIAC charges as described on sheet 8.736 will also apply. The Customer will pay the Company the net costs incurred in making other fixture changes.

(Continued from Sheet No. 8.735.1)

MONTHLY RATES FOR MAINTENANCE AND CONVERSION:

Maintenance per Fixture (FPL Owned Fixture and Pole)	\$1.47
Maintenance per Fixture for FPL fixtures on Customer Pole	\$1.18
LED Conversion Recovery	\$2.11

MONTHLY RATES FOR POLES USED ONLY FOR LIGHTING SYSTEM:

Standard Wood pole	\$6.03
Standard Concrete pole	\$8.25
Standard Fiberglass pole	\$9.74
Decorative Concrete pole	\$17.71

MONTHLY RATES FOR LED FIXTURES*:

Energy Tier	Charge	Fixture Tier														
		1	2	3	4	5	6	7	8	9	10	11	12	13	14	15
A	\$ -	1.50	4.50	7.50	10.50	13.50	16.50	19.50	22.50	25.50	28.50	31.50	34.50	37.50	40.50	43.50
B	\$ 0.20	1.70	4.70	7.70	10.70	13.70	16.70	19.70	22.70	25.70	28.70	31.70	34.70	37.70	40.70	43.70
C	\$ 0.40	1.90	4.90	7.90	10.90	13.90	16.90	19.90	22.90	25.90	28.90	31.90	34.90	37.90	40.90	43.90
D	\$ 0.60	2.10	5.10	8.10	11.10	14.10	17.10	20.10	23.10	26.10	29.10	32.10	35.10	38.10	41.10	44.10
E	\$ 0.80	2.30	5.30	8.30	11.30	14.30	17.30	20.30	23.30	26.30	29.30	32.30	35.30	38.30	41.30	44.30
F	\$ 1.00	2.50	5.50	8.50	11.50	14.50	17.50	20.50	23.50	26.50	29.50	32.50	35.50	38.50	41.50	44.50
G	\$ 1.20	2.70	5.70	8.70	11.70	14.70	17.70	20.70	23.70	26.70	29.70	32.70	35.70	38.70	41.70	44.70
H	\$ 1.40	2.90	5.90	8.90	11.90	14.90	17.90	20.90	23.90	26.90	29.90	32.90	35.90	38.90	41.90	44.90
I	\$ 1.60	3.10	6.10	9.10	12.10	15.10	18.10	21.10	24.10	27.10	30.10	33.10	36.10	39.10	42.10	45.10
J	\$ 1.80	3.30	6.30	9.30	12.30	15.30	18.30	21.30	24.30	27.30	30.30	33.30	36.30	39.30	42.30	45.30
K	\$ 2.00	3.50	6.50	9.50	12.50	15.50	18.50	21.50	24.50	27.50	30.50	33.50	36.50	39.50	42.50	45.50
L	\$ 2.20	3.70	6.70	9.70	12.70	15.70	18.70	21.70	24.70	27.70	30.70	33.70	36.70	39.70	42.70	45.70
M	\$ 2.40	3.90	6.90	9.90	12.90	15.90	18.90	21.90	24.90	27.90	30.90	33.90	36.90	39.90	42.90	45.90
N	\$ 2.60	4.10	7.10	10.10	13.10	16.10	19.10	22.10	25.10	28.10	31.10	34.10	37.10	40.10	43.10	46.10
O	\$ 2.80	4.30	7.30	10.30	13.30	16.30	19.30	22.30	25.30	28.30	31.30	34.30	37.30	40.30	43.30	46.30
P	\$ 3.00	4.50	7.50	10.50	13.50	16.50	19.50	22.50	25.50	28.50	31.50	34.50	37.50	40.50	43.50	46.50
Q	\$ 3.20	4.70	7.70	10.70	13.70	16.70	19.70	22.70	25.70	28.70	31.70	34.70	37.70	40.70	43.70	46.70
R	\$ 3.40	4.90	7.90	10.90	13.90	16.90	19.90	22.90	25.90	28.90	31.90	34.90	37.90	40.90	43.90	46.90
S	\$ 3.60	5.10	8.10	11.10	14.10	17.10	20.10	23.10	26.10	29.10	32.10	35.10	38.10	41.10	44.10	47.10
T	\$ 3.80	5.30	8.30	11.30	14.30	17.30	20.30	23.30	26.30	29.30	32.30	35.30	38.30	41.30	44.30	47.30
U	\$ 4.00	5.50	8.50	11.50	14.50	17.50	20.50	23.50	26.50	29.50	32.50	35.50	38.50	41.50	44.50	47.50
V	\$ 4.20	5.70	8.70	11.70	14.70	17.70	20.70	23.70	26.70	29.70	32.70	35.70	38.70	41.70	44.70	47.70
W	\$ 4.40	5.90	8.90	11.90	14.90	17.90	20.90	23.90	26.90	29.90	32.90	35.90	38.90	41.90	44.90	47.90
X	\$ 4.60	6.10	9.10	12.10	15.10	18.10	21.10	24.10	27.10	30.10	33.10	36.10	39.10	42.10	45.10	48.10
Y	\$ 4.80	6.30	9.30	12.30	15.30	18.30	21.30	24.30	27.30	30.30	33.30	36.30	39.30	42.30	45.30	48.30
Z	\$ 5.00	6.50	9.50	12.50	15.50	18.50	21.50	24.50	27.50	30.50	33.50	36.50	39.50	42.50	45.50	48.50
AA	\$ 5.20	6.70	9.70	12.70	15.70	18.70	21.70	24.70	27.70	30.70	33.70	36.70	39.70	42.70	45.70	48.70
BB	\$ 5.40	6.90	9.90	12.90	15.90	18.90	21.90	24.90	27.90	30.90	33.90	36.90	39.90	42.90	45.90	48.90
CC	\$ 5.60	7.10	10.10	13.10	16.10	19.10	22.10	25.10	28.10	31.10	34.10	37.10	40.10	43.10	46.10	49.10
DD	\$ 5.80	7.30	10.30	13.30	16.30	19.30	22.30	25.30	28.30	31.30	34.30	37.30	40.30	43.30	46.30	49.30
EE	\$ 6.00	7.50	10.50	13.50	16.50	19.50	22.50	25.50	28.50	31.50	34.50	37.50	40.50	43.50	46.50	49.50

* Catalog of available fixtures and the assigned billing tier for each can be viewed at www.FPL.com/partner/builders/lighting.html

The non-fuel energy charge is 3.459¢ per kWh; where the kWh is calculated as (wattage x 353.3 hours per month)/ 1000

SPECIAL PROVISIONS:

Where the Company provides fixtures or poles other than those referenced above, the monthly charges, as applicable shall be computed as follows:

Charge: 1.28% of the Company's average installed cost of the pole, light fixture, or both.

Standard maintenance fees to apply
Standard non-fuel Energy Charge to apply

ADDITIONAL LIGHTING CHARGE:

Any special or additional lighting charges, which are required by the Company, will be billed in addition to the above rates.

Charge: 1.28% of the Company's average installed cost of the additional lighting facilities.

As of January 1, 2022, the factor pertaining to Underground Conductor will be closed to new customers.
Underground Conductor 4.935¢ per foot

BILLING

During the initial installation period:

- Facilities in service for 15 days or less will not be billed;
- Facilities in service for 16 days or more will be billed for a full month.

For outdoor lights only, the Company has the right at any time to remove the light for non-payment and decline new request to customers with prior non-payment activity.

WILLFUL DAMAGE:

Upon the second occurrence of willful damage to any Company-owned facilities, the Customer will be responsible for the cost incurred for repair or replacement. If the lighting fixture is damaged, based on prior written instructions from the Customer, the Company will:

- a) If a commercially available and Company approved device exists, install a protective shield. The Customer shall pay \$280.00 for the shield plus all associated costs. However, if the Customer chooses to have the shield installed before the second occurrence, the Customer shall only pay the cost of the shield; or
- b) Replace with a like unshielded fixture. For this, and each subsequent occurrence, the Customer shall pay the estimated costs of the replacement fixture; or
- c) Terminate service to the fixture. In this case, the lighting facilities will be removed from the field and from billing; the Customer will pay the lighting facilities charges for the remaining period of the currently active term of service plus the cost to remove the facilities.

Option selection shall be made by the Customer in writing and apply to all fixtures which the Company has installed on the Customer's behalf on the same account. Selection changes may be made by the Customer at any time and will become effective ninety (90) days after written notice is received.

(Continued on Sheet No. 8.738)

(Continued from Sheet No. 8.737)

OTHER CHARGES

See Billing Adjustments section, Sheet No. 8.030, for additional applicable charges.

SPECIAL CONDITIONS:

Customers whose lights are turned off during sea turtle nesting season will receive a credit equal to the non-fuel charges associated with the fixtures that are turned off.

TERM OF SERVICE:

Service for outdoor lighting will be established for a minimum of one (1) year unless terminated by either the Company or the Customer.

All other services, besides outdoor lighting mentioned above, will require a Lighting Agreement.

Lighting agreements will have an initial term of ten (10) years with automatic, successive five (5) year extensions unless renegotiated or terminated in writing by either the Company or the Customer at least ninety (90) days prior to the current term's expiration. In the event of the sale of the real estate property upon which the facilities are installed, upon the written consent of the Company, the contract may be assigned by the Customer to the Purchaser. No assignment shall not relieve the Customer from its obligations hereunder until such obligations have been assumed by the assignee and agreed to by the Company.

Term of service begins upon execution of the Lighting Agreement.

All governmental or commercial / industrial customer contracts to be executed by property owner or governing body.

All existing contract terms prior to January 1, 2022 will be honored.

RULES AND REGULATIONS:

Service under this schedule is subject to orders of governmental bodies having jurisdiction and to the currently effective "General Rules and Regulations for Electric Service" on file with the Florida Public Service Commission. In case of conflict between any provision of this schedule and said, "General Rules and Regulations for Electric Service", the provision of this schedule shall apply.

FPL Account Number: _____

FPL Work Request Number: _____

LIGHTING AGREEMENT

In accordance with the following terms and conditions, _____ (hereinafter called the Customer), requests on this day of _____, _____, from FLORIDA POWER & LIGHT COMPANY (hereinafter called FPL), a corporation organized and existing under the laws of the State of Florida, the following installation or modification of lighting facilities at (general boundaries) _____, located in _____, Florida.

(a) Installation and/or removal of FPL-owned facilities described as follows:

Fixture Description ⁽¹⁾	Watts	Lumens	Color Temperature	# Installed	# Removed

(1) Catalog of available fixtures and the assigned billing tier for each can be viewed at www.fpl.com/led

(Continued on Sheet No. 9.141)

(Continue from Sheet No.9.141)

That, for and in consideration of the covenants set forth herein, the parties hereto covenant and agree as follows:

FPL AGREES:

1. To install or modify the lighting facilities described and identified above (hereinafter called the Lighting System), furnish to the Customer the electric energy necessary for the operation of the Lighting System, and furnish such other services as are specified in this Agreement, all in accordance with the terms of FPL's currently effective lighting rate schedule on file at the Florida Public Service Commission (FPSC) or any successive lighting rate schedule approved by the FPSC.

THE CUSTOMER AGREES:

2. To pay a monthly fee for fixtures and poles in accordance to the Lighting tariff, and additional lighting charge in the amount of \$_____. These charges may be adjusted subject to review and approval by the FPSC.
3. To pay Contribution in Aid of Construction (CIAC) in the amount of \$_____ prior to FPL's initiating the requested installation or modification.
4. To pay the monthly maintenance and energy charges in accordance to the Lighting tariff. These charges may be adjusted subject to review and approval by the FPSC.
5. To purchase from FPL all the electric energy used for the operation of the Lighting System.
6. To be responsible for paying, when due, all bills rendered by FPL pursuant to FPL's currently effective lighting rate schedule on file at the FPSC or any successive lighting rate schedule approved by the FPSC, for facilities and service provided in accordance with this agreement.
7. To provide access, suitable construction drawings showing the location of existing and proposed structures, and appropriate plats necessary for planning the design and completing the construction of FPL facilities associated with the Lighting System.
8. To have sole responsibility to ensure lighting, poles, luminaires and fixtures are in compliance with any applicable municipal or county ordinances governing the size, wattage, lumens or general aesthetics.
9. For new FPL-owned lighting systems, to provide final grading to specifications, perform any clearing if needed, compacting, removal of stumps or other obstructions that conflict with construction, identification of all non-FPL underground facilities within or near pole or trench locations, drainage of rights-of-way or good and sufficient easements required by FPL to accommodate the lighting facilities.
10. For FPL-owned fixtures on customer-owned systems:
 - a. To perform repairs or correct code violations on their existing lighting infrastructure. Notification to FPL is required once site is ready.
 - b. To repair or replace their electrical infrastructure in order to provide service to the Lighting System for daily operations or in a catastrophic event.
 - c. In the event the light is not operating correctly, Customer agrees to check voltage at the service point feeding the lighting circuit prior to submitting the request for FPL to repair the fixture.

IT IS MUTUALLY AGREED THAT:

11. Modifications to the facilities provided by FPL under this agreement, other than for maintenance, may only be made through the execution of an additional lighting agreement delineating the modifications to be accomplished. Modification of FPL lighting facilities is defined as the following:
 - a. the addition of lighting facilities;
 - b. the removal of lighting facilities; and
 - c. the removal of lighting facilities and the replacement of such facilities with new facilities and/or additional facilities.

Modifications will be subject to the costs identified in FPL's currently effective lighting rate schedule on file at the FPSC, or any successive schedule approved by the FPSC.

(Continue on Sheet No. 9.143)

(Continue on Sheet No. 9.142)

12. FPL will, at the request of the Customer, relocate the lighting facilities covered by this agreement, if provided sufficient rights-of-way or easements to do so and locations requested are consistent with clear zone right-of-way setback requirements. The Customer shall be responsible for the payment of all costs associated with any such Customer- requested relocation of FPL lighting facilities. Payment shall be made by the Customer in advance of any relocation.
Lighting facilities will only be installed in locations that meet all applicable clear zone right-of-way setback requirements.
13. FPL may, at any time, substitute for any fixture installed hereunder another equivalent fixture which shall be of similar illuminating capacity and efficiency.
14. This Agreement shall be for a term of ten (10) years from the date of initiation of service, and, except as provided below, shall extend thereafter for further successive periods of five (5) years from the expiration of the initial ten (10) year term or from the expiration of any extension thereof. The date of initiation of service shall be defined as the date the first lights are energized and billing begins, not the date of this Agreement. This Agreement shall be extended automatically beyond the initial the (10) year term or any extension thereof, unless either party shall have given written notice to the other of its desire to terminate this Agreement. The written notice shall be by certified mail and shall be given not less than ninety (90) days before the expiration of the initial ten (10) year term, or any extension thereof.
15. In the event lighting facilities covered by this agreement are removed, either at the request of the Customer or through termination or breach of this Agreement, the Customer shall be responsible for paying to FPL an amount equal to the original installed cost of the facilities provided by FPL under this agreement less any salvage value and any depreciation (based on current depreciation rates approved by the FPSC) plus removal cost.
16. Should the Customer fail to pay any bills due and rendered pursuant to this agreement or otherwise fail to perform the obligations contained in this Agreement, said obligations being material and going to the essence of this Agreement, FPL may cease to supply electric energy or service until the Customer has paid the bills due and rendered or has fully cured such other breach of this Agreement. Any failure of FPL to exercise its rights hereunder shall not be a waiver of its rights. It is understood, however, that such discontinuance of the supplying of electric energy or service shall not constitute a breach of this Agreement by FPL, nor shall it relieve the Customer of the obligation to perform any of the terms and conditions of this Agreement.
17. The obligation to furnish or purchase service shall be excused at any time that either party is prevented from complying with this Agreement by strikes, lockouts, fires, riots, acts of God, the public enemy, or by cause or causes not under the control of the party thus prevented from compliance, and FPL shall not have the obligation to furnish service if it is prevented from complying with this Agreement by reason of any partial, temporary or entire shut-down of service which, in the sole opinion of FPL, is reasonably necessary for the purpose of repairing or making more efficient all or any part of its generating or other electrical equipment.
18. This **Agreement supersedes all previous Agreements** or representations, either written, oral, or otherwise between the Customer and FPL, with respect to the facilities referenced herein and constitutes the entire Agreement between the parties. This Agreement does not create any rights or provide any remedies to third parties or create any additional duty, obligation or undertakings by FPL to third parties.
19. In the event of the sale of the real property upon which the facilities are installed, upon the written consent of FPL, this Agreement may be assigned by the Customer to the Purchaser. No assignment shall relieve the Customer from its obligations hereunder until such obligations have been assumed by the assignee and agreed to by FPL.
20. This Agreement shall inure to the benefit of and be binding upon the successors and assigns of the Customer and FPL.
21. The lighting facilities shall remain the property of FPL in perpetuity.
22. This Agreement is subject to FPL's Electric Tariff, including, but not limited to, the General Rules and Regulations for Electric Service and the Rules of the FPSC, as they are now written, or as they may be hereafter revised, amended or supplemented. In the event of any conflict between the terms of this Agreement and the provisions of the FPL Electric Tariff or the FPSC Rules, the provisions of the Electric Tariff and FPSC Rules shall control, as they are now written, or as they may be hereafter revised, amended or supplemented.

(Continue on Sheet No. 9.144)

IN WITNESS WHEREOF, the parties hereby caused this Agreement to be executed in triplicate by their duly authorized representatives to be effective as of the day and year first written above.

Changes and Terms Accepted:

Customer (Print or type name of Organization)

By: _____
Signature (Authorized Representative)

(Print or type name)

Title: _____

FLORIDA POWER & LIGHT COMPANY

By: _____
(Signature)

(Print or type name)

Title: _____

Memorandum



Date: October 18, 2024

To: Maria Nardi, Director
Department of Parks, Recreation and Open Spaces

From: *Jerry Bell*
Jerry Bell, AICP, Assistant Director for Planning
Department of Regulatory and Economic Resources

Subject: Street lighting, Maintenance of Landscape, Walls Adjacent to Double Frontage Lots, Entrance Features and Lakes – Special Taxing Districts

All tentative plats in the unincorporated area of Miami-Dade County submitted to the Development Services Division (Land Development Section) of the Regulatory and Economic Resources Department (RER), must comply with the special taxing districts requirements of the Miami-Dade County Code (the Code) including, but not limited to street lights, maintenance of landscape, walls adjacent to double frontage lots, entrance features and lakes. Final Plats will not be presented to the Board of County Commissioners for consideration until the applicable special taxing districts are created, and all fees have been paid. In that regard, to ensure expeditious processing, this Memorandum may serve, through September 30, 2025, as approval for certain future special taxing district application requests as being consistent with the intent and purpose of the adopted 2030-2040 Comprehensive Development Master Plan (CDMP). Capital Improvement Element Policy CIE-4A states: "Appropriate funding mechanisms will be adopted and applied by Miami-Dade County and the Miami-Dade County Public Schools in order to assure the fiscal resources to maintain acceptable levels of service. Such funding mechanisms may include special taxing districts, municipal taxing service units, local option taxes, user fees, local gas tax, general obligation bonds, impact fees, special purpose authorities, and others as appropriate and feasible" (Adopted Components as Amended through January 19, 2023, page IX-9). The provision for services over and above minimum standards required for neighborhoods and communities may be accomplished through special taxing districts as may be prescribed by the Code.

The RER has no objection to a blanket approval with condition to establish future special taxing districts as limited to requests for street lighting, landscape maintenance, walls adjacent to double frontage lots and lake maintenance districts. The previously noted special taxing districts may be established on the condition that the RER Development Services Division review all landscape maintenance districts and lake maintenance districts for consistency with Landscape Code (Chapter 18A) Section 18A-6(L) Storm Water Retention/Detention Areas.

JB:GR



DISTRICT BOUNDARIES

ACACIA GROVES

MULTIPURPOSE MAINTENANCE AND STREET LIGHTING SPECIAL TAXING DISTRICT

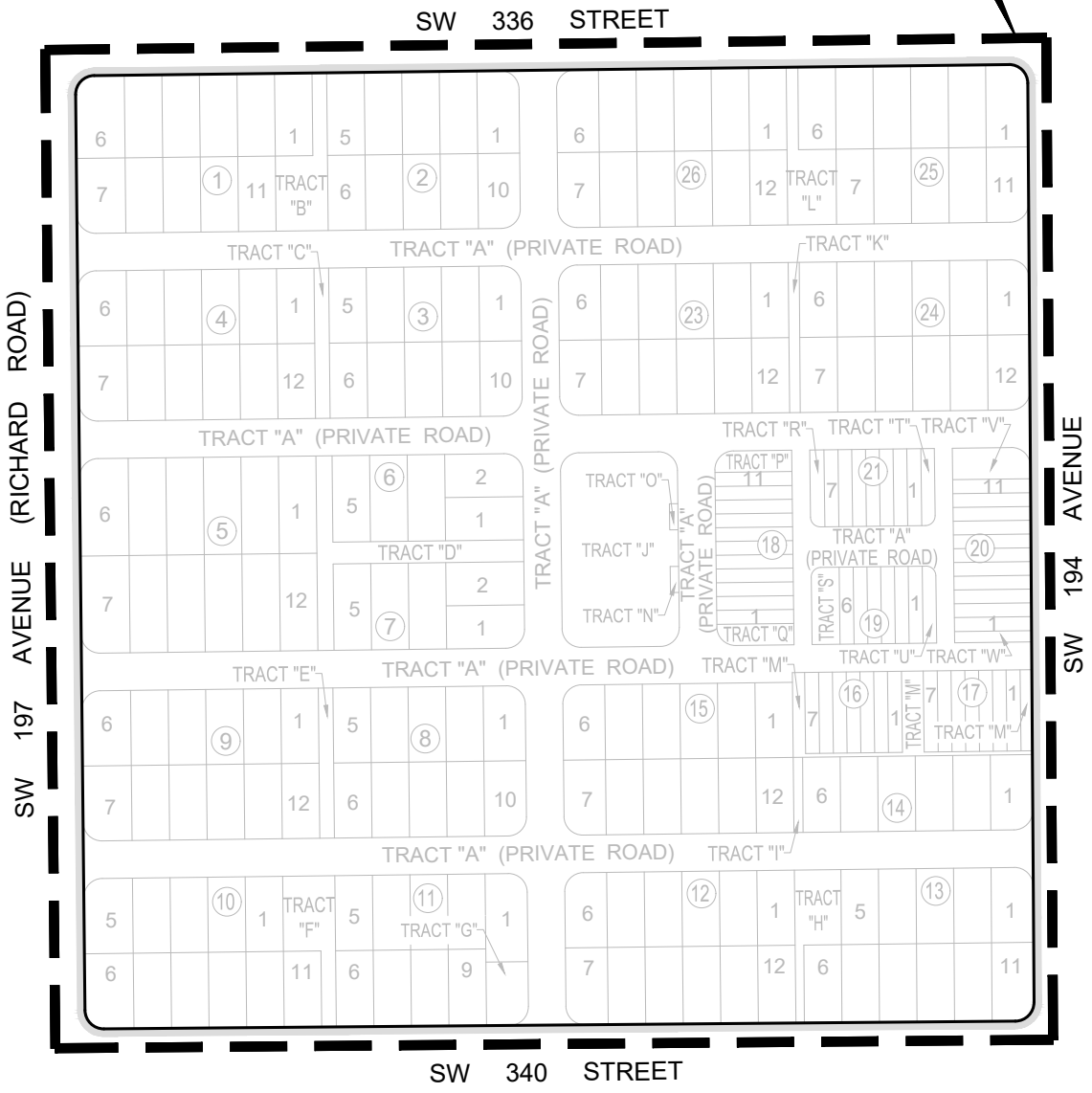

- 19 - ROADWAY (12,000 LUMENS / 92 WATTS, 3000K) LED BRACKET- ARM STREETLIGHTS MOUNTED ON NEW CONCRETE POLES.
- 9 - ROADWAY (17,000 LUMENS / 130 WATTS, 4000K) LED BRACKET- ARM STREETLIGHTS MOUNTED ON EXISTING CONCRETE POLES.

■ SHADING DENOTES AREAS TO BE MAINTAINED. SEE ATTACHED SHEET FOR SERVICE DESCRIPTIONS AND LOCATIONS.

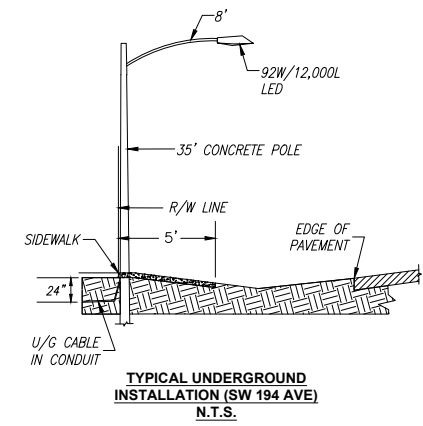
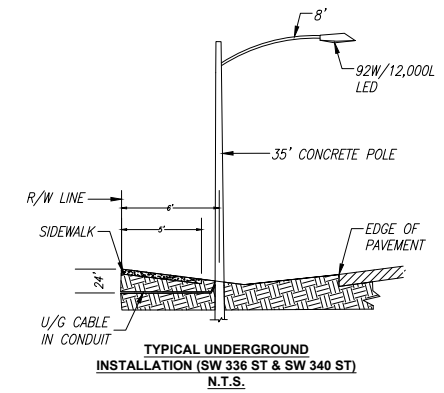

L-1550 / M-0925 (COMM. 0009)
SECTION: 23 - 57 - 38

EXHIBIT "A"
(BOUNDARIES & GEOGRAPHICAL LOCATION SKETCH)

MDC031

**ATTACHMENT TO EXHIBIT A
ACACIA GROVES MULTIPURPOSE MAINTENANCE
AND STREET LIGHTING SPECIAL TAXING DISTRICT**

AREAS TO BE MAINTAINED:

WITHIN THE PUBLIC RIGHT-OF-WAY:

- OPEN SPACE LANDSCAPED AREAS
- BERMS AND LANDSCAPING ALONG SW 194 AVENUE, SW 197 AVENUE, SW 336 STREET AND SW 340 STREET

WITHIN THE PRIVATE ROAD COMMUNITY:

- OPEN SPACE LANDSCAPED AREAS, PRIVATE ROADS

MAINTENANCE SCHEDULE:

A.) LAWN/GRASS

- 1) CUT AS REQUIRED
- 2) FERTILIZE AND WEED CONTROL AS NEEDED
- 3) TREAT FOR PESTS/DISEASES AS NEEDED
- 4) IRRIGATE WITH AUTOMATIC SYSTEM AND ELECTRICAL SERVICE FOR SAME
- 5) MULCHING – PERFORMED TWICE A YEAR OR AS NEEDED

B.) TREES/SHRUBS

- 1) TRIM, FERTILIZE AND TREAT FOR PESTS AS NEEDED
- 2) REPLACE AS REQUIRED

Note: THIS SPECIAL TAXING DISTRICT ENCOMPASSES A PRIVATE DRIVE COMMUNITY AND THE MULTIPURPOSE MAINTENANCE COMPONENT OF THE DISTRICT SHALL BE **DORMANT**. SERVICE WILL ONLY COMMENCE FOLLOWING FAILURE (AS DEFINED IN A “GRANT OF PERPETUAL NON-EXCLUSIVE EASEMENT” SUBMITTED AT THE SAME TIME AS THIS PETITION) OF ANY HOME-OWNER’S ASSOCIATION AND/OR COMMUNITY DEVELOPMENT DISTRICT TO PROVIDE THE REQUIRED SERVICES. ASSUMPTION OF MAINTENANCE SERVICES SHALL COMMENCE FOLLOWING ADOPTION OF THIS DISTRICT’S MULTIPURPOSE MAINTENANCE ASSESSMENT ROLL BY THE BOARD OF COUNTY COMMISSIONERS AT A PUBLIC HEARING. OTHER MAINTENANCE SERVICES MAY BE PROVIDED IN THE FUTURE AS SPECIFIED IN THE DISTRICT’S ORDINANCE AND AMENDMENTS THERETO. IN THE EVENT THIS DISTRICT IS ACTIVATED, THE FOLLOWING AREAS MAY BE MAINTAINED:

- OPEN SPACE LANDSCAPED AREAS, PRIVATE ROADS

(ROAD MAINTENANCE INCLUDES INFRASTRUCTURE REPAIR UPON ACTIVATION OF THE DORMANT MULTIPURPOSE DISTRICT).



MEMORANDUM
(Revised)

TO: Honorable Chairman Anthony Rodriguez
and Members, Board of County Commissioners

DATE: December 16, 2025

FROM: 
Gen Bonzon-Keenan
County Attorney

SUBJECT: Agenda Item No. 5(C)

Please note any items checked.

- “3-Day Rule” for committees applicable if raised**
- 6 weeks required between first reading and public hearing**
- 4 weeks notification to municipal officials required prior to public hearing**
- Decreases revenues or increases expenditures without balancing budget**
- Budget required**
- Statement of fiscal impact required**
- Statement of social equity required**
- Ordinance creating a new board requires detailed County Mayor’s report for public hearing**
- No committee review**
- Applicable legislation requires more than a majority vote (i.e., 2/3’s present ____, 2/3 membership ____, 3/5’s ____, unanimous ____, majority plus one ____, CDMP 7 vote requirement per 2-116.1(3)(h) or (4)(c) ____, CDMP 2/3 vote requirement per 2-116.1(3) (h) or (4)(c) ____, CDMP 9 vote requirement per 2-116.1(4)(c) (2) ____) to approve**
- Current information regarding funding source, index code and available balance, and available capacity (if debt is contemplated) required**

Approved _____ Mayor
Veto _____
Override _____

Agenda Item No. 5(C)
12-16-25

ORDINANCE NO. _____

ORDINANCE CREATING AND ESTABLISHING A SPECIAL TAXING DISTRICT IN MIAMI-DADE COUNTY, FLORIDA, GENERALLY BOUNDED ON THE NORTH BY SW 336 STREET, ON THE EAST BY SW 194 AVENUE, ON THE SOUTH BY SW 340 STREET, AND ON THE WEST BY SW 197 AVENUE (RICHARD ROAD), KNOWN AND DESCRIBED AS ACACIA GROVES MULTIPURPOSE MAINTENANCE AND STREET LIGHTING SPECIAL TAXING DISTRICT; IDENTIFYING SERVICES TO BE PROVIDED; AUTHORIZING AND DIRECTING THE COUNTY MAYOR OR COUNTY MAYOR'S DESIGNEE TO CAUSE TO BE MAINTAINED AND OPERATED VARIOUS PUBLIC IMPROVEMENTS AND TO PROVIDE FOR THE INSTALLATION OF STREETLIGHTS; APPROVING A STREET LIGHTING AGREEMENT WITH FLORIDA POWER AND LIGHT AND AUTHORIZING THE COUNTY MAYOR OR COUNTY MAYOR'S DESIGNEE TO EXECUTE THE AGREEMENT; WAIVING PROVISIONS OF RESOLUTION NO. R-130-06; AND PROVIDING FOR EXCLUSION FROM THE CODE AND AN EFFECTIVE DATE

WHEREAS, this Board desires to accomplish the purposes outlined in the accompanying memorandum, which is incorporated herein by reference, and

WHEREAS, a public hearing has been conducted by the Board of County Commissioners in accordance with the requirements and procedures of chapter 18 of the Code of Miami-Dade County,

BE IT ORDAINED BY THE BOARD OF COUNTY COMMISSIONERS OF MIAMI-DADE COUNTY, FLORIDA:

Section 1. This Board incorporates and approves the foregoing recitals as if fully set forth herein.

Section 2. In accordance with the provisions of chapter 18 of the Code, a special taxing district to be known and designated as the Acacia Groves Multipurpose Maintenance and Street Lighting Special Taxing District in Miami-Dade County, Florida, is hereby created and established in the unincorporated area of Miami-Dade County.

Section 3. The area or boundaries of this Special Taxing District, generally bounded on the north by SW 336 Street, on the east by SW 194 Avenue, on the south by SW 340 Street, and on the west by SW 197 Avenue, and located entirely within Commission District 9, are as follows:

A portion of Section 23, Township 57 South, Range 38 East, Miami-Dade County, Florida (a.k.a. Acacia Groves, Tentative Plat # T-25070); being more particularly described as follows:

The Northwest 1/4 of the Southwest 1/4 of said Section 23, less the North 35.00 feet and the West 35.00 feet of said Tract; said land lying and being in Miami-Dade County, Florida.

Also known as:

Commence at the Northwest corner of the Northwest 1/4 of the Southwest 1/4 of Section 23, Township 57 South, Range 38 East, Miami-Dade County, Florida; also being the West 1/4 corner of said Section 23, thence run along the North line of the Southwest 1/4 of said Section 23, North 89°18'22" East for a distance of 1,333.19 feet to the Northeast corner of the Northwest 1/4 of the Southwest 1/4 of said Section 23; the next two described courses being along the East line of the Northwest 1/4 of the Southwest 1/4 of said Section 23; thence South 00°23'22" East for 35.00 feet to the Point of Beginning of the following described parcel; thence continue South 00°23'22" East for 1,298.92 feet to the Southeast corner of the Northwest 1/4 of the Southwest 1/4 of said Section 23; thence run along the South line of the Northwest 1/4 of the Southwest 1/4 of said Section 23, South 89°30'47" West for a distance of 1,293.65 feet; thence run along a line parallel with and 35.00 feet easterly of, as measured at right angles to, the West line of the Southwest 1/4 of said Section 23, North 00°35'04" West for a distance of 1,294.24 feet to a point; thence run along a line parallel with and 35.00 feet southerly of, as measured at right angles to, the North line of the Southwest 1/4 of said Section 23, North 89°18'22" East for

a distance of 1,298.07 feet to the Point of Beginning, containing 1,680,179 square feet more or less, or 38.572 acres more or less.

The areas and geographical locations of this Special Taxing District are shown on the map or sketch, attached to the accompanying memorandum.

Section 4. The improvements and/or services to be provided in this Special Taxing District will consist of the following:

- A) Maintenance of landscaped swales, medians, common areas, any entrance features, wetlands, lakes, and the exterior faces of any fencing or walls within the Special Taxing District's boundaries abutting public rights-of-way, including maintenance of turf, trees, shrubs, irrigation, and utility payments should any association or community development district fail to provide these services. The Special Taxing District will also maintain the private road areas if there is a failure to provide maintenance within the private road areas as defined in a non-exclusive easement granted to Miami-Dade County and recorded in the Public Records.
- B) Street lighting services within public rights-of-way, as described in the Report.

Section 5. A) Multipurpose Maintenance – Initially, services will be provided by petitioner. The current estimate of combined costs of the multipurpose maintenance services and operations by the Special Taxing District, if activated, including engineering, administration, billing, collecting and processing, is \$313,905.83 (\$0.2880 per assessable square foot). The assessments will be adjusted based on actual costs.

B) Street Lighting Services – The installation of such street lighting will be accomplished pursuant to an agreement between Miami-Dade County and Florida Power and Light. The expected costs of the installation and operation of the Special Taxing District's services, including maintenance, electricity, engineering, administration, billing, collecting and processing, for the first year are provided by petitioners and estimated to be \$49,396.35. The expected costs of the Special Taxing District's services for the second year are estimated to be

\$9,559.17. The expected estimated cost per assessable front foot of real property within the Special Taxing District for the second year is \$1.9788. The succeeding years' assessments will be adjusted based on actual costs.

Section 6. The entire cost of the Special Taxing District's improvements and/or services shall be specially assessed. It is hereby declared that said improvements and/or services will be a special benefit to all properties within the Special Taxing District and the total amount of special assessments to be levied as aforesaid will not be in excess of such special benefit.

Section 7. A) Multipurpose Maintenance - If the multipurpose maintenance services are activated, Miami-Dade County, as administrator of this Special Taxing District's maintenance programs, is directed to provide service by the most effective and efficient means available on a yearly basis, as detailed in the Report, which is made a part hereof by reference. If there is a proposed significant change to the level of service to be provided, the Parks, Recreation and Open Spaces Department shall conduct a meeting in the community, inviting all affected Special Taxing District property owners for the purpose of reviewing the Special Taxing District's budget and level of service.

B) Street Lighting Services - The proposed street lighting agreement between Miami-Dade County and Florida Power and Light is hereby approved and made a part hereof by reference. The provisions of Resolution No. R-130-06 are hereby waived because adoption of this Ordinance is a precursor to the future execution of said agreement, which will not occur until development within the Special Taxing District occurs.

Section 8. A) Multipurpose Maintenance - If the multipurpose maintenance services are activated, the County Mayor or County Mayor's designee is authorized and directed to cause to be made the maintenance and operation of various public improvements to be installed within the Special Taxing District in accordance with the provisions of this Ordinance.

B) Street Lighting Services - The County Mayor or County Mayor's designee is hereby authorized and directed to execute at the appropriate time the incorporated street lighting agreement, in substantially the form attached to the accompanying memorandum, for and on behalf of Miami-Dade County.

Section 9. The County Mayor or County Mayor's designee is authorized and directed to cause the installation of said streetlights to be accomplished within the Special Taxing District in accordance with the provisions of said agreement and the terms of this Ordinance.

Section 10. The County Mayor or County Mayor's designee is further directed to cause to be prepared and filed with the Clerk one Preliminary Assessment Roll for the street lighting services in accordance with the provisions of sections 18-14 and 18-22.1 of the Code. In the event that the multipurpose maintenance services are activated, the County Mayor or County Mayor's designee is further directed to cause to be prepared and filed with the Clerk one Preliminary Assessment Roll for those services in accordance with the provisions of section 18-14 of the Code. As authorized by section 197.3632, Florida Statutes, all special assessments levied and imposed under the provisions of this Ordinance shall be collected, subject to the provisions of chapter 197, Florida Statutes, in the same manner and at the same time as ad valorem taxes. Unless paid when due, such special assessments shall be deemed delinquent and payment thereof may be enforced by means of the procedures provided by the provisions of chapter 197, Florida Statutes, and section 18-14 of the Code, including possible loss of title.

Section 11. A duly certified copy of this Ordinance shall be filed in the Office of the Clerk of the Circuit Court of Miami-Dade County, Florida, and recorded in the appropriate book of records.

Section 12. It is the intention of the Board, and it is hereby ordained that the provisions of this Ordinance shall be excluded from the Code.

Section 13. The provisions of this Ordinance shall become effective 10 days after the date of its enactment, unless vetoed by the Mayor, and if vetoed, shall become effective only upon an override by this Board.

PASSED AND ADOPTED:

Approved by County Attorney as
to form and legal sufficiency:



Prepared by:



Ryan Carlin