



STANDARD WOOD FENCE

Section 2328 FBC
 6'-0" MAXIMUM HEIGHT

Address: _____

Fence Height: _____ FT Fence Length: _____ FT

**** IMPORTANT FOR USE OF POOL BARRIER ****

Outdoor swimming pools shall be provided with a barrier complying with Florida Building Code Sections 424.2.17.1.1 through 424.2.17.1.14.

Access gates shall be equipped with a self-closing self-latching locking device located no less than 54 inches from the bottom of the gate. The device release mechanism shall be located on the pool side of the gate and so placed that it cannot be reached by a young child over the top or through any opening or gap. Gates that provide access to the swimming pool must open outward away from the pool.

The top of the barrier shall be at least 48 inches above grade measured on the side of the barrier which faces away from the swimming pool.

The maximum vertical clearance between grade and the bottom of the barrier shall be 2 inches measured on the side of the barrier which faces away from the swimming pool.

The spacing between the vertical members shall not exceed 1 3/4 inches in width. FBC R. sect. 4501.17.1.4.

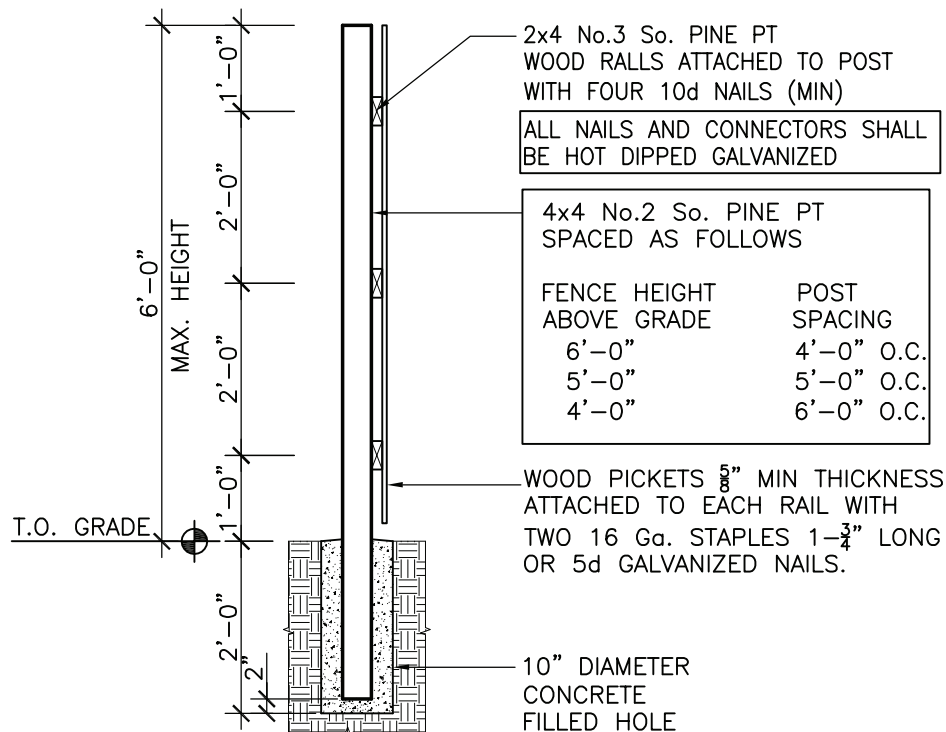

NOTES:

1. FINISH SIDE OF ALL WOOD FENCES MUST FACE OUTWARD TOWARD NEIGHBORING PROPERTY OR STREET PER ZONING CODE 33-11.
2. IN POOL BARRIERS, THE SPACING BETWEEN THE VERTICAL MEMBERS SHALL NOT EXCEED 1 3/4 INCHES IN WIDTH. FBC R. SECT. 4501.17.1.4.