

# Memorandum



**Date:** July 5, 2017

**To:** Laurie Johnson, SBD Section Chief  
Internal Services Department, Small Business Development

**From:** *for the* *Jackie Focke*  
Milton L. Collins, Associate Director  
Miami-Dade Aviation Department, Minority Affairs Division

**Subject:** MIA - Central Terminal Ticket Counters G-H Area - Fish Finders  
Project No. MCC V043A-2

---

## **RECOMMENDATION:**

This memorandum is to inform Small Business Development (SBD) that MCM was directed to proceed with the Fabrication and Procurement of forty-four (44) FISH Finders for the MIA Central Terminal Area Ticket Counters G-H Area, Project No. MCC V043A-2.

No Contract Measures can be achieved due to the nature of this project being Fabrication-Only and not Trade Specific.

Attached is a copy of Project Order #65, and the Project Order Proposal documents. Please advise our office if there are questions.

### Attachments

c: A. Calderin, MCM  
V. Mirabal, MCM  
I. McNeil, MCM  
C. Corrales, MDAD  
File

### Project Order #65

PROJECT NAME: MIA Central Terminal Ticket Counters G-H Area PROJECT NO: V043A-2  
 CONTRACT TITLE: Miscellaneous Construction Contracts, MCC-8-10 DATE: 06/29/2017  
 CONTRACTOR: MCM Corporation PAGES: 1

**SCOPE:** Manufacturing of 44 fish finders, 22 right sides and 22 left sides.

**FUNDING SOURCE:** V043A MIA Central Terminal E-H Ticket Counters.

**PLANS AND SPECIFICATIONS:** Jervis' Webb Shop Drawings dated June 10, 2005 & Overall Floor Plan (Exhibit 1) – Dated June 22, 2017.

**CSBE CONTRACT MEASURES:** Emergency Basis – Not Contract Measures due to Emergency

**TIME OF COMPLETION:** Target date to complete the procurement is August 31, 2017.

**LIQUIDATED DAMAGES:** Three hundred (\$300) per calendar day.

IN CONSIDERATION FOR PERFORMANCE IN ACCORDANCE WITH TERMS AND CONDITIONS OF THIS PROJECT ORDER, THE COUNTY HEREBY AGREES TO PAY THE CONTRACTOR NOT EXCEED THE SUM OF: \$ 81,172.96 (Eighty One Thousand One Hundred Seventy Two Dollars and Ninety Six Cents) WHICH INCLUDES THE 8.52% MARKUP, UNLESS THIS SUM IS INCREASED/DECREASED BY A PROJECT ORDER MODIFICATION. IN WITNESS WHEREOF, THE PARTIES HERETO HAVE CAUSED THIS PROJECT ORDER TO BE EXECUTED BY THEIR APPROPRIATE OFFICIALS AS OF THE DATE FIRST ABOVE WRITTEN.

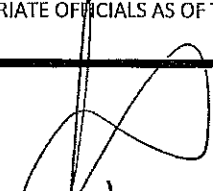
<p>By: <u></u> <u>6/30/17</u>          ACCEPTED: GENERAL CONTRACTOR DATE          PRINT NAME: Alberto Calderin</p>	<p>By: _____          APPROVED: PROJECT CONSULTANT DATE          PRINT NAME: Cristina Fandino (Cristina Fandino Architects Inc.)</p>
<p>By: _____          APPROVED: MDAD PROGRAM MANAGER DATE          PRINT NAME: Sergio Negrelra</p>	<p>By: _____          RECOMMENDED: MGR. MINORITY AFF. DATE          PRINT NAME: Milton Collins</p>
<p>By: _____          RECOMMENDED: CONSULTING ENGINEER (HNTB) DATE          PRINT NAME: Jose M. Diaz</p>	<p>By: _____          RECOMMENDED: MDAD CHIEF FINANCIAL OFFICER DATE          PRINT NAME: Sandra Bridgeman</p>
<p>By: _____          RECOMMENDED: MDAD SECTION CHIEF DATE          PRINT NAME: Enrique Perez</p>	<p>By: _____          APPROVED: ASST. AVIATION DIR OF FACILITIES DEPT. DATE          PRINT NAME: Pedro Hernandez</p>

cc: A/E, MDAD-Project Control, NTD Project Control, MDAD-Minority Affairs, MCM Corp., HNTB, MDAD Project Manager, Project File.

MUNILLA CONSTRUCTION MANAGEMENT, LLC (MCM)  
 PROJECT ORDER PROPOSAL

MDAD-MCC-8-10

Project Name: MIA-Central Terminal Ticket Counters G-H Area

Project Number: MCC-V043A-2

**Table of Contents**

	Page No.
Project Order	Cover Page
MCM's Project Order Proposal	1
MCM's Project Order Proposal Summary	2
MCM's Bid Tabulation Sheet	3
Memorandum to MDAD - No Contract Measures Notice	4
MDAD E-Mail - Authorization to Proceed	5
MCM's Request for Proposal to Bidders	6
MDAD Pre-Construction Project Order Draft #65	7 -18
MDAD Directive to Procure Proposals	19 - 22
MCM's Bid Submittal/Attendance Sign In Sheet	23 - 24
<b>Successful Bidder(s)</b>	25
Paradise Awnings Corp.	26
<b>Un-Successful Bidder(s)</b>	27
Doubney Sheet Metal Works	28
Fleites Construction Group, Inc.	29



June 28, 2017

Mr. Sergio Negreira  
Project Manager  
Miami Dade Aviation Department  
P.O. Box 025504  
Miami, Florida 33102-5504

RE: MIA- Central Terminal Ticket Counters G-H Area -- Fish Finders  
MCC- V043A-2

Dear Mr. Negreira:

We are pleased to present to you the following **Project Order Proposal** for the above referenced project.

**Project Estimate: \$81,172.96** (Eighty One Thousand One Hundred Seventy Two Dollars and Ninety Six Cents).

Liquidated Damages and Liquidated Indirect: N/A

This project is to be completed in approximately calendar days.

This proposal is broken down on the attached spreadsheet, and is based on the following conditions.

Jevis Webb Shop Drawings dated June 10, 2007 (95 H-F-EIS)  
and Overall Floor Plan Dated June 22, 2017

1. Work to begin, after approved Project Order and after receipt of approved Building Permits and Notice to Proceed.
2. This estimate includes an allowance account for unforeseen conditions.
2. This estimate will stay in effect for a period of not more than thirty (30) days from the date of this correspondence.

If there are any questions, please do not hesitate to contact me.

Sincerely,

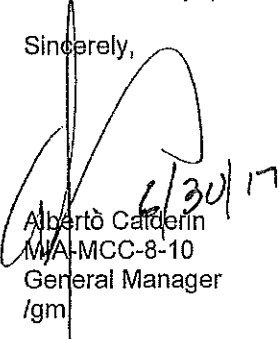
  
Alberto Calderin  
MIA-MCC-8-10  
General Manager  
/gm

Cc: Milton Collins – MDAD Minority Affairs Division

1829



Date: June 28, 2017

To: Mr. Milton L. Collins, Associate Director, MDAD Min. Affairs

From: Alberto Calderin, Munilla Construction Management, (MCM)

Subject: Project Order Proposal Summary  
MIA - Central Terminal Ticket Counters G-H Area - FISH FINDERS, MCC V043A-2

*[Handwritten signature]*  
6/30/17

The following is our Project Order Proposal Summary of low bidders:

<u>Package</u>	<u>Subcontractor</u>	<u>Package Description</u>	<u>SBE/Const</u> <u>Goal</u>	<u>\$ Amount</u>
-	Paradise Awnings Corporation	Fabrication of Fish Finders	N/A	\$74,800.00
			Subtotal	<u>\$74,800.00</u>
		MCC Fee (8.52%)		\$6,372.96
			Subtotal	<u>\$81,172.96</u>
		<b>TOTAL</b>		<b>\$81,172.96</b>

No contract measures can be assigned as this is a procurement/fabrication scope only, not trade specific.

cc: Mr. Sergio Negreira - Project Manager  
Rebecca Figueroa  
File

*2829*



Ginny Mirabal

---

From: Perez, Enrique (Aviation) [EPEREZ@miami-airport.com]  
Sent: Thursday, June 29, 2017 11:18 AM  
To: Ginny Mirabal; Figueroa, Rebecca (NTD)  
Cc: Alberto Calderin; Gomez, Adriana M. [TOP]; Barrenechea, Maria [TOP]  
Subject: MCC-8-10 - Ticket Counter Scale "Fish Finders" - Authorization  
Attachments: FISH FINDERS BIDS AND BID TAB SHEET.pdf

Please proceed with the fabrication of the ticket counter weight displays ("fish finders"). A SAO/PO is forthcoming.

Thanks.

---

From: Figueroa, Rebecca (NTD)  
Sent: Wednesday, June 28, 2017 3:16 PM  
To: Negreira, Sergio (Aviation)  
Cc: Barrenechea, Maria [TOP]; [vmirabal@mcm-us.com](mailto:vmirabal@mcm-us.com)  
Subject: FW: MCC-8-10 - Ticket Counter Scale "Fish Finders" - BID RESULTS

Sergio,

I was present during the bid opening and right after we called the lowest bidder to discuss delivery of the fish finders by July 12, 2017.  
I approved the go ahead for Paradise Awning to commence fabrication of Fish Finders.

Please send notification to MCM on Notice to proceed.

Thank you,

Rebecca Figueroa  
Project Manager

---

From: Ginny Mirabal [[vmirabal@mcm-us.com](mailto:vmirabal@mcm-us.com)]  
Sent: Wednesday, June 28, 2017 2:18 PM  
To: '[ralayon@paradiseawnings.com](mailto:ralayon@paradiseawnings.com)'; '[malcibar@paradiseawnings.com](mailto:malcibar@paradiseawnings.com)'; '[humberto@fleitesconstructiongroup.com](mailto:humberto@fleitesconstructiongroup.com)'; '[humberto@fleitesconstructiongroup.com](mailto:humberto@fleitesconstructiongroup.com)'; '[richardp@doudney.com](mailto:richardp@doudney.com)'  
Cc: Alberto Calderin; Johnny Peterson; Figueroa, Rebecca (NTD); Bao-Garciga, Aida (Aviation); Ionnie McNeill; Leticia Green; Jose E. Morales; Miguel A. Perez  
Subject: RE: MCC-8-10 - Ticket Counter Scale "Fish Finders" - BID RESULTS

## Ginny Mirabal

---

**From:** Ginny Mirabal  
**Sent:** Friday, June 23, 2017 8:49 AM  
**To:** ralayon@paradiseawnings.com; malcibar@paradiseawnings.com; humberto Fleites; 'humberto@fleitesconstructiongroup.com'; 'richardp@doudney.com'  
**Cc:** Alberto Calderin; Johnny Peterson; 'Figueroa, Rebecca (NTD)'; Bao-Garciga, Aida (Aviation); tonnie McNeill; Leticia Green; Jose E. Morales; Miguel A. Perez  
**Subject:** MCC-8-10 - Request for Proposal: Ticket Counter Scale "Fish Finders"  
**Attachments:** 5271\_fishfinder dwgs.pdf

Good Morning,

MCM is requesting a proposal per the attached drawings for fabricating 44 fish finders. The immediate need is for 18 fish finders to be manufactured and delivered on site by July 12, 2017. The remainder of the other 26 fish finders to be delivered by August 16, 2017.

These proposal are to be submitted to MCM's Airport office in a sealed envelope by June 28, 2017 @ 2:00PM.

Address is:

4301 N.W. 22nd Street, Building 3030, 2nd Floor, Miami, FL 33122 (West Wing)

Ginny Mirabal

PH: 305-541-0000 Ext 230

DL: 305-869-4563

M: 305-301-9458

[www.mcm-us.com](http://www.mcm-us.com)

please provide a quote to developed new "fish finder" units per attached drawings for reference, and installation for future consideration.

Also include time estimate to develop units.

Thank you,

-----

This email has been scanned for spam and viruses by Proofpoint Essentials. Visit the following link to report this email as spam:

<https://us1.proofpointessentials.com/index01.php?mod id=11&mod option=logitem&mail id=1498067022-sjibjIN55VzS&r address=vmirabal%40mcm-us.com&report=>



MCM, LLC  
JUN 23 2017  
MCC-8-10

**Pre-Construction Project Order Draft #65**

PROJECT NAME: MIA Central Terminal Ticket Counters G-H Area

PROJECT NO: V043A-2

CONTRACT TITLE: Miscellaneous Construction Contracts, MCC-8-10

DATE: 06/22/2017

CONTRACTOR: MCM Corporation

PAGES: 1

PLEASE SUBMIT WITHIN 2 CALENDAR DAYS FROM THE DATE OF THIS PRE-CONSTRUCTION PROJECT ORDER DRAFT THE PROJECT CONSTRUCTION PACKAGING PLAN FOR THE SUBJECT PROJECT IN ACCORDANCE WITH THE CONTRACT AND THE CONDITIONS OF THIS PRE-CONSTRUCTION PROJECT ORDER DRAFT.

**SCOPE:** Procurement of 44 fish finders, 22 right side and 22 left side.

**PLANS AND SPECIFICATIONS:** Jervis' Webb Shop Drawings dated June 10, 2005 enclosed (95 H-F-EIS) & Overall Floor Plan (Exhibit 1) -- Dated June 22, 2017.

**CSBE CONTRACT MEASURES:** Emergency Basis -- SBE/Construction Trade Set-aside

**TIME OF COMPLETION:** Target date to complete the procurement is August 31, 2017.

**JUSTIFICATION:** In order to complete the new ticket counters for the above mentioned project, new fish finders need to be procured and installed for the scale readers to work. Fish Finders were not allowed to be part in the original contract with JBT. Now we are in an emergency to procure, and install on site by July 18th, 2017, which is the scheduled opening date for Phase 1 and 2 of the ticket counters. The project needs a total of (44) fish finders, but only (18) of them (Phase 1 and 2) are required by the 14th of July, (9) left and (9) right. It is very important to get pricing and delivery date from potential bidders.

By: <u>[Signature]</u> <u>6/23/17</u> APPROVED: PROJECT CONSULTANT PRINT NAME: Cristina Fandino (Cristina Fandino Architects Inc. )	By: <u>[Signature]</u> <u>6/23/17</u> RECOMMENDED: MGR. MINORITY AFF. PRINT NAME: Milton Collins
By: <u>[Signature]</u> <u>6/23/17</u> RECOMMENDED: MDAD PROGRAM MANAGER PRINT NAME: Sergio Negreira	By: _____ N/A _____ RECOMMENDED: HNTB PRINT NAME: Jose Diaz
By: <u>[Signature]</u> <u>6/23/17</u> RECOMMENDED: MDAD SECTION CHIEF PRINT NAME: Aldo Bao-Garcia	By: <u>[Signature]</u> <u>6/23/17</u> APPROVED: ASST. AVIATION DIR OF FACILITIES DEPT. PRINT NAME: Pedro Hernandez

cc: A/E, MDAD-Project Control, NTD Project Control, MDAD-Minority Affairs, MCM Corp., HNTB, MDAD Project Manager, Project File.

7 8 29

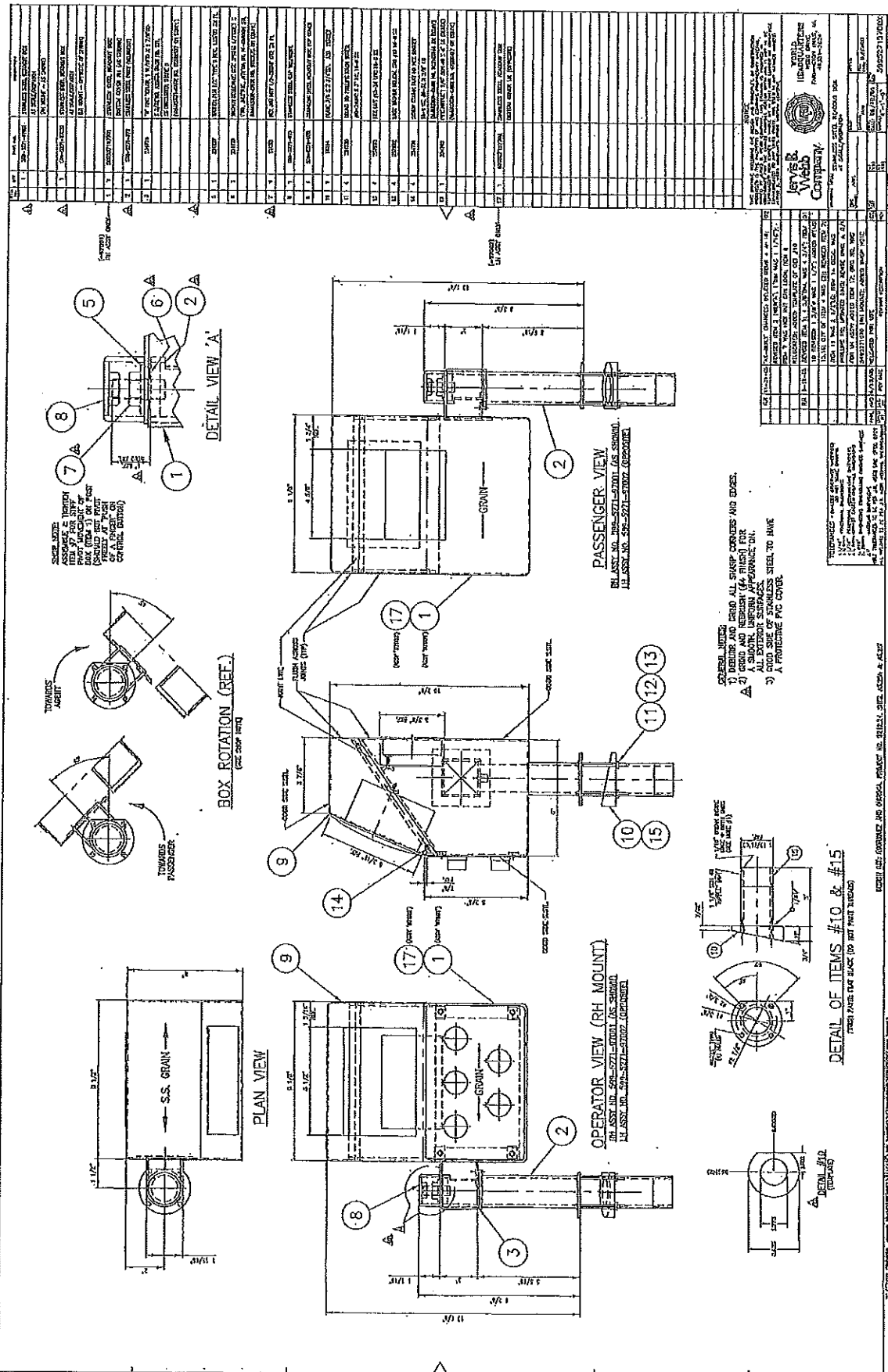

NOTICE: THIS DRAWING INCLUDING THE DESIGN AND PRINCIPLES OF CONSTRUCTION DISCLOSED IS THE PROPERTY OF THE JERVIS B. WEBB COMPANY AND IS SUBMITTED WITH THE UNDERSTANDING THAT IT IS NOT TO BE REPRODUCED, NOR COPIED IN WHOLE OR IN PART, NOR LOANED OR OTHERWISE COMMUNICATED TO ANY THIRD PARTY, NOR USED IN ANY MANNER DETRIMENTAL TO THE JERVIS B. WEBB COMPANY WITHOUT ITS EXPRESS CONSENT.

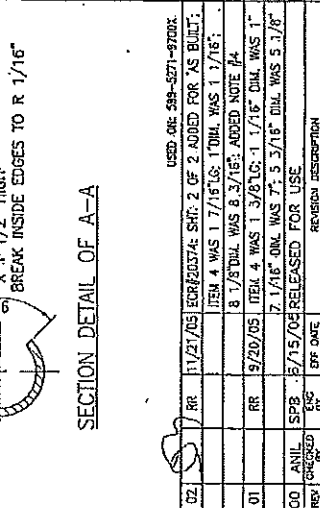
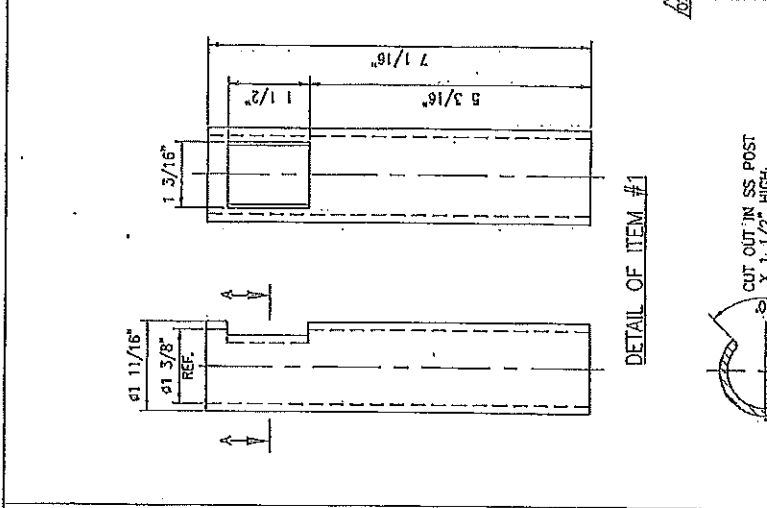
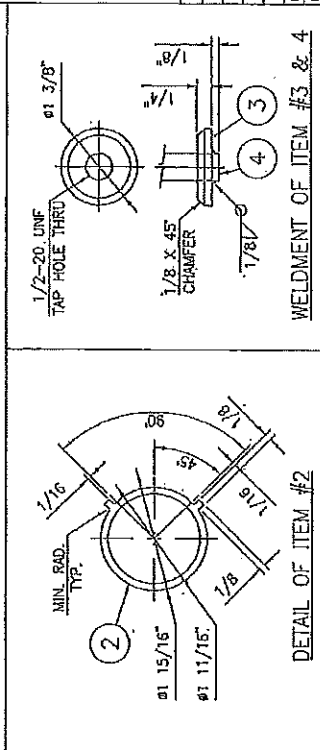
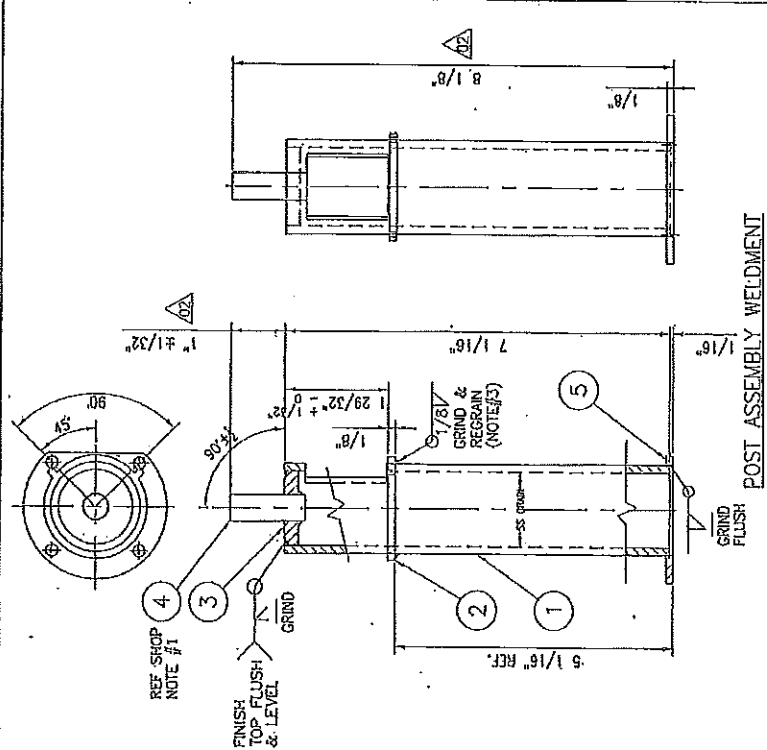

ITEM NO.	QTY	PART NO.	DESCRIPTION
1	1	589-5271-973	STAINLESS STEEL POST (WELDMENT)
2	1	234723	PIPE SEAMLESS SCH 40 30SS 1-1/4" O.D. DIA (LEG. COIL L&T) X 7 1/16" LG.
3	1	229662	SHI TUBA JUMPS X 2 X 2 PERDET
4	1	18204	P. 1/2" X 1/2" X 1 3/8" DIA PERDET
5	1	234724	DR RD TUB 1/2-20UNF X 1 3/8" LG.
6	1	229662	316 STL GR (8000)
7	1	229662	SHI TUBA JUMPS X 2 1/2" DIA PERDET

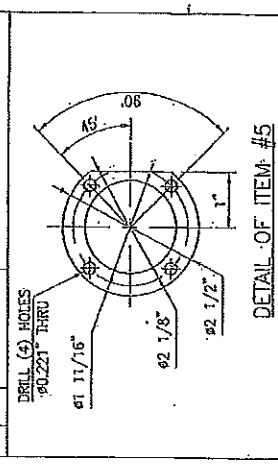

SHOP NOTE:  
 1. WELD ITEM #4 TO ITEM #3 BEFORE WELDING TO ITEM #1.  
 2. BREAK SHARP CORNERS GRIND AND REGRIND.  
 3. SHOP FINISH OUTSIDE OF POST ASS. TO A #4 BRUSH FINISH.  
 4. SEE SH. 2 FOR TEMPLATE OF ITEMS 2, 3, & 5.

TOLERANCES: (UNLESS OTHERWISE SPECIFIED)  
 ±1/16" FRACTIONAL DIMENSIONS  
 ±1.5mm FRACTIONAL ACCUMULATIVE DIMENSIONS  
 ±1.5mm CANNOT EXCEED OVER-ALL DIMENSIONS  
 ±.010" DIMENSIONS CONTROLLING FINISHED SURFACES  
 ±.010" ANGULAR DIMENSIONS  
 ALL WELDING TO BE PER J.B. WEBB WELDING SPECIFICATIONS

**Jervis B. Webb Company**  
 WORLD HEADQUARTERS  
 WEBB DRIVE  
 FARMINGTON HILLS, MI  
 48331-5624

DRAWING TITLE: STAINLESS STEEL POST (WELDMENT)  
 (SHEET 1 OF 2)

DES: P. RINGHOJZ  
 APPR: D. BEARD  
 DATE: 05/11/05  
 SCALE: 6"=12"

REV	DATE	BY	DESCRIPTION
02	11/21/05	RR	11/21/05 ECR/EST/TA: SH. 2 OF 2 ADDED FOR AS BUILT.
01	8/20/05	RR	ITEM 4 WAS 1 7/16" LG. T.DIM. WAS 1 7/16". 8 1/8" DIL WAS 8 3/16". ADDED NOTE #4.
00	8/15/04	SPB	ITEM 4 WAS 1 3/8" LG. 1 1/16" DIL. WAS 1 1/16". 7 1/16" DIL. WAS 7 1/16". DIL. WAS 5 3/8". 7 1/16" DIL. WAS 7 1/16". DIL. WAS 5 3/8".

11/29/05 11:35:28 drringh \\PROJECT\CONTRACT\65271\unithnd\details\SS redbout\_box\589527197JCR2.dwg

6286





NOTICE: THIS DRAWING INCLUDING THE DESIGN AND PRINCIPLES OF CONSTRUCTION DISCLOSED IS THE PROPERTY OF THE JERVIS B. WEBB COMPANY AND IS SUBMITTED WITH THE UNDERSTANDING THAT IT IS NOT TO BE REPRODUCED, NOR COPIED IN WHOLE OR IN PART, NOR LOANED OR OTHERWISE COMMUNICATED TO ANY THIRD PARTY, NOR USED IN ANY MANNER DETRIMENTAL TO THE JERVIS B. WEBB COMPANY WITHOUT ITS EXPRESS CONSENT.

ITEM NO.	QTY	PART NO.	DESCRIPTION
1	1	5995271975	STAINLESS STEEL CAP WELDMENT.
1	1	234723	PIPE STAINLESS SCH 40 JAWSS 1-7/16" O.D. (1.65" O.D. 1.35" I.D.) X 1-1/16" LG.
2	1	229652	SMT. TORX BOLTS X 1-3/8" DIA.
3	1	58566	WAS. WAS. NUT 1/2"-20X1.688

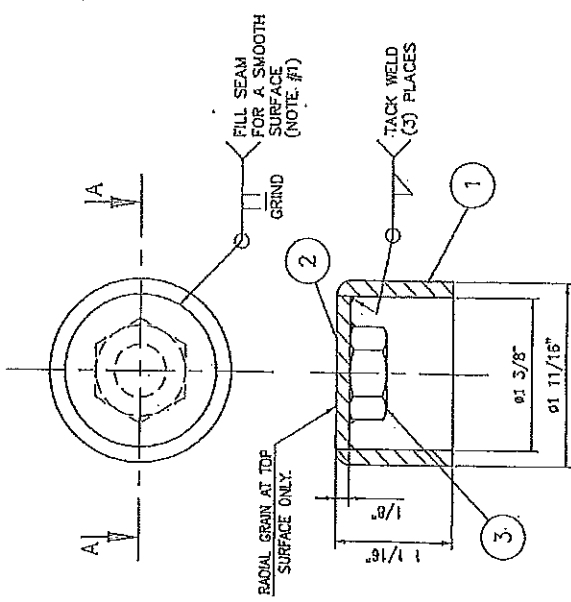

SECTION - AA

SHOP NOTE:  
1. GRIND & REGRIND TO MATCH PARENT ASSY. (#4 BRUSH FINISH)

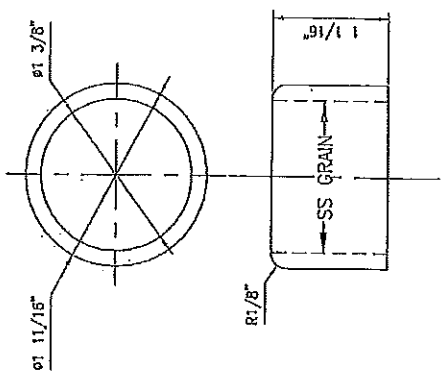

DETAIL OF ITEM #1

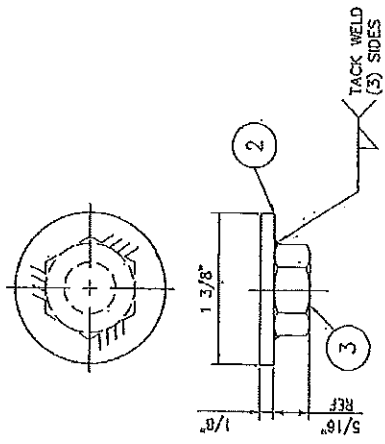

WELDMENT OF ITEM #2 & 3

TOLERANCES: (UNLESS OTHERWISE SPECIFIED)  
 ±1/16" FRACTIONAL DIMENSIONS  
 ±1.6mm FRACTIONAL ACCUMULATIVE DIMENSIONS  
 ±1/16" CANNOT EXCEED OVER-ALL DIMENSIONS  
 ±.010" DIMENSIONS CONTROLLING FINISHED SURFACES  
 ±.25mm ANGULAR DIMENSIONS  
 ALL WELDING TO BE PER J.B. WEBB WELDING SPECIFICATIONS



Jervis B. Webb Company  
 WORLD HEADQUARTERS  
 WEBB DRIVE  
 FARMINGTON, CT 06031-5824

USED ON: 599-5271-9700X

REV	BY	CHKD	DATE	REVISION DESCRIPTION
01	RR	RR	9/20/05	FABRICATION RELEASE
00	ANIL	SPB	6/15/05	RELEASED FOR USE
REV	REVISION	DATE	BY	DESCRIPTION

SCALE: 1:1

DRAWING TITLE: STAINLESS STEEL CAP WELDMENT.

DESIGNER: R. RINGHOLZ  
 DRAWN: SPB  
 DATE: 06/11/05  
 NO. 599-5271-975

05/20/05 14:54:56 drringh I:\PROJECT\CONTRACT\95271\unifhand\details\Stainless\5995271975R1.dwg

Handwritten signature or initials.

NOTICE: THIS DRAWING INCLUDING THE DESIGN AND PRINCIPLES OF CONSTRUCTION DISCLOSED IS THE PROPERTY OF THE JERVIS B. WEBB COMPANY AND IS SUBMITTED WITH THE UNDERSTANDING THAT IT IS NOT TO BE REPRODUCED, NOR COPIED IN WHOLE OR IN PART, NOR LOANED OR OTHERWISE COMMUNICATED TO ANY THIRD PARTY, NOR USED IN ANY MANNER DETRIMENTAL TO THE JERVIS B. WEBB COMPANY WITHOUT ITS EXPRESS CONSENT.

ITEM NO.	QTY	PART NO.	DESCRIPTION
1	1	599-5271-976	STAINLESS STEEL READOUT BOX TOP COVER
1	1	234722	SHT. 16GA. 304SS #4 BRUSH FINISH W/PROTECTIVE COVER 7 3/8" X 19 1/4" LG PERDET
2	1	234722	SHT. 16GA. 304SS #4 BRUSH FINISH W/PROTECTIVE COVER 6" X 8" LG PERDET

- NOTES:
- 1) ALL BENDS MIN. RAO. UNLESS NOTED.
  - 2) BREAK SHARP CORNERS (TYP).
  - 3) GRIND AND REBRUSH FINISH FOR A SMOOTH AND UNIFORM APPEARANCE ALONG SEAMS AND CORNERS.
  - 4) ALL WELDS TO BE REGRAINED TO MATCH THE UNAFFECTED GRAIN AREA.
  - 5) GOOD SIDE OF STAINLESS STEEL MUST HAVE A PROTECTIVE PVC COVER.

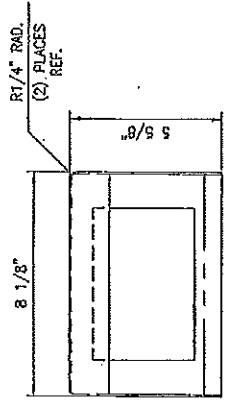
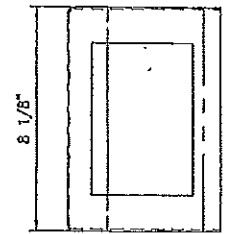
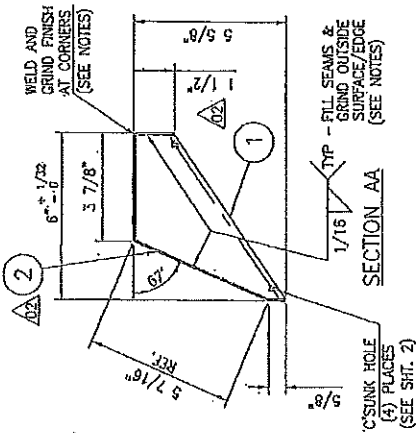
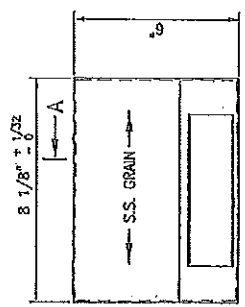

TOLERANCES: (UNLESS OTHERWISE SPECIFIED)  
 ±1/16" FRACTIONAL DIMENSIONS  
 ±1.6mm FRACTIONAL ACCUMULATIVE DIMENSIONS  
 ±1/16" CANNOT EXCEED OVER-ALL DIMENSIONS  
 ±.010 DIMENSIONS CONTROLLING FINISHED SURFACES  
 ±.25mm ANGULAR DIMENSIONS  
 ALL WELDING TO BE PER J.B. WEBB WELDING SPECIFICATIONS



Jervis B. Webb Company  
 WORLD HEADQUARTERS  
 WEBB DRIVE  
 FARMINGTON HILLS, MI  
 48331-5654

USED ON 599-5271-97604

RR	11/22/05	ECR120374	AS BUILT: SHT. 2 REVISED & ADDED SHT. 3, B/4 REVISED (ADDED ITEM 2): 1 1/2 DIM. W/S 1 7/16"
RR	9/18/05	SHT. 2 REVISED-UPDATED NOTES	
RR	AND	B/13/05	RELEASED FOR USE
REV	DATE	BY	REASON DESCRIPTION

DATE	APP'D	CHK'D	DRW'G	SCALE
			1/8" = 1"	

11/29/05 11:02:20 dir\proj\PROJECT\CONTRACT\B5271\unit\hnd\detail\SS readout box 5995271976R2.dwg

13 of 29

NOTICE: THIS DRAWING INCLUDING THE DESIGN AND PRINCIPLES OF CONSTRUCTION DISCLOSED IS THE PROPERTY OF THE JERVIS B. WEBB COMPANY AND IS SUBMITTED WITH THE UNDERSTANDING THAT IT IS NOT TO BE REPRODUCED, NOR COPIED IN WHOLE OR IN PART, NOR LOANED OR OTHERWISE COMMUNICATED TO ANY THIRD PARTY, NOR USED IN ANY MANNER DETRIMENTAL TO THE JERVIS B. WEBB COMPANY WITHOUT ITS EXPRESS CONSENT.

REV. NO.	DATE	DESCRIPTION
1	5/99-5271-976	STAINLESS STEEL READOUT BOX TOP COVER
		SEE SHIT 1 OF 3 FOR BOX

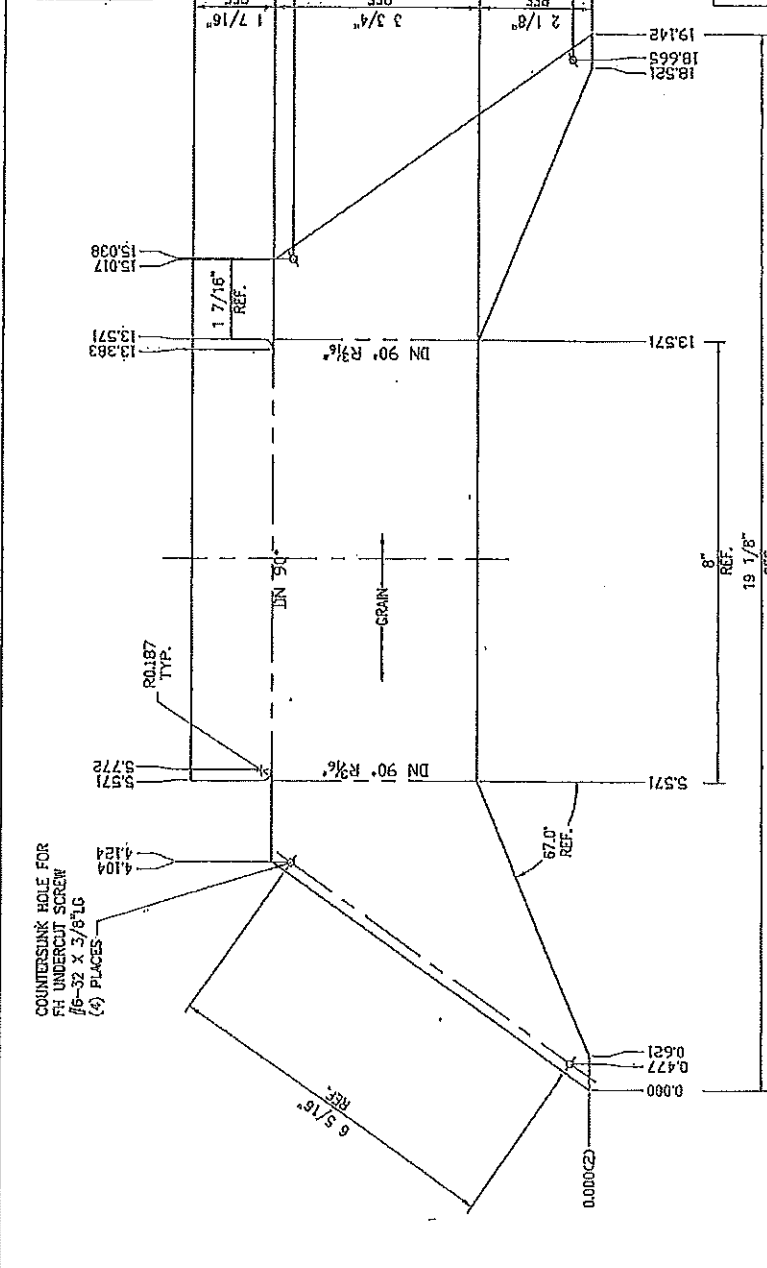

TOLERANCES: (UNLESS OTHERWISE SPECIFIED)  
 #1/16" FRACTIONAL DIMENSIONS DO NOT SCALE DRAWING  
 #1/16" FRACTIONAL ACCUMULATIVE DIMENSIONS CANNOT EXCEED OVER-ALL DIMENSIONS  
 #.010" DIMENSIONS CONTROLLING FINISHED SURFACES  
 #1" ANGULAR DIMENSIONS  
 ALL WELDING TO BE PER J.B. WEBB WELDING SPECIFICATIONS

**Jervis B. Webb Company**  
 WORLD HEADQUARTERS  
 WEBB DRIVE  
 FARRINGTON HILLS, AL 36537-8624

DRAWING TITLE: STAINLESS STEEL READOUT BOX TOP COVER (SHEET 2 OF 3)

DESIGNER	ANIL RINGROZ
APPROVED	JERRY AVO
DATE	08/11/05
SCALE	6" = 1"

USED ON 599-5271-9700X

REV	DATE	BY	REVISION DESCRIPTION
02	11/22/05	RR	REVERSE PLAT PATTERN (WAS)
01	9/16/05	RR	ONE PIECE, NOW MADE FROM ITEMS 1 & 2
00	8/13/05	AVD	TOLERANCE ADDED TO 5 1/2 DIA. (SHT. 3)

DETAIL #1  
 FLAT PATTERN

11/29/05 11:02:28 dringh i:\PROJECT\CONTRACT\B5271\unithml\details\SS readout box (5995271976R2).dwg 3000014 (wzcbcd)

1482



NOTICE: THIS DRAWING INCLUDING THE DESIGN AND PRINCIPLES OF CONSTRUCTION DISCLOSED IS THE PROPERTY OF THE JERVIS B. WEBB COMPANY AND IS SUBMITTED WITH THE UNDERSTANDING THAT IT IS NOT TO BE REPRODUCED, NOR COPIED IN WHOLE OR IN PART, NOR LOANED OR OTHERWISE COMMUNICATED TO ANY THIRD PARTY, NOR USED IN ANY MANNER DETRIMENTAL TO THE JERVIS B. WEBB COMPANY WITHOUT ITS EXPRESS CONSENT.

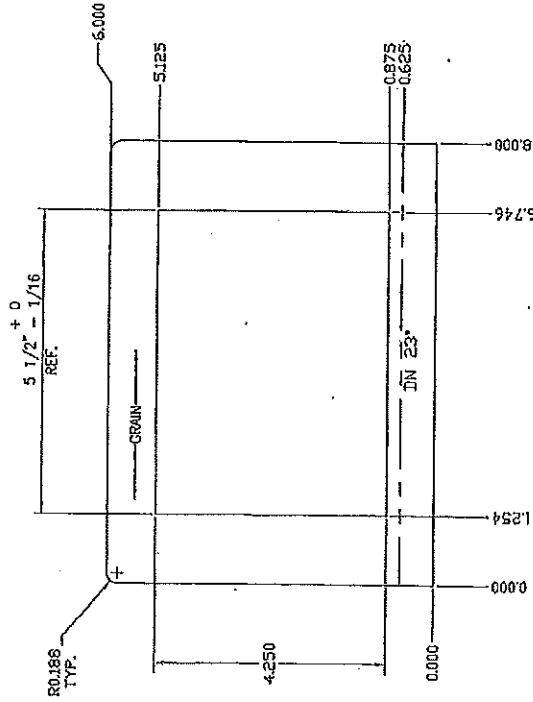

DETAIL #2  
FLAT PATTERN

ITEM NO.	QTY	PART NO.	DESCRIPTION
7		599-5271-976	STAINLESS STEEL READOUT BOX TOP COVER
			SEE SHIT 1 OF 3 FOR BOU

TOLERANCES: (UNLESS OTHERWISE SPECIFIED)  
 DO NOT SCALE DRAWING  
 ±1/16" FRACTIONAL DIMENSIONS  
 ±1.5mm FRACTIONAL ACCUMULATIVE DIMENSIONS  
 ±1/16" CANNOT EXCEED OVER-ALL DIMENSIONS  
 ±.015" DIMENSIONS CONTROLLING FINISHED SURFACES  
 ±.25mm ANGULAR DIMENSIONS  
 ±1° ALL WELDING TO BE PER J.B. WEBB WELDING SPECIFICATIONS



DRAWING TITLE: STAINLESS STEEL READOUT BOX  
 SHEET 3 OF 3  
 DES: R. BRINGHOLZ  
 APPR: [Signature]  
 DATE: 05/11/05  
 SCALE: 5"=1"

REV	DATE	BY	DESCRIPTION
02	11/22/05	RR	USED ON 599-5271-97002
01	9/16/05	RR	ECR#20374: SHIT. 3 OF 3 ADDED
00	6/13/05	AVD	TOLEANCE ADDED TO 5 1/2" DIA.
			RELEASED FOR USE

11/29/05 11:02:32 drringh i:\PROJECT\CONTRACT\95271\unithd\detail\SS readout box\9595271976R2.dwg

62851

NO.	DESCRIPTION	QUANTITY	UNIT	REMARKS
1	CONCRETE			
2	STEEL			
3	GLASS			
4	PAINT			
5	WATER			
6	...			
7	...			
8	...			
9	...			
10	...			
11	...			
12	...			
13	...			
14	...			
15	...			
16	...			
17	...			
18	...			
19	...			
20	...			
21	...			
22	...			
23	...			
24	...			
25	...			
26	...			
27	...			
28	...			
29	...			
30	...			
31	...			
32	...			
33	...			
34	...			
35	...			
36	...			
37	...			
38	...			
39	...			
40	...			
41	...			
42	...			
43	...			
44	...			
45	...			
46	...			
47	...			
48	...			
49	...			
50	...			

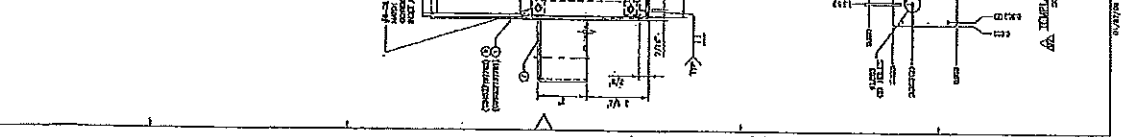
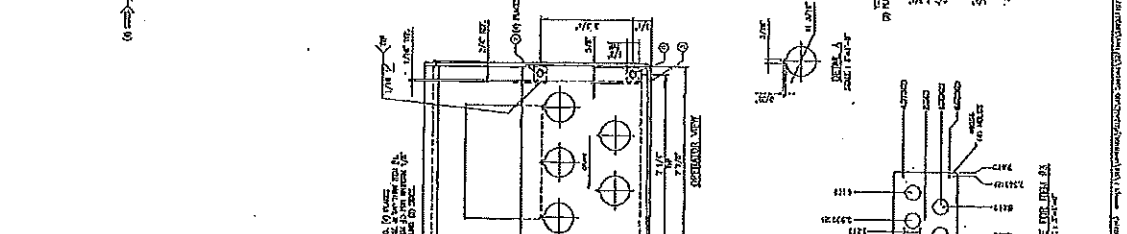
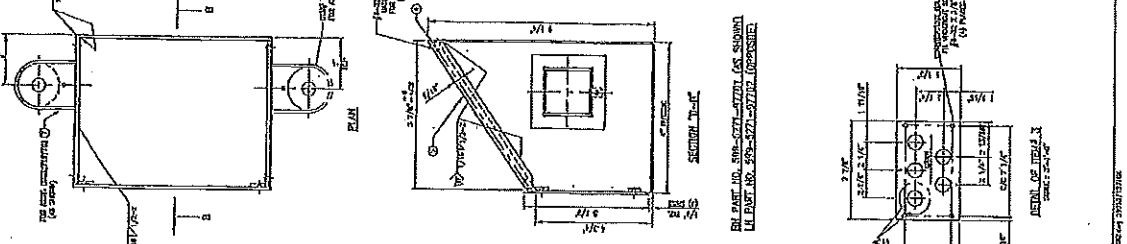
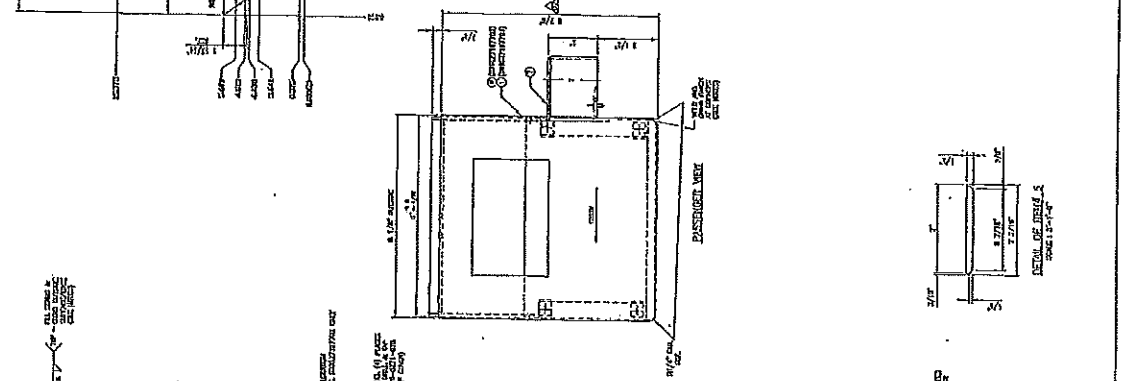
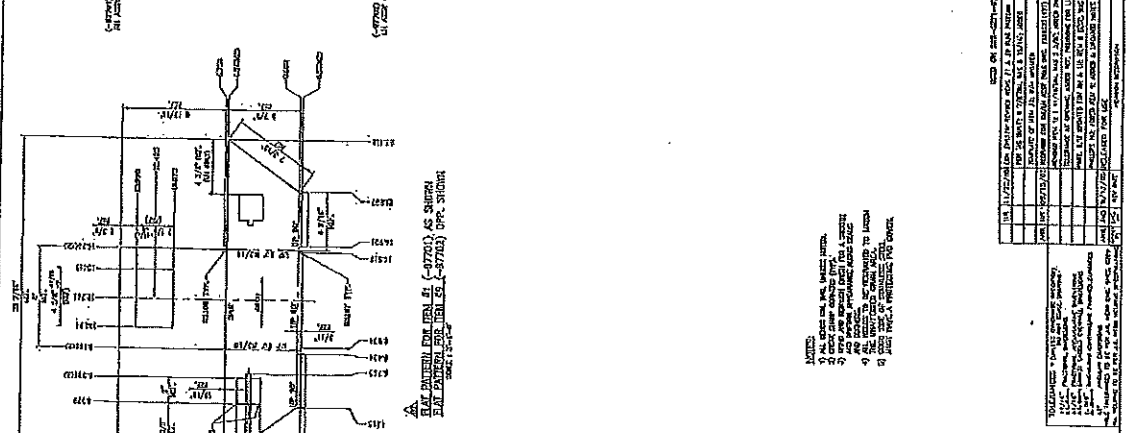

**Yates & Webb Company**  
 1000 Broadway, New York, N.Y.  
 10038

Yates & Webb Company  
 1000 Broadway, New York, N.Y.  
 10038

16 of 29

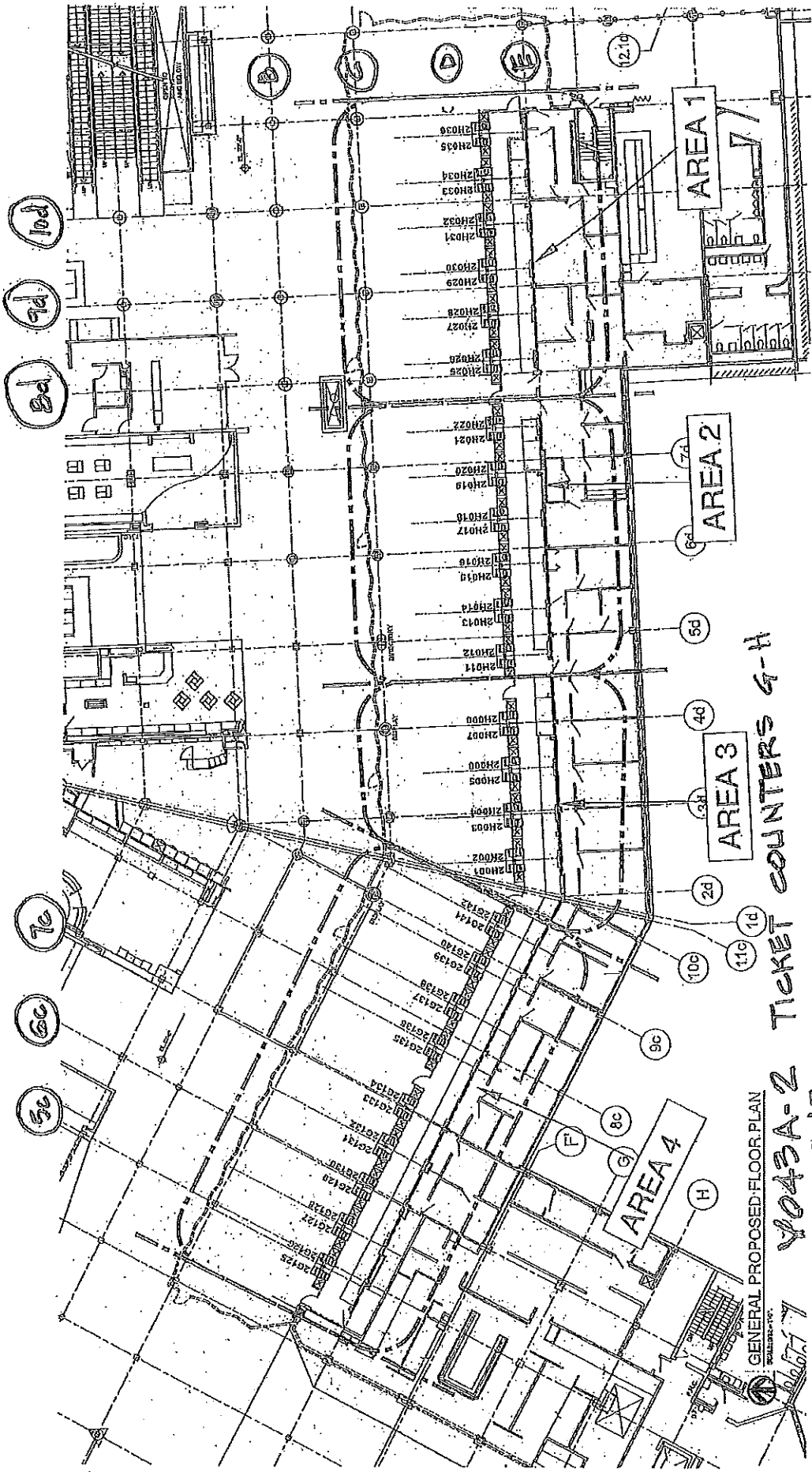

GENERAL PROPOSED FLOOR PLAN  
 Y043A-2 TICKET COUNTERS 4-H

06-22-17  
 EXHIBIT # 1

17 9 29

**Ginny Mirabal**

---

**From:** Gomez, Adriana M. [TOP] (AGomez@miami-airport.com)  
**Sent:** Friday, June 23, 2017 2:39 PM  
**To:** Ginny Mirabal; Leticia Green; Alberto Calderin  
**Cc:** Figueroa, Rebecca (NTD); Negreira, Sergio (Aviation); Barrenechea, Maria [TOP]; Martin, Belinda (TOP)  
**Subject:** MIA Central terminal Ticket Counters G-H Area  
**Attachments:** PPOD-65 Ticket counters G-H Area.pdf

Hi Ginny,

For your information and records, please find attached the Pre-Construction Project Order Draft No. 65 for the project described above.

Thanks,

Adriana G.

Ginny Mirabal

---

**From:** Figueroa, Rebecca (NTD) [RFigueroa@miami-airport.com]  
**Sent:** Tuesday, June 06, 2017 1:57 PM  
**To:** Ginny Mirabal  
**Cc:** Bao-Garciga, Aida (Aviation); Negreira, Sergio (Aviation); Barrenechea, Maria [TOP]; mdeovin@HNTB.com; Martin, Belinda (TOP); Gomez, Adriana M. [TOP]; Johnson, Summer (Aviation)  
**Subject:** RE: V043A-2\_ G-H ticket counter FISH FINDERS Procurement  
**Attachments:** 5271\_fishfinder dwgs.pdf; quote # 22124.pdf

Ginny,

MDAD won't be able to procure and install "Fish finders" for the scales.

Please proceed on the procurement and installation of (44) "Fish finders" for the above mentioned project area.

You should also have on record the procurement and installation cost from the United project.

Thank you,

*Note:*

*JBT already has in storage the other (6) from previous project that will complete the total of 50 for the entire project area.*

## REBECCA FIGUEROA

Project Manager | BeKka group, Inc.  
Miami International Airport | Miami, FL 33159  
O 305.869.3329 | T 305.319.1631

---

**From:** Figueroa, Rebecca (NTD)  
**Sent:** Monday, May 22, 2017 11:39 AM  
**To:** 'Ginny Mirabal'  
**Cc:** Bao-Garciga, Aida (Aviation); Negreira, Sergio (Aviation); Barrenechea, Maria [TOP]; mdeovin@HNTB.com; Martin, Belinda (TOP); Gomez, Adriana M. [TOP]; Johnson, Summer (Aviation)  
**Subject:** RE: V043A-2\_ G-H ticket counter FISH FINDERS Procurement

Hello Ginny,

I understand this is not one of your projects; so now I made the request to MDAD Baggage dpt. to see if they are able to procure the Fish Finders thru one of their existing contracts. We'll keep you informed if we need your further assistance in this issue.

Regards,

**REBECCA FIGUEROA**

Project Manager | BeKka group, Inc.  
Miami International Airport | Miami, FL 33159  
O 305.869.3329 | T 305.319.1631

---

**From:** Ginny Mirabal [mailto:vmirabal@mcm-us.com]  
**Sent:** Monday, May 15, 2017 9:59 AM  
**To:** Figueroa, Rebecca (NTD)  
**Cc:** Bao-Garciga, Aida (Aviation); Negreira, Sergio (Aviation); Barrenechea, Maria [TOP]; mdeovin@HNTB.com; Martin, Belinda (TOP); Gomez, Adriana M. [TOP]  
**Subject:** RE: V043A-2\_ G-H ticket counter FISH FINDERS Procurement

Hi Rebecca,  
When you have a chance, please let's discuss how we will proceed with this directive.

Thanks,

Ginny Mirabal  
PH: 305-541-0000 Ext 230  
DL: 305-869-4563  
M: 305-301-9458  
[www.mcm-us.com](http://www.mcm-us.com)

---

**From:** Figueroa, Rebecca (NTD) [mailto:RFigueroa@miami-airport.com]  
**Sent:** Monday, May 15, 2017 9:27 AM  
**To:** Ginny Mirabal  
**Cc:** Bao-Garciga, Aida (Aviation); Negreira, Sergio (Aviation); Barrenechea, Maria [TOP]; mdeovin@HNTB.com; Martin, Belinda (TOP); Gomez, Adriana M. [TOP]  
**Subject:** V043A-2\_ G-H ticket counter FISH FINDERS Procurement

Ginny,

The above project is in need to procure a total of 44 Fish Finders. Per MDAD direction, please procure Fish Finders as previously done for other project.  
Thank you,

**REBECCA FIGUEROA**

Project Manager | BeKka group, Inc.  
Miami International Airport | Miami, FL 33159  
O 305.869.3329 | T 305.319.1631

*20 8 29*

---

This email has been scanned for spam and viruses by Proofpoint Essentials. Click [here](#) to report this email as spam.

---

Email Scan by McAfee Email Gateway

---

This email has been scanned for spam and viruses by Proofpoint Essentials. Click [here](#) to report this email as spam.



Central Florida:  
 3900 N. Forsyth Rd.  
 Winter Park, FL 32792  
 Phone: 407-679-3133  
 Fax: 407-679-2050

South Florida:  
 3020 SW 38 Ave.  
 Miami, FL 33146  
 Phone: 305-448-0166  
 Fax: 305-441-7136

West Coast Florida:  
 323 Cattleman Rd.  
 Sarasota, FL 34232  
 Phone: 941-377-3400  
 Fax: 941-377-3460

<b>Quote</b>	
Number: 22124	Date: 06-Aug-14

To

JBT SERVICES United States of America
--

Quote To

EDWIN JBT SERVICES United States of America
---

Ph: 305 992 3665

Ph: 305 992 3665

Terms	Ship Via	Salesperson	
		CJ	
Quantity	Description	Unit Price	Amount
	Reference: AIRPORT		
	Line: 001 Part: STAINLESS READOUT BOXES AIRPORT "FISHFINDER" BOXES FABRICATE ONLY:  3 PCS RIGHT HAND BOXES  3 PCS LEFT HAND BOXES  NOTE: 50% DEPOSIT TO START BALANCE DUE @ COMPLETION.  SALES TAX NOT INCLUDED.	Expiration Date: 05-Oct-14 Rev:	
6	ea	\$1,446.00	\$8,676.00
		Total:	\$8,676.00

*22 8 29*





BID SUBMITTAL SIGN-IN SHEET

PROJECT NAME & NO.: MIA - G-H Ticket Counters - FISH Finders - Quick Response P.O. #4

Bid Due DATE/TIME: Wednesday, June 28, 2017 - 2:00PM

Name	Company Name	Phone	E-mail	Signature
Humberto Fleita	Fleitas Constructores G.	Phone: 305-218-4027	humberto@fleitasconstructores.com	[Signature]
DOUDNEY (courses)	DOUDNEY	Phone:		
Humberto Palma	Paradise Awnings Corp	Phone: 305-597-5714	mpalma@paradiseawnings.com	[Signature]
		Phone:		
		Phone:		
		Phone:		
		Phone:		
		Phone:		
		Phone:		
		Phone:		
		Phone:		
		Phone:		
		Phone:		
		Phone:		

23 827



# Successful Bidder(s)



# Un-Successful Bidder(s)



Central Florida:  
 3900 N. Forsyth Rd.  
 Winter Park, FL 32792  
 Phone: 407-679-3133  
 Fax: 407-679-2050

South Florida:  
 3020 SW 38 Ave.  
 Miami, FL 33146  
 Phone: 305-446-0166  
 Fax: 305-441-7136

West Coast Florida:  
 323 Cattlemen Rd.  
 Sarasota, FL 34232  
 Phone: 941-377-3400  
 Fax: 941-377-3460

**Quote**

Number: 26133 Date: 23-Jun-17

To

MCM  
 4301NW 22ND STREET  
 BLDG 3030, 2ND FLOOR  
 MIAMI, FL 33122  
 United States of America

Quote To

GINNY MIRABAL  
 MCM  
 4301NW 22ND STREET  
 BLDG 3030, 2ND FLOOR  
 MIAMI, FL 33122  
 United States of America

Ph: 305 541-0000 EXT 230

Ph: 305 541-0000 EXT 230

Terms		Ship Via	Salesperson
Due On Receipt			CJ
Quantity	Description	Unit Price	Amount
	Reference: FISH FINDERS		
	Line: 001 <span style="float: right;">Expiration Date: 22-Aug-17</span> Part: MIAMI AIRPORT <span style="float: right;">Rev:</span> FISH FINDERS		
	FABRICATION ONLY:		
	(44) FISH FINDER BOXES		
	50% DEPOSIT REQUIRED TO START BALANCE DUE UPON DELIVERY		
	SALES TAX INCLUDED		
	NOTE: DOUDNEY WILL NOT BE RESPONSIBLE FOR ANY DESIGN, ENGINEERING, PERMITTING, BARRICADING OR PEDESTRIAN DIVERSION REQUIRED.		
	DEMO NOT INCLUDED		
1	lot	\$76,120.00	\$76,120.00
		Total:	\$76,120.00

*28829*

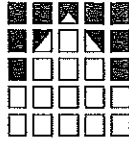

**FLEITES CONSTRUCTION GROUP, INC.**

840 Nightingale Ave  
Miami Springs Florida 33166  
CGC031573

Phone: (305) 216-4027

Fax: (305) 885-3851

E-mail: [humbertofleites621@hotmail.com](mailto:humbertofleites621@hotmail.com) CSBE Cert. No: 13843 DBE Cert. No: 13840  
June 28, 2017

Mr. Alberto Calderin  
MCM  
6201 SW 70<sup>th</sup> Street 2<sup>nd</sup> Floor  
Miami, Florida 33143

**Proposal 44 Stainless Steel Fish Finders**

Dear Mr. Calderin:

This is a proposal for the fabrication of 44 Stainless Steel Fish Finders as drawings by Jarvis Webb Company and requested by MCM. We will deliver 18 units on July 12 and the rest on August 16. The cost is:

**\$147,120.00**

**One Hundred and Forty seven Thousands, One  
Hundred and Twenty.00/100**

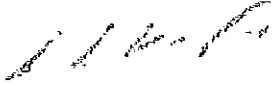
Submitted By:  6/28/2017  
Humberto M. Fleites (Contractor/ Project Manager) Date

Approved by: \_\_\_\_\_ Date \_\_\_\_\_  
Title

*29 of 29*