

PLAN

SCALE: 1- 1/4 " = 1'-0"

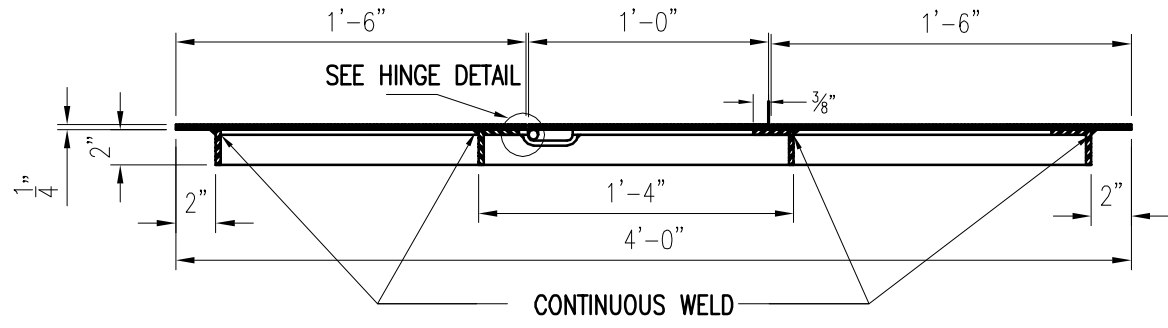

SECTION A

SCALE: 1- 1/4 " = 1'-0"

NOTES:

1. SUPPLIER SHALL PERMANENTLY MARK HIS NAME AND DATE OF MANUFACTURE ON BOTTOM OF EACH COVER BY WELDING, STAMPING OR AS APPROVED BY THE DEPARTMENT
2. ALL WELDS SHALL BE CONTINUOUS.
3. FOLLOWING FABRICATION THE ENTIRE UNIT SHALL BE THOROUGHLY CLEANED AND HOT-DIP GALVANIZED.

XXXXX		
ITEM	CROSS REF.	SPEC. REF.



ISSUE DATE	APPROVED BY
11/01/2006	V. E. F.

STANDARD DETAIL
**STANDARD 2' x 4'
 STEEL COVER PLATE
 FOR NON-TRAFFIC VAULT**

WS
2.17
 SHEET 3 OF 5