

NOTES:

1. Install either a 1/2" Ø x 1" Diameter Threaded Straight (Thru-Bolt), a J-Type, or an adhesive Bonded Anchor Eyebolt.
2. Install a 3/8" Chain and 3/4" Cold Shuts. When chaining two grates together provide adequate loop for easy handling.
3. Install adhesive bonded anchor option with a minimum of 4" embedment, and in accordance with Specification 416.

Index Number	Inlet Type	Eyebolts	Length of Chain	Handling & Remarks
425-030	1	1	4'-0"	Slide & Spin
	2	2	2 @ 4'-0"	Slide & Spin
425-031	N/A	1	3'-8"	Slide or Slide & Spin
425-032	N/A	1	4'-0"	Slide & Spin
425-040	S	1	4'-0"	Slide & Spin
425-041	V	1	4'-0"	Slide & Spin
425-050	A	1	3'-0"	Slide
425-051	B	1	5'-0"	Slide & Spin
	C	1	2'-6"	Slide & Spin
	D	1	2'-6"	Slide & Spin
	E	2	2 @ 2'-6"	Slide & Spin
	H	2	2 @ 2'-6"	Flip Ctr. Grate and Slide & Spin Single Free Grate Center Grate(s) Chained to One End Grate
425-053	F	1	3'-6"	Flip or Slide & Spin
	G	1	6'-0"	Slide
425-054			2'-0"	Lifting Loop
	J	1	4'-0"	Slide & Spin

LOCKING GRATES TO INLETS

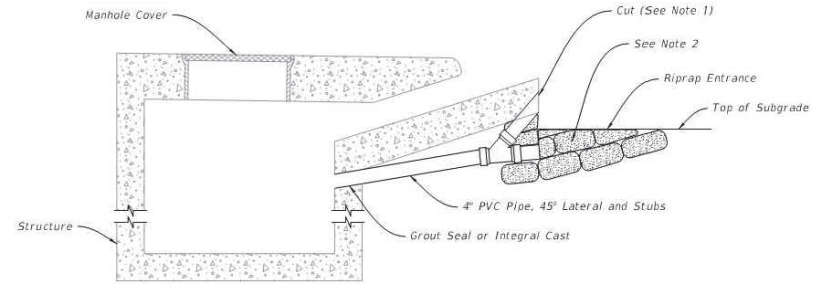

NOTES:

1. Bevel cut upper stub to match forming for apron face. Capping or plugging of upper stub is not required. Remove friable base material at stub opening to permit covering of opening with structural course material.
2. Remove riprap, cement PVC cap on lower stub, and place compacted fill in entrance prior to placing base material.

SUBGRADE AND BASE TEMPORARY DRAINS

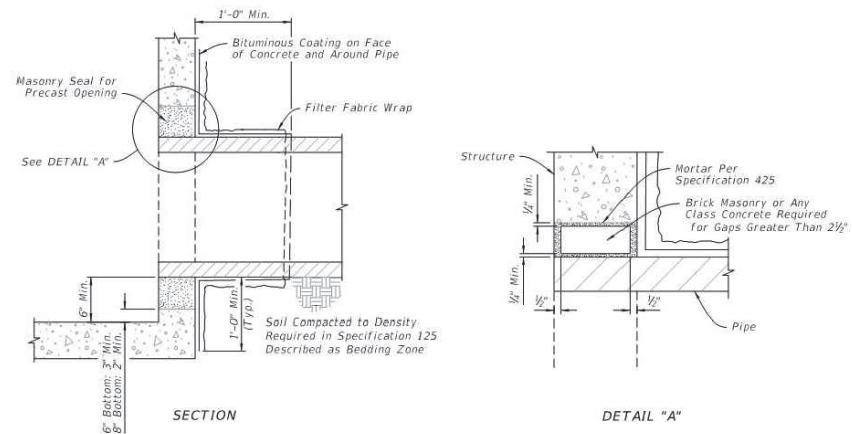

PIPE TO STRUCTURE FILTER FABRIC WRAP

LOCKING GRATES, SUBGRADE AND BASE TEMPORARY DRAINS, AND PIPE TO STRUCTURE FILTER FABRIC WRAP

LAST REVISION 11/01/20	DESCRIPTION:	FDOT	FY 2021-22 STANDARD PLANS	SUPPLEMENTARY DETAILS FOR DRAINAGE STRUCTURES	INDEX 425-001	SHEET 3 of 8
---------------------------	--------------	------	------------------------------	--	------------------	-----------------

REVISIONS					
DATE	BY	DESCRIPTION	DATE	BY	DESCRIPTION

DESIGNED BY: A.K.	NAME: A.K.	DATE: DATE:	DRAWN BY: J.M.	NAME: J.M.	DATE: DATE:
CHECKED BY: L.A.O.	NAME: L.A.O.	DATE: DATE:	CHECKED BY: L.A.O.	NAME: L.A.O.	DATE: DATE:
SUPERVISED BY:					



**SUPPLEMENTARY DETAILS
FOR DRAINAGE STRUCTURES**

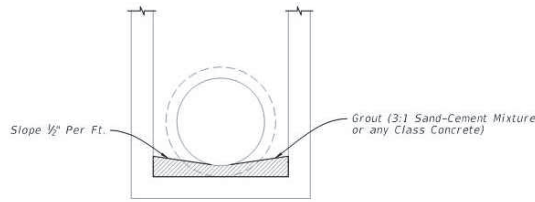

NOTE: For all structures unless excluded by special detail.

DRAINAGE STRUCTURE INVERT

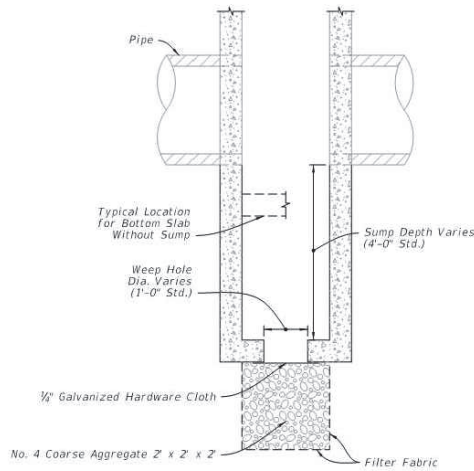

NOTES:

1. Construct sumps in inlets and manholes connecting to French Drains unless excluded in the Plans.
2. Construct sumps only where called for in the Plans at all other locations.
3. Construct weep holes in sump bottom only where called for in the Plans.

SUMP BOTTOM

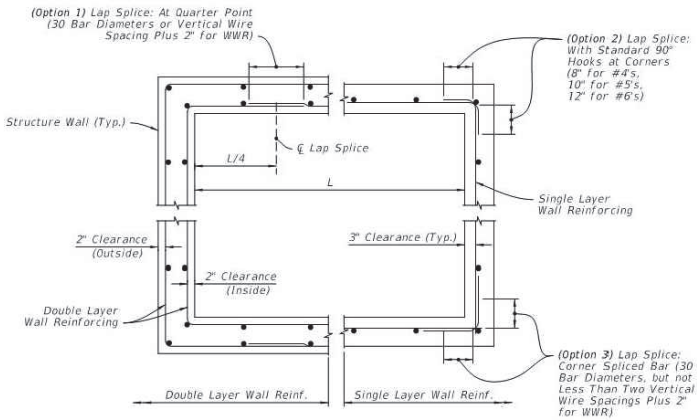

HALF PLAN HALF PLAN

WALL REINFORCING SPLICE DETAILS

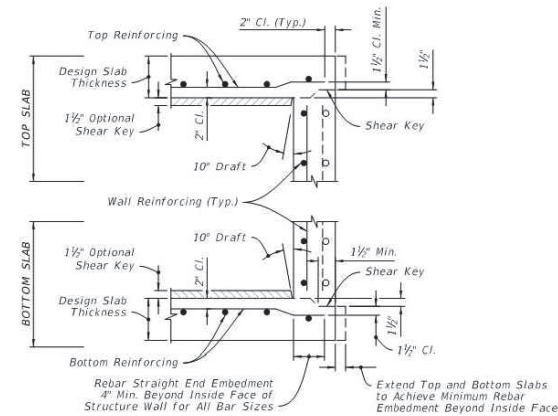

NOTES:

1. See Sheet 6 for optional construction joints.
2. Bend bars as required to maintain cover.

TYPICAL SLAB TO WALL DETAILS
(PRECAST STRUCTURE SHOWN)

DRAINAGE STRUCTURE INVERT, SUMP BOTTOM, WALL REINFORCING SPLICE DETAILS, AND TYPICAL SLAB TO WALL DETAILS

LAST REVISION 11/01/20	DESCRIPTION:	FDOT	FY 2021-22 STANDARD PLANS	SUPPLEMENTARY DETAILS FOR DRAINAGE STRUCTURES	INDEX 425-001	SHEET 4 of 8
---------------------------	--------------	------	------------------------------	--	------------------	-----------------

REVISIONS					
DATE	BY	DESCRIPTION	DATE	BY	DESCRIPTION

DESIGNED BY A.K.	DATE	DRAWN BY J.M.	DATE
CHECKED BY L.A.O.		CHECKED BY L.A.O.	
SUPERVISED BY:			



SUPPLEMENTARY DETAILS FOR DRAINAGE STRUCTURES

P:\My\Planning\Highway\Old Cutler Road - Roundabout\Plan (CAD & PDF files)\CD\10-3D-3D-MD-CMS.dwg Feb 14, 2022 - 1:44pm 2/15/2023

18/11/27/2020 6:42:35 AM

EXAMPLE TABLE OF EQUIVALENT STEEL AREA

SCHEDULE	GRADE 60 REINFORCING BAR		EQUIVALENT GRADE 40 REINFORCING BAR		EQUIVALENT 65 KSI SMOOTH WELDED WIRE REINFORCEMENT		EQUIVALENT 70 KSI DEFORMED WELDED WIRE REINFORCEMENT	
	Bar Size & Spacing	Steel Area (in ² /ft)	Bar Size & Spacing	Steel Area (in ² /ft)	Style Designation	Steel Area (in ² /ft)	Style Designation	Steel Area (in ² /ft)
A	#3 @ 6 1/2" Ctrs. #4 @ 12" Ctrs.	0.20	#3 @ 4 1/2" Ctrs. #4 @ 8" Ctrs. #5 @ 12" Ctrs.	0.30	3"x3"-W4.6xW4.6 4"x4"-W6.2xW6.2 6"x6"-W9.2xW9.2	0.1846	3"x3"-D4.3xD4.3 4"x4"-D5.7xD5.7 6"x6"-D8.6xD8.6	0.1714
B	#3 @ 5 1/2" Ctrs. #4 @ 10" Ctrs.	0.24	#3 @ 3 1/2" Ctrs. #4 @ 6 1/2" Ctrs. #5 @ 10" Ctrs.	0.36	3"x3"-W5.5xW5.5 4"x4"-W7.4xW7.4 6"x6"-W11.1xW11.1	0.2215	3"x3"-D5.1xD5.1 4"x4"-D6.9xD6.9 6"x6"-D10.3xD10.3	0.2057
Special 1	#3 @ 5" Ctrs. #4 @ 9" Ctrs.	0.267	#3 @ 3" Ctrs. #4 @ 6" Ctrs. #5 @ 9" Ctrs.	0.40	3"x3"-W6.2xW6.2 4"x4"-W8.2xW8.2 6"x6"-W12.3xW12.3	0.2465	3"x3"-D5.7xD5.7 4"x4"-D7.6xD7.6 6"x6"-D11.4xD11.4	0.2289
C	#3 @ 3 1/2" Ctrs. #4 @ 6 1/2" Ctrs. #5 @ 10" Ctrs.	0.37	#4 @ 4" Ctrs. #5 @ 6 1/2" Ctrs. #6 @ 9 1/2" Ctrs.	0.555	3"x3"-W8.5xW8.5 4"x4"-W11.4xW11.4 6"x6"-W17.1xW17.1	0.3415	3"x3"-D7.9xD7.9 4"x4"-D10.6xD10.6 6"x6"-D15.9xD15.9	0.3171
D	#4 @ 4 1/2" Ctrs. #5 @ 7" Ctrs. #6 @ 10" Ctrs.	0.53	#4 @ 3" Ctrs. #5 @ 4 1/2" Ctrs. #6 @ 6 1/2" Ctrs.	0.795	3"x3"-W12.2xW12.2 4"x4"-W16.3xW16.3 6"x6"-W24.5xW24.5	0.4892	3"x3"-D11.4xD11.4 4"x4"-D15.1xD15.1 6"x6"-D22.2xD22.2	0.4543
E	#4 @ 3" Ctrs. #5 @ 5" Ctrs. #6 @ 7" Ctrs.	0.73	#5 @ 3 1/2" Ctrs. #6 @ 4 1/2" Ctrs. #7 @ 6 1/2" Ctrs.	1.095	3"x3"-W16.8xW16.8 4"x4"-W22.5xW22.5 6"x6"-W33.7xW33.7	0.6738	3"x3"-D15.6xD15.6 4"x4"-D20.9xD20.9 6"x6"-D31.3xD31.3	0.6257
F	#5 @ 3 1/2" Ctrs. #6 @ 5" Ctrs. #7 @ 7" Ctrs.	1.06	#6 @ 3" Ctrs. #7 @ 4 1/2" Ctrs. #8 @ 6" Ctrs.	1.59	3"x3"-W24.5xW24.5 4"x4"-W32.6xW32.6 6"x6"-W48.9xW48.9	0.9785	3"x3"-D22.7xD22.7 4"x4"-D30.3xD30.3 6"x6"-D45.3xD45.3	0.9086
Special 2	#5 @ 3" Ctrs. #6 @ 4" Ctrs. #7 @ 5 1/2" Ctrs.	1.24	#7 @ 4" Ctrs. #8 @ 5" Ctrs.	1.86	3"x3"-W28.6xW28.6 4"x4"-W38.2xW38.2 6"x6"-W57.2xW57.2	1.1446	3"x3"-D26.6xD26.6 4"x4"-D35.4xD35.4 6"x6"-D53.1xD53.1	1.0629
G	#6 @ 3 1/2" Ctrs. #7 @ 5" Ctrs.	1.46	#7 @ 3" Ctrs. #8 @ 4" Ctrs.	2.19	3"x3"-W33.7xW33.7 4"x4"-W44.9xW44.9	1.3477	3"x3"-D31.3xD31.3 4"x4"-D41.7xD41.7	1.2514

NOTES:

- See inlet indexes for optional precast inlet construction details up to depths of 15'.
- Interior dimensions of an Alt. "B" Bottom may be adjusted to reflect these inlet interior dimensions when precast units are used in conjunction with Alt. "B" Structure Bottoms, Index 425-010.
- Use concrete meeting the requirements of ASTM C478 or Class IV for precast structures with 6" wall or slab thickness.
- Reinforcement may be deformed bar reinforcement or welded wire reinforcement. Bar reinforcement other than 60 ksi may be used, however only two grades are recognized: Grade 40 and Grade 60. Smooth welded wire reinforcement will be recognized as having a design strength of 65 ksi and deformed welded wire reinforcement will be recognized as having a design strength of 70 ksi. The area of reinforcement required may be adjusted in accordance with the Equivalent Steel Area Table provided. Use the following equations to determine the steel area and spacing for bars; not otherwise specified:
Grade 40 Steel Area = $A_{s40} = 60/40 \times A_{s60}$
Smooth Welded Wire Reinforcement Steel Area = $A_{s65} = 60/65 \times A_{s60}$
Deformed Welded Wire Reinforcement Steel Area = $A_{s70} = 60/70 \times A_{s60}$
When a reduced area of reinforcement is provided, any maximum bar spacing shown must also be reduced as determined by the following equations, unless otherwise shown:
Max. Grade 40 Bar Spacing = Grade 60 Bar Spacing
Max. Smooth Welded Wire Spacing = Grade 60 Bar Spacing x 0.86
Max. Deformed Welded Wire Spacing = Grade 60 Bar Spacing x 0.74
When an increased area of reinforcing is provided, the maximum bar spacing may be increased by the squared ration of increased steel area, but not to exceed 12":
Max. Bar Spacing Provided \leq Max. Bar Spacing Required $\times \left(\frac{\text{Steel Area Provided}}{\text{Min. Steel Area Required}} \right)^2$
Use wire no smaller than W3.1 or D4.0, or larger and with spacing 8" or less. Use bar reinforcement displaying the minimum yield designation grade mark, or either the number 60 or one (1) grade mark line to be acceptable at the higher value. Use maximum bar spacing no greater than two (2) times the slab thickness with a maximum spacing of 12" or three (3) times the wall thickness, with a maximum spacing of 18" for vertical bars and 12" for horizontal bars. Wires smaller than W3.1 or D4.0 may be used in the walls of ASTM C 478 round structure bottoms and round risers.
- Fiber-reinforced concrete may be substituted for conventional steel reinforcement in accordance with the Structures Design Guidelines. Submit shop drawings corresponding to an approved fiber-reinforced concrete mix design for approval to the State Drainage Engineer.

PRECAST OPTION AND EQUIVALENT REINFORCEMENT SUBSTITUTION

LAST REVISION 11/01/20	DESCRIPTION:		FY 2021-22 STANDARD PLANS	SUPPLEMENTARY DETAILS FOR DRAINAGE STRUCTURES	INDEX 425-001	SHEET 5 of 8
---------------------------	--------------	---	------------------------------	--	------------------	-----------------

REVISIONS					
DATE	BY	DESCRIPTION	DATE	BY	DESCRIPTION

DESIGNED BY A.K.	NAME A.K.	DATE	DRAWN BY J.M.	NAME J.M.	DATE
CHECKED BY L.A.O.	NAME L.A.O.		CHECKED BY L.A.O.	NAME L.A.O.	
SUPERVISED BY:					



**SUPPLEMENTARY DETAILS
FOR DRAINAGE STRUCTURES**

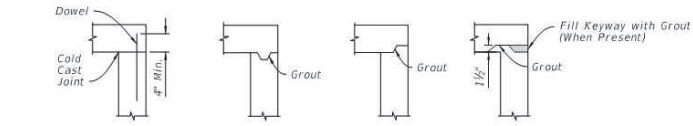

TOP SLABS TO WALL JOINTS

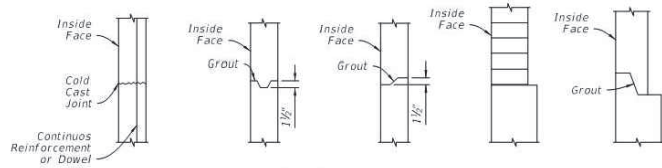

WALL JOINTS

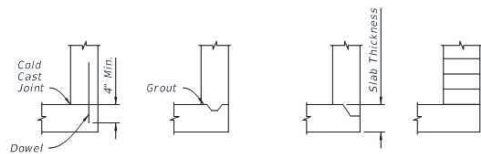

BOTTOM SLAB TO WALL JOINTS

NOTES:

- One or more types of joints may be used in a single structure, except brick wall structure. Brick wall construction is permitted on circular units only.
- All grouted joints are to have a maximum thickness of 1".
- Keyways are to be a minimum of 1 1/2" deep.
- Joint dowels are to be #4 bars, 12" long with a minimum of 6 bars per joint approximately evenly spaced for circular structures or at maximum 12" spacing for rectangular structures. Bars may be either Adhesive Bonded Dowels in accordance with Specification 416, or placed approximately 6" into fresh concrete leaving the remainder to extend into the secondary cast. Welded wire reinforcement may be substituted for the dowel bar in accordance with the equivalent steel area table on Sheet 5.
- Minimum cover on dowel reinforcing bars is 2" to outside face of structure.
- Seal joints between wall segments and between wall segments and top or bottom slabs with preformed plastic gasket material in accordance with Specification 430 or non-shrink grout in accordance with Specification 934.
- Insert products approved by the Engineer may be used in lieu of dowel embedment.

CONSTRUCTION JOINT OPTIONS

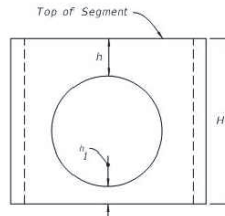

When $6" \leq h_1 < 0.75H$ (Min.)
 $h_1 \geq 0.75H$ (Min.)

Then (Req.)
 $h \geq 0.4H$
 $h \geq H$ (Min.)

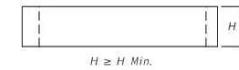
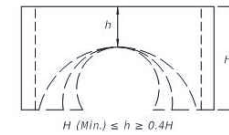

$H \geq H$ Min.

TABLE 3
Minimum Value for H

H (min.)	Box or Riser Diameter
1'-0"	3'-6" & 4'-0"
1'-6"	5'-0" & 6'-0"
2'-0"	>6'-0"

NOTES:

- Segments may be inverted. Opening for pipe is the pipe OD plus 6" ($\pm 2"$ tolerance).
- If h can not be attained, then a top or bottom slab must be attached to the segment as shown below.

RISER SEGMENTS OTHER THAN DOWEL

Riser or Inlet Opening (Location Varies)

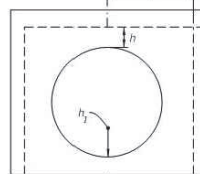

$h \geq \text{zero}$ and $h_1 \geq 6"$

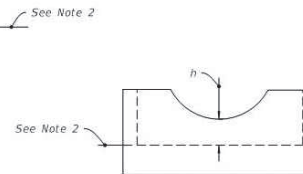

Top or Bottom Segment:
 $h \geq 2"$

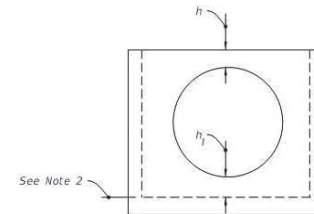

$h_1 \geq 2"$ and $h \geq 6"$

NOTES:

- h may be less than 6" when approved by the Engineer, but not for inlet segments at finish grade elevation.
- Dowel construction joint or monolithic cast only.

SEGMENTS FOR SLAB TO WALL DOWEL CONSTRUCTION JOINTS OR MONOLITHIC CAST

MINIMUM BOX AND RISER SEGMENT DIMENSIONS

CONSTRUCTION JOINT OPTIONS AND MINIMUM BOX AND RISER SEGMENT DIMENSIONS

LAST REVISION	DESCRIPTION:
11/01/20	

FDOT
 FY 2021-22
 STANDARD PLANS

SUPPLEMENTARY DETAILS
 FOR DRAINAGE STRUCTURES

INDEX SHEET
 425-001 6 of 8

P:\My\Projects\Highway\Old Cutler Road - Roundabout\Plan (CAD & PDF files)\CD\10-3D-3D-MDI-CMS\dwg Feb 14, 2022 - 1:44pm E211983

18/12/2020 6:42:40 AM

REVISIONS			
DATE	BY	DESCRIPTION	DATE

DESIGNED BY	NAME	DATE	DRAWN BY	NAME	DATE
	A.K.			J.M.	
	L.A.O.			L.A.O.	

DEPARTMENT OF TRANSPORTATION AND PUBLIC WORKS
 HIGHWAY DIVISION
MIAMI-DADE COUNTY
 CORNER S. CLAY CENTER
 100 W. OF
 MIAMI, FLORIDA 33138

**SUPPLEMENTARY DETAILS
 FOR DRAINAGE STRUCTURES**

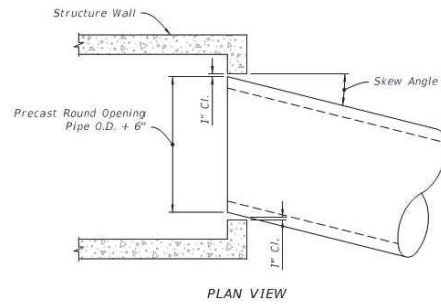
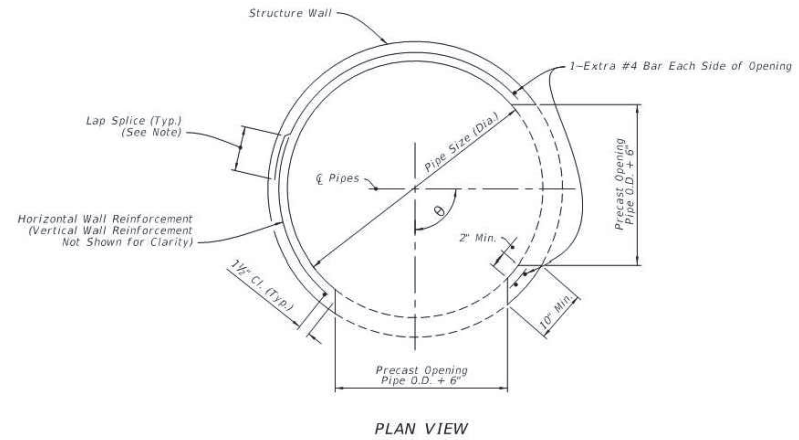

TABLE 4 - MAXIMUM PIPE SKEW FOR PRECAST ROUND OPENINGS

WALL THICKNESS	PIPE SIZE												
	18"	24"	30"	36"	42"	48"	54"	60"	66"	72"	78"	84"	
MAXIMUM SKEW ANGLE	8°	19°	17°	16°	16°	15°	14°	14°	13°	13°	13°	12°	12°
	6°	21°	20°	18°	17°	17°	16°	15°	15°	14°	14°	13°	13°

NOTE:
 These values are based on 2" clearance for precast structures. Larger skews are possible for Cast-in-Place Structures or elliptical pipe openings when approved by the Engineer.

MAXIMUM PIPE SKEW FOR PRECAST ROUND OPENINGS



NOTE:
 Lap splice: 20 bar diameter for deformed wire or bar, but not less than vertical wire spacing plus 2" for WWR or 40 bar diameters for smooth wire.

MULTIPLE PIPE CONNECTIONS - PRECAST ROUND STRUCTURES

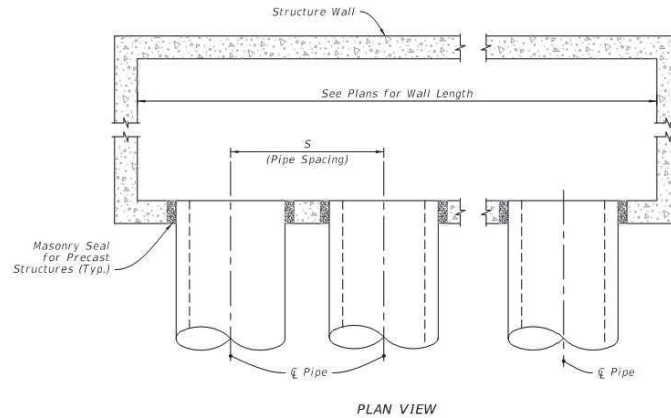

MULTIPLE PARALLEL PIPE CONNECTIONS - RECTANGULAR STRUCTURES

TABLE 5 - MINIMUM SIZES FOR MULTIPLE PARALLEL PIPE CONNECTIONS

PIPE SIZE	PIPE SPACING (S)
18"	2'-10"
24"	3'-5"
30"	4'-3"
36"	5'-1"
42"	6'-0"
48"	6'-9"
54"	7'-8"
60"	8'-6"
66"	9'-0"
72"	10'-0"
78"	10'-9"
84"	11'-8"

MISCELLANEOUS PIPE CONNECTION DETAILS

LAST REVISION 11/01/20	DESCRIPTION:	FY 2021-22 STANDARD PLANS	SUPPLEMENTARY DETAILS FOR DRAINAGE STRUCTURES	INDEX 425-001	SHEET 8 of 8
---------------------------	--------------	------------------------------	--	------------------	-----------------

R E V I S I O N S

DATE	BY	DESCRIPTION	DATE	BY	DESCRIPTION

DESIGNED BY: A.K.	NAME: J.M.	DATE:	DRAWN BY: L.A.O.	NAME:	DATE:
CHECKED BY:	L.A.O.		CHECKED BY:	L.A.O.	
DEPARTMENT OF TRANSPORTATION AND PUBLIC WORKS HIGHWAY DIVISION STEPHEN P. CLARK CENTER 100 N.W. 1 ST AVENUE MIAMI, FLORIDA 33138					

SUPPLEMENTARY DETAILS FOR DRAINAGE STRUCTURES

P:\My\Drawings\Highway\Old Cutler Road - Roundabouts\Plan (CAD & PDF files)\CAD\10-25D-MDC-DMS\04g Feb 14, 2022 - 1:44pm E215983

18/11/2020 9:32:10 AM

REV.	DATE	DESCRIPTION	BY
1	10/21/20	REVISED	L.M.F.

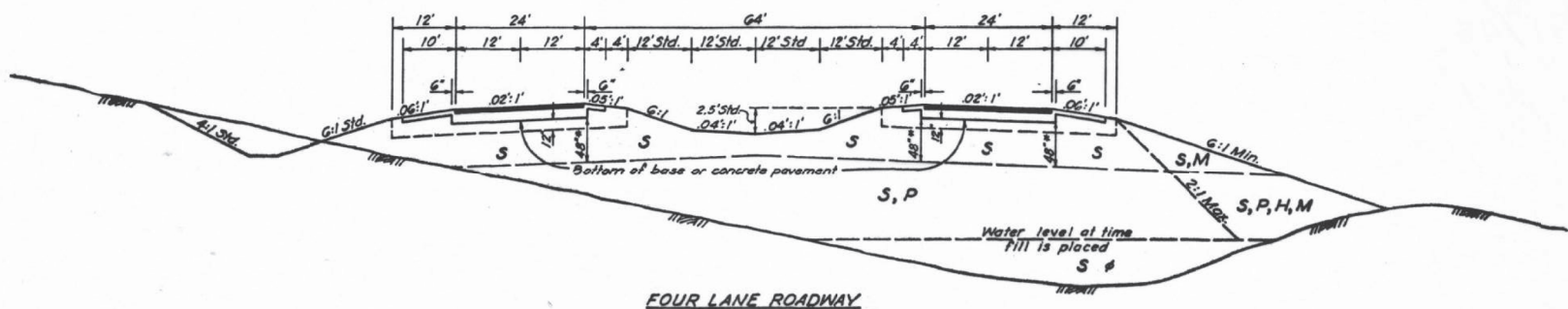

FOUR LANE ROADWAY

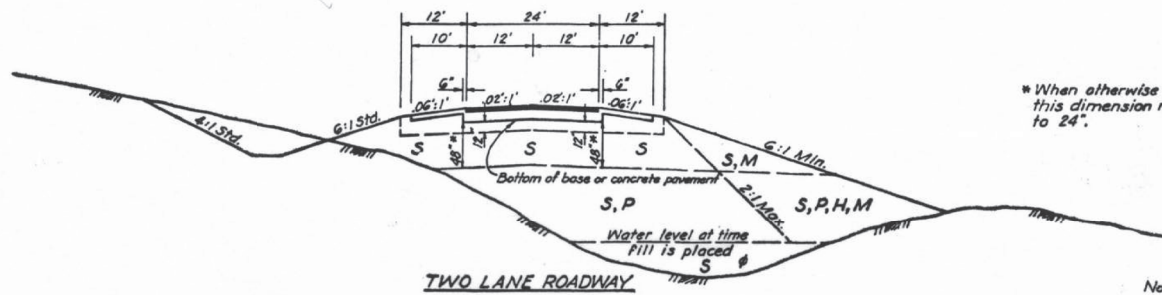

TWO LANE ROADWAY

* When otherwise shown on plans this dimension may be reduced to 24".

Note: All dimensions shown are standard.
The details shown on this Index drawing do not supersede the details shown on Index GAC-01.

SYMBOL	SOIL	CLASSIFICATION*
S	Select	A-1, A-3, A-2-4
P	Plastic	A-2-5, A-2-6, A-2-7, A-4, A-5, A-6, A-7 (All with LL < 50)
H	High Plastic	A-5 or A-7 (both with LL > 50)
M	Muck	A-8

Symbols listed L to R in order of preference.
* AASHTO Soil Classification System (AASHTO - M-145)
† Certain types of A-2-4 material are likely to retain excess moisture and may be difficult to dry and therefore should be used in the embankment above water level existing at time of construction.

FHWA APPROVED: 4-23-74 39

STATE OF FLORIDA DEPARTMENT OF TRANSPORTATION
ROADWAY PLANS SECTION

EMBANKMENT UTILIZATION DETAILS

REVISED	ROAD NO.	COUNTY	PROJECT NO.
None			
Drawn by	Checked by	Reviewed by	Approved by
L.M.F.			
10-28			
10/21/20			
10/21			

REVISIONS			
DATE	BY	DESCRIPTION	

DESIGNED BY	NAME	DATE	DRAWN BY	NAME	DATE
	A.K.		J.M.		
	L.A.O.		L.A.O.		

MIAMI-DADE COUNTY
DEPARTMENT OF TRANSPORTATION AND PUBLIC WORKS
HIGHWAY DIVISION
STEPHEN P. CLAY CENTER
100 N. E. 10th St.
MIAMI, FLORIDA 33132

EMBANKMENT UTILIZATION DETAILS

REV. NO.	DATE	BY	DESCRIPTION
3	FLA.		

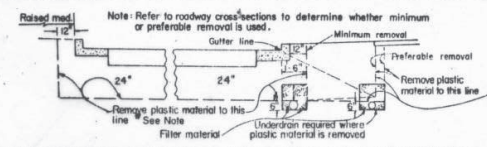

NOTE: Where frequency of median breaks indicates that it is impractical to leave plastic material in the median, the designer may elect to indicate total removal of this material. If during construction it becomes apparent, due to normal required construction procedures, that it is impractical to leave the plastic material in the median, the project engineer may authorize total removal of this material after clearing this change thru the Asst. Dist. Engr. - Const.

HALF SECTION SHOWING REMOVAL OF PLASTIC MATERIAL AND LOCATION OF UNDERDRAIN IN MUNICIPAL CONST.

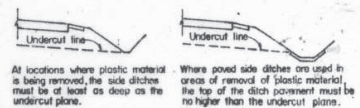

MISCELLANEOUS DETAILS

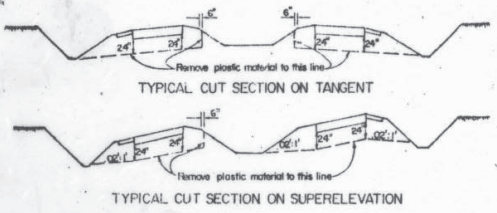

TYPICAL SECTIONS FOR REMOVAL OF PLASTIC MATERIAL ON INTERSTATE AND PRIMARY SYSTEM HAVING DEPRESSED MEDIAN

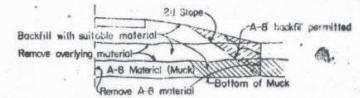
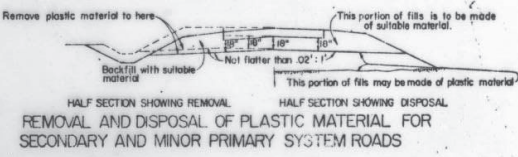
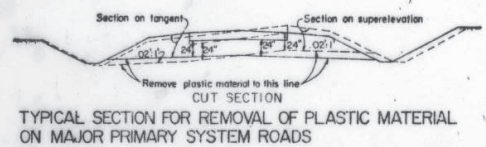

HALF SECTION SHOWING REMOVAL AND DISPOSAL OF A-B MATERIAL IN RURAL CONSTRUCTION

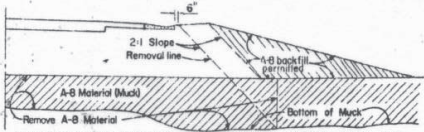

HALF SECTION SHOWING MUCK REMOVAL WHERE SHOULDER GUTTER IS CONSTRUCTED

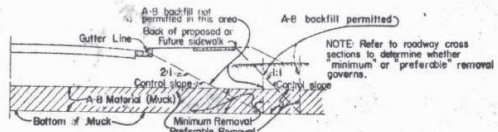

HALF SECTION SHOWING REMOVAL AND DISPOSAL OF A-B MATERIAL IN MUNICIPAL CONSTRUCTION

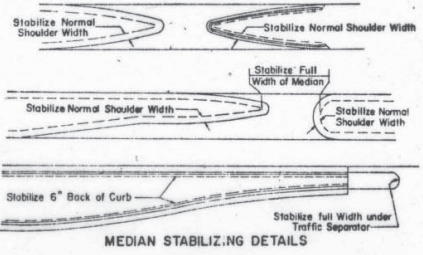

GENERAL STABILIZING NOTES:

- When typical section has curb or gutter in median stabilize 6" back of curb.
- When typical section has shoulder with no curb or gutter in median stabilize to normal shoulder width.
- Stabilize entire area under all paved traffic lanes.
- Stabilize full width under all traffic separators.

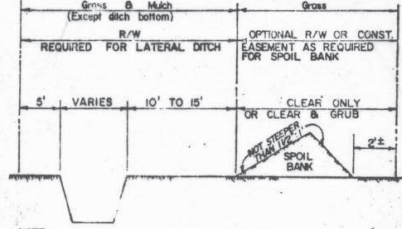

- NOTE:
- Where no spoil is anticipated or when a large ditch or canal is involved and spoil is anticipated on both sides, 1:1 fill should be adjusted accordingly.
 - Cleaning and Grubbing is to extend 200' beyond the end of the ditch if necessary.
 - The bottom width of Lateral Ditches is to be 2' wider than the span of the Structure they drain or as shown on Plans.
 - No Spoil Bank will be permitted within 300' of the E. of the Project, measured at right angles thereto. Waste materials in this section shall be either hauled and deposited in areas approved by the Engineer, or spread on adjacent areas to the depth designated by the Engineer.
 - All excavation from Lateral Ditches shall be wasted unless otherwise shown on Lateral Ditch Sheets.

TYPICAL SECTION LATERAL DITCH SHOWING SPOIL BANK

GENERAL NOTES

- Minimum grade on underdrain pipe shall be 0.2%.
- Gradation of the filter material shall conform to standard specifications.
- In rural projects, where underdrain is to be constructed beneath the proposed pavement, the grade of the underdrain is to be such that the underdrain filter material will not extend above the bottom of the stabilized section of the subgrade.
- All details shown on this sheet for the removal and disposal of unsuitable materials apply unless otherwise shown on the plans.
- Where plastic material is undercut, backfill shall be made of suitable material.
- The term "plastic material" used in this drawing in conjunction with removal of plastic material is defined as any material of the soils classifications of A-2-6, A-2-7, A-4, A-5, A-6 and A-7.
- The normal depth of side ditches for Interstate and major Primary System roads shall be 3:3' below the shoulder point except in special cases.
- On Primary and Interstate highways where plastic material is permitted for use in roadway fill, the material may be placed above the existing water level (at the time of Construction) to within 4" of the proposed base. It should be placed uniformly in the lower portion of the embankment for some distance along the Project rather than full depth for short distances.

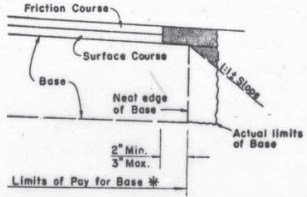

DETAIL FOR REMOVAL OF EXCESS BASE MATERIAL

- NOTES:
- All surplus material in shaded area to be removed.
 - Payment for removal is included in the Base Item.
 - Area of base for payment will be calculated using the nominal width (3" Overhang).

58

FHWA Approved: 7-7-75

STATE OF FLORIDA DEPARTMENT OF TRANSPORTATION
 ROADWAY PLANS SECTION

MISC. ROADWAY CONSTRUCTION DETAILS

REVISIONS	ROAD NO.	COUNTY	PROJECT NO.
10-74 (Redrawn Under No Change)			
8-75 (Added Detail for Removal of Excess Base Material)			
Prepared by:	Name:	Date:	Approved by:
Checked by:			
Reviewed by:			
Drawn by:			
Quantity by:			
Checked by:			
Reviewed by:			

1 of 2 GRC-01-I

REVISIONS

DATE	BY	DESCRIPTION	DATE	BY	DESCRIPTION

DESIGNED BY	NAME	DATE	DRAWN BY	NAME	DATE
	A.K.		J.M.		
CHECKED BY	NAME	DATE	CHECKED BY	NAME	DATE
	L.O.		L.O.		

DEPARTMENT OF TRANSPORTATION AND PUBLIC WORKS
 HIGHWAY DIVISION
 MIAMI-DADE COUNTY
 MIAMI, FLORIDA 33138

MISC. ROADWAY CONSTRUCTION DETAILS

P:\Miami\Highway\Old Cutler Road - Roundabout\Plan (CAD & PDF files)\CAD\10-75-35-300-CMS-089-Plan Feb 14, 2002 - 1:46pm 12/19/83

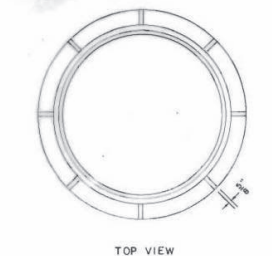

TOP VIEW

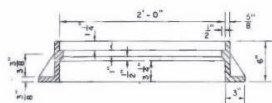

SECTION
TYPE I
FOR MANHOLES

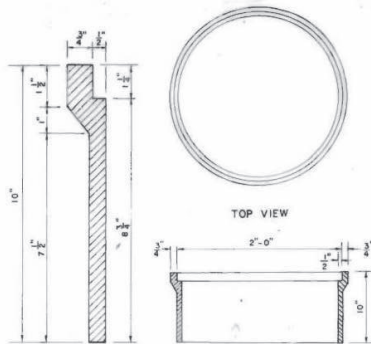

TOP VIEW

WALL SECTION SECTION
TYPE II
FOR CURB INLETS TYPES 1, 2, 3, & 4

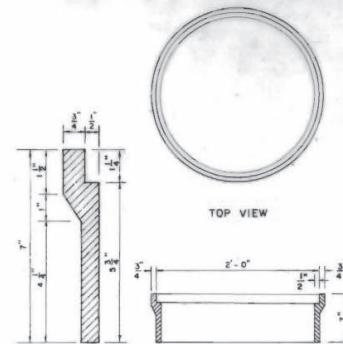

TOP VIEW

WALL SECTION SECTION
TYPE III
FOR CURB INLETS TYPES 7 & 8

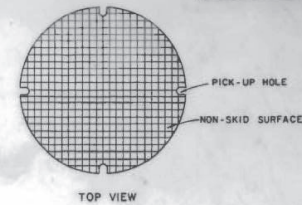

TOP VIEW



BOTTOM VIEW

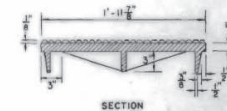

SECTION
COVER FOR ALL FRAMES

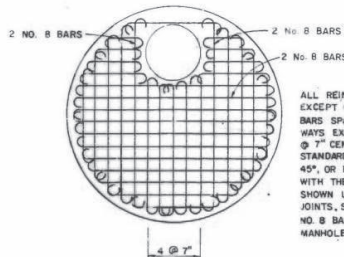

REINFORCEMENT PLAN

ALL REINFORCEMENT NO. 6 BARS EXCEPT 6 NO. 8 BARS SHOWN. BARS SPACED @ 6" CENTERS BOTH WAYS EXCEPT MIDDLE BARS SHOWN @ 7" CENTERS. ALL BARS WITH A.C.I. STANDARD HOOKS CANTED APPROX. 45°, OR EMBEDDED IN ACCORDANCE WITH THE SLAB REINFORCEMENT DETAIL SHOWN UNDER OPTIONAL CONSTRUCTION JOINTS, SHEET NO. 2&2 EXCEPT ALL NO. 8 BARS AND NO. 6 BARS AROUND MANHOLE OPENING SHALL BE HOOKED.

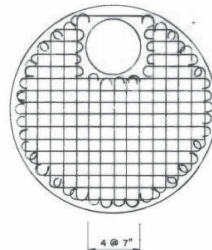

REINFORCEMENT PLAN

REINFORCING BARS @ 6" CENTERS BOTH WAYS EXCEPT MIDDLE BARS SHOWN @ 7" CENTERS. ALL BARS WITH A.C.I. STANDARD HOOKS CANTED APPROX. 45°, OR EMBEDDED IN ACCORDANCE WITH THE SLAB REINFORCEMENT DETAIL SHOWN UNDER OPTIONAL CONSTRUCTION JOINTS, SHEET 3 OF 3, EXCEPT BARS AROUND MANHOLE OPENING SHALL BE HOOKED.

BAR SIZE	TOP DIAMETER
No. 4	3'-6" & 4'
No. 5	6"
No. 6	7"

NOTES (TOPS, FRAMES AND COVER):

- ALL STEEL BARS SHALL BE NEW BARS IN ACCORDANCE WITH ASTM A615, GRADE 60 AND HAVE 1/2" MINIMUM COVER UNLESS OTHERWISE SHOWN AND SHALL BE HOOKED WHERE INDICATED.
- MANHOLE TOP TYPE 7 SLABS SHALL BE OF CLASS II CONCRETE (f'c = 3400 P.S.I.).
- MANHOLE TOP TYPE 7 SLABS MAY BE OF CAST-IN-PLACE OR PRECAST CONSTRUCTION. THE OPTIONAL KEY IS FOR PRECAST TOPS AND IN LIEU OF DOWELS. FRAME AND SLAB OPENINGS ARE TO BE OMITTED WHEN TOP IS USED OVER A JUNCTION BOX. FRAMES CAN BE ADJUSTED WITH FROM ONE TO SIX COURSES OF BRICK.
- MANHOLE TOP TYPE 8 MAY BE OF CAST-IN-PLACE OR PRECAST CONCRETE CONSTRUCTION OR BRICK CONSTRUCTION. FOR CONCRETE CONSTRUCTION, THE CONCRETE AND STEEL REINFORCEMENT SHALL BE THE SAME AS THE SUPPORTING WALL UNIT. AN ECCENTRIC CONE MAY BE USED.
- MANHOLE TOPS SHALL BE SECURED TO STRUCTURES BY OPTIONAL CONSTRUCTION JOINTS AS SHOWN ON SHEET NO. 2 OF THIS DETAIL.
- ALL COVERS TO BE TACK WELDED TO FRAMES AT THIRD POINTS OR GROUDED AT THIRD POINTS WITH EPOXY (TOTAL ELEVEN (11) OUNCES OF MIXED EPOXY).
- THE 212 LB. COVER IS THE REPLACEMENT FOR ALL PREVIOUS 174" DEEP FRAMES (TRAFFIC TYPE). THE 185 LB. COVER IS THE REPLACEMENT FOR ALL PREVIOUS 1/2" DEEP FRAMES (NON-TRAFFIC TYPE).

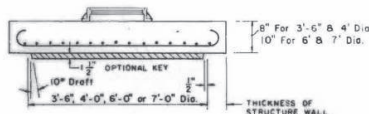

SECTION
TYPE 7-T (TRAFFIC) (H-20)

MANHOLES OR JUNCTION BOXES

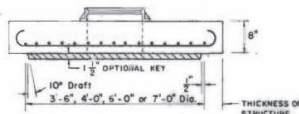

SECTION
TYPE 7-NT (NON-TRAFFIC)

STRUCTURE TOPS

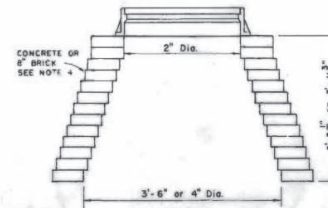

SECTION
TYPE 8
MANHOLES

WEIGHT OF CASTINGS	
TYPE I	126 Lbs.
TYPE II	134 Lbs.
TYPE III	98 Lbs.
COVER	212 Lbs.

32

DADE COUNTY PUBLIC WORKS DEPARTMENT
HIGHWAY DIVISION

DESIGN S.B.D.
DRAWN F.B.
CHECKED W. Blum
PROPOSED BY W. Blum
DATE NOV 1983

SUPPLEMENTARY DETAILS FOR
MANHOLES AND INLETS

SMI-1

APPROVED

SHEET 35 OF 35

REVISIONS					
DATE	BY	DESCRIPTION	DATE	BY	DESCRIPTION

DESIGNED BY	NAME	DATE	DRAWN BY	NAME	DATE
	A.K.			J.M.	
	L.O.			L.O.	

DEPARTMENT OF TRANSPORTATION
AND PUBLIC WORKS
HIGHWAY DIVISION

MIAMI-DADE COUNTY

SPINER P. CLAY CENTER
MIAMI, FLORIDA 33138

SUPPLEMENTARY DETAILS FOR
MANHOLES AND INLETS

GENERAL NOTES:

1. Work this Index with Index 425-001 and Index 425-010.
2. Conform finished grade and slope of the Inlet Tops to the finished cross slope and grade of the adjacent sidewalk and/or border.
3. Provide 1 1/2" minimum cover for steel in the Inlet Top.
4. Construction of Inlet Tops are either precast or cast-in-place.
5. For precast units, the rear wall and apron may be precast as a separate piece from the top slab. Provide a minimum of 7 - #4 dowels, otherwise install in accordance with Index 425-001 "OPTIONAL CONSTRUCTION JOINTS".
6. These inlets are designed for use with standard curb and gutter Type E and Type F.
7. Use only round concrete support posts.

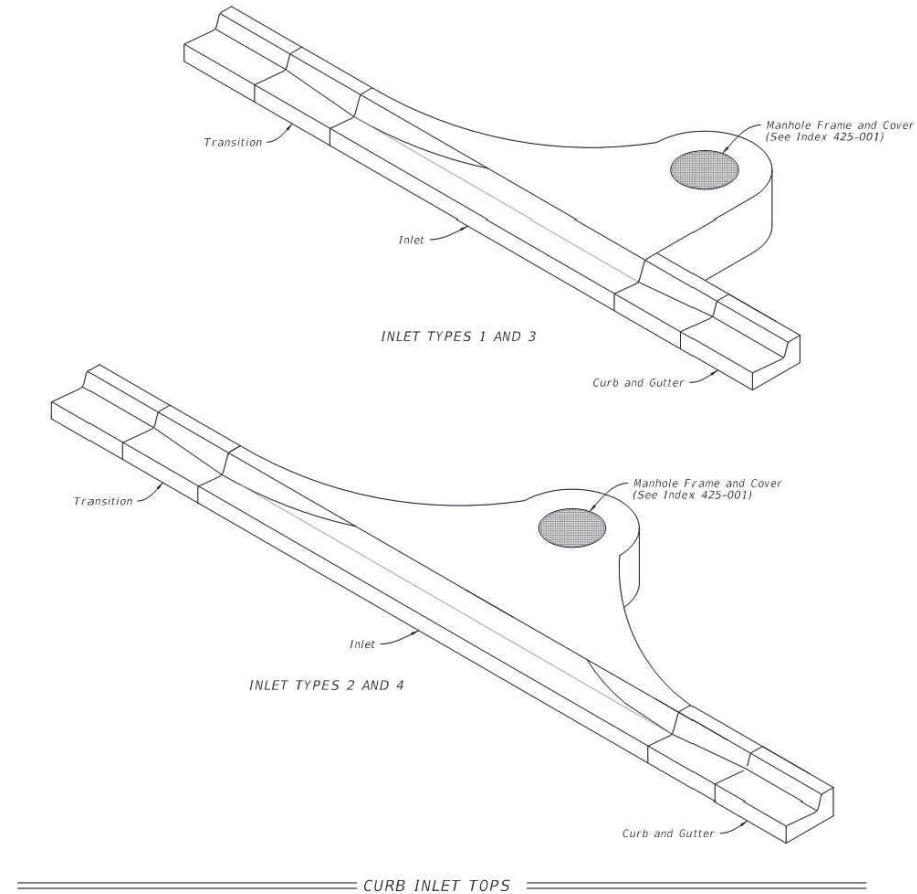

TABLE OF CONTENTS:	
Sheet	Description
1	General Notes and Contents
2	Top Dimensional and Reinforcing Details
3	Transverse Dimensional and Reinforcing Details

10/15/2020 9:28:13 AM

LAST REVISION 11/01/20	DESCRIPTION:	 FY 2021-22 STANDARD PLANS	CURB INLET TOP TYPES 1, 2, 3, AND 4	INDEX 425-020	SHEET 1 of 3
---------------------------	--------------	----------------------------------	-------------------------------------	------------------	-----------------

REVISIONS					
DATE	BY	DESCRIPTION	DATE	BY	DESCRIPTION

DESIGNED BY: A.K.	NAME	DATE	DRAWN BY: J.M.	NAME	DATE
CHECKED BY: L.A.O.			CHECKED BY: L.A.O.		
SUPERVISED BY:					

DEPARTMENT OF TRANSPORTATION
 AND PUBLIC WORKS
 HIGHWAY DIVISION
STEPHEN P. CLARK, CHIEF
 100 N.W. 1ST
 MIAMI, FLORIDA 33138

CURB INLET TOP TYPES 1, 2, 3 AND 4

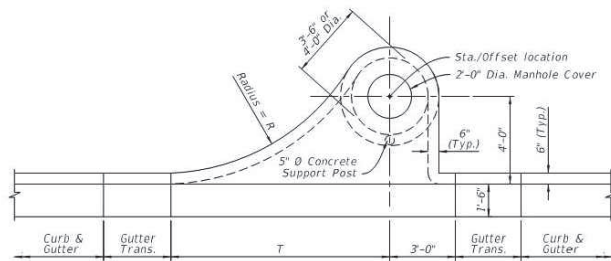

PLAN

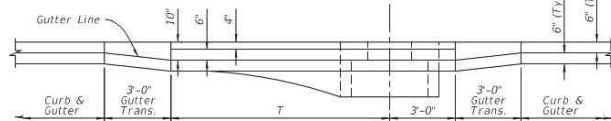

ELEVATION
 TYPE 1 AND 3

TABLE 1
 INLET
 DIMENSIONS

Inlet Type	R	T
1	10'-0"	10'-0"
2	10'-0"	10'-0"
3	6'-0"	6'-0"
4	6'-0"	6'-0"

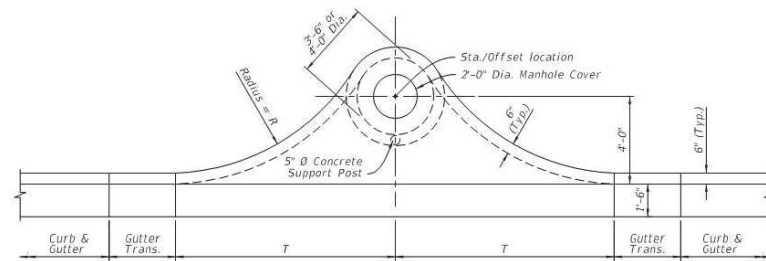

PLAN

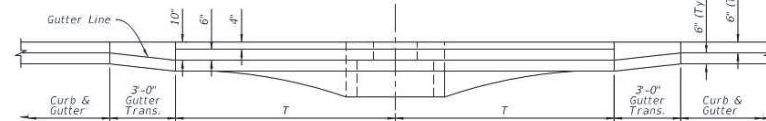

ELEVATION
 TYPE 2 AND 4

TOP DIMENSIONAL DETAILS

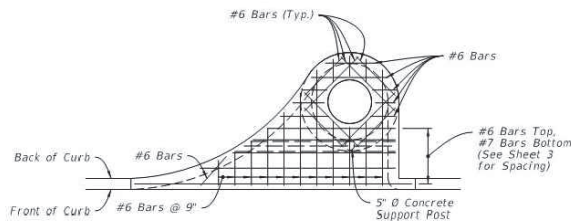

PLAN
 TYPE 1 AND 3

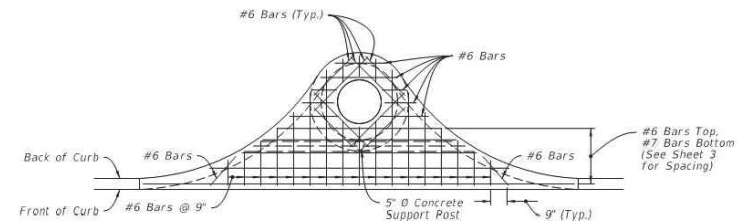

PLAN
 TYPE 2 AND 4

NOTE:
 For transverse section reinforcement, see Sheet 3.

TOP REINFORCING DETAILS

TOP DIMENSIONAL AND TOP REINFORCING DETAILS

LAST REVISION 11/01/20	DESCRIPTION:		FY 2021-22 STANDARD PLANS	CURB INLET TOP TYPES 1, 2, 3, AND 4	INDEX	SHEET
					425-020	2 of 3

REVISIONS					
DATE	BY	DESCRIPTION	DATE	BY	DESCRIPTION

DESIGNED BY	NAME	DATE	DRAWN BY	NAME	DATE
CHECKED BY	L.I.O.		CHECKED BY	L.I.O.	
SUPERVISED BY:					



CURB INLET TOP TYPES 1, 2, 3 AND 4

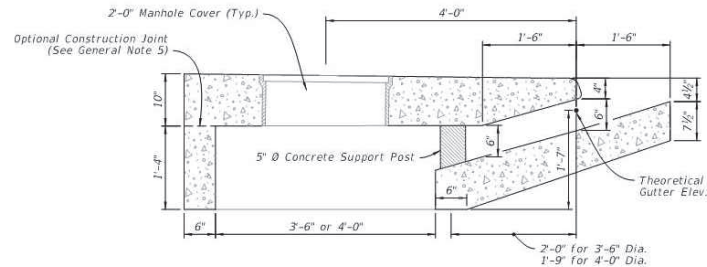

INLET SECTION WITH TYPE F CURB AND GUTTER

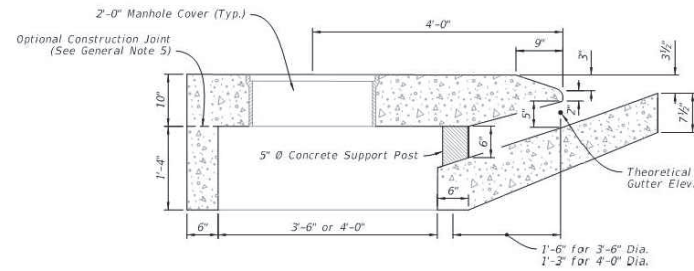

INLET SECTION WITH TYPE E CURB AND GUTTER

TRANSVERSE DIMENSIONAL DETAILS

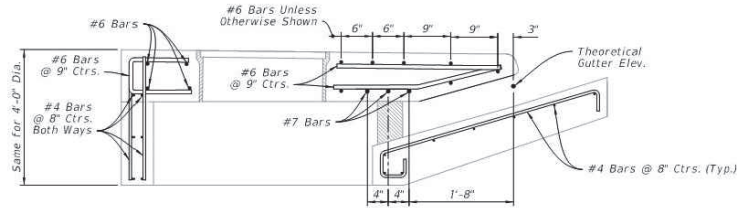

3'-6" DIA. STRUCTURE BOTTOM

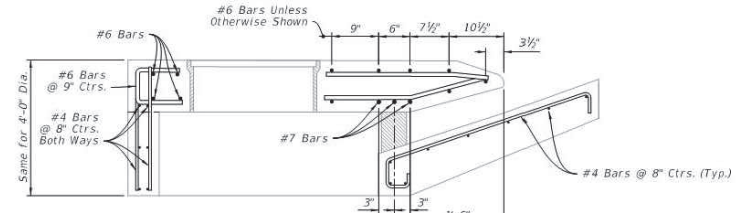

3'-6" DIA. STRUCTURE BOTTOM

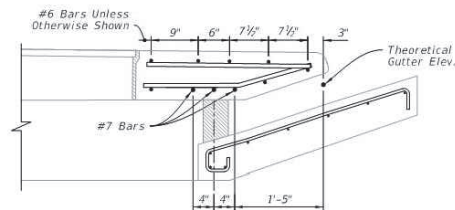

4'-0" DIA. STRUCTURE BOTTOM
 INLET SECTION WITH TYPE F CURB AND GUTTER

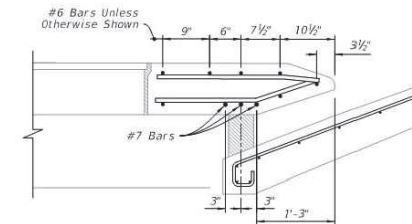

4'-0" DIA. STRUCTURE BOTTOM
 INLET SECTION WITH TYPE E CURB AND GUTTER

TRANSVERSE REINFORCING DETAILS

TRANSVERSE DIMENSIONAL AND REINFORCING DETAILS

LAST REVISION
 11/01/20

DESCRIPTION:

FDOT
 FY 2021-22
 STANDARD PLANS

CURB INLET TOP TYPES 1, 2, 3, AND 4

INDEX
 425-020

SHEET
 3 of 3

P:\My\Planning\Highway\Old Cutler Road - Roundabouts\Plan (CAD & PDF files)\CAD\10-25D-20D-CMS\dwg Feb 14, 2022 - 1:45pm E215983

18/12/2020 6:44:02 AM

REVISIONS					
DATE	BY	DESCRIPTION	DATE	BY	DESCRIPTION

DESIGNED BY	NAME	DATE	DRAWN BY	NAME	DATE
	A.M.			J.M.	
CHECKED BY	L.A.O.		CHECKED BY	L.A.O.	
SUPERVISED BY:					



CURB INLET TOP TYPES 1, 2, 3 AND 4

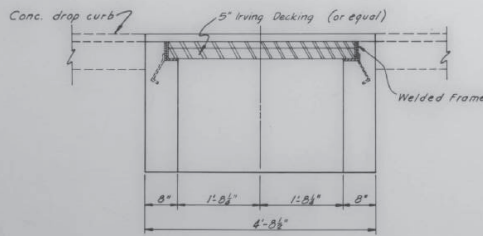
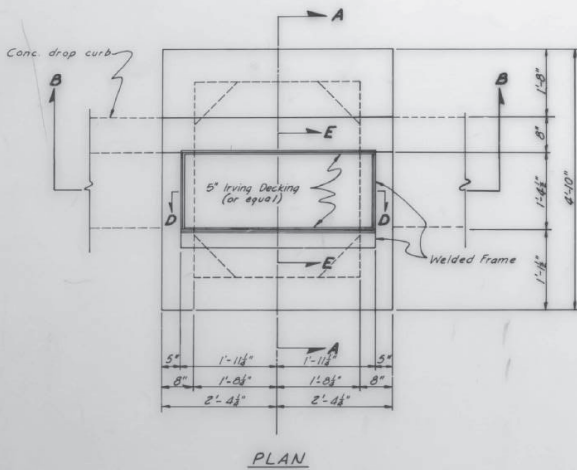

SECTION B-B

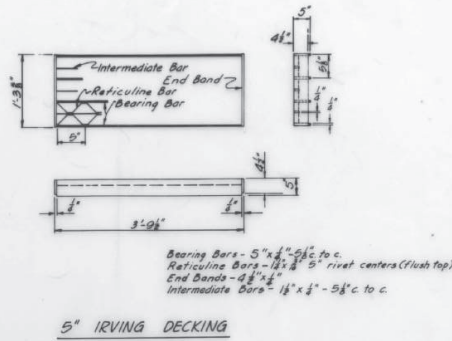

5" IRVING DECKING

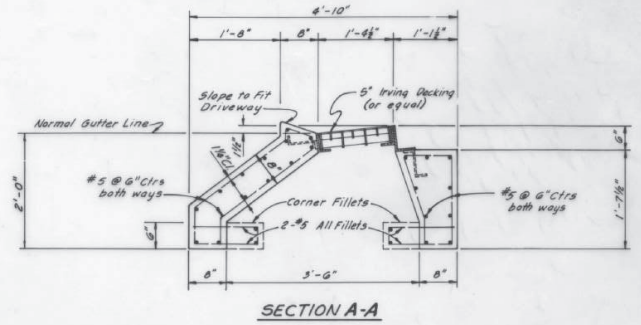

SECTION A-A

GENERAL NOTES:
 1. This type inlet top to be used whenever proposed inlet falls within driveway location.
 2. When inlets are to be constructed on a curve, refer to the plans to determine the radius and, where necessary, modify the inlet details accordingly. Bend steel when necessary.
 3. The corner fillets are necessary only when tops are used in conjunction with circular inlet boxes or when used on skew with rectangular inlet boxes.

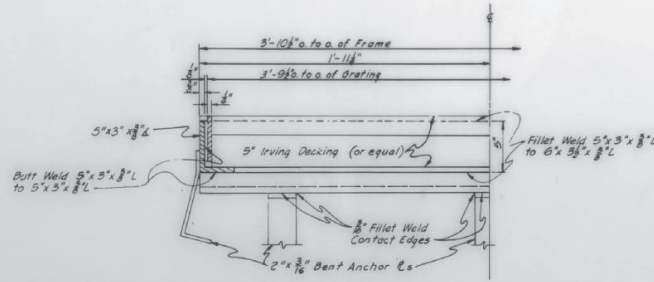

HALF SECTION D-D

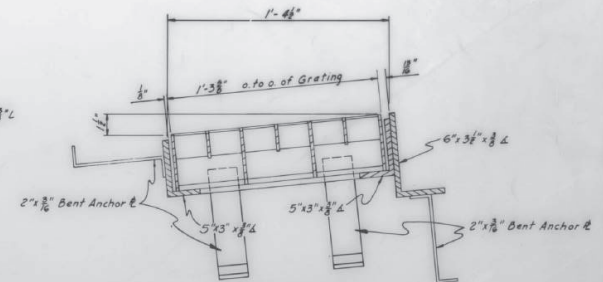

SECTION E-E

DETAILS OF FRAME AND 5" IRVING DECKING

DETAILS OF INLET TOP TYPE 11

Any grating that is capable of supporting H-20 loads may be substituted for the 5" Irving Decking at the option of the Contractor, providing it meets the following two conditions:
 1. The net open area of the grate must not be less than that of the Irving
 2. The maximum distance (measured perpendicular) between bars does not exceed 3".

P:\My\Projects\Highway\Old Cutler Road - Roundabouts\Plan (CAD & PDF files)\CAD\10-20-22\10-20-22\10-20-22.dwg Feb 14, 2022 1:45pm 2/15/2023

DADE COUNTY PUBLIC WORKS DEPARTMENT
 HIGHWAY DIVISION
 DIVISION
 P.E.K.-R.Y. INLET TOP TYPE 11
 DRAWN
 CHECKED
 PROPOSED
 5-F
 QUANTIFIED
 RECOMMENDED
 DATE 10-8-71

REVISIONS					
DATE	BY	DESCRIPTION	DATE	BY	DESCRIPTION

DESIGNED BY	NAME	DATE	DRAWN BY	NAME	DATE
	A.K.		J.M.		
	L.A.O.		L.A.O.		

DEPARTMENT OF TRANSPORTATION AND PUBLIC WORKS
 HIGHWAY DIVISION
 MIAMI-DADE COUNTY

INLET TOP TYPE 11

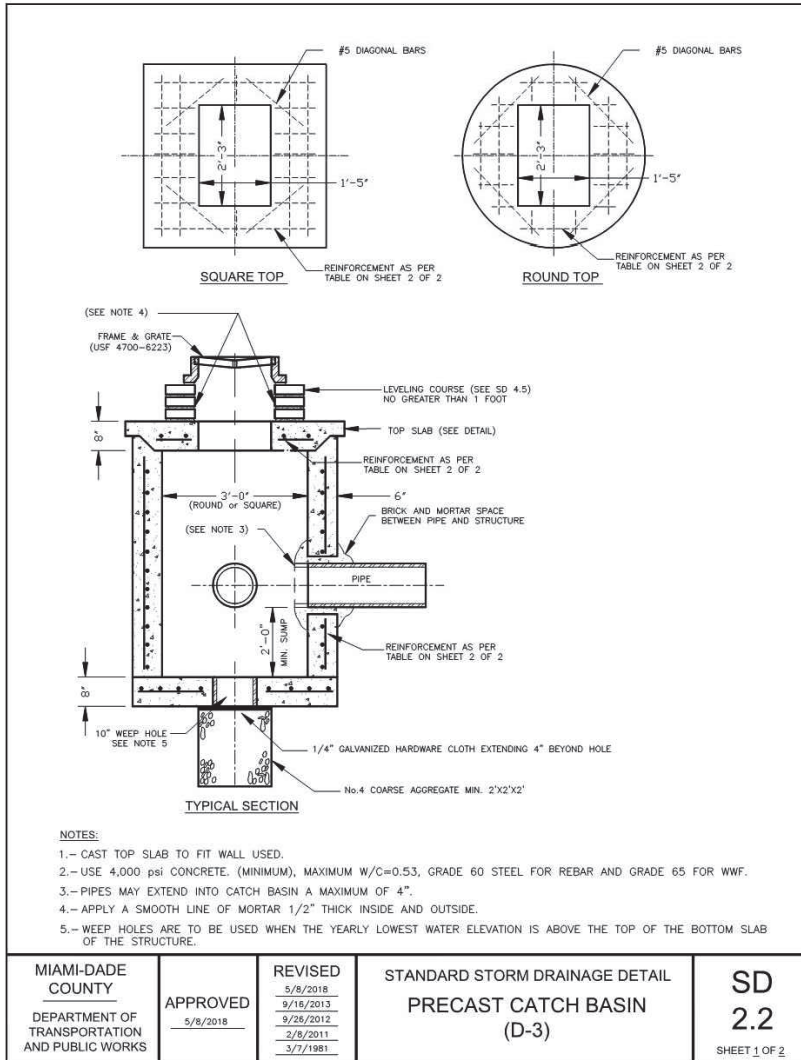

SQUARE STRUCTURE									
Standard Detail	Width (ft)	Length (ft)	Height (ft)	Wall Thickness (in)	Wall Steel	Top Slab Thickness (in)	Top Slab Steel	Bottom Slab Thickness (in)	Bottom Slab Steel
2.2	3	3	0.0 - 5.0	6	#4@10"H #4@10"V	8	#4@5" E.W.	8	#4@10" E.W.
2.2	3	3	5.1 - 10.0	6	#4@7.5"H #4@10"V	8	#4@5" E.W.	8	#4@10" E.W.
2.2	3	3	10.1-15.0	6	#5@7.5"H #4@10"V	8	#4@5" E.W.	8	#4@10" E.W.

ROUND STRUCTURE									
Standard Detail	Dia. (ft)	Height (ft)	Wall Thickness (in)	Wall Steel	Top Slab Thickness (in)	Top Slab Steel	Bottom Slab Thickness (in)	Bottom Slab Steel	
2.2	3	0.0 - 5.0	6	8 X 8 W20 #4@10"E.W.	8	#4@5" E.W.	8	#4@10" E.W.	
2.2	3	5.1 - 15.0	6	8 X 8 W20 #4@10"E.W.	8	#4@5" E.W.	8	#4@10" E.W.	

MIAMI-DADE COUNTY DEPARTMENT OF TRANSPORTATION AND PUBLIC WORKS	APPROVED 5/8/2018	REVISED 5/8/2018	STANDARD STORM DRAINAGE DETAIL PRECAST CATH BASIN (TYPE D-3)	SD 2.2 SHEET 2 OF 2
--	----------------------	---------------------	--	---------------------------

P:\My\Planning\Highway\Old Cutler Road - Roundabout\Draw (CAD & PDF files)\CD\10-3D-MSD-CMS.dwg Feb 14, 2022 1:46pm 2/15/2023

REVISIONS					
DATE	BY	DESCRIPTION	DATE	BY	DESCRIPTION

DESIGNED BY: A.K.	NAME: A.K.	DATE: 5/8/2018	DRAWN BY: J.M.	NAME: J.M.	DATE: 5/8/2018
CHECKED BY: L.A.O.	NAME: L.A.O.	DATE: 5/8/2018	CHECKED BY: L.A.O.	NAME: L.A.O.	DATE: 5/8/2018
SUPERVISED BY: MIAMI-DADE COUNTY					

DEPARTMENT OF TRANSPORTATION AND PUBLIC WORKS
HIGHWAY DIVISION
STEPHEN P. CLAY CENTER
1000 N.W. 111
MIAMI, FLORIDA 33128

PRECAST CATCH BASIN (D-3)

NOTES:

1. Shop Drawings are required.
2. Work with Specification 515.
3. Materials:
 - A. Pan Head Set Screws: Aluminum Alloy 2024-T4 or 7075-T73 or Stainless Steel (SS) Type 316 or 18-8 Alloy.
 - B. Base Plates and Cap Plates: ASTM B209, Alloy 6061-T6
 - C. Structural Pipe Tube and Bars: ASTM B221 or ASTM B429, Alloy 6061-T6
 - D. End Rails 90° bends and corner bends with a maximum 4 foot spacing: Alloy 6063-T5 is permitted.

RAILING MEMBER DIMENSIONS TABLE			
MEMBER	DESIGNATION	OUTSIDE DIMENSION	WALL THICKNESS
Posts	2" NPS (Sch. 40)	2.375"	0.154"
Rails	2" NPS (Sch. 40)	2.375"	0.154"
Rail Joint/Splice Sleeves	1½" NPS (Sch. 40)	1.900"	0.145"
Handrails Joint/Splice Sleeves	1" NPS (Sch. 40) 1.50 ODx0.125 Wall	1.315" 1.500"	0.133" 0.125"
Handrails	1½" NPS (Sch. 40)	1.900"	0.145"
Handrail Support Bar	1" Ø Round Bar	1.000"	N/A

- E. Galvanized Steel Fasteners:
 - a. Hex Head Bolts: ASTM A 307 Type 1 or ASTM F1554 Grade 36
 - b. Adhesive Anchors: ASTM F1554 Grade 36 fully threaded rods
 - c. Hex Nuts: ASTM A563
 - d. Flat Washers: ASTM F436
- F. Aluminum Shims: ASTM B209, Alloy 6061
- G. Bearing Pads: Plain, Fabric Reinforced, or Fabric Laminated meeting requirements of Specifications 515 & 932.
4. Fabrication:
 - A. Place expansion joints at a maximum of 30'-0" spacing
 - B. Field splices are similar to the expansion joint detail and may be approved by the Engineer to facilitate handling; but top rail must be continuous across a minimum of two posts.
 - C. Continuity field splice (Detail "E"); only use to make the railing continuous for unforeseen field adjustments
 - D. Corners and changes in tangential longitudinal alignment may be made continuous with a 9" bend radius or terminated at adjoining sections with a standard end hoop when handrails are not required.
 - E. For curved longitudinal alignments, shop bend top and bottom rails and handrails to match the alignment radius.
 - F. For changes in tangential longitudinal alignment greater than 45°, position posts a maximum of 2'-0" each side of the corner, not at the corner apex.
5. Handrails are required and must be continuous at landings for:
 - A. Grades Steeper than 5%
 - B. Three or more steps
6. Cutting of reinforcing steel is permitted for post installed anchor bolts.

18/11/22/2025 7:39:51 AM

LAST REVISION 11/01/18	DESCRIPTION:	 FY 2021-22 STANDARD PLANS	PIPE GUIDERAIL (ALUMINIUM)	INDEX 515-070	SHEET 1 of 5
---------------------------	--------------	--	-----------------------------------	-------------------------	------------------------

REVISIONS					
DATE	BY	DESCRIPTION	DATE	BY	DESCRIPTION

DESIGNED BY: A.K.	NAME: A.K.	DATE:	DRAWN BY: J.M.	NAME: J.M.	DATE:
CHECKED BY:	L.A.O.		CHECKED BY:	L.A.O.	
SUPERVISED BY:					

MIAMI-DADE COUNTY

**DEPARTMENT OF TRANSPORTATION AND PUBLIC WORKS
HIGHWAY DIVISION**

STEPHEN P. CLARK, CENTER
100 N.W. 11th ST.
MIAMI, FLORIDA 33138

PIPE GUIDERAIL (ALUMINIUM)

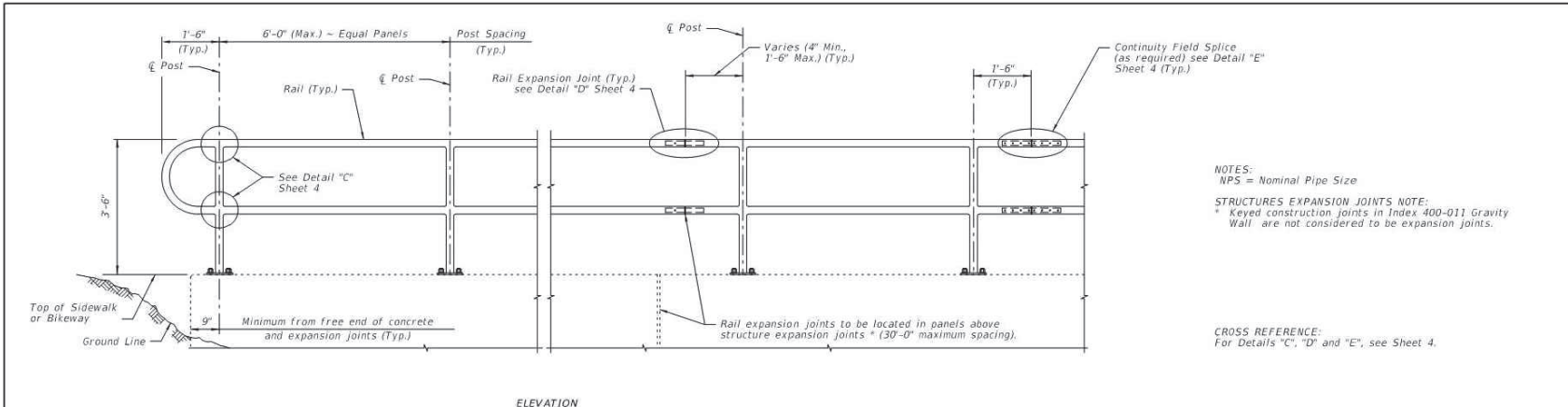

NOTES:
 NPS = Nominal Pipe Size
 STRUCTURES EXPANSION JOINTS NOTE:
 * Keyed construction joints in Index 400-011 Gravity Wall are not considered to be expansion joints.

CROSS REFERENCE:
 For Details "C", "D" and "E", see Sheet 4.

TYPICAL RAILING DETAILS & RAILINGS ON GRADES 0% TO 5%

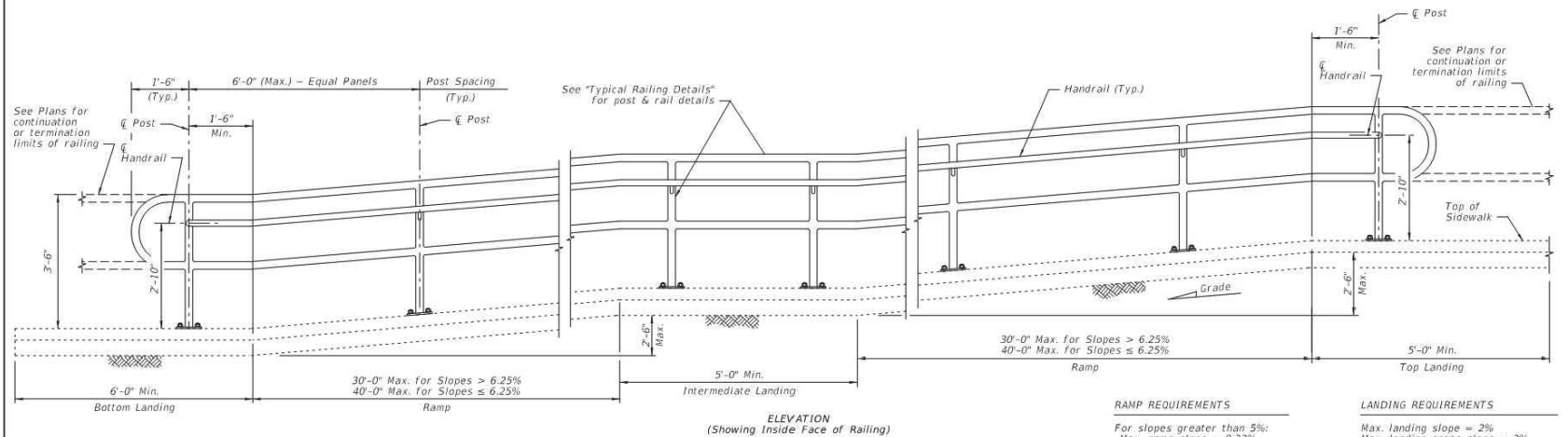

RAMP REQUIREMENTS
 For slopes greater than 5%:
 Max. ramp slope = 8.33%
 Max. ramp cross-slope = 2.0%

LANDING REQUIREMENTS
 Max. landing slope = 2%
 Max. landing cross-slope = 2%

RAILINGS ON GRADES STEEPER THAN 5% TO 8.33%

LAST REVISION 11/01/17	DESCRIPTION:	FDOT	FY 2021-22 STANDARD PLANS	PIPE GUIDERAIL (ALUMINIUM)	INDEX 515-070	SHEET 2 of 5
---------------------------	--------------	------	------------------------------	----------------------------	------------------	-----------------

REVISIONS					
DATE	BY	DESCRIPTION	DATE	BY	DESCRIPTION

DESIGNED BY	NAME	DATE	DRAWN BY	NAME	DATE
	A.K.			J.M.	
CHECKED BY	L.A.O.		CHECKED BY	L.A.O.	
SUPERVISED BY:					

MIAMI-DADE COUNTY
 DEPARTMENT OF TRANSPORTATION AND PUBLIC WORKS
 HIGHWAY DIVISION
 STEPHEN P. CLAY CENTER
 100 N.W. 11th St.
 MIAMI, FLORIDA 33138

PIPE GUIDERAIL (ALUMINIUM)

P:\my\p\miami\highway\Old Cutler Road - Roundabouts\Plan (CAD & PDF files)\CD110-35D-801-CMS\dwg Feb 14, 2022 - 1:46pm 12/19/23

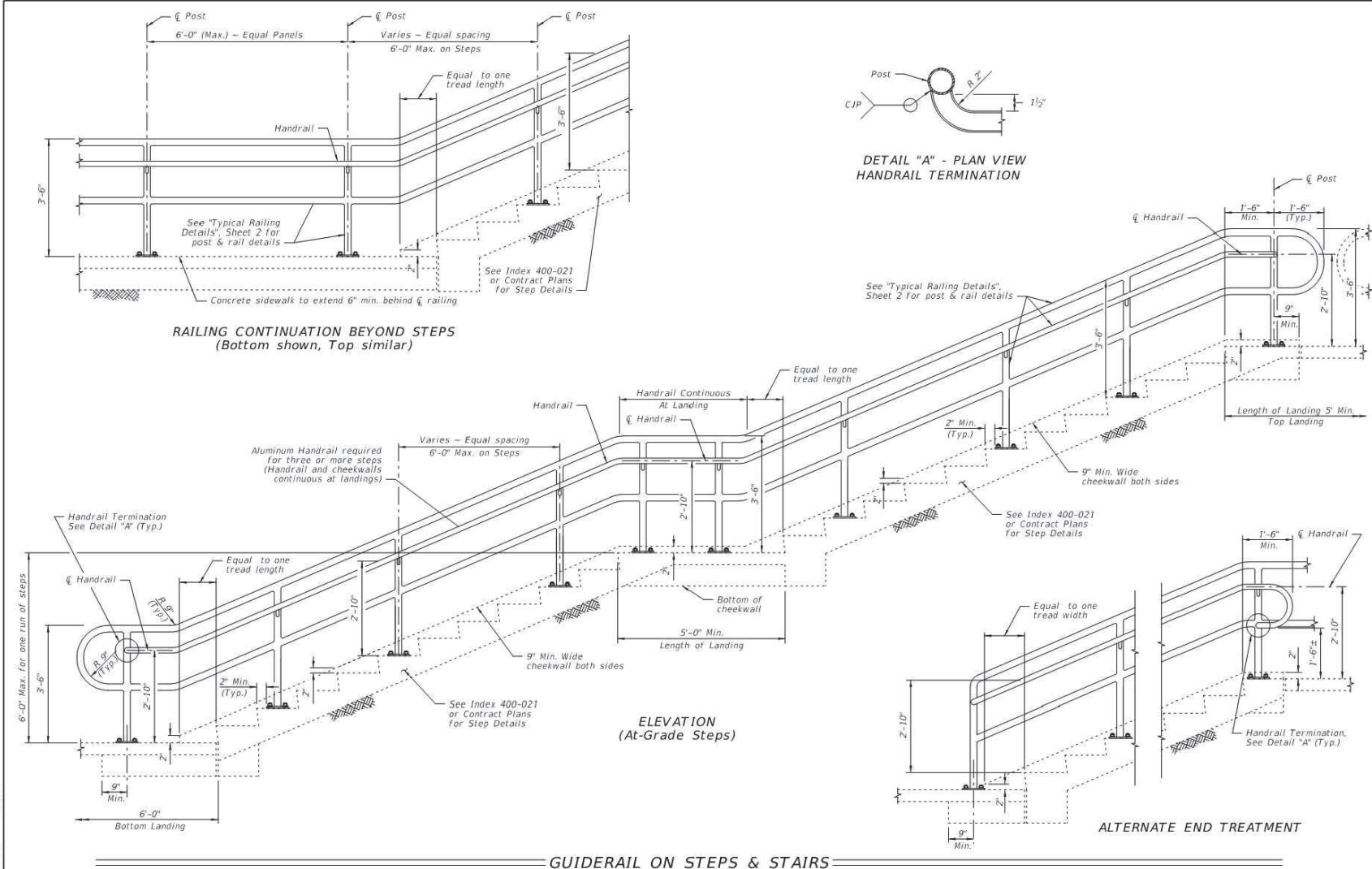

LAST REVISION 11/01/17	DESCRIPTION:	FDOT	FY 2021-22 STANDARD PLANS	PIPE GUIDERAIL (ALUMINIUM)	INDEX 515-070	SHEET 3 of 5
---------------------------	--------------	------	------------------------------	----------------------------	------------------	-----------------

REVISIONS					
DATE	BY	DESCRIPTION	DATE	BY	DESCRIPTION

DESIGNED BY: A.M.	NAME: A.M.	DATE:	DRAWN BY: J.M.	NAME: J.M.	DATE:
CHECKED BY: L.A.O.	NAME: L.A.O.	DATE:	CHECKED BY: L.A.O.	NAME: L.A.O.	DATE:
SUPERVISED BY:					

MIAMI-DADE COUNTY
 DEPARTMENT OF TRANSPORTATION AND PUBLIC WORKS
 HIGHWAY DIVISION
 STEPHEN P. CLAY CENTER
 100 W. W. 11
 MIAMI, FLORIDA 33138

PIPE GUIDERAIL (ALUMINIUM)

P:\my\p\miami\highway\old cutler road - Roundabouts\Plan (CAD & PDF files)\21-01-21D-021-021-021.dwg Feb 14, 2022 3:39:55 AM 2/15/2022

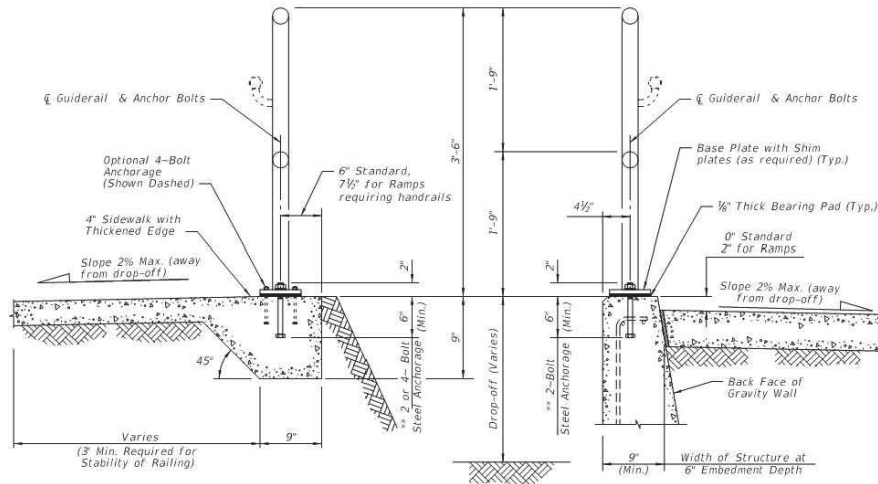

TYPICAL SECTION ON CONCRETE SIDEWALK

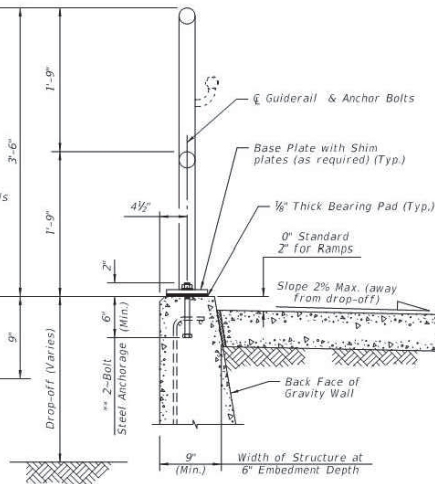

TYPICAL SECTION ON GRAVITY WALL
(Other Retaining Walls Similar)

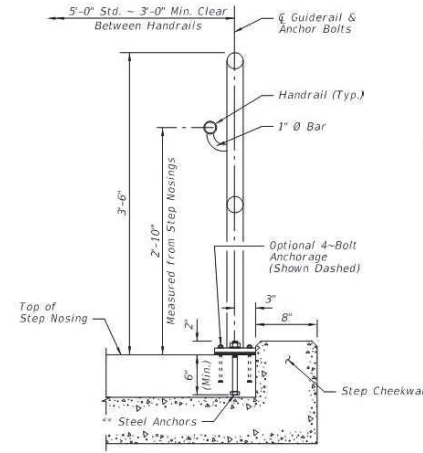

TYPICAL SECTION ON STEPS & STAIRS

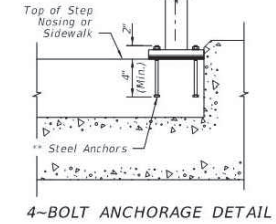

4-BOLT ANCHORAGE DETAIL

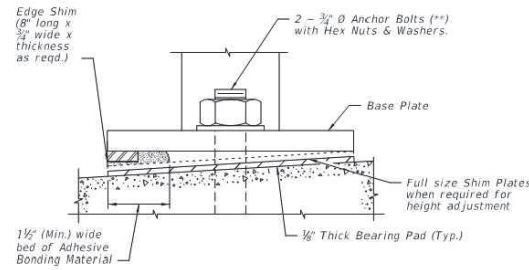

DETAIL "F" (OPTIONAL SHIMMING DETAIL FOR CROSS SLOPE CORRECTION)
(Used in lieu of Beveled Shim Plates)

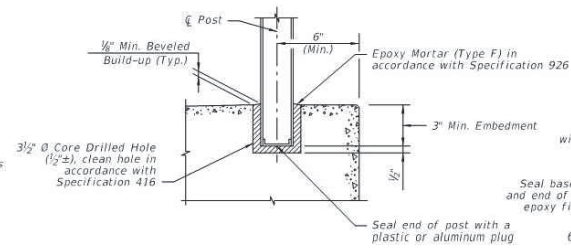

SIDEWALK ANCHORAGE DETAIL OPTION 1

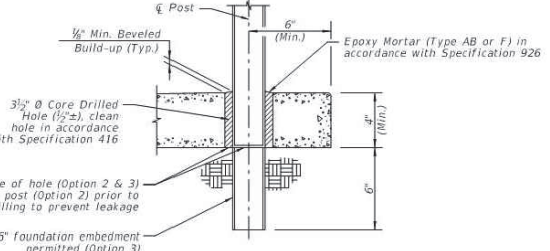

SIDEWALK ANCHORAGE DETAIL OPTION 2 & 3

NOTES:
 *** 2 - 3/8" Ø x 8" or 4 - 7/8" Ø x 6" Steel Anchors; Galvanized Steel Bolts (As Shown) (C-1-P); Galvanized U-Bolts Permitted (C-1-P); Galvanized Adhesive Anchors Permitted
 *** The minimum embedment for Adhesive Anchors is 6" for 2-Bolt Anchorage or 4" for 4-Bolt Anchorage.

LAST REVISION	DESCRIPTION:
11/01/20	

FDOT
 FY 2021-22
 STANDARD PLANS

PIPE GUIDERRAIL (ALUMINIUM)

INDEX SHEET
 515-070 5 of 5

REVISIONS					
DATE	BY	DESCRIPTION	DATE	BY	DESCRIPTION

DESIGNED BY	NAME	DATE	DRAWN BY	NAME	DATE
	A.K.			J.M.	
	L.A.O.			L.A.O.	

DEPARTMENT OF TRANSPORTATION AND PUBLIC WORKS
 HIGHWAY DIVISION
 MIAMI-DADE COUNTY
 ENGINEER
 SUPERVISOR

PIPE GUIDERRAIL (ALUMINIUM)

P:\Miami\Highway\Old Cutler Road - Roundabouts\Plan (CAD & PDF files)\CD-10-25D-2021-0801-DMS.dwg Feb 14, 2022 - 1:46pm E2119683

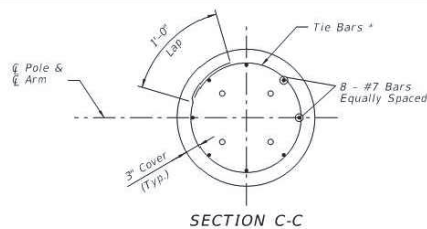

SECTION C-C

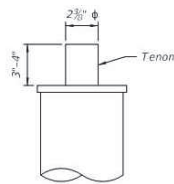

TOP MOUNT TENON

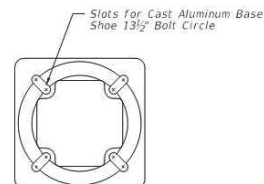

TOP VIEW TRANSFORMER BASE

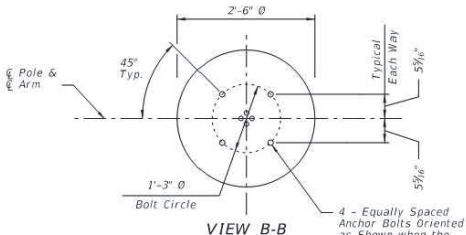

VIEW B-B

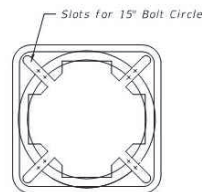

BOTTOM VIEW TRANSFORMER BASE

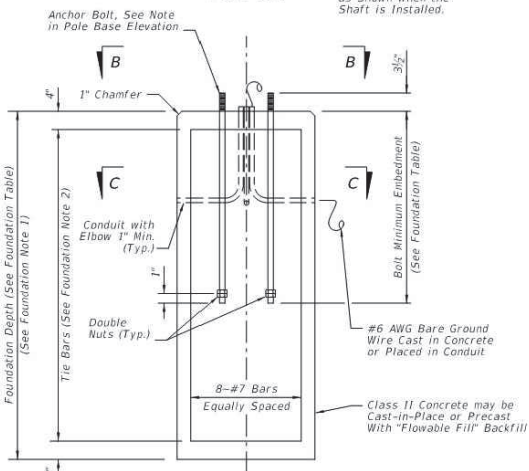

FOUNDATION NOTES:

1. Depths shown are for slopes equal to or flatter than 1:4. For slopes steeper than 1:4 and equal to or flatter than 1:2 add 2'-6" to foundation depths shown.
2. Foundation Tie Bars: #4 Tie Bars @ 12" centers (max.) or D10 (or W10) spiral @ 6" pitch, 3 flat turns top and 1 flat turn bottom.

FOUNDATION

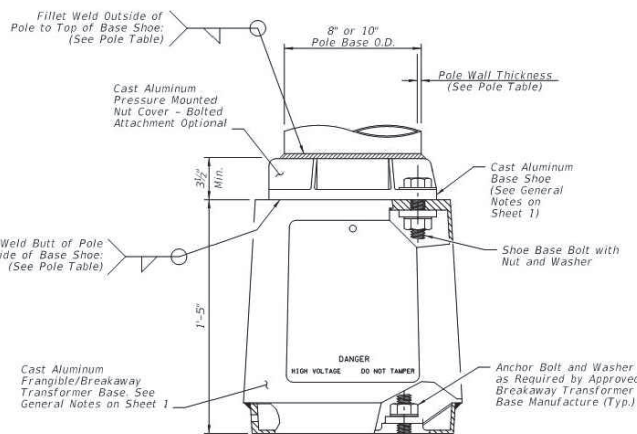

POLE BASE ELEVATION

ARM-POLE TABLE						
FOR STANDARD ALUMINUM LIGHT POLES WITH ARM						
Assembly Height (ft)	Wind Speed and Arm Lengths (ft)					
	120 mph		140 mph		160 mph	
	8, 10, 12, 15	8, 10, 12	15	8, 10	12, 15	
30						
35	A1-P1	A1-P1	A2-P1	A1-P1	A2-P1	
40				A1-P2	A2-P2	
45	A1-P2	A1-P2	A2-P2			
50				A1-P3	A2-P3	

ARM POLE NOTES:

1. See ARM SECTION detail on Sheet 3 for all A1 and A2 Values.
2. See Pole Table for all P1, P2, and P3 values.
3. For Median Barrier Mounted Pole, Use Arm A1.
4. For 20' and 25' assembly heights use only 8' or 10' arm A1 with P0.

POLE TABLE			
Pole	Pole Wall Thickness	Top of Base Shoe Weld	Inside of Base Shoe Weld
P0	0.156	3/16"	3/16"
P1	0.156	3/16"	3/16"
P2	0.250	1/2"	1/2"
P3	0.313	3/8"	3/8"

POLE NOTES:

1. Pole wall thicknesses shown are nominal and must be within the Aluminum Association tolerances.
2. Thicker walls are permitted and tapered walls may be used in accordance with the minimum Aluminum Association thicknesses.

TOP MOUNT POLE TABLE				
FOR STANDARD ALUMINUM LIGHT POLES WITH TOP MOUNT				
Assembly Height (ft)	Wind Speed and Arm Lengths (ft)			
	120 mph	140 mph	160 mph	
20			Pole P0	
25	Pole P0	Pole P0	Pole P0	
30			Pole P1	
35	Pole P1	Pole P1	Pole P1	
40			Pole P2	
45	Pole P2	Pole P2	Pole P2	
50			Pole P2	

FOUNDATION TABLE				
Pole	P0	P1	P2	P3
Depth	6'-0"	7'-0"	8'-0"	8'-0"
Bolt Min. Embedment	2'-6"	3'-6"	3'-6"	3'-6"

POLE AND BASE DETAILS FOR ROADWAY ALUMINUM LIGHT POLE

STANDARD ALUMINUM LIGHTING

INDEX SHEET
715-002 4 of 8

LAST REVISION	DESCRIPTION:
11/01/21	

FDOT
FY 2022-23
STANDARD PLANS

REVISIONS					
DATE	BY	DESCRIPTION	DATE	BY	DESCRIPTION

DESIGNED BY	NAME	DATE	DRAWN BY	NAME	DATE
	A.K.			J.M.	
	L.A.O.			L.A.O.	

DEPARTMENT OF TRANSPORTATION AND PUBLIC WORKS
HIGHWAY DIVISION
MIAMI-DADE COUNTY
SMYRNA S. CLAY CENTER
MIAMI, FLORIDA 33138

PIPE GUIDERAIL (ALUMINUM)