

SW 57 AV SW 72 ST INTERSECTION IMPROVEMENTS

FDOT PROJECT FM 449752-1-58-01
 MIAMI DADE COUNTY PROJECT 20210187

SHEET No.	DESCRIPTION
1.	KEY SHEET
2.	SIGNATURE SHEET
3.	SUMMARY OF QUANTITIES
4.	ROADWAY PLAN
5.	RAMP DETAILS
6.	SIGNING AND PAVEMENT MARKING PLAN
7.	TRAFFIC SIGNAL PLAN (ASSET# 3303)
8. to 11.	TEMPORARY TRAFFIC CONTROL PLANS

STANDARD INDEX DRAWINGS

- M.D.C SECTION 639: ELECTRICAL POWER SERVICE ASSEMBLY.
- M.D.C SECTION 660: VEHICLE DETECTION SYSTEM.
- M.D.C SECTION 671: TRAFFIC SIGNAL CONTROLLERS.
- M.D.C SECTION 630: CONDUIT.
- M.D.C SECTION 635: PULL, SPLICE, AND JUNCTION BOXES.
- MIAMI DADE COUNTY, INLET PROTECTION SYSTEMS DETAILS.
- FDOT TREE PROTECTION INDEX 110-100

GOVERNING STANDARD PLANS:

FLORIDA DEPARTMENT OF TRANSPORTATION, FY 2023-23 STANDARD PLANS FOR ROAD AND BRIDGE CONSTRUCTION AND APPLICABLE INTERIM REVISIONS IRs. STANDARD PLANS FOR ROAD CONSTRUCTION AND ASSOCIATED IRs ARE AVAILABLE AT THE FOLLOWING WEBSITE: <http://www.fdot.gov/design/standardplans>

GOVERNING STANDARD SPECIFICATIONS:

MIAMI DADE COUNTY PUBLIC WORKS DEPARTMENT STANDARDS SPECIFICATIONS PARTS 1, 2, & 3. FLORIDA DEPARTMENT OF TRANSPORTATION, FISCAL YEAR 2023 STANDARD SPECIFICATIONS FOR ROAD AND BRIDGE CONSTRUCTION AT THE FOLLOWING WEBSITE: <http://www.fdot.gov/design/standardplans/current/default.shm>

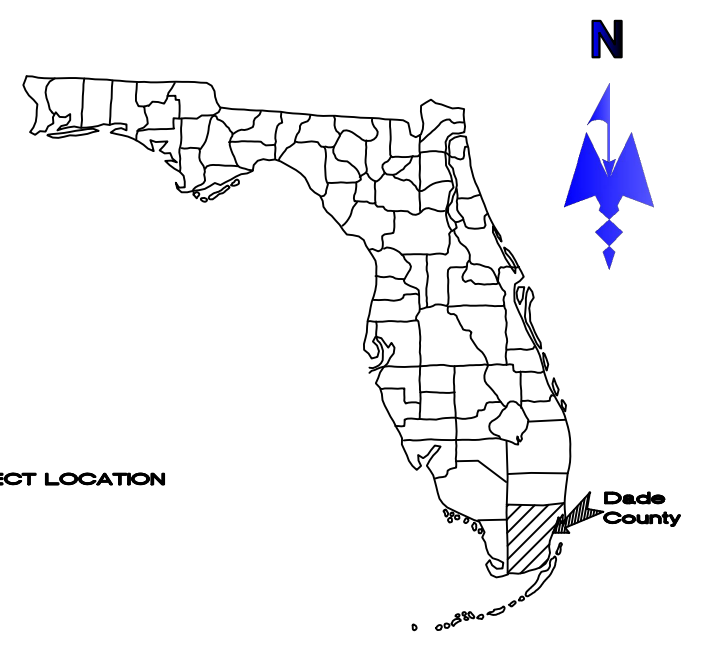
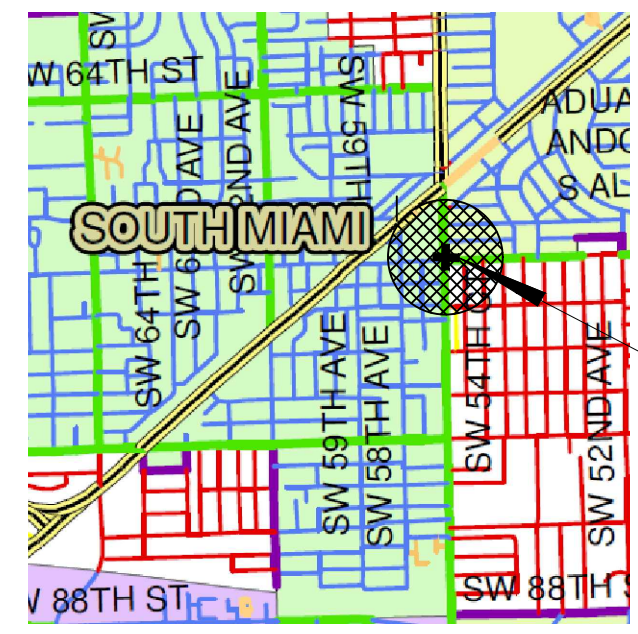

PROJECT LOCATION

MIAMI DADE COUNTY PROJECT MANAGER:
 WILLIAM SALAZAR, TRAFFIC ENGINEER 3

MIAMI DADE COUNTY PROJECT ENGINEER OF RECORD:
 YANEK FERNANDEZ, PE, ENGINEER 4 - HIGHWAY DIVISION

NOTE:
 ATTENTION IS DIRECTED TO THE FACT THAT THESE PLANS MAY HAVE BEEN REDUCED IN SIZE BY REPRODUCTION. THIS MUST BE CONSIDERED WHEN OBTAINING SCALED DATA.

REVISIONS

DATE	BY	DESCRIPTION	DATE	BY	DESCRIPTION

MIAMI-DADE COUNTY
 HIGHWAY DIVISION

DESIGNED BY	NAME	DATE	DRAWN BY	NAME	DATE
	W.Z	10/06/22		L.J.D	11/21/2022

CHECKED BY: YANEK FERNANDEZ, P.E.



SW 57 AV & SW 72 ST
 (KEY SHEET)
 ASSET#: 3303

THE OFFICIAL RECORD OF THIS SHEET IS THE ELECTRONIC FILE DIGITALLY SIGNED AND SEALED UNDER RULE 6105-23.001(2)(b)-FPBE

THIS ITEM HAS BEEN SIGNED AND SEAL BY

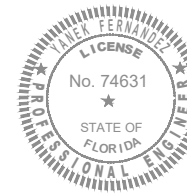

ON THE DATE ADJACENT TO THE SEALED

PRINTED COPIES OF THIS DOCUMENT ARE
 NOT CONSIDERED SIGNED AND SEALED
 AND THE SIGNATURE MUST BE VERIFIED
 ON THE ELECTRONIC COPIES

MIAMI-DADE COUNTY
 111 NW 1 STREET
 SUITE 1510
 MIAMI, FL 33128

REVISIONS					
DATE	BY	DESCRIPTION	DATE	BY	DESCRIPTION

MIAMI-DADE COUNTY
 HIGHWAY DIVISION

	NAME	DATE	NAME	DATE
DESIGNED BY	W.Z	10/06/22	DRAWN BY	L.J.D
CHECKED BY			CHECKED BY	
SUPERVISED BY:				

MIAMI-DADE COUNTY



DEPARTMENT OF TRANSPORTATION
 AND PUBLIC WORKS
 HIGHWAY DIVISION
 STEPHEN P. CLARK CENTER
 111 NW 1 ST
 MIAMI, FLORIDA 33128

**PROJECT SUMMARY OF PAY ITEMS
 FOR PROJECT: SCRAMBLE INTERSECTION AT SW 57AV / SW 72 ST**

ITEM NO.	DESCRIPTION	UNIT	Qty.
104 -18	Inlet protection System	EA	3
580-3	TREE PROTECTION BARRIER	L.F.	100
1104-2H	REMOVAL AND DISPOSAL OF EXISTING CONCRETE SIDEWALK (up to 8" thick)	S.Y.	150
1104-10C	REMOVE AND DISPOSE EXISTING CURB & GUTTER	L.F.	300
351-1A	COLOR CONCRETE CURB AND GUTTER (Type F)	L.F.	80
351-1C	COLORED CONCRETE SIDEWALK (6" Thick)	S.Y.	80
520-2	CONCRETE CURB AND GUTTER (Any type, Including base preparation)	L.F.	300
522-2(1)	CONCRETE SIDEWALK 6" THICK (Includes driveways)	S.Y.	80
527-2	DETECTABLE WARNING ON WALKING SURFACE	S.F.	88
620-1-1	GROUNDING ELECTRODE	L.F.	140
630-2-11	Conduit, F&I, Open Trench	L.F.	100
630-2-12	Conduit, F&I, Directional Bore	L.F.	1200
632-7-6	SIGNAL CABLE, REMOVE INTERSECTION	P.I.	1
632-7-1A	TRAFFIC CONTROL CABLE - (11-21 conductor)	L.F.	800
632-7-1B	TRAFFIC CONTROL CABLE - (4 -7 conductor)	L.F.	500
635-2-11	Pull & Splice Box, F&I, 13" X 24" Cover Size	EA	15
635-2-15A	PULL & JUCTION BOXES (F&I) (Fiber Optic)	EA	1
639-1-121	ELECTRICAL POWER SERVICES, Furnish & Install, Underground, meter furnished by Company.	EA	1
639-2-1	SERVICE WIRE (#6 AWG WITH THW INSULATION)(THREE CONDUCTOR SET)(BLACK, WHITE AND GREEN)	L.F.	180
639-3-11	ELECTRICAL SERVICES DISCONNECT, Furnish & Install, Pole Mount.	AS.	1
641-2-12	Pre - stressed Concrete Poles (Furnish and Install) (Type P-II Service Pole)	EA	1
646-1-11	ALUMINUM SIGNALS POLE, (Furnish & Install) (Pedestal)	EA.	3
653-191	PEDESTRIAN SIGNAL, 1Way (LED- Countdown)	AS.	2
653-1-192	Pedestrian Signal (F & I) (LED- Countdown) (Two Ways)	AS.	2
660-1-109C	INDUCTIVE LOOP DETECTOR F&I	AS.	7
660-2-106	LOOP ASSEMBLY, F&I, Type F	AS.	4
660-4-4A	LOOP LEAD IN CABLE (No. 14 A.W.G.)	L.F.	180
665-11	PEDESTRIAN DETECTOR (Includes Push Button Sign R10-3B)	EA.	4
672-1-3	INSTALL TRAFFIC CONTROLLER ASSEMBLY (Build-up controller & components furnished by County. Contractor to construct foundation, install and wire controller & components for a complete installation)	AS.	1
690-20	REMOVE PEDESTRIAN SIGNAL HEAD ASSEMBLY	EA	2
690-50	REMOVE CONTROLLER ASSEMBLY	EA.	1
690-51	REMOVE CONTROLLER FOUNDATION Includes proper disposal, and grading of area if required.	EA.	1
690 -70A	REMOVE PEDESTRIAN DETECTOR ASSEMBLY (Includes Push Button Sign)	EA.	1
690 -101	REMOVE EXISTING POWER SERVICE (Includes complete removal of riser, disconnect switch box, meter box and ground restoration)	AS.	1
690 - 200	PULL BOX REMOVAL	EA.	6
711 -14-123	THERMOPLASTIC, PREFORMED, WHITE, SOLID, 12" FOR CROSSWALK	L.F.	460
711 -14-125	THERMOPLASTIC, PREFORMED, WHITE, SOLID, 24" FOR CROSSWALK	L.F.	260
711 -17	Removal of existing thermoplastic pavement markings	S.F.	50

REVISIONS					
DATE	BY	DESCRIPTION	DATE	BY	DESCRIPTION

MIAMI-DADE COUNTY
HIGHWAY DIVISION

DESIGNED BY	NAME	DATE	DRAWN BY	NAME	DATE
	W.Z	10/06/22		L.J.D	11/21/2022
CHECKED BY			CHECKED BY		
SUPERVISED BY: YANEK FERNANDEZ, P.E.					

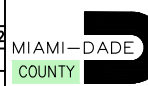
 DEPARTMENT OF TRANSPORTATION AND PUBLIC WORKS
 HIGHWAY DIVISION
 STEPHEN P. CLARK CENTER
 111 NW 1 ST
 MIAMI, FLORIDA 33128

SW 57 AV & SW 72 ST
(SUMMARY OF QUANTITIES)
ASSET#: 3303

THE OFFICIAL RECORD OF THIS SHEET IS THE ELECTRONIC FILE DIGITALLY SIGNED AND SEALED UNDER RULE 61015-23.001(2)(9)-78PFC

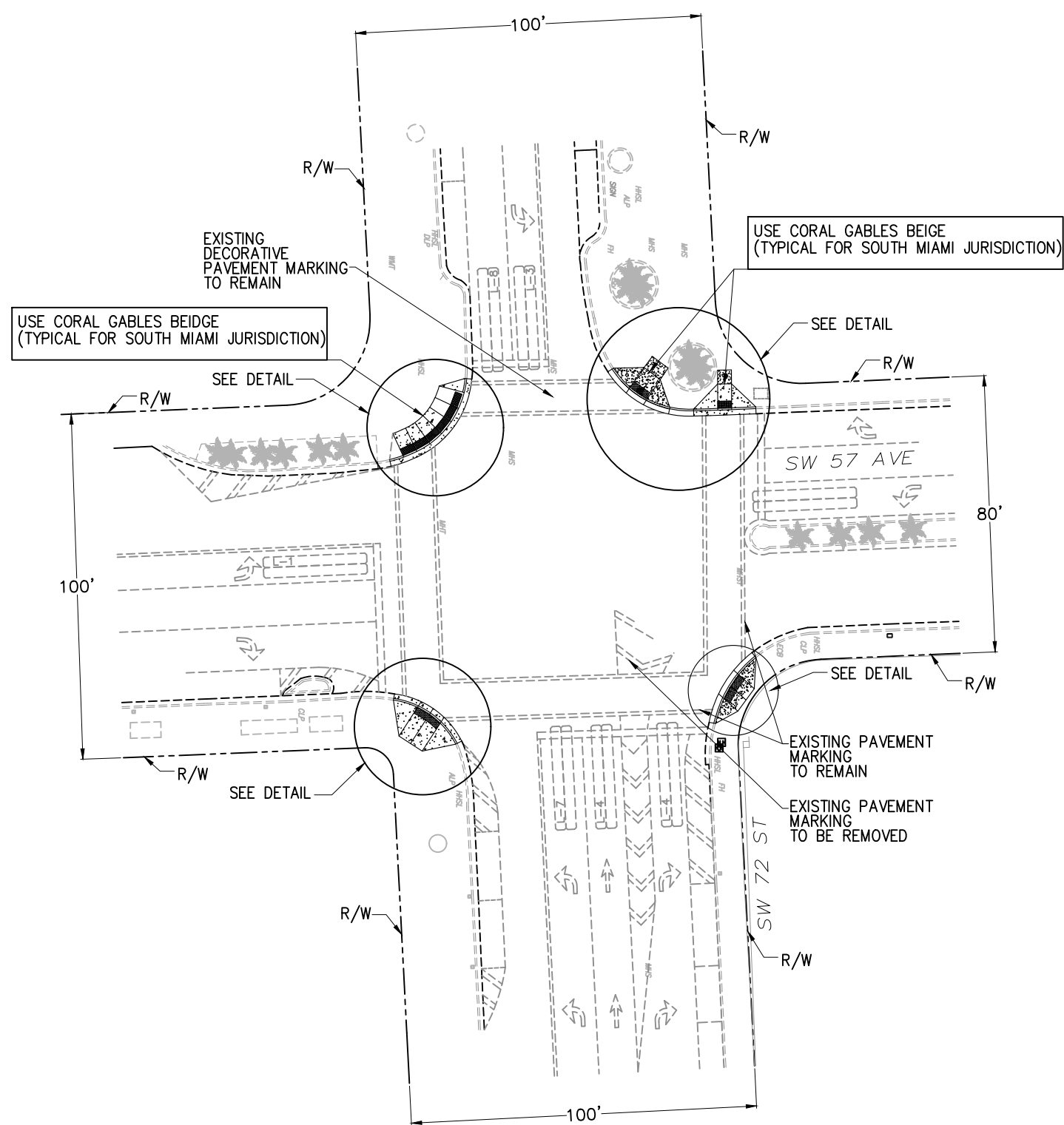
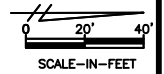

REVISIONS					
DATE	BY	DESCRIPTION	DATE	BY	DESCRIPTION

MIAMI-DADE COUNTY
 HIGHWAY DIVISION

DESIGNED BY	NAME	DATE	DRAWN BY	NAME	DATE
	W.Z	10/06/22		L.J.D	11/21/2022
CHECKED BY			CHECKED BY		
SUPERVISED BY: YANEK FERNANDEZ, P.E.					

DEPARTMENT OF TRANSPORTATION AND PUBLIC WORKS HIGHWAY DIVISION
 MIAMI-DADE COUNTY
 STEPHEN P. CLARK CENTER
 101 NW 1 ST
 MIAMI, FLORIDA 33128

SW 57 AV & SW 72 ST
 (SUMMARY OF QUANTITIES)
 ASSET#: 3303

THE OFFICIAL RECORD OF THIS SHEET IS THE ELECTRONIC FILE DIGITALLY SIGNED AND SEALED UNDER RULE 61G15-23.001(2)(c)-FPRE

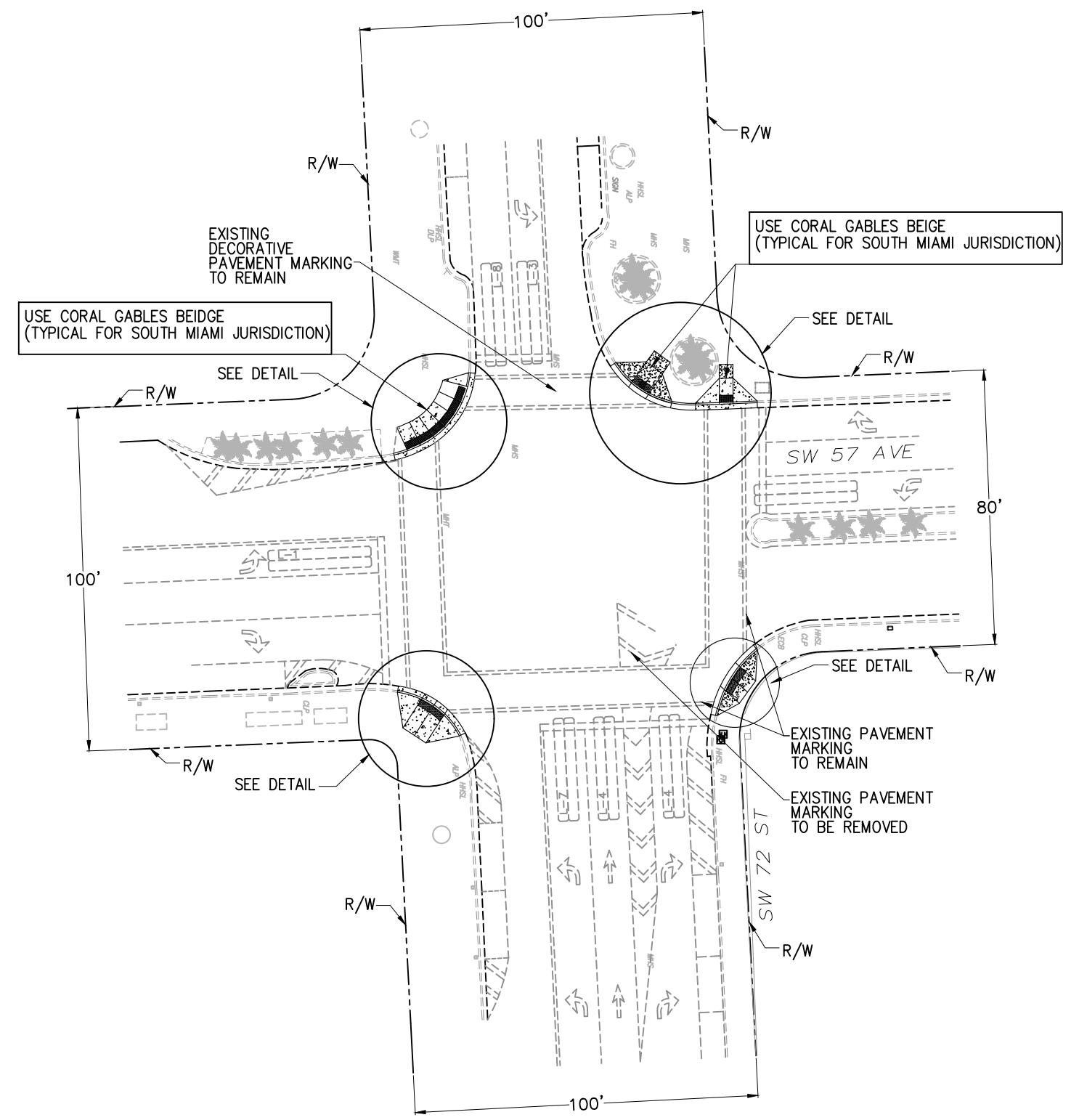
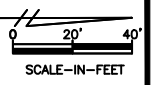

REVISIONS								
DATE	BY	DESCRIPTION	DATE	BY	DESCRIPTION	DATE	BY	DESCRIPTION

MIAMI-DADE COUNTY
 HIGHWAY DIVISION

NAME	DATE	NAME	DATE
DESIGNED BY: W.Z	10/06/22	DRAWN BY: L.J.D	11/21/2022
CHECKED BY:		CHECKED BY:	
SUPERVISED BY: YANEK FERNANDEZ, P.E.			

MIAMI-DADE COUNTY DEPARTMENT OF TRANSPORTATION AND PUBLIC WORKS HIGHWAY DIVISION
 STEPHEN P. CLARK CENTER
 111 NW 1 ST
 MIAMI, FLORIDA 33128

SW 57 AV & SW 72 ST
 (RAMP DETAILS)
 ASSET#: 3303

THE OFFICIAL RECORD OF THIS SHEET IS THE ELECTRONIC FILE DIGITALLY SIGNED AND SEALED UNDER RULE 61G05-23.001(2)(a)-FPBE

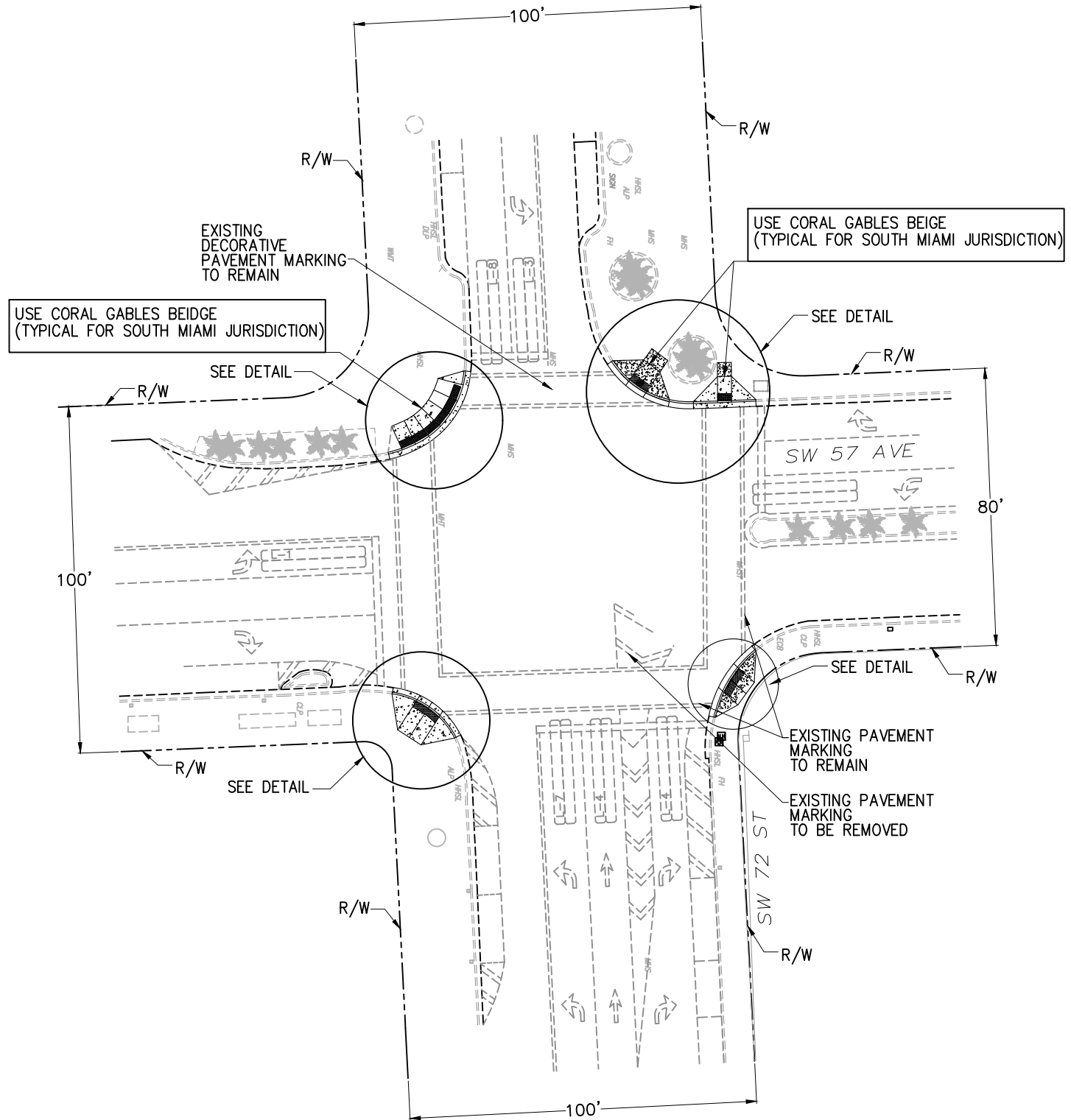
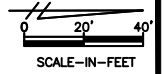

REVISIONS

DATE	BY	DESCRIPTION	DATE	BY	DESCRIPTION

MIAMI-DADE COUNTY
 HIGHWAY DIVISION

DESIGNED BY	NAME	DATE	DRAWN BY	NAME	DATE
	W.Z	10/06/22		L.J.D	11/21/2022
CHECKED BY			CHECKED BY		
SUPERVISED BY: YANEK FERNANDEZ, P.E.					

DEPARTMENT OF TRANSPORTATION AND PUBLIC WORKS HIGHWAY DIVISION
 MIAMI-DADE COUNTY
 STEPHEN P. CLARK, CENTER
 111 NW 1 ST
 MIAMI, FLORIDA 33128

SW 57 AV & SW 72 ST
 (SIGNING AND PAVEMENT MARKING PLAN)
 ASSET#: 3303

THE OFFICIAL RECORD OF THIS SHEET IS THE ELECTRONIC FILE DIGITALLY SIGNED AND SEALED UNDER RULE 61G15-23.001(2)(a)-FPBE

SIGNAL HEAD & SIGN DETAILS

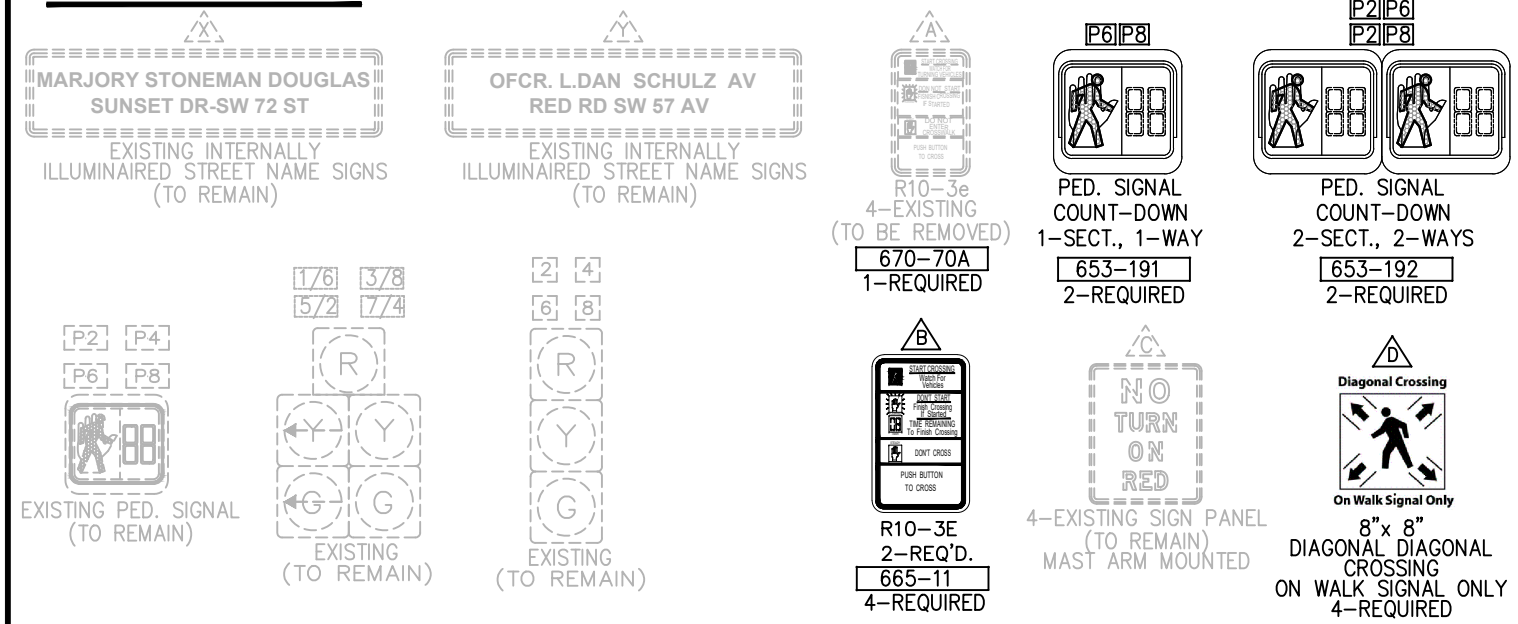

CONTROLLER OPERATIONS

1. MAJOR STREET IS SW 57 AV. MINOR STREET IS SW 72 ST.
2. PEDESTRIAN EXCLUSIVE PHASE UPON ACTUATION AND RUN 24 HOURS.
3. MOVEMENT 1,3,5,7 IS (ARE) PROTECTED/PERMISSIVE.
4. SIGNAL COORDINATION IS PHASE 3.
5. FLASHING OPERATION 2+6 YELLOW, 4+8 RED.

CONTROLLER TIMING REFERENCE TABLE								
VEHICLE MOVEMENT	1	2	3	4	5	6	7	8
APPROACH DIRECTION	NBL	SBT	EBL	WBT	SBL	NBT	WBL	EBT
APPROACH POSTED SPEED (MPH)	30	30	25	25	30	30	30	25
ALL RED DISTANCE (FEET)	70	94	90	86	92	90	72	84
YELLOW CLEARANCE	3.7	4.0	3.4	4.0	3.7	4.0	3.7	4.0
ALL RED	2.1	2.6	3.0	2.5	3.6	2.5	2.1	2.9
EXCLUSIVE PEDESTRIAN OPERATION TIMING								
FUNCTION								
PEDESTRIAN WALK	7							
PEDESTRIAN CLEARANCE INTERVAL	34							
PEDESTRIAN CROSSING DISTANCE	115'							

DETECTORS FOR LOOPS		
MVM T NO.	NO. OF LOOPS	NO. OF DETS.
1	1	1
2	2	1
3	1	1
4	2	1
6	2	1
7	1	1
8	2	1

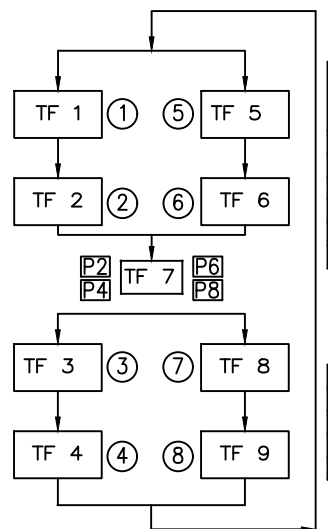

2070LX SIEMENS CONTROLLER AND CABINET 660X

670-5-140	1EA
635-2-11	7EA
620-1-1	40LF
639-2-1	180LF
635-2-15A	1EA
660-1-109C	7EA

FPL DISCONNECT

635-2-11	3EA
620-1-1	20LF
639-2-1	
639-3-11	

FPL SERVICE POINT

635-2-11	1 EA
±180' FROM CONTROL BOX	

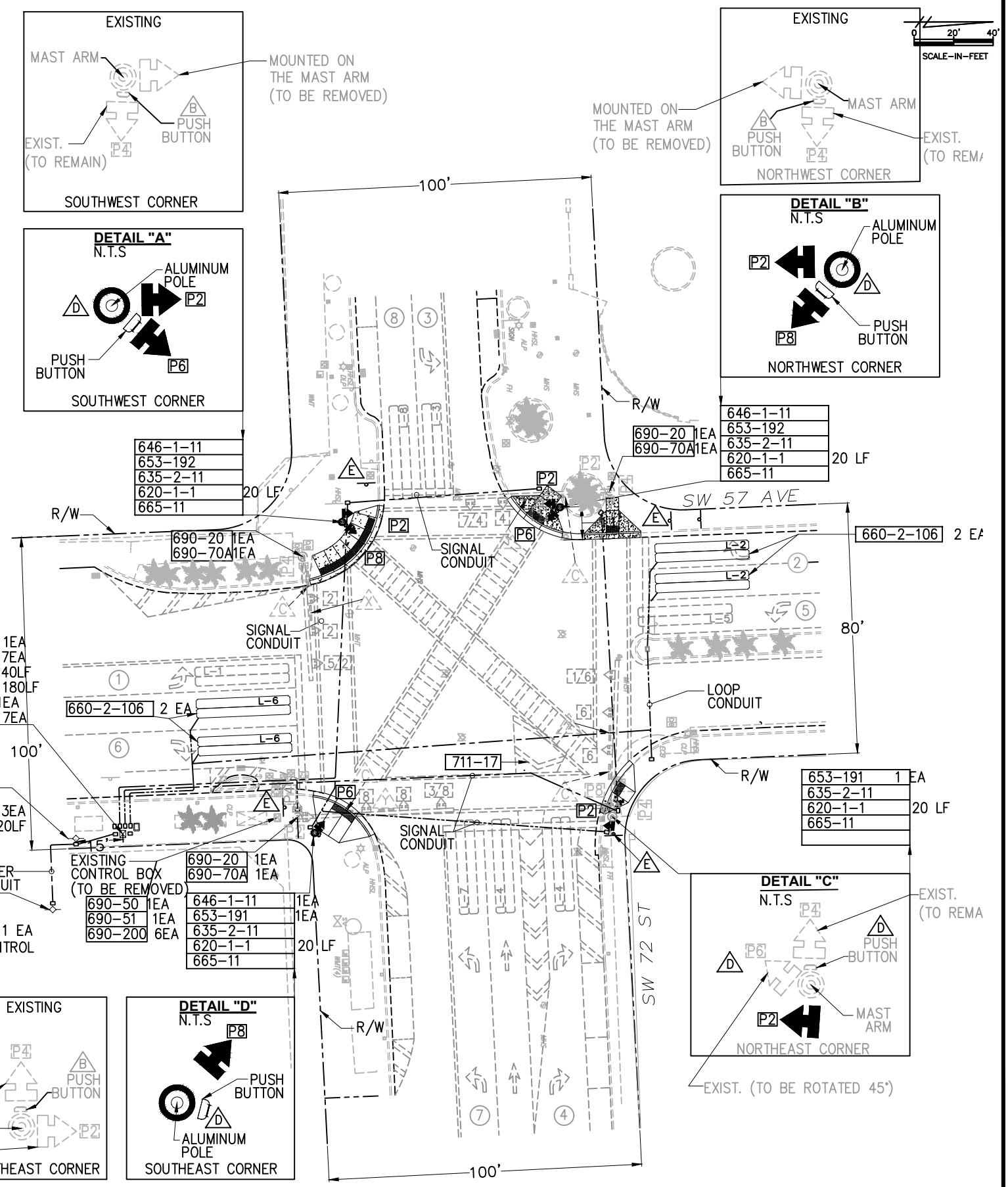
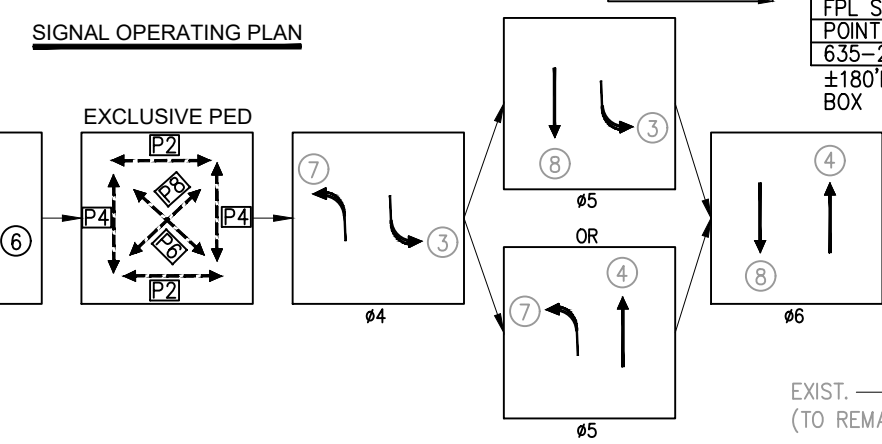
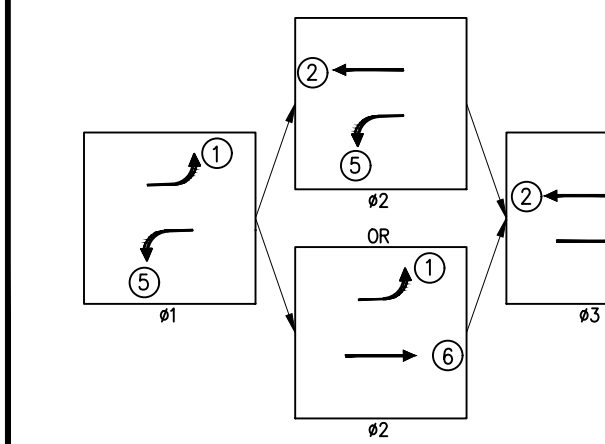

REVISIONS					
DATE	BY	DESCRIPTION	DATE	BY	DESCRIPTION

MIAMI-DADE COUNTY
 HIGHWAY DIVISION

DESIGNED BY	W.Z	DATE	10/06/22	DRAWN BY	L.J.D	DATE	11/21/2022
CHECKED BY				CHECKED BY			
SUPERVISED BY	YANEK FERNANDEZ, P.E.						

MIAMI-DADE COUNTY
 DEPARTMENT OF TRANSPORTATION AND PUBLIC WORKS
 HIGHWAY DIVISION
 STEPHEN P. CLARK CENTER
 111 NW 1 ST
 MIAMI, FLORIDA 33128

SW 57 AV & SW 72 ST
 (TRAFFIC SIGNAL)
 ASSET#: 3303

THE OFFICIAL RECORD OF THIS SHEET IS THE ELECTRONIC FILE DIGITALLY SIGNED AND SEALED UNDER RULE 6105-23.001(2)(a)-FBPE

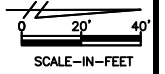

PHASE I
 RECONST. CURB RAMP, PLACE CABINET,
 NEW SERVICE POINT AND SE PEDESTAL WITH SIGNALS
 PEDESTRIAN MOT PER FDOT STANDARD INDEX 102-660 SHEET 1 OF 2
 SHOULDER CLOSURE MOT PER FDOT INDEX 102-602 SHEET 2 OF 2
 POLICE CONTROL AT SW 72 ST AND SW 55 AVE

- LEGEND:**
- WORKING ZONE
 - PEDESTRIAN PATH
 - CHANNELIZING DEVICES

TEMPORARY TRAFFIC CONTROL PLAN NOTES

1. LANE CLOSURE SHALL OCCUR ONLY DURING NON-PEAK HOURS ON NON-EVENT DAYS/WEEKENDS.
 NON-PEAK HOURS ARE: FROM 9:00 AM TO 3:00 PM. WEEKDAYS AND WEEKENDS.
2. TRAFFIC CONTROL PLANS ARE DESIGNED FOR NON-PEAK HOURS ONLY.
3. REGULATORY SPEED ESTABLISHED WITHIN THE WORK ZONE TRAVEL WAYS SHALL BE 15 MPH.

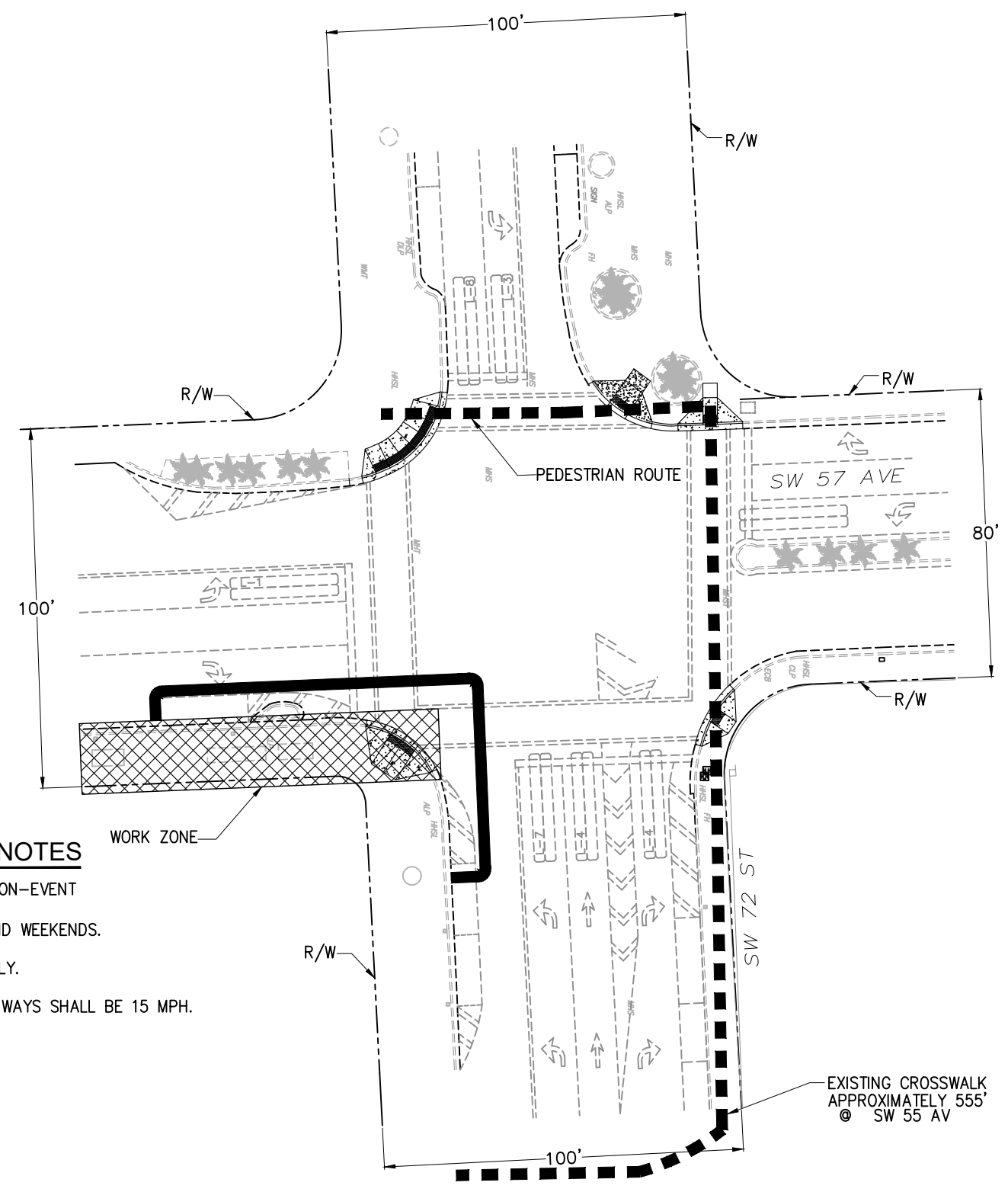

REVISIONS								
DATE	BY	DESCRIPTION	DATE	BY	DESCRIPTION	DATE	BY	DESCRIPTION

MIAMI-DADE COUNTY
 HIGHWAY DIVISION

NAME	DATE	NAME	DATE
DESIGNED BY: W.Z	10/06/22	DRAWN BY: L.J.D	11/21/2022
CHECKED BY:		CHECKED BY:	
SUPERVISED BY: YANEK FERNANDEZ, P.E.			

MIAMI-DADE COUNTY DEPARTMENT OF TRANSPORTATION AND PUBLIC WORKS HIGHWAY DIVISION
 STEPHEN P. CLARE, CENTER
 111 NW 1 ST
 MIAMI, FLORIDA 33128

TEMPORARY TRAFFIC CONTROL PLANS - PHASE I
 ASSET#: 3303

THE ORIGINAL RECORD OF THIS SHEET IS THE ELECTRONIC FILE DIGITALLY SIGNED AND SEALED UNDER RULE 61G15-23.001(2)(a)-FPBE

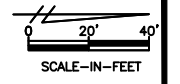

PHASE II
 RECONST. CURB RAMP AND PLACE NE PEDESTAL WITH SIGNALS
 PEDESTRIAN MOT PER FDOT STANDARD INDEX 102-660 SHEET 1 OF 2
 SHOULDER CLOSURE MOT PER FDOT INDEX 102-602 SHEET 2 OF 2

- LEGEND:**
- WORKING ZONE
 - PEDESTRIAN PATH
 - CHANALIZING DEVICES

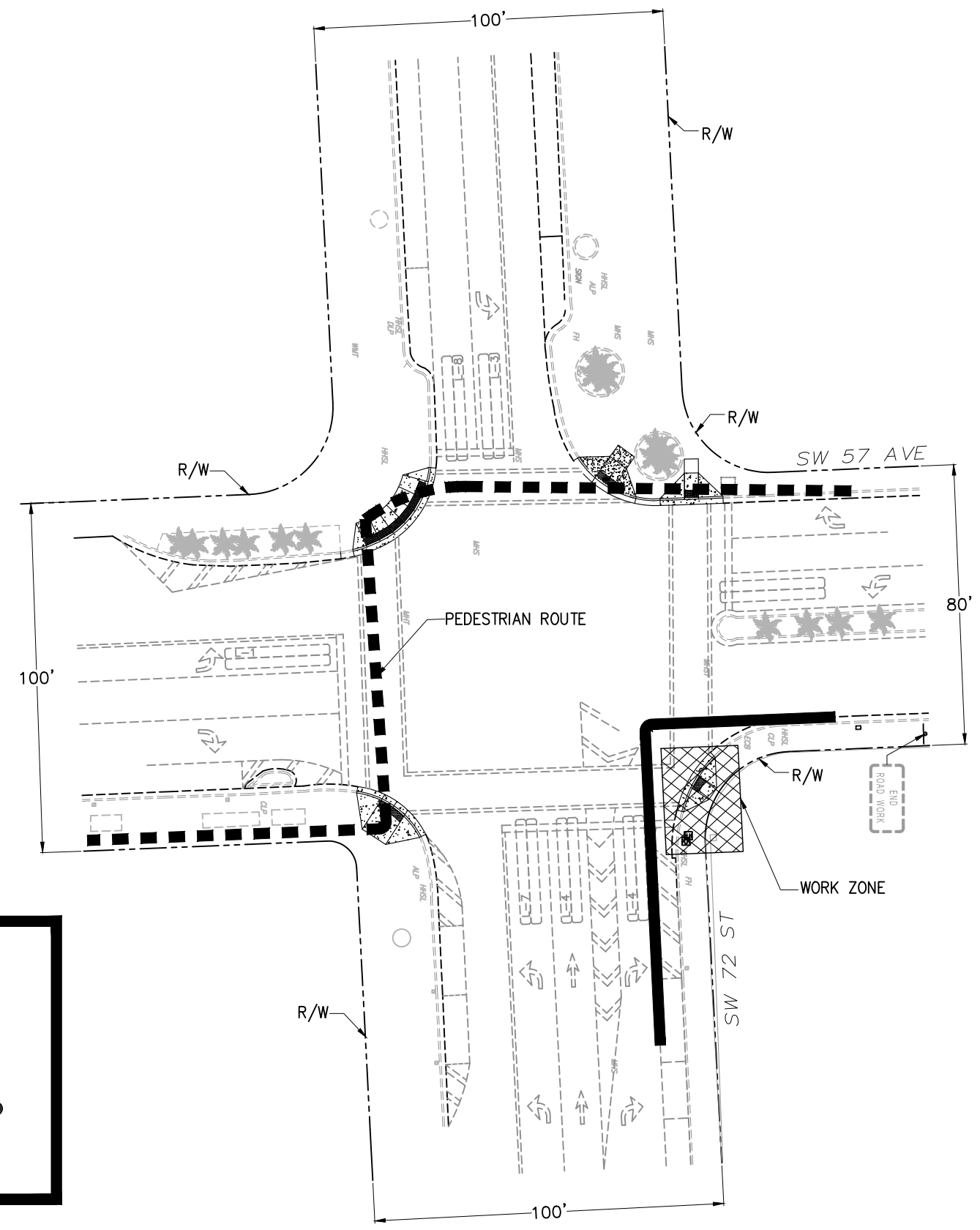
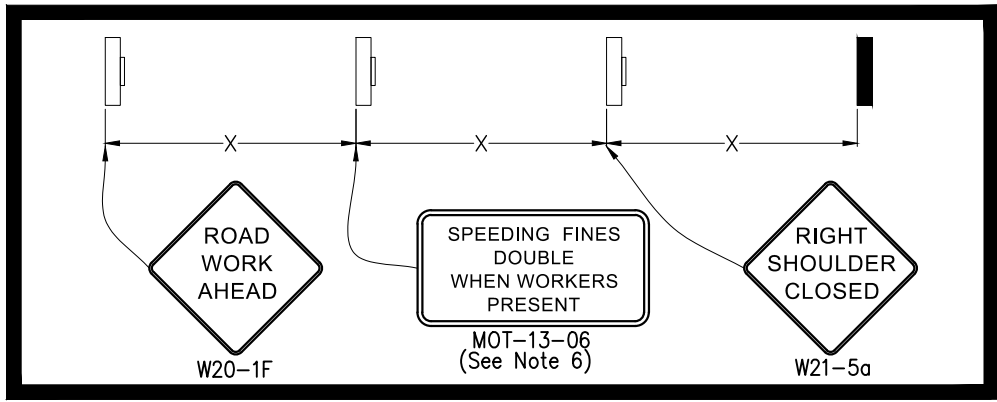

REVISIONS								
DATE	BY	DESCRIPTION	DATE	BY	DESCRIPTION	DATE	BY	DESCRIPTION

MIAMI-DADE COUNTY
 HIGHWAY DIVISION

DESIGNED BY	NAME	DATE	DRAWN BY	NAME	DATE
W.Z	10/06/22	L.J.D	11/21/2022		

CHECKED BY: YANEK FERNANDEZ, P.E.

DEPARTMENT OF TRANSPORTATION AND PUBLIC WORKS HIGHWAY DIVISION
 MIAMI-DADE COUNTY
 STEPHEN P. CLARK CENTER
 111 NW 1 ST
 MIAMI, FLORIDA 33128

TEMPORARY TRAFFIC CONTROL PLANS - PHASE II
 ASSET#: 3303

THE OFFICIAL RECORD OF THIS SHEET IS THE ELECTRONIC FILE DIGITALLY SIGNED AND SEALED UNDER RULE 61G19-23.001(2)(a)-FPPE

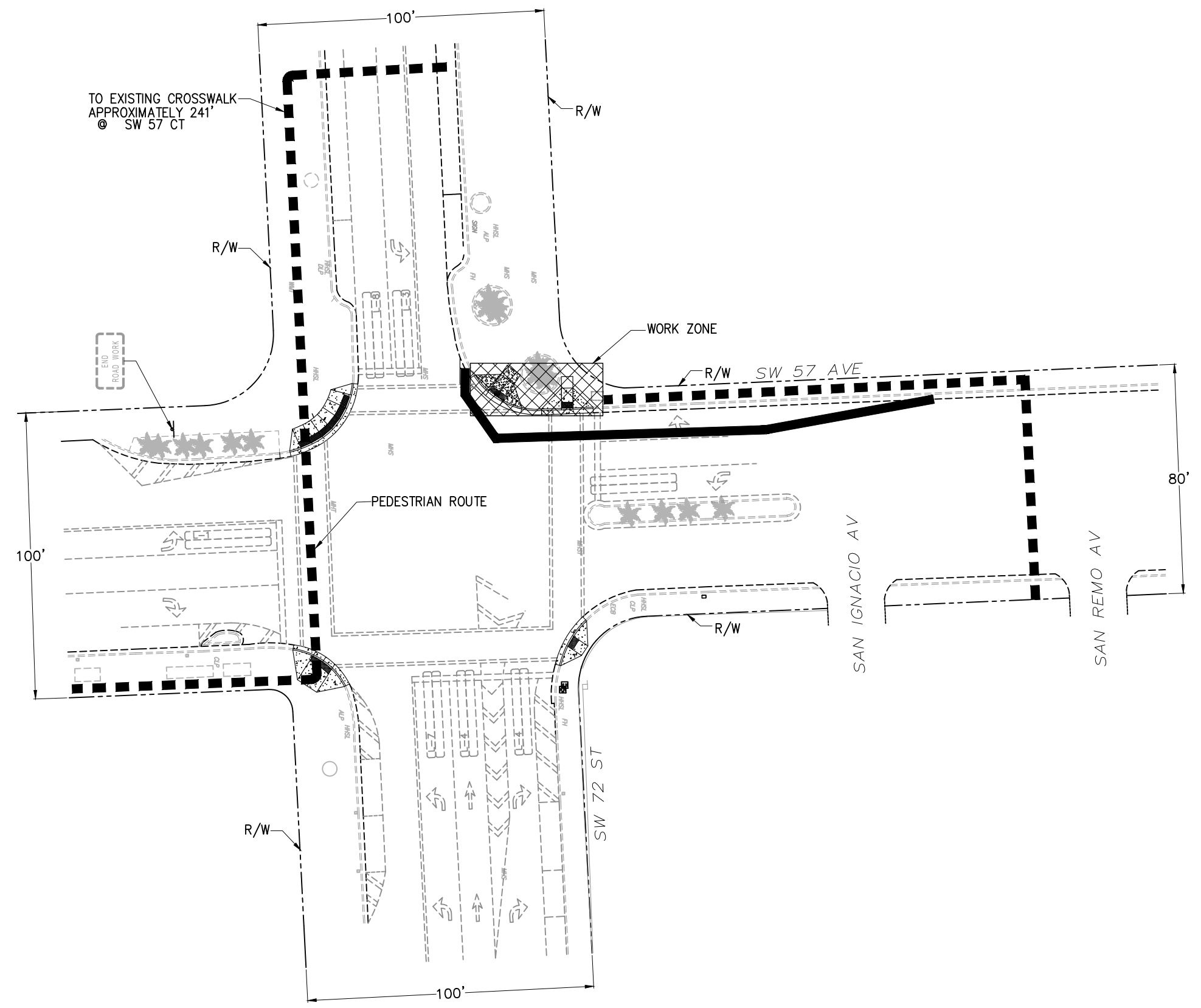
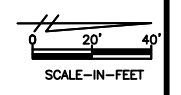

PHASE III
RECONST. CURB RAMP AND PLACE NW PEDESTAL WITH SIGNALS
PEDESTRIAN MOT PER FDOT STANDARD INDEX 102-660 SHEET 1 OF 2
SB LANE CLOSURE PER FDOT INDEX 102-613 SHEET 1 OF 5

- LEGEND:**
- WORKING ZONE
 - PEDESTRIAN PATH
 - CHANALIZING DEVICES

REVISIONS								
DATE	BY	DESCRIPTION	DATE	BY	DESCRIPTION	DATE	BY	DESCRIPTION

MIAMI-DADE COUNTY
 HIGHWAY DIVISION

NAME	DATE	NAME	DATE
DESIGNED BY: W.Z	10/06/22	DRAWN BY: L.J.D	11/21/2022
CHECKED BY:		CHECKED BY:	
SUPERVISED BY: YANEK FERNANDEZ, P.E.			

MIAMI-DADE COUNTY DEPARTMENT OF TRANSPORTATION AND PUBLIC WORKS HIGHWAY DIVISION
 STEPHEN R. CLARK CENTER
 111 NW 1 ST
 MIAMI, FLORIDA 33128

TEMPORARY TRAFFIC CONTROL PLANS - PHASE III
 ASSET#: 3303

THE OFFICIAL RECORD OF THIS SHEET IS THE ELECTRONIC FILE DIGITALLY SIGNED AND SEALED UNDER RULE 61G15-23.001(2)(g)-FPBE

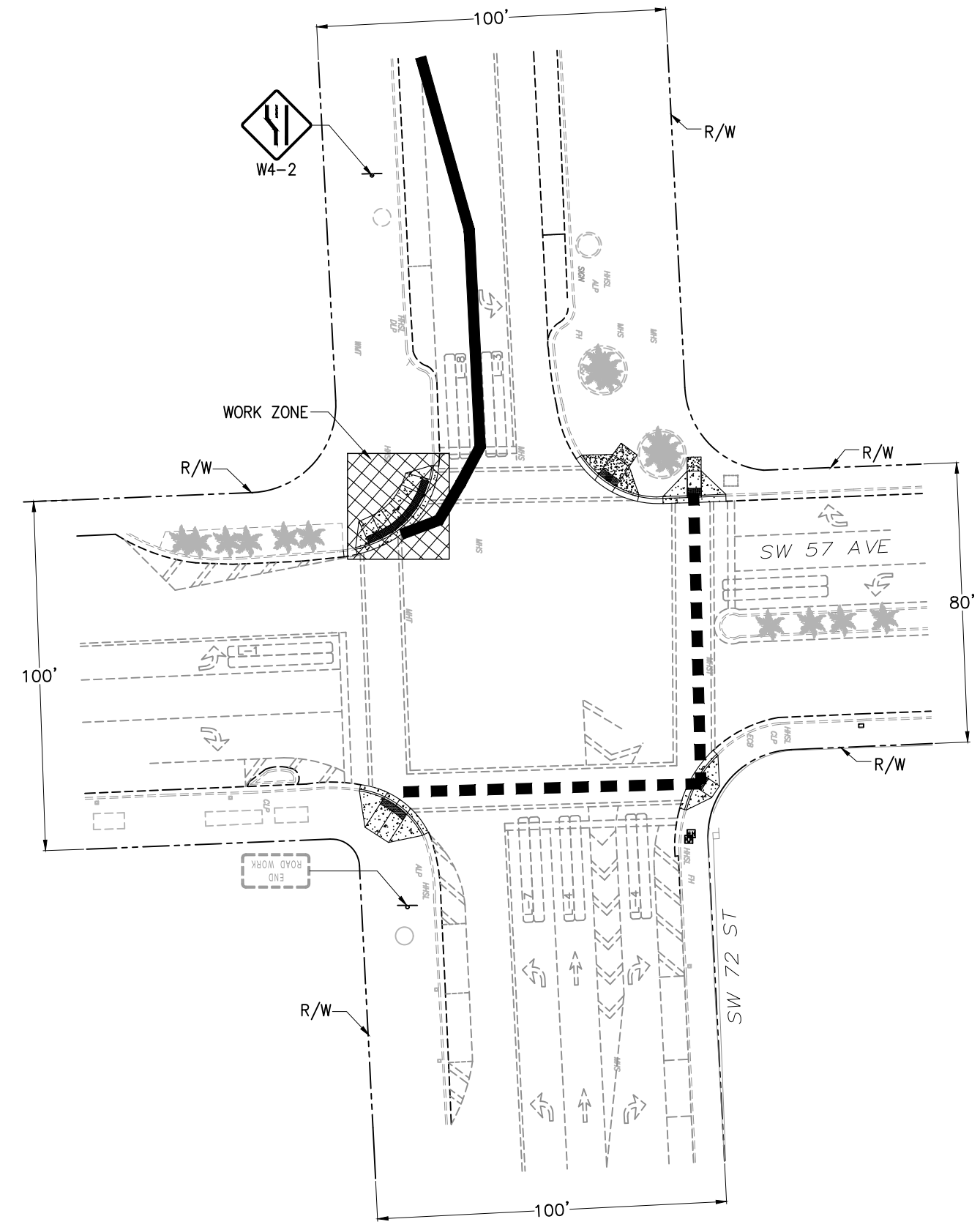
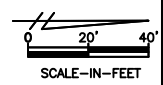

PHASE IV
 RECONST. CURB RAMP AND PLACE SW PEDESTAL WITH SIGNALS
 PEDESTRIAN MOT PER FDOT STANDARD INDEX 102-660 SHEET 1 OF 2
 SHOULDER CLOSURE MOT PER FDOT INDEX 102-602 SHEET 2 OF 2

- LEGEND:**
- WORKING ZONE
 - PEDESTRIAN PATH
 - CHANALIZING DEVICES

REVISIONS					
DATE	BY	DESCRIPTION	DATE	BY	DESCRIPTION

MIAMI-DADE COUNTY
 HIGHWAY DIVISION

NAME	DATE	NAME	DATE
DESIGNED BY: W.Z	10/06/22	DRAWN BY: L.J.D	11/21/2022
CHECKED BY:		CHECKED BY:	
SUPERVISED BY: YANEK FERNANDEZ, P.E			

DEPARTMENT OF TRANSPORTATION AND PUBLIC WORKS HIGHWAY DIVISION
 MIAMI-DADE COUNTY
 STEPHEN P. CLARK, CENTER
 111 NW 1 ST
 MIAMI, FLORIDA 33128

TEMPORARY TRAFFIC CONTROL PLANS - PHASE IV
 ASSET#: 3303

THE OFFICIAL RECORD OF THIS SHEET IS THE ELECTRONIC FILE DIGITALLY SIGNED AND SEALED UNDER RULE 81G01-23.001(2)(a)-BPE

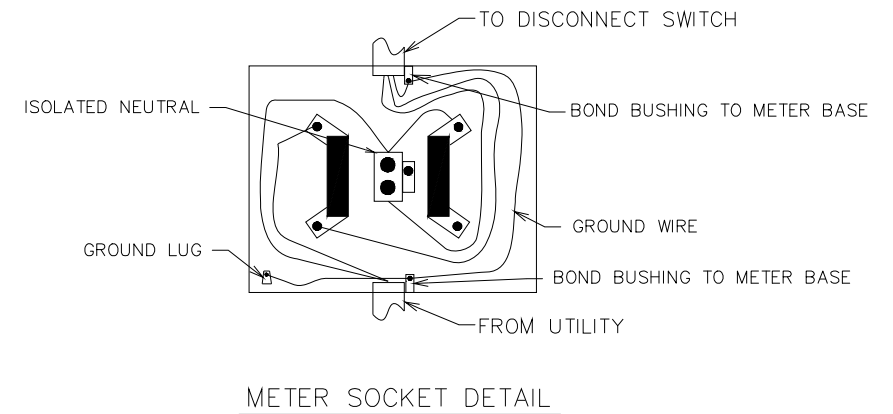
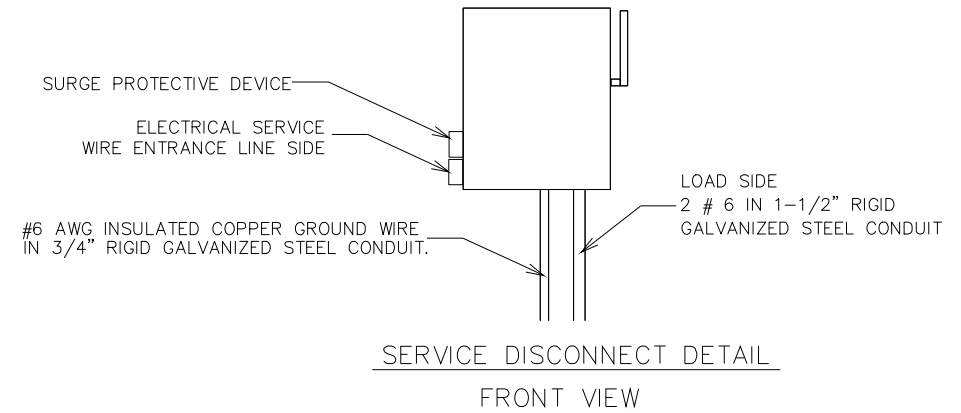
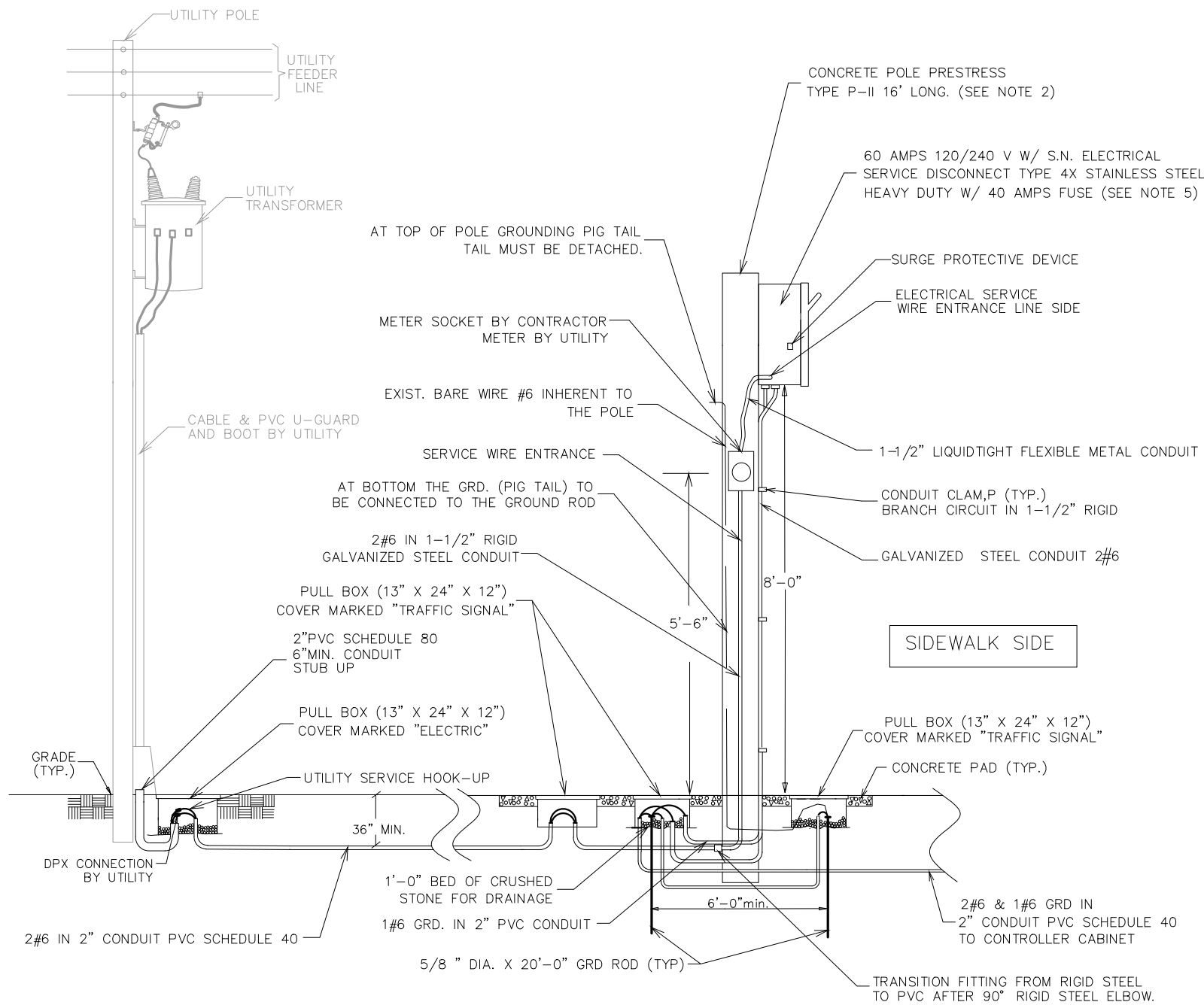

NOTES

1. CONTRACTOR MUST COORDINATE WITH ELECTRICAL POWER COMPANY (UTILITY) ENGINEERS FOR THE INSTALLATION OF THE UTILITY RISER.
2. STRUCTURAL CALCULATIONS OF THE POLE INSTALLATION, SIGNED AND SEALED BY A FLORIDA LICENSED PROFESSIONAL ENGINEER, MAY BE REQUIRED.
3. INTERCONNECT ALL GROUNDING ELECTRODES USING #6 GROUNDING CONDUCTOR.
4. PROVIDE SUPPLEMENTARY GROUNDING ELECTRODE SPACED AT A MINIMUM OF 6FT APART.
5. SERVICE DISCONNECT MUST BE RATED FOR SERVICE ENTRANCE. LABEL MUST BE FACTORY INSTALLED.
6. SERVICE DISCONNECT TO BE ORIENTED ON CONCRETE POLE SO ITS FACING THE SIDEWALK.
7. METER TO BE ORIENTED ON SIDE OF CONCRETE POLE SO WHEN READING IT YOU ARE FACING ON-COMING TRAFFIC.
8. PROVIDE 2 FEET OF COILED TERMINATION OF CONDUCTOR IN THE PULLBOX MARKED "ELECTRIC".
9. TERMINATE CONDUITS IN METER SOCKET AND SERVICE DISCONNECT WITH INSULATED GROUNDING BUSHING WITH SOLDERLESS LUG.

S:\Vector\Lisa H\2021\MIAMI\639-SPEC-DETAIL_2-25-21.dwg Mar 09, 2021 - 9:17am E139108

LATEST REVISION 02/25/21	DESCRIPTION: TRAFFIC CONTROL EQUIPMENT STANDARDS AND SPECIFICATIONS		TRAFFIC SIGNALS AND SIGNS DIVISION 7100 NW 36th STREET MIAMI, FLORIDA 33166 305.592.3580	<table border="1"> <tr> <td>NAME</td> <td>DATE</td> </tr> <tr> <td>DRAWN BY: HECTOR SANCHEZ</td> <td>02-13-20</td> </tr> <tr> <td>CHECKED BY: NAHUM FERNANDEZ</td> <td>02-13-20</td> </tr> <tr> <td colspan="2">APPROVED BY: FRANK ARA, P.E.</td> </tr> </table>	NAME	DATE	DRAWN BY: HECTOR SANCHEZ	02-13-20	CHECKED BY: NAHUM FERNANDEZ	02-13-20	APPROVED BY: FRANK ARA, P.E.		ELECTRICAL POWER SERVICE ASSEMBLY TYPICAL DETAILS (N.T.S.)	SHEET NO. 639-5
NAME	DATE													
DRAWN BY: HECTOR SANCHEZ	02-13-20													
CHECKED BY: NAHUM FERNANDEZ	02-13-20													
APPROVED BY: FRANK ARA, P.E.														

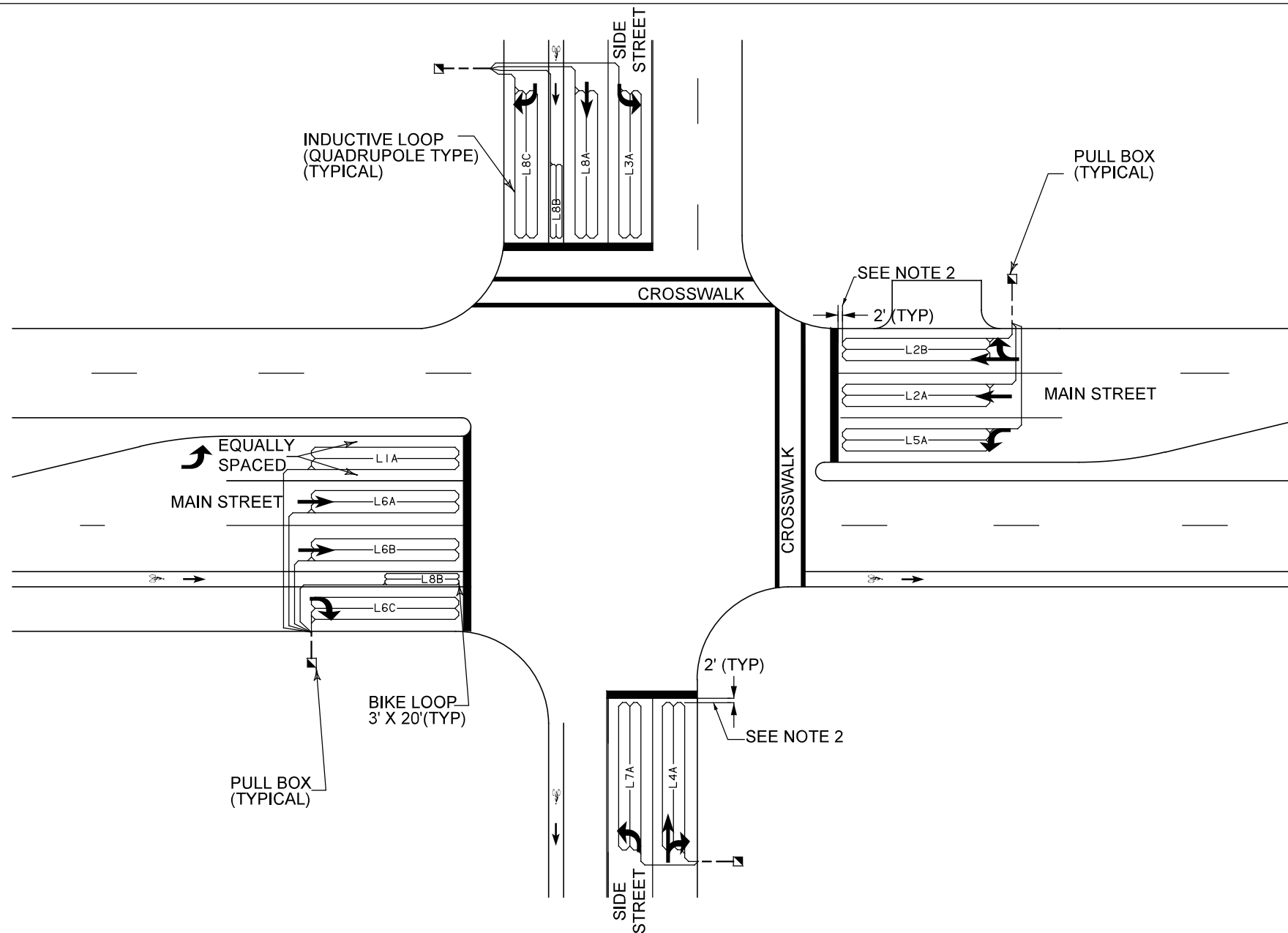

TYPICAL INDUCTIVE LOOP PLACEMENT
NOT TO SCALE

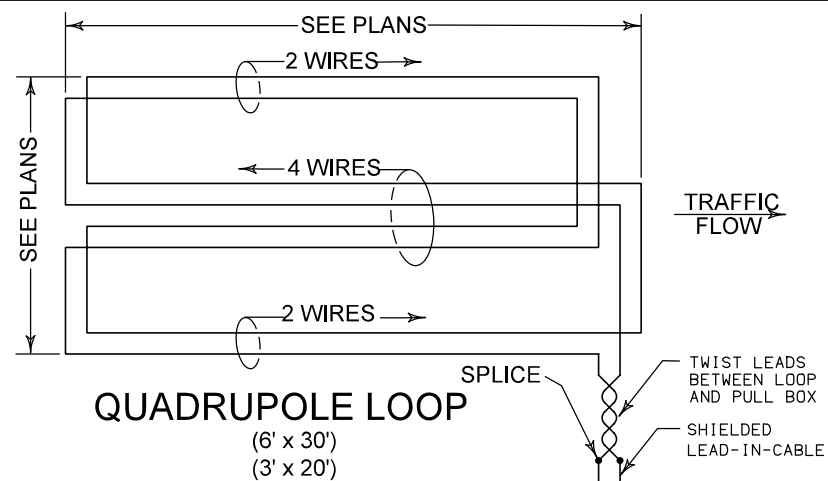

TYPICAL DETECTOR LOOP WIRE CONFIGURATION
NOT TO SCALE

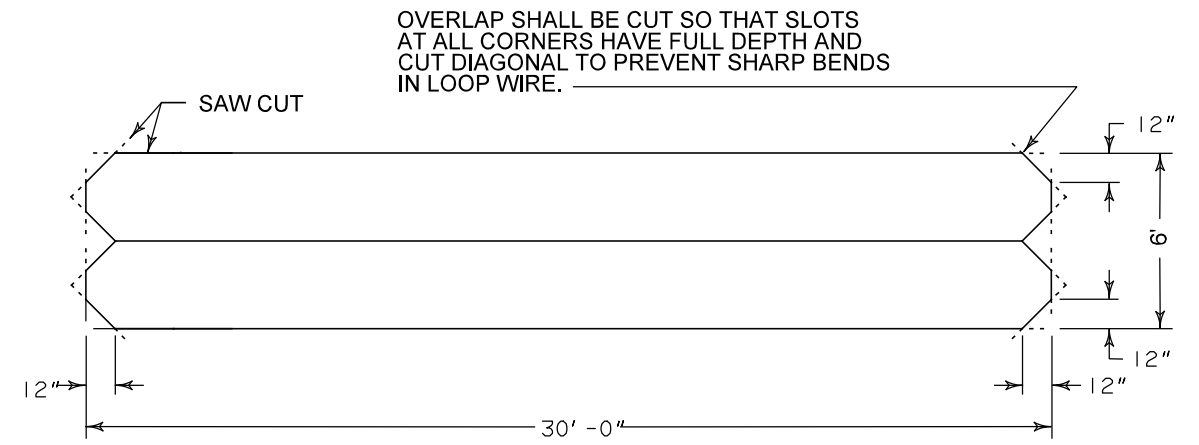

TYPICAL "TYPE F" VEHICLE INDUCTIVE LOOP
NOT TO SCALE

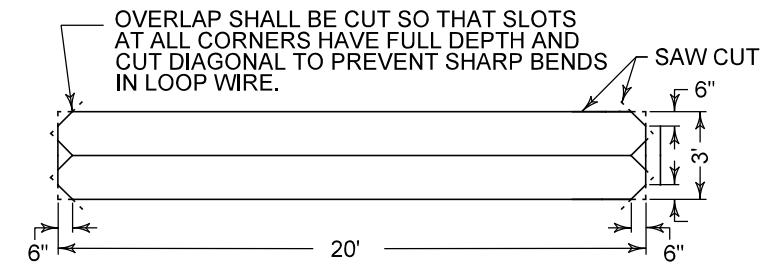

TYPICAL "TYPE F" MODIFIED BICYCLE INDUCTIVE LOOP
NOT TO SCALE

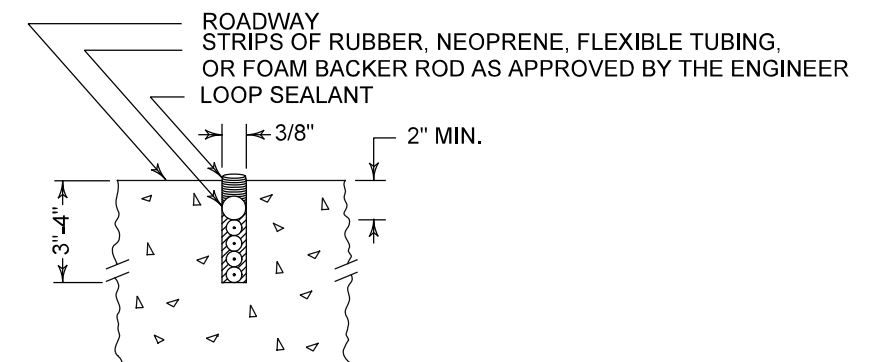

LOOP SECTION
NOT TO SCALE

TYPICAL SAW CUT DETAIL

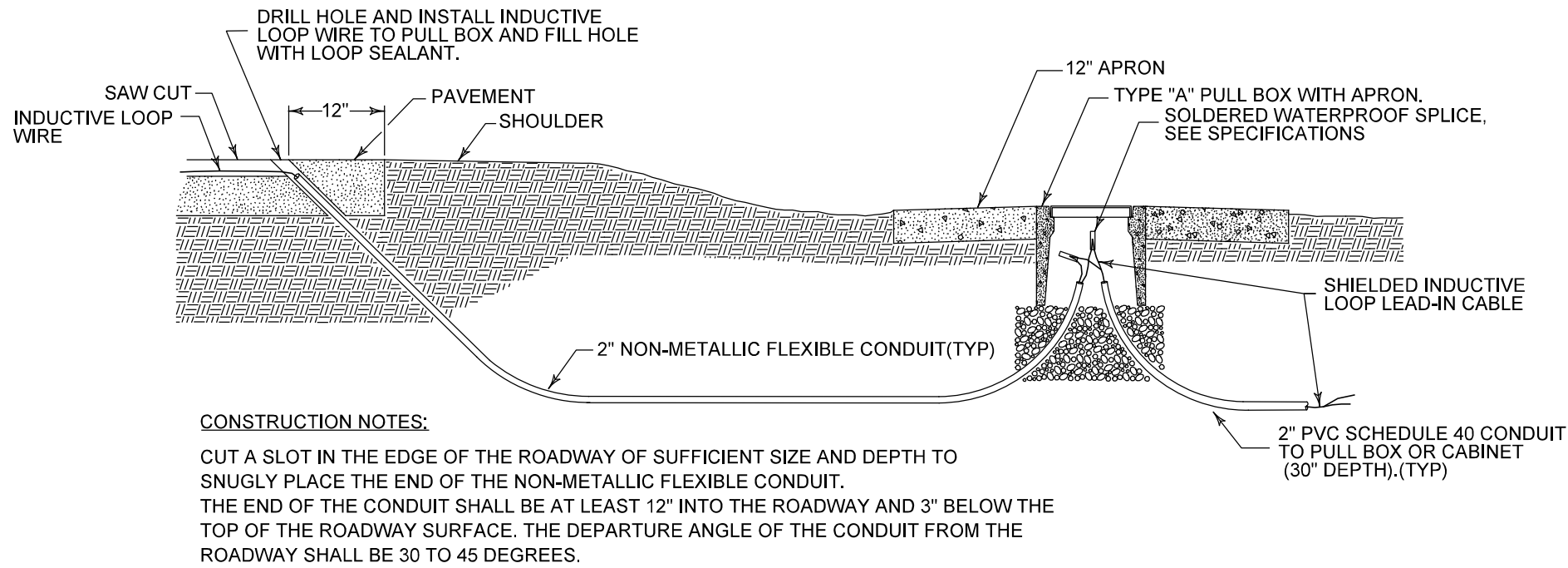

TYPICAL SECTION VIEW OF INDUCTIVE LOOP WIRE THROUGH PAVEMENT TO PULL BOX.

NOT TO SCALE

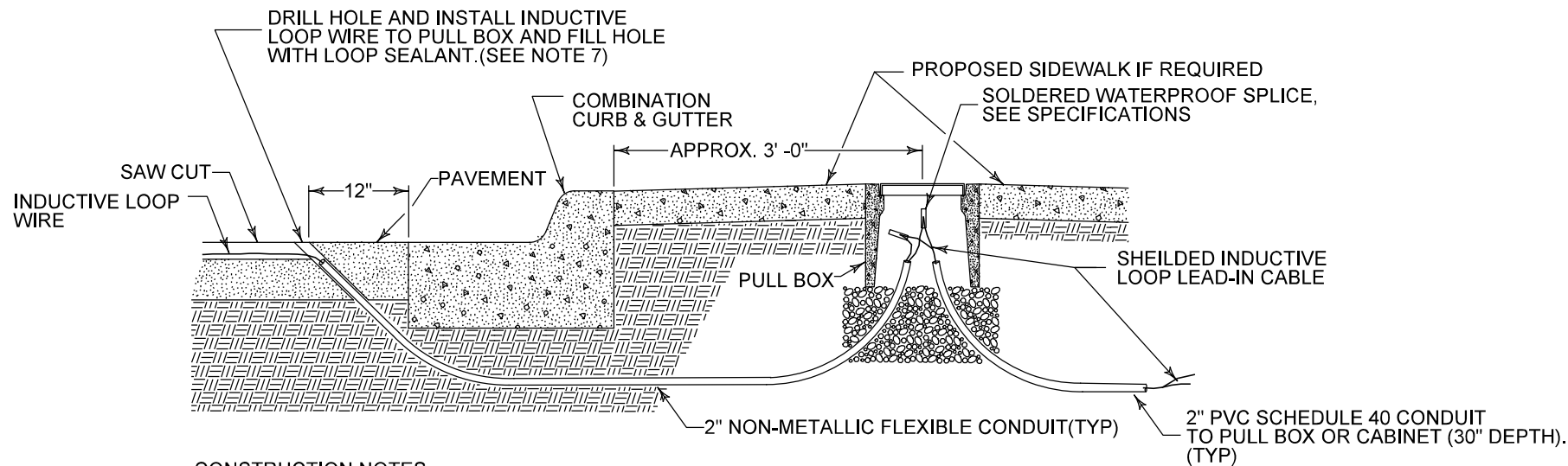

TYPICAL SECTION VIEW OF INDUCTIVE LOOP WIRE THROUGH CURB TO PULL BOX.

NOT TO SCALE

GENERAL NOTES:

1. MEET THE REQUIREMENTS OF MIAMI-DADE COUNTY TRAFFIC CONTROL EQUIPMENT STANDARDS AND SPECIFICATIONS SECTION 660 (VEHICLE DETECTION SYSTEMS).
2. THE STANDARD PLACEMENT OF THE LEADING EDGE OF TYPE F LOOP IS TWO FEET BEFORE THE STOP BAR BUT MAY EXTEND A MAXIMUM OF 10 FEET PAST THE STOP BAR TO MEET SITE-SPECIFIC ENGINEERING REQUIREMENTS. EACH INTERSECTION MUST BE INDIVIDUALLY DESIGNED AND IF THE AFOREMENTIONED MODIFICATION IS REQUIRED IT MUST BE NOTED OR DETAILED IN THE PLANS. UNDER NO CIRCUMSTANCES MAY THE LOOP OR SAW-CUT ENCROACH INTO A CROSSWALK.
3. IF THE LOOP LEAD-IN IS 75' OR LESS FROM THE EDGE OF THE LOOP DETECTOR TO CONTROLLER CABINET, CONTINUE THE TWISTED PAIR TO THE CABINET. IF THE LOOP LEAD-IN IS GREATER THAN 75' CONTINUE THE TWISTED PAIR TO THE SPECIFIED PULL BOX, SPLICE TO SHIELDED LEAD-IN WIRE AND CONTINUE TO THE CONTROLLER CABINET.
4. THE WIDTH OF ALL SAW CUTS SHALL BE SUFFICIENT TO ALLOW UNFORCED PLACEMENT OF LOOP WIRES OR LEAD-IN CABLES INTO THE SAW CUT. THE DEPTH OF ALL SAW CUTS, EXCEPT ACROSS EXPANSION JOINTS SHALL BE STANDARD 3 INCHES WITH A MAXIMUM OF 4 INCHES.
5. LOOP LEAD-IN WIRES MUST NOT BE INSTALLED IN THE SAME PULL BOX WITH SIGNAL POWER CABLES.
6. THE MINIMUM DISTANCE BETWEEN THE TWISTED PAIRS OF LOOP LEAD-IN WIRE IS 6 INCH FROM THE LOOP TO 12 INCH FROM THE PAVEMENT EDGE OR CURB.
7. THE MAXIMUM AREA OF ASPHALT TO BE DISTURBED SHALL BE 4"X 4". THIS AREA SHALL BE RESTORED AS DIRECTED BY THE ENGINEER.
8. LOOP LEAD-IN WIRES MUST BE 6 INCHES APART WHERE THERE ARE MULTIPLE LOOPS.

LATEST REVISION

DESCRIPTION:

03/27/17

TRAFFIC CONTROL EQUIPMENT STANDARDS AND SPECIFICATIONS



DTPW TRAFFIC SIGNALS AND SIGNS DIVISION
 7100 NW 36th STREET
 MIAMI, FLORIDA 33166
 305.592.3580

NAME	DATE
DRAWN BY TRAVIS BREWER	09-29-16
CHECKED BY NAHUM FERNANDEZ	03-22-17
APPROVED BY: FRANK AIRA, P.E.	

TYPICAL INDUCTIVE LOOP INSTALLATION DETAILS (N.T.S.)

SHEET No.

2 of 2

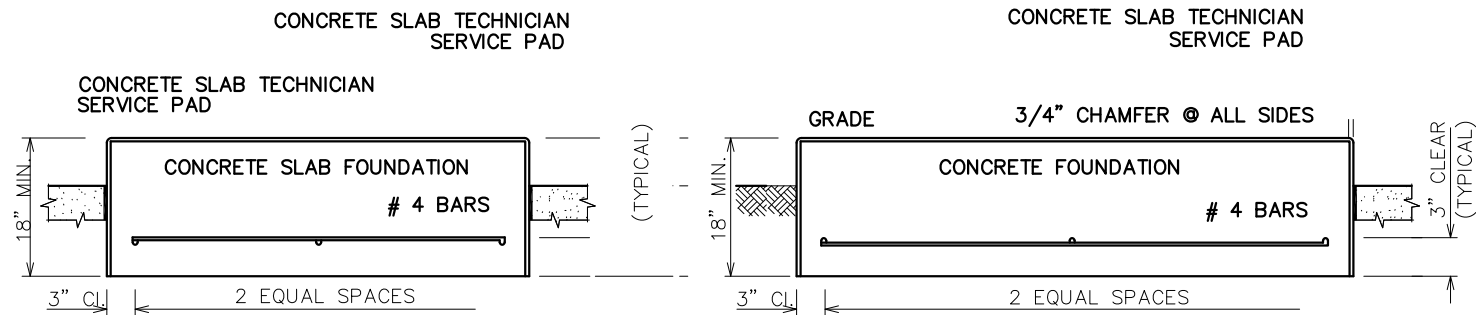

SECTION A-A

SECTION B-B

CONCRETE SLAB TECHNICIAN SERVICE PAD REINFORCING ELEVATION VIEW

N.T.S.

1" CHAMFER (TYPICAL ALL CORNERS)

CABINET CONCRETE FOUNDATION DETAIL

N.T.S.

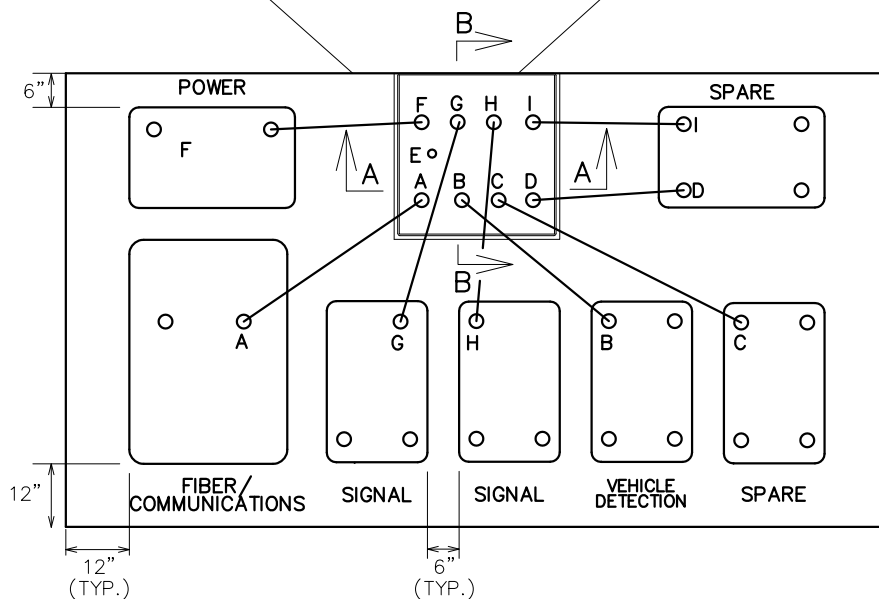
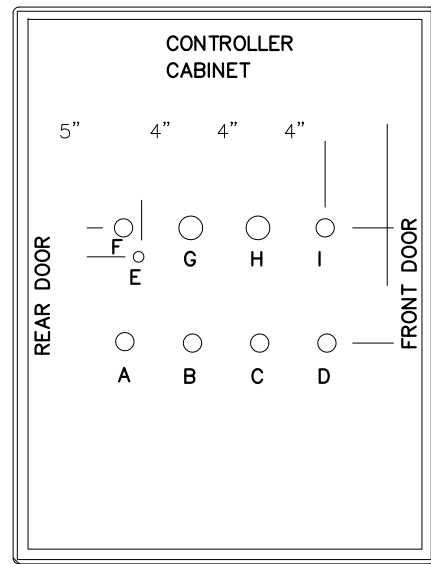

CONTROLLER CABINET WITH TECHNICIAN SERVICE PAD PLAN VIEW

N.T.S.

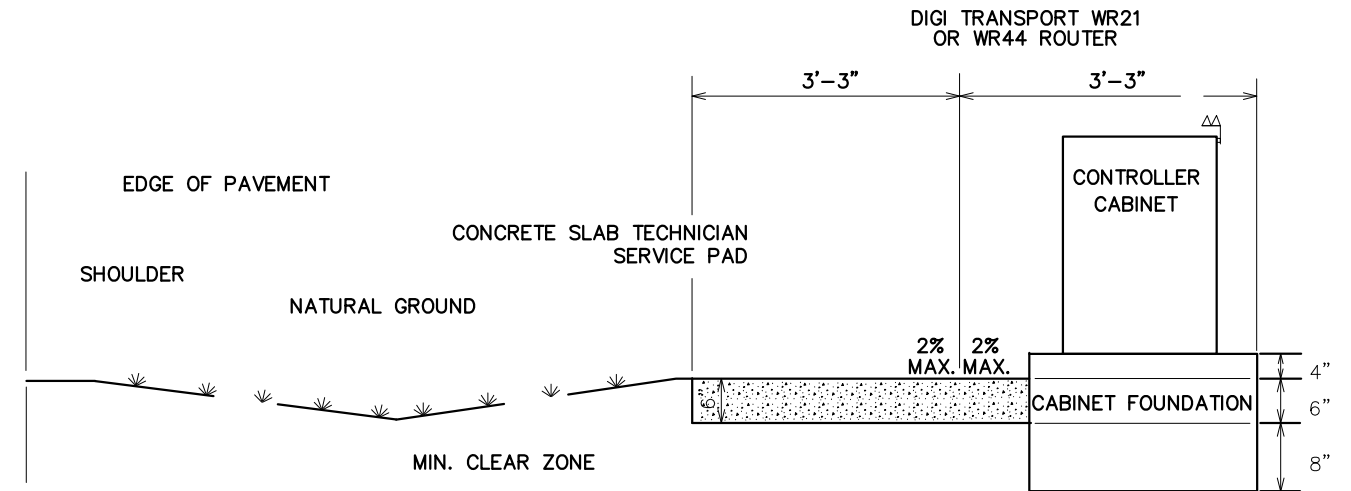

TYPICAL PLACEMENT DETAIL FOR SHOULDER MOUNT CONTROLLER CABINET

N. T. S.

NOTES:

1. NO DEVIATION FROM LAYOUT. LOCATION OF CONDUIT SHALL NOT CHANGE FROM DESIGNATED PULLBOX.
2. CONCRETE SLAB TECHNICIAN SERVICE PAD SHALL BE AT THE SAME ELEVATION AS THE ROADWAY CROWN.

DESIGNER NOTES FOR DIGI MODEM:

ADD PAY ITEM NOTE: COST OF COMPLETE INSTALLATION OF THE DIGI MODEM TO BE PAID UNDER PAY ITEM FOR NEW CONTROLLER CABINET COMPLETE PROPRIETARY PRODUCT CERTIFICATION FORM

DESIGNATION	TYPE	FUNCTION
A	2" PVC	FIBER/COMMUNICATIONS
B	2" PVC	VEHICLE DETECTION
C	2" PVC	SPARE
D	2" PVC	SPARE
E	1" PVC	GROUND ROD
F	2" PVC	POWER
G	3" PVC	SIGNAL CABLE
H	3" PVC	SIGNAL CABLE
I	2" PVC	SPARE

TRAFFIC ENGINEERING CHECK OFF BOX				REV	DATE	DESCRIPTION
TITLE	NAME	DATE				



TRAFFIC CONTROL INSTALLATION DETAIL

GENERAL NOTES

W. Salazar	2/11/2020
DESIGN	DATE

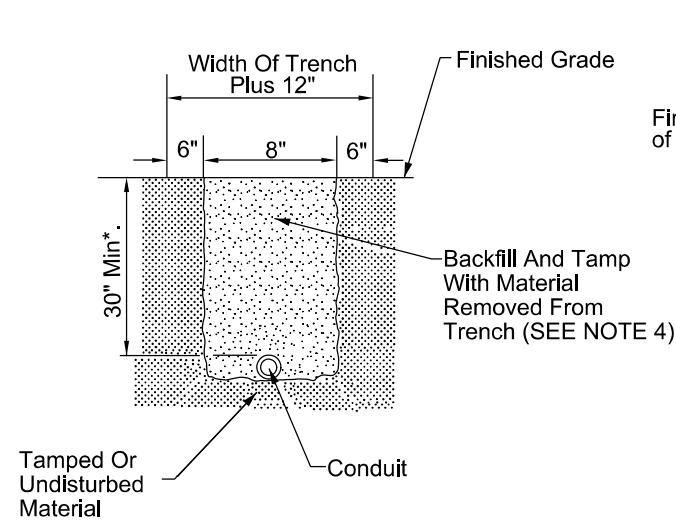

FOR USE IN AREAS NOT EXPOSED TO VEHICULAR TRAFFIC

FIGURE A

Notes:

1. Sidewalk patches to match existing joints.
2. Entire sidewalk slab must be replaced when specified in the plans.
3. Backfill and tamp with material from trench except at driveways. At driveways, backfill a length of trench within the driveway entirely with Flowable Fill.
4. Remove and replace additional pavement within 6" of trench.

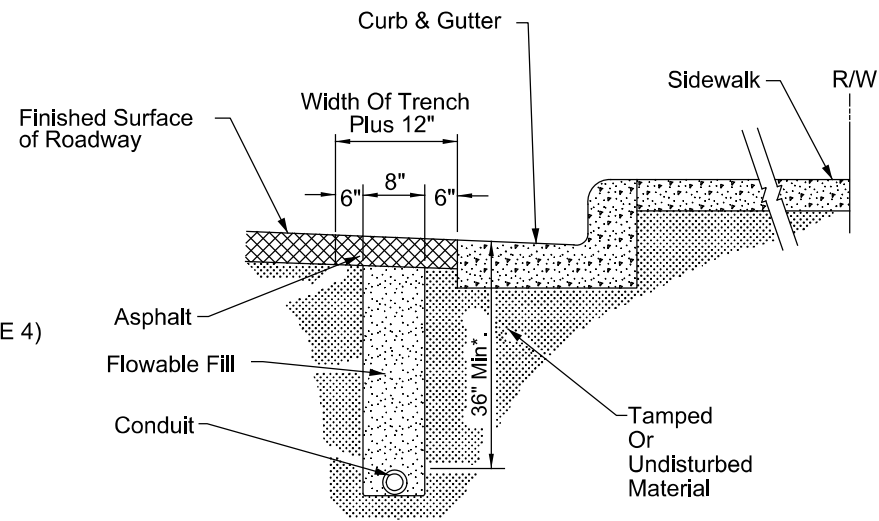

FOR USE IN ASPHALT ROADWAY ADJACENT TO GUTTER WHEN PLACEMENT OUTSIDE OF THE PAVEMENT IS NOT FEASIBLE.

FIGURE B

Notes:

1. Trench not to be open more than 250' at a time when construction area is subject to vehicular or pedestrian traffic.
2. Asphalt to be sawcut to leave neat lines at the pavement cut.

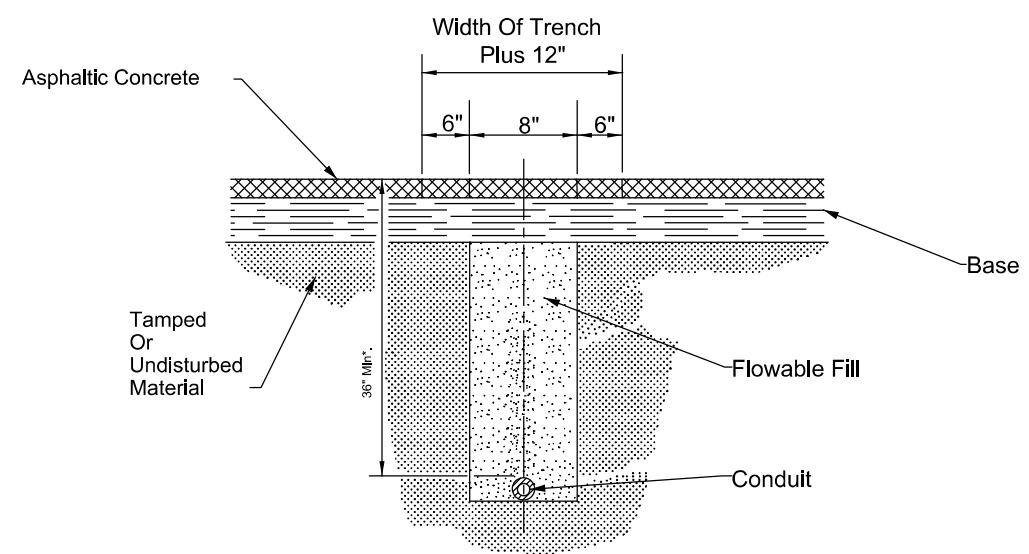

FOR USE IN INSTALLING CONDUIT UNDER EXISTING ASPHALT PAVEMENT NOT ADJACENT TO GUTTER WHEN JACKING OR DIRECT BORING IS NOT FEASIBLE

FIGURE C

Notes:

1. Rigid conduit must be used when jacking under existing pavement at 36" minimum depth.
2. Asphalt to be sawcut at the edges of the trench.

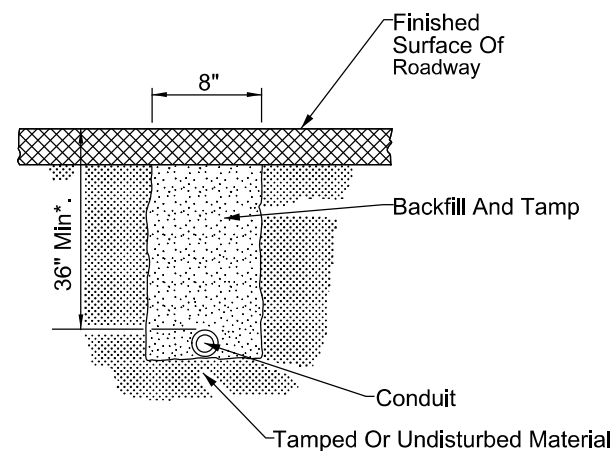

FOR USE INSTALLING CONDUIT UNDER A NEW ROADWAY PRIOR TO INSTALLATION OF BASE AND PAVEMENT

FIGURE D

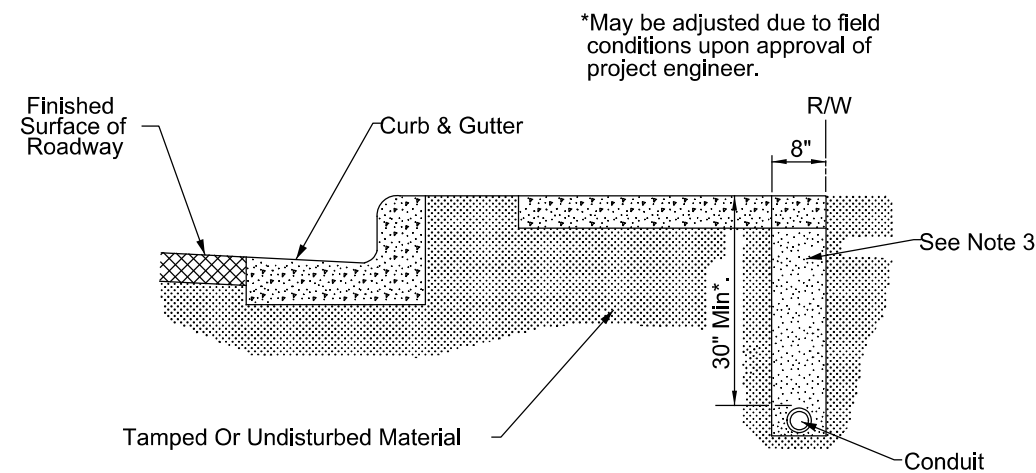

FOR USE IN INSTALLING CONDUIT UNDER SIDEWALK

FIGURE E

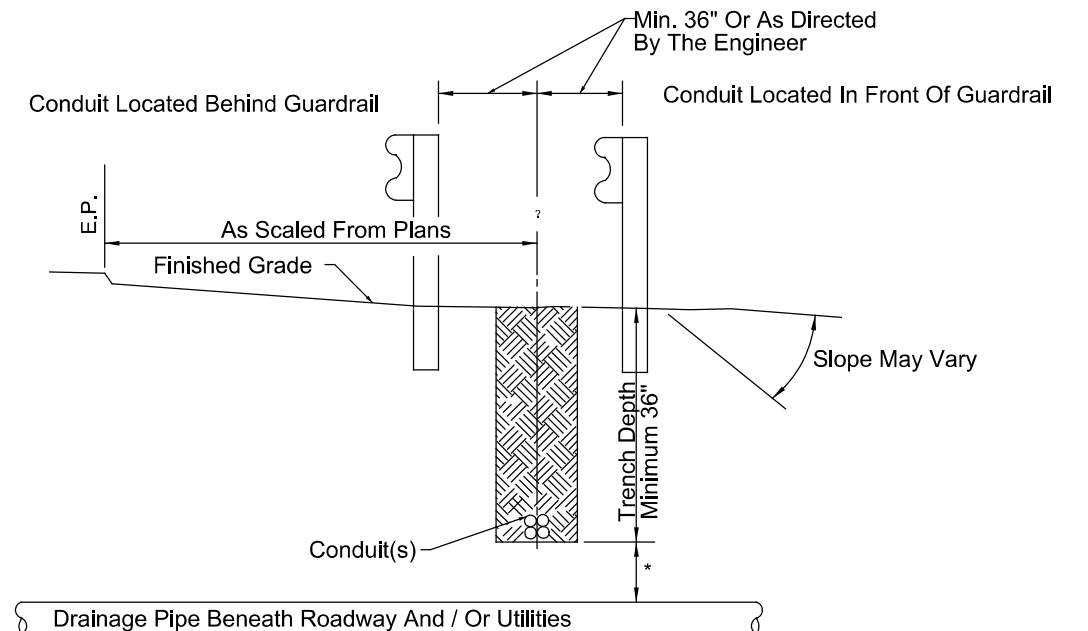

*Maintain 12" Minimum Vertical Clearance When Crossing Over Pipe And / Or Utilities. If Minimum Vertical Clearance Cannot Be Maintained, Then Conduit Is To Be Routed Under Pipe Maintaining 12" Minimum Vertical Clearance.

FIGURE F

LATEST REVISION

DESCRIPTION:

TRAFFIC CONTROL EQUIPMENT STANDARDS AND SPECIFICATIONS



DTPW TRAFFIC SIGNALS AND SIGNS DIVISION

7100 NW 36th STREET
MIAMI, FLORIDA 33166
305.592.3580

NAME	DATE
DRAWN BY: TRAVIS BREWER	12-09-16
CHECKED BY: NAHUM FERNANDEZ	03-22-17
APPROVED BY: FRANK AIRA, P.E.	

CONDUIT INSTALLATION DETAILS (N.T.S.)

SHEET NO.

1 of 2

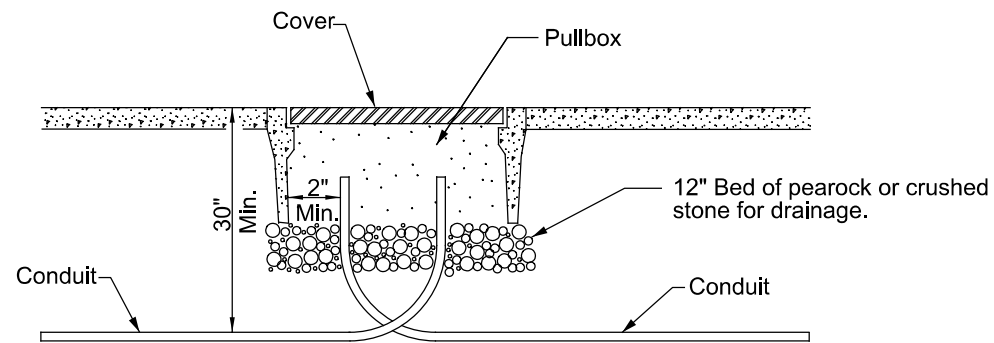

PULLBOX ENTRY OF CONDUIT UNDER SIDEWALKS

FIGURE G

Note:
Ends of conduit shall be sealed in accordance with Section 630 of the FDOT Standard Specifications for Road and Bridge Construction, and the Miami-Dade County Traffic Control Equipment Standards and Specifications.

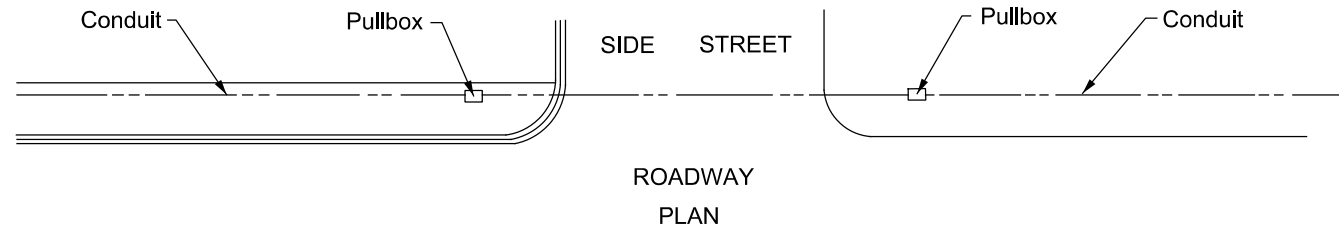

ROADWAY PLAN

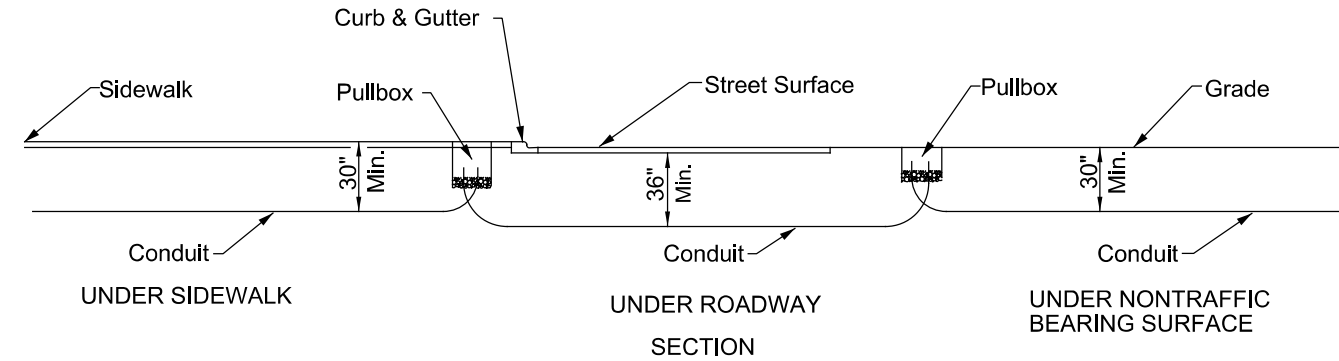

SECTION

FIGURE H

FIGURE I
FOR USE UNDER RAILROADS

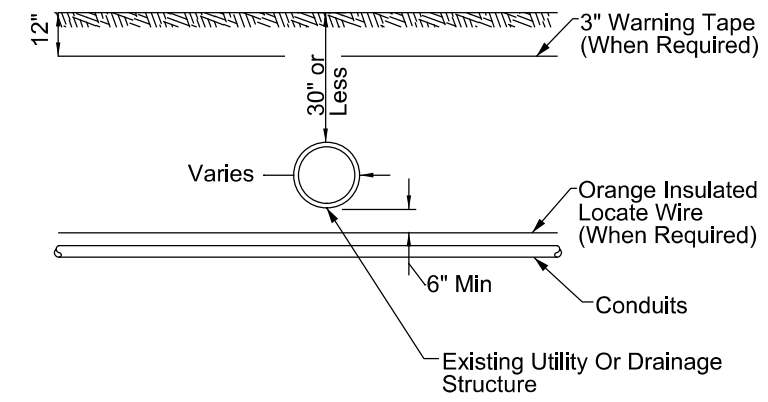
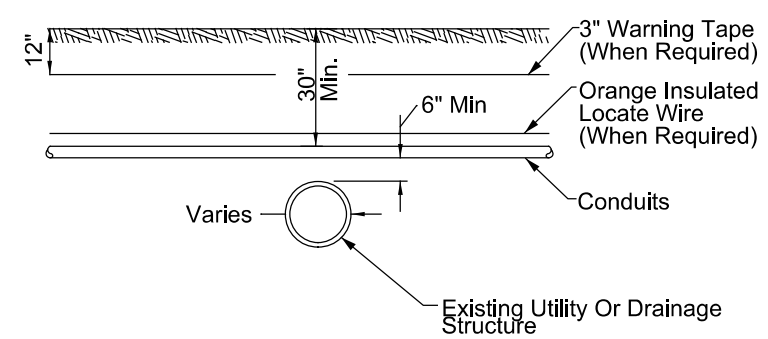
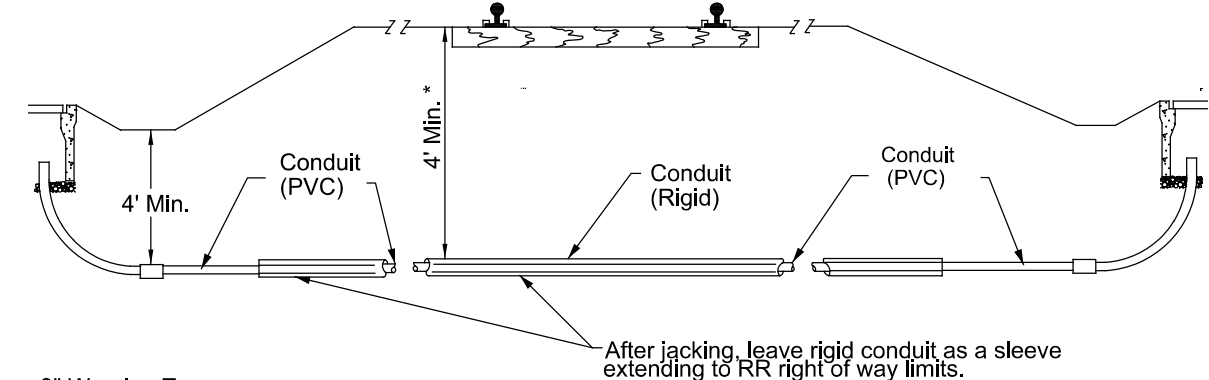

CONDUIT INSTALLATION DETAILS ACROSS EXISTING DRAIN PIPES OR UTILITIES

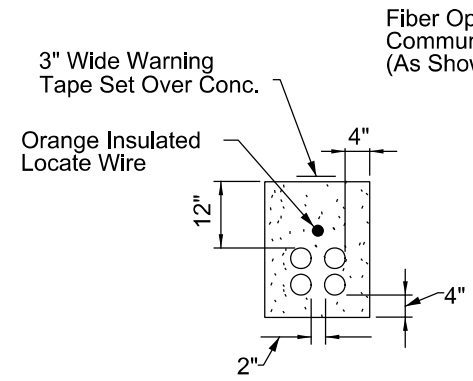
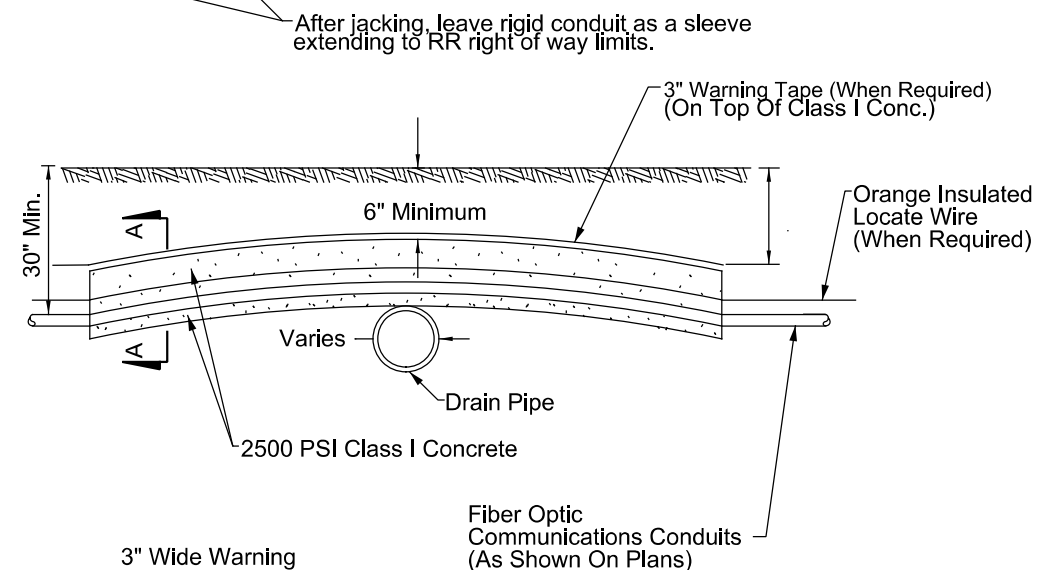

SECTION AA

GENERAL NOTES:

1. MEET THE REQUIREMENTS OF MIAMI-DADE COUNTY TRAFFIC CONTROL EQUIPMENT STANDARDS AND SPECIFICATIONS SECTION 630 (CONDUIT).
2. THE CONTRACTOR, WITH APPROVAL FROM THE ENGINEER, MAY ADJUST THE FINAL BURIAL DEPTH OF THE CONDUIT(S) IN ORDER TO TRANSVERSE NONMOVABLE OBJECT CONFLICTS.
3. BACKFILL WITH EXCAVATED MATERIAL AND COMPACT THE SOIL UNTIL FIRM AND UNYIELDING. REMOVE ROCK AND DEBRIS FROM BACKFILL MATERIAL.
4. WHERE CONDUITS ARE TO BE INSTALLED OVER EXISTING UNDERGROUND STRUCTURES (E.G., DRAIN PIPES OR UTILITY LINES) WHICH ARE LESS THAN 30" DEEP, THE CONTRACTOR SHALL ENCASE THE CONDUIT IN 2500 PSI CLASS I CONCRETE FOR THE ENTIRE LENGTH OF CONDUIT THAT IS INSTALLED AT A DEPTH OF LESS THAN 30".
5. IF THE AMOUNT OF COVER OVER THE ENCASEMENT IS LESS THAN 6", THE CONTRACTOR SHALL INSTALL THE CONDUIT TO PASS BELOW THE UNDERGROUND STRUCTURES (E.G., DRAIN PIPES).

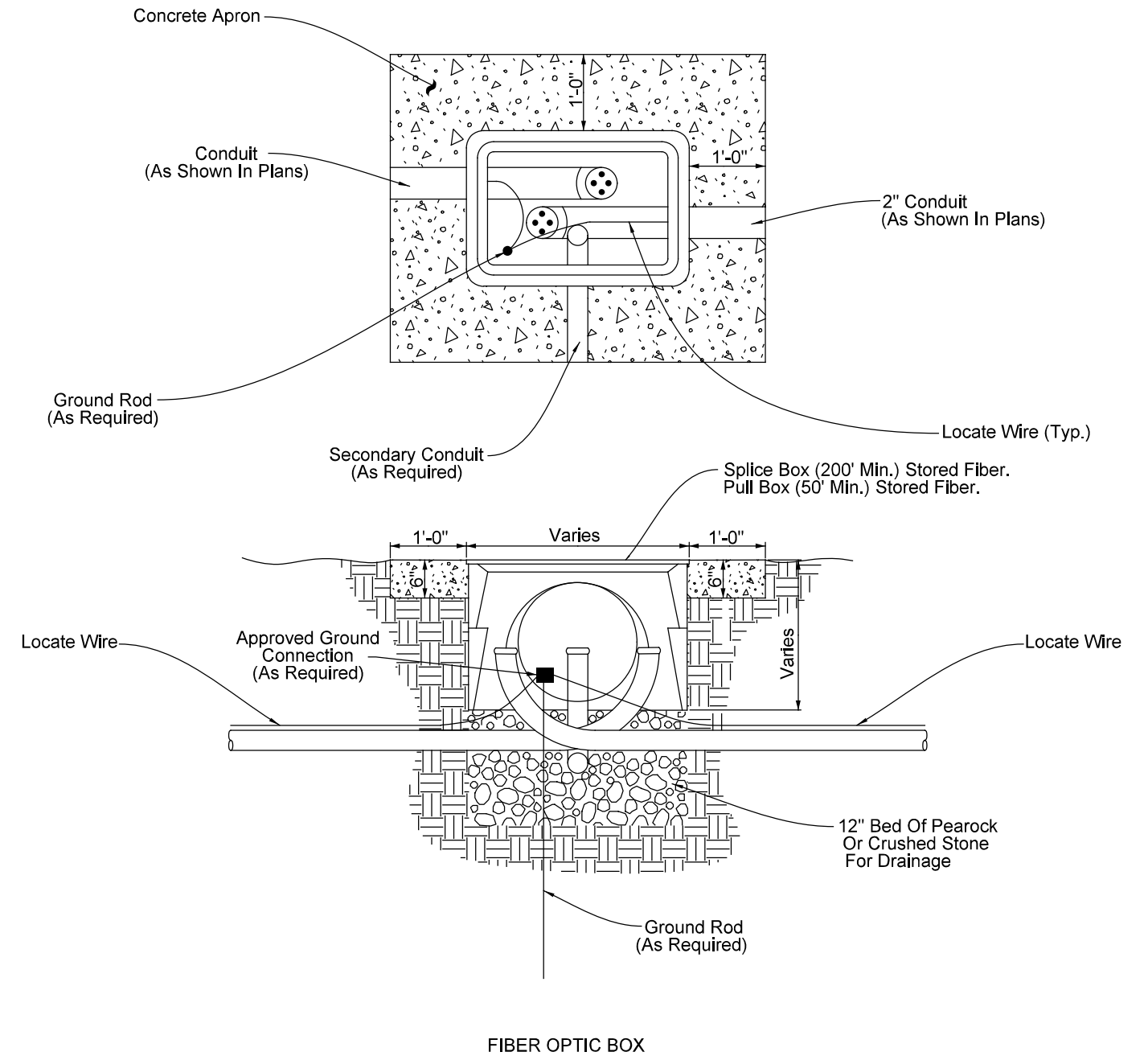
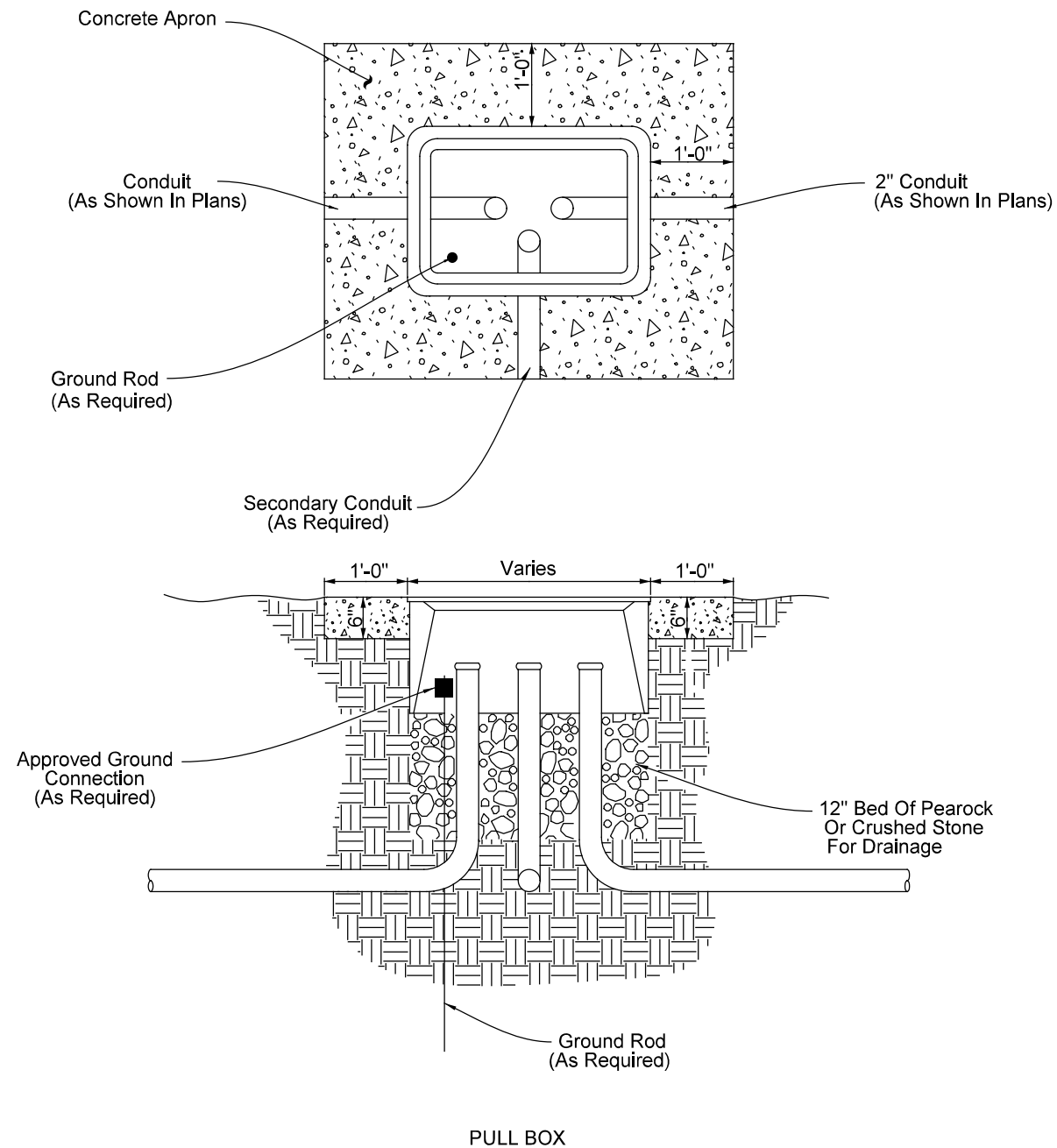

Rectangular boxes are depicted. Round fiber optic splice boxes and lids are allowed.

GENERAL NOTES:

1. MEET THE REQUIREMENTS OF MIAMI-DADE COUNTY TRAFFIC CONTROL EQUIPMENT STANDARDS AND SPECIFICATIONS SECTION 635 (PULL, SPLICE, AND JUNCTION BOXES)
2. BOXES SHALL NOT BE INSTALLED IN ROADWAYS OR DRIVEWAYS.
3. BOXES SHALL BE ON THE FDOT APPROVED PRODUCT LIST (APL) AND THE MIAMI-DADE COUNTY QUALIFIED PRODUCT LIST (QPL)
4. BOXES SHALL BE INSTALLED FLUSH WITH THE FINISHED GRADE SURFACE.
5. FIBER OPTIC SPLICE BOXES SHALL BE PROVIDED WITH CABLE HANGER RACKS DESIGNED TO SUPPORT CABLES AND SPLICE ENCLOSURES. COST OF RACKS TO BE INCLUDED IN COST OF SPLICE BOX.
6. FIBER OPTIC BOXES SHALL CONTAIN ONLY FIBER OPTIC CABLE, CONDUIT, AND LOCATE WIRE

7. CONDUIT CENTER LINE SHALL BE ALIGNED TO TOP EDGE OF BOX TO FACILITATE CABLE PULLING.
8. CONDUIT CENTER LINE SHALL BE ALIGNED TO TOP EDGE OF BOX TO FACILITATE CABLE PULLING.
9. ALL BOXES SHALL HAVE 1'-0" WIDE (MIN.) CONCRETE APRON. CONCRETE FOR CONCRETE APRONS SHALL BE CLASS NS WITH A MINIMUM STRENGTH AT 28 DAYS OF F'C=2.5 KSI. APRONS SHALL BE SLOPED AWAY FROM BOX. COST OF APRON TO BE INCLUDED IN THE COST OF EACH BOX.
10. PREVENT THE INGRESS OF WATER, DIRT, SAND, AND OTHER FOREIGN MATERIALS INTO THE CONDUIT PRIOR TO, DURING AND AFTER CONSTRUCTION USING A FOAM-SEALING MATERIAL, RUBBER PLUG, OR OTHER DEVICE DESIGNED FOR THIS APPLICATION.
11. WHERE MULTIPLE PULL BOXES ARE PLACED SIDE BY SIDE, MAINTAIN AT LEAST 8" BETWEEN THE PULL BOXES.

NOTES:

1. Critical Root Zone: Extends in all directions from trunk of tree to a distance equal to one foot per inch of trunk diameter at breast height.
2. Staging, storage, dumping, washing and operation of equipment is not permitted within the limits of the tree protection barrier, including during barrier installation.
3. Install all tree protection prior to commencement of construction and remove when directed by the Engineer. Maintain protection at all times.
4. For closely spaced groups of trees, place the tree protection barrier around the entire group.
5. Inspect trunk protection and tree quarterly to prevent girdling. Adjust bands to allow tree growth as needed.
6. See plans for any additional requirements or modifications within the tree protection area.
7. Place weather resistant sign every 50' along the barrier, with 6" minimum text height and provide text in English and Spanish. Sign should read "Keep Out Tree Protection Area".
8. Alternate tree protection systems approved by the Engineer may be used in lieu of the tree protection barrier detailed on this Index as long as the critical root zone is protected.
9. The Critical Root Zone may be reduced, in the field, by a certified Arborist or Landscape Architect.

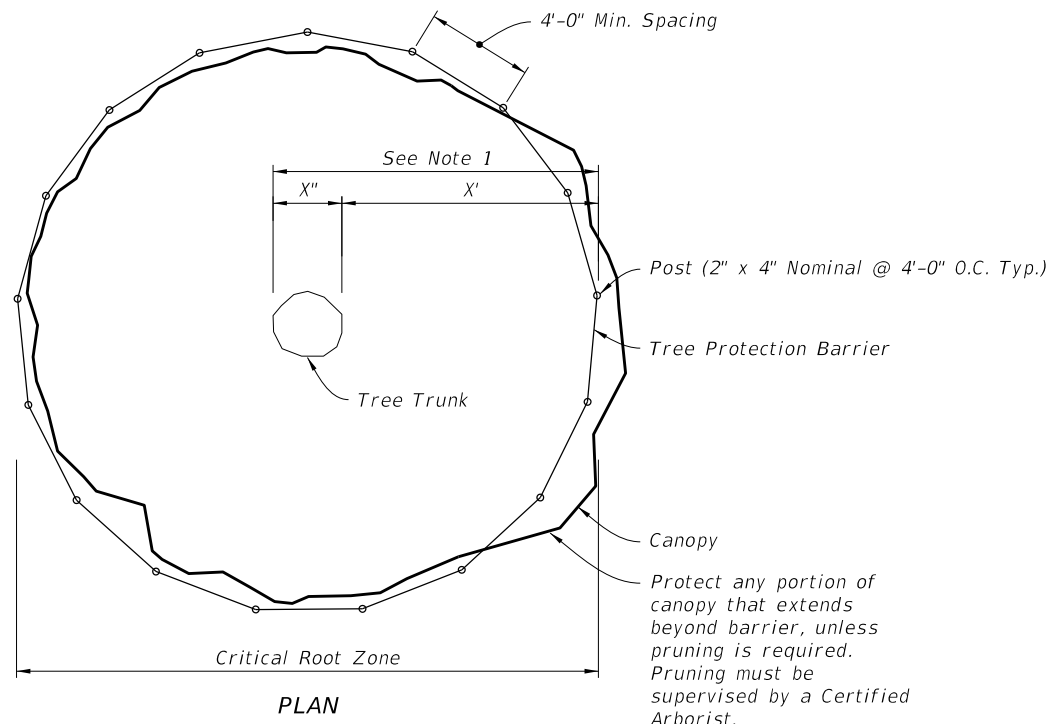

PLAN

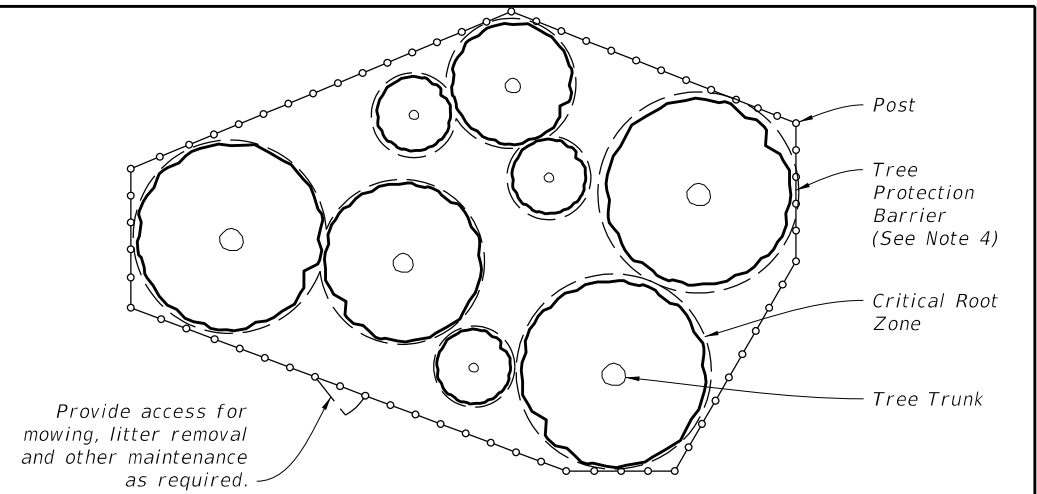

PLAN

PROTECTION BARRIER FOR TREE GROUPINGS

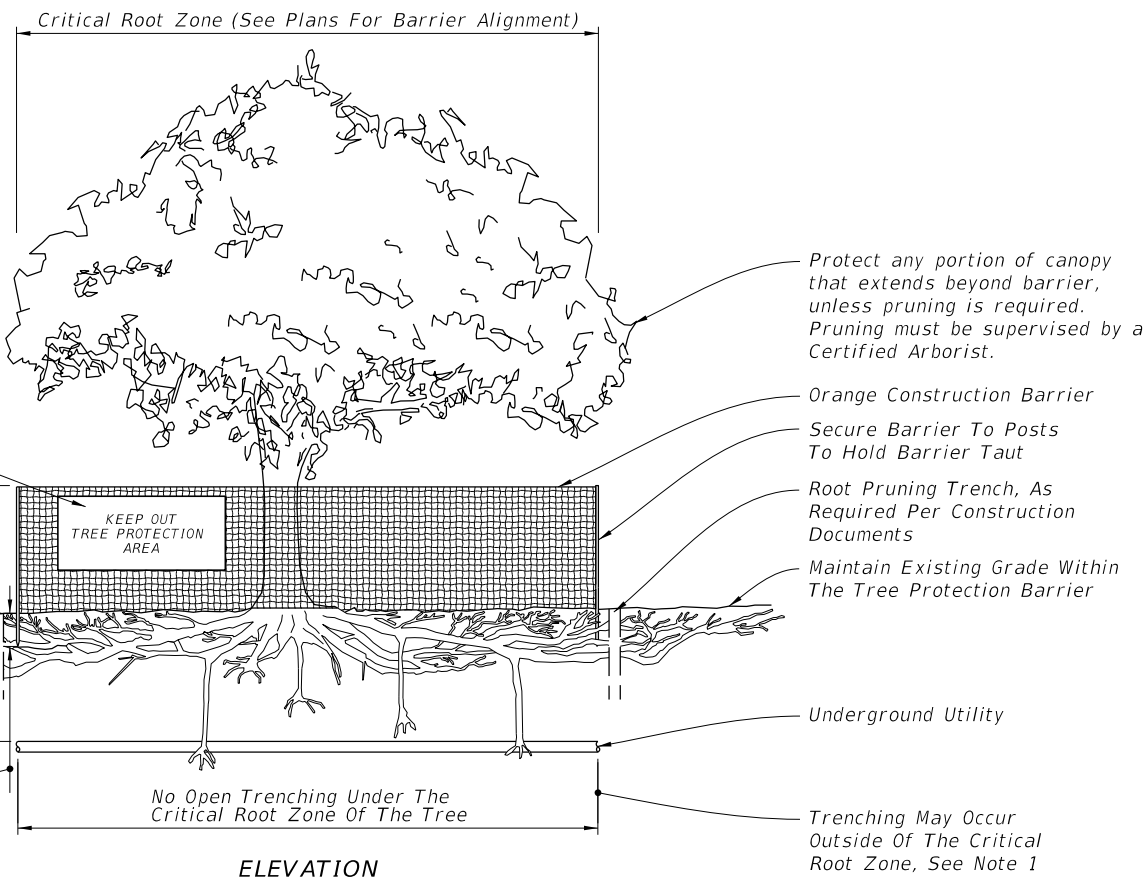

ELEVATION

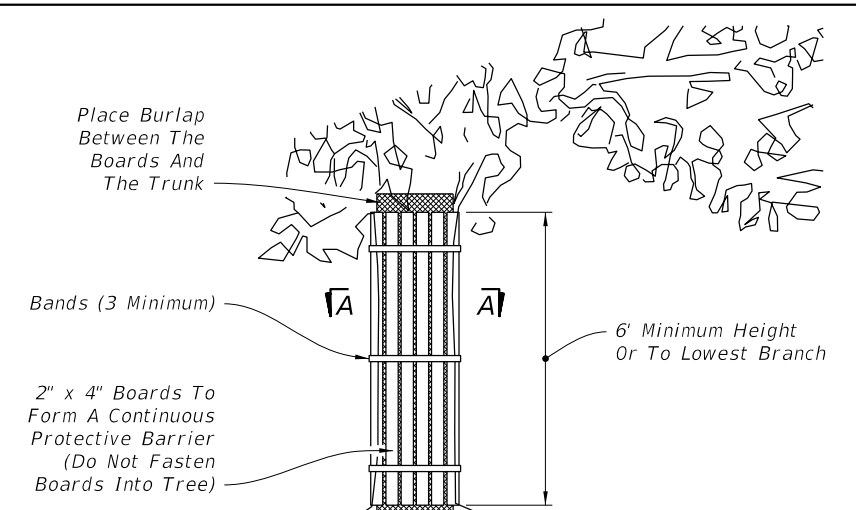

ELEVATION

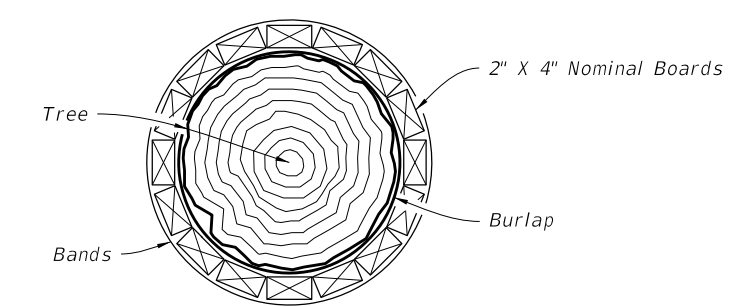

SECTION A-A

NOTES:

1. Trunk protection may be used when Tree Protection Barrier can not be reasonably erected, when approved by Engineer.
2. See Selective Clearing and Grubbing Plan for location of trunk protection, when applicable.
3. Adjust bands to allow tree growth (inspect quarterly to prevent girdling).

TRUNK PROTECTION

10/14/2019 8:55:19 AM

LAST REVISION 11/01/18	REVISION	DESCRIPTION:	 FY 2020-21 STANDARD PLANS	TREE PROTECTION AND PRESERVATION	INDEX 110-100	SHEET 1 of 1
---------------------------	----------	--------------	--	----------------------------------	------------------	-----------------