

## ELECTRONIC DOCUMENTS DISCLAIMER

1. Electronic copies of the solicitation documents are made available on this website solely for the convenience of prospective bidders (whether as a prime contractor or sub-contractor) on the Project, and are not considered part of the Contract Documents. No representation or warranty is made, either expressed or implied, with regard to the accuracy or suitability of these electronic copies for any purpose whatsoever. In the event of discrepancies or conflicts between the County's originally published document(s) and any other version distributed or submitted by other parties, the County's original hard copy version shall prevail.
2. Miami-Dade County Department of Transportation and Public Works (DTPW) does not track or monitor downloads of Project documents from this website. Therefore, prospective bidders who choose to use this method of distribution shall also be responsible for monitoring the site and downloading any applicable addenda or supplemental information. DTPW will distribute hard copy addenda or supplemental information only to those persons or firms who we have purchased a hard copy of the original solicitation documents.
3. Miami-Dade County shall not be responsible for errors and omissions occurring in the transmission or downloading of any documents or specifications from this website. In the event of any discrepancy between information obtained from this website and the DTPW hard copy solicitation documents and specifications, the terms of the hard copy documents will prevail.
4. Miami-Dade County does not guarantee continuous, uninterrupted or secure access to this or other related websites. Operation of this website may be affected from time to time by numerous factors outside of our control. In the event that we are notified of any problems in a timely manner we will do our best to assist with those problems that fall within our control. For assistance, contact us at 305-375-2930. Solicitation documents are removed from this website as soon as possible after the due date.
5. DTPW does not accept facsimile or electronic bid responses of any kind. All bids must be submitted in writing, on the forms provided by the County, to the address designated in the bid package. It is the bidder's responsibility to ensure that their submittals are received at the designated location, complete and on time. Bids received after the due date will be rejected, even if the solicitation is still appearing on this site.
6. With regards to Miscellaneous Construction Contracts (MCC) 7040 Plan Request for Price Quotations:
  - a. Only bidders included on the Project's Bidders List, provided by the Internal Service Department, Procurement Management Division to the DTPW, can submit a bid.
  - b. Only timely bids received from bidders included in the Project's Bidders List will be considered.
7. These documents shall not be altered in any manner. Utilization or viewing of these electronic documents shall constitute implicit acknowledgement and acceptance of these provisions. Failure to comply with these provisions may result in rejection of your bid.

Department of Transportation  
and Public Works



## Venetian Causeway Bridges Nos. 874459 and No.874474 Hurricane Irma Repairs

Miami-Dade County

Supplemental Solicitation  
and  
Contract Documents

**Small Business Enterprise-Construction Program (SBE-CONST.):**

10.65% Aspirational DBE Contract Goal

**Community Workforce Program:**

Not Applicable

**DTPW Capital Improvements Engineer:**

Elva Rosa Reyes.

**RPQ Issue Date:**

March 2, 2023

## TABLE OF CONTENTS

---

SECTION 1:	INVITATION TO BID
SECTION 2:	SOLICITATION FORMS
	BID FORM
	APPENDIX 5A
	ACKNOWLEDGEMENT OF ADDENDA
	SURETY BID BOND FORM
	DISADVANTAGED BUSINESS ENTERPRISE (DBE)-INFO
	CERTIFICATIN OF INCLUSION OF FHWA-1273
	CERTIFICATION REGARDING DEBARMENT, SUSPENSION, INELIGIBILITY AND VOLUNTARY EXCLUSION
	CERTIFICATION FOR DISCLOSURE OF LOBBYING ACTIVITIES ON FEDERAL-AID CONTRACTS
	DISCLOSURE OF LOBBYING ACTIVITIES
	NON-COLLUSION AFFIDAVIT
	AFFIRMATION OF VENDOR AFFIDAVITS
	FAIR WAGE AFFIDAVIT
	CONTRACTOR DUE DILIGENCE AFFIDAVIT
SECTION 3:	INSTRUCTION TO BIDDERS
	SUPPLEMENTARY INSTRUCTIONS TO BIDDERS
SECTION 4:	SUPPLEMENTAL INFORMATION
	SAMPLE SURETY PERFORMANCE AND PAYMENT BOND
SECTION 5:	SUPPLEMENTARY CONDITIONS
SECTION 6:	SPECIFICATIONS
	GENERAL REQUIREMENTS
	CONSTRUCTION SPECIFICATIONS
SECTION 7:	SPECIAL PROVISIONS
	TECHNICAL SPECIFICATIONS
SECTION 8:	ENGINEERING DRAWINGS

**SECTION 1: INVITATION TO BID**

# INVITATION TO BID

**Department of Transportation and  
Public Works**

**Capital Improvements Division  
111 NW 1st Street, Suite 1410  
Miami FL 33128**



**MIAMI-DADE COUNTY, FLORIDA**

**REQUEST FOR PRICE QUOTATION (RPQ)**

**Contract No: MCC 7360 Plan - CICC 7360-0/08**

**RPQ No: 20230004**

**INVITATION TO BID**

A RPQ has been issued for the work identified below. If you are interested in submitting a bid for this project, please submit your bid via Sealed Envelopes, attention to Clerk of the Board at 111 NW 1st Street, 17th floor, Miami Fl. 33128 no later than 4/5/2023 at 02:00 PM. If you have any questions, contact Elva Reyes at 305 375 2930.

This RPQ is issued under the terms and conditions of the Miscellaneous Construction Contracts (MCC) Program MCC 7360 Plan.

**RPQ DETAILED BREAKDOWN**

Bid Due Date:	4/5/2023	Time Due:	02:00 PM	Submitted Via:	Sealed Envelopes	SBE-Con. Level:	N/A
Estimated Value:	\$582,346 (excluding Contingencies and Dedicated Allowances)						
Project Name:	Venetian Causeway Bridges No. 874459 and No. 874474 - Hurricane Irma Repairs						
Project Location:	See the site location on the comments below						
License Requirements:	Primary:	General Engineering; Structural; FDOT Certificate of Qualification					
Scope of Work:	<p>(Contractor must obtain and submit all permits prior to performing any work).                  Work under this Contract includes furnishing of all supervision, labor, materials, tools, equipment and performing all operations required to construct the Work in accordance with the Contract Documents.                  Tasks to be performed includes, but is not limited to the following:</p> <ul style="list-style-type: none"> <li>• Remove components from the existing damaged timber fender system including, wales, spacer blocks, catwalk planks, deck supports, all associated connections and wire ropes, and install new wales, spacer blocks, catwalk planks, deck supports, wire ropes and handrail at both bridges.</li> <li>• Remove and replace fender navigational light system at both bridges.</li> <li>• Remove and replace existing damaged ladders platforms at both bridges.</li> <li>• Remove and replace existing damaged roof tiles at both bridge tender houses. Care to be taken not to allow any damaged tile to fall into water or adjacent sidewalk area. Damaged tile not eligible for repair to be disposed of in accordance with plans.</li> <li>• Remove and replace bitumen roof at the East Bridge Generator Building.</li> <li>• Repair spalls with exposed reinforcing as per specifications and plans at existing fender concrete piles, at both bridges.</li> <li>• Repair spalls with exposed reinforcing as per specifications and plans and repair concrete deck slab spalls at the East Bridge Generator Building.</li> <li>• Repair existing walls, clean and paint the exterior walls and steel gate at the East Bridge Generator Building.</li> </ul>						
Document Pickup:	Contact:	DTPW Capital Improvements Division	Phone No:	305 375-2930	Date:	3/2/2023	
	Location:	111 NW 1st. Street, Miami Florida 33128 Suite 1410					
Pre-Bid Meeting::	YES	Mandatory:	No	Date:	3/16/2023	Time:	10:00 AM
	Location:	Virtual PreBid Meeting-See notes below					
Site Meeting:	No	Mandatory:	No	Date:		Time:	
	Location:						
Bid shall be submitted to:	Contact:	Clerk of the Board					
	Address:	111 NW 1st Street, 17th floor, Miami Fl. 33128					
	Email:	valveo2@Miamiidade.gov	FAX # :				
Type of Contract:	Multiple Trade		Method of Award:	Lowest Responsible Bidder			
Method of Payment:	Scheduled Monthly Payments		Insurance Required:	YES			
Additional Insurance Required:	YES	If Yes - Minimum Coverage:		\$1,000,000.00			
Performance & Payment Bond Required:	YES		Bid Bond Required:		YES		
Prevailing Wage Rate Required:	Davis Bacon wages	Davis Bacon:	YES	Maintenance Wages:	NO	AIPP:	NO
		Amount:					
SBE-Con. Requirements:	NO	Percentage:	0.00%	SBD Certificate of Assurance Form Required:	NO		
DBE Participation:	YES	Percentage:	10.65%	DBE Subcontractor Forms Required:	NO		
CWP Requirements:	NO	Percentage:	0.00%				
SBE-S Requirements	NO	Percentage:	0.00%				
SBE-G Requirements	NO	Percentage:	0.00%				
Liquidated Damages:	YES	\$\$ Per Day:	\$1,699.00				
Trade Set-a-side:	NO	If Yes, Trade =					
For RPQ's less than \$10,000, if no LD rate is specified, the County reserves the right to assess actual damages in lieu of LDs.							
Design Drawing Included:	YES	Shop Drawing Included:	NO	Specifications Included:	YES		

Anticipated Start Date:	7/10/2023	Calendar Days for Project Completion:	330
Comments:	<p>A. The location of work to be performed under the terms of this Contract shall be as follows:</p> <p>1. Bridge No. 874459 (Venetian West Bascule) and Bridge No. 874474 (Venetian East Bascule) at the Fender System, Tender Houses and the East Bascule Generator House.</p> <p>B. The exact location and limits of construction are as shown on the Plans accompanying these Contract Documents.</p> <p>LICENSE REQUIREMENTS: At the time of Bid and pursuant to the requirements of Section 10-3 of the Code of Miami-Dade County, Florida and these Solicitation and Contract Documents, the Bidder must hold a valid, current, and active:</p> <p>a. At the time of Bid and pursuant to the requirements of Section 10-3 of the Code of Miami-Dade County, Florida and these Solicitation and Contract Documents, the Bidder must hold a valid, current, and active Certificate of Competency as a General Engineering Contractor or as a Specialty Engineering Contractor, commensurate to the requirements of the Project's Scope of Work, in one or more engineering crafts to include Structural Engineering. The Specialty Contractor shall subcontract with a qualified contractor any work which is incidental to the specialty but is specified in the aforementioned Code as being the work of other than that of the Engineering Specialty for which certified; or</p> <p>b. Pursuant to Section 255.20, Florida Statutes (F.S.) and in lieu of the above, the County may consider a bid from a Bidder that is a duly licensed Contractor in good standing that has been pre-qualified and considered eligible by the Florida Department of Transportation (FDOT) under Section 337.14, F.S. and Chapter 14-2, Florida Administrative Code, to perform the work described in the Contract Documents. Contractors seeking consideration under this paragraph shall submit along with the Bid Documents for review and consideration, current copy(ies) of their FDOT Certificate(s) of Qualification, Certification of Work Underway, and Status of Contract(s) On Hand. Acceptable FDOT prequalification(s) necessary to perform the work specified in the Project's Scope of Work shall include the Minor, or Major bridge Work Class.</p> <p>EXPERIENCE:</p> <p>1. The Bidder must demonstrate that it has full-time personnel with the necessary experience to perform the Project's Scope of Work. This experience shall include work in successfully completed projects performed by the identified personnel whose bulk of work performed in the Public Right-of-Way is similar in detail to the Project's Scope of Work described in these Solicitation Documents. Demonstrate the experience requirement by:</p> <p>a. Providing a detailed description of at least three (3) projects similar in detail to the Project's Scope of Work described in these Solicitation Documents and in which the Bidder's identified personnel is currently engaged or has completed within the past five years. List and describe the aforementioned projects and state whether the work was performed for the County, other government clients, or private entities. The description must identify for each project:</p> <ol style="list-style-type: none"> <li>1) The identified personnel and their assigned role and responsibilities for the listed project</li> <li>2) The client name and address including a contact person and phone number for reference</li> <li>3) Description of work</li> <li>4) Total dollar value of the contract</li> <li>5) Contract duration</li> <li>6) Statement or notation of whether Bidder's referenced personnel is/was employed by the prime contractor or subcontractor, and</li> <li>7) For completed projects, provide letters of certification of final acceptance or similar project closure documentation issued by the client and available Contractor's performance evaluations.</li> </ol> <p>2. The County reserves the right to request additional information and/or contact listed persons pertaining to bidder's experience.</p> <p>INDEMNIFICATION AND INSURANCE REQUIREMENTS The Contractor shall furnish to Department of Transportation and Public Works, 111 NW 1 Street, Miami Florida 33128, Certificate(s) of Insurance which indicate that insurance coverage has been obtained which meets the requirements as outlined below:</p> <ol style="list-style-type: none"> <li>1. Worker's Compensation Insurance for all employees of the Contractor as required by Florida Statute 440. As applicable should include coverage required under the U.S. Longshoremen and Harbor Workers' Act (USL&amp;H) and/or Jones Act for any activities on or about navigable water.</li> <li>2. Commercial General Liability Insurance in an amount not less than \$1,000,000 per occurrence, and \$2,000,000 in the aggregate, not to exclude Products &amp; Completed Operations. Miami-Dade County shall be included as additional insured.</li> <li>3. Automobile Liability Insurance covering all owned, non-owned and hired vehicles used in connection with the work, in an amount not less than \$1,000,000 combined single limit per occurrence for bodily injury and property damage. In addition to the insurance coverages listed above the Contractor and/or sub-contractor that owns the barge(s) and/or vessel(s) must provide the following insurance coverage: <ol style="list-style-type: none"> <li>1. Protection and Indemnity Insurance in the name of the vessel owner, in an amount not less</li> </ol> </li> </ol>		

than \$1,000,000 per occurrence. Miami-Dade County must be shown as an additional insured with respect to this coverage.

**BID DOCUMENTS:**

Bidding documents may be purchased from the Miami-Dade County Department of Transportation and Public Works, Capital Improvements Division, 111 NW 1st Street, 14th Floor, Miami, Florida 33128 for a non-refundable fee of One Hundred and Fifty Dollars (\$150.00) per each complete set of documents. Payment shall be in the form of a company check, cashier's check, or money order payable to the "Miami-Dade County, Department of Transportation and Public Works".

**ADDENDUMS - RFI'S**

All RFI requests should be e-mailed to reyesel@miamidade.gov while copying the Clerk of the Board (clerkbcc@miamidade.gov).

The Department of Transportation and Public Works has made changes with regard to how addendums and requests for information (RFI) will be sent to document holders. Be advised that all Addendums, RFI's, and the document holders list (bidder's list) are now available to view online at the following web address:

<https://www8.miamidade.gov/Apps/ISD/DPMWW/SolicitationList.aspx>

Therefore, during the advertisement period, the Department will not be sending these documents via certified mail. All document holders must provide a dedicated e-mail address. The Department will only be sending addendums and RFIs by e-mail and posting online at the aforementioned link. The bidders list will be updated every Friday during the advertisement phase of the contract. Please be aware that acknowledgment of receipt of all addendums and RFI's remain a requirement when submitting bids.

**VENDOR REGISTRATION:**

Due to the new Vendor Registration procedures of the Internal Service Department, Procurement Management Division, updated definitions along with the "Affirmation of Vendor Affidavits" has been added to the Bid Submittal Package. The successful bidder must be registered under this new procedure prior to award.

**PRE BID - BID SUBMITTAL DUE DATE:**

Pre-Bid Conference date, time and location: Thursday, March 16, 2023, at 10:00 A.M., Non-Mandatory Pre Bid Meeting will be conducted via teleconference in Microsoft Teams. Those interested in attending, please use the telephone number and access code below:

Telephone No. 1 786 628 2782  
Phone Conference ID: 155 232 592 #

**Bid Due Date, Opening Time & Location:**

Bid Submittal Time and Location: Wednesday, April 5, 2023, 2:00 PM, at 111 NW 1st Street, 17th Floor, Clerk of the Board Office.

Bid Opening immediately after in the 18 Floor. Due to the COVID-19 Pandemic, please always confirm the day before in the event there are any new orders issued by Miami Dade County Mayor.



## **SECTION 2: SOLICITATION FORMS**

All forms and documents contained in this Section shall be completed pursuant to these Contract Documents and submitted with the Bid Submittal for this Project.

# BID FORM

# Bid Form

**PROJECT TITLE:** Venetian Causeway Bridges No. 874459 and No. 874474-Hurricane Irma Repairs

**PROJECT NO:** 20230004

IF THIS PROPOSAL IS ACCEPTED, THE UNDERSIGNED AGREES TO COMPLETE ALL WORK UNDER THIS CONTRACT WITHIN THREE HUNDRED THIRTY (330) CALENDAR DAYS AFTER THE EFFECTIVE DATE ESTABLISHED IN THE \*NOTICE TO PROCEED WITH CONTRACT WORK\*.

Item No	Quantity	Unit	Description	Written Unit Amount	Unit Price	Total
101-1-A	1.0	L.S.	Mobilization			
102-1A	1.0	L.S.	MAINTENANCE OF TRAFFIC			
104-11A	2,000.0	L.F.	FLOATING TURBIDITY BARRIER			
110-82	9.6	MB	Remove & Dispose Structural Timber			
401-70-2	32.2	CF	Restore Spalled Areas, Latex Modified Mortar-Styrene Butadiene			
455-76	5.0	EA	Wrap Pile Clusters			
460-6-1	1.0	L.S.	LADDERS & PLATFORMS, NEW			
470-1	16.8	MB	TREATED TIMBER, Structural			
510-1	1.0	L.S.	Navigation Lights - Fixed Bridge, System			
510-1-2	1.0	L.S.	Electrical System (Removal) (Existing Fixed Bridge Navigational Lights)			
750-1-59	637.0	S.F.	Architectural-Building, Rehab			
751-7	1.0	L.S.	Architectural Roof Repair/Replacement			

# Bid Form

**PROJECT TITLE:** Venetian Causeway Bridges No. 874459 and No. 874474-Hurricane Irma Repairs

**PROJECT NO:** 20230004

IF THIS PROPOSAL IS ACCEPTED, THE UNDERSIGNED AGREES TO COMPLETE ALL WORK UNDER THIS CONTRACT WITHIN THREE HUNDRED THIRTY (330) CALENDAR DAYS AFTER THE EFFECTIVE DATE ESTABLISHED IN THE \*NOTICE TO PROCEED WITH CONTRACT WORK\*.

**Total:** \_\_\_\_\_

The bidder understands and agrees that the above total is inclusive of all work necessary to complete the job as described in the plans and specifications.

Quantities are established and are included only for the purpose of facilitating the uniform comparison of bids submitted. The County shall not be held responsible if the quantities are not accurate and all computations for compensation shall be based upon the actual work performed, whether greater or less than estimated quantities.

Tax Identification Number: \_\_\_\_\_

D.C. Certificate of competency No: \_\_\_\_\_

Bidder's Name: \_\_\_\_\_

Bidder's telephone Number: \_\_\_\_\_

Bidder's address: \_\_\_\_\_

# Bid Form

**PROJECT TITLE:** Venetian Causeway Bridges No. 874459 and No. 874474-Hurricane Irma Repairs

**PROJECT NO:** 20230004

IF THIS PROPOSAL IS ACCEPTED, THE UNDERSIGNED AGREES TO COMPLETE ALL WORK UNDER THIS CONTRACT WITHIN THREE HUNDRED THIRTY (330) CALENDAR DAYS AFTER THE EFFECTIVE DATE ESTABLISHED IN THE \*NOTICE TO PROCEED WITH CONTRACT WORK\*.

BIDDER ACKNOWLEDGES THAT INCLUDED IN THE VARIOUS ITEMS OF THE PROPOSAL AND IN THE TOTAL BID PRICE ARE COSTS FOR COMPLYING WITH THE FLORIDA TRENCH SAFETY ACT (90-96), LAWS OF FLA. EFFECTIVE OCTOBER 1st, 1990. THE BIDDER FURTHER IDENTIFIES THE COSTS TO BE SUMMARIZED BELOW:

	Trench Safety Measure (Description)	Units of Measure (LF, SY)	Unit (Quantity)	Unit Cost	Extended Cost
A.	_____	_____	_____	_____	_____
B.	_____	_____	_____	_____	_____
C.	_____	_____	_____	_____	_____
D.	_____	_____	_____	_____	_____

FAILURE TO COMPLETE THE ABOVE MAY RESULT IN THE BID BEING DECLARED NON-RESPONSIVE

ATTACHMENT 5A

Department of  
Transportation and Public  
Works  
Capital Improvements Division  
111 NW 1st Street, Suite 1410  
Miami FL 33128,



MIAMI-DADE COUNTY, FLORIDA  
REQUEST FOR PRICE QUOTATION (RPQ)  
Contract No: MCC 7360 Plan - CICC 7360-0/08  
RPQ No: 20230004

**RPQ BID FORM – ATTACHMENT 5A**

---

**RPQ Project Name:** Venetian Causeway Bridges No. 874459 and No. 874474 - Hurricane Irma Repairs

---

**Price Proposal** (Cost to Perform the work **must** be stated here. State 'No Bid' if not submitting a price proposal)

---

**Bidder's Company Name:** \_\_\_\_\_

**Company Address:** \_\_\_\_\_

**City:** \_\_\_\_\_ **State:** \_\_\_\_\_ **Zip:** \_\_\_\_\_

**Telephone No:** \_\_\_\_\_ **Fax No:** \_\_\_\_\_ **E-Mail:** \_\_\_\_\_

THE EXECUTION OF THIS FORM CONSTITUTES THE UNEQUIVOCAL OFFER OF PROPOSER TO BE BOUND BY THE TERMS OF ITS PROPOSAL. FAILURE TO SIGN THIS SOLICITATION WHERE INDICATED BELOW BY AN AUTHORIZED REPRESENTATIVE SHALL RENDER THE PROPOSAL NON-RESPONSIVE. THE COUNTY MAY, HOWEVER, IN ITS SOLE DISCRETION, ACCEPT ANY PROPOSAL THAT INCLUDES AN EXECUTED DOCUMENT WHICH UNEQUIVOCALLY BINDS THE PROPOSER TO THE TERMS OF ITS OFFER.

**Name of Person Submitting Quote (Print):** \_\_\_\_\_

**Number of Addendums received:** \_\_\_\_\_ (if none' write "None")

**Signature:** \_\_\_\_\_

**Date:** \_\_\_\_\_

---

Note: Quotes must be submitted on this form. Quote envelope must state RPQ Number, date and time due and the Bidder's Name. Use of any other form for submission of the price quotation shall result in the rejection of the price quotation. Late bids will not be opened. *Low bidder will be notified, in the Recommendation of Award, of the requirements to submit current copies of insurance certificates in accordance with the Contract Documents. By signature, the CONTRACTOR agrees to be bound by the terms set forth in the MCC 7360 Plan.*

## ACKNOWLEDGEMENT OF ADDENDA



MIAMI-DADE COUNTY  
DEPARTMENT OF TRANSPORTATION AND PUBLIC WORKS (DTPW)

---

PROJECT: Venetian Causeway Bridges No. 874459 and No. 874474 – Hurricane Irma Repairs  
Project No. 20230004

**ACKNOWLEDGEMENT OF ADDENDA**

(Must be completed and submitted with required solicitation documents)

**Instructions:** Complete Part I or Part II, as applicable.

---

**PART I:** Listed below are the dates of issue for each Addendum received in connection with this solicitation.

Addendum #1, Dated _____,	202__
Addendum #2, Dated _____,	202__
Addendum #3, Dated _____,	202__
Addendum #4, Dated _____,	202__
Addendum #5, Dated _____,	202__
Addendum #6, Dated _____,	202__
Addendum #7, Dated _____,	202__
Addendum #8, Dated _____,	202__
Addendum #9, Dated _____,	202__
Addendum #10, Dated _____,	202__

---

**PART II:**

\_\_\_\_ No Addendum was received in connection with this solicitation.

---

Authorized Signature: \_\_\_\_\_ Date: \_\_\_\_\_

Print Name: \_\_\_\_\_ Title: \_\_\_\_\_

Firm Name: \_\_\_\_\_

# SURETY BID BOND FORM

<b>SURETY BID BOND</b>	DATE BOND EXECUTED (must not be later than bid opening date)	REV. 0216 DTPW
------------------------	--	-------------------

PRINCIPAL (Full legal name and business address)	TYPE OF ORGANIZATION ("X" one)	
	<input type="checkbox"/> Individual	<input type="checkbox"/> Partnership
	<input type="checkbox"/> Joint Venture	<input type="checkbox"/> Corporation

SURETY (Name and business address)

PENAL SUM OF BOND	*****Five Percent of the Total amount Bid*****		
-------------------	--	--	--

BID IDENTIFICATION	Project No:	20230004	Bid Opening Date:	
	County Project Name	Venetian Causeway Bridges No. 874459 and No. 874474 - Hurricane Irma Repairs		

**OBLIGATION**

Principal and Surety, jointly and severally, bind themselves, their heirs, executors, administrators, successors, and assigns to pay to Miami-Dade County, Florida (herein after County) upon default of Principal the penal sum set forth on the face of this Bond.

Principal and Surety agree that the Penal Sum of the Bond is a liquidated damage reasonably estimated to compensate the County for damages suffered as a result of the Principal's default including but not limited to any resulting from delay, reprocurement costs and incremental costs of contracting.

Default of Principal shall occur in the event that the Principal withdraws Bid within 180 days after bid opening (or any extension thereof agreed to in writing by the Bidder and County); or, after proper notification of intent to Contract from the County, fails to comply with all pre-award requirements including, but not limited to providing Payment and Performance Bonds with good and sufficient surety and the necessary Insurance Certificates pursuant to the Contract Documents, and enter into a written Contract with the County, as may be required; all within 10 days after the prescribed forms are presented to Principal for signature or as otherwise required by the Bidding Documents.

Payment under this Bond will be due and payable upon default of Principal and within 30 calendar days after receipt by Principal and Surety of written notice of default from County, which notice will be given with reasonable promptness, identifying this Bond and the Project.

Surety shall cause to be attached to this Bond a current and effective Power of Attorney evidencing the authority of the officer, agent, or representative who executed this Bond on behalf of Surety to execute, seal, and deliver such Bond and bind the Surety thereby.

**CONDITIONS**

The Principal has submitted the Bid identified above.

**THEREFORE**

By executing this instrument Surety agrees that its obligation is not impaired by any extension(s) of the time for acceptance of the bid that the Principal may grant to the County. Notice to the Surety of extensions is waived. However, waiver of the notice applies only to extensions aggregating not more than 60 calendar days in addition to the period originally allowed for acceptance of the bid. Any changes in or under the Contract Documents and compliance or noncompliance with any formalities connected with the Contract or the changes does not affect Surety's obligation under this Bond.

**WITNESS**

The Principal and Surety executed this Bond and affixed their seals on the above date. Copy of Authorized Agent's current Identification Card as issued by State of Florida Insurance Commissioner must be attached.

**PRINCIPAL**

SIGNATURE		Principal's Corporate Seal
NAME AND TITLE (Typed)		

**SURETY**

SIGNATURE OF ATTORNEY-IN-FACT		Surety's Corporate Seal
PRINTED NAME OF ATTORNEY-IN-FACT (Typed)		
SIGNATURE OF AUTHORIZED FLORIDA AGENT		
PRINTED NAME OF AUTHORIZED FLORIDA AGENT (Typed)		

DISADVANTAGED BUSINESS ENTREPRISE (DBE)  
PACKAGE INFORMATION

### **DBE Utilization**

The Department began its DBE race neutral program January 1, 2000. **Contract specific goals are not placed on Federal/State contracts;** however, the Department has an overall 10.65% DBE goal it must achieve. In order to assist contractors in determining their DBE commitment level, the Department has reviewed the estimates for this letting.

As you prepare your bid, please monitor potential or anticipated DBE utilization for contracts. When the low bidder executes the contract with the Department, information will be requested of the contractor's DBE participation for the project. While the utilization is not mandatory in order to be awarded the project, continuing utilization of DBE firms on contracts supports the success of Florida's DBE Program, and supports contractors' Equal Employment Opportunity and DBE Affirmative Action Programs.

Any project listed as 0% DBE availability does not mean that a DBE may not be used on that project. A 0% DBE availability may have been established due to any of the following reasons: limited identified subcontracting opportunities, minimal contract days, and/or small contract dollar amount. Contractors are encouraged to identify any opportunities to subcontract to DBE's.

Please contact the Equal Opportunity Office at (850) 414-4747 if you have any questions regarding this information.

### **DBE Reporting**

If you are the prime contractor on a project, enter your DBE participation in the Equal Opportunity Compliance system prior to the pre-construction or pre-work conference for all federal and state funded projects. This **will not** become a mandatory part of the contract. It will assist the Department in tracking and reporting planned or estimated DBE utilization. During the contract, the prime contractor is required to report actual payments to DBE and MBE subcontractors through the web-based Equal Opportunity Compliance (EOC) system.

All DBE payments must be reported whether or not you initially planned to utilize the company. In order for our race neutral DBE Program to be successful, your cooperation is imperative. If you have any questions, please contact [EOOHelp@dot.state.fl.us](mailto:EOOHelp@dot.state.fl.us).

### **Bid Opportunity List**

The Federal DBE Program requires States to maintain a database of all firms that are participating or attempting to participate on FDOT-assisted contracts. The list must include all firms that bid on prime contracts or bid or quote subcontracts on FDOT-assisted projects, including both **DBE's and non-DBEs**.

Please complete the Bidders Opportunity List through the Equal Opportunity Compliance system within 3 business days of submission of the bid or proposal for ALL subcontractors or sub-consultants who quoted to you for specific project for this letting. The web address to the Equal Opportunity Compliance system is: <https://www.fdot.gov/equalopportunity/eoc.shtml>.

### **DBE/AA Plans**

Contractors bidding on FDOT contracts are to have an approved DBE Affirmative Action Plan (FDOT Form 275-030-11B) on file with the FDOT Equal Opportunity Office before execution of a contract. DBE/AA Plans must be received with the contractors bid or received by the Equal Opportunity Office prior to the award of the contract.

Plans are approved by the Equal Opportunity Office in accordance with Ch. 14-78, Florida Administrative Code. Plans that do not meet these mandatory requirements may not be approved. Approvals are for a (3) three year period and should be updated at anytime there is a change in the company's DBE Liaison Officer and/or President. Contractors may evidence adoption of the DBE/AA Policy and Plan and/or a change in the designated DBE Liaison officer as follows:

- Print the first page of the document on company stationery ("letterhead") that indicates the company's name, mailing address, phone number, etc.
- Print the company's name in the "\_\_\_\_" space; next to "Date" print the month/day/year the policy is being signed; record the signature of the company's Chief Executive Officer, President or Chairperson in the space next to "by" and print the full first and last name and position title of the official signing the policy.
- Print the DBE Liaison's full name, email address, business mailing address and phone number the bottom of email.

E-mail the completed and signed DBE AA Plan to: **eeoforms@dot.state.fl.us**.

The Department will review the policy, update department records and issue a notification of approval or disapproval; a copy of the submitted plan will not be returned to the contractor.

STATE OF FLORIDA DEPARTMENT OF TRANSPORTATION  
**BID OPPORTUNITY LIST FOR PROFESSIONAL CONSULTANT  
SERVICES, AND COMMODITIES & CONTRACTUAL SERVICES**

375-040-62  
PROCUREMENT  
04/07

Prime Contractor/Prime Consultant: \_\_\_\_\_

Address/Phone Number: \_\_\_\_\_

Procurement Number/Advertisement Number: \_\_\_\_\_

49 CFR Part 26.11 The list is intended to be a listing of all firms that are participating, or attempting to participate, on DOT-assisted contracts. The list must include all firms that bid on prime contracts, or bid or quote subcontracts and supplies materials on DOT-assisted projects, including both DBEs and non-DBEs. For consulting companies this list must include all subconsultants contacting you and expressing an interest in teaming with you on a specific DOT-assisted project. Prime contractors and consultants must provide information for Numbers 1, 2, 3 and 4, and should provide any information they have available on Numbers 5, 6, 7, and 8 for themselves, and their subcontractors and subconsultants.

1. Federal Tax ID Number: \_\_\_\_\_  
2. Firm Name: \_\_\_\_\_  
3. Phone: \_\_\_\_\_  
4. Address: \_\_\_\_\_  
\_\_\_\_\_  
\_\_\_\_\_  
5. Year Firm Established: \_\_\_\_\_

6.  DBE  
 Non-DBE  
7.  Subcontractor  
 Subconsultant

8. Annual Gross Receipts  
 Less than \$1 million  
 Between \$1 - \$5 million  
 Between \$5 - \$10 million  
 Between \$10 - \$15 million  
 More than \$15 million

1. Federal Tax ID Number: \_\_\_\_\_  
2. Firm Name: \_\_\_\_\_  
3. Phone: \_\_\_\_\_  
4. Address: \_\_\_\_\_  
\_\_\_\_\_  
\_\_\_\_\_  
5. Year Firm Established: \_\_\_\_\_

6.  DBE  
 Non-DBE  
7.  Subcontractor  
 Subconsultant

8. Annual Gross Receipts  
 Less than \$1 million  
 Between \$1 - \$5 million  
 Between \$5 - \$10 million  
 Between \$10 - \$15 million  
 More than \$15 million

1. Federal Tax ID Number: \_\_\_\_\_  
2. Firm Name: \_\_\_\_\_  
3. Phone: \_\_\_\_\_  
4. Address: \_\_\_\_\_  
\_\_\_\_\_  
\_\_\_\_\_  
5. Year Firm Established: \_\_\_\_\_

6.  DBE  
 Non-DBE  
7.  Subcontractor  
 Subconsultant

8. Annual Gross Receipts  
 Less than \$1 million  
 Between \$1 - \$5 million  
 Between \$5 - \$10 million  
 Between \$10 - \$15 million  
 More than \$15 million

1. Federal Tax ID Number: \_\_\_\_\_  
2. Firm Name: \_\_\_\_\_  
3. Phone: \_\_\_\_\_  
4. Address: \_\_\_\_\_  
\_\_\_\_\_  
\_\_\_\_\_  
5. Year Firm Established: \_\_\_\_\_

6.  DBE  
 Non-DBE  
7.  Subcontractor  
 Subconsultant

8. Annual Gross Receipts  
 Less than \$1 million  
 Between \$1 - \$5 million  
 Between \$5 - \$10 million  
 Between \$10 - \$15 million  
 More than \$15 million

**AS APPLICABLE, PLEASE SUBMIT THIS FORM WITH YOUR:**

**BID SHEET (Invitation to Bid – ITB)  
LETTERS OF RESPONSE (LOR)  
PRICE PROPOSAL (Request for Proposal – RFP)  
REPLY (Invitation to Negotiate – ITN)**

CERTIFICATION OF INCLUSION OF FHWA-1273



# Certification of Inclusion of FHWA-1273

<b>Project Identification</b>		
1. Project No.	2. FDOT Financial Project No.	3. Project Location
4. Prime Contractor's Name		5. FEID Number
<b>Prime Contractor Certification</b>		
<p>I certify by my signature below that I have included in the contract with the Sub-Contractor, Supplier, or Rental Company identified below, a complete and unaltered copy of FHWA-1273 (Required Contract Provisions Federal-Aid Construction Contracts), and further require inclusion of the same in every lower tier subcontract or purchase order that may be made in turn. I hereby acknowledge my responsibility for ensuring compliance by any subcontractor or lower tier subcontractor with these Required Contract Provisions.</p>		
6. Name (first/last) of Corporate Official signing Certification		7. Title
8. Signature of Certifying Official		9. Date of Signature
<b>Sub-Contractor, Supplier, or Rental Company Certification</b>		
<p>I certify by my signature below that I have received a complete and unaltered copy of FHWA-1273 (Required Contract Provisions Federal-Aid Construction Contracts), will comply with all requirements stipulated therein, and will require inclusion of the same in every lower tier subcontract or purchase order that may be made in turn.</p>		
10. Tier Level		
11. Name of Sub-Contractor, Supplier, or Rental Company Certification:		
12. Name (first/last) of Corporate Official signing Certification		13. Title
14. Signature of Certifying Official		15. Date of Signature
<b>Lower Tier Sub-Contractor, Supplier, or Rental Company Certification</b>		
<p>I certify by my signature below that I have received a complete and unaltered copy of FHWA-1273 (Required Contract Provisions Federal-Aid Construction Contracts) and will comply with all requirements stipulated therein.</p>		
16. Tier Level		
17. Name of Lower Tier Sub-Contractor, Supplier, or Rental Company Certification:		
18. Name (first/last) of Corporate Official signing Certification		19. Title
20. Signature of Certifying Official		21. Date of Signature

CERTIFICATION REGARDING DEBARMENT, SUSPENSION,  
INELIGIBILITY AND VOLUNTARY EXCLUSION

**CERTIFICATION REGARDING DEBARMENT, SUSPENSION,  
INELIGIBILITY AND VOLUNTARY EXCLUSION-  
LOWER TIER COVERED TRANSACTIONS FOR FEDERAL AID CONTRACTS  
(Compliance with 2 CFR Parts 180 and 1200)**

It is certified that neither the below identified firm nor its principals are presently suspended, proposed for debarment, declared ineligible, or voluntarily excluded from participation in this transaction by any federal department or agency.

Name of Consultant/Contractor: \_\_\_\_\_

By: \_\_\_\_\_

Date: \_\_\_\_\_

Title: \_\_\_\_\_

Instructions for Certification

Instructions for Certification - Lower Tier Participants:

(Applicable to all subcontracts, purchase orders and other lower tier transactions requiring prior FHWA approval or estimated to cost \$25,000 or more - 2 CFR Parts 180 and 1200)

- a. By signing and submitting this proposal, the prospective lower tier is providing the certification set out below.
- b. The certification in this clause is a material representation of fact upon which reliance was placed when this transaction was entered into. If it is later determined that the prospective lower tier participant knowingly rendered an erroneous certification, in addition to other remedies available to the Federal Government, the department, or agency with which this transaction originated may pursue available remedies, including suspension and/or debarment.
- c. The prospective lower tier participant shall provide immediate written notice to the person to which this proposal is submitted if at any time the prospective lower tier participant learns that its certification was erroneous by reason of changed circumstances.
- d. The terms "covered transaction," "debarred," "suspended," "ineligible," "participant," "person," "principal," and "voluntarily excluded," as used in this clause, are defined in 2 CFR Parts 180 and 1200. You may contact the person to which this proposal is submitted for assistance in obtaining a copy of those regulations. "First Tier Covered Transactions" refers to any covered transaction between a grantee or subgrantee of Federal funds and a participant (such as the prime or general contract). "Lower Tier Covered Transactions" refers to any covered transaction under a First Tier Covered Transaction (such as subcontracts). "First Tier Participant" refers to the participant who has entered into a covered transaction with a grantee or subgrantee of Federal funds (such as the prime or general contractor). "Lower Tier Participant" refers any participant who has entered into a covered transaction with a First Tier Participant or other Lower Tier Participants (such as subcontractors and suppliers).
- e. The prospective lower tier participant agrees by submitting this proposal that, should the proposed covered transaction be entered into, it shall not knowingly enter into any lower tier covered transaction with a person who is debarred, suspended, declared ineligible, or voluntarily excluded from participation in this covered transaction, unless authorized by the department or agency with which this transaction originated.
- f. The prospective lower tier participant further agrees by submitting this proposal that it will include this clause titled "Certification Regarding Debarment, Suspension, Ineligibility and Voluntary Exclusion-Lower Tier Covered Transaction," without modification, in all lower tier covered transactions and in all solicitations for lower tier covered transactions exceeding the \$25,000 threshold.
- g. A participant in a covered transaction may rely upon a certification of a prospective participant in a lower tier covered transaction that is not debarred, suspended, ineligible, or voluntarily excluded from the covered transaction, unless it knows that the certification is erroneous. A participant is responsible for ensuring that its principals are not suspended, debarred, or otherwise ineligible to participate in covered transactions. To verify the eligibility of its principals, as well as the eligibility of any lower tier prospective participants, each participant may, but is not required to, check the Excluded Parties List System website (<https://www.epls.gov/>), which is compiled by the General Services Administration.
- h. Nothing contained in the foregoing shall be construed to require establishment of a system of records in order to render in good faith the certification required by this clause. The knowledge and information of participant is not required to exceed that which is normally possessed by a prudent person in the ordinary course of business dealings.
- i. Except for transactions authorized under paragraph e of these instructions, if a participant in a covered transaction knowingly enters into a lower tier covered transaction with a person who is suspended, debarred, ineligible, or voluntarily excluded from participation in this transaction, in addition to other remedies available to the Federal Government, the department or agency with which this transaction originated may pursue available remedies, including suspension and/or debarment.

CERTIFICATION FOR DISCLOSURE OF LOBBYING ACTIVITIES  
ON FEDERAL-AID CONTRACTS

STATE OF FLORIDA DEPARTMENT OF TRANSPORTATION  
**CERTIFICATION FOR DISCLOSURE OF LOBBYING ACTIVITIES  
ON FEDERAL-AID CONTRACTS  
(Compliance with 49CFR, Section 20.100 (b))**

375-030-33  
PROCUREMENT  
10/01

The prospective participant certifies, by signing this certification, that to the best of his or her knowledge and belief:

(1) No federal appropriated funds have been paid or will be paid, by or on behalf of the undersigned, to any person for influencing or attempting to influence an officer or employee of any federal agency, a Member of Congress, an officer or employee of Congress, or an employee of a Member of Congress in connection with the awarding of any federal contract, the making of any federal grant, the making of any federal loan, the entering into of any cooperative agreement, and the extension, continuation, renewal, amendment, or modification of any federal contract, grant, loan, or cooperative agreement.

(2) If any funds other than federal appropriated funds have been paid or will be paid to any person for influencing or attempting to influence an officer or employee of any federal agency, a Member of Congress, an officer or employee of Congress, or an employee of a Member of Congress in connection with this federal contract, grant, loan, or cooperative agreement, the undersigned shall complete and submit Standard Form-LLL, "Disclosure of Lobbying Activities", in accordance with its instructions. (Standard Form-LLL can be obtained from the Florida Department of Transportation's Professional Services Administrator or Procurement Office.)

This certification is a material representation of fact upon which reliance was placed when this transaction was made or entered into. Submission of this certification is a prerequisite for making or entering into this transaction imposed by Section 1352, Title 31, U.S. Code. Any person who fails to file the required certification shall be subject to a civil penalty of not less than \$10,000 and not more than \$100,000 for each such failure.

The prospective participant also agrees by submitting his or her proposal that he or she shall require that the language of this certification be included in all lower tier subcontracts, which exceed \$100,000 and that all such subrecipients shall certify and disclose accordingly.

Name of Consultant: \_\_\_\_\_

By: \_\_\_\_\_ Date: \_\_\_\_\_

Authorized Signature: \_\_\_\_\_

Title: \_\_\_\_\_

## DISCLOSURE OF LOBBYING ACTIVITIES

STATE OF FLORIDA DEPARTMENT OF TRANSPORTATION  
**DISCLOSURE OF LOBBYING ACTIVITIES**

375-030-34  
 PROCUREMENT  
 02/16

Is this form applicable to your firm?

YES  NO

If *no*, then please complete section 4 below for "Prime"

<b>1. Type of Federal Action:</b> a. contract b. grant c. cooperative agreement d. loan e. loan guarantee f. loan insurance	<b>2. Status of Federal Action:</b> a. bid/offer/application b. initial award c. post-award	<b>3. Report Type:</b> a. initial filing b. material change <b>For Material Change Only:</b> Year: _____ Quarter: _____ Date of last report: _____ (mm/dd/yyyy)
<b>4. Name and Address of Reporting Entity:</b> <input type="checkbox"/> Prime <input type="checkbox"/> Subawardee Tier _____, <i>if known</i> : _____ _____ _____ Congressional District, <i>if known</i> : 4c _____	<b>5. If Reporting Entity in No. 4 is a Subawardee, Enter Name and Address of Prime:</b> _____ _____ _____ Congressional District, <i>if known</i> : _____	
<b>6. Federal Department/Agency:</b> _____ _____	<b>7. Federal Program Name/Description:</b> _____ _____ CFDA Number, <i>if applicable</i> : _____	
<b>8. Federal Action Number, if known:</b> _____	<b>9. Award Amount, if known:</b> \$ _____	
<b>10. a. Name and Address of Lobbying Registrant</b> <i>(if individual, last name, first name, MI):</i> _____ _____ _____	<b>b. Individuals Performing Services</b> <i>(including address if different from No. 10a)</i> <i>(last name, first name, MI):</i> _____ _____ _____	
<b>11.</b> Information requested through this form is authorized by title 31 U.S.C. section 1352. This disclosure of lobbying activities is a material representation of fact upon which reliance was placed by the tier above when this transaction was made or entered into. This disclosure is required pursuant to 31 U.S.C. 1352. This information will be available for public inspection. Any person who fails to file the required disclosure shall be subject to a civil penalty of not less than \$10,000 and not more than \$100,000 for each such failure.	Signature: _____ Print Name: _____ Title: _____ Telephone No.: _____ Date (mm/dd/yyyy): _____	
<b>Federal Use Only:</b>		Authorized for Local Reproduction Standard Form LLL (Rev. 7-97)

## INSTRUCTIONS FOR COMPLETION OF SF-LLL, DISCLOSURE OF LOBBYING ACTIVITIES

This disclosure form shall be completed by the reporting entity, whether subawardee or prime Federal recipient, at the initiation or receipt of a covered Federal action, or a material change to a previous filing, pursuant to title 31 U.S.C. section 1352. The filing of a form is required for each payment or agreement to make payment to any lobbying entity for influencing or attempting to influence an officer or employee of any agency, a Member of Congress, an officer or employee of Congress, or an employee of a Member of Congress in connection with a covered Federal action. Complete all items that apply for both the initial filing and material change report. Refer to the implementing guidance published by the Office of Management and Budget for additional information.

1. Identify the type of covered Federal action for which lobbying activity is and/or has been secured to influence the outcome of a covered Federal action.
2. Identify the status of the covered Federal action.
3. Identify the appropriate classification of this report. If this is a followup report caused by a material change to the information previously reported, enter the year and quarter in which the change occurred. Enter the date of the last previously submitted report by this reporting entity for this covered Federal action.
4. Enter the full name, address, city, State and zip code of the reporting entity. Include Congressional District, if known. Check the appropriate classification of the reporting entity that designates if it is, or expects to be, a prime or subaward recipient. Identify the tier of the subawardee, e.g., the first subawardee of the prime is the 1st tier. Subawards include but are not limited to subcontracts, subgrants and contract awards under grants.
5. If the organization filing the report in item 4 checks "Subawardee," then enter the full name, address, city, State and zip code of the prime Federal recipient. Include Congressional District, if known.
6. Enter the name of the Federal agency making the award or loan commitment. Include at least one organizational level below agency name, if known. For example, Department of Transportation, United States Coast Guard.
7. Enter the Federal program name or description for the covered Federal action (item 1). If known, enter the full Catalog of Federal Domestic Assistance (CFDA) number for grants, cooperative agreements, loans, and loan commitments.
8. Enter the most appropriate Federal identifying number available for the Federal action identified in item 1 (e.g., Request for Proposal (RFP) number; Invitation for Bid (IFB) number; grant announcement number; the contract, grant, or loan award number; the application/proposal control number assigned by the Federal agency). Include prefixes, e.g., "RFP-DE-90-001."
9. For a covered Federal action where there has been an award or loan commitment by the Federal agency, enter the Federal amount of the award/loan commitment for the prime entity identified in item 4 or 5.
10. (a) Enter the full name, address, city, State and zip code of the lobbying registrant under the Lobbying Disclosure Act of 1995 engaged by the reporting entity identified in item 4 to influence the covered Federal action.  
  
(b) Enter the full names of the individual(s) performing services, and include full address if different from 10 (a). Enter Last Name, First Name, and Middle Initial (MI).
11. The certifying official shall sign and date the form, print his/her name, title, and telephone number.

According to the Paperwork Reduction Act, as amended, no persons are required to respond to a collection of information unless it displays a valid OMB Control Number. The valid OMB control number for this information collection is OMB No. 0348-0046. Public reporting burden for this collection of information is estimated to average 10 minutes per response, including time for reviewing instructions, searching existing data sources, gathering and maintaining the data needed, and completing and reviewing the collection of information. Send comments regarding the burden estimate or any other aspect of this collection of information, including suggestions for reducing this burden, to the Office of Management and Budget, Paperwork Reduction Project (0348-0046), Washington, DC 20503.



## NON-COLLUSION AFFIDAVIT



**NON-COLLUSION AFFIDAVIT**

*(In accordance with Sections 2-8.1.1 and 10-33.02.1 of the Code of Miami-Dade County)*

I, the undersigned, am over 18 years of age, have personal knowledge of the facts stated in the Non-Collusion Affidavit (*this Affidavit*) and I am an owner, officer, director, principal shareholder and/or otherwise authorized to bind the Bidder/Proposer of this solicitation.

A. I have reviewed the list of respondents attached to this Affidavit. I state that the Bidder/Proposer of this competitive solicitation (check one):

is **not related** to any of the other respondents submitting a Bid/Proposal in the competitive solicitation.

is **related** to the following respondents who submitted a Bid/Proposal in the competitive solicitation, which are identified and listed below:

B. I state that the Bidder/Proposer of this competitive solicitation:

1. has prepared this Bid/Proposal independently without consultation, communication, agreement or arrangement with any other Bidder/Proposer or competitor for the purpose of restricting competition;
2. has submitted the Bid/Proposal in its own behalf, and not in the interest or on behalf of any person not therein named;
3. has not, directly or indirectly, induced or solicited any other Bidder/Proposer to put in a sham proposal, or any other person, firm, or corporation to refrain from proposing;
4. has not in any manner sought by collusion to secure an advantage over any other Bidder/Proposer.

**Note:** Any person or entity that fails to submit this executed Affidavit shall be ineligible for contract award. In accordance with Section 2-8.1.1 of the Code of Miami-Dade County, where two or more related parties, as defined herein, each submit a Bid for any contract, such Bids shall be presumed to be collusive. The foregoing presumption may be rebutted by the presentation of evidence as to the extent of ownership, control and management of such related parties in preparation and submittal of such Bids. **Related parties** shall mean the Bidder/Proposer; the principals, corporate officers, and managers of a Bidder/Proposer; or the spouse, domestic partner, parents, stepparents, siblings, children or stepchildren of a Bidder/Proposer or the principals, corporate officers and managers thereof which have a direct or indirect ownership interest in another Bidder/Proposer for the same contract or in which a parent company or the principals thereof of one Bidder/Proposer have a direct or indirect ownership interest in another Bidder/Proposer for the same contract. Bid/Proposal found to be collusive shall be rejected. Bidder/Proposer who has been found to have engaged in collusion may be considered non-responsible, and may be suspended or debarred, and any contract resulting from collusive bidding may be terminated for default.

**Written Declaration:** Pursuant to §92.525, Florida Statutes, under penalties of perjury, I declare that I have read the foregoing Affidavit and that the facts stated in it are true, accurate, and complete.

Solicitation No.: \_\_\_\_\_ Solicitation Title: \_\_\_\_\_

By: \_\_\_\_\_  
Signature of Affiant

Date: \_\_\_\_\_ 20 \_\_\_\_

\_\_\_\_\_  
Printed Name of Affiant and Title

\_\_\_\_/\_\_\_\_/\_\_\_\_-\_\_\_\_/\_\_\_\_/\_\_\_\_/\_\_\_\_/\_\_\_\_  
Federal Employer Identification Number

\_\_\_\_\_  
Printed Name of Bidder/Proposer

\_\_\_\_\_  
Address of Bidder/Proposer

## AFFIRMATION OF VENDOR AFFIDAVITS



# New Vendor Registration and Bid/Proposal Contract Language

## 1.1. DEFINITIONS FOR VENDOR REGISTRATION

**Bid** – shall refer to any offer(s) submitted in response to this solicitation.

**Bidder** – shall refer to anyone submitting a Bid in response to this solicitation.

**Bid Solicitation** – shall mean this solicitation documentation, including any and all addenda.

**Bid Submittal Form** – defines the requirement of items to be purchased, and must be completed and submitted with Bid. The Bidder should indicate its name in the appropriate space on each page.

**County** – shall refer to Miami-Dade County, Florida

**DPM** – shall refer to Miami-Dade County's Department of Procurement Management.

**Enrolled Vendor** – shall refer to a firm that has completed the necessary documentation in order to receive Bid notifications from the County.

**Registered Vendor** – shall refer to a firm that has completed the Miami-Dade County Business Entity Registration Application and has satisfied all requirements to enter into business agreements with the County.

**The Vendor Registration Package** – shall refer to the Business Entity Registration Application.

For additional information about on-line vendor enrollment or vendor registration contact the Vendor Assistance Unit at 111 N.W. 1<sup>st</sup> Street, 13<sup>th</sup> Floor, Miami, FL 33128, Phone 305-375-5773. Vendors can enroll online and obtain forms to register by visiting our web site at [www.miamidade.gov/dpm](http://www.miamidade.gov/dpm)

## 1.2. INSTRUCTIONS TO BIDDERS

### A. Bidder Qualification

It is the policy of the County to encourage full and open competition among all available qualified vendors. All vendors regularly engaged in the type of work specified in the Bid Solicitation are encouraged to submit Bids. Vendors may enroll with the County to be included on a notification list for selected categories of goods and services. To be eligible for award of a contract (including small purchase orders), Bidders must become a Registered Vendor. Only Registered Vendors can be awarded County contracts. Vendors are required to register with the County by contacting the Vendor Assistance Unit. The County endeavors to obtain the participation of all qualified small business enterprises. For information and to apply for certification, contact the Department of Small Business Development at 111 N.W. 1<sup>st</sup> Street, 19<sup>th</sup> Floor, Miami, FL 33128-1900, or telephone at 305-375-3111. County employees and board members wishing to do business with the County are referred to Section 2-11.1 of the Miami-Dade County Code relating to Conflict of Interest and Code of Ethics.

### B. Vendor Registration

To be recommended for award the County requires that vendors complete a Miami-Dade County Vendor Registration Package. Effective June 1, 2008, a new Vendor Registration Package, including a Uniform Affidavit Packet (Affidavit form), must be completed by vendors and returned to the Department of Procurement Management (DPM), Vendor Assistance Unit, within fourteen (14) days of notification of the intent to recommend for award. In the event the Vendor Registration Package is not properly completed and returned within the specified time, the County may in its sole discretion, award to the next lowest responsive, responsible Bidder. The Bidder is responsible for obtaining the Vendor Registration Package, including all affidavits by downloading from the DPM website at [www.miamidade.gov](http://www.miamidade.gov) or from the Vendor Assistance Unit at 111 N.W. 1<sup>st</sup> Street, 13<sup>th</sup> Floor, Miami, FL 33128.

Bidders are required to affirm that all information submitted with the Vendor Registration Package is current, complete and accurate, at the time they submit a response to a Bid Solicitation, by completing the provided Affirmation of Vendor Affidavit form.

In becoming a Registered Vendor with Miami-Dade County, the vendor confirms its knowledge of and commitment to comply with the following:

1. **Miami-Dade County Ownership Disclosure Affidavit**  
(Sec. 2-8.1 of the County Code)
2. **Miami-Dade County Employment Disclosure Affidavit**  
(County Ordinance No. 90-133, amending Section 2-8.1(d)(2) of the County Code)
3. **Miami-Dade County Employment Drug-free Workplace Certification**  
(Section 2-8.1.2(b) of the County Code)
4. **Miami-Dade Disability and Nondiscrimination Affidavit**  
(Article 1, Section 2-8.1.5 Resolution R182-00 Amending R-385-95)
5. **Miami-Dade County Debarment Disclosure Affidavit**  
(Section 10.38 of the County Code)
6. **Miami-Dade County Vendor Obligation to County Affidavit**  
(Section 2-8.1 of the County Code)
7. **Miami-Dade County Code of Business Ethics Affidavit**  
(Article 1, Section 2-8.1(j) and 2-11(b)(1) of the County Code through (6) and (9) of the County Code and County Ordinance No 00-1 amending Section 2-11.1(c) of the County Code)
8. **Miami-Dade County Family Leave Affidavit**  
(Article V of Chapter 11 of the County Code)

9. **Miami-Dade County Living Wage Affidavit**  
(Section 2-8.9 of the County Code)

10. **Miami-Dade County Domestic Leave and Reporting Affidavit**  
(Article 8, Section 11A-60 11A-67 of the County Code)

11. **Subcontracting Practices**  
(Ordinance 97-35)

12. **Subcontractor /Supplier Listing**  
(Ordinance 97-104)

13. **Environmentally Acceptable Packaging**  
Resolution (R-738-92)

14. **W-9 and 8109 Forms**

The vendor must furnish these forms as required by the Internal Revenue Service.

15. **Social Security Number**

In order to establish a file for your firm, you must provide your firm's Federal Employer Identification Number (FEIN). If no FEIN exists, the Social Security Number of the owner or individual must be provided. This number becomes your "County Vendor Number". To comply with Section 119.071(5) of the Florida Statutes relating to the collection of an individual's Social Security Number, be aware that DPM requests the Social Security Number for the following purposes:

- Identification of individual account records
- To make payments to individual/vendor for goods and services provided to Miami-Dade County
- Tax reporting purposes
- To provide a unique identifier in the vendor database that may be used for searching and sorting departmental records

16. **Office of the Inspector General**

Pursuant to Section 2-1076 of the County Code.

17. **Small Business Enterprises**

The County endeavors to obtain the participation of all small business enterprises pursuant to Sections 2-8.2, 2-8.2.3 and 2-8.2.4 of the County Code and Title 49 of the Code of Federal Regulations.

18. **Antitrust Laws**

By acceptance of any contract, the vendor agrees to comply with all antitrust laws of the United States and the State of Florida.

### C. PUBLIC ENTITY CRIMES

To be eligible for award of a contract, firms wishing to do business with the County must comply with the following:

Pursuant to Section 287.133(2)(a) of the Florida Statutes, a person or affiliate who has been placed on the convicted vendor list following a conviction for a public entity crime may not submit a Bid on a contract to provide any goods or services to a public entity, may not submit a Bid on a contract with a public entity for the construction or repair of a public building or public work, may not submit Bids on leases of real property to a public entity, may not be awarded or perform work as a contractor, supplier, subcontractor, or consultant under a contract with any public entity, and may not transact business with any public entity in excess of the threshold amount provided in Section 287.017 of the Florida Statutes, for CATEGORY TWO for a period of 36 months from the date of being placed on the convicted vendor list.



Miami-Dade County  
Department of Procurement Management  
**Affirmation of Vendor Affidavits**

In accordance with Ordinance 07-143 amending Section 2-8.1 of the Code of Miami-Dade County, effective June 1, 2008 (for goods and services) and July 1, 2008 (for design and construction), vendors are required to complete a new Vendor Registration Package, including a Uniform Affidavit Packet (Vendor Affidavits Form), before being awarded a new contract. The undersigned affirms that the Vendor Affidavits Form submitted with the Vendor Registration Package is current, complete and accurate for each affidavit listed below.

**Contract No. :** \_\_\_\_\_ **Federal Employer Identification Number (FEIN):** \_\_\_\_\_

**Contract Title:** \_\_\_\_\_

**Affidavits and Legislation/ Governing Body**

1.	<b>Miami-Dade County Ownership Disclosure</b> <i>Sec. 2-8.1 of the County Code</i>	6.	<b>Miami-Dade County Vendor Obligation to County</b> <i>Section 2-8.1 of the County Code</i>
2.	<b>Miami-Dade County Employment Disclosure</b> <i>County Ordinance No. 90-133, amending Section 2-8-1(d)(2) of the County Code</i>	7.	<b>Miami-Dade County Code of Business Ethics</b> <i>Article 1, Section 2-8.1(i) and 2-11(b)(1) of the County Code through (6) and (9) of the County Code and County Ordinance No 00-1 amending Section 2-11.1(c) of the County Code</i>
3.	<b>Miami-Dade County Employment Drug-free Workplace Certification</b> <i>Section 2-8.1.2(b) f the County Code</i>	8.	<b>Miami-Dade County Family Leave</b> <i>Article V of Chapter 11, Resolution No. R-183-00 amending Resolution No. R – 1499-91 of the County Code</i>
4.	<b>Miami-Dade County Disability Non-Discrimination</b> <i>Article 1, Section 2-8.1.5 Resolution R182-00 amending R-385-95</i>	9.	<b>Miami-Dade County Living Wage</b> <i>Section 2-8.9 of the County Code</i>
5.	<b>Miami-Dade County Debarment Disclosure</b> <i>Section 10.38 of the County Code</i>	10.	<b>Miami-Dade County Domestic Leave and Reporting</b> <i>Article 8, Section 11A-60 11A-67 of the County Code</i>

Printed Name of Affiant	Printed Title of Affiant	Signature of Affiant
Name of Firm	Date	
Address of Firm	State	Zip Code

**Notary Public Information**

Notary Public – State of \_\_\_\_\_ County of \_\_\_\_\_

**Subscribed and sworn to** (or affirmed) before me this \_\_\_\_\_ day of, \_\_\_\_\_ 20 \_\_\_\_\_.

by \_\_\_\_\_ He or she is personally known to me  or has produced identification

Type of identification produced \_\_\_\_\_

Signature of Notary Public	Serial Number
Print or Stamp of Notary Public	Notary Public Seal

Expiration Date

# FAIR WAGE AFFIDAVIT

**FAIR WAGE AFFIDAVIT**

Before me, the undersigned authority appeared \_\_\_\_\_ the  
(PRINT NAME)

\_\_\_\_\_ of \_\_\_\_\_,  
(PRINT TITLE) (PRINT NAME OF BIDDER OR PROPOSER)

who attests that \_\_\_\_\_ shall pay workers on  
(PRINT NAME OF BIDDER OR PROPOSER)

the project minimum wage rates in accordance with Responsible Wages and Benefits, Section 2-11.16 of the Code of Miami-Dade County and the Labor Provisions of the contract documents.

**State of FLORIDA**

**County of Miami-Dade**

Sworn to (or affirmed) and subscribed before me this \_\_\_\_\_ day of \_\_\_\_\_, 202\_\_\_\_\_.

\_\_\_\_\_ Personally, known or \_\_\_\_\_ produced identification.

\_\_\_\_\_  
(Signature of Notary Public - State of Florida)

\_\_\_\_\_  
(Print, Type, or Stamp Commissioned Name of Notary Public)

Type of identification produced: \_\_\_\_\_



# CONTRACTOR DUE DILIGENCE AFFIDAVIT



Miami-Dade County

Contractor Due Diligence Affidavit

Per Miami-Dade County Board of County Commissioners (Board) Resolution No. R-63-14, County Vendors and Contractors shall disclose the following as a condition of award for any contract that exceeds one million dollars (\$1,000,000) or that otherwise must be presented to the Board for approval:

- (1) Provide a list of all lawsuits in the five (5) years prior to bid or proposal submittal that have been filed against the firm, its directors, partners, principals and/or board members based on a breach of contract by the firm; include the case name, number and disposition;
(2) Provide a list of any instances in the five (5) years prior to bid or proposal submittal where the firm has defaulted; include a brief description of the circumstances;
(3) Provide a list of any instances in the five (5) years prior to bid or proposal submittal where the firm has been debarred or received a formal notice of non-compliance or non-performance, such as a notice to cure or a suspension from participating or bidding for contracts, whether related to Miami-Dade County or not.

All of the above information shall be attached to the executed affidavit and submitted to the Procurement Contracting Officer (PCO)/ AE Selection Coordinator overseeing this solicitation. The Vendor/Contractor attests to providing all of the above information, if applicable, to the PCO.

Contract No. : \_\_\_\_\_ Federal Employer Identification Number (FEIN): \_\_\_\_\_

Contract Title: \_\_\_\_\_

Printed Name of Affiant Printed Title of Affiant Signature of Affiant

Name of Firm Date

Address of Firm State Zip Code

Notary Public Information

Notary Public - State of \_\_\_\_\_ County of \_\_\_\_\_

Subscribed and sworn to (or affirmed) before me this \_\_\_\_\_ day of, \_\_\_\_\_ 20

by \_\_\_\_\_ He or she is personally known to me [ ] or has produced identification

Type of identification produced \_\_\_\_\_

Signature of Notary Public Serial Number

Print or Stamp of Notary Public Expiration Date Notary Public Seal

## **SECTION 3: INSTRUCTIONS TO BIDDERS**

## SUPPLEMENTARY INSTRUCTIONS TO BIDDERS

# SUPPLEMENTARY INSTRUCTIONS TO BIDDERS

## TABLE OF CONTENTS

### 1. SUPPLEMENTAL BIDDING REQUIREMENTS

---

1.01	BID FORMS.....	1
1.02	BID SECURITY .....	2
1.03	CERTIFICATION PURSUANT TO ACT RELATING TO SCRUTINIZED COMPANIES .....	2
1.04	SMALL BUSINESS ENTERPRISE-CONSTRUCTION PROGRAM .....	2
1.05	DISADVANTAGED BUSINESS ENTERPRISE (DBE) PROGRAM.....	3
1.06	SITE INVESTIGATION.....	3
1.07	CONTRACTOR QUALIFICATION REQUIREMENTS .....	4
1.08	AWARD OF CONTRACT .....	5
1.09	PAYMENT AND PERFORMANCE BONDS .....	6
1.10	ADDITIONAL INSURANCE TO BE CARRIED BY CONTRACTOR .....	7

## 1. SUPPLEMENTAL BIDDING REQUIREMENTS

---

### 1.01 BID FORMS

#### A. Estimated Quantities.

1. The Bid Form contains estimated quantities that are provided for bidding purposes only. The actual quantities required to construct the Work may vary from those shown. The County reserves the right to increase, or decrease the quantities, or to delete any of the items for which there is no need throughout the length of the Contract.
2. Bid Items which are estimated with a unit quantity of one are anticipated to be use in minimal quantities, if any, as approved by the Engineer. Any Contract provisions pertaining to adjustments in item prices shall not apply. Therefore, no adjustment shall be made to the unit prices awarded as a result of changes to the estimated quantities provided in the Bid Form. Final quantities shall be as approved by the Engineer.

#### B. Preparation of Proposal.

1. All blank spaces on the Bid Form for bid prices must be filled in ink, in both words and figures. In the event of any discrepancy in the entries for the price of any item, the unit price as shown in words shall govern unless both the extension and the unit prices shown in figures are in agreement with each other, in which case they shall govern over the unit price shown in words.
2. If the Bid is made by an individual, a sole proprietorship or an individual operating under a trade name, the name and post office address of the individual or owner must be shown in each instance. If made by a partnership, the Bid must be signed by one of the partners, and the names and addresses of the partners must be listed. If made by a corporation, the Bid must be signed by an authorized officer or agent of the corporation, the corporation must be clearly identified, and the corporate seal must be affixed. In addition, a Bid made by a corporation must also list the name of the state wherein the corporation was chartered and the business address of the corporation.
3. Bids must be submitted only on the hardcopy Bid form provided with these Contract Documents unless a revised Bid Form is provided by the County via Addendum, in which case the latest Bid Form provided by Addendum shall be used.
4. All required forms must be completed and submitted and, all blanks must be filled in.

#### C. Rejection of Irregular Proposals.

1. Bids will be considered irregular, and may be rejected, if they show omissions, alterations of form, additions not called for, conditions or unauthorized alternate bids, or irregularities of any kind; or if the unit prices are obviously unbalanced either in excess of or below a reasonable cost analysis value.

#### D. Pay Items.

1. Any work not specifically mentioned in the pay items listed in the Proposal, but indicated on the plans and/or specifications, shall be considered as incidental to one or more of the pay items, and no claim for additional compensation will be allowed, and it shall be assumed that the cost therefore is included in the prices for the various items in the Contract.

## 1.02 BID SECURITY

- A. Simultaneously with the delivery of the Bid to the County, on or before the bid due date, the Bidder must deliver to the County a bid security in the form of a Bid Bond on the form provided in the Bidding Documents or in Cash, in the form of a Certified Check, Cashier's Check or Irrevocable Letter of Credit made payable to the Department, for an amount equal to no less than five percent of the Total amount Bid. Failure to furnish a bid security in the proper form and amount, with the delivery of the Bid to the County, shall result in the Bid being declared "non-responsive."
- B. A Bid Bond shall have as the surety thereon only such surety company or companies that are acceptable to the County and are authorized to write bonds of such character and amount in accordance with the qualifications established for Payment and Performance Bonds.
- C. The bid security submitted with the Bid becomes payable to the County upon default of the Bidder. Default of Bidder shall occur in the event that the Bidder withdraws Bid within 180 days after bid opening (or any extension thereof agreed to in writing by the Bidder and County); or, after proper notification of intent to Contract from the County, fails to comply with all pre-award requirements including, but not limited to providing Payment and Performance Bonds with good and sufficient surety and the necessary Insurance Certificates pursuant to the Contract Documents, and enter into a written Contract with the County, as may be required; all within 10 days after the prescribed forms are presented to Principal for signature or as otherwise required by these Bidding Documents..

## 1.03 CERTIFICATION PURSUANT TO ACT RELATING TO SCRUTINIZED COMPANIES

- A. This section shall apply only to the extent permitted under applicable regulations of the United States Department of State and the United States Department of Treasury.
- B. By submitting a bid executed through a duly authorized representative, the bidder certifies that the bidder is not on the Scrutinized Companies with Activities in Sudan List, Scrutinized Companies with Activities in the Iran Petroleum Energy Sector List, Scrutinized Companies that boycott Israel List or engaged in a boycott of Israel as those terms are used and defined in sections 287.135 and 215.473 of the Florida Statutes. In the event that the bidder is unable to provide such certification but still seeks to be considered for award of this solicitation, the bidder shall, on a separate piece of paper, clearly state that it is on one or both of the Scrutinized Companies lists and shall furnish together with its bid a duly executed written explanation of the facts supporting any exception to the requirement for certification that it claims under Section 287.135 of the Florida Statutes. The bidder agrees to cooperate fully with the County in any investigation undertaken by the County to determine whether the claimed exception would be applicable. The County shall have the right to terminate any contract resulting from this solicitation for default if the bidder is found to have submitted a false certification or to have been placed on the Scrutinized Companies for Activities in Sudan List, the Scrutinized Companies with Activities in the Iran Petroleum Energy Sector List, Scrutinized Companies that boycott Israel List or engaged in a boycott of Israel.

## 1.04 SMALL BUSINESS ENTERPRISE-CONSTRUCTION PROGRAM

- A. Miami-Dade County web-based Business Management Workforce System (BMWS)
  - 1. The Subject project is a federally funded project (FEMA Reimbursement), the instruction below is only to collect information from contractors and to track payments, the subject project does not have any SBD or local preference program. It is reported through the FDOT DBE Program.

2. Bidders must register under Miami-Dade County web-based Business Management Workforce System (BMWS). BMWS is managed by the Small Business Development (SBD) Division of the Internal Services Department. BMWS will be utilized to apply online for Small Business Enterprise (SBE) certification, manage County contracts, and track compliance with SBE Program measures, Workforce Program requirements, and subcontractor payments.
3. The use of this web-based system is mandatory for firms contracting with Miami-Dade County for the submission and verification of payment information and certified payrolls. Training for BMWS can be offered at the following web address: <https://mdcsbd.gob2g.com/>
1. BMWS will be accessible, at no charge, to all vendors doing – or interested in doing – business with Miami-Dade County. Key features include:
  - a. Online application for Small Business Enterprise (SBE), Disadvantaged Business Enterprise (DBE) and Local Developing Business (LDB) certification
  - b. Online registration for the Equitable Distribution Program (EDP)
  - c. Enhanced online SBE, DBE, and LDB Directory, with key-word search capabilities
  - d. Electronic submission of subcontractors for fulfillment of SBE requirements
  - e. Electronic submission of contractors' utilization payments and verification of SBE payments via the web or a mobile device
  - f. Automated tracking of progress towards meeting SBE goals
  - g. Electronic submission of certified payrolls
  - h. Electronic submission of workforce compliance data
  - i. Automated notifications regarding compliance requirements
  - j. Elimination of/or limited paper-based reporting
- B. Small Business Enterprise-Construction Program Measures
  1. In accordance with Miami-Dade County Ordinances No. 97-52, 14-98, and 97-158; A.O. 3-22, no SBE-CONST Measures have been established for this Project.

#### 1.05 DISADVANTAGED BUSINESS ENTERPRISE (DBE) PROGRAM

- A. The Contractor shall comply with the requirements pursuant to 49 Code of Federal Regulations (CFR) Part 26 as implemented by the approved FDOT DBE Program.
- B. For more information on the DBE Program refer to Article 1.10 of the Supplementary Conditions of these Solicitation Documents.

#### 1.06 SITE INVESTIGATION

- A. Examine the Contract Documents and the site of the proposed work, when applicable, carefully before submitting a proposal for the work contemplated. Investigate the conditions to be encountered, as to the character, quality, and quantities of work to be performed and materials to be furnished and as to the requirements of all Contract Documents.
- B. The bidder's submission of a proposal is sufficient evidence that the bidder has made an examination as described in this Article. Therefore:

1. The bidder, by virtue of submitting their bid, acknowledges that they and all their subcontractors have satisfied themselves as to the nature and location of the Work or requirements of similar Work to be performed within Miami-Dade County Public Right-of-Ways. The general and local conditions include, but are not restricted to those bearing upon transportation and traffic maintenance; the disposal, handling and storage of materials; access roads to the site; site constraints, restrictions and limitations; the conformation and conditions of the work area; and the character of equipment and facilities needed prior to and during the performance of the Work.
2. Failure on the part of the bidder to completely or properly evaluate any factors of costs prior to bidding shall not form a basis for additional compensation if awarded the Contract.

## 1.07 CONTRACTOR QUALIFICATION REQUIREMENTS

### A. Certificate of Competency Requirement:

1. At the time of Bid and pursuant to the requirements of Section 10-3 of the Code of Miami-Dade County, Florida and these Solicitation and Contract Documents, the Bidder must hold a valid, current, and active:
  - a. At the time of Bid and pursuant to the requirements of Section 10-3 of the Code of Miami-Dade County, Florida and these Solicitation and Contract Documents, the Bidder must hold a valid, current, and active Certificate of Competency as a General Engineering Contractor or as a Specialty Engineering Contractor, commensurate to the requirements of the Project's Scope of Work, in one or more engineering crafts to include Structural Engineering. The Specialty Contractor shall subcontract with a qualified contractor any work which is incidental to the specialty but is specified in the aforementioned Code as being the work of other than that of the Engineering Specialty for which certified; or
  - b. Pursuant to Section 255.20, Florida Statutes (F.S.) and in lieu of the above, the County may consider a bid from a Bidder that is a duly licensed Contractor in good standing that has been pre-qualified and considered eligible by the Florida Department of Transportation (FDOT) under Section 337.14, F.S. and Chapter 14-2, Florida Administrative Code, to perform the work described in the Contract Documents. Contractors seeking consideration under this paragraph shall submit along with the Bid Documents for review and consideration, current copy(ies) of their FDOT Certificate(s) of Qualification, Certification of Work Underway, and Status of Contract(s) On Hand. Acceptable FDOT prequalification(s) necessary to perform the work specified in the Project's Scope of Work shall include the Minor, or Major bridge Work Class.

### B. Experience Requirement:

1. The Bidder must demonstrate that it has full-time personnel with the necessary experience to perform the Project's Scope of Work. This experience shall include work in successfully completed projects performed by the identified personnel whose bulk of work performed in the Public Right-of-Way is similar in detail to the Project's Scope of Work described in these Solicitation Documents. Demonstrate the experience requirement by:
  - a. Providing a detailed description of at least three (3) projects similar in detail to the Project's Scope of Work described in these Solicitation Documents and in which the Bidder's identified personnel is currently engaged or has completed within the past five years. List and describe the aforementioned projects and state whether the work was performed for the County, other government clients, or private entities. The description must identify for each project:



- 1) The identified personnel and their assigned role and responsibilities for the listed project
  - 2) The client name and address including a contact person and phone number for reference
  - 3) Description of work
  - 4) Total dollar value of the contract
  - 5) Contract duration
  - 6) Statement or notation of whether Bidder's referenced personnel is/was employed by the prime contractor or subcontractor, and
  - 7) For completed projects, provide letters of certification of final acceptance or similar project closure documentation issued by the client and available Contractor's performance evaluations; or
2. The County reserves the right to request additional information and/or contact listed persons pertaining to bidder's experience.

#### 1.08 AWARD OF CONTRACT

- A. The award of the Contract, if it be made in the County's sole discretion, shall be to the lowest responsive and responsible bidder whose bid complies with all of the material terms of this solicitation and is determined to be in the best interest of the County.
- B. A fully executed Notice to Proceed (NTP) Letter constitutes a contract with Miami-Dade County. The County may issue to the Contractor a NTP Letter only when, in the discretion of Miami-Dade County, all conditions for award have been satisfied including, but not limited to, compliance with all of the requirements set forth in the Recommendation for Award letter and the expiration of any applicable protest period. The Contractor must provide the County with the completed and fully executed NTP Letter prior to the date stated in the letter for commencement of the Work. The award is final only upon the County's receipt of a fully executed NTP Letter from the Contractor.
- C. Without limiting the generality of the foregoing, the County may determine that it is in the County's best interest to award the Contract to the next low bidder when the low bidder's existing contractual commitments with the County, in the sole discretion of the County (a) could prevent the timely prosecution of the work requiring competing commitments of site, supervisory or home office personnel, or (b) could present potential conflicts with billing of similar items under existing contracts for similar or related work, or (c) could disfavor competition in the contracting industry in pricing or in the use of personnel or subcontractors.
- D. By submitting a bid, the bidder acknowledges that the County shall have the right to investigate the existence of these factors in determining whether to award the bid, and to evaluate, without limitation, the bidder's outstanding commitments on other awarded contracts, its resources to perform the Work under the Contract, and its past performance.
- E. The County reserves the right to waive any informality in, or to reject any or all bids. Bids from any person, firm or corporation in default upon any agreement with the County will be rejected.
- F. The Bidders should be qualified by experience, financing, and equipment to do the work described in the Contract Documents. The County may require from the apparent lowest responsive and responsible Bidder, as a condition for Award, a list of the major construction equipment that is available to perform all the work required by the Contract. The list shall include all equipment

required and available including: quantity; condition; make and model; whether owned or leased; and their present location. Actual proof of ownership (bills of sale or certified proof of a valid lease in the name of the firm submitting the Bid) of the equipment or the ability to secure the equipment prior to Contract Award is required. A visual inspection by the County of the equipment listed shall be facilitated within 10 days of submittal of the aforementioned list. Failure to meet the timeframes and conditions stipulated herein or in the Recommendation for Award may result in the disqualification of the Bidder.

1.09 PAYMENT AND PERFORMANCE BONDS

- A. The successful bidder shall submit, within the timeframe stipulated in the Recommendation for Award, duly executed Payment and Performance Bonds, meeting the requirements of Section 255.05, F.S., on the forms prescribed by the Department or in Cash, each in the amount of the total contract price (i.e. the accepted total amount bid plus any contingency and dedicated allowances attributable to the Contract), as security for the faithful performance of this Contract and for the payment of all persons performing labor or furnishing materials in connection therewith. If Cash is used in lieu of the bonds, all terms and conditions stipulated in the bonds shall be just as applicable.
- B. Per Resolution R-593-13, no payment and performance bond shall be required for a contract of \$200,000 or less.
- C. The Performance and Payment Bonds shall have as the surety thereon only such surety company or companies as are acceptable to the County and are authorized to write bonds of such character and amount in accordance with the following qualifications:
  - 1. All bonds shall be written through surety insurers authorized to do business in the State of Florida as surety, with the following qualifications as to management and financial strength according to the latest edition of Best's Insurance Guide, published by A.M. Best Company, Oldwick, New Jersey:

<u>Bond Amount (\$)</u>	<u>Best Rating</u>
500,001 to 1,500,000	B V
1,500,001 to 2,500,000	A VI
2,500,001 to 5,000,000	A VII
5,000,000 to 10,000,000	A VIII
Over 10,000,000	A IX

- 2. On contract amounts of \$500,000 or less, the bond provisions of Section 287.0935, F.S. shall be in effect and surety companies not otherwise qualifying with this paragraph may optionally qualify by:
  - a. Providing evidence that the Surety has twice the minimum surplus and capital required by the Florida Insurance Code at the time the invitation to bid is issued.
  - b. Certifying that the Surety is otherwise in compliance with the Florida Insurance Code, and;
  - c. Providing a copy of the currently valid Certificate of Authority issued by the United States Department of the Treasury under ss. 31 U.S.C. 9304-9308.

3. Surety insurers shall be listed in the latest Circular 570 of the U.S. Department of the Treasury entitled "Surety Companies Acceptable on Federal Bonds", published annually. The bond amount shall not exceed the underwriting limitations as shown in this circular.
  4. For contracts in excess of \$500,000 the provision of Subarticle 2 above will be adhered to plus the company must have been listed for at least three consecutive years, or holding a valid Certificate of Authority of at least 1.5 million dollars and on the Treasury List.
  5. Surety Bonds guaranteed through U.S. Government Small Business Administration or Contractors Training and Development Inc. will also be acceptable.
  6. The attorney-in-fact or other officer who signs performance and payment bonds for a surety company must file with such bond a certified copy of his power of attorney authorizing him to do so. The performance and payment bonds must be counter signed by the surety's resident Florida agent.
- D. The Payment and Performance Bonds must be executed on the forms provided by the Department after the recommendation of award has been made. Failure to do so shall result in the rescission of the contract award recommendation.
  - E. Provide the County with three executed originals of the Payment and Performance Bonds and a letter from the bonding agent granting Miami-Dade County authorization to date the Bonds.
  - F. The Performance Bond or Cash used in lieu of the Performance Bond shall remain in force for five (5) years from the date of final acceptance of the work to protect the County against losses resulting from defects in materials or improper performance of work under the Contract; provided however, that this limitation does not apply to suits seeking damages for latent defects in materials or workmanship, such actions being subject to the limitations found in Section 95.11(3)(c), Florida Statutes.
  - G. The cost of the bond(s) shall be included in the Total Amount Bid. No separate payment for the cost of said bond(s) shall be made by the County.
  - H. The required bond(s) shall be written by or through and countersigned by a licensed Florida agent of the surety insurer pursuant to Section 624.425, F.S.
  - B. In the event the Surety on the bond(s) given by the Contractor becomes insolvent, or is placed in the hands of a receiver, or has its right to do business in its State of domicile or the State of Florida suspended or revoked as provided by law, or in the event of cancellation of the required hands by the Surety, the County shall withhold all payments until the Contractor shall give good and sufficient bond(s) in lieu of the bond(s) executed by such Surety.

#### 1.10 ADDITIONAL INSURANCE TO BE CARRIED BY CONTRACTOR

Subparagraphs 2.9A through 2.9C and 2.9E through 2.9G of the Special Conditions to the CICC 7360-0/08 Contract are deleted and replaced with the following:

- A. To the extent provided by law, Contractor shall indemnify, defend, and hold harmless the County, and the Department of Transportation, including the Department's officers, agents, and employees, against any actions, claims, or damages arising out of, relating to, or resulting from negligent or wrongful act(s) of the Contractor, or any of its officers, agents, or employees, acting within the scope of their office or employment, in connection with the rights granted to or exercised by the Contractor hereunder, to the extent and within the limitations of Section 768.28, Florida Statutes.

- B. The foregoing indemnification shall not constitute a waiver of sovereign immunity beyond the limits set forth in Florida Statutes, Section 768.28. Nor shall the same be construed to constitute agreement by Contractor to indemnify County for the negligent acts or omissions of County, its officers, agents, or employees, or third parties. Nor shall the same be construed to constitute agreement by the Contractor to indemnify the Department for the negligent acts or omissions of the Department, its officers, agents, or employees, or third parties. This indemnification shall survive the termination of this Agreement.
- C. This indemnification shall survive the termination of this Agreement. Nothing contained in this paragraph is intended to nor shall it constitute a waiver of the State of Florida and the County's sovereign immunity.
- D. Contractor shall furnish to the Department of Transportation and Public Works, 111 NW 1 Street, Miami Florida 33128, Certificate(s) of Insurance which indicate that insurance coverage has been obtained which meets the requirements as outlined below:

- 1. Worker's Compensation Insurance for all employees of the Contractor as required by Florida Statute 440.

As applicable should include coverage required under the U.S. Longshoremen and Harbor Workers' Act (USL&H) and/or Jones Act for any activities on or about navigable water.

- 2. Commercial General Liability Insurance in an amount not less than \$1,000,000 per occurrence, and \$2,000,000 in the aggregate, not to exclude Products & Completed Operations.. Miami-Dade County shall be included as additional insured.
- 3. Automobile Liability Insurance covering all owned, non-owned and hired vehicles used in connection with the work, in an amount not less than \$1,000,000 combined single limit per occurrence for bodily injury and property damage.

In addition to the insurance coverages listed above the Contractor and/or sub-contractor that owns the barge(s) and/or vessel(s) must provide the following insurance coverage:

- 1. Protection and Indemnity Insurance in the name of the vessel owner, in an amount not less than \$1,000,000 per occurrence. Miami-Dade County must be shown as an additional insured with respect to this coverage.

- E. All insurance policies required above shall be issued by companies authorized to do business under the laws of the State of Florida, with the following qualifications:
  - a. The company must be rated no less than "A-" as to management, and no less than "Class VII" as to financial strength, by Best's Insurance Guide, published by A.M. Best Company, Oldwick, New Jersey, or its equivalent, subject to the approval of the County Risk Management Division. Or;
  - b. The company must hold a valid Florida Certificate of Authority as shown in the latest "List of All Insurance Companies Authorized or Approved to Do Business in Florida" issued by the State of Florida Department of Financial Services.

Certificate holder must read: MIAMI-DADE COUNTY, 111 NW 1<sup>st</sup> STREET, SUITE 2340, MIAMI, FL. 33128.

Compliance with the foregoing requirements shall not relieve the Contractor of his liability and obligation under this section or under any other section of this agreement.

## **SECTION 4: SUPPLEMENTAL INFORMATION**

SAMPLE SURETY PERFORMANCE AND PAYMENT BOND

### SURETY PERFORMANCE AND PAYMENT BOND

By this Bond, We \_\_\_\_\_, as Principal, whose principal business address is \_\_\_\_\_, as Contractor under the contract dated \_\_\_\_\_, 20 \_\_\_\_, between Principal and Miami-Dade County for the construction of \_\_\_\_\_ Project No. \_\_\_\_\_ (herein after referred to as "Contract") the terms of which Contract are incorporated by reference in its entirety into this Bond and \_\_\_\_\_, a corporation, whose principal business address is \_\_\_\_\_ as Surety, are bound to Miami-Dade County (hereinafter referred to as "County") in the sum of \_\_\_\_\_ (U.S. dollars) \$ \_\_\_\_\_, for payment of which we bind ourselves, our heirs, personal representatives, successors, and assigns, jointly and severally.

THE CONDITION OF THIS BOND is that if Principal:

1. Performs all the work under the Contract, including but not limited to guarantees, warranties and the curing of latent defects, said Contract being made a part of this bond by reference, and in the times and in the manner prescribed in the Contract, including any and all damages for delay; and
2. Promptly makes payments to all claimants, as defined in Section 255.05(1), Florida Statutes, supplying Principal with labor, materials, or supplies, used directly or indirectly by Principal in the prosecution of the work provided for in the contract; and
3. Pays County all losses, damages, including damages for delay, expenses, costs and attorney's fees, including appellate proceedings, that County sustains because of a default by Principal under the Contract, including but not limited to a failure to honor all guarantees and warranties or to cure latent defects in its work or materials within 5 years after completion of the work under the Contract; and
4. Performs the guarantee of all work and materials furnished under the contract for the time specified in the Contract, including all warranties and curing all latent defects within 5 years after completion of the work under the Contract;

then this bond is void; otherwise it remains in full force.

If no specific periods of warranty are stated in the Contract for any particular item or work, material or equipment, the warranty shall be deemed to be a period of one (1) year from the date of final acceptance by the County. This Bond does not limit the County's ability to pursue suits directly with the Principal seeking damages for latent defects in materials or workmanship, such actions being subject to the limitations found in Section 95.11(3) (c), Florida Statutes.

Any changes in or under the Contract Documents and compliance or noncompliance with any formalities connected with the Contract or the changes does not affect Surety's obligation under this Bond.

**SURETY PERFORMANCE BOND (Cont'd)**

IN WITNESS WHEREOF, the above bounden parties have caused this Bond to be executed by their appropriate officials as of the \_\_\_\_\_ day of \_\_\_\_\_, 20 \_\_.

**SAMPLE ONLY**

CONTRACTOR

\_\_\_\_\_  
(Contractor Name)

BY:

\_\_\_\_\_  
(President) (Managing Partner or Joint Venture)

(SEAL)

COUNTERSIGNED BY RESIDENT  
FLORIDA AGENT OF SURETY:

SURETY:

\_\_\_\_\_

\_\_\_\_\_  
(Copy of Agent's current  
Identification Card as issued by  
State of Florida Insurance Commissioner must be attached) By:

\_\_\_\_\_  
Attorney-in-Fact

(CORPORATE SEAL)

(Power of Attorney must be attached)



## PERMITS

# **ACOE and USCG**



## Venetian Causeway Hurricane Irma Repairs Class I Permit Application: CLI-2020-0352

---

January 14<sup>th</sup>, 2021

Lindsey Precht, Biologist II  
Coastal Resources Section  
Division of Environmental Resources Management (DERM)  
701 NW 1<sup>st</sup> Court, 6<sup>th</sup> Floor  
Miami, Florida 33136-3912  
T 305-372-6567 F 305-732-6407

Re: Class I Permit Application CLI-2020-0352: Miami-Dade County, Department of Transportation and Public Works (Venetian Causeway Bascule Bridges) – Bridge and Fender Repairs located on the Venetian Causeway Bridge Numbers 874459 and 874474 between 25° 47' 23.6" N, 80° 10' 52.8" W and 25° 47' 28.5" N, 80° 09' 07.8" W in Miami and Miami Beach, Miami-Dade County, Florida.

Dear Ms. Lindsey:

Attached you can find emails showing our coordination with the Army Corp of Engineers as well as with the United States Coast Guard.

Sincerely,



Oscar Cruz, P.E.  
Chrome Engineering, Inc. – Authorized Permit Agent

cc: Gabriel Delgado, P.E. – PM, Highway Bridge Engineering. Miami-Dade DTPW (Gabriel.Delgado@miamidade.gov)  
Elia Nunez, P.E. Assistant Director Miami-Dade DTPW Engineering, Planning & Development (Elia.Nunez@miamidade.gov)  
Jonathan Pempek – U.S. Army Corps of Engineers (Jonathan.C.Pempek@usace.army.mil)



# **COORDINATION WITH ACOE**

## Oscar Cruz

---

**From:** Gonzalez, Alberto CIV USARMY CESAJ (US) <Albert.Gonzalez@usace.army.mil>  
**Sent:** Thursday, January 14, 2021 9:04 AM  
**To:** Oscar Cruz  
**Cc:** Delgado, Gabriel (DTPW); Fisher, Ryan (DTPW); Precht, Lindsey (RER)  
**Subject:** RE: CLI-2020-0352 Miami-Dade County Department of Transportation and Public Works (Venetian Bridge Repairs) (MDC 20200094)

Oscar,

Thanks for the information and the explanation of the work. Just to clarify, if the work will be limited to the structures associated with the bridge and the fender system, those repairs do not fall under the Section 10 jurisdiction of the US Army Corps of Engineers and instead is covered by the USCG authority under Section 9 of the Rivers and Harbors Act. I recommend you contact their bridges and waterways section for any approvals that may of may not be needed for the repairs. DERM will not have to issue an SAJ-42 on our behalf for this work.

Thanks,  
Albert

---

**From:** Oscar Cruz <ocruz@chromeeng.com>  
**Sent:** Wednesday, January 13, 2021 7:03 PM  
**To:** Gonzalez, Alberto CIV USARMY CESAJ (US) <Albert.Gonzalez@usace.army.mil>  
**Cc:** Delgado, Gabriel (DTPW) <Gabriel.Delgado@miamidade.gov>; Fisher, Ryan (DTPW) <Ryan.Fisher@miamidade.gov>; Precht, Lindsey (RER) <Lindsey.Precht@miamidade.gov>  
**Subject:** [Non-DoD Source] CLI-2020-0352 Miami-Dade County Department of Transportation and Public Works (Venetian Bridge Repairs) (MDC 20200094)

Hello Albert, I hope you are doing well.

We are currently working on the Venetian Causeway Hurricane Irma Repairs to bridges 874459 and 874474 project for the Miami-Dade Department of Transportation and Public Works. Repair plans are currently under review by DERM for permitting. The overall scope of work includes the repairs of the Fender Systems, Tender House roof, and Generator House roof.

The repairs to the fender systems include the replacement of missing or damaged timber elements impacted by the Hurricane. The intent is to simply bring the fender systems back to their original condition with timber elements including a new handrail. Proposed repair plans do not call to replace any existing concrete piles or to install any additional piles. For your reference, the attached PDF shows a before and after Hurricane Irma comparison.

We would like to confirm with you if an in-water biological assessment is required for DERM to evaluate the applicable JaxBo sheets based on the scope of work.

Also, we wanted to see if it is possible to schedule a pre-permit meeting so that we can explain the scope of work and the expected approach to the fender repair for this project. We would like to discuss specific requirements/constraints such as the use of barges, which would not be required for these repairs.

Please let us know if you are available to meet (Microsoft Teams) this week or the next.



Oscar J. Cruz, P.E.  
Senior Structural Engineer/Principal



CHROME ENGINEERING, INC.  
16650 N. Kendall Drive, Suite 205  
Miami, FL 33196  
Direct: 305.432.6826  
[ocruz@chromeeng.com](mailto:ocruz@chromeeng.com)

Privacy Notice: This electronic mail message, and any attachments, are confidential and are intended for the exclusive use of the addressee(s) and may contain information that is proprietary. If you are not the intended recipient, please immediately contact the sender by telephone, or by email, and destroy all copies of this message. In no event shall this material be read, used, stored, or retained by anyone other than the named addressee(s) without the express written consent of the sender or the named addressee(s).

Privacy Notice: This electronic mail message, and any attachments, are confidential and are intended for the exclusive use of the addressee(s) and may contain information that is proprietary. If you are not the intended recipient, please immediately contact the sender by telephone, or by email, and destroy all copies of this message. In no event shall this material be read, used, stored, or retained by anyone other than the named addressee(s) without the express written consent of the sender or the named addressee(s).



# **COORDINATION WITH USCG**



## Oscar Cruz

---

**From:** Beceiro, Omar CIV <Omar.Beceiro@uscg.mil>  
**Sent:** Wednesday, October 21, 2020 8:00 AM  
**To:** Oscar Cruz  
**Cc:** Delgado, Gabriel (DTPW); Fisher, Ryan (DTPW); Rodriguez-Gonzalez, Samuel LT; Zercher, Jennifer N CIV; Lawrence, Eddie H CIV  
**Subject:** RE: Venetian Causeway Hurricane Irma (Bridge 874459 and 874474) Fender and Tender house repairs

Good morning Oscar,

The proposed repairs will not require a USCG permit. Please let us know in advance of any work that may affect navigation through the channel or if you will need the bridge to deviate from the normal operating schedule.

Kind regards,

Omar Beceiro  
Waterways Management Specialist  
U.S. Coast Guard Sector Miami  
100 Macarthur Causeway  
Miami Beach FL 33139  
(305) 535-4317

---

**From:** Oscar Cruz <ocruz@chromeeng.com>  
**Sent:** Monday, October 19, 2020 2:30 PM  
**To:** Beceiro, Omar CIV <Omar.Beceiro@uscg.mil>  
**Cc:** Delgado, Gabriel (DTPW) <Gabriel.Delgado@miamidade.gov>; Fisher, Ryan (DTPW) <Ryan.Fisher@miamidade.gov>  
**Subject:** [Non-DoD Source] Venetian Causeway Hurricane Irma (Bridge 874459 and 874474) Fender and Tender house repairs

Hello Omar, I hope you are doing well.

We are currently working on the plans for the Venetian Causeway Hurricane Irma repairs to the fender systems for bridges 874459 and 874474.

The scope of work includes the rehabilitation of the existing timber fenders damaged by the Hurricane in kind. Damages being repaired include the catwalk and walers as well as retying broken plastic cables around the existing pile clusters. In addition we are rehabilitating the existing "East Generator" Building with a new roofing system.

We would like to coordinate with you the extent of any permits required from your office. We recently submitted an application Miami-Dade County RER for review.



Attached you can also find 90% plans for the project.

Best regards,

Oscar

**Oscar J. Cruz, P.E.**  
**Senior Structural Engineer/Principal**



**CHROME ENGINEERING, INC.**  
16650 N. Kendall Drive, Suite 205  
Miami, Fl. 33196  
Direct: 305.432.6826  
[ocruz@chromeeng.com](mailto:ocruz@chromeeng.com)

Privacy Notice: This electronic mail message, and any attachments, are confidential and are intended for the exclusive use of the addressee(s) and may contain information that is proprietary. If you are not the intended recipient, please immediately contact the sender by telephone, or by email, and destroy all copies of this message. In no event shall this material be read, used, stored, or retained by anyone other than the named addressee(s) without the express written consent of the sender or the named addressee(s).

**City of Miami**

# City of Miami

ASAEL ACE MARRERO, RA, RID, AIA, ICC  
Building Director

ARTHUR NORIEGA V  
City Manager



December 15, 2020

Lindsey Precht  
Biologist II  
Miami Dade County Division of Resources Management (DERM)  
Coastal Resources Section  
701 N.W. 1st Court, 6th Floor  
Miami, FL 33136

RE: Class I permit application: CLI-2020-0352

Dear Ms. Precht:

This letter serves to inform you that the City of Miami Building Department has received a request for a project on the Venetian Causeway for construction and repair work on the Bascule Bridge fender systems and access ladders, Tender House roof, and Generator House roof (Bridge Nos. 874459 and 874474). Miami-Dade County DERM is requesting that the project apply for Class I Permit application #CLI-2020-0352. Please note that the Building Department has no regulatory authority over bridge repairs and construction work and or related activities at the subject location referenced above. As such, any associated plan review(s) would be exempt from customary required City of Miami approval by this department.

Should you require any further information regarding this matter, please do not hesitate to contact my office at (305) 416-1101.

Sincerely,

Asael Ace Marrero, AIA  
Building Director

# MIAMI BEACH

## PLANNING DEPARTMENT

City of Miami Beach, 1700 Convention Center Drive, Miami Beach, Florida 33139  
Tel: (305) 673-7550, Fax: (305) 673-7559

### LETTER OF NO OBJECTION

January 12, 2021

Lindsey Precht  
Biologist II  
Miami Dade County Division of Resources Management (DERM)  
Coastal Resources Section  
701 N.W. 1st Court, 6th Floor  
Miami, FL 33136

**Subject: Class I permit application: CLI-2020-0352**

Dear Ms. Precht;

Please be advised that Planning Department staff has received a request for the project on the Venetian Causeway for construction and repair work on the bascule bridge fender systems and access ladders, Tender House roof, and Generator House roof (Bridge Nos. 874459 and 874474). Miami-Dade County DERM is requesting the project to apply for Class I Permit application #CLI-2020-0352. We have determined that the proposed work does not violate any applicable zoning ordinances.

Should you have any questions, please do not hesitate to contact the Planning Department.

Sincerely,



Steven Williams  
Chief of Planning Services

# **City of Miami Beach**

# MIAMIBEACH

**City of Miami Beach**, 1700 Convention Center Drive, Miami Beach, FL 33139, [www.miamibeachfl.gov](http://www.miamibeachfl.gov)

Building Department, Administration  
Tel: 305.673.7610, E-mail: [Anasalqueiro@miamibeachfl.gov](mailto:Anasalqueiro@miamibeachfl.gov)

March 9<sup>th</sup>, 2021

RER DERM

Miami Dade County Division of Resources Management (DERM)

Coastal Resources Section

701 N.W. 1st Court, 6th Floor

Miami, FL 33136

RE: Class I permit application: CLI-2020-0352

To Whom it may Concern:

This letter serves to inform you that the Building Department has received a request for the project on the Venetian Causeway for construction and repair work on the Venetian Causeway Bascules (Nos. 874459, 874474) Repairs. Miami-Dade County DERM is requesting the project to apply for Class I Permit application #CLI-2020-0352. The Building Department has no regulatory authority over the bridge repair and construction work and or related activities at the subject location referenced above. As such, any associated plan review(s) would be exempt from customary required City of Miami Beach approval.

Sincerely,

Ana Salgueiro



Ana M. Salgueiro  
Building Department Director

# MIAMIBEACH

3/9/2021 | 9:46 AM EST

# MIAMI BEACH

## PLANNING DEPARTMENT

City of Miami Beach, 1700 Convention Center Drive, Miami Beach, Florida 33139  
Tel: (305) 673-7550, Fax: (305) 673-7559

### LETTER OF NO OBJECTION

January 12, 2021

Lindsey Precht  
Biologist II  
Miami Dade County Division of Resources Management (DERM)  
Coastal Resources Section  
701 N.W. 1st Court, 6th Floor  
Miami, FL 33136

**Subject: Class I permit application: CLI-2020-0352**

Dear Ms. Precht;

Please be advised that Planning Department staff has received a request for the project on the Venetian Causeway for construction and repair work on the bascule bridge fender systems and access ladders, Tender House roof, and Generator House roof (Bridge Nos. 874459 and 874474). Miami-Dade County DERM is requesting the project to apply for Class I Permit application #CLI-2020-0352. We have determined that the proposed work does not violate any applicable zoning ordinances.

Should you have any questions, please do not hesitate to contact the Planning Department.

Sincerely,



Steven Williams  
Chief of Planning Services



# **Miami-Dade RER**



## Class I Construction Permit

**Permit Number:** CLI-2020-0352 **Issue Date:** 12/22/2022 AD  
**DERM Project Manager:** Lindsay Elam **Work Expiration Date:** 12/22/2024 RA

**Permittee**

Miami-Dade County  
 c/o Miami-Dade County, Department of  
 Transportation and Public Works  
 c/o Elia Nuñez, P.E., Assistant Director  
 701 Northwest First Court, Suite 1700  
 Miami, Florida 33136

**Contractor**

See Specific Condition #1.

**Bond**

**Performance Bond:** N/A  
**Mitigation Bond:** N/A  
**BBEETF Contribution:** N/A

**Engineer**

Oscar Javier Cruz, P.E. 63889  
 Chrome Engineering, Inc.  
 Phone No. (305) 432-6826  
  
 Jorge Leon, P.E. #68705  
 STV, Inc.  
 Phone No. (305) 537-4673

**THE ABOVE NAMED PERMITTEE IS HEREBY AUTHORIZED TO PERFORM THE WORK SHOWN ON THE APPLICATION AND APPROVED DRAWINGS, PLANS, AND OTHER DOCUMENTS ATTACHED HERETO OR ON FILE WITH THE DEPARTMENT AND MADE PART HEREOF, SUBJECT TO THE ATTACHED GENERAL AND SPECIFIC CONDITIONS.**

**Plans Entitled:** PLANS FOR PROPOSED IMPROVEMENTS TO VENETIAN CAUSEWAY BRIDGE NO. 874459 AND NO. 874474 HURRICANE IRMA REPAIRS

**Date Signed and Sealed:** 12/04/2020, 03/15/2021

**Project Location:** Venetian Causeway Bridge Numbers 874459 and 874474 between 25° 47' 23.6" N, 80° 10' 52.8" W and 25° 47' 28.5" N, 80° 09' 07.8" W in Miami and Miami Beach, Florida 33139

**Project Description:**

- Removal, repair, and replacement of bridge components, approximately 252 linear feet of removal, repair, and replacement of each of the east and west

**THIS PERMIT AND PLANS SHALL BE KEPT ON SITE DURING ALL PHASES OF CONSTRUCTION**

fender components, including the roof tiles of the existing control house (14.3 feet wide by 22.5 feet long) in the existing footprint as per the DERM final approved plans for Bridge Number 874459.

- Removal, repair, and replacement of bridge components, approximately 250 linear feet of removal, repair, and replacement of each of the east and west fender components, including the roof tiles of the existing control house (12 feet wide by 14.1 feet long) in the existing footprint as per the DERM final approved plans for Bridge Number 874474.
- Installation of utility lines and conduits in accordance with the DERM final approved plans.

*\*The spall and crack repairs of the bridge components are not included in this Class I permit; a Class I permit is not required provided the work is done in accordance with Section 24-48(1)(b) of the Code of Miami-Dade County.*

**THIS PERMIT AND PLANS SHALL BE KEPT ON SITE  
DURING ALL PHASES OF CONSTRUCTION**

## **Specific Conditions**

1. **The name, address, telephone number, and license number of the contractor who will be performing the work must be submitted a minimum of 14 days prior to the commencement the work. Work authorized by this permit shall not commence until written acceptance of the contractor by DERM has been issued.**
2. **All work shall be conducted within the same footprint as the existing structures and shall not extend farther overwater. Work to the existing control houses shall be limited to the footprint of the existing structures, as exceeding the footprint shall be considered expanding non-water dependent structures and would be required to be processed as a Standard Form Class I permit application and be heard before and approved by the Board of County Commissioners.**
3. Please be advised that the federal government may have designated all or part of the subject property as critical habitat for one or more endangered species. You are not authorized to commence any work or activities pursuant to this permit until you obtain any and all approvals or permits, if necessary, from the federal government pursuant to the Endangered Species Act and from the State of Florida pursuant to Florida law on endangered species. Please be advised that, even after work commences, if Miami-Dade County is advised by the federal government, the State of Florida, or a court that an activity on the subject property is in violation of the Endangered Species Act, in violation of Florida law on endangered species, or in violation of a permit or approval granted by the federal government pursuant to the Endangered Species Act, such violation may result in an immediate stop work order. You are strongly advised to consult with the United States Fish and Wildlife Service and any other necessary federal or state agencies before conducting any work or activities on the property. The Vero Beach office of the United States Fish and Wildlife Service may be reached at (772) 562-3909. Please be aware that the federal government may require certain actions or protections on the property, and this may result in the need to modify the plans for the property. Therefore, it is recommended that you consult with the United States Fish and Wildlife Service at an early stage in the process. In the event that the United States Fish and Wildlife Service advises that your plans for the subject property may result in a "take" of endangered or threatened species, you are strongly recommended to inform Miami-Dade County in writing at the earliest stage possible.

See General Permit Conditions.

## **General Permit Conditions**

1. This permit does not eliminate the necessity to obtain any required federal, state, and local authorizations prior to the start of any activity approved by this permit. This permit is a regulatory approval and does not convey to the permittee or create in the permittee any property right or privilege, or any interest in real property, nor does it authorize any entrance upon or activities on property which is not owned or controlled by the permittee. In the event that any structure authorized hereunder is determined by a final adjudication issued by a court of competent jurisdiction to encroach on or interfere with adjacent riparian rights, the permittee agrees to either obtain written consent for the offending structure from the affected riparian owner or to remove the interference.
2. This permit shall be kept on-site during all phases of construction.
3. All work shall be performed in accordance with the above referenced plans and in accordance with the attached specific and general permit conditions. If a General Condition(s) conflicts with a Specific Condition(s) in this permit document, the Specific Condition shall be the controlling condition for work authorized by this permit.
4. This permit only authorizes the work described under the Project Description. Any additional work in, on, over or upon tidal waters or coastal wetlands at the property shall require additional Class I approval.
5. Any deviation from the approved plans for this project shall be submitted in writing to DERM prior to the commencement of work, and work may not commence without written acknowledgement of any deviation by

**THIS PERMIT AND PLANS SHALL BE KEPT ON SITE  
DURING ALL PHASES OF CONSTRUCTION**

DERM. The contractor and the permittee shall take whatever remedial action is necessary to bring the project into compliance with the permit and approved plans upon determination by DERM that the structure is not in compliance with such.

6. DERM shall be notified no later than 48 hours and no earlier than 5 days prior to the commencement of the work authorized by this permit, unless otherwise noted herein. The permittee and/or contractor may notify DERM by calling (305) 372-6575 or by submitting the attached Notice of Commencement of Construction via hand delivery, U.S. Mail, or email at [dermcr@miamidade.gov](mailto:dermcr@miamidade.gov).
7. Prior to performing any work, the contractor shall verify the location of all underground and overhead utility lines and verify that no utilities will be damaged by the work. Contact Sunshine State One-Call of Florida at 1-800-432-4770 or on the web at <http://www.callsunshine.com/corp/before/submitting.html> for locating underground utility lines.
8. The permittee and the contractor are hereby advised that under Florida law, no person shall commence any excavation, filling, construction, or other activity involving the use of sovereign or other lands of the State, title to which is vested in the Board of Trustees of the Internal Improvement Trust Fund or the Florida Department of Environmental Protection (FDEP), until such person has received the required authorization for the proposed use from the Board of Trustees or FDEP. If such work is done without consent, or if a person otherwise damages state land or products of state land, the Board of Trustees may levy administrative fines of up to \$10,000 per offense pursuant to the Florida Administrative Code.
9. The permittee and contractor shall obtain all required approvals from all local, state and federal agencies prior to performing the work authorized by this permit.
10. Trimming or alteration of mangroves or work in wetlands other than what is authorized by this permit is prohibited. Work not authorized by this permit or that is not explicitly exempt from permit requirements pursuant to the Mangrove Trimming and Preservation Act (403.9321-9334 F.S.) shall require additional Class I approval.
11. For any work involving mangrove trimming or alteration, if the subject Class I permit is revoked by DERM, or the state statute providing the exemption is modified or eliminated, the permittee shall be required to obtain a new permit from DERM prior to mangrove trimming or alteration.
12. All work authorized by this permit shall be performed by the contractor and/or subcontractor holding an applicable certificate of competency and shall be licensed in Miami-Dade County or the State of Florida to perform such work. Any work which is subcontracted shall require that the permittee and contractor (i.e. the contractor who is listed on this permit) notify the project manager at DERM at (305) 372-6575 or by email at [dermcr@miamidade.gov](mailto:dermcr@miamidade.gov) a minimum of 72 hours prior to the subcontractor performing any work. Notification shall include the name of the subcontractor performing the work, the subcontractor's Miami-Dade County license number or state general contractor license number, and scope of work. Failure to comply with this condition is a violation of the Class I permit and may result in enforcement action DERM.
13. The contractor shall not store or place, even on a temporary basis, construction or demolition debris in tidal waters or wetlands and shall take all necessary precautions to prevent construction or demolition debris from falling into the water or adjacent wetlands. Any debris that falls into the water and/or adjacent wetlands shall be removed immediately. Construction and demolition debris shall be disposed of in accordance with all federal, state and local regulations.
14. Turbidity controls (including but not limited to turbidity curtains) shall be implemented whenever visible plumes are present to ensure compliance with the water quality standards stipulated in Section 24-42(3) of the Code of Miami-Dade County. Turbidity controls shall be employed and maintained around the location where work is actively occurring in the most effective manner possible to prevent turbidity from extending beyond the control mechanism in place.
15. Turbidity may not exceed 0 Nephelometric Turbidity Units (NTU) within the Aquatic Preserve or 29 NTU outside of the Aquatic Preserve, above background beyond the turbidity control device or 50 feet from any point of discharge. Turbidity levels shall be monitored. If the turbidity levels exceed the above standards, all construction

**THIS PERMIT AND PLANS SHALL BE KEPT ON SITE  
DURING ALL PHASES OF CONSTRUCTION**

shall stop and additional turbidity controls shall be implemented. Work shall not resume until the contractor has implemented adequate turbidity control methods and has received authorization from DERM to recommence work. At DERM's discretion, turbidity samples may be required to be collected in accordance with Section 24-44.2(3) of the Code of Miami-Dade County.

16. Environmental controls and best management practices shall be implemented to prevent any materials related to construction from entering the surrounding water. Any material removed as well as material applied to accomplish repairs must be contained so as to prevent fugitive particulates and/or discharge to surface waters. Any materials which fall into the water shall be removed immediately. The contractor shall ensure that no material is placed in the water either temporarily or permanently.
17. If any work or activity associated with this project is to take place in navigable waters, the contractor shall instruct all personnel associated with the project of the potential presence of manatees and the need to avoid collision with manatees. All vessels associated with the project must operate at "Idle Speed/No Wake" at all times while in water where the draft of the vessel provides less than a 4 foot clearance from the bottom. Additionally, all vessels will follow routes of deep water whenever possible. All in-water construction activities shall cease upon the sighting of a manatee(s) within 50 feet of the project area and will not resume until the manatee(s) has departed the project area. Any collision with and/or injury to a manatee shall be reported immediately to the "Manatee Hotline" (1-888-404-FWCC), the U.S. Fish and Wildlife Service, Jacksonville Field Office (904) 791-2580, and DERM (305) 372-6864.
18. The contractor shall ensure that all vessels associated with the construction shall operate within waters of sufficient depth so as to preclude bottom scouring or prop dredging and shall maintain a minimum of 1 foot of water between the vessel bottom and submerged aquatic resources.
19. The contractor shall ensure that there are no impacts to seagrass, hard corals, or soft corals as a result of construction operations, such as, but not limited to, propeller scouring; and vessel or barge anchoring, grounding or spudding. The marine contractor and permittee shall be held jointly liable for any of these unauthorized impacts. For any impacts caused by the construction operation, DERM shall require, at a minimum, restoration and mitigation.
20. For the purposes of this permit, "vessel" is herein defined as any craft designed to float or navigate on water, including but not limited to: sailboats, powerboats, rowboats, boats, ships, skiffs, houseboats, personal watercraft and inflatable boats.
21. Pursuant to Section 24-48.10 of the Code of Miami-Dade County the work or structures authorized under this permit shall be privately maintained by the permittee, his successors and assigns. Whenever, in the opinion of the Director of the DERM, said work or structures are not maintained in such a manner so as to prevent deterioration to the extent that they become a hazard to the public or to navigation, or create an obstruction of flow, or prevent access for drainage maintenance purposes, or may damage adjacent property, then the owner is required to perform any necessary remedial work.
22. Unless otherwise authorized in this permit and pursuant to Sections 24-48.23 and 24-48.24 of the Code of Miami-Dade County, the installation or construction of non-water-dependent floating or fixed structures (e.g. covered structures, canopies, helicopter pads, commercial signs, etc.) is prohibited in, on, over or upon any of the tidal waters of Miami-Dade County and constitutes a violation of this permit. Failure to comply with this condition may subject the permittee to enforcement action without further warning.
23. A DERM Class II permit is required for the construction, installation, and/or alteration of any outfall or overflow system in, on, under or upon any water body of Miami-Dade County. In addition, a DERM Class V permit is required for any dewatering of groundwater, surface waters or water, which has entered into an excavation. The contractor shall contact the Water Control Section of DERM at (305) 372-6681 in order to obtain a Class II or Class V permit prior to the construction of any outfall or overflow system and prior to any dewatering activity.
24. The time allotted to complete the work for which this permit has been issued shall be limited to the period stipulated on the permit unless an extension of time is granted pursuant to Section 24-48.9(2) of the Code of Miami-Dade County. Applications for extensions of time shall be submitted to DERM at least 30 days prior to the

**THIS PERMIT AND PLANS SHALL BE KEPT ON SITE  
DURING ALL PHASES OF CONSTRUCTION**

date of permit expiration; incomplete or untimely applications for extensions of time will be returned to the permittee.

25. An application for Transfer of a Class I permit may be filed with DERM at any time prior to the transfer of property ownership up to 120 days after the date of transfer of fee simple ownership of the property that is the subject of the permit. The Application for Transfer must be signed by both the transferee and transferor. Applications for Transfer shall be filed in the form prescribed by DERM and shall not be processed if the filed Application for Transfer is not fully complete in all respects pursuant to Section 24-48.18, of the Code of Miami-Dade County within 120 days of the date of transfer of property ownership.
26. If the project involves construction, replacement, or repair of a seawall, the new seawall cap shall be a minimum of 6 inches above the final grade of the uplands immediately adjacent, and in order to prevent positive drainage of stormwater into the waterway, all uplands immediately adjacent to the new seawall shall be graded away from the waterway.
27. To further reduce the possibility of injuring or killing a manatee during construction, work within portions of the Biscayne Canal, Little River, and the Coral Gables Waterway shall be performed only between May 1 and November 15.
28. A minimum of 1 foot of clearance shall be maintained at all times between the submerged bottom, and any existing benthic resources, and any vessels moored at the property.
29. Adequate clearance shall be maintained at all times between the submerged bottom, and any existing benthic resources, and any vessels moored at the property, such that there are no impacts to State or County water quality standards, even on a temporary basis, or to benthic resources or the submerged bottom, including but not limited to bottom scouring or prop dredging.
30. If railing is required to be installed pursuant to this permit, it shall be installed within 30 days of completion of the permitted work, and prior to the use of the structure(s) authorized by this permit, including the mooring of vessels.
31. A performance and/or mitigation bond may be held to ensure compliance with the aforementioned conditions and the completion of any required mitigation. Failure to comply with any of these conditions may result in the revocation by Miami-Dade County of all or a portion of the bond without further notice.
32. Pursuant to Section 24-48.3.(9), the use or installation of unencapsulated polystyrene as defined in Section 24-5 shall be prohibited in connection with any work requiring a Class I permit. Pursuant to Section 24-48.26, for all facilities which are subject to a County marine facilities operating permit pursuant to this chapter, such permit shall require the removal, replacement or repair of any unencapsulated polystyrene where such polystyrene shows evidence of degradation, disintegration, shredding, or other damage, as determined in the discretion of the Director.

**THIS PERMIT AND PLANS SHALL BE KEPT ON SITE  
DURING ALL PHASES OF CONSTRUCTION**



DEPARTMENT OF REGULATORY AND ECONOMIC RESOURCES  
COASTAL RESOURCES SECTION  
701 NW 1<sup>st</sup> Court, Ste 600, Miami, FL 33136  
Phone 305-372-6575 Email [dermcr@miamidade.gov](mailto:dermcr@miamidade.gov)

**NOTICE OF COMMENCEMENT OF CONSTRUCTION**

**PERMIT NO.:** \_\_\_\_\_

**PERMITTEE'S NAME:** \_\_\_\_\_

**PROJECT LOCATION:** \_\_\_\_\_

**PERMIT ISSUANCE DATE:** \_\_\_\_\_

**CONTRACTOR NAME:** \_\_\_\_\_

**PROPOSED DATE OF COMMENCEMENT:** \_\_\_\_\_

**ANTICIPATED DATE OF COMPLETION:** \_\_\_\_\_

**COMMENTS:** \_\_\_\_\_

\_\_\_\_\_  
\_\_\_\_\_  
\_\_\_\_\_  
\_\_\_\_\_  
\_\_\_\_\_  
\_\_\_\_\_  
\_\_\_\_\_  
\_\_\_\_\_  
\_\_\_\_\_  
\_\_\_\_\_  
\_\_\_\_\_  
\_\_\_\_\_  
\_\_\_\_\_  
\_\_\_\_\_

**THIS PERMIT AND PLANS SHALL BE KEPT ON SITE  
DURING ALL PHASES OF CONSTRUCTION**



# City of Miami

ASAEL ACE MARRERO, RA, RID, AIA, ICC  
Building Director

ARTHUR NORIEGA V  
City Manager



December 15, 2020

Lindsey Precht  
Biologist II  
Miami Dade County Division of Resources Management (DERM)  
Coastal Resources Section  
701 N.W. 1st Court, 6th Floor  
Miami, FL 33136

RE: Class I permit application: CLI-2020-0352

Dear Ms. Precht:

This letter serves to inform you that the City of Miami Building Department has received a request for a project on the Venetian Causeway for construction and repair work on the Bascule Bridge fender systems and access ladders, Tender House roof, and Generator House roof (Bridge Nos. 874459 and 874474). Miami-Dade County DERM is requesting that the project apply for Class I Permit application #CLI-2020-0352. Please note that the Building Department has no regulatory authority over bridge repairs and construction work and or related activities at the subject location referenced above. As such, any associated plan review(s) would be exempt from customary required City of Miami approval by this department.

Should you require any further information regarding this matter, please do not hesitate to contact my office at (305) 416-1101.

Sincerely,

  
Asael Ace Marrero, AIA  
Building Director

PLANS FOR PROPOSED  
IMPROVEMENTS TO

# VENETIAN CAUSEWAY BRIDGE NO. 874459 AND NO. 874474 HURRICANE IRMA REPAIRS

BRIDGES 874459 AND 874474 MIAMI-DADE  
COUNTY PROJECT NO. EDP-MT-20200094  
VENETIAN CAUSEWAY MAINTENANCE

**NOTE:**

ATTENTION IS DIRECTED TO THE FACT THAT THESE PLANS MAY HAVE BEEN REDUCED IN SIZE BY REPRODUCTION. THIS MUST BE CONSIDERED WHEN OBTAINING SCALED DATA.

SHT. No.	SHEET DESCRIPTION
B-00	COVER SHEET
B-01	SUMMARY OF PAY ITEMS
B-02	GENERAL NOTES 1 OF 3
B-03	GENERAL NOTES 2 OF 3
B-04	GENERAL NOTES 3 OF 3
B-05	PLAN AND ELEVATION BRIDGE 874459
B-06	FENDER SYSTEM PLAN VIEW BRIDGE 874459
B-07	PLAN AND ELEVATION BRIDGE 874474
B-08	FENDER SYSTEM PLAN VIEW BRIDGE 874474
B-09	FENDER SYSTEM DETAILS 1 OF 2
B-10	FENDER SYSTEM DETAILS 2 OF 2
B-11	STRUCTURAL TREATED TIMBER BILL OF MATERIALS 1 OF 2
B-12	STRUCTURAL TREATED TIMBER BILL OF MATERIALS 2 OF 2
B-13	LADDER AND PLATFORM DETAILS
B-14	GENERATOR BUILDING REPAIR DETAILS
B-15	REPAIR DETAILS
BE-01	SYMBOLS ABBREVIATIONS AND NOTES
BE-02	PLAN AND ELEVATION BRIDGE 874459
BE-03	BRIDGE CONDUIT DIAGRAM BRIDGE 874459
BE-04	PLAN AND ELEVATION BRIDGE 874474
BE-05	BRIDGE CONDUIT DIAGRAM BRIDGE 874474
BE-06	NAVIGATION LIGHT DETAILS

BRIDGE No. 874459  
WEST VENETIAN CAUSEWAY

BRIDGE No. 874474  
EAST VENETIAN CAUSEWAY

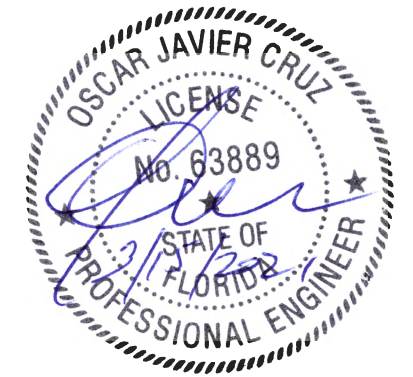
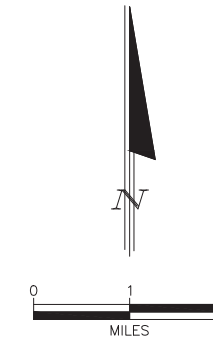
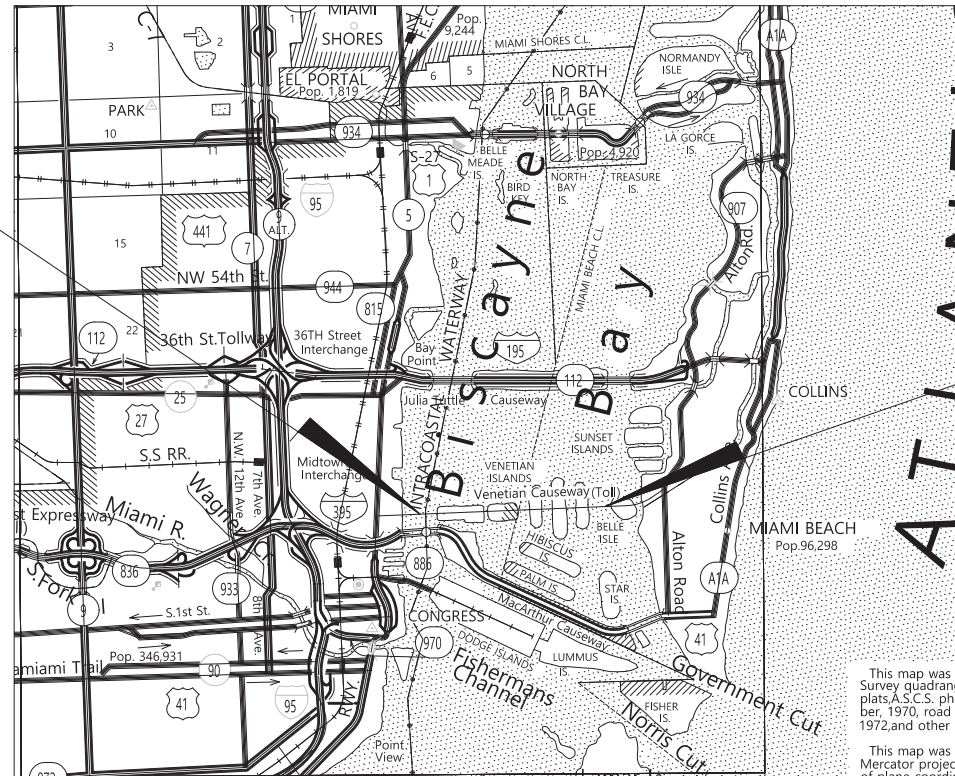

**RER - NATURAL RESOURCES DIVISION  
PRELIMINARY APPROVAL**

NAME Micaela Soldi  
DATE 04/12/2021

**RER - NATURAL RESOURCES DIVISION  
FINAL APPROVAL**

NAME Ashley Dominguez  
DATE 12/22/2022

	LENGTH OF JOB	
	LIN. FT.	MILES
BRIDGE	-	-
GROSS LENGTH OF JOB	-	-
EXCEPTIONS	-	-
NET LENGTH OF JOB	-	-

PREPARED FOR



MIAMI-DADE COUNTY  
DEPARTMENT OF TRANSPORTATION AND PUBLIC WORKS  
HIGHWAY DIVISION

STEPHEN P. CLARK CENTER  
701 NW 1 COURT  
MIAMI, FLORIDA 33136

BY

ENGINEER OF RECORD:

OSCAR J. CRUZ  
FLORIDA REGISTRATION P.E. No. 63889



STV INCORPORATED  
6303 BLUE LAGOON DR. SUITE 400  
MIAMI FL, 33126  
(305)537-4673 FAX: (305)751-5311

ENGINEER OF RECORD:

JORGE LEON  
FLORIDA REGISTRATION P.E. No. 68705

THESE PLANS HAVE BEEN PREPARED IN ACCORDANCE WITH AND ARE GOVERNED BY THE MIAMI-DADE COUNTY PUBLIC WORKS DEPARTMENT STANDARDS AND SPECIFICATIONS PARTS 1, 2 AND 3. THE MANUAL OF UNIFORM MINIMUM STANDARDS FOR DESIGN, CONSTRUCTION AND MAINTENANCE FOR STREETS AND HIGHWAYS. THE FLORIDA DEPARTMENT OF TRANSPORTATION ROADWAY AND TRAFFIC DESIGN STANDARDS, AND THE FLORIDA DEPARTMENT OF TRANSPORTATION STANDARD SPECIFICATIONS, AS AMENDED BY CONTRACT DOCUMENTS.



CHROME ENGINEERING, INC.  
16650 N. KENDALL DR., SUITE 205  
MIAMI FL, 33196  
(305) 432-6826

APPROVED	_____	COUNTY ENGINEER
RECOMMENDED	_____	ASSISTANT DIRECTOR
SUBMITTED	_____	HIGHWAY DIVISION
PROPOSED	_____	CHECK
DESIGN	_____	DRAWN
DATE	_____	SHEET B-00 OF B-15

DADE COUNTY DEPARTMENT OF TRANSPORTATION AND PUBLIC WORKS						
LEAD PROJECT: 20200094				COUNTY/SECTION :		
PROJECT(S):				COUNTY : MIAMI-DADE		
SUMMARY OF PAY ITEMS						
PAY ITEM NO.	PAY ITEM DESCRIPTION	UNIT	QUANTITY			
			874459	874474	EGB	TOTAL
101-1-A	MOBILIZATION	LS	1	1	1	3
104-11A	FLOATING TURBIDITY BARRIER	LF	1,000	1,000	0	2,000
110-82	REMOVE & DISPOSE OF STRUCTURAL TIMBER	MB	4.8	4.8	0	9.6
401-70-2	RESTORE SPALLED AREAS, LATEX MODIFIED MORTAR STYRENE-BUTADINE	CF	4.0	11.7	16.5	32.2
455-76	WRAP PILE CLUSTERS	EA	3	2	0	5
460-6-1	LADDERS & PLATFORMS, NEW CONSTRUCTION	LS	1	1	0	2
470-1	TREATED TIMBER, STRUCTURAL	MB	8.0	8.8	0	16.8
510-1	NAVIGATION LIGHTS- FIXED BRIDGE, SYSTEM	LS	1	1	0	2
510-1-2	ELECTRICAL SYSTEM (REMOVAL)(EXISTING FIXED BRIDGE NAVAGATIONAL LIGHTS)	LS	1	1	0	2
750-1-59	ARCHITECTUAL - BUILDING, REHAB	SF	321	172	144	637
751-7	ARCHITECTUAL - ROOF REPAIRS	LS	0	0	1	1

NOTE:  
BRIDGE 874459 (WEST BRIDGE)  
BRIDGE 874474 (EAST BRIDGE)  
EGB = EAST GENERATOR BUILDING

**RER - NATURAL RESOURCES DIVISION  
PRELIMINARY APPROVAL**  
NAME Micaela Soldi  
DATE 04/12/2021

**RER - NATURAL RESOURCES DIVISION  
FINAL APPROVAL**  
NAME Ashley Dominguez  
DATE 12/22/2022



BRIDGE NO. 874459, 874474

REVISIONS					
DATE	BY	DESCRIPTION	DATE	BY	DESCRIPTION



CHROME ENGINEERING, INC.  
16650 N. KENDALL DR., SUITE 205  
MIAMI FL, 33196  
(305) 432-6826  
OSCAR J. CRUZ, P.E. LICENSE # 63889

DESIGNED BY	NAME	DATE	DRAWN BY	NAME	DATE
JAC	JAC	06/22/2020	ML	ML	08/25/2020
CHECKED BY	NAME	DATE	CHECKED BY	NAME	DATE
OC	OC	11/05/2020	OC	OC	11/05/2020



TRANSPORTATION & PUBLIC WORKS DTPW  
701 NW 1ST COURT  
MIAMI, FLORIDA 33136

B-01 SUMMARY OF PAY ITEMS

**GENERAL SPECIFICATIONS:**

FLORIDA DEPARTMENT OF TRANSPORTATION STANDARDS FOR ROAD AND BRIDGE CONSTRUCTION (DATED JANUARY 2020), AS AMENDED BY CONTRACT DOCUMENTS.

**DESIGN SPECIFICATIONS:**

JANUARY 2020 EDITION OF THE FDOT STRUCTURES MANUAL UNLESS OTHERWISE NOTED. AMERICAN ASSOCIATION OF STATE HIGHWAY AND TRANSPORTATION OFFICIALS (AASHTO) LRFD BRIDGE DESIGN SPECIFICATIONS (8TH EDITION) AND ALL SUBSEQUENT INTERIMS.

**ENVIRONMENT:**

SUPERSTRUCTURE: EXTREMELY AGGRESSIVE – COASTAL  
SUBSTRUCTURE: EXTREMELY AGGRESSIVE – COASTAL

**SURVEY:**

ALL PUBLIC LAND CORNERS AND PRIMARY NETWORK CONTROL SURVEY MONUMENTS ARE TO BE PROTECTED BY THE CONTRACTOR. CORNERS AND MONUMENTS WITHIN THE WORK ZONE AND IN DANGER OF BEING DAMAGED, DESTROYED OR COVERED SHALL BE PROPERLY REFERENCED BY A REGISTERED LAND SURVEYOR IN ACCORDANCE WITH THE MINIMUM TECHNICAL STANDARDS OF THE FLORIDA BOARD OF PROFESSIONAL LAND SURVEYORS PRIOR TO THE BEGINNING OF WORK INCLUDE ALL COST OF REFERENCING AMONG THE VARIOUS SCHEDULED ITEMS ON THE CONTRACT.

**UTILITIES:**

ALL EXISTING UTILITIES ARE TO REMAIN UNLESS OTHERWISE NOTED.

THE CONTRACTOR IS ADVISED THAT PROPERTIES ADJACENT TO THE PROJECT HAVE ELECTRIC, TELEPHONE, GAS, WATER AND/OR SEWER SERVICE LATERALS WHICH MAY NOT BE SHOWN IN PLANS. THE CONTRACTOR MUST REQUEST THE LOCATION OF THESE LATERAL SERVICES THE UTILITY COMPANIES. THE ADDITIONAL COST OF EXCAVATING, INSTALLING, BACKFILLING AND COMPACTING AROUND THESE LATERAL MUST BE INCLUDED IN THE BID RELATED ITEM FOR THE WORK BEING DONE.

FOR THE LIST OF UTILITY OWNERS, PLEASE REFER TO GENERAL NOTES SHEET B-03.

**REINFORCED CONCRETE REPAIR MATERIALS:**

MATERIALS UTILIZED FOR REPAIRS TO THE REINFORCED CONCRETE EXISTING STRUCTURE SHALL BE IN ACCORDANCE WITH PROVIDED TECHNICAL SPECIAL PROVISION FOR CONCRETE REPAIRS.

**REINFORCING STEEL:**

ALL REINFORCING STEEL SHALL BE ASTM A615, GRADE 60.

**STRUCTURAL STEEL:**

ALL STRUCTURAL STEEL SHALL BE ASTM A709, GRADE 36, UNLESS NOTED OTHERWISE.

**PLAN DIMENSIONS:**

THE CONTRACTOR'S ATTENTION IS DIRECTED TO THE FACT THAT, DUE TO THE NATURE OF REHABILITATION/REPAIR PROJECTS, THE EXACT EXTENT OF REHABILITATION/REPAIR WORK CANNOT ALWAYS BE ACCURATELY DETERMINED PRIOR TO THE COMMENCEMENT OF WORK. THESE PLANS WERE DETAILED TO AGREE WITH THE EXISTING PLANS AND THE RESULTS OF A LIMITED FIELD INVESTIGATION. THE CONTRACTOR SHALL FIELD VERIFY PLAN DIMENSIONS AND ELEVATIONS PRIOR TO START OF WORK.

THE DETAILS ON THE DRAWINGS INDICATE THE LIMITS OF REMOVAL AND REPAIR BASED ON THE FIELD OBSERVATIONS PERFORMED ON JUNE 16, 2020 AND JULY 7, 2020. THE REMOVAL AND REPAIR UNITS SHOWN ON THE CONTRACT DRAWINGS INDICATE APPROXIMATE REMOVAL AND REPAIR LIMITS BASED ON THE CONDITION OF THE STRUCTURE AT THE TIME OF THE INSPECTIONS.

THE CONTRACTOR SHALL TAKE ALL SUCH FIELD MEASUREMENTS AS ARE NECESSARY TO ENSURE PROPER FIT OF THE FINISHED WORK, AND THE CONTRACTOR SHALL ASSUME FULL RESPONSIBILITY FOR THEIR ACCURACY. WHEN SHOP DRAWINGS BASED ON FIELD MEASUREMENTS ARE SUBMITTED FOR APPROVAL, THE FIELD MEASUREMENTS MADE SHALL BE INCLUDED IN THE SHOP DRAWINGS AND SUBMITTED TO THE ENGINEER. THE CONTRACTOR SHALL USE AN ASTERISK (\*) OR SIMILAR MEANS TO INDICATE A FIELD MEASUREMENT ON SHOP DRAWINGS.

**NAVIGATION:**

THE WATERS WITHIN THE PROJECT AREA ARE FREQUENTED BY BOAT TRAFFIC. THE CONTRACTOR SHALL NOTIFY THE UNITED STATES COAST GUARD MARINE COORDINATOR SAFETY OFFICE SIXTY (60) DAYS PRIOR TO BEGINNING CONSTRUCTION AND SUBMIT A PLAN FOR CLEARING THE CHANNEL IN THE EVENT OF HURRICANE WATCH/WARNING. AT NO TIME DURING THE CONSTRUCTION, SHALL THE WATERWAY BE CLOSED TO NAVIGATION.

**EXISTING BRIDGE PLANS:**

FOR ADDITIONAL DETAILS OF THE BRIDGE, SEE EXISTING BRIDGE PLANS. UNLESS OTHERWISE NOTED, THE DIMENSIONS, ELEVATIONS AND INTERSECTING ANGLES SHOWN ARE BASED ON THE INFORMATION AS DETAILED IN THE ORIGINAL CONSTRUCTION PLANS OF THE EXISTING BRIDGE AND MAY NOT REPRESENT AS-BUILT CONDITIONS.

**SITE INSPECTION:**

THE CONTRACTOR SHALL VISIT THE SITE BEFORE BIDDING TO BECOME FAMILIARIZED WITH THE PRESENT CONDITION AND TO JUDGE THE EXTENT AND NATURE OF THE WORK TO BE DONE UNDER THIS CONTRACT. NO EXTRA COMPENSATION WILL BE ALLOWED BECAUSE OF FAILURE TO INCLUDE IN BID ALL ITEMS AND MATERIALS WHICH ARE REQUIRED TO BE FURNISHED IN ACCORDANCE WITH THE CONTRACT DOCUMENTS.

**WATER QUALITY:**

CONTRACTOR WILL BE RESPONSIBLE TO ADHERE TO ALL CLASS I PERMIT REQUIREMENTS FROM DERM BEFORE BEGINNING WORK. THIS PROJECT IS ON THE INTRACOASTAL WATERWAY, WHICH IS DESIGNATED AS OUTSTANDING FLORIDA WATERS. NO DEGRADATION OF WATER QUALITY AND/OR INCREASED TURBIDITY OF THE WATER AND/OR THE DISCHARGE OF ANY FOREIGN MATERIAL INTO THE WATER SHALL BE PERMITTED. THE CONTRACTOR WILL BE RESPONSIBLE FOR PREVENTING THE DISCHARGE OF ANY FOREIGN MATERIAL INTO THE WATER. THE CONTRACTOR SHALL ERECT THE BEST AVAILABLE MEANS OF EROSION AND TURBIDITY CONTROL MEASURES TO ISOLATE THE WORK AREA AT ALL TIMES. THE CONTRACTOR SHALL MAINTAIN APPROPRIATE SKIMMERS AND ABSORBENT MATERIALS AT THE WORK AREA FOR IMMEDIATE DEPLOYMENT IN THE EVENT OF AN ACCIDENTAL SPILL, THE COST SHALL BE INCLUDED IN PAY ITEM 104-11-A FLOATING TURBIDITY BARRIER.

**ENVIRONMENTAL NOTES:**

1. THE FOLLOWING FEDERALLY AND STATE LISTED ANIMAL SPECIES COULD INHABIT OR MIGRATE THROUGH THE CONSTRUCTION AREA: WEST INDIAN MANATEE AND SEA TURTLES. THE CONTRACTOR SHALL COMPLY WITH ALL FEDERAL AND STATE REQUIREMENTS REGARDING ENDANGERED AND THREATENED SPECIES AND STATE LISTED SPECIES OF SPECIAL CONCERN. SHOULD THESE SPECIES BE ENCOUNTERED; THE CONTRACTOR SHALL CONTACT THE MIAMI-DADE COUNTY ENVIRONMENTAL OFFICE WITHIN 24 HOURS OF EACH ENCOUNTER.
2. SEAGRASS BEDS AND OTHER BENTHIC COMMUNITIES EXIST IN THE PROJECT AREA. THE CONTRACTOR SHALL PREVENT CONTACT WITH THE SEABED IN THESE AREAS AND ANY DISTURBANCE OF BOTTOM SEDIMENTS (E.G., FROM MOVING OR ANCHORING BARGES AND OTHER STRUCTURES). THE CONTRACTOR SHALL NOT SHADE ANY BENTHIC COMMUNITY FROM DIRECT SUNLIGHT FOR MORE THAN TWO WEEKS. ANCHORING LOCATIONS SHALL BE APPROVED BY THE ENGINEER WHO SHALL COORDINATE WITH THE MIAMI-DADE COUNTY ENVIRONMENTAL PERMITS COORDINATOR.
3. THE CONTRACTOR SHALL REVIEW ENVIRONMENTAL REQUIREMENTS OF ANY PROPOSED STAGING AREAS WITH MIAMI-DADE COUNTY DEPARTMENT OF TRANSPORTATION AND PUBLIC WORKS AT LEAST SEVENTY TWO (72) HOURS PRIOR TO USE.
4. THE STAGING AREA SHALL NOT BE WITHIN THE LIMITS OF THE WETLANDS.
5. ANY MATERIAL TO BE STOCKPILED FOR PERIODS GREATER THAN 24 HOURS SHALL BE PROTECTED BY APPROPRIATE EROSION CONTROL DEVICES AT NO ADDITIONAL COMPENSATION.
6. TIMBER FROM THE EXISTING FENDER SYSTEM HAS BEEN TREATED IN THE PAST WITH PRESERVATIVES AND SHALL BE CONSIDERED SPECIAL WASTE FOR DISPOSAL PURPOSES. THE CONTRACTOR SHALL PLACE THE TIMBERS ON A DRY IMPERVIOUS SURFACE. THE CONTRACTOR SHALL ADHERE TO DTPW CONSTRUCTION SPECS 110, D, 2.

**CONSTRUCTION NOTES:**

1. THE CONTRACTOR SHALL PROVIDE SAFE ACCESS FOR THE ENGINEER AT ALL TIMES FOR HIS INSPECTION OF THE PROJECT. THIS INCLUDES (BUT IS NOT LIMITED TO) SCAFFOLDING, AND/OR INSPECTION BOAT WITH OPERATOR REMAINING IN PLACE UNTIL THE ENGINEER CAN PERFORM ALL NECESSARY INSPECTIONS AMONG THE VARIOUS SCHEDULED ITEMS ON THE CONTRACT.
2. ALL SALVAGEABLE MATERIALS THAT ARE TO BE REMOVED MUST BE DELIVERED AND UNLOADED AT THE MIAMI-DADE ROAD, BRIDGE AND CANAL MAINTENANCE DIVISION, 9301 NW 58TH STREET, MIAMI FL. 33178 TELEPHONE NO. (305) 592-3116.
3. CONTRACTOR SHALL BE RESPONSIBLE TO RESTORE TO EXISTING CONDITION ALL SIGNING AND MARKING DISTURBED DURING CONSTRUCTION.

**SCOPE OF WORK:**

THE PRIMARY TASKS TO BE COMPLETED BY THE CONTRACTOR ARE AS FOLLOWS:

1. REMOVE THE EXISTING DAMAGED TIMBER FENDER SYSTEM COMPONENTS INCLUDING, WALES, SPACER BLOCKS, CATWALK PLANKS, DECK SUPPORTS, ALL ASSOCIATED CONNECTIONS AND WIRE ROPES. INSTALL NEW WALES, SPACER BLOCKS, CATWALK PLANKS, DECK SUPPORTS, WIRE ROPES AND HANDRAIL IN ACCORDANCE WITH SHEETS B-06 THRU B-10.
2. REMOVE AND REPLACE FENDER NAVIGATIONAL LIGHT SYSTEM IN ACCORDANCE WITH SHEETS BE-01 THRU BE-06.
3. REMOVE AND REPLACE EXISTING DAMAGED LADDERS PLATFORMS IN ACCORDANCE WITH SHEET B-05, B-07 AND B-13.
4. REMOVE AND REPLACE ROOF TILES AT BOTH BRIDGE TENDER HOUSES AND THE ROOF MATERIALS AT THE EAST BRIDGE GENERATOR BUILDING IN ACCORDANCE WITH SHEETS B-05, B-07, B-14 AND B-15.
5. REPAIR SPALLS WITH EXPOSED REINFORCING AT EXISTING FENDER CONCRETE PILES, AND REPAIR CONCRETE DECK SLAB SPALLS AT EAST BRIDGE GENERATOR BUILDING IN ACCORDANCE WITH SHEETS B-14 AND B-15.
6. REPAIR EXISTING WALLS, REPAIR EXISTING ROOF DECK, CLEAN AND PAINT THE EXTERIOR WALLS AND STEEL GATE AT THE EAST GENERATOR BUILDING.

**RER - NATURAL RESOURCES DIVISION  
FINAL APPROVAL**  
NAME Ashley Dominguez  
DATE 12/22/2022

**RER - NATURAL RESOURCES DIVISION  
PRELIMINARY APPROVAL**  
NAME Micaela Soldi  
DATE 04/12/2021



BRIDGE NO. 874459, 874474

C:\Users\mlemus\chromeeng.com\Chrome Engineering - Projects\20-13\700\_CA00D\B2-B4-General Notes.dwg Mar 15, 2021 - 12:41 pm MLEMUS

REVISIONS							
DATE	BY	DESCRIPTION	DATE	BY	DESCRIPTION	DATE	BY



CHROME ENGINEERING, INC.  
16650 N. KENDALL DR., SUITE 205  
MIAMI FL, 33196  
(305) 432-6826  
OSCAR J. CRUZ, P.E. LICENSE # 63889

DESIGNED BY	NAME	DATE	DRAWN BY	NAME	DATE
JAC	JAC	06/22/2020	ML	ML	08/25/2020
OC	OC	11/05/2020	OC	OC	11/05/2020



TRANSPORTATION & PUBLIC WORKS DTPW  
701 NW 1ST COURT  
MIAMI, FLORIDA 33136

B-02

GENERAL NOTES  
1 OF 3

**ELECTRICAL NOTES:**  
 REFER TO SHEET BE-01 FOR ELECTRICAL GENERAL NOTES.

THE CONTRACTOR SHALL COORDINATE ALL WORK WITH THE FOLLOWING INDIVIDUALS AND/OR ENTITIES:

**GENERAL CONTACTS:**

**COORDINATION:**

ENGINEER OF RECORD OSCAR J. CRUZ, P.E. 16650 N. KENDALL, SUITE 205 MIAMI, FL. 33196 305-432-6826 OCRUZ@CHROMEENG.COM	MIAMI-DADE COUNTY BRIDGE ENGINEER MANAGER GABRIEL DELGADO, P.E. MIAMI-DADE COUNTY DEPARTMENT OF TRANSPORTATION AND PUBLIC WORKS 701 NW 1ST COURT, MIAMI, FL. 33136 786-469-5371 GABRIEL.DELGADO@MIAMIDADE.GOV	UNITED STATES COAST GUARD OMAR BECEIRO WATERWAY MANAGEMENT SPECIALIST 100 MACARTHUR CAUSEWAY MIAMI BEACH, FL. 33139 305-535-4317	CITY OF MIAMI PUBLIC WORKS DEPARTMENT 444 SW 2ND AVENUE MIAMI, FL. 33130 305-416-1200
---	---	---	---

**PERMIT AGENCIES:**

RER LISA SPOTALINO 701 NW 1ST CT AVENUE FLOOR, #209 MIAMI, FL. 33136 305-372-6841	FLORIDA DEPARTMENT OF ENVIRONMENTAL PROTECTION JENNIFER SMITH 400 N. CONGRESS AVENUE SUITE 200 WEST PALM BEACH, FL. 33404 561-681-6642	USACE AUDREY SIU MIAMI REGULATIONS FIELD OFFICE 6TH 9900 SOUTHWEST 107TH AVENUE SUITE 203 MIAMI, FL 33176 305-779-6051
--	---	--

**UTILITIES OWNERS:**

COMPANIES	CONTACT	PHONE NUMBERS
COMCAST CABLE	LEONARD MAXWELL-NEWBOLD	954-447-8405
FPL FIBERNET LLC	DANNY HASKETT	305-552-2931
FLORIDA POWER & LIGHT-SUBAQUEOUS	TRACY STERN	800-868-9554
FLORIDA POWER & LIGHT TRANSMISSION	SEYED HAJASSADOLLAH	305-228-5290
MIAMI-DADE WATER & SEWER	SERGIO GARCIA	786-268-5320
AT&T DISTRIBUTION	STEVE LOW	305-222-8745

**RER - NATURAL RESOURCES DIVISION  
 PRELIMINARY APPROVAL**

**NAME** Micaela Soldi  
**DATE** 04/12/2021

**RER - NATURAL RESOURCES DIVISION  
 FINAL APPROVAL**

**NAME** Ashley Dominguez  
**DATE** 12/22/2022

**PAY ITEM NOTES:**  
 PAYMENT FOR INCIDENTAL ITEMS NOT SPECIFICALLY COVERED IN THE INDIVIDUAL BID ITEMS SHALL BE INCLUDED IN THE CONTRACT UNIT PRICE FOR THE BID ITEMS.

CONTRACTOR SHALL FURNISH ALL LABOR, MATERIALS, EQUIPMENT AND SUCH MISCELLANEOUS ITEMS AS NECESSARY TO COMPLETE THE REPAIRS AS INDICATED ON THE DRAWINGS OR AS DIRECTED BY THE ENGINEER.

CONTRACT UNIT PRICES FOR PAY ITEMS SHALL INCLUDE ADDITIONAL COSTS DUE TO ADVERSE WORK SITE CONDITIONS AND ENVIRONMENTAL COMPLIANCE COSTS.

**PAY ITEM NO. 101-1-A MOBILIZATION (L.S.):**  
 SHALL INCLUDE, BUT NOT LIMITED TO THE COST OF INSPECTION SCAFFOLDING, MOTORIZED INSPECTION VEHICLES, INSPECTION BOAT AND OPERATORS AND OTHER EQUIPMENT REQUIRED TO PROVIDE SAFE ACCESS FOR INSPECTION OR TESTING. A MANNED SAFETY BOAT SHALL BE PROVIDED AT THE BRIDGE SITE ANY TIME EMPLOYEES ARE WORKING OUTSIDE THE PROTECTION OF PERMANENT HANDRAILS OR BARRIERS.

**PAY ITEM NO. 104-11A FLOATING TURBIDITY BARRIER (L.F.):**  
 INCLUDES THE COST OF ALL CURTAINS NECESSARY TO REACH THE CHANNEL BOTTOM AND THE TEMPORARY CHANNEL MARKERS W/ LIGHTS.

**PAY ITEM NO. 110-82 STRUCTURAL TIMBER REMOVAL AND DISPOSAL (MB):**  
 ITEM INCLUDES THE COST OF THE REMOVAL AND DISPOSAL OF THE EXISTING TIMBER, WALES, SPACER BLOCKS, CATWALK PLANKS, DECK SUPPORTS AND CLEARANCE SIGN POST SUPPORTS WHICH HAS BEEN TREATED IN THE PAST WITH PRESERVATIVES AND SHALL BE CONSIDERED SPECIAL WASTE FOR DISPOSAL PURPOSES.

**PAY ITEM NO. 401-70-2 RESTORE SPALLED AREAS, LATEX MODIFIED MORTAR STYRENE-BUTADINE (C.F.):**  
 THIS PAY ITEM INCLUDES THE COST TO REPAIR SPALLED AREAS ON THE TOP OF THE CONCRETE PILES AND THE GENERATOR BUILDING ROOF DECK. REFER TO "PROJECT TECHNICAL SPECIAL PROVISIONS FOR CONCRETE SPALL REPAIRS" FOR ADDITIONAL INFORMATION. THIS PAY ITEM ALSO INCLUDES THE COST OF ADDITIONAL SPLICED REINFORCEMENT AND/OR GALVANIZED WIRE FABRIC REQUIRED FOR THE SPALL REPAIRS.

**PAY ITEM 460-6-1 LADDER AND PLATFORM (L.S.):**  
 THIS PAY ITEM INCLUDES A NEW ALUMINUM CAGE LADDER CONNECTING TO THE NEW CATWALK ON THE SE SIDE OF FENDER SYSTEM. CONTRACTOR SHALL SUBMIT SHOP DRAWINGS FOR THE ALUMINUM CAGE LADDER SIGNED AND SEALED BY A FLORIDA LICENSED ENGINEER FOR REVIEW AND APPROVAL PRIOR TO FABRICATION.

**PAY ITEM 470-1 TREATED STRUCTURAL TIMBER (MB):**  
 THIS PAY ITEM INCLUDES FULL COMPENSATION FOR THE INSTALLATION OF NEW TREATED STRUCTURAL TIMBER AS SPECIFIED IN THE PLANS, INCLUDING LABOR, EQUIPMENT AND MATERIALS REQUIRED TO INSTALL ALL TREATED STRUCTURAL TIMBER, FASTENERS, AND INCIDENTALS NECESSARY TO COMPLETE THE WORK. THIS PAY ITEM ALSO INCLUDES THE COST OF ALL HARDWARE, CABLES AND ERECTING CLEARANCE GAGE SIGNS.

**PAY ITEM 510-1-2 ELECTRICAL SYSTEM (REMOVAL)(EXISTING FIXED BRIDGE NAVIGATIONAL LIGHTS) (LS):**  
 THIS PAY ITEM INCLUDES THE REMOVAL OF ALL THE EXISTING ELECTRICAL INSTALLATION TO BE REPLACED WITH NEW ONES AT EACH BRIDGE. CONTRACTOR SHALL RETURN TO MIAMI DADE COUNTY DEPARTMENT OF TRANSPORTATION PUBLIC WORKS ALL THE REMOVED EXISTING FENDER NAVIGATIONAL LIGHTS.

**PAY ITEM 750-1-59 ARCHITECTURAL, BUILDING, REHAB (SF):**  
 TENDER HOUSE: THIS ITEM INCLUDES FULL COMPENSATION FOR THE REMOVAL AND INSTALLATION OF NEW ROOF TILES, INCLUDING LABOR, EQUIPMENT AND MATERIAL REQUIRED FOR THE IN-KIND INSTALLATION OF NEW ROOF TILE. PAY ITEM ALSO INCLUDES THE REMOVAL AND DISPOSAL OF THE DAMAGED EXISTING ROOF TILES.  
 EAST GENERATOR BUILDING: PAY ITEM INCLUDES STUCCO REPAIRS, PRESSURE CLEANING, PAINTING OF EXTERIOR WALLS AND SOFFIT, AS WELL AS THE CLEANING AND COATING OF THE STEEL DOOR GATE. COLOR TO BE COORDINATED WITH OWNER.

**PAY ITEM 751-7 ARCHITECTURAL ROOF REPAIRS (LS):**  
 EAST GENERATOR BUILDING: THIS ITEM INCLUDES FULL COMPENSATION FOR THE REMOVAL AND INSTALLATION OF 348 SF OF NEW MODIFIED BITUMEN ROOF SYSTEM INCLUDING LABOR, EQUIPMENT AND MATERIALS REQUIRED. PAY ITEM ALSO INCLUDES THE REMOVAL AND DISPOSAL OF THE EXISTING DAMAGED ROOF DECK.

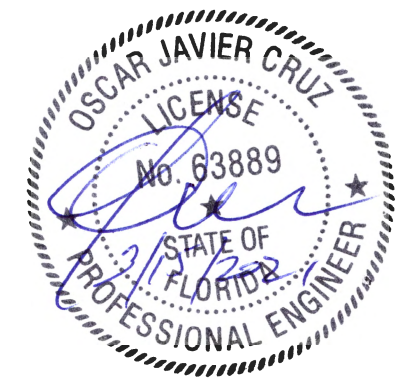

BRIDGE NO. 874459, 874474

REVISIONS							
DATE	BY	DESCRIPTION	DATE	BY	DESCRIPTION	DATE	BY



CHROME ENGINEERING, INC.  
 16650 N. KENDALL DR., SUITE 205  
 MIAMI FL, 33196  
 (305) 432-6826  
 OSCAR J. CRUZ, P.E. LICENSE # 63889

NAME	DATE	NAME	DATE
DESIGNED BY: JAC	06/22/2020	DRAWN BY: ML	08/25/2020
CHECKED BY: OC	11/05/2020	CHECKED BY: OC	11/05/2020

MIAMI-DADE COUNTY  
 TRANSPORTATION & PUBLIC WORKS DTPW  
 701 NW 1ST COURT  
 MIAMI, FLORIDA 33136

B-03

GENERAL NOTES  
 2 OF 3

STANDARD MANATEE CONDITIONS FOR IN - WATER WORK

- WEST INDIAN MANATEE (TRICHECHUS MANATUS LATIROSTRIS), A FEDERAL AND STATE LISTED ENDANGERED SPECIES, MAY MIGRATE THROUGH THE PROJECT AREA. THE PERMITTEE SHALL ADVISE ALL CONSTRUCTION PERSONNEL THAT THERE ARE CIVIL AND CRIMINAL PENALTIES FOR HARMING, HARASSING, OR KILLING MANATEES WHICH ARE PROTECTED UNDER THE MARINE MAMMAL PROTECTION ACT, THE ENDANGERED SPECIES ACT, AND THE FLORIDA MANATEE SANCTUARY ACT.
- THE CONTRACTOR SHALL POST TEMPORARY SIGN(S) IN A LOCATION PROMINENTLY VISIBLE TO WATER - RELATED CONSTRUCTION CREWS, MEASURING AT LEAST 3 BY 4 FEET THAT READS "CAUTION: MANATEE AREA", FOR A DURATION OF THE PROJECT. TEMPORARY SIGNS THAT HAVE BEEN APPROVED FOR THIS USE BY THE FLORIDA FISH AND WILDLIFE CONSERVATION COMMISSION (FWC) MUST BE USED (SEE MYFWC.COM/MANATEE). QUESTIONS CONCERNING THESE SIGNS CAN BE SENT TO THE E-MAIL ADDRESS LISTED ABOVE.
- ALL VESSELS ASSOCIATED WITH THE CONSTRUCTION SHALL OPERATE AT "IDLE SPEED/NO WAKE" AT ALL, SIGNAGE WILL BE DISPLAYED NEXT TO THE CONTROLS ON ALL CONSTRUCTION RELATED VESSELS, MEASURE AT LEAST 8.5 BY 11 INCHES, AND READ "CAUTION: MANATEE HABITAT" AND AT ALL TIMES WHILE IN THE IMMEDIATE AREA AND WHILE IN WATER WHERE THE DRAFT OF THE VESSEL PROVIDES LESS THAN A FOUR - FT CLEARANCE FROM THE BOTTOM. ALL VESSELS WILL FOLLOW ROUTES OF DEEP WATER WHENEVER POSSIBLE.
- THE CONTRACTOR IS RESPONSIBLE FOR PROVIDING A DESIGNATED, TRAINED MANATEE OBSERVER DURING ALL WATER RELATED ACTIVITIES. THAT PERSON IS TO BE EQUIPPED WITH POLARIZED SUNGLASSES TO AID IN OBSERVATION. THAT MANATEE OBSERVER SHALL BE ON SITE DURING ALL IN - WATER CONSTRUCTION ACTIVITIES AND ADVISED PERSONNEL TO CEASE OPERATION UPON SIGHTING A MANATEE WITH 50 FEET OF ANY IN - WATER CONSTRUCTION ACTIVITY. ACTIVITIES WILL NOT RESUME UNTIL THE MANATEE(S) HAS MOVED BEYOND THE 50 - FOOT RADIUS OF THE PROJECT OPERATION, OR UNTIL 30 MINUTES ELAPSES IF THE MANATEE(S) HAS NOT REAPPEARED WITHIN 50 FEET OF OPERATION. ANIMALS MUST NOT BE HERDED AWAY OR HARASSED INTO LEAVING.
- ANY COLLISION WITH OR INJURY TO A MANATEE SHALL BE REPORTED IMMEDIATELY TO THE FISH AND WILDLIFE CONSERVATION HOTLINE AT 1-888-404-3922. COLLISION AND/OR INJURY SHOULD ALSO BE REPORTED TO THE U.S. FISH AND WILDLIFE SERVICE IN JACKSONVILLE (1-904-731-3336) FOR NORTH FLORIDA OR VERO BEACH (1-772-562-3909) FOR SOUTH FLORIDA, AND TO FWC AT IMPERILEDSPESIES@MYFWC.COM
- SITUATION OR TURBIDITY BARRIERS SHALL BE MADE OF MATERIAL IN WHICH MANATEES CANNOT BECOME ENTANGLED, SHALL BE PROPERLY SECURED, AND SHALL BE REGULARLY MONITORED TO AVOID MANATEE ENTANGLEMENT OR ENTRAPMENT. BARRIERS MUST NOT IMPEDE MANATEE MOVEMENT.
- MANATEES CAN GET ENTANGLED AND GET PAST TURBIDITY BARRIERS. THEREFORE, TURBIDITY BARRIERS SHALL BE MONITORED EACH MORNING AND EACH EVENING AT THE END OF THE WORK SHIFT TO CHECK FOR ENTANGLEMENT IN THE BARRIERS, AND ENTRAPMENT IN THE CONSTRUCTION AREA IF A MANATEE CROSSES A BARRIER. IF A MANATEE BECOMES ENTANGLED IN A BARRIER THE FWC MUST BE NOTIFIED IMMEDIATELY AT 1-888-404-FWCC. IF A MANATEE BECOMES ENTRAPPED WITHIN THE CONSTRUCTION AREA, THE BARRIER NEEDS TO BE REMOVED AND ONLY BE REPLACED ONCE THE ANIMAL LEAVES THE AREA UPON ITS OWN VOLITION.

THE COST OF ALL ITEMS REQUIRED FOR THE MONITORING AND PROTECTION OF MANATEE SUCH AS, BUT NOT LIMITED TO MANATEE SIGNS, OBSERVERS, POLARIZED GLASSES, AND BINOCULARS, SHALL BE INCLUDED IN THE COST UNIT PRICE OF MOBILIZATION PAY ITEM NO. 101-1-A.

GENERAL NOTES:

- U.S. COAST GUARD NOTIFICATION: NOTIFY THE LOCAL OFFICE OF THE U.S. COAST GUARD AT LEAST 60 DAYS PRIOR TO BEGINNING CONSTRUCTION OF THE FENDER SYSTEM.
- CLEARANCE GAUGE AND LIGHT: CLEARANCE GAUGE TO BE FURNISHED AND INSTALLED BY THE CONTRACTOR. CLEARANCE GAUGE WIDTH AND NUMERAL HEIGHT IS DEPENDANT ON VISIBILITY DISTANCE. THE REQUIRED VISIBILITY DISTANCE SHALL BE DETERMINED BY THE UNITED STATES COAST GUARD DISTRICT COMMANDER. PROVIDE AND INSTALL CLEARANCE GAUGE LIGHT IN ACCORDANCE WITH FDOT SPECIFICATION SECTION 510 AND FDOT STANDARD PLANS 471-030.
- NAVIGATION LIGHTS: PROVIDE AND INSTALL NAVIGATION LIGHTS IN ACCORDANCE WITH PROJECT SPECIFIC DETAILS AND NOTES IN SHEETS BE-01 THROUGH BE-06. PROVIDE AND MAINTAIN TEMPORARY NAVIGATION LIGHTS DURING CONSTRUCTION UNTIL PERMANENT NAVIGATION LIGHTS ARE OPERATIONAL.
- BOLTS, THREADED BARS, NUTS, SCREWS AND WASHERS: FURNISH STAINLESS STEEL BOLTS IN ACCORDANCE WITH ASTM F593 TYPE 316. FURNISH STAINLESS STEEL THREADED BARS IN ACCORDANCE WITH ASTM A193 GRADE BB/VI. FURNISH STAINLESS STEEL NUTS IN ACCORDANCE WITH ASTM /VI F594 TYPE 316. FURNISH STAINLESS STEEL SCREWS IN ACCORDANCE WITH ASTM F593 TYPE 305. FURNISH STAINLESS STEEL WASHERS COMPATIBLE WITH BOLTS, THREADED RODS AND NUTS UNDER HEADS AND NUTS. TORQUE NUTS ON J" DIAMETER BOLTS AND THREADED BARS TO 150 LB-FT. KEEP THREADS ON BOLTS, THREADED BARS AND NUTS FREE FROM DIRT, COARSE GRIME AND SAND TO PREVENT GALLING AND SEIZING DURING TIGHTENING.
- WIRE ROPE: PROVIDE WIRE ROPE MEETING ONE OF THE FOLLOWING REQUIREMENTS:
  - 1/2" DIAMETER 6X19, 6X25 OR 6X37 CLASS IWRC TYPE 316 STAINLESS STEEL WIRE ROPE WITH A MINIMUM BREAKING STRENGTH OF 18,000 LBS.
  - 1/2" DIAMETER 6X 19 GALVANIZED WIRE ROPE WITH ULTRAVIOLET RAY RESISTANT POLYPROPYLENE IMPREGNATION HAVING AN OUTSIDE DIAMETER OF 5/8" WITH A MINIMUM BREAKING STRENGTH OF 22,000 LBS. PROTECT ALL ENDS WITH HEAT SHRINKABLE END CAPS COMPATIBLE WITH THE ROPE'S POLYPROPYLENE THAT PROVIDE AN EFFECTIVE WATER-TIGHT SEAL.

GENERAL NOTES (CONTD.):

- DURING ALL CONSTRUCTION OPERATIONS, THE CONTRACTOR SHALL NOT BE ALLOWED TO DROP WASTE CONCRETE, DEBRIS, OR OTHER MATERIAL INTO THE CHANNEL BELOW THE BRIDGE. PLATFORMS, NETS, SCREENS, OR OTHER PROTECTIVE DEVICES SHALL BE USED TO CATCH THE MATERIAL. IF THE ENGINEER DETERMINES THAT ADEQUATE PROTECTIVE DEVICES ARE NOT BEING EMPLOYED, THE WORK SHALL BE SUSPENDED UNTIL ADEQUATE PROTECTION IS PROVIDED. THE COST OF PROVIDING SUCH PROTECTIVE DEVICES SHALL BE INCIDENTAL TO THE APPLICABLE ITEMS OF WORK HAVING AWARDED CONTRACT PRICES.
- NO SPOIL AREA IS AVAILABLE FOR THIS CONTRACT WITHIN THE MIAMI-DADE COUNTY RIGHT-OF-WAY. ALL SPOIL MATERIAL (STRUCTURAL, CONCRETE, REINFORCING STEEL, ETC.) REMOVED FROM THE JOB SITE SHALL BE DISPOSED BY THE CONTRACTOR OFF OF THE MIAMI-DADE COUNTY PROPERTY. THE CONTRACTOR SHALL COMPLY WITH THE LOCAL AND STATE REGULATIONS THAT APPLY TO THE AREA CHOSEN FOR DISPOSAL OF THIS SPOIL MATERIAL. THE COST OF THIS WORK SHALL BE INCLUDED IN OTHER RELATED ITEMS. NO SEPARATE PAYMENT WILL BE ALLOWED.
- ALL EXCESS MATERIAL AS DESIGNATED BY THE ENGINEER IS TO BE DISPOSED BY THE CONTRACTOR IN AREAS PROVIDED BY HIM WITHIN 72 HOURS OF BEING DEPOSITED IN THE CONSTRUCTION AREA AND AT THE CONTRACTOR'S EXPENSE.
- CHAMFER: ALL EXPOSED EDGES AND CORNERS OF CONCRETE SHALL BE CHAMFERED IN ACCORDANCE WITH THE STANDARD SPECIFICATIONS.
- ALL TIMBER TO BE ROUGH-CUT AND SHALL RECEIVE "SALT WATER" TREATMENT IN ACCORDANCE WITH SECTION 955 OF THE SPECIFICATIONS, UNLESS OTHERWISE SPECIFIED.
- ALL TIMBER SHALL BE CUT TO DIMENSIONS SHOWN PRIOR TO TREATMENT.
- PAYMENT FOR INCIDENTAL ITEMS NOT SPECIFICALLY COVERED IN INDIVIDUAL BID ITEMS SHALL BE INCLUDED IN THE CONTRACT PRICES FOR BID ITEMS.
- DOMEHAD BOLTS SHALL HAVE SLOTS OR HOLES ON HEADS FOR 60D NAILS.
- QUANTITIES: DUE TO THE NATURE OF THE DETERIORATION PRESENT ON THESE FENDERS, MIAMI-DADE COUNTY HAS THE AUTHORITY TO INCREASE, DECREASE, OR DELETE THE QUANTITIES OF WORK TO BE PERFORMED IN EXCESS OR BELOW THE PERCENTAGES ALLOWED BY FDOT SECTION 4-3.1 OF THE STANDARD SPECIFICATIONS AND REVISIONS THERETO WITH NO ADJUSTMENT TO THE CONTRACT UNIT PRICES AS STATED UNDER DTPW, GENERAL REQUIREMENTS, ARTICLE 1.02.B. THE WORK WILL BE ASSIGNED BY THE ENGINEER FOR A SPECIFIC GROUP OF LOCATIONS AT A TIME. IN ADDITION TO THE LOCATIONS OF CONCRETE/SPALL REPAIRS SHOWN IN THE PLANS, THE CONTRACTOR WILL PERFORM A SURVEY OF THE BRIDGE FENDER PILES AND GENERATOR BUILDING CONCRETE SLAB IN THE PRESENCE OF THE ENGINEER PRIOR TO COMMENCING ANY WORK IN ORDER TO IDENTIFY ALL LOCATIONS IN NEED OF REPAIR. NO CONCRETE REMOVAL WILL BE PERFORMED WITHOUT THE ENGINEER'S APPROVAL. THE MIAMI-DADE COUNTY WILL BE ALLOWED TO STOP WORK DUE TO POOR WORKMANSHIP, UNAPPROVED MATERIALS OR UNAPPROVED WORK PROCEDURE AT ANY TIME WITHOUT CONSEQUENCE TO MIAMI-DADE COUNTY.
- THE CONTRACTOR WILL ADHERE TO THE REQUIREMENTS OF THE TECHNICAL SPECIAL PROVISIONS FOR CONCRETE SPALL REPAIRS WITH POLYMER MODIFIED PORT/AND CEMENT MORTAR. PLACE THE POLYMER MODIFIED PORT/AND CEMENT MORTAR WITH CORROSION INHIBITORS IN ACCORDANCE WITH MANUFACTURER'S RECOMMENDATIONS.
- IN THE EVENT THAT MORE THAN 20% OF THE CROSS SECTIONAL AREA OF ANY STRUCTURAL MEMBER NEEDS TO BE REMOVED, PRIOR TO THE REMOVAL OF MORE THAN 20% OF THE MEMBER CROSS SECTIONAL AREA, THE CONTRACTOR WILL STOP WORK AND NOTIFY THE ENGINEER FOR FURTHER INSTRUCTIONS.
- STAGING AREA: CONTRACTOR SHALL COORDINATE THE LOCATION OF ANY REQUIRED STAGING AREA WITH MIAMI-DADE PARKS, RECREATION AND OPEN SPACES DEPARTMENT LOCATED AT 275 NW 2ND STREET, 4TH FLOOR, MIAMI, FLORIDA, 33128. CONTACT NUMBER: 305-755-5464
- MAINTENANCE OF TRAFFIC: VEHICULAR, BICYCLE AND PEDESTRIAN ACCESS SHALL NOT BE CLOSED AT ANY TIME DURING CONSTRUCTION OPERATIONS. CONTRACTOR SHALL PROVIDE SIGNED AND SEALED TRAFFIC CONTROL PLANS FOR REVIEW AND APPROVAL BY MIAMI-DADE COUNTY PUBLIC WORKS DEPARTMENT FOR ANY VEHICULAR LANE, BICYCLE LANE AND/OR SIDEWALK CLOSURE REQUESTS.
- UTILITIES: FOR PLAN LOCATION OF EXISTING UTILITIES, SEE THE PLAN AND ELEVATION SHEETS. CONTACT SUNSHINE ONE OF FLORIDA BEFORE BEGINNING WORK FOR LOCATIONS OF EXISTING FACILITIES AT 1-800-432-4770. THE CONTRACTOR SHALL NOTIFY ALL POTENTIALLY AFFECTED UTILITY OWNERS TWO (2) FULL WORKING DAYS IN ADVANCE PRIOR TO BEGINNING ANY CONSTRUCTION ACTIVITIES.

**RER - NATURAL RESOURCES DIVISION  
 FINAL APPROVAL**  
 NAME Ashley Dominguez  
 DATE 12/22/2022

**RER - NATURAL RESOURCES DIVISION  
 PRELIMINARY APPROVAL**  
 NAME Micaela Soldi  
 DATE 04/12/2021

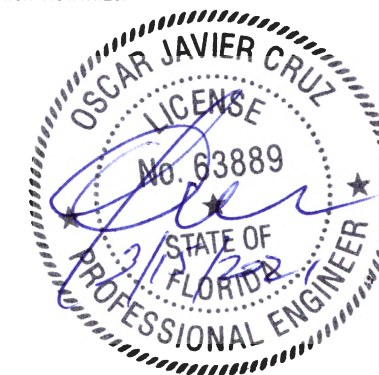

BRIDGE NO. 874459, 874474

C:\Users\mlemus\chrome\chrome\Projects\20-1\3\700\_CADD\B2-B4-General Notes.dwg Mar 15, 2021 - 12:41pm MLEMUS

REVISIONS								 CHROME ENGINEERING, INC. 16650 N. KENDALL DR., SUITE 205 MIAMI FL, 33196 (305) 432-6826 OSCAR J. CRUZ, P.E. LICENSE # 63889	MIAMI-DADE COUNTY TRANSPORTATION & PUBLIC WORKS DTPW 701 NW 1ST COURT MIAMI, FLORIDA 33136			
DATE	BY	DESCRIPTION	DATE	BY	DESCRIPTION	DATE	BY		DESCRIPTION	DATE	BY	DESCRIPTION

B-04

GENERAL NOTES  
 3 OF 3

**RER - NATURAL RESOURCES DIVISION  
 PRELIMINARY APPROVAL**  
 NAME Micaela Soldi  
 DATE 04/12/2021

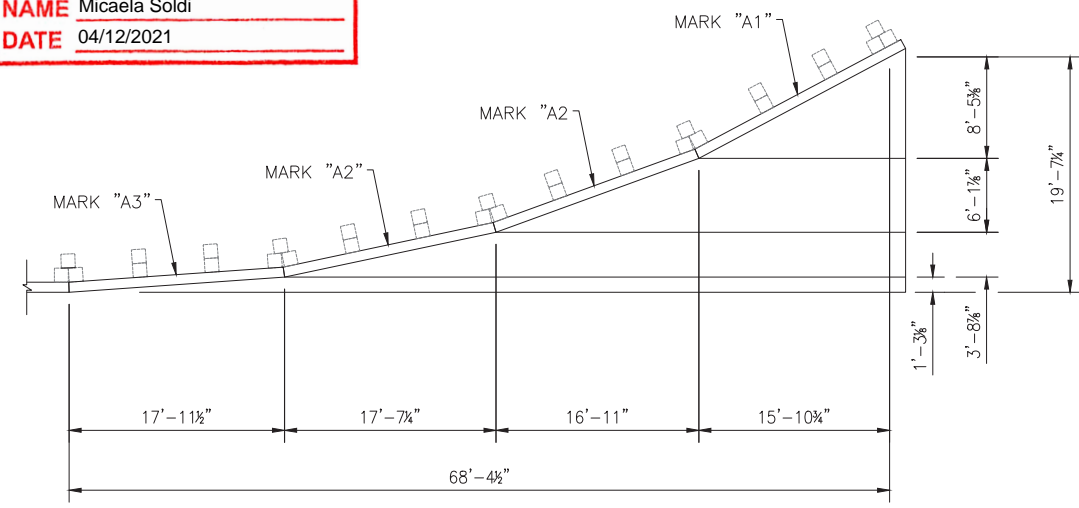
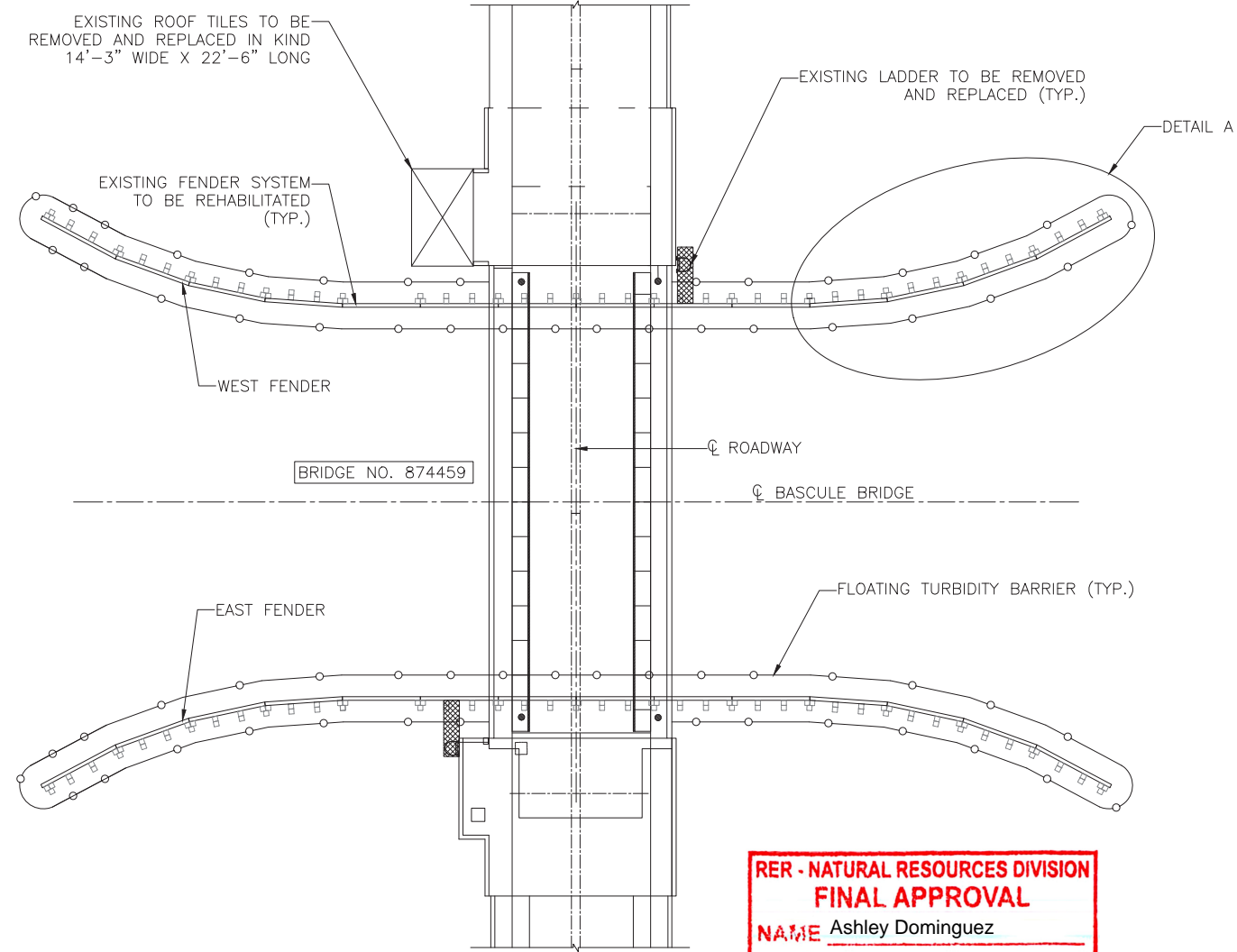

DETAIL A

- NOTES:
1. FOR FENDER CROSS SECTION SEE SHEET B-09.
  2. FOR LOCATIONS OF DAMAGED/MISSING WALES, SPACER BLOCKS, CAT WALK PLANKS, DECK SUPPORTS AND WIRE CABLES SEE SHEET B-06.
  3. FOR DETAILS OF WALES, SPACER BLOCKS, CATWALK PLANKS, DECK SUPPORTS, WIRE CABLE AND ASSOCIATED CONNECTIONS, SEE SHEET B-10.
  4. FOR NEW NAVIGATIONAL LIGHTS SEE BE-06.
  5. ALL ELEMENTS SHOWN ON THIS SHEET ARE EXISTING UNLESS OTHERWISE NOTED, AND ARE BASED ON INFORMATION OBTAINED FROM EXISTING DRAWINGS AND WITH LIMITED FIELD INVESTIGATION.
  6. OVERALL LENGTH OF EXISTING WEST FENDER = 252 LINEAR FEET
  7. OVERALL LENGTH OF EXISTING EAST FENDER = 252 LINEAR FEET

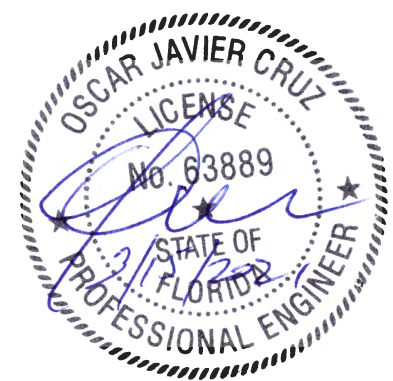

**RER - NATURAL RESOURCES DIVISION  
 FINAL APPROVAL**  
 NAME Ashley Dominguez  
 DATE 12/22/2022

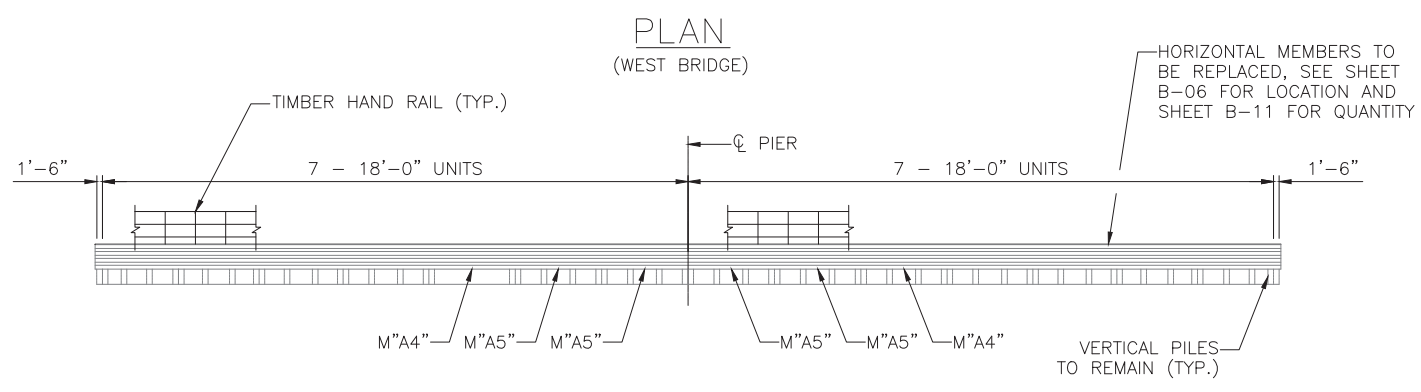

WEST AND EAST FENDER

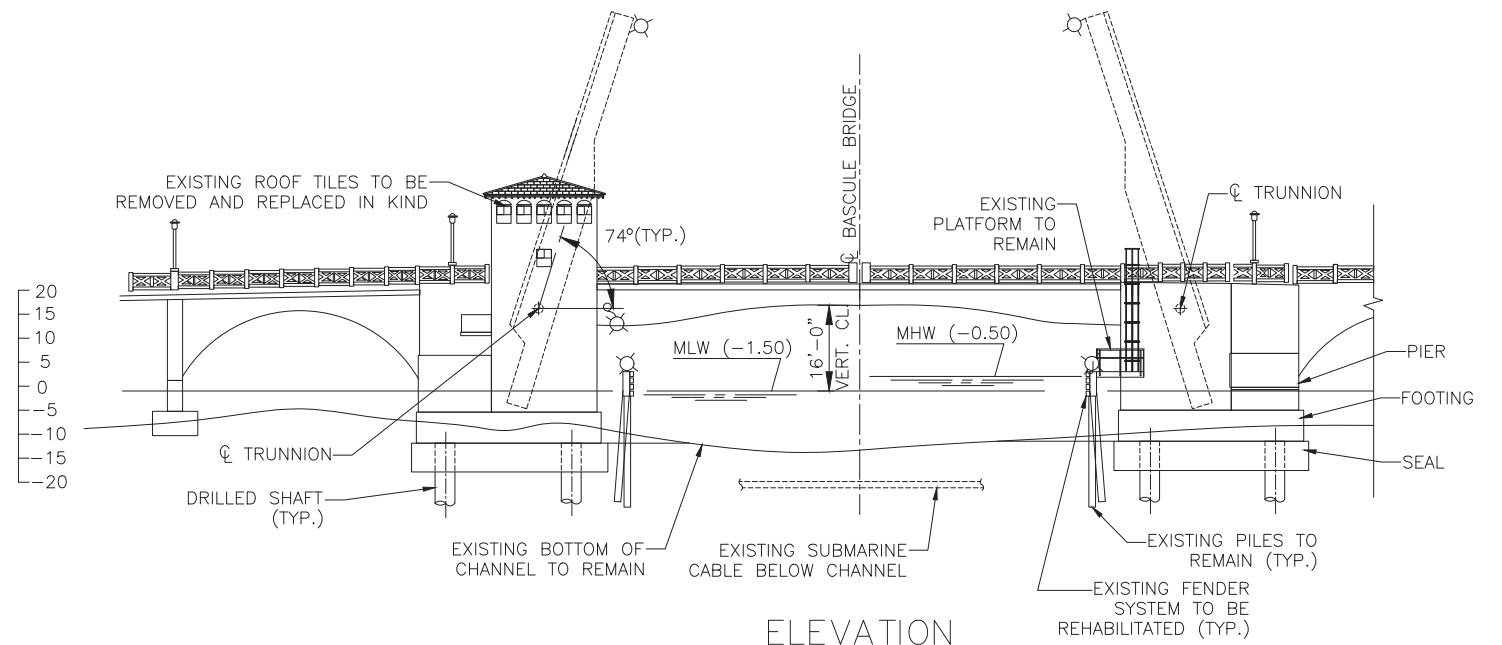

ELEVATION

BRIDGE NO. 874459

REVISIONS					
DATE	BY	DESCRIPTION	DATE	BY	DESCRIPTION



CHROME ENGINEERING, INC.  
 16650 N. KENDALL DR., SUITE 205  
 MIAMI FL, 33196  
 (305) 432-6826  
 OSCAR J. CRUZ, P.E. LICENSE # 63889

NAME	DATE	NAME	DATE
DESIGNED BY: JAC	06/22/2020	DRAWN BY: ML	08/25/2020
CHECKED BY: OC	11/05/2020	CHECKED BY: OC	11/05/2020

MIAMI-DADE COUNTY  
 TRANSPORTATION & PUBLIC WORKS DTPW  
 701 NW 1ST COURT  
 MIAMI, FLORIDA 33136

B-05

PLAN AND ELEVATION  
 BRIDGE 874459

C:\Users\mlemus\chromeeng.com\Chrome Engineering - Projects\20-13\700\_CADD\B5-B6\_Plan and Elevation West.dwg Mar 15, 2021 12:41pm MLEMUS

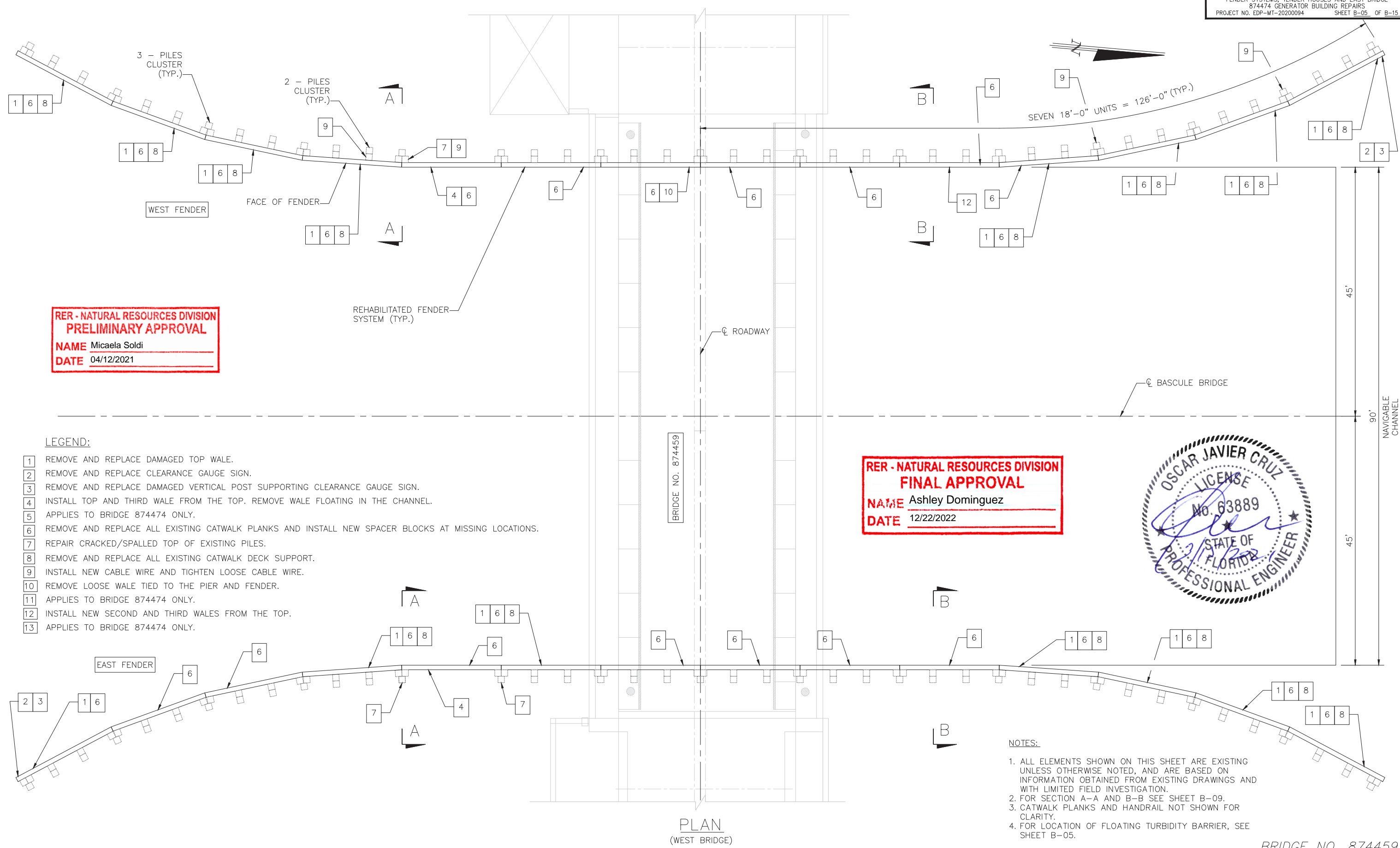

**RER - NATURAL RESOURCES DIVISION  
 PRELIMINARY APPROVAL**  
 NAME Micaela Soldi  
 DATE 04/12/2021

**RER - NATURAL RESOURCES DIVISION  
 FINAL APPROVAL**  
 NAME Ashley Dominguez  
 DATE 12/22/2022



**LEGEND:**

- 1 REMOVE AND REPLACE DAMAGED TOP WALE.
- 2 REMOVE AND REPLACE CLEARANCE GAUGE SIGN.
- 3 REMOVE AND REPLACE DAMAGED VERTICAL POST SUPPORTING CLEARANCE GAUGE SIGN.
- 4 INSTALL TOP AND THIRD WALE FROM THE TOP. REMOVE WALE FLOATING IN THE CHANNEL.
- 5 APPLIES TO BRIDGE 874474 ONLY.
- 6 REMOVE AND REPLACE ALL EXISTING CATWALK PLANKS AND INSTALL NEW SPACER BLOCKS AT MISSING LOCATIONS.
- 7 REPAIR CRACKED/SPALLED TOP OF EXISTING PILES.
- 8 REMOVE AND REPLACE ALL EXISTING CATWALK DECK SUPPORT.
- 9 INSTALL NEW CABLE WIRE AND TIGHTEN LOOSE CABLE WIRE.
- 10 REMOVE LOOSE WALE TIED TO THE PIER AND FENDER.
- 11 APPLIES TO BRIDGE 874474 ONLY.
- 12 INSTALL NEW SECOND AND THIRD WALES FROM THE TOP.
- 13 APPLIES TO BRIDGE 874474 ONLY.

**NOTES:**

1. ALL ELEMENTS SHOWN ON THIS SHEET ARE EXISTING UNLESS OTHERWISE NOTED, AND ARE BASED ON INFORMATION OBTAINED FROM EXISTING DRAWINGS AND WITH LIMITED FIELD INVESTIGATION.
2. FOR SECTION A-A AND B-B SEE SHEET B-09.
3. CATWALK PLANKS AND HANDRAIL NOT SHOWN FOR CLARITY.
4. FOR LOCATION OF FLOATING TURBIDITY BARRIER, SEE SHEET B-05.

**PLAN**  
(WEST BRIDGE)

BRIDGE NO. 874459

C:\Users\mlemus\chrome\chrome\Projects\20-13\700\_CADD\B5-B6\_Plan and Elevation West.dwg Mar 15, 2021 - 12:41pm MLEMUS

REVISIONS					
DATE	BY	DESCRIPTION	DATE	BY	DESCRIPTION



CHROME ENGINEERING, INC.  
 16650 N. KENDALL DR., SUITE 205  
 MIAMI FL, 33196  
 (305) 432-6826  
 OSCAR J. CRUZ, P.E. LICENSE # 63889

DESIGNED BY	NAME	DATE	DRAWN BY	NAME	DATE
JAC	JAC	06/22/2020	ML	ML	08/25/2020
CHECKED BY	OC	11/05/2020	CHECKED BY	OC	11/05/2020
SUPERVISED BY:					

MIAMI-DADE COUNTY  
 TRANSPORTATION & PUBLIC WORKS DTPW  
 701 NW 1ST COURT  
 MIAMI, FLORIDA 33136

B-06  
**FENDER SYSTEM PLAN**  
 VIEW BRIDGE 874459



**RER - NATURAL RESOURCES DIVISION  
 PRELIMINARY APPROVAL**  
 NAME Micaela Soldi  
 DATE 04/12/2021

**RER - NATURAL RESOURCES DIVISION  
 FINAL APPROVAL**  
 NAME Ashley Dominguez  
 DATE 12/22/2022

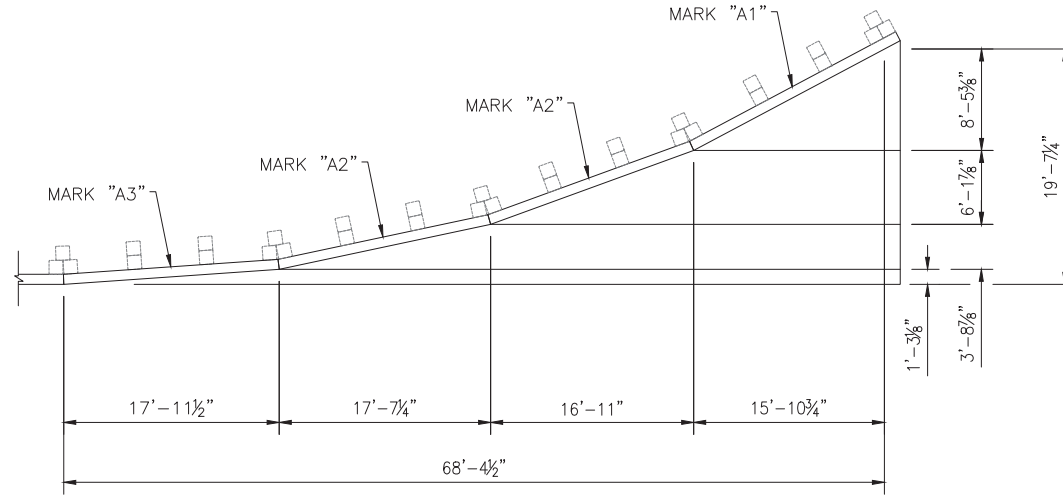
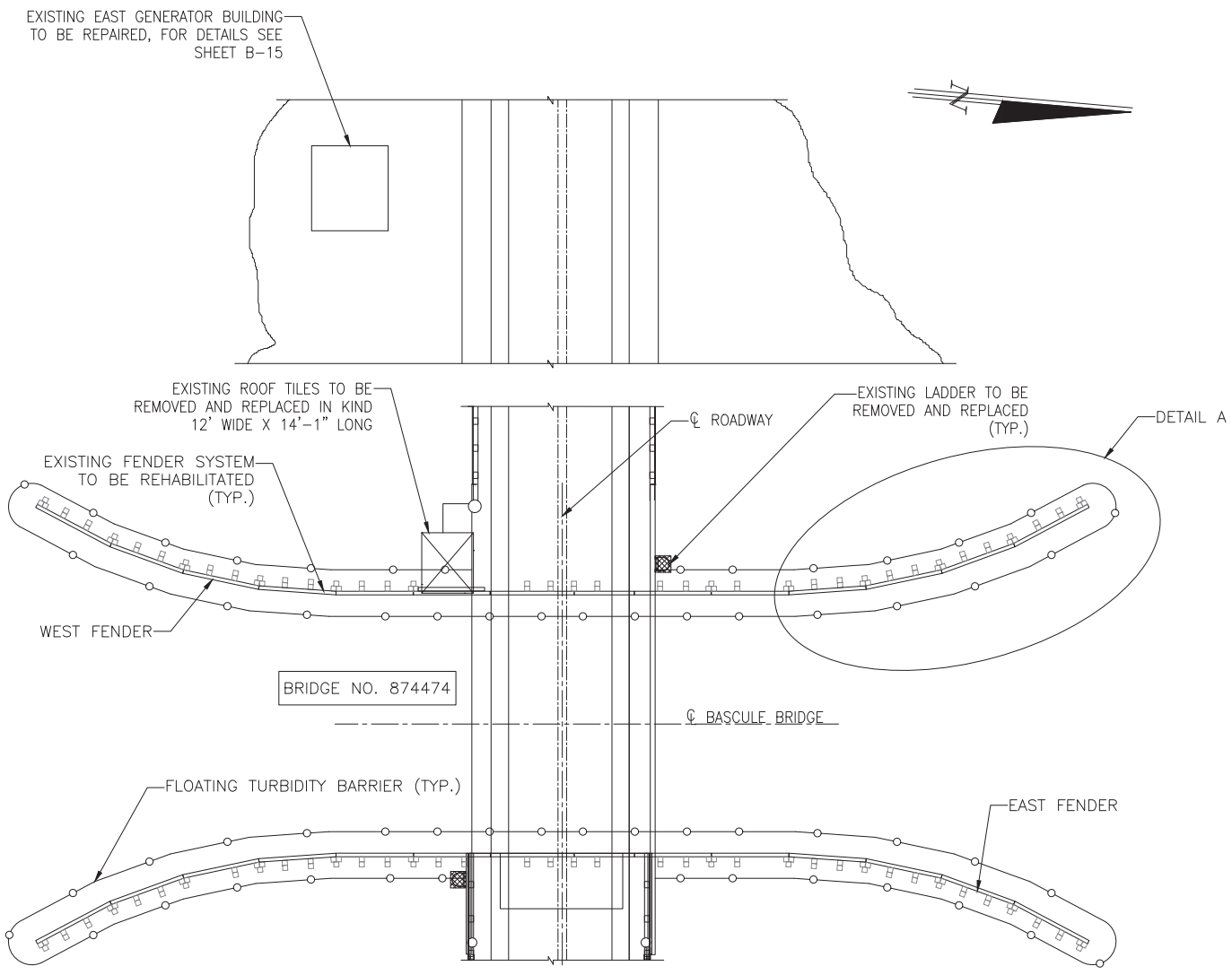

DETAIL A

NOTES:

1. FOR FENDER CROSS SECTION SEE SHEET B-10.
2. FOR LOCATIONS OF DAMAGED/MISSING WALES, SPACER BLOCKS, CATWALK PLANKS, DECK SUPPORTS AND WIRE CABLES SEE SHEET B-08.
3. FOR DETAILS OF WALES, SPACER BLOCKS, CATWALK PLANKS, DECK SUPPORTS, WIRE CABLE AND ASSOCIATED CONNECTIONS, SEE SHEET B-10.
4. FOR NEW NAVIGATIONAL LIGHTS SEE SHEET BE-06.
5. ALL ELEMENTS SHOWN ON THIS SHEET ARE EXISTING UNLESS OTHERWISE NOTED, AND ARE BASED ON INFORMATION OBTAINED FROM EXISTING DRAWINGS AND WITH LIMITED FIELD INVESTIGATION.
6. OVERALL LENGTH OF EXISTING WEST FENDER = 250 LINEAR FEET
7. OVERALL LENGTH OF EXISTING EAST FENDER = 250 LINEAR FEET
8. FOR EAST GENERATOR BUILDING REPAIRS SEE SHEET B-14.

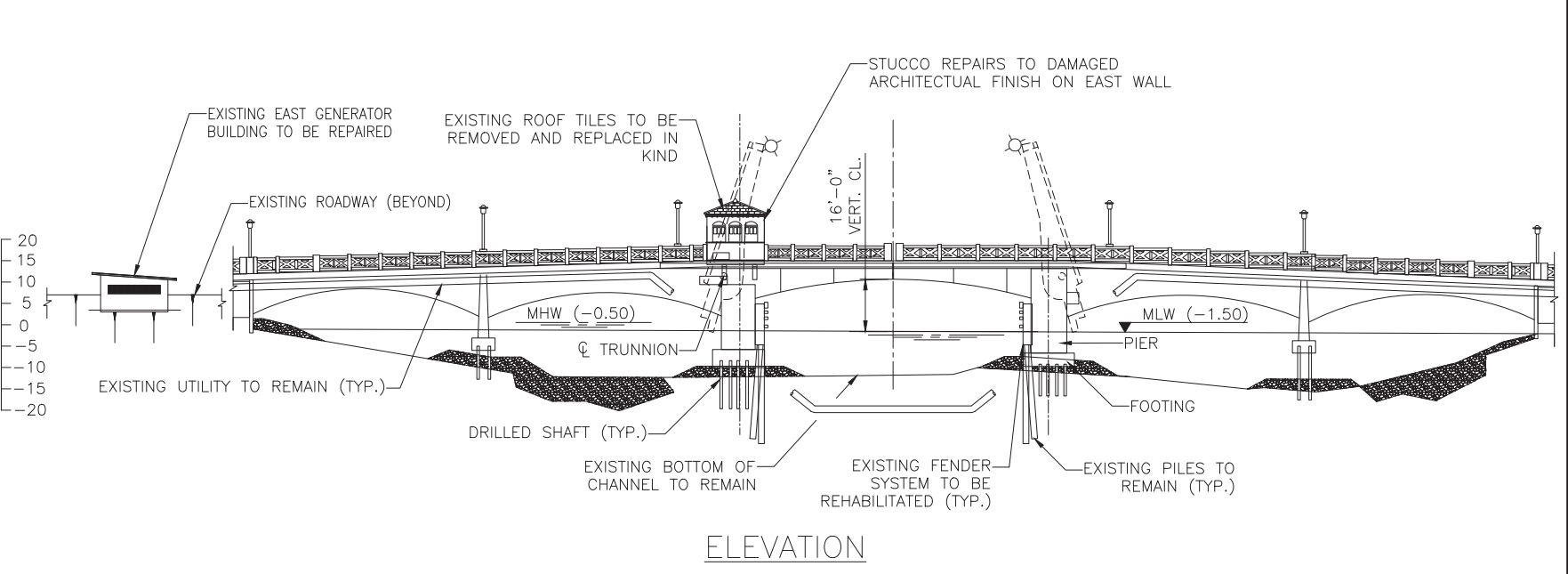
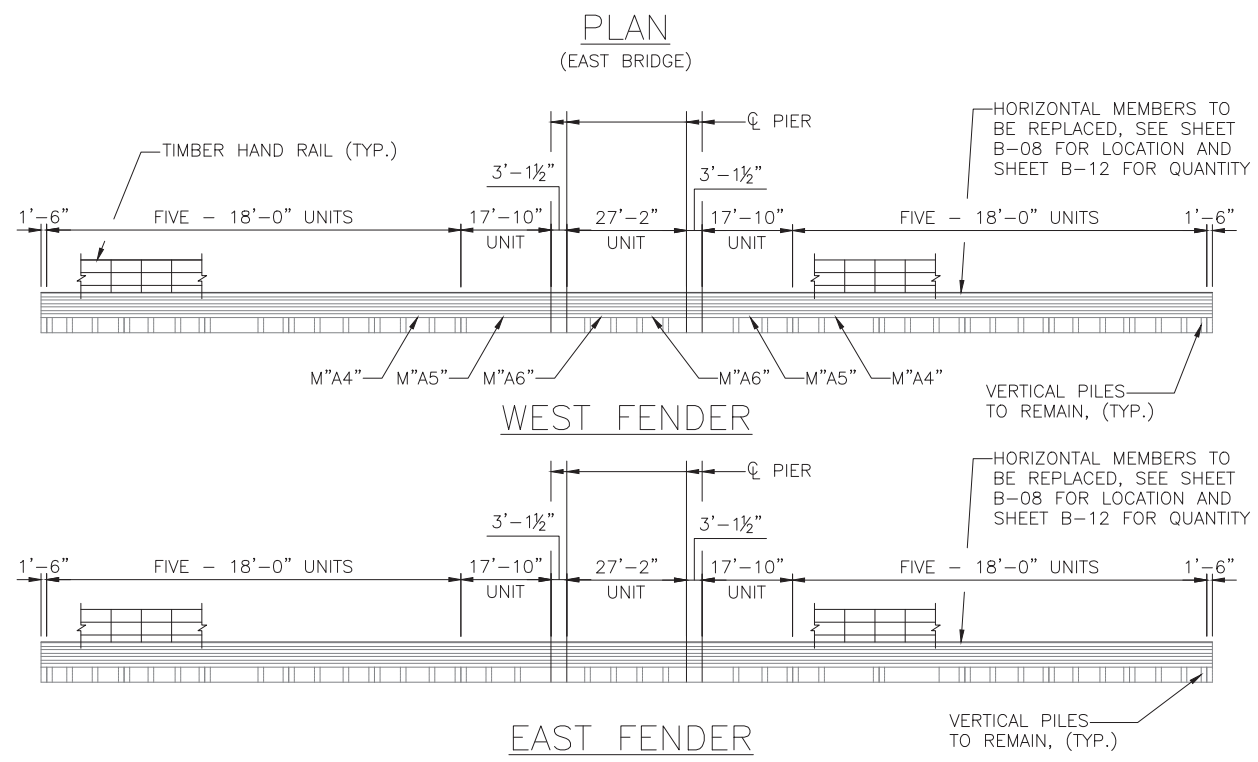
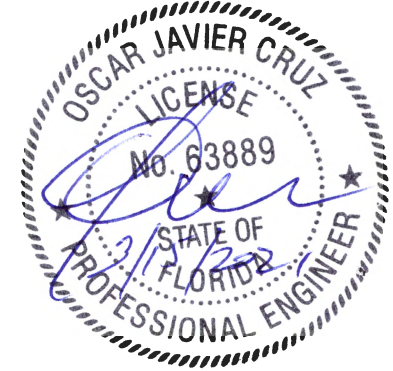

ELEVATION

BRIDGE NO. 874474

REVISIONS					
DATE	BY	DESCRIPTION	DATE	BY	DESCRIPTION



CHROME ENGINEERING, INC.  
 16650 N. KENDALL DR., SUITE 205  
 MIAMI FL, 33196  
 (305) 432-6826  
 OSCAR J. CRUZ, P.E. LICENSE # 63889

NAME	DATE	NAME	DATE
DESIGNED BY: JAC	06/22/2020	DRAWN BY: ML	08/25/2020
CHECKED BY: OC	11/05/2020	CHECKED BY: OC	11/05/2020

MIAMI-DADE COUNTY  
 TRANSPORTATION & PUBLIC WORKS DTPW  
 701 NW 1ST COURT  
 MIAMI, FLORIDA 33136

B-07

PLAN AND ELEVATION  
 BRIDGE 874474

C:\Users\mlemus\chromeeng.com\Chrome Engineering - Projects\20-13\700\_CADD\B7-B8\_Plan and Elevation East.dwg Mar 15, 2021 - 12:41pm MLEMUS

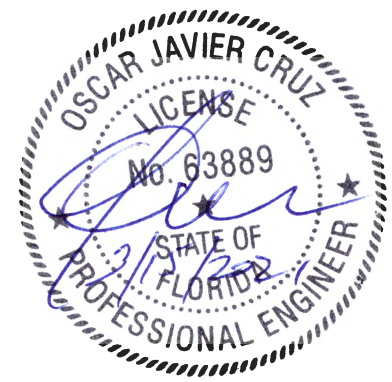
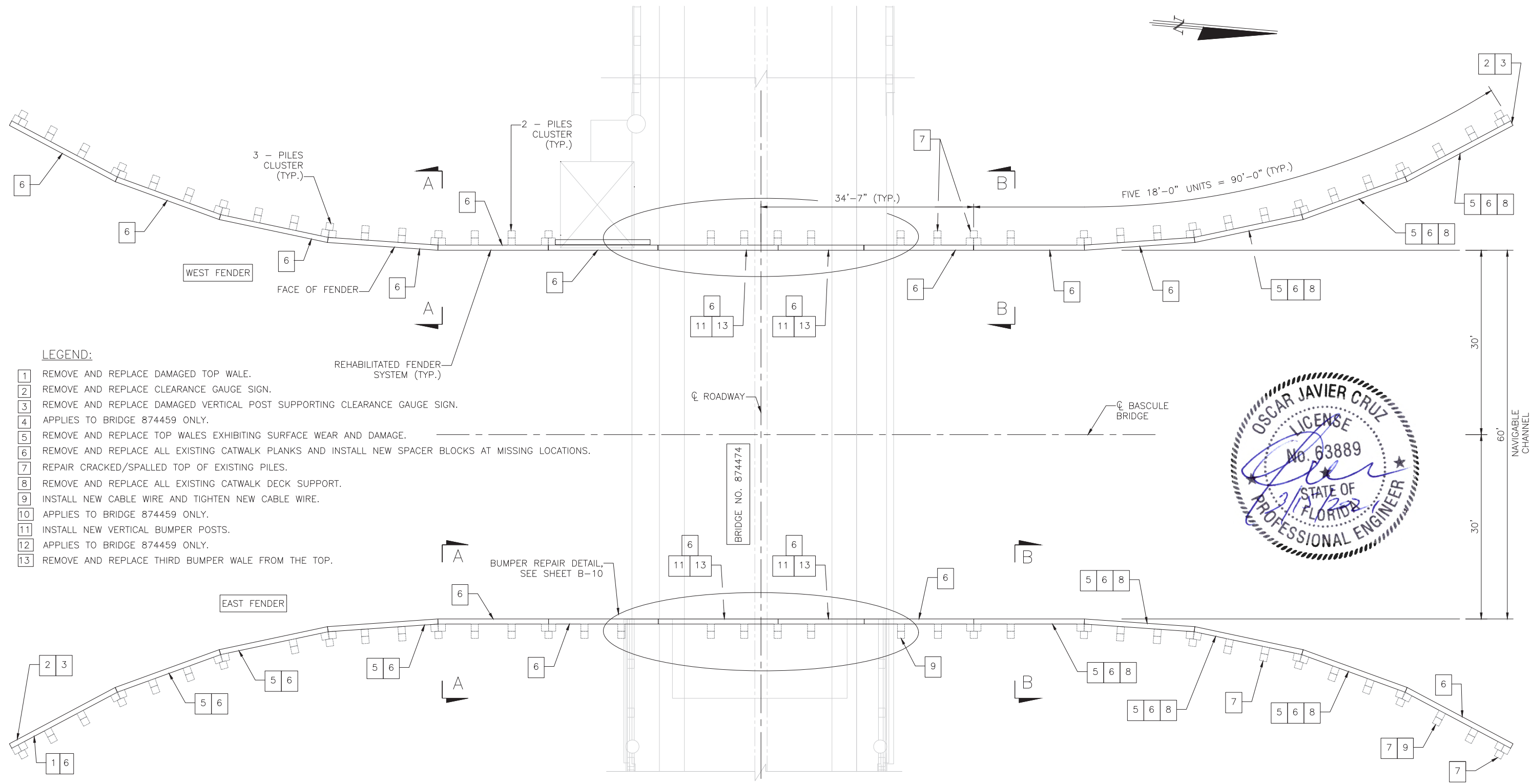

**LEGEND:**

- 1 REMOVE AND REPLACE DAMAGED TOP WALE.
- 2 REMOVE AND REPLACE CLEARANCE GAUGE SIGN.
- 3 REMOVE AND REPLACE DAMAGED VERTICAL POST SUPPORTING CLEARANCE GAUGE SIGN.
- 4 APPLIES TO BRIDGE 874459 ONLY.
- 5 REMOVE AND REPLACE TOP WALES EXHIBITING SURFACE WEAR AND DAMAGE.
- 6 REMOVE AND REPLACE ALL EXISTING CATWALK PLANKS AND INSTALL NEW SPACER BLOCKS AT MISSING LOCATIONS.
- 7 REPAIR CRACKED/SPALLED TOP OF EXISTING PILES.
- 8 REMOVE AND REPLACE ALL EXISTING CATWALK DECK SUPPORT.
- 9 INSTALL NEW CABLE WIRE AND TIGHTEN NEW CABLE WIRE.
- 10 APPLIES TO BRIDGE 874459 ONLY.
- 11 INSTALL NEW VERTICAL BUMPER POSTS.
- 12 APPLIES TO BRIDGE 874459 ONLY.
- 13 REMOVE AND REPLACE THIRD BUMPER WALE FROM THE TOP.

**NOTES:**

1. ALL ELEMENTS SHOWN ON THIS SHEET ARE EXISTING UNLESS OTHERWISE NOTED, AND ARE BASED ON INFORMATION OBTAINED FROM EXISTING DRAWINGS AND WITH LIMITED FIELD INVESTIGATION.
2. FOR SECTION A-A AND B-B SEE SHEET B-09.
3. CATWALK PLANKS AND HANDRAIL NOT SHOWN FOR CLARITY.
4. FOR LOCATION OF FLOATING TURBIDITY BARRIER, SEE SHEET B-07.

**RER - NATURAL RESOURCES DIVISION  
 PRELIMINARY APPROVAL**  
 NAME Micaela Soldi  
 DATE 04/12/2021

**RER - NATURAL RESOURCES DIVISION  
 FINAL APPROVAL**  
 NAME Ashley Dominguez  
 DATE 12/22/2022

**PLAN**  
 (EAST BRIDGE)

BRIDGE NO. 874474

C:\Users\mlemus\chromeeng.com\Projects\20-13\700\_CADD\B7-B8\_Plan and Elevation East.dwg Mar 15, 2021 - 12:41pm MLEMUS

REVISIONS					
DATE	BY	DESCRIPTION	DATE	BY	DESCRIPTION



CHROME ENGINEERING, INC.  
 16650 N. KENDALL DR., SUITE 205  
 MIAMI FL, 33196  
 (305) 432-6826  
 OSCAR J. CRUZ, P.E. LICENSE # 63889

NAME	DATE	NAME	DATE
DESIGNED BY: JAC	06/22/2020	DRAWN BY: ML	08/25/2020
CHECKED BY: OC	11/05/2020	CHECKED BY: OC	11/05/2020

MIAMI-DADE COUNTY  
 TRANSPORTATION & PUBLIC WORKS DTPW  
 701 NW 1ST COURT  
 MIAMI, FLORIDA 33136

B-08  
**FENDER SYSTEM PLAN  
 VIEW BRIDGE 874474**

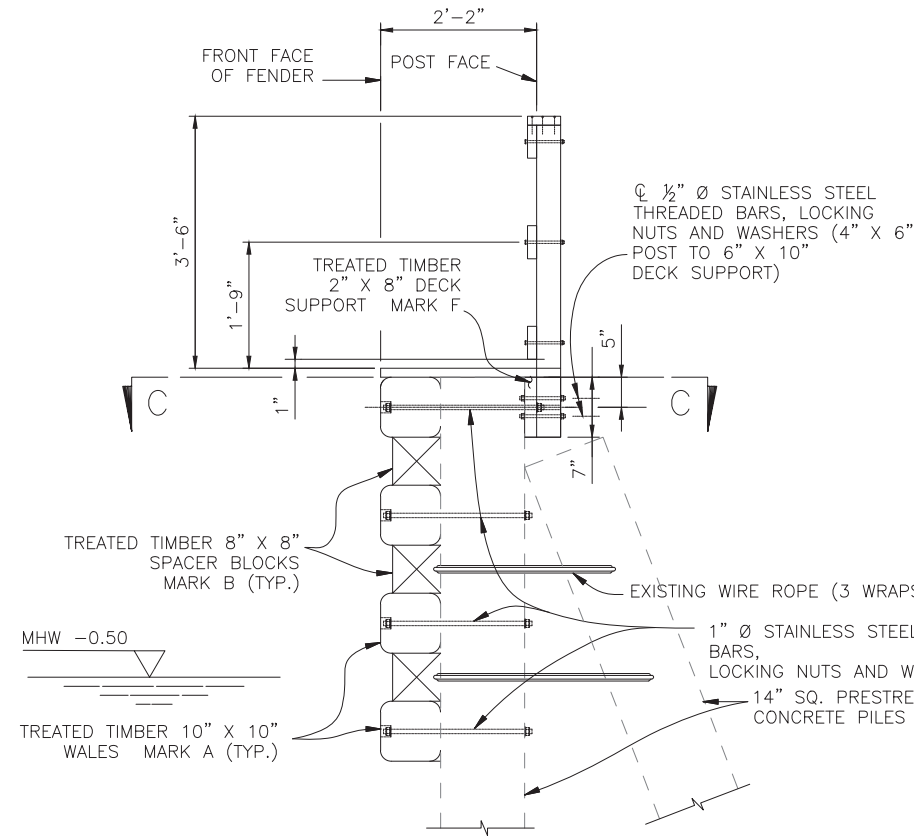

SECTION A-A

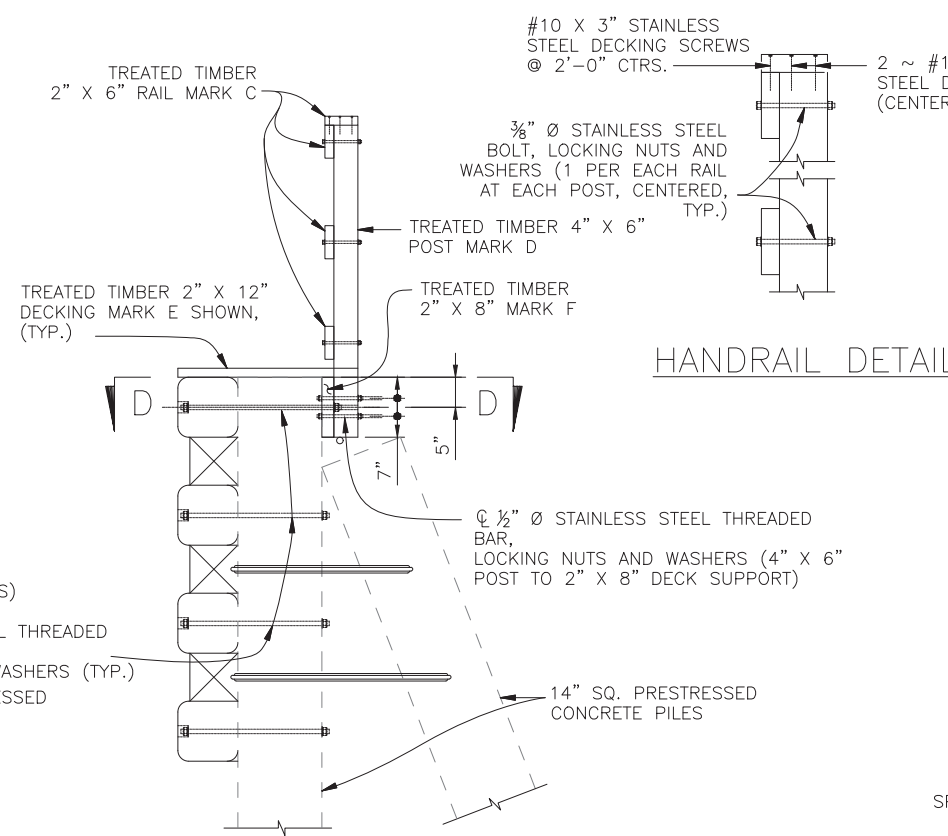

SECTION B-B

HANDRAIL DETAIL

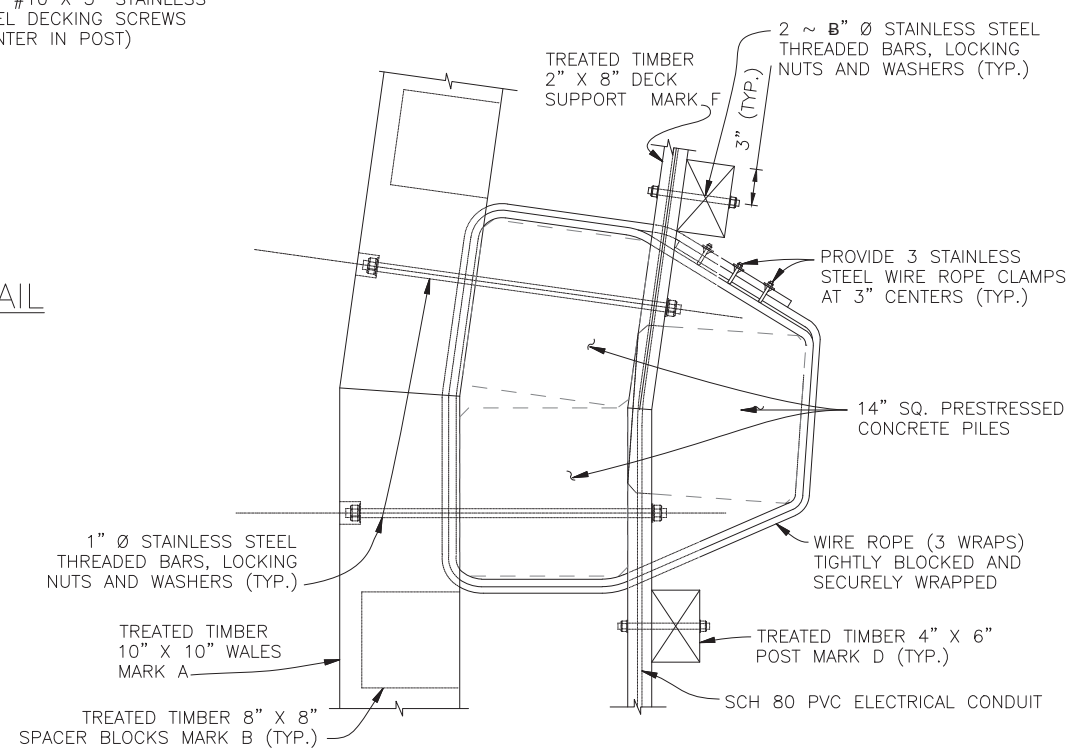

SECTION C-C  
 (3 PILES CLUSTER)  
 TYPICAL FLARED SECTION

**RER - NATURAL RESOURCES DIVISION  
 PRELIMINARY APPROVAL**  
 NAME Micaela Soldi  
 DATE 04/12/2021

**RER - NATURAL RESOURCES DIVISION  
 FINAL APPROVAL**  
 NAME Ashley Dominguez  
 DATE 12/22/2022

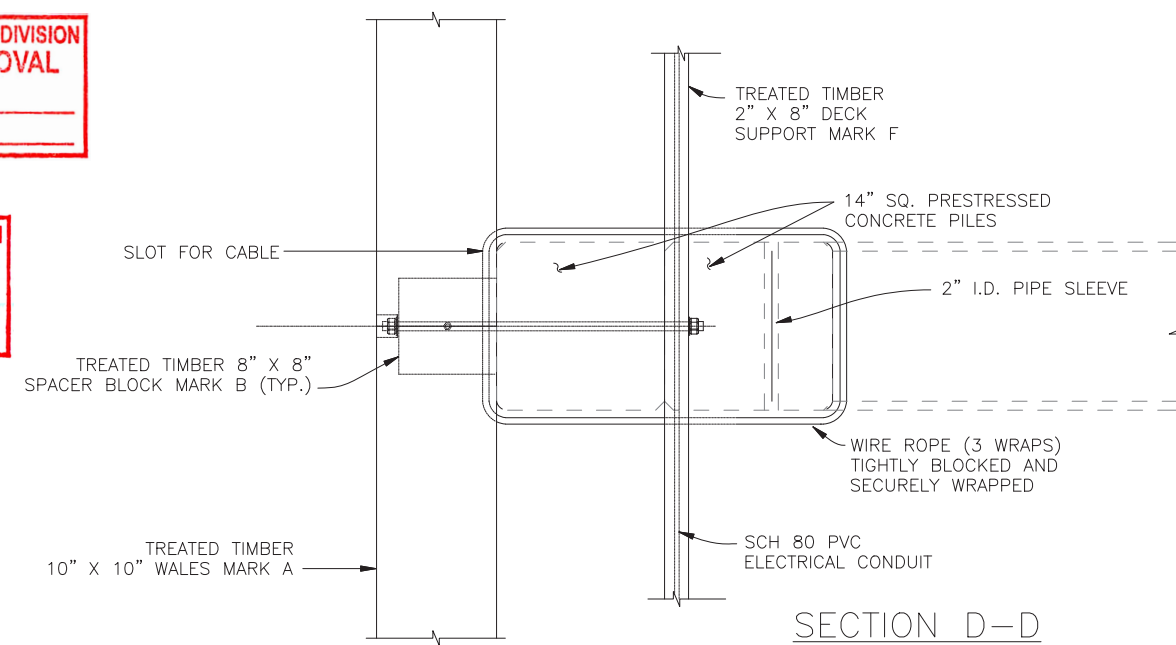

SECTION D-D  
 (2 PILES CLUSTER)  
 TYPICAL AT INTERMEDIATE PILES

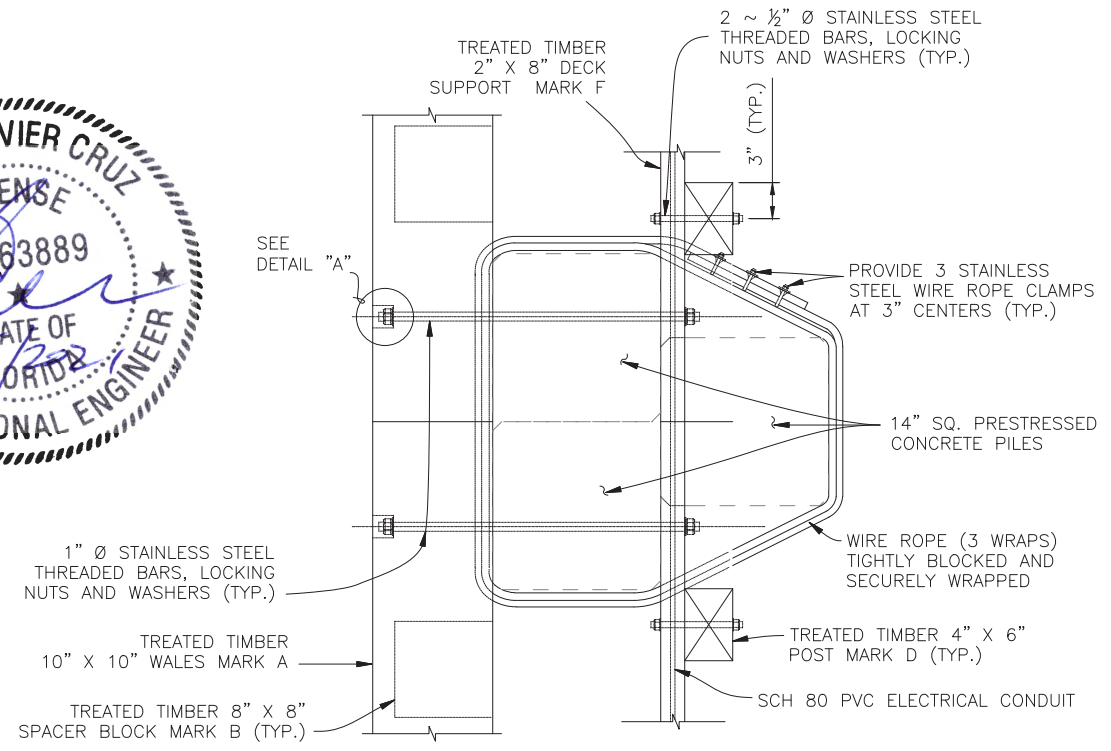

SECTION C-C  
 (3 PILES CLUSTER)  
 TYPICAL STRAIGHT SECTION

BRIDGE NO. 874459, 874474

C:\Users\mlemus\chromeeng.com\Chrome Engineering - Projects\20-13\700\_CADD\B9-B12\_Fender System Details.dwg Mar 15, 2021 - 12:41pm MLEMUS

REVISIONS					
DATE	BY	DESCRIPTION	DATE	BY	DESCRIPTION

**CHROME ENGINEERING, INC.**  
 16650 N. KENDALL DR., SUITE 205  
 MIAMI FL, 33196  
 (305) 432-6826  
 OSCAR J. CRUZ, P.E. LICENSE # 63889

NAME	DATE	NAME	DATE
DESIGNED BY: JAC	06/22/2020	DRAWN BY: ML	08/25/2020
CHECKED BY: OC	11/05/2020	CHECKED BY: OC	11/05/2020
SUPERVISED BY:			

**MIAMI-DADE COUNTY**  
 TRANSPORTATION & PUBLIC WORKS DTPW  
 701 NW 1ST COURT  
 MIAMI, FLORIDA 33136

**B-09**  
 FENDER SYSTEM  
 DETAILS 1 OF 2

**RER - NATURAL RESOURCES DIVISION  
PRELIMINARY APPROVAL**

NAME Micaela Soldi  
DATE 04/12/2021

**RER - NATURAL RESOURCES DIVISION  
FINAL APPROVAL**

NAME Ashley Dominguez  
DATE 12/22/2022

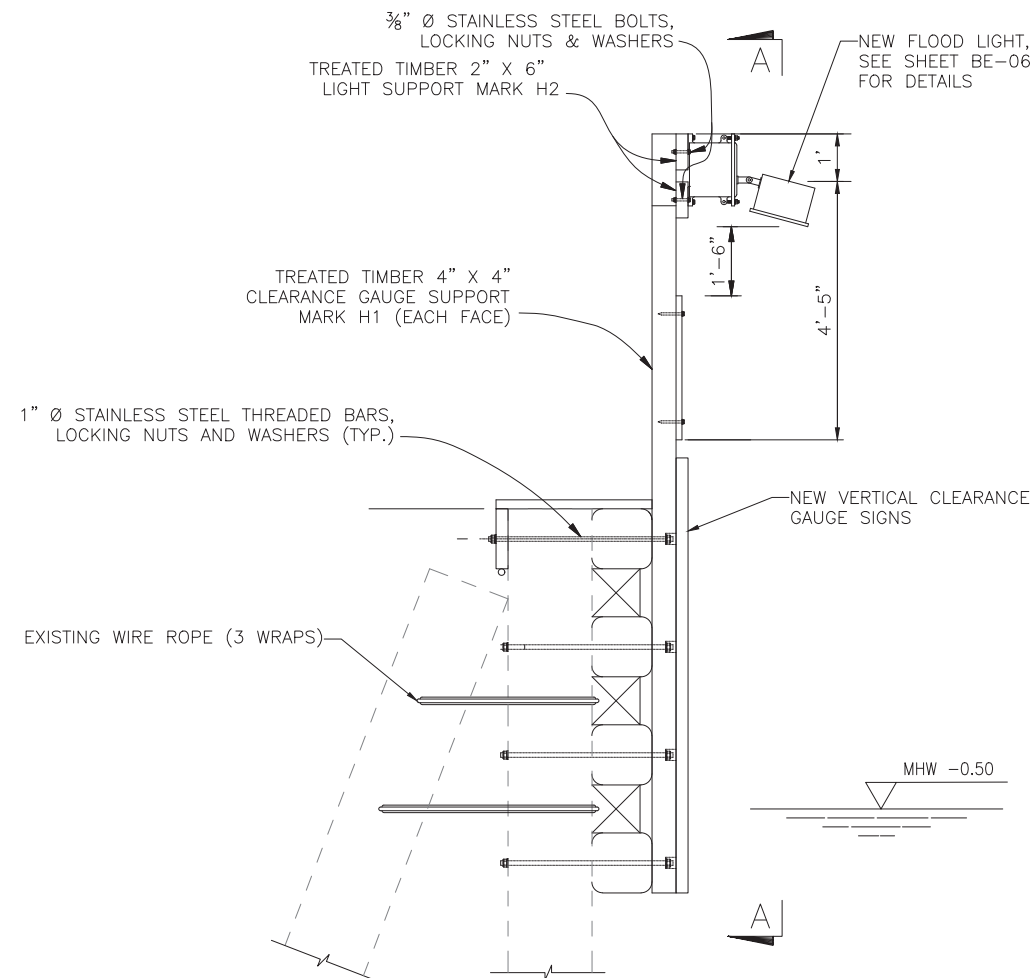
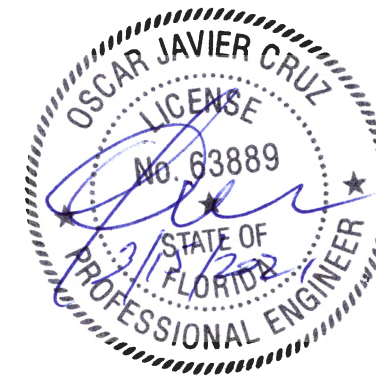

CLEARING GAUGE MOUNTING DETAIL

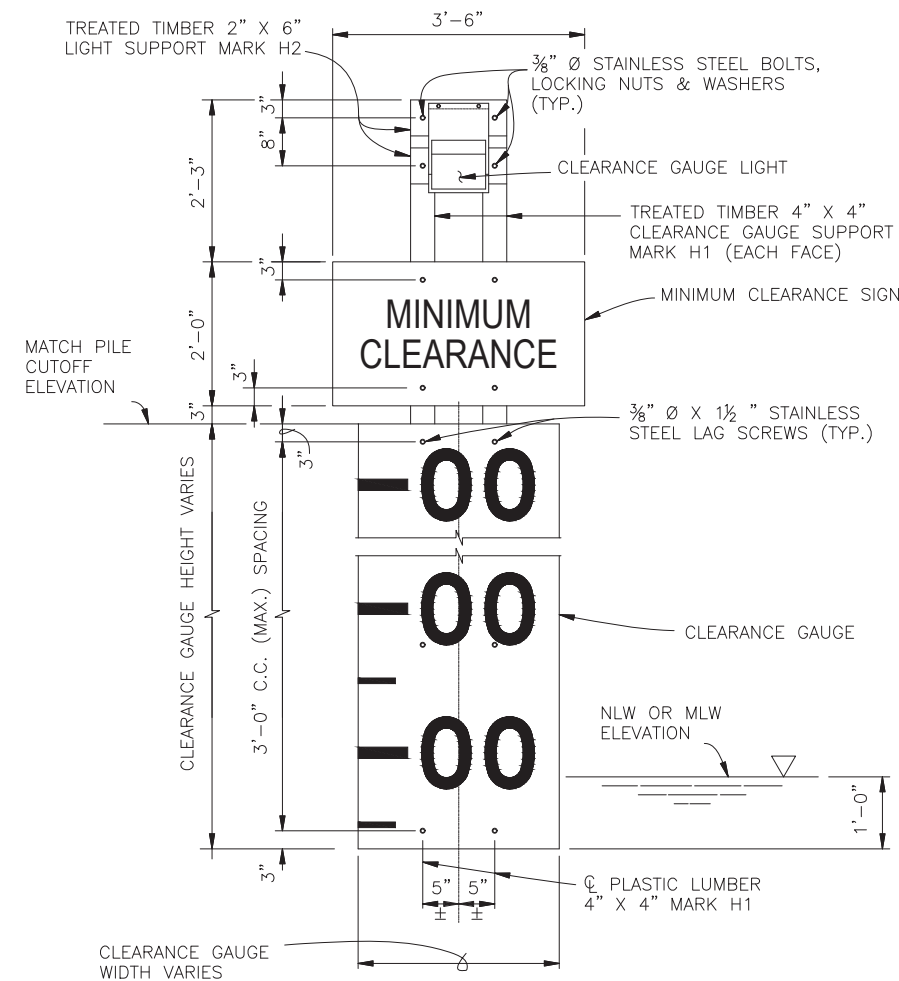

VIEW A-A  
(WALES, PILES AND BRACING NOT SHOWN FOR CLARITY)

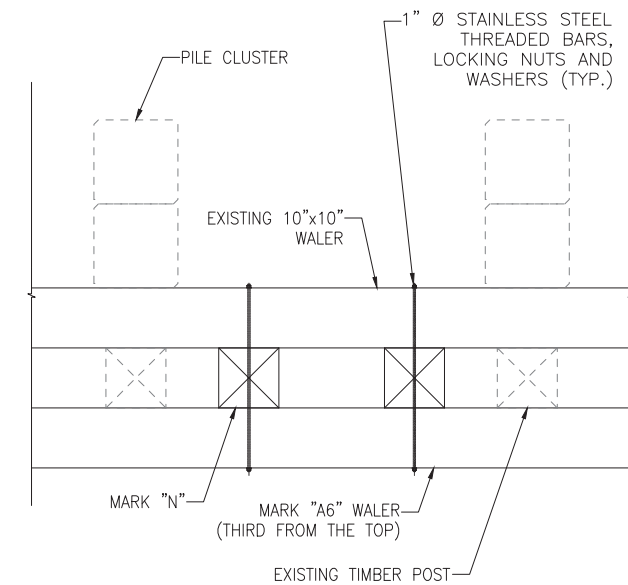

BUMPER REPAIR DETAIL  
(APPLICABLE TO FENDERS AT BRIDGE 874474 ONLY)

C:\Users\mlemus\chromeeng.com\Chrome Engineering - Projects\20-1\700\_CADD\B9-B12\_Fender System Details.dwg Mar 15, 2021 - 12:41pm MLEMUS

REVISIONS					
DATE	BY	DESCRIPTION	DATE	BY	DESCRIPTION



CHROME ENGINEERING, INC.  
16650 N. KENDALL DR., SUITE 205  
MIAMI FL, 33196  
(305) 432-6826  
OSCAR J. CRUZ, P.E. LICENSE # 63889

NAME	DATE	NAME	DATE
DESIGNED BY: JAC	06/22/2020	DRAWN BY: ML	08/25/2020
CHECKED BY: OC	11/05/2020	CHECKED BY: OC	11/05/2020
SUPERVISED BY:			



TRANSPORTATION & PUBLIC WORKS DTPW  
701 NW 1ST COURT  
MIAMI, FLORIDA 33136

B-10

FENDER SYSTEM  
DETAILS 2 OF 2

BRIDGE NO. 874459, 874474

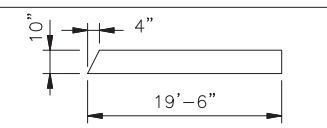
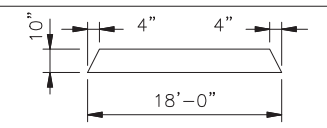
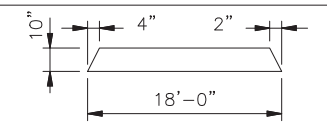
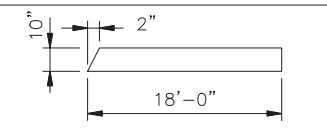
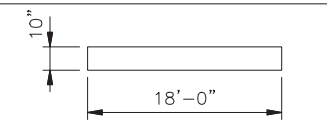
STRUCTURAL TREATED TIMBER BILL OF MATERIALS					
MARK	SIZE (NOMINAL)	DIMENSIONS	BOARD FT. PER EACH	NO. REQD.	QUANTITY (MB)
A1	10" X 10" TREATED TIMBER		162.5	4	0.650
A2	10" X 10" TREATED TIMBER		150.0	6	0.900
A3	10" X 10" TREATED TIMBER		150.0	4	0.600
A4	10" X 10" TREATED TIMBER		150.0	2	0.300
A5	10" X 10" TREATED TIMBER		150.0	1	0.150

\* ALL TREATED TIMBER DIMENSIONS AND QUANTITIES SHOWN ARE BASED ON THE NOMINAL LUMBER DIMENSIONS AND MAY VARY DEPENDING ON ACTUAL TIMBER DIMENSION.  
 \*\* QUANTITY SHOWN ASSUMES 10% REPLACEMENT OF ORIGINAL FENDER QUANTITY FOR BLOCK SPACERS MARK B1 AND B2.

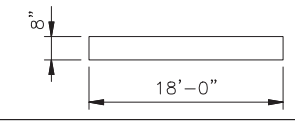
TREATED TIMBER BILL OF MATERIALS					
MARK	SIZE (NOMINAL)	DIMENSIONS	BOARD FT. PER EACH	NO. REQD.	QUANTITY (MB)
B1	8" X 8" TREATED TIMBER	1'-2" (STRAIGHT)	6.2	40	0.249
B2	8" X 8" TREATED TIMBER	1'-10" (STRAIGHT) (TRIM & MITER ENDS AS REQUIRED)	9.8	3	0.029
C	2" X 6" TREATED TIMBER	18'-0" (STRAIGHT)	18.0	112	2.016
D	4" X 6" TREATED TIMBER	4'-4" (STRAIGHT) (HANDRAIL POST)	9.0	84	0.756
E	2" X 12" TREATED TIMBER	2'-2" (STRAIGHT)	4.3	438	1.898
F	2" X 8" TREATED TIMBER		24.0	14	0.336
H1	4" X 4" TREATED TIMBER	14'-10" (STRAIGHT)	19.8	4	0.079
H2	2" X 6" TREATED TIMBER	1'-2" (STRAIGHT)	1.2	4	0.005

**RER - NATURAL RESOURCES DIVISION  
 PRELIMINARY APPROVAL**  
 NAME Micaela Soldi  
 DATE 04/12/2021

**RER - NATURAL RESOURCES DIVISION  
 FINAL APPROVAL**  
 NAME Ashley Dominguez  
 DATE 12/22/2022



BRIDGE NO. 874459

REVISIONS					
DATE	BY	DESCRIPTION	DATE	BY	DESCRIPTION



CHROME ENGINEERING, INC.  
 16650 N. KENDALL DR., SUITE 205  
 MIAMI FL, 33196  
 (305) 432-6826  
 OSCAR J. CRUZ, P.E. LICENSE # 63889

DESIGNED BY	NAME	DATE	DRAWN BY	NAME	DATE
JAC	JAC	06/22/2020	ML	ML	08/25/2020
CHECKED BY	NAME	DATE	CHECKED BY	NAME	DATE
OC	OC	11/05/2020	OC	OC	11/05/2020

MIAMI-DADE COUNTY  
 TRANSPORTATION & PUBLIC WORKS DTPW  
 701 NW 1ST COURT  
 MIAMI, FLORIDA 33136

B-11 STRUCTURAL TREATED TIMBER BILL OF MATERIALS  
 1 OF 2

STRUCTURAL TREATED TIMBER BILL OF MATERIALS					
MARK	SIZE (NOMINAL)	DIMENSIONS	BOARD FT. PER EACH	NO. REQD.	QUANTITY (MB)
A1	10" X 10" TREATED TIMBER		150.0	2	0.300
A2	10" X 10" TREATED TIMBER		150.0	6	0.900
A3	10" X 10" TREATED TIMBER		150.0	2	0.300
A4	10" X 10" TREATED TIMBER		150.0	1	0.150
A5	10" X 10" TREATED TIMBER		166.7	0	0.000
A6	10" X 10" TREATED TIMBER		131.3	4	0.525

TREATED TIMBER BILL OF MATERIALS					
MARK	SIZE (NOMINAL)	DIMENSIONS	BOARD FT. PER EACH	NO. REQD.	QUANTITY (MB)
B1	8" X 8" TREATED TIMBER	1'-2" (STRAIGHT)	6.2	37	0.230
B2	8" X 8" TREATED TIMBER	1'-10" (STRAIGHT) (TRIM & MITER ENDS AS REQUIRED)	9.8	3	0.029
C	2" X 6" TREATED TIMBER	18'-0" (STRAIGHT)	18.0	112	2.016
D	4" X 6" TREATED TIMBER	4'-4" (STRAIGHT) (HANDRAIL POST)	9.0	84	0.756
E	2" X 12" TREATED TIMBER	2'-2" (STRAIGHT)	4.3	496	2.149
F	2" X 8" TREATED TIMBER		24.0	7	0.168
H1	4" X 4" TREATED TIMBER	14'-10" (STRAIGHT)	19.8	4	0.079
H2	2" X 6" TREATED TIMBER	1'-2" (STRAIGHT)	1.2	4	0.005
N	10" X 10" TREATED TIMBER	4'-6" (STRAIGHT - VERTICAL) (BUMPER REPAIR DETAIL)	37.5	32	1.200

\* ALL TREATED TIMBER DIMENSIONS AND QUANTITIES SHOWN ARE BASED ON THE NOMINAL LUMBER DIMENSIONS AND MAY VARY DEPENDING ON ACTUAL TIMBER DIMENSION.  
 \*\* QUANTITY SHOWN ASSUMES 10% REPLACEMENT OF ORIGINAL FENDER QUANTITY FOR BLOCK SPACERS MARK B1 AND B2.

**RER - NATURAL RESOURCES DIVISION  
 PRELIMINARY APPROVAL**  
 NAME Micaela Soldi  
 DATE 04/12/2021

**RER - NATURAL RESOURCES DIVISION  
 FINAL APPROVAL**  
 NAME Ashley Dominguez  
 DATE 12/22/2022

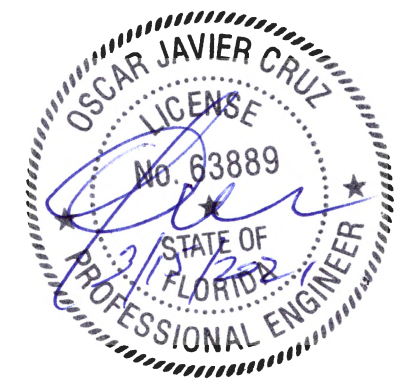

BRIDGE NO. 874474

REVISIONS					
DATE	BY	DESCRIPTION	DATE	BY	DESCRIPTION



CHROME ENGINEERING, INC.  
 16650 N. KENDALL DR., SUITE 205  
 MIAMI FL, 33196  
 (305) 432-6826  
 OSCAR J. CRUZ, P.E. LICENSE # 63889

DESIGNED BY	NAME	DATE	DRAWN BY	NAME	DATE
JAC	JAC	06/22/2020	ML	ML	08/25/2020
OC	OC	11/05/2020	OC	OC	11/05/2020

MIAMI-DADE COUNTY  
 TRANSPORTATION & PUBLIC WORKS DTPW  
 701 NW 1ST COURT  
 MIAMI, FLORIDA 33136

B-12 STRUCTURAL TREATED TIMBER BILL OF MATERIALS  
 2 OF 2

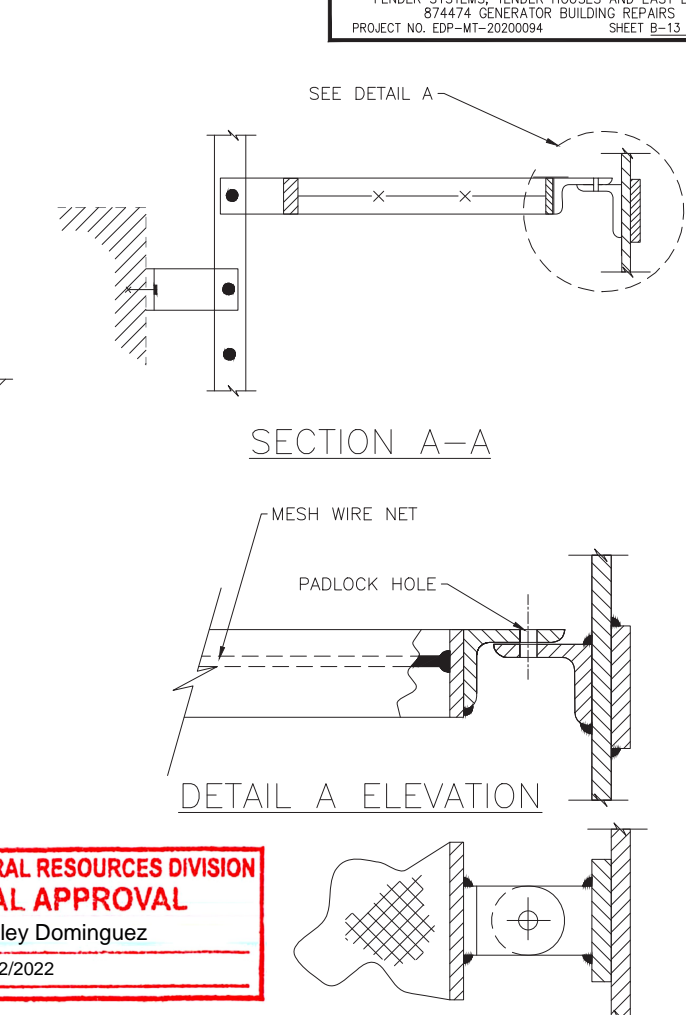
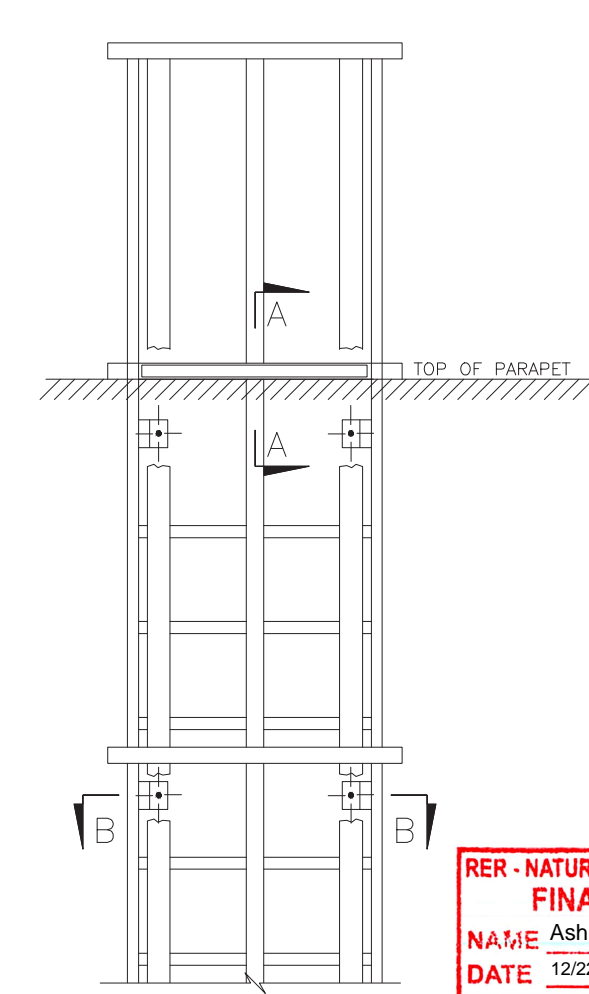
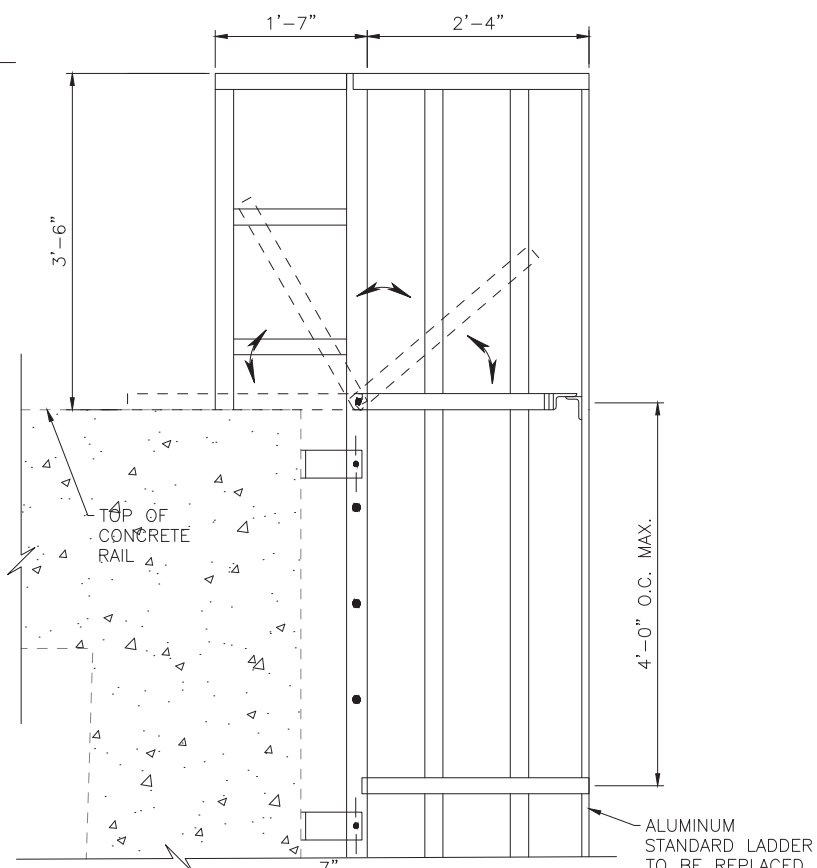
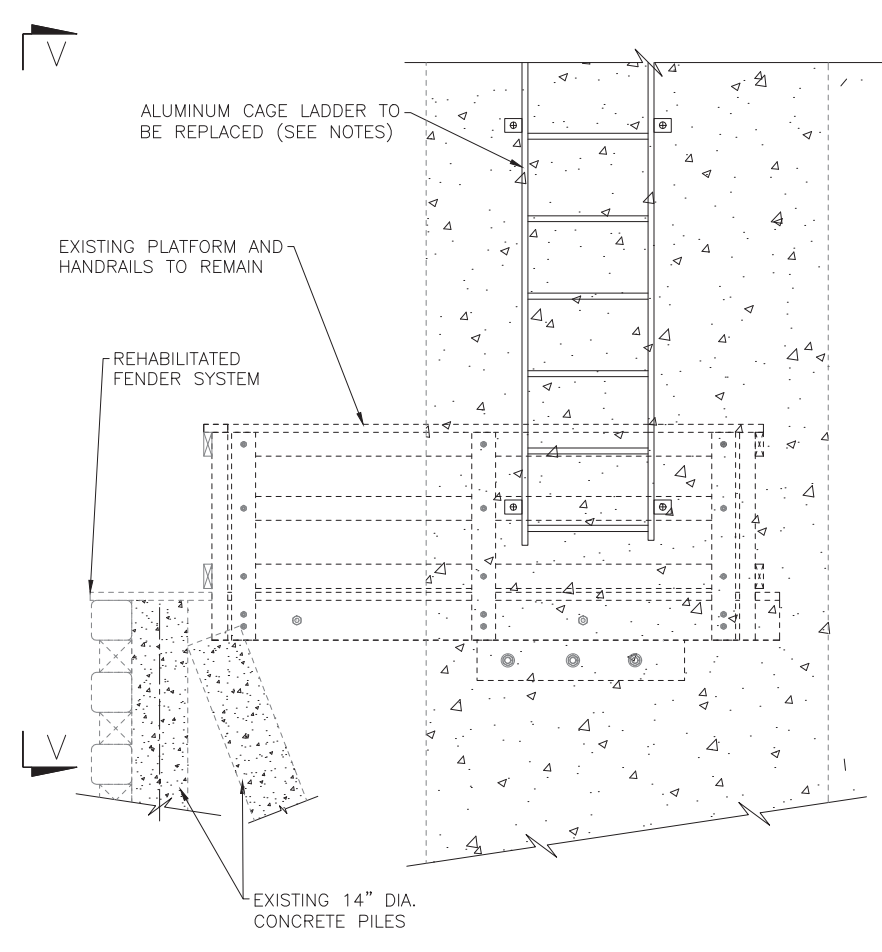

**RER - NATURAL RESOURCES DIVISION**  
**FINAL APPROVAL**  
 NAME Ashley Dominguez  
 DATE 12/22/2022

CROSS REFERENCE  
 SEE VIEW V LOCATION ON SHEET B-13.

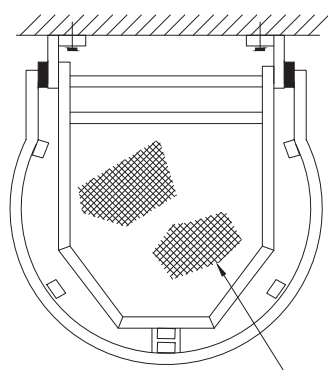

NOTES:

1. CONTRACTOR SHALL REMOVE AND REPLACE WITH A CAGE LADDER AT THE EXISTING DAMAGED LADDER LOCATED ON THE NW AND SE OF BRIDGES 874459 AND 874474.
2. CONTRACTOR SHALL EXERCISE EXTREME CAUTION NOT TO DAMAGE THE EXISTING LADDER PLATFORMS WHILE REMOVING THE DAMAGED LADDER. ANY DAMAGE CAUSED TO THE EXISTING PLATFORM AND HANDRAILS SHALL BE REPAIRED BY THE CONTRACTOR'S EXPENSES.
3. EXISTING PLATFORM SHOWN IS FOR BRIDGE 874459 ONLY.
4. CONTRACTOR SHALL SUBMIT SHOP DRAWINGS SIGNED & SEALED BY A FLORIDA LICENSED ENGINEER FOR THE NEW ALUMINUM CAGE LADDER INCLUDING CONNECTIONS WITH STAINLESS STEEL BOLTS TO EXISTING CONCRETE TO THE ENGINEER FOR REVIEW AND APPROVAL PRIOR TO FABRICATION. THE REAL FIELD DIMENSIONS SHALL BE INDICATED WITH AN (\*) ASTERISK IN THE SHOP DRAWINGS. ENSURE THAT LADDER DIMENSIONS ARE OSHA APPROVED.

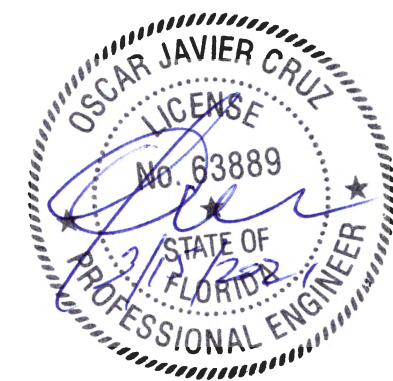

**RER - NATURAL RESOURCES DIVISION**  
**PRELIMINARY APPROVAL**  
 NAME Micaela Soldi  
 DATE 04/12/2021

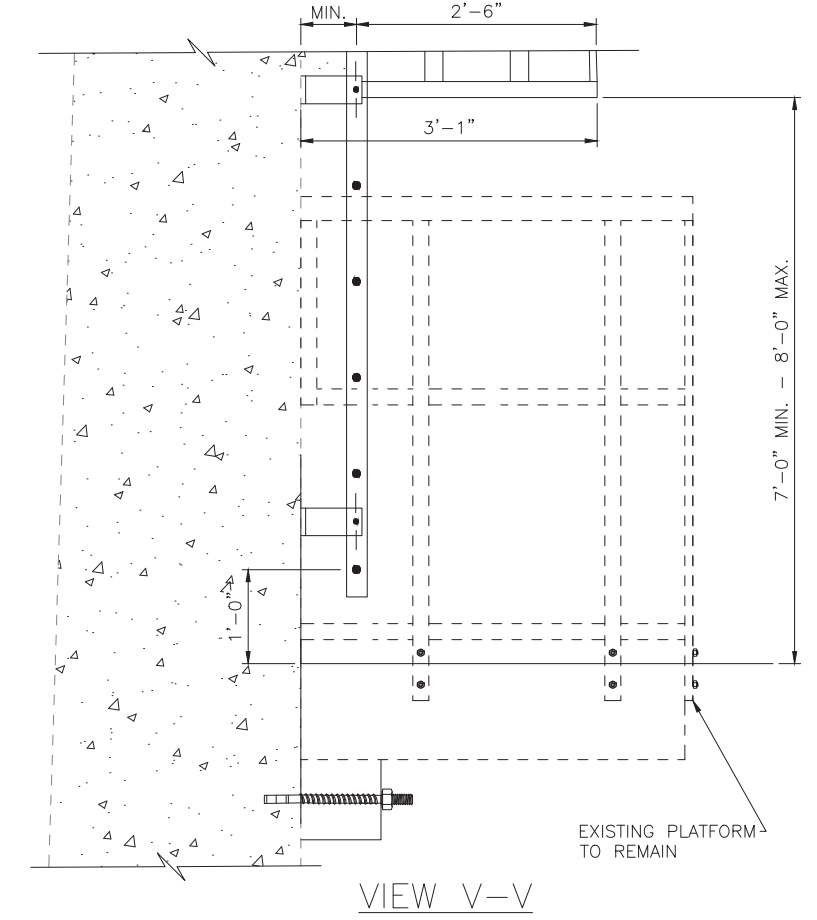
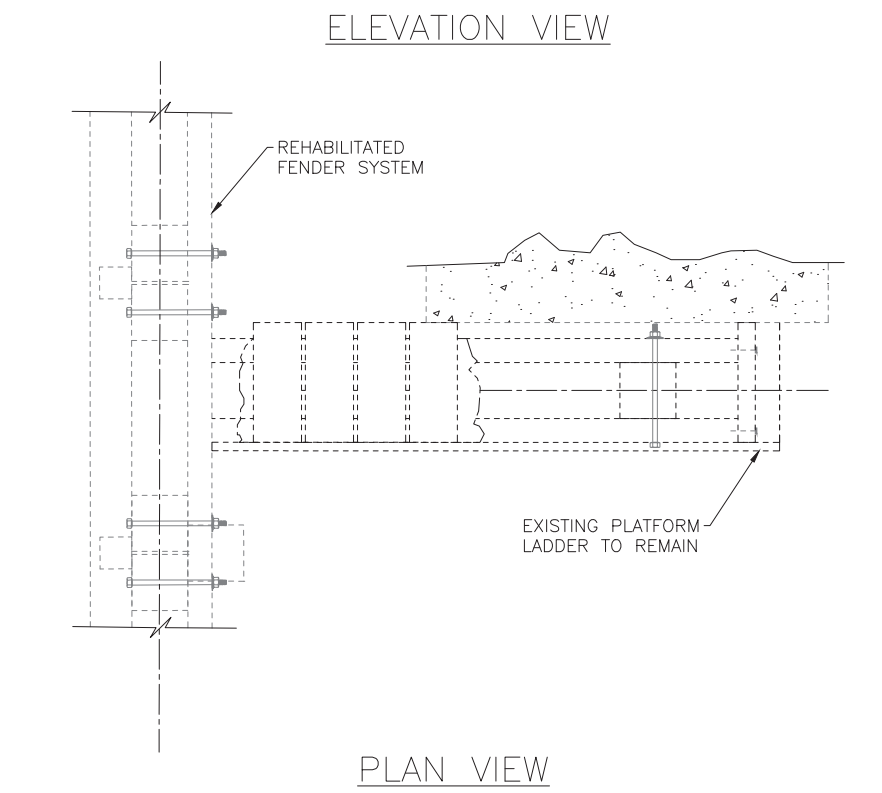

BRIDGE NO. 874459, 874474

C:\Users\mlemus\chrome\Engineering - Projects\20-13\700\_CADD\B13\_Ladder and Platform Details.dwg Mar. 15, 2021 - 12:41pm MLEMUS

REVISIONS					
DATE	BY	DESCRIPTION	DATE	BY	DESCRIPTION

**CHROME ENGINEERING, INC.**  
 16650 N. KENDALL DR., SUITE 205  
 MIAMI FL, 33196  
 (305) 432-6826  
 OSCAR J. CRUZ, P.E. LICENSE # 63889

NAME	DATE	NAME	DATE
DESIGNED BY JAC	06/22/2020	DRAWN BY ML	08/25/2020
CHECKED BY OC	11/05/2020	CHECKED BY OC	11/05/2020

MIAMI-DADE COUNTY  
 TRANSPORTATION & PUBLIC WORKS DTPW  
 701 NW 1ST COURT  
 MIAMI, FLORIDA 33136

B-13 LADDER AND PLATFORM DETAILS

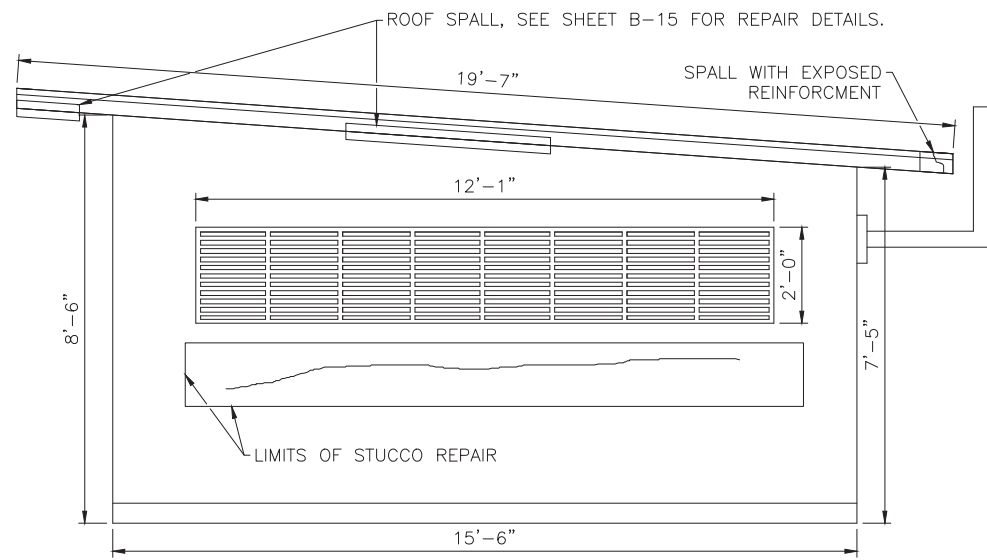

SOUTH ELEVATION

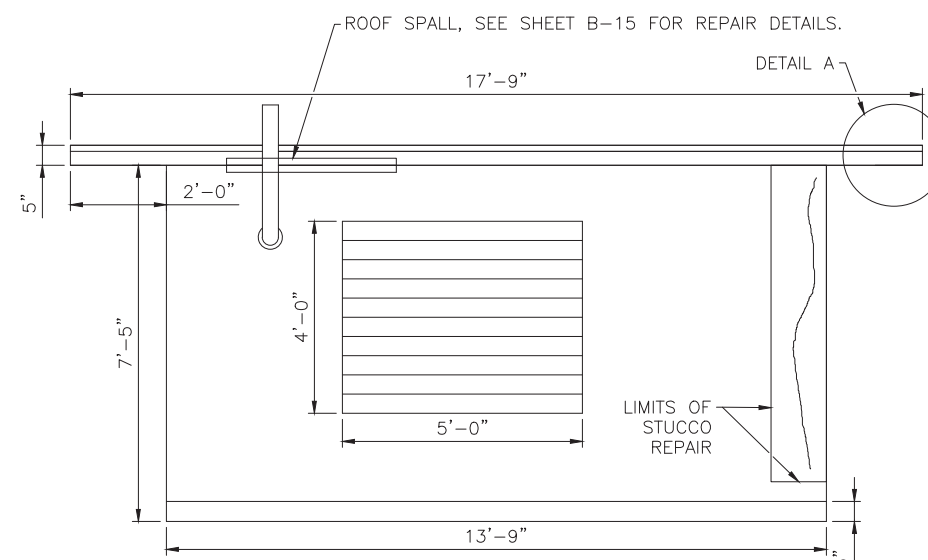

EAST ELEVATION

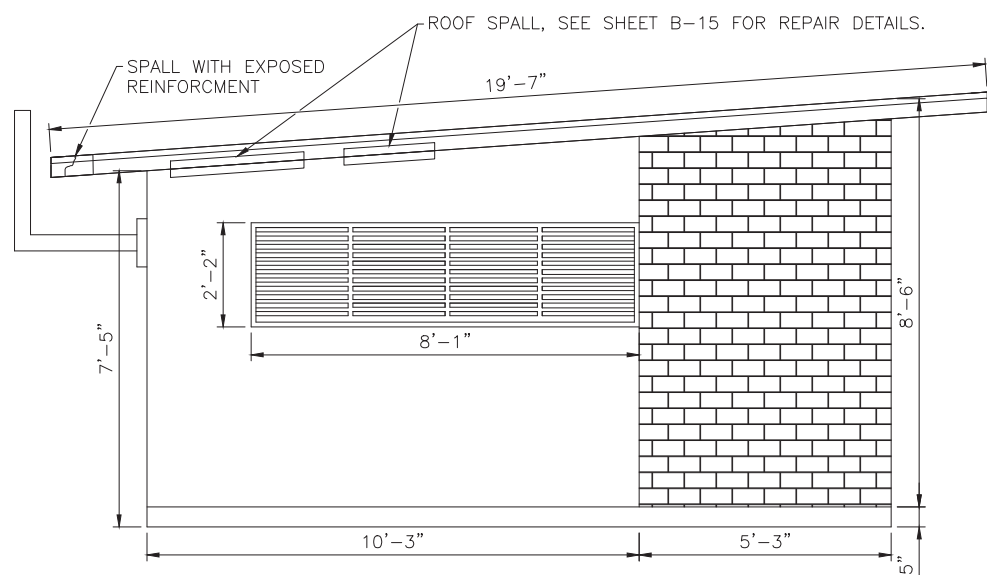

NORTH ELEVATION

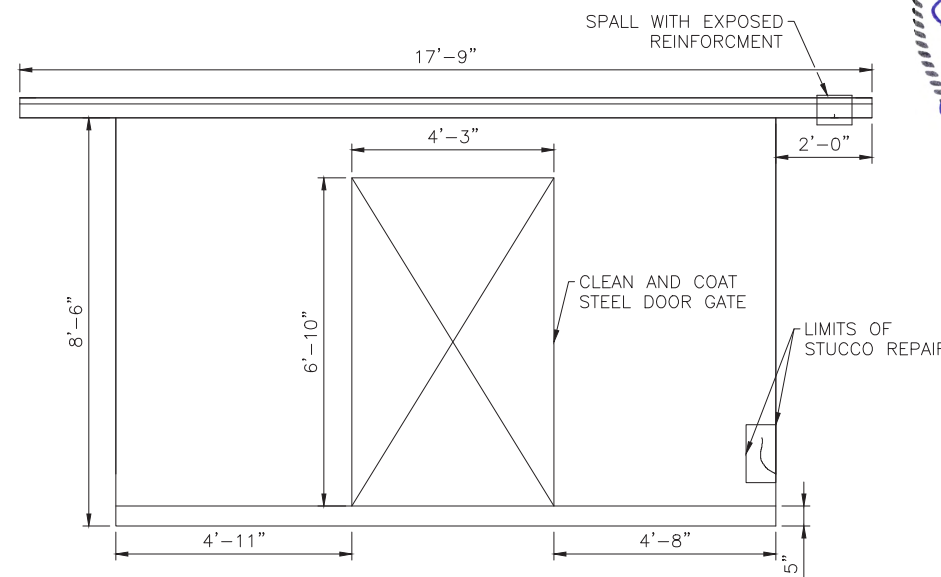

WEST ELEVATION

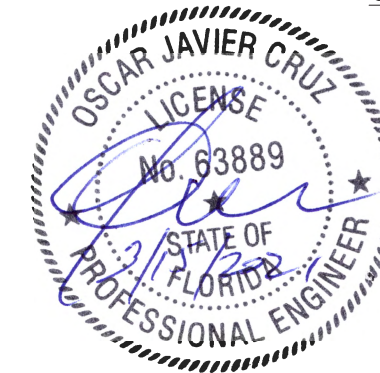

SPALL DAMAGE EXHIBIT  
(NE CORNER)



STUCCO DAMAGE EXHIBIT  
(NE CORNER)

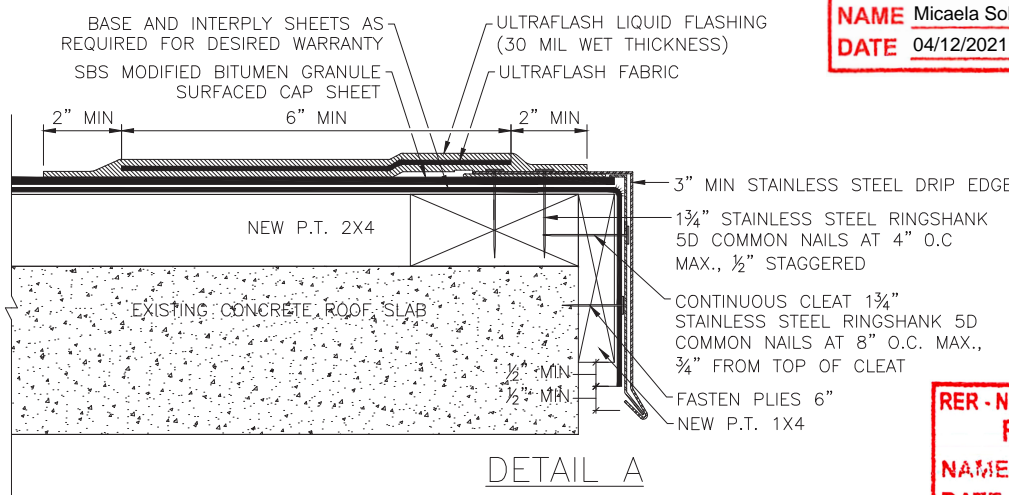

DETAIL A

**RER - NATURAL RESOURCES DIVISION  
 PRELIMINARY APPROVAL**  
 NAME Micaela Soldi  
 DATE 04/12/2021

NOTES:

1. NEW "MODIFIED BITUMEN ROOF SYSTEM OVER CONCRETE DECK" NOA 16-0202.10 OR A/E APPROVED EQUAL.
2. WOOD NAILERS MUST BE INSTALLED WITH SUITABLE FASTENERS TO MEET APPLICABLE BUILDING CODES (200 LBS PER LINEAR FOOT MIN IN ANY GIVEN DIRECTION).
3. GRANULES MUST BE EMBEDDED WHEN THERMALLY FUSING GRANULE SURFACED CAP SHEET.

**RER - NATURAL RESOURCES DIVISION  
 FINAL APPROVAL**  
 NAME Ashley Dominguez  
 DATE 12/22/2022

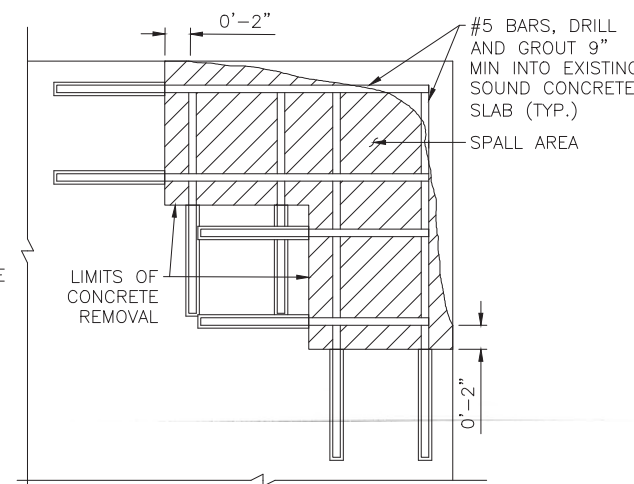

DETAIL B  
(NE CORNER SHOWN, SE CORNER SIMILAR)

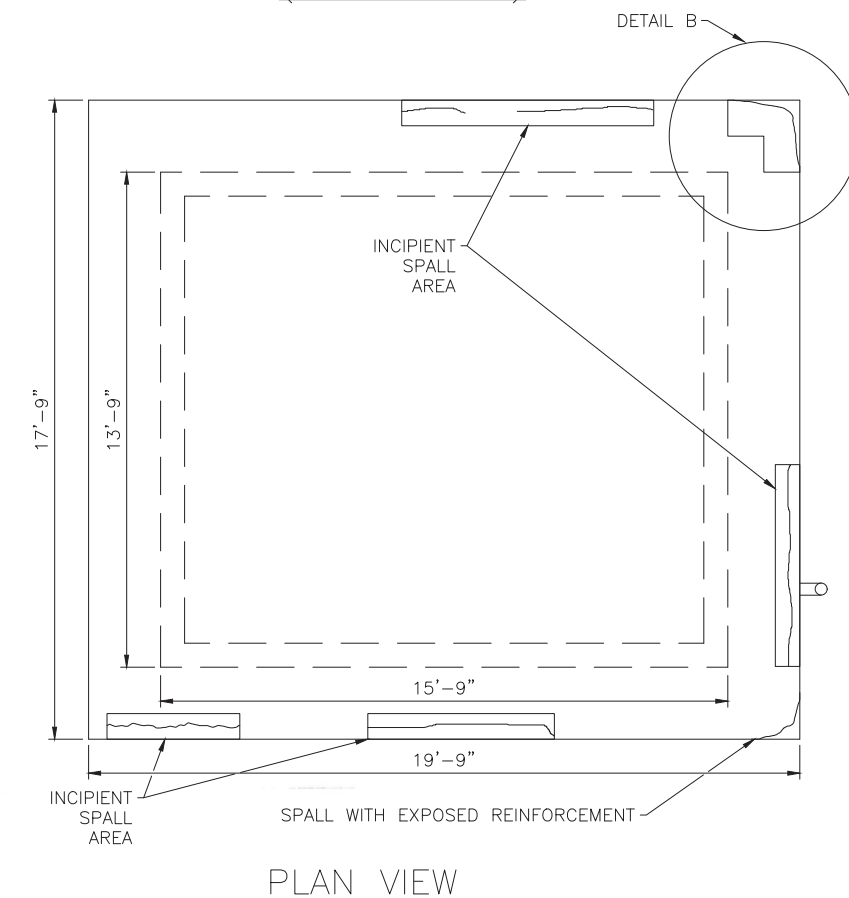

PLAN VIEW

BRIDGE NO. 874474

C:\Users\mlemus\chromeeng.com\Chrome Engineering - Projects\20-13\700\_CADD\15 B14\_Generator Building - B-14.dwg Mar 15, 2021 - 12:42pm MLEMUS



CHROME ENGINEERING, INC.  
 16650 N. KENDALL DR., SUITE 205  
 MIAMI FL, 33196  
 (305) 432-6826  
 OSCAR J. CRUZ, P.E. LICENSE # 63889

DESIGNED BY	NAME	DATE	DRAWN BY	NAME	DATE
JAC	JAC	06/22/2020	ML	ML	08/25/2020
CHECKED BY	OC	11/05/2020	CHECKED BY	OC	11/05/2020



TRANSPORTATION & PUBLIC WORKS DTPW  
 701 NW 1ST COURT  
 MIAMI, FLORIDA 33136

B-14

GENERATOR BUILDING REPAIR DETAILS



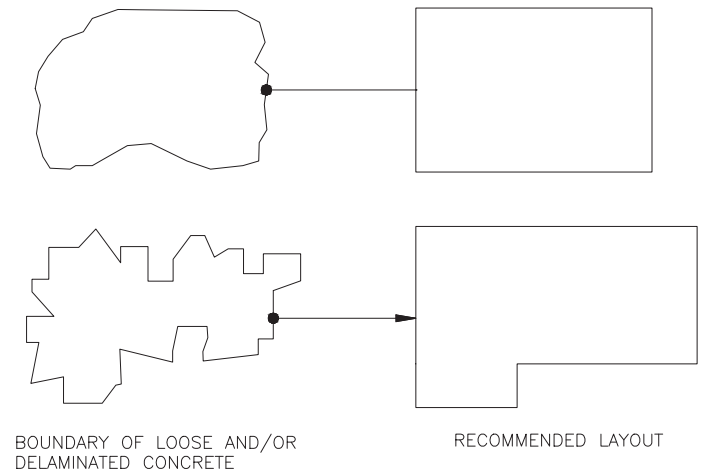
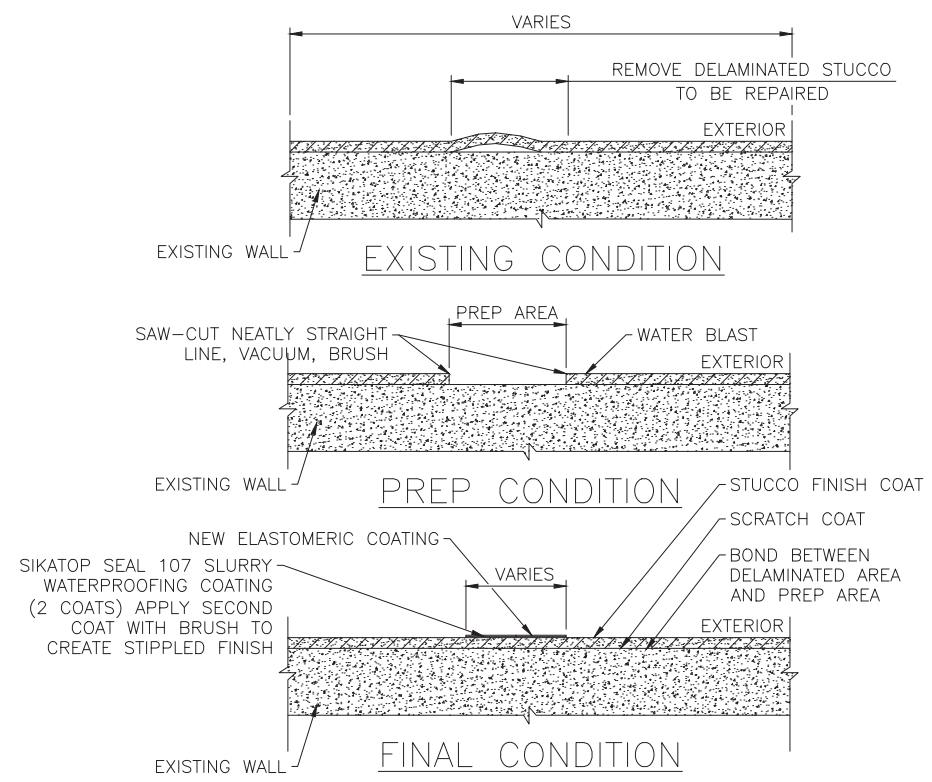

**TYPICAL SPALL/DELAMINATION REPAIR CONFIGURATIONS**

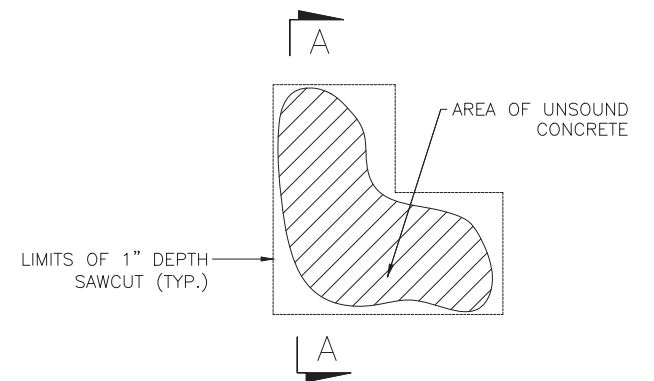

**PARTIAL DEPTH REPAIR PLAN**

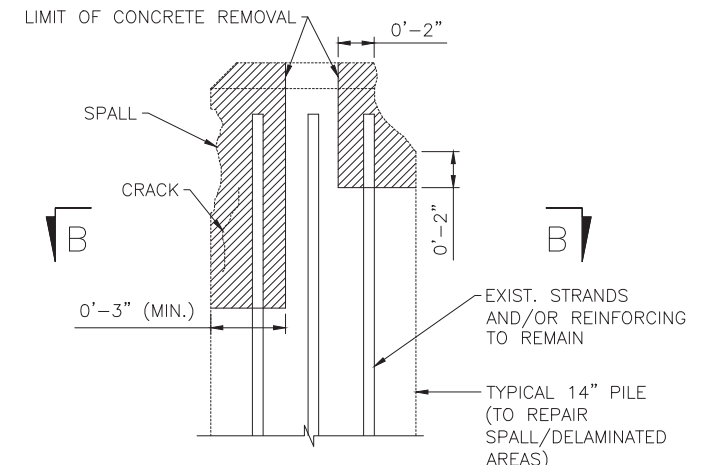

**SPALL CONCRETE PILE REPAIR DETAIL**

(REPAIR SPALL/DELAMINATED AREAS)

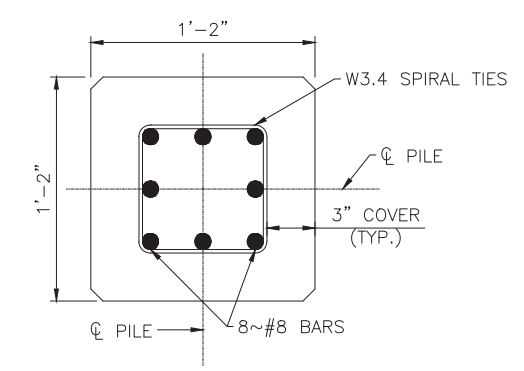

**SECTION B-B**

**STUCCO REPAIR NOTES PROCEDURE:**

- REMOVE EXISTING CRACKED AND LOOSE STUCCO INTO THE AREA BY 2" WHERE THE STUCCO IS SOLIDLY ADHERED.
  - CALL FOR ENGINEER'S INSPECTION IF BLOCK OR CONCRETE UNDER STUCCO IS CRACKED OR SPALLING REPAIR IS NEEDED.
  - BLOCK CRACKS ARE TO BE REPAIRED WITH SIKADUR 32, SIKAQUICK VOH, OR APPROVED EQUAL. IF WALL SURFACE IS BROKEN, CLEAN WALL OF LOOSE MATERIALS TO PROVIDE SOUND CONTACT FOR REPAIR PRODUCT. IF HAIRLINE CRACKS ARE PRESENT REPAIR AS PER SIKA 223 OR APPROVED EQUAL FOLLOWING THE MANUFACTURER'S RECOMMENDATIONS.
  - IF WALL CRACKS ARE PRESENT, COVER THE LENGTH OF CRACKS IN GALVANIZED MESH LATH USING 1/4"x2" LONG TAPCONS @ 6" O.C.
  - PRESSURE WASH EXISTING EXTERIOR WALLS TO RECEIVE NEW STUCCO REPAIRS AS SHOWN IN SHEET B-14.
  - REPLACE ALL EXISTING CAULK AROUND ALL EXTERIOR EXISTING DOORS AND WINDOWS WITH SIKAFLEX 15 LM OR EQUALLY APPROVED. CLEAN SURFACE AND APPLY SEALANT IN UNIFORM MANNER TO GIVE A CLEAN FINISH. INSTALL PER MANUFACTURER'S RECOMMENDATIONS.
  - CLEAN SURFACES OF ALL DIRT, DUST OR OTHER CONTAMINANTS THAT AFFECT ADHESION FOR PAINT OR APPEARANCE OF PAINT.
  - PAINT ALL EXTERIOR WALLS WITH ELASTOMERIC PAINT SUCH AS BEHR PREMIUM, ELATO HERIC, SHERWIN-WILLIAMS "SHERLASTIC", OR PITTSBURGH "MANOR TIMELESS SUPER ELASTOMERIC".
    - 1ST. COAT ACRYLIC PRIMER-SEALER OR OIL-BASE TRANSITION PRIMER SEALER.
    - 2ND. COAT ELASTOMERIC WATERPROOFER.
    - 3RD. COAT ELASTOMERIC WATERPROOFER.
- A. MINIMUM THICKNESS OF DRY FILM SHALL BE 5 MILS.  
 B. PAINT SHALL BE APPLIED WITH ROLLER AND BRUSH. SPRAY PAINT IS NOT ALLOWED.  
 C. COLOR SELECTION TO BE CONDUCTED BY MIAMI-DADE COUNTY PUBLIC WORKS DEPARTMENT.

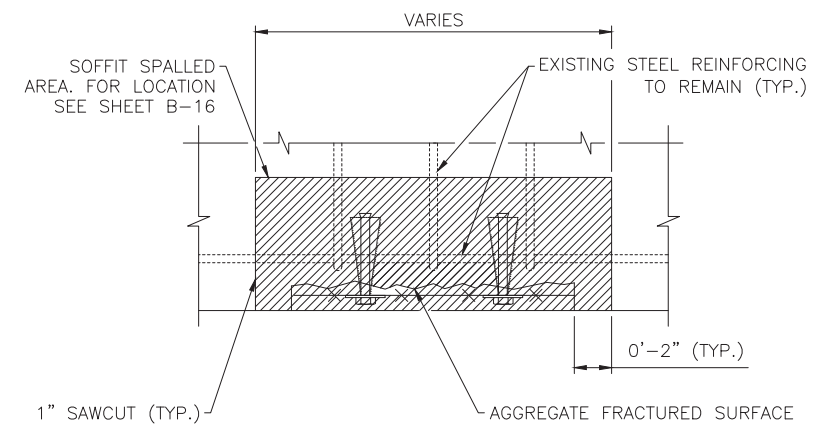

**ROOF SPALL REPAIR DETAIL**

(FOR SPALL/DELAMINATION REPAIR PROCEDURE, SEE GENERAL NOTES SHEET B-4)

**RER - NATURAL RESOURCES DIVISION**  
**FINAL APPROVAL**  
 NAME Ashley Dominguez  
 DATE 12/22/2022

**RER - NATURAL RESOURCES DIVISION**  
**PRELIMINARY APPROVAL**  
 NAME Micaela Soldi  
 DATE 04/12/2021

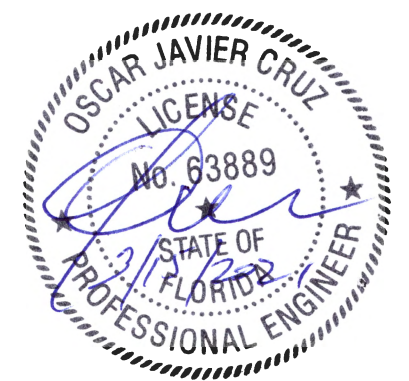

BRIDGE NO. 874474

REVISIONS					
DATE	BY	DESCRIPTION	DATE	BY	DESCRIPTION

CHROME ENGINEERING, INC.  
 16650 N. KENDALL DR., SUITE 205  
 MIAMI FL, 33196  
 (305) 432-6826  
 OSCAR J. CRUZ, P.E. LICENSE # 63889

NAME	DATE	NAME	DATE
DESIGNED BY JAC	06/22/2020	DRAWN BY ML	08/25/2020
CHECKED BY OC	11/05/2020	CHECKED BY OC	11/05/2020

MIAMI-DADE COUNTY  
 TRANSPORTATION & PUBLIC WORKS DTPW  
 701 NW 1ST COURT  
 MIAMI, FLORIDA 33136

B-15

REPAIR DETAILS

C:\Users\mlemus\chromeeng.com\Chrome Engineering - Projects\20-13\700\_CADD\16 B15\_Spall Repair Details B-15.dwg Mar 15, 2021 - 12:42pm MLEMUS

GENERAL NOTES

ELECTRICAL AND CONTROL SCOPE OF WORK.

- NAVIGATION LIGHTS AND AIDS.
  - FURNISH AND INSTALL NEW FENDER NAVIGATIONAL LIGHTS AND CLEARANCE GAUGE LIGHTS. ALL LIGHTS SHALL BE LED.
  - FURNISH AND INSTALL NEW PVC COATED RIGID GALVANIZED STEEL CONDUIT AND J-BOXES FOR ALL NEW NAVIGATIONAL LIGHTING INSTALLATION.
- CONDUIT AND WIRING.
  - THE CONTRACTOR SHALL FURNISH AND INSTALL ALL NEW CONDUIT, WIRES AND CABLES REQUIRED TO COMPLETE THE INSTALLATION AS INDICATED ON THE PLANS. ALL CONDUITS SHALL BE PVC COATED RIGID GALVANIZED METAL CONDUIT TYPE UNLESS OTHERWISE SPECIFIED. THE WIRING SHALL BE OF TYPE AND QUANTITY AS SHOWN ON THE PLANS.
  - THE CONTRACTOR SHALL BE RESPONSIBLE FOR FURNISHING ALL REQUIRED CONDUIT AND CONDUIT SUPPORT IN ACCORDANCE WITH THE PLANS. THE COST FOR CONDUIT SUPPORT SHALL BE INCLUDED WITH THE COST OF THE CONDUIT SYSTEM. CONDUIT SUPPORT DETAILS AND LOCATIONS SHALL BE SUBMITTED TO THE ENGINEER FOR REVIEW AND APPROVAL.
- BRIDGE GROUNDING SYSTEM
  - THIS WORK CONSISTS OF REPAIRING, INSTALLING AND PLACE EXISTING BRIDGE PIER (NEAR AND FAR) (WEST VENETIAN). GROUNDING AND BONDING SYSTEM IN FULL OPERATING SERVICE. INCLUDE DOWNLEADS, MAIN CONDUCTORS, GROUND RODS, FLEXIBLE BONDING STRAPS, ETC. FOR A COMPLETE SYSTEM REHABILITATION.
  - IT IS THE RESPONSIBILITY OF THE CONTRACTOR TO PERFORM A SITE VISIT TO ACCESS BRIDGE GROUNDING SYSTEM ADJACENT TO THE FENDER SYSTEM PRIOR TO FURNISHING A BID PRICE.

ELECTRICAL GENERAL NOTES.

- CONFORM TO ALL NEC, NFPA, UL, IEEE AND NEMA STANDARDS AND PRACTICES.
- ELECTRICAL DEVICES AND EQUIPMENT ARE SHOWN SYMBOLICALLY ON THE PLANS. THE USE OF SYMBOLS AND NOTATIONS (OR THE OMISSION THEREOF) DO NOT RELIEVE THE CONTRACTOR FROM FURNISHING A SAFE, COMPLETE AND FULLY FUNCTIONAL SYSTEM. FIELD LOCATE DEVICES AND EQUIPMENT TO FACILITATE ACCESSIBILITY WITH RESPECT TO OPERATIONS AND MAINTENANCE CONDITIONS.
- ALL MOUNTING HARDWARE SHALL BE 316 SERIES STAINLESS STEEL AND/OR PVC COATED.
- MINIMUM CONDUIT SIZE IS 1". ALL WIRES SHALL BE THWN/MTW UNLESS OTHERWISE NOTED. MINIMUM WIRE SIZE IS #12 AWG FOR POWER.

**RER - NATURAL RESOURCES DIVISION  
 PRELIMINARY APPROVAL**  
 NAME Micaela Soldi  
 DATE 04/12/2021

**RER - NATURAL RESOURCES DIVISION  
 FINAL APPROVAL**  
 NAME Ashley Dominguez  
 DATE 12/22/2022

LEGEND

ONE-LINE DIAGRAM

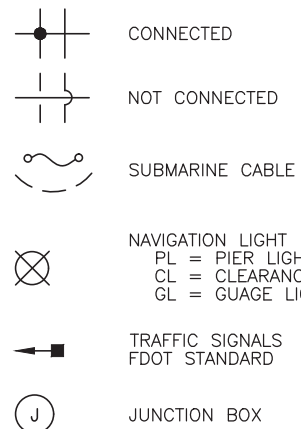

DEVICES

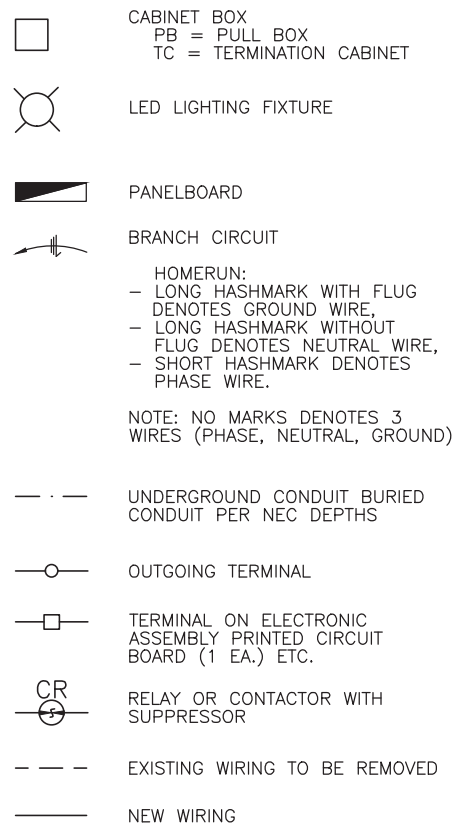

ABBREVIATIONS

ABBR.	ABBREVIATION	MACH.	MACHINERY
ADDR.	ADDRESS	MAN.	MANUAL
ADJ.	ADJACENT	MAX.	MAXIMUM
AFCI	ARC FAULT CIRCUIT INTERRUPTER	MCB	MOLDED CIRCUIT BREAKER
AFF	ABOVE FINISHED FLOOR	MCC	MOTOR CONTROL CENTER
ALT	ALTERNATOR	MD	MAIN DISCONNECT
AMP.	AMPERE	MEC	MASSACHUSETTS ELECTRIC CODE
AM	AUX.MOTOR	MHT	MOTOR STRIP HEATER
APP.	APPLICABLE	MHW	MEAN HIGH WATER
ATS	AUTOMATIC TRANSFER SWITCH	MIN.	MINIMUM
ATTN	ATTENTION	MLW	MEAN LOW WATER
AUTO.	AUTOMATIC	NA	NEAR ADJACENT
AUX.	AUXILIARY	NAV.	NAVIGATION
AWG	AMERICAN WIRE GAGE	NC	NORMALLY CLOSED
BC	BRIDGE CONTROL	NEMA	NATIONAL ELECTRICAL MANUFACTURERS ASSOC.
BCR	BRIDGE CONTROL RELAY	NEWD	NEAR END WEDGE DOWN
BG	BARRIER GATE	NEWP	NEAR END WEDGE PULL
BRK.	BRAKE	NFPA	NATIONAL FIRE PREVENTION ASSOCIATION
BM	BUS MONITOR	NO.	NUMBER
C	CONDUIT	NO	NEAR OPPOSITE
CB	CIRCUIT BREAKER	NOC	NEAR ON-COMING
CC	CONTROL CONSOLE	NOG	NEAR OFF-GOING
CCTV	CLOSED-CIRCUIT TELEVISION	NSC	NEW SUBMARINE CABLE
cd	CANDELA	N.T.S	NOT TO SCALE
CMPT.	COMPARTMENT	NUM.	NUMBER
CP	CONTROL PANEL	OPP	OPPOSITE
CT	CURRENT TRANSFORMER	OL	OVERLOAD RELAY
CU	COMPRESSOR UNIT	OT	OVER-TRAVEL
DC	DIRECT CURRENT	P	PULLED
DIA.	DIAMETER	PA	PUBLIC ADDRESS
DISC.	DISCONNECT	PDP	POWER DISTRIBUTION PANEL
DISTR.	DISTRIBUTION	PLC	PROGRAMMABLE LOGIC CONTROLLER
DN.	DOWN	POT.	POTENTIOMETER
DPDT	DOUBLE POLE DOUBLE THROW	PT	POTENTIAL TRANSFORMER
DS	DISCONNECT SWITCH	PF	POWER FACTOR
DSL	DIGITAL SUBSCRIBER LINE	PP	POWER AND LIGHTING PANEL
DWG.	DRAWING	PRGS	PVC COATED RGS
DYN.	DYNAMIC	PVC	POLYVINYL CHLORIDE CONDUIT
ECOAST	EMERGENCY COAST	QTY.	QUANTITY
EF	EXHAUST FAN	RCP	REFLECTIVE CEILING PLAN
E.G.	ELECTRICAL GROUND	REC	RECEPTACLE
EH	ELECTRIC HORN	REL.	RELEASED
EMER.	EMERGENCY	RES	RESOLVER
ENCL.	ENCLOSURE	RLS	ROTARY LIMIT SWITCH
ENC.	ENCODER	RL	ROADWAY LIGHTING
E.O.L	END OF LINE	RNL	RED NAVIGATIONALL LIGHT
ETS	EMERGENCY TRAFFIC SIGNAL	RP	RECEPTACLES
EW	END WEDGE	RGS	RIGID GALVANIZED STEEL CONDUIT
FA	FAR ADJACENT	S	SPAN
FLC	FULL LOAD CURRENT	SC	SUBMARINE CABLE
FM	FACTORY MUTUAL	SEC.	SECOND
FOC	FAR ON-COMING	SHT	SHEET
FOG	FAR OFF-GOING	SPD	SURGE PROTECTION DEVICE
FU	FUSE	SPEC.	SPECIFICATION
FVNR	FULL VOLTAGE NON-REVERSING STARTER	SS	STAINLESS STEEL
FVR	FULL-VOLTAGE REVERSING STARTER	SUB.	SUBMARINE
FC	FAR INCOMING	SUP	SUPPRESSOR
FO	FAR OPPOSITE	SW.	SWITCH
GALV.	GALVANIZED	TG	TRAFFIC GATE
GFCI	GROUND FAULT CIRCUIT INTERRUPTER	THK.	THICK
GND.	GROUND	TS	TRANSFER SWITCH
HDG	HOT DIPPED GALVANIZED	TSP	TWISTED SHIELDED PAIR
HP	HORSEPOWER	TVSS	TRANSIENT VOLTAGE SURGE SUPPRESSOR
HZ	HERTZ	TYP.	TYPICAL
IND.	INDICATION	UL	UNDERWRITER'S LABORATORY
INDUS.	INDUSTRIAL	UPS	UNINTERRUPTIBLE POWER SUPPLY
JB	JUNCTION BOX	UVR	UNDER VOLTAGE RELAY
KVA	KILO-VOLT-AMPERE	V	VOLT
KW	KILOWATT	VENT.	VENTILATION
LC	LOCK CONTROL	VERT.	VERTICAL
LED	LIGHT EMITTING DIODES	VFD	VARIABLE FREQUENCY DRIVE
LS	LIMIT SWITCH	VM.	VOLTMETER
		W/	WITH
		W	WATT
		WH	WATT HOUR
		WM	WATT-HOUR METER
		WP	WATER PROTECTION COVER
		XFMR	TRANSFORMER CENTER LANE

NOTE NUMBER  
 EXX-XX  
 SHEET NUMBER

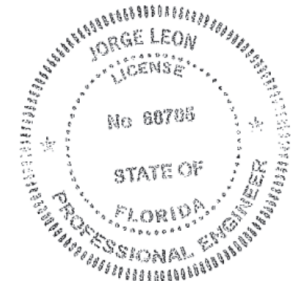

**JL** Digitally signed by JL  
 DN: C=US,  
 E=jorge.leon@stvinc.com,  
 O=STV Inc., CN=JL  
 Date: 2020.12.04  
 09:07:51-05'00'

BRIDGE NO. 874459 & 874474

I:\Projects\4020712\4020712\_0001\90\_CAD Models and Sheets\14\_Electrical\BE01 - Symbols Abbreviations and Notes.dwg Jul 14, 2020 - 12:25pm PERERAM

REVISIONS							
DATE	BY	DESCRIPTION	DATE	BY	DESCRIPTION	DATE	BY

STV INCORPORATED 6303 BLUE LAGOON DR.  
 SUITE 400 | MIAMI FL, 33126  
 (305)537-4673 FAX: (305)751-5311  
 JORGE LEON  
 FL. LICENSE # 68705

DESIGNED BY	NAME	DATE	DRAWN BY	NAME	DATE
JL	JL	06/22/2020	MPS	MPS	06/24/2020
MPS	MPS	06/30/2020	JL	JL	06/30/2020

DEPARTMENT OF TRANSPORTATION AND PUBLIC WORKS  
 HIGHWAY DIVISION  
 STEPHEN P. CLARK CENTER  
 11 NW 1 ST  
 MIAMI, FLORIDA 33128

BE-01 SYMBOLS, ABBREVIATIONS AND GENERAL NOTES

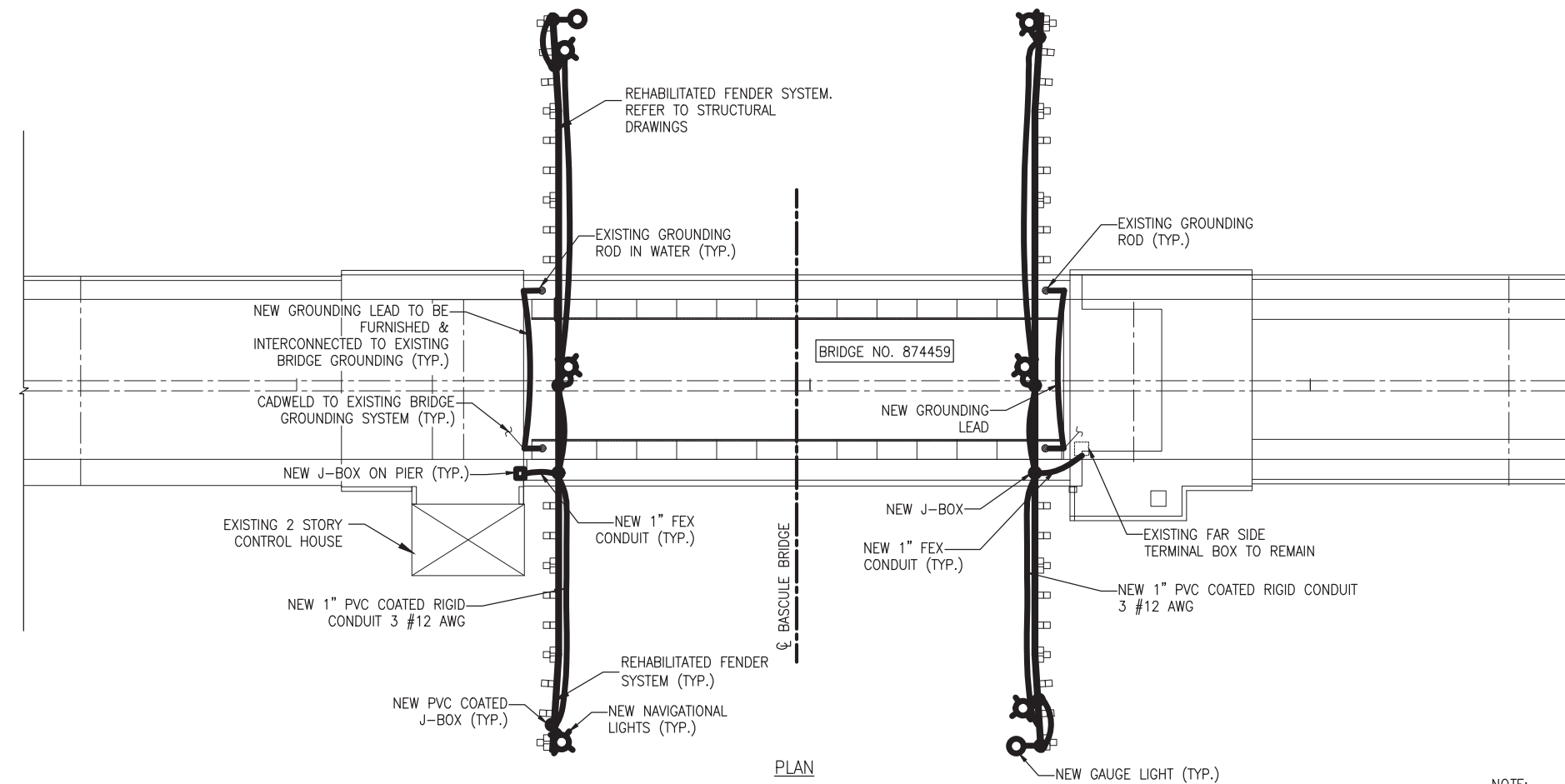

PLAN

NOTE:

ALL ELEMENTS SHOWN ON THIS SHEET ARE EXISTING UNLESS OTHERWISE NOTED AND BASED ON INFORMATION OBTAINED FROM EXISTING DRAWINGS AND LIMITED FIELD INVESTIGATION. SCOPE OF WORK OF THE ELECTRICAL WORK IS TO REPLACE THE FENDER NAVIGATIONAL AIDS AND ASSOCIATED CONDUITS, WIRES AND JUNCTION BOXES

ABBREVIATION:

F.F. = FRONT FACE

**RER - NATURAL RESOURCES DIVISION  
 PRELIMINARY APPROVAL**  
 NAME Micaela Soldi  
 DATE 04/12/2021

**RER - NATURAL RESOURCES DIVISION  
 FINAL APPROVAL**  
 NAME Ashley Dominguez  
 DATE 12/22/2022

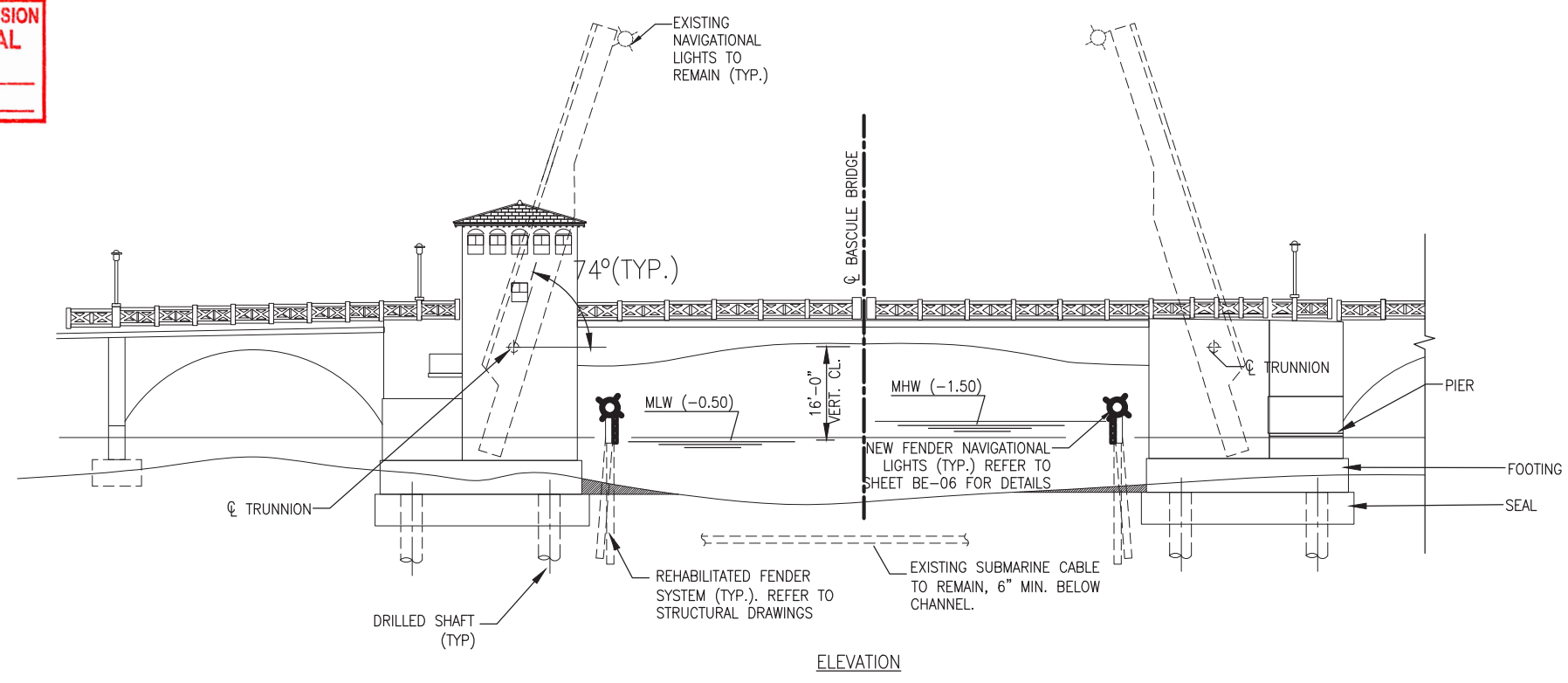

ELEVATION

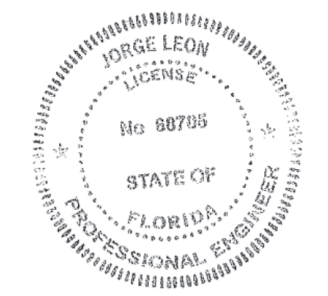

Digitally signed by JL  
 DN: C=US,  
 E=jorge.leon@stvinc.com,  
 O=STV Inc., CN=JL  
 Date: 2020.12.04  
 09:08:33-05'00'

BRIDGE NO. 874459

I:\Projects\4020712\4020712\_0001\90\_CAD Models and Sheets\14\_Electrical\BE02- Plan and Elevation West.dwg Jul 15, 2020 - 3:16pm PERERAM

REVISIONS					
DATE	BY	DESCRIPTION	DATE	BY	DESCRIPTION

STV INCORPORATED 6303 BLUE LAGOON DR.  
 SUITE 400 | MIAMI FL, 33126  
 (305)537-4673 FAX: (305)751-5311  
 JORGE LEON  
 FL. LICENSE # 68705

DESIGNED BY	JL	DATE	06/22/2020	DRAWN BY	MPS	DATE	06/24/2020
CHECKED BY	MPS	DATE	06/30/2020	CHECKED BY	JL	DATE	06/30/2020
SUPERVISED BY							

DEPARTMENT OF TRANSPORTATION AND PUBLIC WORKS  
 HIGHWAY DIVISION  
 STEPHEN P. CLARK CENTER  
 111 NW 1 ST  
 MIAMI, FLORIDA 33128

BE-02  
 PLAN AND ELEVATION  
 WEST VENETIAN BRIDGE

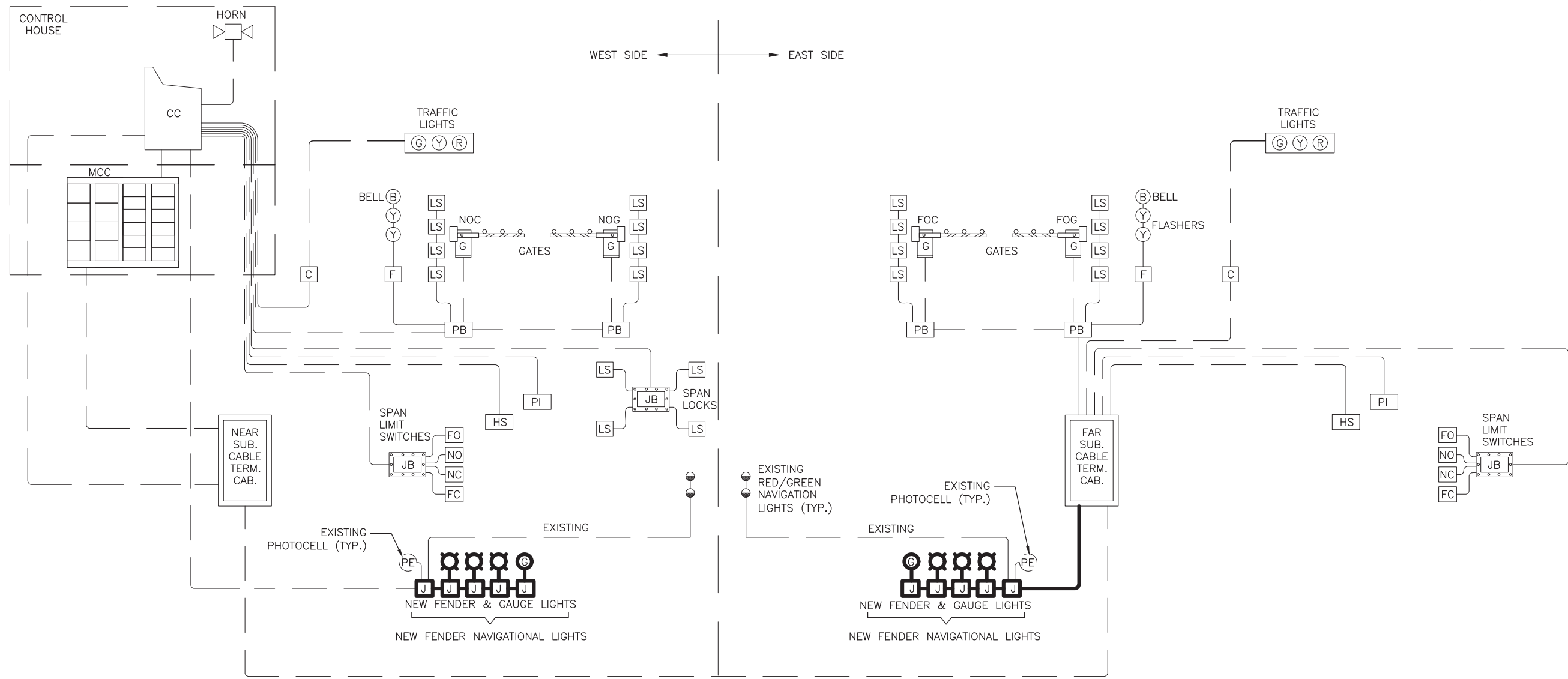

**RER - NATURAL RESOURCES DIVISION  
 PRELIMINARY APPROVAL**  
 NAME Micaela Soldi  
 DATE 04/12/2021

**RER - NATURAL RESOURCES DIVISION  
 FINAL APPROVAL**  
 NAME Ashley Dominguez  
 DATE 12/22/2022

**LEGEND**

- CONTROL CONSOLE
- MOTOR CONTROL CENTER
- LIMIT SWITCH
- EXISTING PULL BOX
- EXISTING CONDUIT
- NEW CONDUIT
- POSITION INDICATOR
- NEW JUNCTION BOX
- EXISTING PHOTOELECTRIC CELL

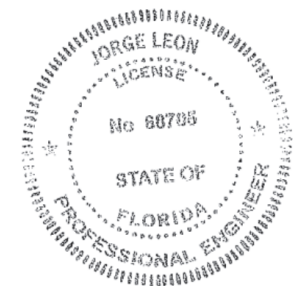

**JL**  
 Digitally signed by JL  
 DN: G=US,  
 E=jorge.leon@stvinc.com,  
 O=STV Inc., CN=JL  
 Date: 2020.12.04  
 09:36:27 -0500

BRIDGE NO. 874459

REVISIONS					
DATE	BY	DESCRIPTION	DATE	BY	DESCRIPTION

STV INCORPORATED 6303 BLUE LAGOON DR. SUITE 400   MIAMI FL, 33126 (305)537-4673 FAX: (305)751-5311 JORGE LEON FL. LICENSE # 68705					
DESIGNED BY	JL	DATE	06/22/2020	DRAWN BY	MPS
CHECKED BY	MPS	DATE	06/30/2020	CHECKED BY	JL
SUPERVISED BY		DATE	06/30/2020		

DEPARTMENT OF TRANSPORTATION AND PUBLIC WORKS  
 HIGHWAY DIVISION  
 STEPHEN P. CLARK CENTER  
 111 NW 1 ST  
 MIAMI, FLORIDA 33128

BE-03 BRIDGE CONDUIT DIAGRAM  
 WEST VENETIAN

I:\Projects\4020712\4020712\_0001\90\_CAD Models and Sheets\14\_Electrical\BE03- Control Riser Diagram West.dwg Jul 15, 2020 - 3:18pm PERERAM

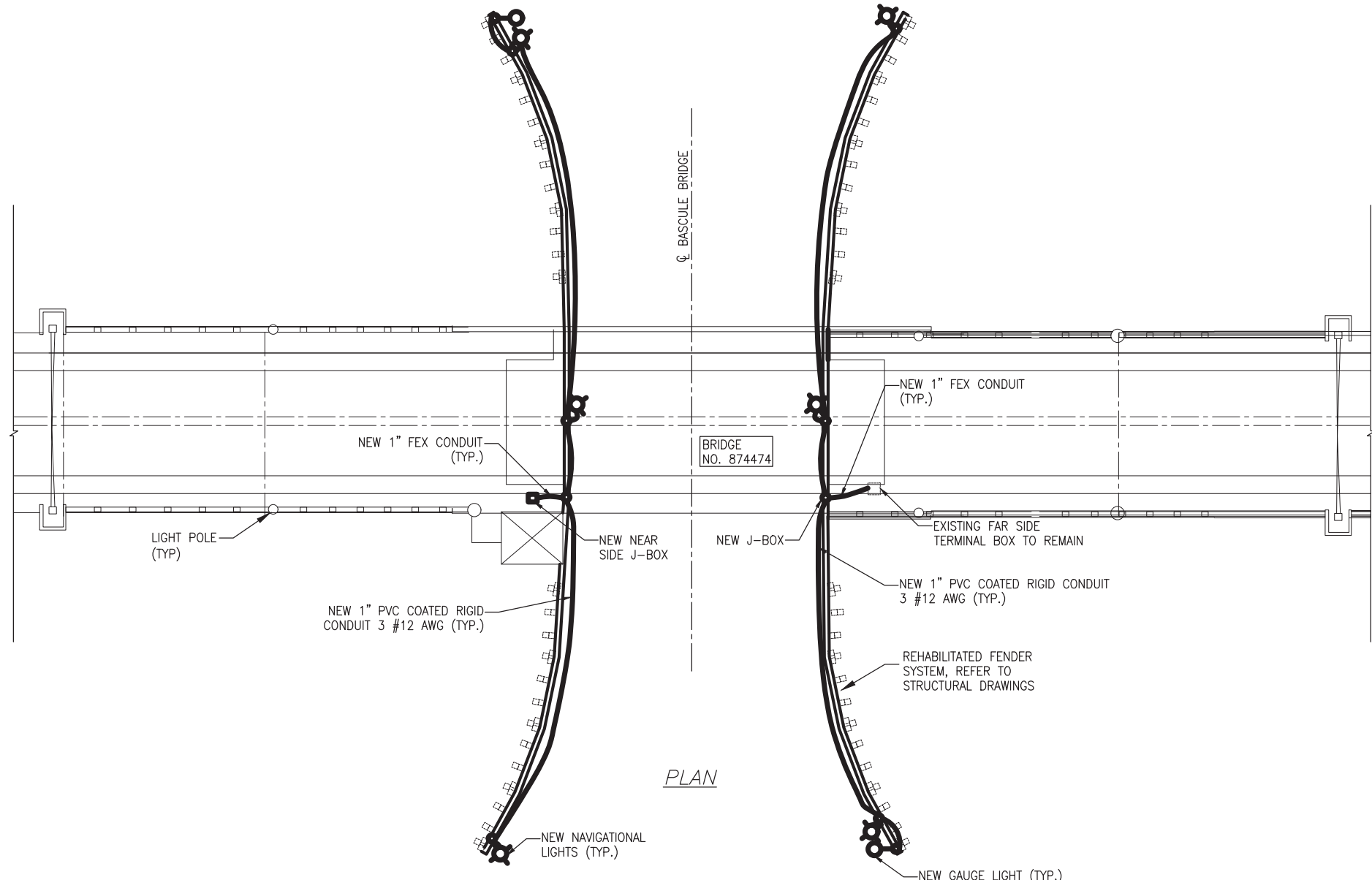

**RER - NATURAL RESOURCES DIVISION  
 FINAL APPROVAL**  
 NAME Ashley Dominguez  
 DATE 12/22/2022

**RER - NATURAL RESOURCES DIVISION  
 PRELIMINARY APPROVAL**  
 NAME Micaela Soldi  
 DATE 04/12/2021

**NOTE:**  
 ALL ELEMENTS SHOWN ON THIS SHEET ARE EXISTING UNLESS OTHERWISE NOTED AND BASED ON INFORMATION OBTAINED FROM EXISTING DRAWINGS AND LIMITED FIELD INVESTIGATION. SCOPE OF WORK OF THE ELECTRICAL WORK IS TO REPLACE THE FENDER NAVIGATIONAL AIDS AND ASSOCIATED CONDUITS, WIRES AND JUNCTION BOXES.

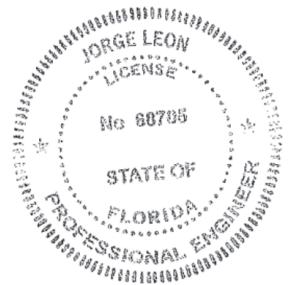
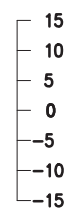
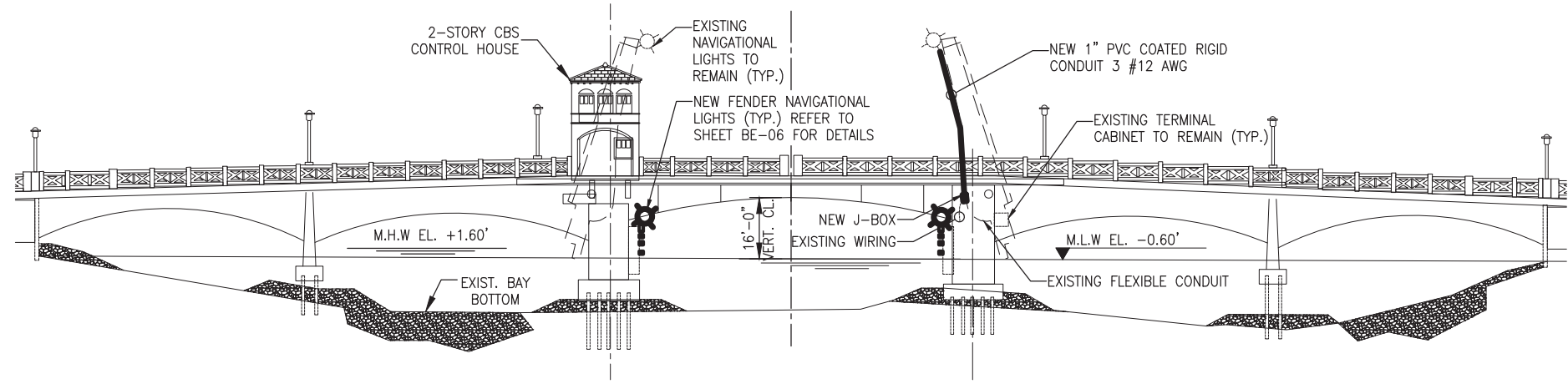

**JL**  
 Digitally signed by JL  
 DN: C=US,  
 E=jorge.leon@stvinc.com,  
 O=STV Inc., CN=JL  
 Date: 2020.12.04  
 09:09:53-0500'

BRIDGE NO. 874474

REVISIONS					
DATE	BY	DESCRIPTION	DATE	BY	DESCRIPTION

**STV**  
 STV INCORPORATED 6303 BLUE LAGOON DR.  
 SUITE 400 | MIAMI FL, 33126  
 (305)537-4673 FAX: (305)751-5311  
 JORGE LEON  
 FL. LICENSE # 68705

DESIGNED BY	NAME	DATE	DRAWN BY	NAME	DATE
JL	JL	06/22/2020	MPS	MPS	06/24/2020
CHECKED BY	MPS	06/30/2020	CHECKED BY	JL	06/30/2020
SUPERVISED BY:					

**MIAMI-DADE COUNTY**  
 DEPARTMENT OF TRANSPORTATION AND PUBLIC WORKS  
 HIGHWAY DIVISION  
 STEPHEN P. CLARK CENTER  
 111 NW 1 ST  
 MIAMI, FLORIDA 33128

BE-04  
 PLAN AND ELEVATION  
 EAST VENETIAN BRIDGE

I:\Projects\4020712\4020712\_0001\90\_CAD Models and Sheets\14\_Electrical\BE04- Plan and Elevation East.dwg Jul 15, 2020 - 3:39pm PERERAM

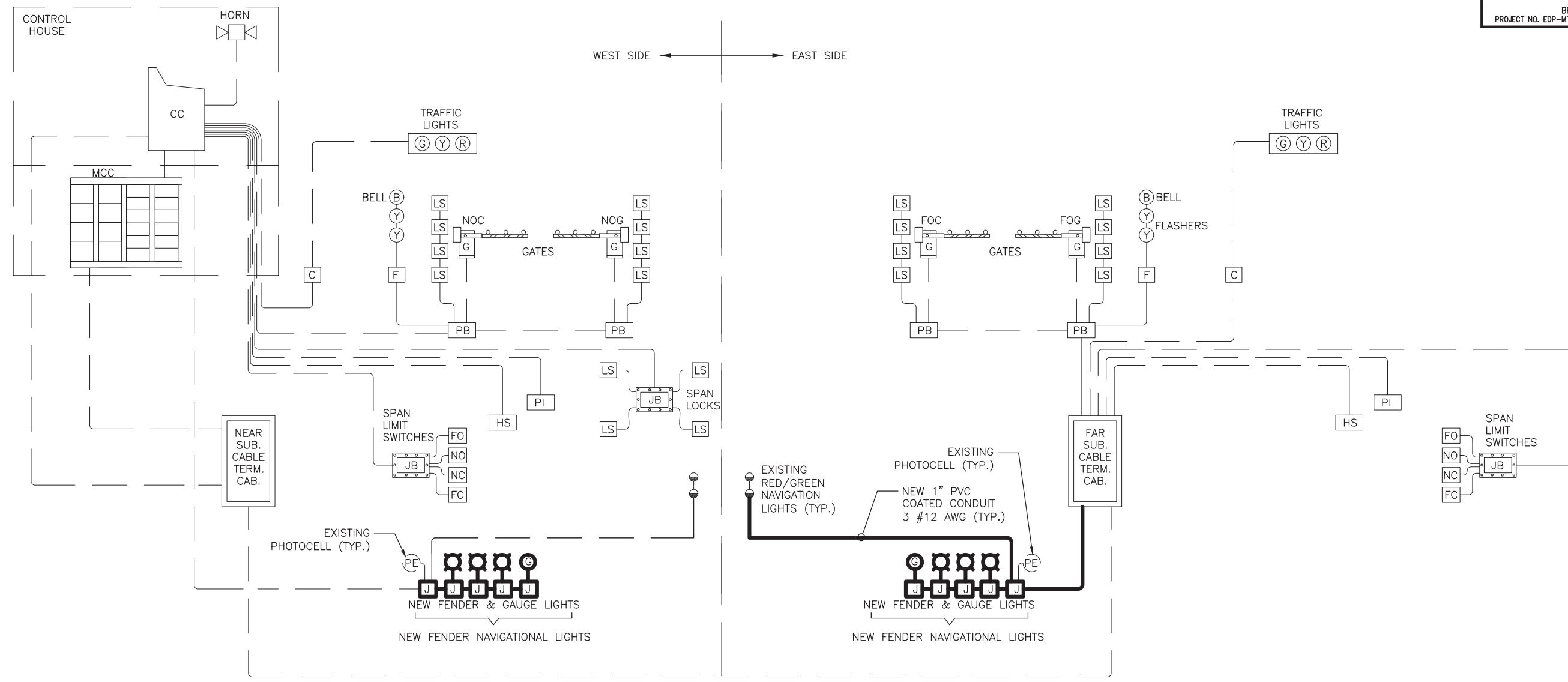

**RER - NATURAL RESOURCES DIVISION  
 PRELIMINARY APPROVAL**  
 NAME Micaela Soldi  
 DATE 04/12/2021

**RER - NATURAL RESOURCES DIVISION  
 FINAL APPROVAL**  
 NAME Ashley Dominguez  
 DATE 12/22/2022

**LEGEND**

- CC CONTROL CONSOLE
- MCC MOTOR CONTROL CENTER
- LS LIMIT SWITCH
- PB EXISTING PULL BOX
- EXISTING CONDUIT
- POSITION INDICATOR
- PI NEW CONDUIT
- J JUNCTION BOX
- EXISTING PHOTOELECTRIC CELL

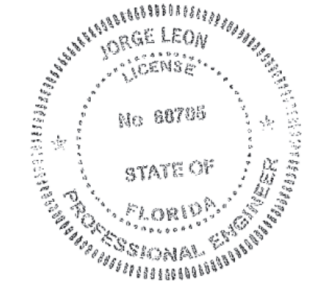

**JL**  
 Digitally signed by J.L. DN: cn=JL, e=jorge.leon@stvinc.com, o=STV inc., CN=JL  
 Date: 2020.12.04 09:37:19 -0500

BRIDGE NO. 874474

I:\Projects\4020712\4020712\_0001\90\_CAD Models and Sheets\14\_Electrical\BE05- Control Riser Diagram East.dwg Jul 15, 2020 - 3:42pm PERERAM

REVISIONS					
DATE	BY	DESCRIPTION	DATE	BY	DESCRIPTION

**STV** INCORPORATED 6303 BLUE LAGOON DR. SUITE 400 | MIAMI FL, 33126 (305)537-4673 FAX: (305)751-5311 JORGE LEON FL. LICENSE # 68705

DESIGNED BY	JL	DATE	06/22/2020	DRAWN BY	MPS	DATE	06/24/2020
CHECKED BY	MPS	DATE	06/30/2020	CHECKED BY	JL	DATE	06/30/2020
SUPERVISED BY:							

**MIAMI-DADE COUNTY** DEPARTMENT OF TRANSPORTATION AND PUBLIC WORKS HIGHWAY DIVISION  
 111 NW 1 ST MIAMI, FLORIDA 33128

BE-05 BRIDGE CONDUIT DIAGRAM EAST VENETIAN

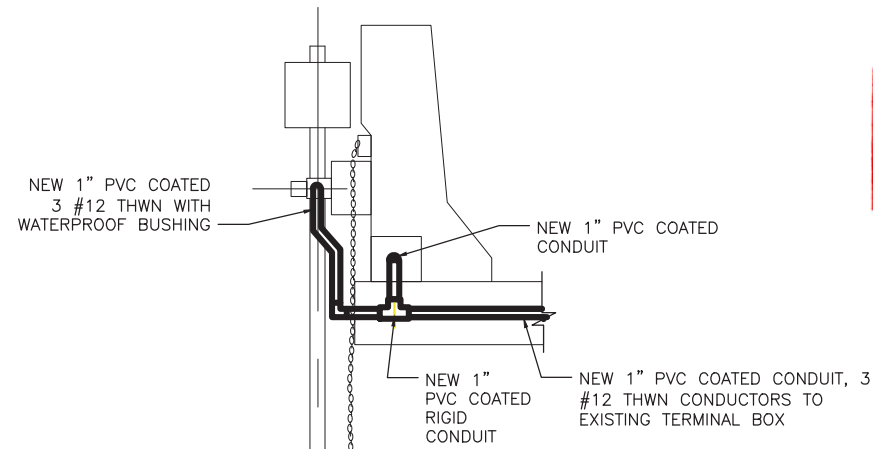

**RER - NATURAL RESOURCES DIVISION  
 PRELIMINARY APPROVAL**  
 NAME Micaela Soldi  
 DATE 04/12/2021

**RER - NATURAL RESOURCES DIVISION  
 FINAL APPROVAL**  
 NAME Ashley Dominguez  
 DATE 12/22/2022

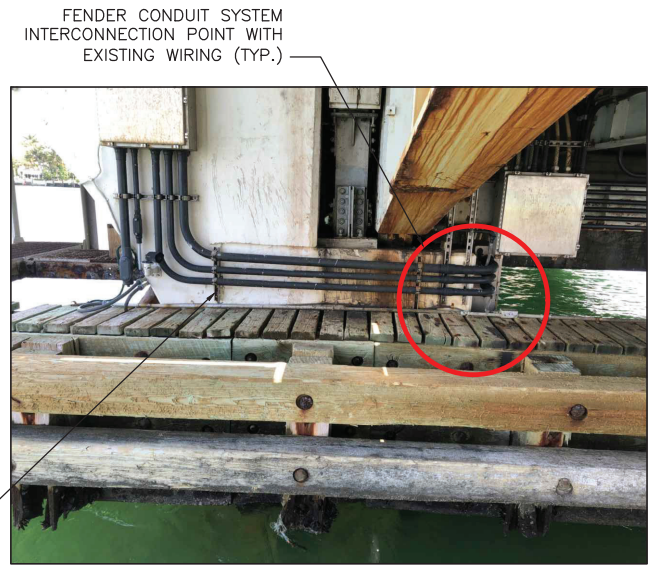

EAST VENETIAN (BRIDGE No. 874474)

EXISTING CENTER CHANNEL MARKET NAVIGATION LIGHT FOR BASCULE BRIDGES  
 N.T.S.

NOTE: THIS CONDUIT DETAIL APPLIES ONLY TO EAST VENETIAN (BRIDGE No. 874474) FAR SIDE

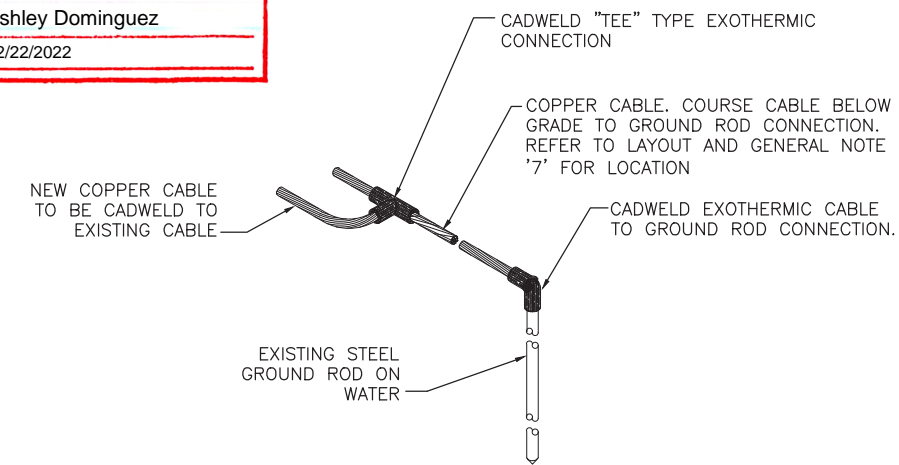
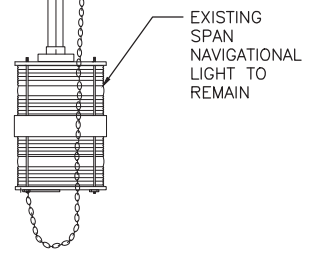

TYPICAL DOWNLOAD TO GROUNDING CONNECTION  
 N.T.S.

NOTE: REFER TO PHOTO BELOW

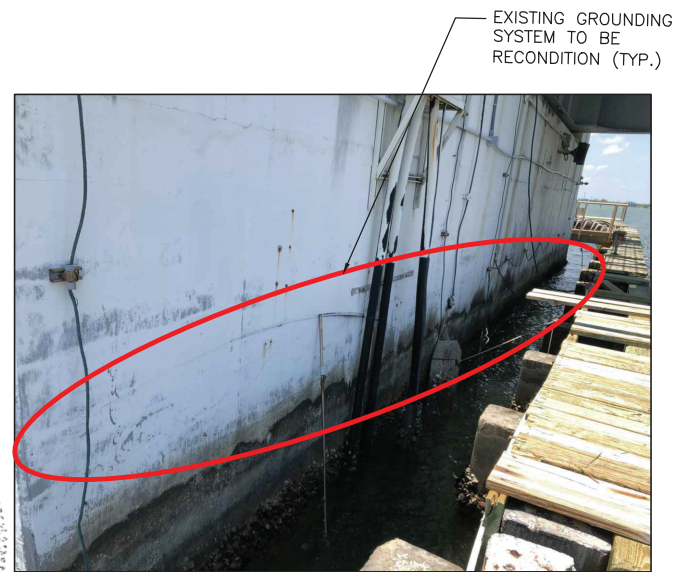

EXISTING J-BOX TO BE REPLACED WITH NEW J-BOX TO FENDER SYSTEM

EXISTING GROUNDING SYSTEM TO BE REPLACED (TYP.)

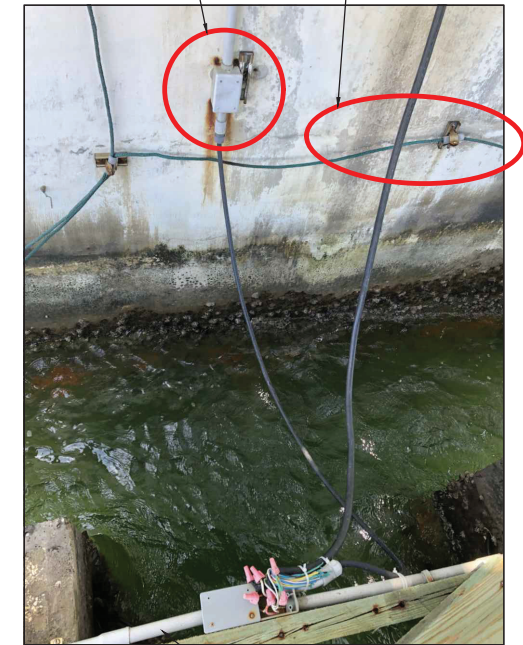

EXISTING FENDER CONDUIT SYSTEM TO BE REPLACED WITH NEW PVC COATED CONDUIT (TYP.)

WEST VENETIAN (BRIDGE No. 874459)

BRIDGE NO. 874459 & 874474

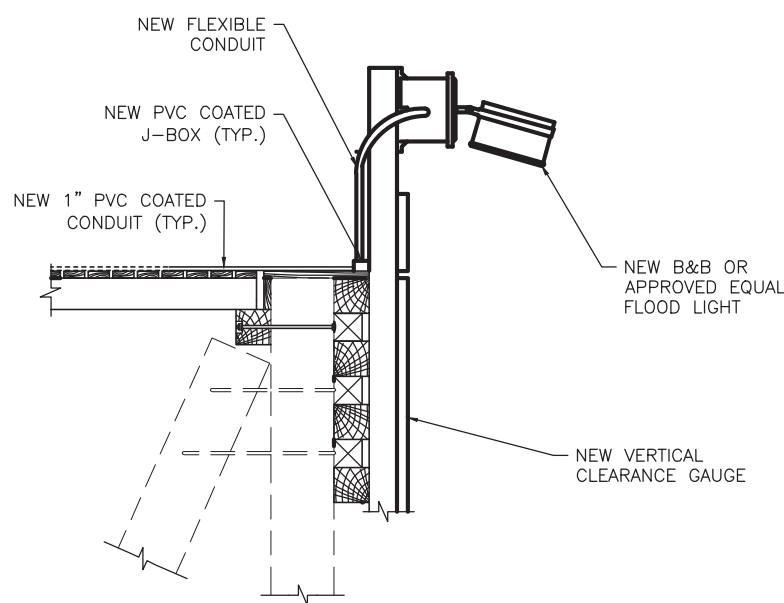

NEW TYPICAL CLEARANCE GAUGE LIGHT DETAIL  
 N.T.S.

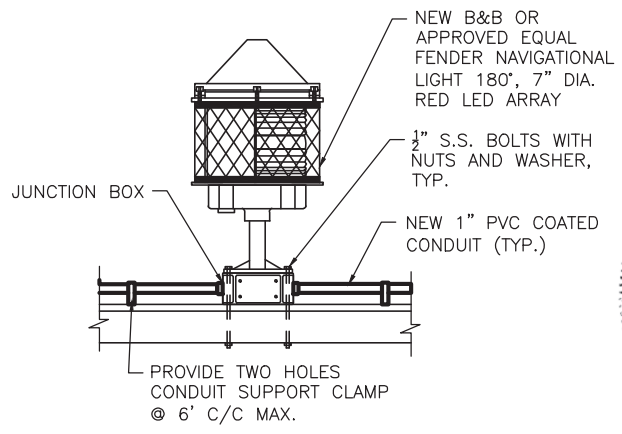

NEW TYPICAL FENDER LIGHT DETAIL  
 N.T.S.

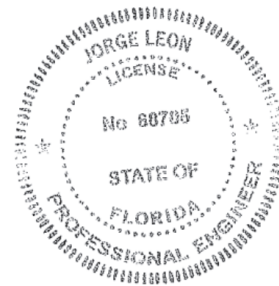

Digitally signed by JL  
 DN: C=US,  
 E=jorge.leon@stvinc.com,  
 O=STV Inc. CA=FL  
 Date: 2020.12.04  
 09:13:38-05'00'

I:\Projects\4020712\4020712\_0001\90\_CAD Models and Sheets\14\_Electrical\BE06- Navigational Lights Details.dwg Jul 17, 2020 - 1:44pm PERERAM

REVISIONS					
DATE	BY	DESCRIPTION	DATE	BY	DESCRIPTION

STV INCORPORATED 6303 BLUE LAGOON DR. SUITE 400   MIAMI FL, 33126 (305)537-4673 FAX: (305)751-5311 JORGE LEON FL. LICENSE # 68705					
DESIGNED BY	JL	DATE	06/22/2020	DRAWN BY	MPS
CHECKED BY	MPS	DATE	06/30/2020	CHECKED BY	JL
SUPERVISED BY		DATE	06/30/2020		

DEPARTMENT OF TRANSPORTATION AND PUBLIC WORKS HIGHWAY DIVISION  
 STEPHEN P. CLARK CENTER  
 111 NW 1 ST  
 MIAMI, FLORIDA 33128

**SFWMD**





# SOUTH FLORIDA WATER MANAGEMENT DISTRICT

---

## MEMORANDUM

**DATE:** November 28, 2022

**TO:** DSL Title & Land Records Section  
[DSL.FAX@DEP.STATE.FL.US](mailto:DSL.FAX@DEP.STATE.FL.US)

**FROM:** Caroline Hanes  
Regulation Division

**SUBJECT: Request for Title Review**

**Application #:** 221102-36461  
**Project Name:** Venetian Causeway Bridge Repairs Bridge 874459 and 84774  
**Location:** Miami-Dade County  
**Applicant:** Gabriel Delgado, PE, Pmp  
**Description:** Transportation  
**Parcel ID:** 0232320111700  
**Acreage:** 5.54

Please review the title of the above referenced property. Please send your response to [epermits@sfwmd.gov](mailto:epermits@sfwmd.gov). Include the following information with the standard title worksheet or indicate if this information is not available.

Determination of state ownership below OHW/MHW



# SOUTH FLORIDA WATER MANAGEMENT DISTRICT

December 2, 2022

*\* Delivered via email*

Gabriel Delgado, PE, Pmp \*  
Miami-dade Dept Of Transportation and Public Works, Engineering, Planning  
701 NW 1st Court  
Suite 1500  
Miami, FL 33136

**Subject: Exemption for Venetian Causeway Bridge Repairs Bridge 874459 and 84774  
Application No. 221102-36461  
Exemption No. 13-108008-P  
Miami-Dade County**

Dear Mr. Delgado:

The South Florida Water Management District (District) reviewed the information submitted for the proposed repairs to the bridge fender system of two Venetian Causeway bridges as depicted and described in Exhibits 1.0, 2.0 and 2.1. The District has determined that the proposed project is exempt from the requirement to obtain an Environmental Resource Permit, pursuant to Section 373.406(6), F.S..

Work will occur over and in the surface waters of Biscayne Bay, but no work will occur on the submerged bottom. This letter includes authorization by a letter of consent for activities over sovereign submerged lands in accordance with section 18-21.005(1)(c)7, F.A.C. and the attached General Conditions for Authorizations for Use of Sovereign Submerged Lands.

Activities that qualify for this exemption must be conducted and operated using appropriate best management practices and in a manner which does not cause or contribute to a water quality violation. Pursuant to Chapters 62-302 or 62-4, Florida Administrative Code.

This letter does not relieve you from the responsibility of obtaining other permits (federal, state or local) which may be required for the project.

The determination that this project qualifies as an exempt activity may be revoked if the installation is substantially modified, if the basis of the exemption is determined to be materially incorrect, or if the installation results in violation to state water quality standards. Any changes made in the construction plans or location of the project may necessitate a permit from the District. Therefore you are advised to contact the District before beginning any work in wetlands which is not specifically described in the submittal.

The notice of determination that the project qualifies as an exempt activity constitutes final agency action by the District unless a petition for administrative hearing is filed. Upon timely filing of a petition, this Notice will not be effective until further Order of the District. If you have any questions concerning this matter, please contact Caroline Hanes, Environmental Analyst Senior at (561) 682-6856 or [chanes@sfwmd.gov](mailto:chanes@sfwmd.gov), and Joe Marquez, at (561) 682-6738 or [jmarquez@sfwmd.gov](mailto:jmarquez@sfwmd.gov).

Sincerely,

A handwritten signature in blue ink that reads "Jesse Markle". The signature is stylized with a large, sweeping initial "J" and a long, horizontal stroke for the "M".

Jesse Markle, P.E.  
Bureau Chief, Environmental Resource Bureau

c: Craig Kruempel, Ghd Inc \*

**General Conditions for Authorizations for Use of Sovereign Submerged Lands, Rule  
18-21.004(7), F.A.C.**

All authorizations granted by rule or in writing under Rule 18-21.005, F.A.C., except those for aquaculture activities and geophysical testing, shall be subject to the general conditions as set forth in paragraphs (a) through (i) below. The general conditions shall be part of all authorizations under this chapter, shall be binding upon the grantee, and shall be enforceable under Chapter 253 or Chapter 258, Part II, F.S.

(a) Authorizations are valid only for the specified activity or use. Any unauthorized deviation from the specified activity or use and the conditions for undertaking that activity or use shall constitute a violation. Violation of the authorization shall result in suspension or revocation of the grantee's use of the sovereignty submerged land unless cured to the satisfaction of the Board.

(b) Authorizations convey no title to sovereignty submerged land or water column, nor do they constitute recognition or acknowledgment of any other person's title to such land or water.

(c) Authorizations may be modified, suspended or revoked in accordance with their terms or the remedies provided in Sections 253.04 and 258.46, F.S., or Chapter 18-14, F.A.C.

(d) Structures or activities shall be constructed and used to avoid or minimize adverse impacts to sovereignty submerged lands and resources.

(e) Construction, use, or operation of the structure or activity shall not adversely affect any species which is endangered, threatened or of special concern, as listed in Rules 68A-27.003, 68A-27.004, and 68A-27.005, F.A.C.

(f) Structures or activities shall not unreasonably interfere with riparian rights. When a court of competent jurisdiction determines that riparian rights have been unlawfully affected, the structure or activity shall be modified in accordance with the court's decision.

(g) Structures or activities shall not create a navigational hazard.

(h) Structures shall be maintained in a functional condition and shall be repaired or removed if they become dilapidated to such an extent that they are no longer functional. This shall not be construed to prohibit the repair or replacement subject to the provisions of Rule 18-21.005, F.A.C., within one year, of a structure damaged in a discrete event such as a storm, flood, accident, or fire.

(i) Structures or activities shall be constructed, operated, and maintained solely for water dependent purposes, or for non-water dependent activities authorized under paragraph 18-21.004 (1)(g), F.A.C., or any other applicable law.

## **Exhibits**

The following exhibits to this permit are incorporated by reference. The exhibits can be viewed by clicking on the links below or by visiting the District's ePermitting website (<http://my.sfwmd.gov/ePermitting>) and searching under this application number 221102-36461.

[Exhibit No. 1.0 Location Map](#)

[Exhibit No. 2.0 Plans](#)

[Exhibit No. 2.1 Methodology](#)

## **NOTICE OF RIGHTS**

As required by Chapter 120, Florida Statutes, the following provides notice of the opportunities which may be available for administrative hearing pursuant to Sections 120.569 and 120.57, Florida Statutes, or judicial review pursuant to Section 120.68, Florida Statutes, when the substantial interests of a party are determined by an agency. Please note that this Notice of Rights is not intended to provide legal advice. Some of the legal proceedings detailed below may not be applicable or appropriate for your situation. You may wish to consult an attorney regarding your legal rights.

### **RIGHT TO REQUEST ADMINISTRATIVE HEARING**

A person whose substantial interests are or may be affected by the South Florida Water Management District's (District) action has the right to request an administrative hearing on that action pursuant to Sections 120.569 and 120.57, Florida Statutes. Persons seeking a hearing on a District decision which affects or may affect their substantial interests shall file a petition for hearing in accordance with the filing instructions set forth herein within 21 days of receipt of written notice of the decision unless one of the following shorter time periods apply: (1) within 14 days of the notice of consolidated intent to grant or deny concurrently reviewed applications for environmental resource permits and use of sovereign submerged lands pursuant to Section 373.427, Florida Statutes; or (2) within 14 days of service of an Administrative Order pursuant to Section 373.119(1), Florida Statutes. "Receipt of written notice of agency decision" means receipt of written notice through mail, electronic mail, posting, or publication that the District has taken or intends to take final agency action. Any person who receives written notice of a District decision and fails to file a written request for hearing within the timeframe described above waives the right to request a hearing on that decision.

If the District takes final agency action that materially differs from the noticed intended agency decision, persons who may be substantially affected shall, unless otherwise provided by law, have an additional point of entry pursuant to Rule 28-106.111, Florida Administrative Code.

Any person to whom an emergency order is directed pursuant to Section 373.119(2), Florida Statutes, shall comply therewith immediately, but on petition to the board shall be afforded a hearing as soon as possible.

A person may file a request for an extension of time for filing a petition. The District may grant the request for good cause. Requests for extension of time must be filed with the District prior to the deadline for filing a petition for hearing. Such requests for extension shall contain a certificate that the moving party has consulted with all other parties concerning the extension and whether the District and any other parties agree to or oppose the extension. A timely request for an extension of time shall toll the running of the time period for filing a petition until the request is acted upon.

### **FILING INSTRUCTIONS**

A petition for administrative hearing must be filed with the Office of the District Clerk. Filings with the Office of the District Clerk may be made by mail, hand-delivery, or e-mail. Filings by facsimile will not be accepted. A petition for administrative hearing or other document is deemed filed upon receipt during normal business hours by the Office of the District Clerk at the District's headquarters in West Palm Beach, Florida. The District's normal business hours are 8:00 a.m. – 5:00 p.m., excluding weekends and District holidays. Any document received by the Office of the District Clerk after 5:00 p.m. shall be deemed filed as of 8:00 a.m. on the next regular business day.

Additional filing instructions are as follows:

- Filings by mail must be addressed to the Office of the District Clerk, 3301 Gun Club Road, West Palm Beach, Florida 33406.
- Filings by hand-delivery must be delivered to the Office of the District Clerk. Delivery of a

petition to the District's security desk does not constitute filing. It will be necessary to request that the District's security officer contact the Office of the District Clerk. An employee of the District's Clerk's office will receive and process the petition.

- Filings by e-mail must be transmitted to the Office of the District Clerk at [clerk@sfwmd.gov](mailto:clerk@sfwmd.gov). The filing date for a document transmitted by electronic mail shall be the date the Office of the District Clerk receives the complete document.

### **INITIATION OF ADMINISTRATIVE HEARING**

Pursuant to Sections 120.54(5)(b)4. and 120.569(2)(c), Florida Statutes, and Rules 28-106.201 and 28-106.301, Florida Administrative Code, initiation of an administrative hearing shall be made by written petition to the District in legible form and on 8 1/2 by 11 inch white paper. All petitions shall contain:

1. Identification of the action being contested, including the permit number, application number, District file number or any other District identification number, if known.
2. The name, address, any email address, any facsimile number, and telephone number of the petitioner, petitioner's attorney or qualified representative, if any.
3. An explanation of how the petitioner's substantial interests will be affected by the agency determination.
4. A statement of when and how the petitioner received notice of the District's decision.
5. A statement of all disputed issues of material fact. If there are none, the petition must so indicate.
6. A concise statement of the ultimate facts alleged, including the specific facts the petitioner contends warrant reversal or modification of the District's proposed action.
7. A statement of the specific rules or statutes the petitioner contends require reversal or modification of the District's proposed action.
8. If disputed issues of material fact exist, the statement must also include an explanation of how the alleged facts relate to the specific rules or statutes.
9. A statement of the relief sought by the petitioner, stating precisely the action the petitioner wishes the District to take with respect to the District's proposed action.

### **MEDIATION**

The procedures for pursuing mediation are set forth in Section 120.573, Florida Statutes, and Rules 28-106.111 and 28-106.401–.405, Florida Administrative Code. The District is not proposing mediation for this agency action under Section 120.573, Florida Statutes, at this time.

### **RIGHT TO SEEK JUDICIAL REVIEW**

Pursuant to Section 120.68, Florida Statutes, and in accordance with Florida Rule of Appellate Procedure 9.110, a party who is adversely affected by final District action may seek judicial review of the District's final decision by filing a notice of appeal with the Office of the District Clerk in accordance with the filing instructions set forth herein within 30 days of rendition of the order to be reviewed, and by filing a copy of the notice with the appropriate district court of appeals via the Florida Courts E-Filing Portal.

**From:** [Hanes, Caroline](#)  
**To:** [Delgado, Gabriel \(DTPW\)](#)  
**Cc:** [Oscar Cruz](#); [Fisher, Ryan \(DTPW\)](#); [Precht, Lindsey \(RER\)](#); [Conmy, Barbara](#); [Meyer, Jeffrey L](#); [Drakes, Gina \(MDPR\)](#)  
**Subject:** RE: Submerged Lands Authorization request for: Venetian Causeway Hurricane Irma repairs  
**Date:** Monday, February 7, 2022 12:10:13 PM  
**Attachments:** [image004.png](#)

---

EMAIL RECEIVED FROM EXTERNAL SOURCE

Hi Gabriel,

For the proprietary authorization, the activities in the emails below can be approved by a Letter of Consent, section 18-21.005(1)(c)7, F.A.C. – repair or replacement of a functional structure or activity... in the same dimensions and for the same type of use. The County can apply for a de minimis exemptions under section 373.406(6), F.S. for the regulatory approval and the proprietary approval under the above citation.

Please let me know if you have further questions.

Thank you,

*Caroline Hanes, PWS*  
*Environmental Analyst Lead*  
*Regulation Division*  
*Environmental Resource Permitting Bureau*  
*South Florida Water Management District*  
*3301 Gun Club Road, MSC 9210*  
*West Palm Beach, FL 33406*  
*Phone: 561-682-6856*  
*Fax: 561-682-6896*  
[chanes@sfwmd.gov](mailto:chanes@sfwmd.gov)

logoepermitting2



**NOTE:**

While the District supports that it is commonplace and convenient to collaborate via email during the pre-application/application process, Permit Applications and Responses to a Request for Additional Information (RAI) submitted via email are not an official submittal (Section 4.4 of Environmental Resource Permit Applicant's Handbook Volume I). For timely and efficient processing of permit applications and RAI responses, please submit online using ePermitting (link above).

---

**From:** Delgado, Gabriel (DTPW) <Gabriel.Delgado@miamidade.gov>

**Sent:** Monday, February 7, 2022 10:45 AM



**To:** Hanes, Caroline <chanes@sfwmd.gov>

**Cc:** Oscar Cruz <ocruz@chromeeng.com>; Fisher, Ryan (DTPW) <Ryan.Fisher@miamidade.gov>; Precht, Lindsey (RER) <Lindsey.Precht@miamidade.gov>; Conmy, Barbara <bconmy@sfwmd.gov>; Meyer, Jeffrey L <Jeffrey.L.Meyer@FloridaDEP.gov>; Drakes, Gina (MDPR) <Gina.Drakes@miamidade.gov>

**Subject:** Re: Submerged Lands Authorization request for: Venetian Causeway Hurricane Irma repairs

**Importance:** High

[Please remember, this is an external email]

Good morning Caroline,

Just following up on this. We are receiving requests for updated project schedules and information from FEMA, however, I can't move this project any further without a resolution on this issue with the Submerged Lands.

Without the authorization, we cannot finalize our permitting with RER. When possible, I request assistance in resolving this issue, we simply cannot afford to continue delaying the project for these needed repairs.

Thank you,

**Gabriel Delgado**, P.E.

Project Manager, Highway Bridge Engineering

Miami-Dade Department of Transportation and Public Works

Engineering, Planning and Development | Overtown Transit Village

701 N.W. 1<sup>st</sup> Court, Suite 1500, Miami, FL 33136

Telephone: (786) 469-5371 | Fax: (786) 469-5572

[www.miamidade.gov/transit](http://www.miamidade.gov/transit)

---

**From:** Delgado, Gabriel (DTPW) <[Gabriel.Delgado@miamidade.gov](mailto:Gabriel.Delgado@miamidade.gov)>

**Sent:** Monday, January 10, 2022 2:06 PM

**To:** Hanes, Caroline <[chanes@sfwmd.gov](mailto:chanes@sfwmd.gov)>

**Cc:** Oscar Cruz <[ocruz@chromeeng.com](mailto:ocruz@chromeeng.com)>; Fisher, Ryan (DTPW) <[Ryan.Fisher@miamidade.gov](mailto:Ryan.Fisher@miamidade.gov)>

**Subject:** Re: Submerged Lands Authorization request for: Venetian Causeway Hurricane Irma repairs

Good afternoon Caroline,

Thank you for providing the information and coordinating the Title Determination with DEP.

Although the findings show that parts of the bottom are deeded historically, are there any exemptions that allow for over-water work that won't affect any of the submerged lands?

At this point, what would be our next step? Since this is a FEMA-reimbursement project, we have been trying to expedite where we can in order to finalize permitting and advertise for Construction. Any help on your part to expedite or finalize this process would be most appreciated.

Thank you,

**Gabriel Delgado**, P.E.

Project Manager, Highway Bridge Engineering

Miami-Dade Department of Transportation and Public Works

Engineering, Planning and Development | Overtown Transit Village

701 N.W. 1<sup>st</sup> Court, Suite 1500, Miami, FL 33136

Telephone: (786) 469-5371 | Fax: (786) 469-5572

[www.miamidade.gov/transit](http://www.miamidade.gov/transit)

---

**From:** Hanes, Caroline <[chanes@sfwmd.gov](mailto:chanes@sfwmd.gov)>

**Sent:** Wednesday, January 5, 2022 11:40 AM

**To:** Delgado, Gabriel (DTPW) <[Gabriel.Delgado@miamidade.gov](mailto:Gabriel.Delgado@miamidade.gov)>

**Cc:** Oscar Cruz <[ocruz@chromeeng.com](mailto:ocruz@chromeeng.com)>; Fisher, Ryan (DTPW) <[Ryan.Fisher@miamidade.gov](mailto:Ryan.Fisher@miamidade.gov)>

**Subject:** RE: Submerged Lands Authorization request for: Venetian Causeway Hurricane Irma repairs

**EMAIL RECEIVED FROM EXTERNAL SOURCE**

Hi Gabriel, and Happy New Year to you, too!

Yes, DEP provided a title determination. It appears that some of the bottom is deeded and some may be within areas subject to sovereign submerged lands (SSL) leases and/or easements. I haven't had a chance to look at all the supporting documents. It is complicated.

It has been a while since discussing the project details with you. If no work will be done in the water that may make the approval process much easier.

The determination is attached. You may be able to register with the state lands database and log in to access the documents if you want to try that. Use the link in the attached email. Let me know if you have further questions.

Thank you,

*Caroline Hanes, PWS*  
*Environmental Analyst Lead*  
*Regulation Division*  
*Environmental Resource Permitting Bureau*  
*South Florida Water Management District*  
*3301 Gun Club Road, MSC 9210*  
*West Palm Beach, FL 33406*  
*Phone: 561-682-6856*  
*Fax: 561-682-6896*  
[chanes@sfwmd.gov](mailto:chanes@sfwmd.gov)

logoepermitting2



**NOTE:**

While the District supports that it is commonplace and convenient to collaborate via email during the pre-application/application process, Permit Applications and Responses to a Request for Additional Information (RAI) submitted via email are not an official submittal (Section 4.4 of Environmental Resource Permit Applicant's Handbook Volume I). For timely and efficient processing of permit applications and RAI responses, please submit online using ePermitting (link above).

---

**From:** Delgado, Gabriel (DTPW) <[Gabriel.Delgado@miamidade.gov](mailto:Gabriel.Delgado@miamidade.gov)>

**Sent:** Wednesday, January 5, 2022 8:39 AM

**To:** Hanes, Caroline <[chanes@sfwmd.gov](mailto:chanes@sfwmd.gov)>

**Cc:** Oscar Cruz <[ocruz@chromeeng.com](mailto:ocruz@chromeeng.com)>; Fisher, Ryan (DTPW) <[Ryan.Fisher@miamidade.gov](mailto:Ryan.Fisher@miamidade.gov)>

**Subject:** Re: Submerged Lands Authorization request for: Venetian Causeway Hurricane Irma repairs

[\[Please remember, this is an external email\]](#)

Good morning Caroline,

I hope you and your family had a happy new year!

Just wanted to follow up - Has FDEP returned with an opinion on the Submerged Lands for this project?

Thank you,

**Gabriel Delgado**, P.E.

Project Manager, Highway Bridge Engineering

Miami-Dade Department of Transportation and Public Works

Engineering, Planning and Development | Overtown Transit Village

701 N.W. 1<sup>st</sup> Court, Suite 1500, Miami, FL 33136

Telephone: (786) 469-5371 | Fax: (786) 469-5572

[www.miamidade.gov/transit](http://www.miamidade.gov/transit)

---

**From:** Fisher, Ryan (DTPW) <[Ryan.Fisher@miamidade.gov](mailto:Ryan.Fisher@miamidade.gov)>

**Sent:** Tuesday, December 21, 2021 10:07 AM

**To:** Delgado, Gabriel (DTPW) <[Gabriel.Delgado@miamidade.gov](mailto:Gabriel.Delgado@miamidade.gov)>; Hanes, Caroline <[chanes@sfwmd.gov](mailto:chanes@sfwmd.gov)>

**Cc:** Oscar Cruz <[ocruz@chromeeng.com](mailto:ocruz@chromeeng.com)>

**Subject:** RE: Submerged Lands Authorization request for: Venetian Causeway Hurricane Irma repairs

Good Morning Caroline,

Just to be clear, this is a maintenance project to repair wooden fender system damaged by hurricane Irma, there should be no long term shading of any area and the repairs should take a week or so of the actual fenders themselves. This does not include any disturbance of the sea floor or driving of any new pile.

This process of getting this authorization for maintenance repairs is delaying the federal project of making these repairs and the use of the federal funds.

Please do what you can to get us this authorization ASAP as we have been ready to go to construction and have had to report delays to FEMA for many months.

Regards,

**Ryan Fisher**, P.E.

Manager, Highway Bridge Engineering

Miami-Dade Department of Transportation and Public Works

Engineering, Planning and Development | Overtown Transit Village



## **SOUTH FLORIDA WATER MANAGEMENT DISTRICT RIGHT OF WAY SECTION**

### **REQUIREMENTS TO ADDRESS MEANS AND METHODS OF CONSTRUCTION; REQUIREMENT TO OBTAIN A SEPARATE ROW PERMIT FOR TEMPORARY ACCESS**

---

Right of Way Occupancy Permits (ROW Permits) for bridges and other major projects are often approved in “concept only” because the plans only depict the completed project proposed in the right of way. During application review, applicants are often unable to provide the “means and methods” of construction because no contractor has been chosen and there are no specific details as to how the project will be built by any given contractor.

For this reason, ROW Permits often require an applicant’s chosen contractor to apply for and obtain its own separate ROW Permit that addresses the specific details for construction. When a ROW Permit includes a special condition advising that the project is approved in “concept only”, this document will be attached to and incorporated into the ROW Permit by reference. No work within the right of way may commence until the contractor obtains its own separate ROW Permit.

Project managers or agents of the permittee are strongly urged to include this document along with a copy of the Main Project ROW Permit in the bid package for the project. All questions from potential bidders regarding the ROW Permit and District requirements must be submitted to the District through the permittee so that all bidders can have access to the same District response.

#### **IN GENERAL.**

All contractors and subcontractors who seek or are awarded a contract to construct a bridge or other major project in the District’s right of way which is approved in “Concept Only” shall comply with the following requirements. Approved in “Concept Only” means that no means or methods for the construction of the proposed project have been reviewed and approved by the District. A special condition of the ROW Permit will identify whether a project is approved in “Concept Only” and will incorporate the requirements set forth in this attachment by reference.

#### **FILING AN APPLICATION FOR THE ROW PERMIT TO ALLOW TEMPORARY ACCESS.**

Contractors who will perform the work authorized by a ROW Permit approved in Concept Only are required to obtain a ROW Permit for temporary access to enter upon the right of way to perform the work (“Temporary Access Permit”). The application must be filed online at

[www.sfwmd.gov/rowpermits](http://www.sfwmd.gov/rowpermits). No work, staging, storage of materials, or use of the right of way may proceed without first having obtained the required ROW Permit.

**COMPLIANCE WITH ROW PERMIT CONDITIONS FOR THE PROJECT APPROVED IN “CONCEPT ONLY” (“MAIN PROJECT PERMIT”).**

Compliance with all special, general, and standard limiting conditions of the Main Project Permit shall be required. Contractors should note that certain stages of work may not proceed until specific deliverable are provided to the District (e.g., certified cross-sectional surveys following dredging, as-builts, etc.) or certain work is completed (e.g., dredging to the required cross-section must be completed before pile driving may proceed). Contractors should carefully review the Main Project Permit to identify required intermittent inspections and permittee obligations and accommodate them in development of the project schedule.

**COMPLIANCE WITH ROW PERMIT CONDITIONS FOR THE MEANS AND METHODS OF CONSTRUCTION (“TEMPORARY ACCESS PERMIT”).**

Compliance with all special, general, and standard limiting conditions of the Temporary Access Permit shall be required. Applications for the Temporary Access Permit will be required to provide written narrative, plans, and supporting documents to address the following requirements:

- **Plans/Aerials.**

Plans/aerials must show access to the work area from a public roadway, proposed equipment and material staging areas, vehicle parking areas, proposed temporary utility services, construction trailers, turbidity barriers, and other temporary uses that may be proposed in the District’s right of way. Plans must be drawn to scale and clearly delineate the top of bank of the canal and District right of way lines. Please be advised that no parking, storage, or other uses will be authorized within 40 feet of the top of bank unless expressly authorized by the District, and no use of cofferdams or other devices/activities that adversely impact canal flow will not be authorized. District access through the right of way must be maintained as directed by the District in its review and approval of the plans. The manner and location of approved uses in the right of way is at the sole discretion of the District.

- **Means and Methods of Construction.**

Contractors are required to submit a narrative outlining the general means and methods of construction with emphasis on activities that may adversely impact operations and maintenance of the District’s flood control system and rights of way.

- **Barge Management Plan.**

Contractors who propose to use a barge to construct an authorized work in the District’s right of way are required to submit a Barge Management Plan. Please contact District staff at [rowpermits@sfwmd.gov](mailto:rowpermits@sfwmd.gov) to obtain the requirements for a Barge Management Plan.

- **Access over District Structures and Bridges.**  
Contractors who propose access of vehicles and equipment over District bridges and structures are required to provide a structural analysis and perform documentation to determine if District facilities can accommodate the type, weight, length, and intensity of use of vehicles and equipment. Please contact District staff at [rowpermits@sfwmd.gov](mailto:rowpermits@sfwmd.gov) to obtain the requirements for authorization for access over District structures and bridges.
- **Emergency Management/Environmental Impact/Containment Plan.**  
Contractors must submit an emergency management plan to describe how the canal and right of way will be secured and/or vacated if directed by the District in advance of a storm or flooding event. In addition, contractors must submit a plan to address environmental clean-up and containment of hazardous material if a vehicle or equipment should fall into a canal or spill on to the right of way. Contractors are required to have equipment and/or supplies available at the work site at all times.
- **Vehicle List.**  
The application is required to include a vehicle and equipment list, including types, axles, weight, length, and width. In addition, the list must include the number of anticipated trips per day per vehicle.
- **Construction Trailers; Storage of Materials and Equipment.**  
Requests for construction trailers must comply with the District's requirements set forth on pages 134 and 135 of the Criteria Manual for Use of Works and Lands of the District. The criteria manual may be accessed at [www.sfwmd.gov/rowpermits](http://www.sfwmd.gov/rowpermits).
- **Temporary Utility Service.**  
Work requiring temporary utility service may require a separate ROW Permit (e.g., temporary pole, temporary aerial line to construction trailer, etc.). Please consult with District staff to determine if a separate application is required.

## **OTHER CONSIDERATIONS.**

### **PRE-CONSTRUCTION MEETING.**

A pre-construction meeting for both the Main Project Permit and the Temporary Access Permit will be held at the same time and is required prior to any work, set-up, use, access, or delivery of materials upon or to the right of way. Permittee and its chosen contractors/subcontractors should attend the pre-construction meeting which will be coordinated with the District field representative assigned to both ROW Permits.

### **FINANCIAL ASSURANCE.**

Contractors seeking a Temporary Access Permit will be required to post a financial assurance in a form and amount required by the District. The amount of the financial assurance will be based upon the length of the proposed travel route, intensity of vehicle and equipment use, and risk of damage to and value of District structures and bridges that must be crossed to access the work location. The financial assurance must be posted prior to issuance of the Row Permit.

**INSURANCE.**

Contractors seeking a Temporary Access Permit will be required to provide evidence of insurance to the satisfaction of the District. The certificate must include general liability coverage of \$1,000,000 per occurrence (minimum) and name the South Florida Water Management District as additional insured. A copy of the applicable endorsement from the insurer is also required. The expiration date for the certificate should be later than the completion date of the work or as late as possible since the expiration date of the Temporary Access Permit will coincide with the insurance expiration date.

**KEY PERMIT/DISTRICT KEY TO OPEN DISTRICT GATES.**

Contractors seeking a Temporary Access Permit will be required to obtain a separate key permit from the District if access to the proposed work site requires entry through a District gate. A key permit allowing issuance of a District gate key can only be approved following issuance of the Temporary Access Permit. A deposit for the key is required and conditions related to the opening and securing of the District gate(s) will be included in the Temporary Access Permit. The key deposit will be refunded upon return of the key to the District after work is completed. The gate key must be returned to the District prior to the release of any required financial assurance.

**THIRD-PARTY INSPECTORS.**

For certain projects, the District requires permittee to provide the services of a third-party inspector for the benefit of the District. The third-party inspector is retained by permittee and/or permittee's contractor and provides reports, documentation, and reports as prescribed and in a manner directed by the District field representative assigned to the Main Project Permit. Contractors are encouraged to coordinate with permittee regarding the hiring of the third-party inspector. The third-party inspector is required to attend the pre-construction meeting for the ROW Permits.

**MATERIAL CHANGES (e.g., Changes to Approved Construction Materials).**

Contractors should anticipate that the work authorized by a ROW Permit must be completed in accordance with the approved plans and District specifications, when required. The District does not routinely approve requests for material changes, which, if authorized by the District, is at the District's sole discretion. The District shall not be liable for any losses or delays caused by the denial of requests for material changes.

**QUESTIONS?**

District Right of Way staff is available to assist with questions you may have. Please direct your questions to [rowpermits@sfwmd.gov](mailto:rowpermits@sfwmd.gov).

Effective 02/21/2022



## **SECTION 5: SUPPLEMENTARY CONDITIONS**

## SUPPLEMENTARY CONDITIONS

**SUPPLEMENTARY CONDITIONS**  
**TABLE OF CONTENTS**

**1. SUPPLEMENTARY CONDITIONS**

---

1.01	MISCELLANEOUS CONSTRUCTION CONTRACT (7360 PLAN).....	1
1.02	APPLICABLE WAGE RATES.....	1
1.03	CONTINGENCY ALLOWANCE FOR TIME.....	1
1.04	WEATHER DELAYS .....	2
1.05	ADDITIONAL FUNDING SOURCE PROVISIONS .....	3
1.06	LAWS & REGULATIONS .....	4
1.07	CONTRACTOR RESPONSIBILITIES .....	5
1.08	TITLE VI ASSURANCE – DOT 1050.2A, APPENDIX A AND APPENDIX E .....	8
1.09	ADDITIONAL SBE-CONST CONTRACT MEASURE REQUIREMENTS .....	10
1.10	DISADVANTAGED BUSSINESS ENTERPRISE PROGRAM .....	10
1.11	PROMPT PAYMENTS AND RETAINAGE: .....	13
1.12	MATERIALS ACCEPTANCE AND CERTIFICATION SYSTEM (MAC).....	14
1.13	ON-THE-JOB TRAINING REQUIREMENTS.....	14
1.14	COMMUNITY WORKFORCE PROGRAM .....	19
1.15	CLEARINGHOUSE FOR POSTING NOTICE OF JOB OPPORTUNITIES .....	19
1.16	RESIDENTS FIRST TRAINING AND EMPLOYMENT PROGRAM COMPLIANCE .....	19
1.17	EMPLOY MIAMI-DADE PROGRAM.....	19
1.18	ACCEPTANCE TESTS .....	19
1.19	CHANGE ORDER PROCEDURES AND BASIS FOR PAYMENT .....	20
1.20	MIAMI-DADE COUNTY’S USER ACCESS PROGRAM (UAP).....	20
1.21	PUBLIC RECORDS AND CONTRACTS FOR SERVICES PERFORMED ON BEHALF OF MIAMI-DADE COUNTY. ....	21
1.22	NONDISCRIMINATION.....	21
1.23	CONTRACTOR DUE DILIGENCE AFFIDAVIT .....	22
1.24	CLAIMS .....	22
1.25	DISPUTES.....	26
1.26	EXTRA WORK .....	27
1.27	WARRANTY OF CONSTRUCTION .....	31
1.28	CONFLICT OF INTEREST .....	32

## APPENDIX TO THE SUPPLEMENTARY CONDITIONS

Appendix A: Davis Bacon Wages

Appendix B: FHWA-1273 Required Contract Provisions for Federal Aid Construction Contracts

Appendix C: Executive Order 11246 Equal Employment Opportunity

Appendix D: (OSHA) Form 300, 300A and 301

Appendix E Project Worksheet

## 1. SUPPLEMENTARY CONDITIONS

---

### 1.01 MISCELLANEOUS CONSTRUCTION CONTRACT (7360 PLAN)

- A. These Supplementary Conditions amend or supplement the Miscellaneous Construction Contract (MCC) CICC 7360-0/08, the MCC 7360 Plan, and other provisions of the Contract Documents as indicated below. All provisions that are not so amended or supplemented remain in full force and effect. All requirements of the Contract Documents, or portions thereof, which are not specifically modified, deleted, or superseded hereby, remain in full effect. The MCC Contract and Plan may also be supplemented elsewhere in the Contract Documents by provisions located in, but not necessarily limited to, Division 1 (General Requirements) of the Contract Specifications.

### 1.02 APPLICABLE WAGE RATES

- A. Amend Paragraph 2.17 of the CICC 7360-0/08 Miscellaneous Construction Contract by adding the following:
1. The overall per hour rate shall be the rate of wages (including fringes) to be paid under the requirements of the Davis-Bacon Act as determined by the U.S. Department of Labor under the Davis-Bacon Act on project contracts. The listed Davis Bacon Wage Rate listed below is applicable to this contract, and/or any modification up to ten (10) days prior to the opening of the bids.
  2. The applicable U.S. Department of Labor (DOL) Davis Bacon Wage Determination, Construction Type: Heavy, is FL20230125 01/20/2023, and is provided as Appendix A to these Supplementary Conditions, subject to modification pursuant to 29 CFR 1.6. A copy of the Davis-Bacon Wage Determination for the work can also be obtained from the DOL website at <http://www.wdol.gov/dba.aspx>. Contractor must comply with the minimum rates for wages for laborers and mechanics as determined by the Secretary of Labor in accordance with the provisions of the Davis-Bacon and Related Acts. For the submittal of additional Davis Bacon wage classification requests please refer to the Florida Department of Transportation "Classification Request Manager" at the following link: <http://www.dot.state.fl.us/construction/Wage.shtm>.
  3. Certified payrolls submitted must contain all the information required to be maintained under 29 CFR 5.5 (a) (3) (i) except that full social security numbers and home addresses must not be included. An individual identifying number for each employee (e.g. last four digits of social security number) may be used. Unless a specific form is required by the Contract Documents pursuant to funding source requirements, a general form to submit certified weekly payrolls for contracts subject to the Davis-Bacon and related Acts may be obtained at the DOL website at <http://www.dol.gov/whd/forms/wh347.pdf>. Instructions for completing the payroll form are available at <http://www.dol.gov/whd/forms/wh347instr.htm>.

### 1.03 CONTINGENCY ALLOWANCE FOR TIME

- A. Paragraph 2.58 of the CICC 7360-0/08 Miscellaneous Construction Contract is hereby amended to provide a Contingency Allowance for time extension not to exceed ten percent of the original Contract Duration pursuant to a written request by Contractor for a time extension for an Excusable Delay, as described in Paragraph 2.58 of the 7360 Miscellaneous Construction Contract, that affects the critical path schedule of the Contract or any previously approved changes. The request

must be accompanied by written documentation that supports the justification of a time extension and is subject to review and concurrence by the department Engineer, or designee. If approved, a Contract Contingency Allowance Expenditure Authorization will be created for execution by all parties. Once executed the time extension will adjust the scheduled completion date. The cumulative total of all Contingency Allowance time extensions shall not exceed ten percent of the original Contract Duration rounded off to the next whole number.

1.04 WEATHER DELAYS

A. Schedule of Anticipated Weather Delay Days

1. The following schedule of average climatic range, based on National Oceanic and Atmospheric Administration (NOAA) normal data (1981-2010 Monthly Normals; GHCN Daily ID: USW00012839; MIAMI INTL AP, FL), will be used as the standard baseline for monthly evaluations of weather delays for this Contract.

Schedule of Anticipated Weather Delay Days												
Month	JAN	FEB	MAR	APR	MAY	JUN	JUL	AUG	SEP	OCT	NOV	DEC
Days	3	4	4	4	7	12	11	13	13	8	4	4

2. The above schedule provides the anticipated number of days each month during which construction activity exposed to weather conditions is expected to be prevented and suspended by cause of adverse weather. Suspension of construction activity for the number of days listed in the schedule, for each month, is included in the Work and is not eligible for extension of Contract Time. The Work Progress Schedule submitted by Contractor must reflect these anticipated adverse weather delays in all weather dependent activities.

B. Extension of Contract Time for Adverse Weather Days in Excess of the Standard Baseline

1. If the basis exists, in accordance with the Conditions of the Contract, for a claim for extension of time, an extension of time on the basis of weather may be granted only for the number of Weather Delay Days in a month that are in excess of the number of days listed above for that month in the Schedule of Anticipated Adverse Weather Delay Days.
2. Adverse Weather Day is defined, for the purpose of this Article, as the occurrence of one or more of the following weather conditions within a twenty-four (24) hour day that prevents scheduled critical path construction activity exposed to weather conditions:

Precipitation in excess of one-tenth inch (0.10").

Temperatures that do not rise above that required for the day's construction activity, if such temperature requirement is specified or accepted as standard industry practice.

Sustained wind in excess of twenty-five (25) miles per hour.

3. Adverse Weather Day may include "dry-out" days, resulting from precipitation that occurs beyond the Anticipated Weather Delay Days for the month, only if there is a hindrance to site access or sitework and Contractor has taken all reasonable accommodations to avoid such hindrance; and, at a rate no greater than 1 make-up day for each precipitation day (or consecutive days) that total 1.0 inch or more of precipitation.

4. A Weather Delay Day may be counted by the Engineer, if adverse weather prevents work on the Project for fifty percent (50%) or more of the Contractor's normal scheduled work day and critical path construction activities were included in the day's schedule, including a weekend day or holiday approved by the Engineer with construction activity scheduled that day.
5. No additional compensation will be made for weather delays.

C. Contractor Documentation and Submittals

1. Organize claim to facilitate evaluation by calendar month and submit in accordance with the claims submittal requirements of the Contract Documents. Documentation is required for each Adverse Weather Day that results in a Weather Delay. Identify the number of days claimed for the month that exceeds the Schedule of Anticipated Adverse Weather Delays. Documentation must include:
  2. Daily jobsite work logs showing which and to what extent critical path construction activities have been affected by adverse weather.
  3. Daily weather data, obtained from the nearest NOAA weather station or other independently verified source approved by Engineer at beginning of the Project, to support claim for time extension. NOAA Global Historical Climatology Network (GHCN) Daily data may be obtained from the NOAA website at <http://www.ncdc.noaa.gov/cdo-web/search>.
4. If an extension of Contract Time is appropriate and approved by the Department, such extension will be made in accordance with the requirements of the Contract Documents.

1.05 ADDITIONAL FUNDING SOURCE PROVISIONS

- A. This Contract is federally funded, contractor must comply with all the requirements of the federal agency providing the funds, inclusive of FHWA, FEMA or any contract that is part of a Local Agency Program (LAP) Agreement.
- B. This Additional Contract Compliance supplements and is made part of these Contract Documents to be used for fully or partially federally funded contract and the conditions of the Local Agency Program (LAP) Agreement.
- C. The provisions in this section shall apply to the (Contractor/Vendor/Consultant), its officers, agents, employees, subcontractors and suppliers. The (Contractor/Vendor/Consultant) shall incorporate the provisions in this Article in all subcontracts and all other agreements executed by the (Contractor/Vendor/Consultant) in connection with the performance of this contract.
- D. Miami-Dade County (MDC), a recipient of funds for the construction of highways and bridges, is required to ensure EEO contract compliance on all highway construction projects. Contractors who participate on MDC federally funded contracts in whole or in part are required to comply with certain Equal Employment Opportunity (EEO), Disadvantaged Business Enterprises (DBE), On-the-Job Training (OJT) and Wage Rate Special Provisions to be eligible for participation.
- E. When required by the contract documents the Contractor will make use of FDOT Material Testing Facilities, for material certifications and will comply with the submittal requirements of the Materials Acceptance and Certification System (MAC). See MAC below for more information.

## 1.06 LAWS & REGULATIONS

- A. Contractor to follow all laws and regulations necessary to be in compliance with federal regulations.
1. 23 CFR 230: Prescribes the policies, procedures, and guidance for equal opportunity on federal construction contracts.
  2. 23 CFR 230.111: Prescribes State agency requirements for an On-the-Job Training program for all Federal Aid Highway construction contracts. Other regulations governing State compliance programs include: Title VI of the Civil Rights Act of 1964, Federal Aid Required Contract Provisions, the Davis Bacon Act, the Copeland Act and the Contract Work Hours and Safety Standards Act., FHWA-1273 as per 23 CFR 633, 23 CFR Part 230 and 49 CFR Part 26 authorize FDOT to take sanctions for the condition and state of noncompliance.
  3. 23 CFR 140: Prescribes the policies, procedures, and guidance to develop, conduct, and administer supportive services assistance programs for minority, disadvantaged, and women business enterprises.
  4. 28 CFR 35: Prohibits discrimination on the basis of disability by public entities.
  5. 29 CFR 1630: Regulates implementation of the Equal Employment provisions of ADA.
  6. 29 CFR, Part 3 (Copeland "Anti-Kickback" Law): Copeland "Anti-Kickback" Act (18 U.S.C. 874 and 40 U.S.C. 276c) - All contracts in excess of \$2,000 shall comply with the provision for compliance with the Copeland "Anti-Kickback" Act (18 U.S.C. 874), as supplemented by Department of Labor regulations (29 CFR Part 3, "Contractors and Subcontractors on Public Building or Public Work Financed in Whole or in Part by Loans or Grants from the United States"). The Act provides that each contractor or subcontractor shall be prohibited from inducing, by any means, any person employed in the construction, completion, or repair of public work, to give up any part of the compensation to which (s) he is otherwise entitled.
  7. 40 USC 3141-4147 (Davis-Bacon Act of 1931 and as amended) Under the provisions of this Act, contractors or their subcontractors are to pay workers employed directly upon the site of the work no less than the locally prevailing wages and fringe benefits paid on projects of a similar character. The Davis-Bacon Act directs the Secretary of Labor to determine such local prevailing wage rates which can be found in a document named "General Decision Number".
  8. 41 CFR 60: The purpose of the regulations in this part is to achieve the aims of Parts II, III, and IV of Executive Order 11246 for the promotion and insuring of equal opportunity for all persons, without regard to race, color, religion, sex, national origin, disability or status as a Vietnam era or special disabled veteran employed or seeking employment with government contractors or with contractors performing under federally assisted construction contracts. This legislation bans discrimination and requires contractors and subcontractors to take affirmative action to ensure that all individuals have an equal opportunity for employment. Contractor must comply with all the requirements of Presidential Executive Order 11246. Executive order can be found under Appendix B of these Supplementary Conditions and are being made part of these Contract Documents.
  9. 41 CFR 60.1: Clarifies the existing requirement that a nonexempt construction contractor's total construction workforce is covered under 41 CFR 60 even though some employees may perform work on or nonfederal assisted contracts.
  10. 40 USC Chapter 37, Sections 3701-3708 (Contract Work Hours and Safety Standards Act): Where applicable, all contracts awarded in excess of \$2,000 for construction contracts that



involve the employment of mechanics or laborers shall include a provision for compliance with Subparts 102 and 107 of the Contract Work Hours and Safety Standards Act (40 U.S.C. 327-333), as supplemented by Department of Labor regulations (29 CFR Part 5). Under Subsection 102 of the Act, each contractor shall be required to compute the wages of every mechanic and laborer on the basis of a standard work week of 40 hours. Work in excess of the standard work week is permissible provided that the worker is compensated at a rate of not less than 1.5 times the basic rate of pay for all hours worked in excess of 40 hours in the work week. Subpart 107 of the Act is applicable to construction work and provides that no laborer or mechanic shall be required to work in surroundings or under working conditions, which are unsanitary, hazardous or dangerous.

11. 42 USC 12101: Regulates Equal Opportunity for individuals with disabilities.
12. 49 CFR 26: Regulates participation by Disadvantaged Business Enterprises.
13. Equal Pay Act of 1963: A law which requires equal pay between the sexes on jobs that is equal in skill, effort, and responsibility.
14. Equal Pay Act of 1976 (EPA): This legislation prohibits discrimination on account of sex in the payment of wages by employers engaged in commerce or in the production of goods for commerce.
15. Rehabilitation Act of 1973: Prohibits job discrimination because of disabilities and requires affirmative action to employ and advance in employment qualified individuals with disabilities who with reasonable accommodation can perform the essentials of a job.
16. Title I of the Americans with Disabilities Act (ADA) of 1990: Prohibits employment discrimination against qualified individuals with disabilities.
17. Title VI of the Civil Rights Act Of 1964: Prohibits discrimination on the basis of race, color, or national origin in all programs or activities receiving federal funding.
18. Title VII of the Civil Rights Act of 1964 (and as amended): Prohibits employment discrimination based on race, color, religion, sex and national origin.
19. Title VIII of the Civil Rights Act of 1964 (and as amended): The portion of the Civil Rights Act of 1968 (also known as the Fair Housing Act), as amended by the Housing and Community Development Act of 1974 and the Fair Housing Amendments Act of 1988, which prohibits discrimination in the sale, lease, rental, advertising, financing, and brokerage services of housing and real property based on race, color, religion, sex, national origin, disability, or familial status.

#### 1.07 CONTRACTOR RESPONSIBILITIES

- A. The prime contractor is responsible for compliance by any subcontractor or lower tier subcontractor. The contractor, subrecipient, subcontractor or rental agreement shall not discriminate on the basis of race, color, national origin, or sex in the performance of contracts.
- B. The contractor, subrecipient or subcontractor shall not discriminate on the basis of race, color, national origin, or sex in the performance of this contract. The contractor shall carry out applicable requirements of 49 CFR Part 26 in the award and administration of DOT-assisted contracts. Failure by the contractor to carry out these requirements is a material breach of this contract, which may result in the termination of this contract or such other remedy as the recipient deems appropriate.

C. The prime contractor shall be responsible for compliance by any subcontractor or lower tier subcontractor with the Required Contract Provisions. In the event a prime contractor defaults on a contract and their contract compliance data is incomplete or incorrect, the Resident Compliance Specialist will proceed with all noncompliance communications and actions such that the surety company and/or the successor contractor are fully aware of the conditions. A surety company is exempt from contract compliance reporting requirements but is responsible for ensuring that the successor contractor carries out the requirements.

D. Authority of the U.S. Comptroller General.

1. The U.S. Comptroller General and his representatives the authority:
2. To examine any records of the Contractor or any of its subcontractors, or any State or Local agency administering such contract, that directly pertain to, and involve transactions relating to, the contract or subcontract; and
3. to interview any officer or employee of the Contractor or any of its subcontractors, or of any State or Local government agency administering the Contract, regarding such transactions.

E. Authority of the U.S. Inspector General.

1. The Inspector General or any representatives has the authority to examine any records or interview any employee or officers working on this Contract. The Contractor is advised that representatives of the Inspector General have the authority to examine any record and interview any employee or officer of the Contractor, its subcontractors or other firms working on this Contract. Nothing in this Section shall be interpreted to limit or restrict in any way any existing authority of an Inspector General.
2. County and the Contractor agree to comply with s.20.055(5), Florida Statutes, and to incorporate in all subcontracts the obligation to comply with s.20.055(5), Florida Statutes.

It is the duty of every state officer, employee, agency, special district, board, commission, contractor, and subcontractor to cooperate with the inspector general in any investigation, audit, inspection, review, or hearing pursuant to this section.

F. Withholding payment for failure to comply with federal aid requirements.

1. The Department will withhold progress payments from the Contractor for failure to comply with the requirements of this Article.

G. Costs for Compliance with federal aid requirements

1. The costs for complying with federal aid requirements, including the cost of preparing and submitting Employment Reports, are incidental to the Contract. The Contractor shall include all related costs in the unit Bid prices of the Contract.

H. Certification of Inclusion of FHWA-1273

1. The prime contractor is responsible for ensuring that FHWA 1273, Required Contract Provisions for Federal Aid Construction, is inserted, in its entirety, in all contractor agreements including each subcontract and any lower tier subcontract or purchase order that may in turn be made. The Required Contract Provisions of FHWA 1273 is located under Appendix B of these Supplementary Conditions and it is being made part of these Contract Documents. The FHWA-1273 Electronic version, dated July 5 2022 is posted on the FDOT's website at the

following URL address: [https://fdotwww.blob.core.windows.net/sitefinity/docs/default-source/programmanagement/implemented/urlinspecs/files/fhwa1273.pdf?sfvrsn=1cd7961f\\_12](https://fdotwww.blob.core.windows.net/sitefinity/docs/default-source/programmanagement/implemented/urlinspecs/files/fhwa1273.pdf?sfvrsn=1cd7961f_12).

2. Take responsibility to obtain this information and comply with all requirements posted on this website up through five calendar days before the opening of bids.
3. If the FDOT website cannot be accessed, contact FDOT Department's Specifications Office Web Coordinator at (850) 414-4101.
4. Submit to the Engineer a complete and executed Certification of Inclusion of FHWA-1273 form, included in Section 2 (Solicitation Forms) of these Contract Documents, for each subcontractor, supplier, or Rental Company, including every lower tier provider, used in the performance of this Contract. Contractor is responsible for the compliance of all required Contract Provisions by each subcontractor, lower tier subcontractor, or supplier.

I. Exclusions

1. Contractor Purchased Equipment for State or Local Ownership pursuant to 23 CFR 140, 49 CFR Part 18, and 49 CFR Section 18.3; not allowed in this Contract.
2. Public Agencies in Competition with the Private Sector pursuant to 23 CFR 635.112 (e); not allowed in this Contract.
3. Publicly-Owned Equipment pursuant to the requirements of 23 CFR 635.106; not allowed in this Contract.
4. Salvage Credits pursuant to the requirements of 49 CFR 18.36; no salvage credit shall be provided.
5. State or Local Preference pursuant to the requirements of 23 CFR 635.117; not allowed in this Contract.
6. Foreign Contractor and Supplier Restriction pursuant to the requirements of 49 CFR 30; not allowed in this Contract.
7. State (Florida or other)-produced materials, 23 CFR 635.409 Preference programs mandating materials purchasing requirements or restrictions are not allowed under this contract
8. State/Local owned/Furnished/Designated materials, 23 CFR 635.407 Tax saving programs are not allowed under this contract.
9. Comply with Section 20.055(5), Florida Statutes, and incorporate in all subcontracts the obligation to comply with Section 20.055(5), Florida Statutes.
10. Owner Force Account contracting pursuant to 23 CFR 635B under 635.205; not allowed in this Contract.
11. Veteran's preferences are not allowed under this contract.
12. Proprietary/Sole Sourced Materials are not allowed under this contract.
13. As stated on 23 CFR 635.127 and Section 1.2.7 of FDOT CPAM, Incentive/Disincentive Clauses, are not applicable to this contract.

14. As stated on 23 CFR 635.117, Indian Preference on Federal-Aid Projects, is not applicable to this contract.

J. Labor, Employment, and Convict Produced Materials

1. Labor and employment.

Pursuant to 23 CFR 635.117:

2. No construction work shall be performed by convict labor at the work site or within the limits of any Federal-aid highway construction project from the time of award of the contract or the start of work on force account until final acceptance of the work by the STD unless it is labor performed by convicts who are on parole, supervised release, or probation.
3. No procedures or requirement shall be imposed by any State which will operate to discriminate against the employment of labor from any other State, possession or territory of the United States, in the construction of a Federal-aid project.
4. The selection of labor to be employed by the contractor on any Federal-aid project shall be by the contractor without regard to race, color, religion, sex, national origin, age, or handicap and in accordance with 23 CFR part 230, 41 CFR part 60 and Exec. Order No. 11246 (Sept. 24, 1965), 3 CFR 339 (1964-1965), as amended.
5. The advertisement or call for bids on any contract for the construction of a project located on the Federal-aid system either shall include the minimum wage rates determined by the Secretary of Labor to be prevailing on the same type of work on similar construction in the immediate locality or shall provide that such rates are set out in the bidding documents and shall further specify that such rates are a part of the contract covering the project.

1.08 TITLE VI ASSURANCE – DOT 1050.2A, APPENDIX A AND APPENDIX E.

A. Appendix A:

1. During the performance of this Contract, the Contractor, for itself, its assignees and successors in interest (hereinafter referred to as the "Contractor") agrees as follows:
2. Compliance with Regulations: The Contractor shall comply with the Regulations relative to nondiscrimination in Federally-assisted programs of the US Department of Transportation (hereinafter, "USDOT") Title 49, Code of Federal Regulations, Part 21, as they may be amended from time to time, (hereinafter referred to as the Regulations), which are herein incorporated by reference and made a part of this Contract.
3. Nondiscrimination: The Contractor, with regard to the work performed by it during the Contract, shall not discriminate on the basis of race, color, national origin or sex in the selection and retention of sub-contractors, including procurements of materials and leases of equipment. The Contractor shall not participate either directly or indirectly in the discrimination prohibited by Section 21.5 of the Regulations, including employment practices when the Contract covers a program set forth in Appendix B of the Regulations.
4. Solicitations for subcontractors, including procurements of materials and equipment: In all solicitations either by competitive bidding or negotiation made by the Contractor for work to be performed under subcontract, including procurements of materials or leases of equipment, each potential subcontractor or supplier shall be notified by the Contractor of the Contractor's

obligations under this contract and the Regulations relative to nondiscrimination on the basis of race, color, national origin, or sex.

5. Information and Reports: The Contractor shall provide all information and reports required by the Regulations or directives issued pursuant thereto, and shall permit access to its books, records, accounts, other sources of information and its facilities as may be determined by the Florida Department of Transportation or the Federal Highway Administration, Federal Transit Administration, Federal Aviation Administration, and Federal Motor Carrier Safety Administration to be pertinent to ascertain compliance with such Regulations, order and instructions. Where any information required of a Contractor is in the exclusive possession of another who fails or refuses to furnish this information the Contractor shall so certify to the Florida Department of Transportation, or the Federal Highway Administration, Federal Transit Administration, Federal Aviation Administration, or Federal Motor Carrier Safety Administration as appropriate, and shall set forth what efforts it has made to obtain the information.
6. Sanctions for Noncompliance: In the event of the Contractor's noncompliance with the nondiscrimination provisions of this Contract, the Florida Department of Transportation shall impose such Contract sanctions as it or the Federal Highway Administration, Federal Transit Administration, Federal Aviation Administration, or Federal Motor Carrier Safety Administration may determine to be appropriate, including, but not limited to:
7. Withholding of payments to the Contractor under the Contract until the Contractor complies, or
8. Cancellation, termination or suspension of the Contract, in whole or in part.
9. Incorporation of Provisions: The Contractor shall include the provisions of this appendix in every subcontract, including procurements of materials and leases of equipment, unless exempt by the Regulations, or directives issued pursuant thereto. The Contractor shall take such action with respect to any subcontract or procurement as the Florida Department of Transportation or the Federal Highway Administration, Federal Transit Administration, Federal Aviation Administration, or Federal Motor Carrier Safety Administration may direct as a means of enforcing such provisions including sanctions for noncompliance, provided, however, that, in the event a Contractor becomes involved in, or is threatened with, litigation with a subcontractor or supplier as a result of such direction, the Contractor may request the Florida Department of Transportation to enter into such litigation to protect the interests of the Florida Department of Transportation, and, in addition, the Contractor may request the United States to enter into such litigation to protect the interests of the United States.

B. Appendix E:

1. During the performance of this Contract, the Contractor, for itself, its assignees, and successors in interest (hereinafter referred to as the "Contractor" agrees to comply with the following non-discrimination statutes and authorities; including but not limited to:
2. Title VI of the Civil Rights Act of 1964 (42 U.S.C. § 2000d et seq., 78 stat. 252), (prohibits discrimination on the basis of race, color, national origin); and 49 CFR Part 21;
3. The Uniform Relocation Assistance and Real Property Acquisition Policies Act of 1970, (42 U.S.C. § 4601), (prohibits unfair treatment of persons displaced or whose property has been acquired of Federal or Federal-aid programs and projects);
4. Federal-Aid Highway Act of 1973, (23 U.S.C § 324 et seq.), (prohibits discrimination on the basis of sex);

5. Section 504 of the Rehabilitation Act of 1973 (29 U.S.C. § 794 et seq.), as amended, (prohibits discrimination on the basis of disability); and 49 CFR Part 27;
6. The Age Discrimination Act of 1975, as amended, (42 U.S.C. § 6101 et seq.), (prohibits discrimination on the basis of age);
7. Airport and Airway Improvement Act of 1982, (49 U.S.C. 471, Section 47123), as amended, (prohibits discrimination based on race, creed, color national origins or sex);
8. The Civil Rights Restoration Act of 1987 (PL 100-209), (Broadened the scope, coverage and applicability of Title VI of the Civil Rights Act of 1964, The Age Discrimination Act of 1975 and Section 504 of the Rehabilitation Act of 1973, by expanding the definition of the terms “programs or activities” to include all of the programs or activities of the Federal-aid recipients, sub-recipients and contractors, whether such programs or activities are Federally funded or not);
9. Titles II and III of the Americans with Disabilities Act, which prohibits discrimination on the basis of disability in the operation of public entities, public and private transportation systems, places of public accommodation, and certain testing entities (42 U.S.C. §§ 12131 – 12189) as implemented by Department of Transportation regulations at 49 C.F.R. parts 37 and 38;
10. The Federal Aviation Administration’s Non-discrimination statute (49 U.S.C. § 47123) (prohibits discrimination on the basis of race, color, national origin, and sex);
11. Executive Order 12898, Federal Actions to Address Environmental Justice in Minority Populations and Low-Income Populations, which ensures non-discrimination against minority populations by discouraging programs, policies, and activities with disproportionately high and adverse human health or environmental effects on minority and low-income populations;
12. Executive Order 13166, Improving Access to Services for Persons with Limited English Proficiency, and resulting agency guidance, national origin discrimination includes discrimination because of limited English proficiency (LEP). To ensure compliance with Title VI, you must take reasonable steps to ensure that LEP persons have meaningful access to your programs (70 Fed. Reg. at 74087 to 74100);
13. Title IX of the Education Amendments of 1972, as amended, which prohibits discrimination based on sex in education programs, or activities (20 U.S.C. 1681 et seq.).

#### 1.09 ADDITIONAL SBE-CONST CONTRACT MEASURE REQUIREMENTS

- A. As per Miami-Dade County Ordinance No.'s 97-52 and 97-158; A.O. 3-22, a Small Business Enterprise - Construction (SBE-CONST) Contract Measure has not been established for this Project. Due to the funding source of this contract, a local preference is not allowed, however this project contains a statewide Disadvantaged Business Enterprise (DBE) race neutral aspirational goal of 10.65% percent. The Contractor shall comply with the requirements pursuant to 49 Code of Federal Regulations (CFR) Part 26 as implemented by the approved FDOT DBE Program.

#### 1.10 DISADVANTAGED BUSSINESS ENTERPRISE PROGRAM

- A. In accordance with 49 CFR 26.13 (b), The Contractor, sub-recipient or subcontractor shall not discriminate on the basis of race, color, national origin, or sex in the performance of this contract. The Contractor shall carry out applicable requirements of 49 CFR Part 26 in the award and

administration of federally assisted contracts. Failure by the Contractor to carry out these requirements is a material breach of this Contract, which may result in the termination of this Contract or such other remedy as the recipient deems appropriate, which may include, but is not limited to,

1. Withholding monthly progress payments;
2. Assessing sanctions;
3. Liquidated damages; and/or
4. Disqualifying the Contractor from future bidding as non-responsible.

B. DBE Records and Reports:

1. Submit the following through the Equal Opportunity Compliance System:

DBE Commitments - at or before the Pre-Construction Conference.

2. Report monthly, through the Equal Opportunity Compliance System on the Department's Website, actual payments (including retainage) made to DBEs for work performed with their own workforce and equipment in the area in which they are certified. Report payments made to all DBE and Minority Business Enterprise (MBE) subcontractors and DBE and MBE construction material and major suppliers.

3. The Equal Opportunity Office will provide instructions on accessing this system. Develop a record keeping system to monitor DBE affirmative action efforts which include the following:

The procedures adopted to comply with the DBE Program;

The number of subordinated Contracts on projects awarded to DBEs;

The dollar value of the Contracts awarded to DBEs;

The percentage of the dollar value of all subordinated Contracts awarded to DBEs as a percentage of the total Contract amount;

A description of the general categories of Contracts awarded to DBEs; and

The specific efforts employed to identify and award Contracts to DBEs.

4. Upon request, provide the records to the County for review. Maintain all such records for a period of five years following acceptance of final payment and have them available for inspection by the County, FDOT and the Federal Highway Administration.

C. Counting DBE Participation and Commercially Useful Functions:

1. 49 CFR Part 26.55 specifies when DBE credit shall be awarded for work performed by a DBE. DBE credit can only be awarded for work actually performed by DBEs themselves for the types of work for which they are certified. When reporting DBE Commitments, only include the dollars that a DBE is expected to earn for work they perform with their own workforce and equipment. Update DBE Commitments to reflect changes to the initial amount that was previously reported or to add DBEs not initially reported.
2. When a DBE participates in a contract, the value of the work is determined in accordance with 49 CFR Part 26.55, for example:

- a. The County will count only the value of the work performed by the DBE toward DBE goals. The entire amount of the contract that is performed by the DBE's own forces (including the cost of supplies, equipment and materials obtained by the DBE for the contract work) will be counted as DBE credit.
- b. The County will count the entire amount of fees or commissions charged by the DBE firm for providing a bona fide service, such as professional, technical, consultant, or managerial services or for providing bonds or insurance specifically required for the performance of a County-assisted contract, toward DBE goals, provided that the County determines the fees to be reasonable and not excessive as compared with fees customarily followed for similar services.
- c. When the DBE subcontracts part of the work of its contract to another firm, the County will count the value of the subcontracted work only if the DBE's subcontractor is itself a DBE. Work that a DBE subcontracts to a non-DBE firm does not count toward DBE goals.
- d. When a DBE performs as a participant in a joint venture, the County will count the portion of the dollar value of the contract equal to the distinct, clearly defined portion of the work the DBE performs with its own forces toward DBE goals.
- e. The Contractors shall ensure that only expenditures to DBEs that perform a commercially useful function (CUF) in the work of a contract may be counted toward the voluntary DBE goal.
- f. A DBE performs a commercially useful function when it is responsible for execution of the work of the contract and is carrying out its responsibilities by actually performing, managing, and supervising the work involved. To perform a commercially useful function, the DBE must also be responsible, with respect to materials and supplies used on the contract, for negotiating price, determining quality and quantity, ordering the material, and installing (where applicable) and paying for the material itself.
- g. Contractors wishing to use joint checks involving DBE credit must provide written notice to the FDOT District Contract Compliance Office prior to issuance of the joint check. The Contractor must also provide a copy of the notice to the DBE subcontractor and maintain a copy with the project records.
- h. To determine whether a DBE is performing a commercially useful function, the County will evaluate the amount of work subcontracted, industry practices, whether the amount the firm is to be paid under the contract is commensurate with the work it is actually performing and the DBE credit claimed for its performance of the work, and other relevant factors.
- i. A DBE does not perform a commercially useful function if its role is limited to that of an extra participant in a transaction, contract, or project through which funds are passed in order to obtain the appearance of DBE participation.
- j. If a DBE does not perform or exercise responsibility for at least 30% of the total cost of its contract with its own workforce, or if the DBE subcontracts a greater portion of the work of a contract than would be expected on the basis of normal industry practice for the type of work involved, the DBE has not performed a commercially useful function.

D. For further questions and/or concerns, please contact Mr. Stan Ford, FDOT District Six Compliance Manager with the details at: [Stan.Ford@dot.state.fl.us](mailto:Stan.Ford@dot.state.fl.us) or at (305) 640-7459.



1.11 PROMPT PAYMENTS AND RETAINAGE:

1. In addition to Miami-Dade County Sec. 2-8.1.4. Sherman S. Winn Prompt Payment Ordinance and Administrative Order No.: 3-19 Prompt Payment, contractors, subcontractors and the County must also meet the requirements of Title 49 CFR part 26.29 and 26.37 and the Florida Prompt Pay Act. Prime contractors must pay subcontractors, including DBE'S, for satisfactory performance of their contracts no later than 30 calendar days after the date on which the payment request or a "*proper invoice*" is stamped received. Further, the prime contractor will return retainage payments to the subcontractor, including DBE firms, within 30 days of the subcontractor's satisfactory completion of work.
2. Proper Invoice means an invoice which conforms to the present requirements of the County's finance system, which includes the issuance of a valid purchase order or contract as well as applicable change orders or amendments, and any rules promulgated from time to time by Administrative Order of the Mayor. A proper invoice must include a statement by the vendor/contractor waiving claims for extra direct and indirect costs or time associated with work preceding the date of the invoice, or a statement in sufficient detail containing all rights reserved for work already performed. All present requirements or future rules pertaining to the execution of a proper invoice are available to contractors at the pre-construction meeting.
3. In any case in which an improper invoice is submitted by a contractor, the County will, within ten (10) days after the improper invoice is received by it, notify the contractor that the invoice is improper and indicate what corrective action on the part of the vendor is needed to make the invoice proper.
4. In the event a dispute occurs between the contractor and the County concerning payment of an invoice, such disagreement shall be resolved not later than forty-five (45) days after the date on which the improper invoice was received by the County, and shall be concluded by final written decision of the Mayor or his or her designee(s), not later than sixty (60) days after the date on which the improper invoice was received by the County.
5. If the dispute is resolved in favor of the contractor, then interest shall begin to accrue as of the original date the payment became due.
6. All payments due from the County, and are not made by the appropriate due date as described above, shall bear interest from thirty (30) days after the appropriate due date at the rate of one (1) percent per month on the unpaid balance. One (1) month shall constitute a period beginning on any day of a month and ending on the same day of the following month. Any overdue period of less than one (1) month shall be considered as one (1) month in computing interest. Unpaid interest shall compound monthly.
7. The vendor must be responsible for preparing and delivering an invoice to the County for any interest accrued in order to receive the interest payment. The invoice must include the following:
  - a. Date proper invoice received by County, its applicable invoice number and amount.
  - b. Date punch list was completed.
  - c. Date and corresponding reference number of applicable purchase order, requisition or contract.
  - d. Payment due date.
  - e. Date interest commences.
  - f. Interest due at one percent per month on unpaid balance.

8. Contractor may not hold retainage from its subcontractors and is required to return any retainage payments to those subcontractors within 30 days after the subcontractor's work related to this contract is satisfactorily completed or within 30 days after incremental acceptance of the subcontractor's work by the County and contractor's receipt of the partial retainage payment related to the subcontractor's work, whichever comes first.

#### 1.12 MATERIALS ACCEPTANCE AND CERTIFICATION SYSTEM (MAC)

- A. When required by the Contract Documents and as per request of the funding administrator, Contractor must comply with the reporting requirements of the MAC system.
- B. Contractor is required to create a non-standard Job Guide Schedule (JGS) in MAC for the materials being certified by the FDOT. Once created, the non-standard JGS assigns the appropriate materials for County projects that don't have pay items entered in the FDOT construction management database.
- C. When the County employs a consultant (CEI firm) for materials testing:
  1. The CEI firm will need MAC access to make for data entry and data review of verification, independent verification and resolution sample and test data entry.
  2. The CEI firm will need personnel assigned the MAC system role of Project Administrator to:
    - Review the JGS entries for correctness and completeness.
    - Accept or reject the Contractor QC Plan.
    - Finalize project samples.
    - Create comparison packages, if applicable.
    - Respond to Materials Certification Review findings.
    - Process Materials Acceptance Resolution (MAR) issues.
- D. When the County performs the CEI materials testing duties directly, the County personnel will need MAC system role of Project Administrator to complete all of the items listed above under C.2.
  1. Contact the local MAC District Application Coordinator for additional information if access and training is needed the Mac contact Information can be found at <http://www.fdot.gov/materials/administration/resources/contacts/mac.shtm>
  2. Training can be found here at FDOT, State Materials Office - MAC Development Training Information at the following link: <http://www.fdot.gov/materials/mac/training/index.shtm>
  3. Access instructions can be found at: <http://www.fdot.gov/materials/mac/access/index.shtm>
  4. County projects not requiring FDOT Materials Certification will not be processed in MAC. The MAC process is very complex and in many cases not applicable to local agency specific materials certification processes. For further information or clarification, please contact Lorraine Moyle, State Local Program Administrator, FDOT, Office of Program Management, 605 Suwanee Street, M.S. 75; Tallahassee, FL 32399-0450. Phone (850) 414-4383. E-mail: [Lorraine.moyle@dot.state.fl.us](mailto:Lorraine.moyle@dot.state.fl.us).

#### 1.13 ON-THE-JOB TRAINING REQUIREMENTS

- A. Contractor to provide On-The-Job Training as part of the Contractor's equal employment opportunity affirmative action program aimed at developing full journeymen in the type of trade or job classification involved in the work. In the event the Contractor subcontracts a portion of the contract work, it shall determine how many, if any, of the trainees are to be trained by the subcontractor provided, that the Contractor shall retain the primary responsibility for meeting the training requirements imposed by this Article.
- B. Ensure that, when feasible, 25% of trainees in each occupation are in their first year of training. The Contractor shall incorporate the requirements of this Article into such subcontract.
- C. The number of trainees will be estimated on the number of calendar days of the contract, the dollar value, and the scope of work to be performed. The trainee goal will be finalized at a Post-Preconstruction Trainee Evaluation Meeting and the goal will be distributed among the work classifications based on the following criteria:
  - 1. Determine the number of trainees on Federal Aid Contract:

No trainees will be required for contracts with a Contract Time allowance of less than 275 calendar days.

If the Contract Time allowance is 275 calendar days or more, the number of trainees shall be established in accordance with the following chart:

Estimated Contract Amount	Trainees Required
\$2,000,000 or less	0
Over \$2,000,000 to \$4,000,000	2
Over \$4,000,000 to \$6,000,000	3
Over \$6,000,000 to \$12,000,000	5
Over \$12,000,000 to \$18,000,000	7
Over \$18,000,000 to \$24,000,000	9
Over \$24,000,000 to \$31,000,000	12
Over \$31,000,000 to \$37,000,000	13
Over \$37,000,000 to \$43,000,000	14
Over \$43,000,000 to \$49,000,000	15
Over \$49,000,000 to \$55,000,000	16
Over \$55,000,000 to \$62,000,000	17
Over \$62,000,000 to \$68,000,000	18
Over \$68,000,000 to \$74,000,000	19
Over \$74,000,000 to \$81,000,000	20
Over \$81,000,000 to \$87,000,000	21

Estimated Contract Amount	Trainees Required
Over \$87,000,000 to \$93,000,000	22
Over \$93,000,000 to \$99,000,000	23
Over \$99,000,000 to \$105,000,000	24
Over \$105,000,000 to \$112,000,000	25
Over \$112,000,000 to \$118,000,000	26
Over \$118,000,000 to \$124,000,000	27
Over \$124,000,000 to \$130,000,000	28
Over \$130,000,000 to *	
*One additional trainee per \$6,000,000 of estimated Construction Contract amount over \$130,000,000	

- D. Further, if the Contractor or subcontractor requests to utilize banked trainees as discussed later in this Article, a Banking Certificate will be validated at this meeting allowing credit to the Contractor for previously banked trainees. Banked credits of prime Contractors working as Subcontractors may be accepted for credit. The Contractor’s Project Manager, the Construction Project Engineer and the FDOT’s District Contract Compliance Manager will attend this meeting. Within ten days after the Post-Preconstruction Training Evaluation Meeting, the Contractor shall submit to the FDOT for approval an On-The-Job Training Schedule indicating the number of trainees to be trained in each selected classification and the portion of the Contract Time during which training of each trainee is to take place. This schedule may be subject to change if any of the following occur:
1. When a start date on the approved On-The-Job Training Schedule has been missed by 14 or more days;
  2. When there is a change in previously approved classifications;
  3. When replacement trainees are added due to voluntary or involuntary termination
- E. The revised schedule will be resubmitted to and approved by the FDOT’s District Contract Compliance Manager.
- F. The following criteria will be used in determining whether or not the Contractor has complied with this Section as it relates to the number of trainees to be trained:
1. Credit will be allowed for each trainee that is both enrolled and satisfactorily completes training on this Contract. Credit for trainees, over the established number for this Contract, will be carried in a “bank” for the Contractor and credit will be allowed for those surplus trainees in subsequent, applicable projects. A “banked” trainee is described as an employee who has been trained on a project, over and above the established goal, and for which the Contractor desires to preserve credit for utilization on a subsequent project.
  2. Credit will be allowed for each trainee that has been previously enrolled in the FDOT’s approved training program on another contract and continues training in the same job classification and completes their training on a different contract.

3. Credit will be allowed for each trainee who, due to the amount of work available in their classification, is given the greatest practical amount of training on the contract regardless of whether or not the trainee completes training.
  4. Credit will be allowed for any training position indicated in the approved On The Job Training Schedule, if the Contractor can demonstrate that made a good faith effort to provide training in that classification was made.
  5. No credit will be allowed for a trainee whose employment by the Contractor is involuntarily terminated unless the Contractor can clearly demonstrate good cause for this action.
- G. Training and upgrading of minorities, women and economically disadvantaged persons toward journeyman status is a primary objective of this Article. Accordingly, the Contractor shall make every effort to enroll minority trainees and women (e.g., by conducting systematic and direct recruitment through public and private sources likely to yield minority and women trainees) to the extent such persons are available within a reasonable area of recruitment. If a non-minority male is enrolled into the On-The-Job Training Program, the On-The-Job Training Notification of Personnel Action Form notifying the FDOT District Contract Compliance Manager of such action shall be accompanied by a disadvantaged certification or a justification for such action acceptable to the FDOT Department's District Contract Compliance Manager. The Contractor will be given an opportunity and will be responsible for demonstrating the steps that it has taken in pursuance thereof, prior to a determination as to whether the Contractor is in compliance with this Section. This training is not intended, and shall not be used, to discriminate against any applicant for training, whether a minority, woman or disadvantaged person.
- H. No employee shall be employed as a trainee in any classification in which they have successfully completed a training course leading to journeyman status, or have been employed as a journeyman. The Contractor may satisfy this requirement by including appropriate questions in the employee application or by other suitable means. Regardless of the method used, the Contractor's records should document the findings in each case.
1. The minimum length and type of training for each classification will be as established at the Post-Preconstruction Trainee Evaluation Meeting and approved by FDOT. Graduation to journeyman status will be based upon satisfactory completion of a Proficiency Demonstration set up at the completion of training and established for the specific training classification, completion of the minimum hours in a training classification range, and the employer's satisfaction that the trainee does meet journeyman status in the classification of training. Upon reaching journeyman status, the following documentation must be forwarded to FDOT District Contract Compliance Office:

Trainee Enrollment and Personnel Action Form

Proficiency Demonstration Verification Form indicating completion of each standard established for the classification signed by representatives of both the Contractor and the Department.

- I. The County and the Contractor shall establish a program that is tied to the scope of the work in the project and the length of operations providing it is reasonably calculated to meet the equal employment opportunity obligations of the Contractor and to qualify the average trainee for journeyman status in the classifications concerned, by at least, the minimum hours prescribed for a training classification. Furthermore, apprenticeship programs registered with the U.S. Department of Labor, Bureau of Apprenticeship and Training, or with a State apprenticeship agency recognized by the Bureau and training programs approved but not necessarily sponsored by the U.S. Department of Labor, Manpower Administration, Bureau of Apprenticeship and Training shall also be considered acceptable provided it is being administered in a manner consistent with the

equal employment obligations of Federal Aid highway construction contract. Approval or acceptance of a training schedule shall be obtained from FDOT prior to commencing work on the classifications covered by the program.

- J. A voluntary On-The-Job Training Program is available to a Contractor which has been awarded a state funded project. Through this program, the Contractor will have the option to train employees on state funded projects for "banked credit" as discussed previously in this provision, to be utilized on subsequent Federal Aid Projects where training is required. Those Contractors availing themselves of this opportunity to train personnel on state funded projects and bank trainee hours for credit shall comply with all training criteria set forth in this Article for Federal Aid Projects; voluntary banking may be denied by FDOT if staff is not available to monitor compliance with the training criteria.
- K. It is the intention of these provisions that training is to be provided in the construction crafts rather than clerk-typists or secretarial type positions. Training is permissible in lower level management positions such as office engineers, estimators, etc., where the training is oriented toward construction applications. Training in the laborer classifications, except Common/General Laborer, may be permitted provided that significant and meaningful training is provided and approved by FDOT District Contract Compliance Office.
- L. When approved in advance by FDOT District Contract Compliance Manager, credit will be given for training of persons in excess of the number specified herein under the current contract or a Contractor will be allowed to bank trainees who have successfully completed a training program and may apply those trainees to a training requirement in subsequent project(s) upon approval of FDOT's District Contract Compliance Manager. This credit will be given even though the Contractor may receive training program funds from other sources, provided such other source do not specifically prohibit the Contractor from receiving other form of compensation. Offsite training is permissible as long as the training is an integral part of an approved training program and does not compromise a significant part of the overall training. Credit for offsite training indicated above may only be made to the Contractor when it does one or more of the following and the trainees are concurrently employed on a Federal Aid Project:
  - 1. Contributes to the cost of the training,
  - 2. Provides the instruction to the trainee,
  - 3. Pays the trainee's wages during the offsite training period.
- M. The Contractor shall compensate the trainee at no less than the laborer rate established in the Contract at the onset of training. The compensation rate will be increased to the journeyman's wage upon graduation from the training program for the remainder of the time the trainee works in the classification in which they were trained.
- N. The Contractor shall furnish the trainee a copy of the program they will follow in providing the training. The Contractor shall provide each trainee with a certification showing the type and length of training satisfactorily completed. The Contractor shall enroll a trainee in one training classification at a time to completion before the trainee can be enrolled in another classification on the same project.
- O. The Contractor shall maintain records to document the actual hours each trainee is engaged in training on work being performed as a part of this Contract.
- P. The Contractor shall submit to FDOT District Contract Compliance Manager a copy of an On-The-Job Training Notification of Personnel Action form no later than seven days after the effective date of the action when the following actions occur: a trainee is transferred on the project, transferred

from the project to continue training on another contract, completes training, is upgraded to journeyman status or voluntarily terminates or is involuntary terminated from the project.

- Q. The Contractor shall furnish to FDOT District Contract Compliance Manager a copy of a Monthly Time Report for each trainee. The Monthly Time Report for each month shall be submitted no later than the tenth day of the subsequent month. The Monthly Time Report shall indicate the phases and sub-phases of the number of hours devoted to each proficiency.
- R. Highway or Bridge Carpenter Helper, Mechanic Helper, Rodman/Chainman, and Timekeeper classifications will not be approved for the On-The-Job Training Program.
- S. The number of trainees may be distributed among the work classifications on the basis of the Contractor's needs and the availability of journeymen in the various classifications within a reasonable area of recruitment.
- T. The Contractor will have fulfilled the responsibilities of this Specification when acceptable training has been provided to the trainee as specified above.

#### 1.14 COMMUNITY WORKFORCE PROGRAM

- A. In accordance with Miami-Dade County Code §2-1701 and amended by Ordinance No. 13-66 the Community Workforce Program (CWP) does not apply for this Project.
- B. Due to the funding source of this contract, no procedures or requirement will be imposed by Miami-Dade County which will operate to discriminate against the employment of labor from any other State, possession or territory of the United States, in the construction of this Federal-aid project in order to be in compliance with the use of Local Hiring Preferences as stated under 23 USC 112, 23 CFR 635.117(b), and Headquarters memorandum - "Local Hiring Preferences," April 20, 1994.

#### 1.15 CLEARINGHOUSE FOR POSTING NOTICE OF JOB OPPORTUNITIES

- A. The subject project is federally funded, therefore Clearinghouse for Posting Notice of Job Opportunities is not applicable.

#### 1.16 RESIDENTS FIRST TRAINING AND EMPLOYMENT PROGRAM COMPLIANCE

- A. The subject project is federally funded, therefore RFTE program is not applicable.

#### 1.17 EMPLOY MIAMI-DADE PROGRAM

- A. The subject project is federally funded, therefore Employ Miami-Dade program is not applicable.

#### 1.18 ACCEPTANCE TESTS

- A. Replace Article 2.89 of the CICC 7360-0/08 Miscellaneous Construction Contract with the following:
- B. When Contractor informs Engineer that the Work is ready for inspection and testing, Engineer may request, from a County approved laboratory, the tests necessary to confirm that the required material, compaction, or work specifications are met. If the results of the tests reveal that the

applicable specifications have not been met, Contractor, without additional compensation, must perform, to the satisfaction of Engineer, all work necessary to meet the applicable specifications and is responsible for the costs of all re-testing required by Engineer and the Contract Documents.

- C. The Department will pay the laboratory for the first test (pass or fail); any re-testing will be the responsibility of Contractor. The Department will only pay for re-testing when authorized, in writing, by Engineer.
- D. Contractor must comply with the conditions of the agreement between Miami-Dade County and Laboratory.

#### 1.19 CHANGE ORDER PROCEDURES AND BASIS FOR PAYMENT

- A. Extra Work shall result in an equitable adjustment (increase or decrease) to the applicable RPQ representing the reasonable cost or the reasonable financial savings related to the change in Work. Extra Work may also result in an equitable adjustment in the RPQ schedule for performance for both the Extra Work and any other Work affected by the Extra Work.
- B. The County shall initiate the Extra Work procedure by a notice to Contractor outlining the proposed Extra Work. Upon receipt of the notice to proceed with the Extra Work, the Contractor is required to immediately start the Extra Work. The Contractor is required to obtain permission for an extension to start the Extra Work if it is beyond the Contractor's ability to start within the allotted timeframe.
- C. The Contractor is required to provide the Project Manager with a detailed Change Order Proposal, if an Owner's Representative has been identified, which shall include requested revisions to the Contract, including but not limited to adjustments in the RPQ price and schedules for performance for the applicable RPQ. The change to the RPQ shall not exceed \$100,000 or 10% of original RPQ, whichever is less. The Contractor is required to provide sufficient data in support of the cost proposal demonstrating reasonableness. In furtherance of this obligation, the County may require that the Contractor submit any or all of the following: a cost breakdown of material costs, labor costs, labor rates by trade, and Work classification and overhead rates in support of Contractor's Change Order Proposal. The Contractor's Change Order Proposal must include any schedule revisions and an explanation of the cost and schedule impact of the extra Work on the project. If the Contractor fails to notify the Project Manager of the schedule changes associated with a Notice of Proposed Change Order by submitting a revised schedule document, it will be deemed to be an acknowledgment by Contractor that the proposed Extra Work will not have any scheduling consequences. The Contractor agrees the Change Order Proposal will in no event include a combined profit and home office overhead rate in excess of fifteen (15%) percent of the direct labor and material costs, unless the Project Manager determines that the complexity and risk of the Extra Work is such that an additional factor is appropriate. The Change Order Proposal may be accepted or modified by negotiations between the Contractor and the County. If an agreement on the Extra Work is reached, both parties shall execute the Extra Work order in writing. The execution by the Contractor of the Extra Work order shall serve as a release of the County from all claims and liability to the Contractor relating to, or in connection with, the Extra Work, including any impact, and any prior acts, neglect or default of the County relating to the Extra Work.

#### 1.20 MIAMI-DADE COUNTY'S USER ACCESS PROGRAM (UAP).

- A. This project is federally funded, therefore UAP does not apply for this project.



1.21 PUBLIC RECORDS AND CONTRACTS FOR SERVICES PERFORMED ON BEHALF OF MIAMI-DADE COUNTY.

- A. The Contractor shall comply with the Public Records Laws of the State of Florida, including but not limited to,
  - 1. Keeping and maintaining all public records that ordinarily and necessarily would be required by Miami-Dade County (County) in order to perform the service.
  - 2. Providing the public with access to public records on the same terms and conditions that the County would provide the records and at a cost that does not exceed the cost provided in Chapter 119, F.S., or as otherwise provided by law
  - 3. Ensuring that public records that are exempt or confidential and exempt from public records disclosure requirements are not disclosed except as authorized by law; and
  - 4. Meeting all requirements for retaining public records and transferring, at no cost, to the County all public records in possession of the Contractor upon termination of the contract and destroying any duplicate public records that are exempt or confidential and exempt from public records disclosure requirements upon such transfer.
- B. In addition, all records stored electronically must be provided to the County in a format that is compatible with the information technology systems of the County. Failure to meet any of these provisions or to comply with Florida's Public Records Laws as applicable shall be a material breach of the agreement and shall be enforced in accordance with the terms of the agreement.
- C. For questions regarding the application of chapter 119, Florida Statutes, to The Contractor's Duty to Provide Public Records relating to this contract, contact the Custodian of Public Records at (305) 375-4735; [isd-vss@miamidade.gov](mailto:isd-vss@miamidade.gov); 111 NW 1 Street, suite 1300, Miami, Florida 33128.

1.22 NONDISCRIMINATION

- A. During the performance of this Contract, Contractor agrees to not discriminate against any employee or applicant for employment because of race, color, religion, ancestry, national origin, sex, pregnancy, age, disability, marital status, familial status, sexual orientation, gender identity or gender expression, status as victim of domestic violence, dating violence or stalking, or veteran status, and on housing related contracts the source of income, and will take affirmative action to ensure that employees and applicants are afforded equal employment opportunities without discrimination. Such action shall be taken with reference to, but not limited to: recruitment, employment, termination, rates of pay or other forms of compensation, and selection for training or retraining, including apprenticeship and on the job training.
- B. By entering into this Contract, the Contractor attests that it is not in violation of the Americans with Disabilities Act of 1990 (and related Acts) or Miami-Dade County Resolution No. R-385-95. If the Contractor or any owner, subsidiary or other firm affiliated with or related to the Contractor is found by the responsible enforcement agency or the County to be in violation of the Act or the Resolution, such violation shall render this Contract void. This Contract shall be void if the Contractor submits a false affidavit pursuant to this Resolution or the Contractor violates the Act or the Resolution during the term of this Contract, even if the Contractor was not in violation at the time it submitted its affidavit.

## 1.23 CONTRACTOR DUE DILIGENCE AFFIDAVIT

- A. In accordance with Board of County Commissioners Resolution 63-14, Contractor, as a condition of award, must submit Contractor Due Diligence Affidavit Form on any contract that exceeds \$1 million, or that is otherwise subject to Board approval.
  - 1. Affidavit is attached in Section 2 of these Solicitation Documents and must be included in the solicitation package. Form requires that Contractors attest to the following under oath:
    - a. All of the lawsuits that have been filed against that entity, its directors, partners, principals, and/or board members, based on breach of contract by that entity in the five years prior to bid or proposal submittal, including the case name and number and the disposition of the case;
    - b. Any instances in the five years prior to bid or proposal submittal where that entity has been defaulted and a brief description of the circumstances; and
    - c. All of the instances in the five years prior to bid or proposal submission where that entity has been debarred or received a formal notice of non-compliance or non-performance, such as a notice to cure or a suspension from participating or bidding for contracts, whether related to Miami-Dade County or not.
- B. It is the responsibility of the Contractor to return the fully executed Affidavit at the time of bid or proposal submittal. This affidavit will be used as an additional measure of due diligence prior to award of a contract.
- C. In accord with Resolution No. R-828-19, the County reserves the right to request from any bidder the disclosure of any lawsuits which include allegations of discrimination in the last ten years prior to date of solicitation, the disposition of such lawsuits, or statement that there are no such lawsuits.
- D. As per Miami-Dade County Resolution R-1181-18, Submit OSHA form 300 containing a list of the company's work-related injury and illness data; and OSHA inspection data, for the previous three years, for the contractor and first tier subcontractors. The Department of Labor Occupational and safety Health Administration (OSHA) Form 300, 300A and 301 can be found under Appendix D of these Supplementary Conditions.

## 1.24 CLAIMS

- A. Amend Paragraph 2.78 of the CICC 7360-0/08 Miscellaneous Construction Contract by adding the following:
- B. Notice of Claims
  - 1. The Contractor will not be entitled to additional time or compensation otherwise payable for any act or failure to act by the Department, the happening of any event or occurrence, or any other cause, unless he shall have given the Project manager a written notice of claim therefore as specified in this article.
  - 2. The Contractor shall provide immediate verbal notification with written confirmation within forty-eight (48) hours of any potential claims and of the anticipated time and/or cost impacts resulting thereof. The written notice of claim shall set forth the reasons for which the Contractor believes additional compensation and/or time will or may be due, the nature of the costs involved and the approximate amount of the potential claim.

3. It is the intention of this article, that differences between the parties arising under and by virtue of the Contract shall be brought to the attention of the Project Manager at the earliest possible time in order that such matters may be settled, if possible, or other appropriate action promptly taken.
4. The notice requirements of this article are in addition to those required in other articles of these Contract Documents, inclusive of the conditions listed under the MCC Plan.
5. The Contractor shall segregate all costs associated with each individual claim including but not limited to labor, equipment, material, subcontractor and supplier costs, and all other costs related to the claim. In the event that the Contractor has multiple claims, the Contractor will segregate each claim individually including the respective costs associated with each claim. Failure to segregate claims and their respective costs will be grounds for the Department's rejection of the claim. No "total cost claims" shall be allowed under this Contract.
6. The Contractor must maintain a cost accounting system as a condition for making a claim against the Department. The cost accounting system must segregate the costs of the work under the Contract (non-claims-related) from claims-related and other Contractor costs through the use of a job cost ledger and be otherwise in compliance with general accounting principles.
7. If the Department decides to pay all or part of a claim for which notice was not timely made, the Department does not waive the right to enforce the notice requirements in connection with any other claim.
8. Inasmuch as the notice of claim requirements of this article are intended to enable the Project Manager to investigate while facts are fresh and to take action to minimize or avoid a claim which might be filed thereafter, the Contractor's failure to make the required notice on time is likely to disadvantage the Department. Therefore, a claim that does not comply with the notice requirements above shall not be considered unless the Contractor submits with his claim proof showing that the Department has not been prejudiced by the Contractor's failure to so comply and, in the event the Department has been prejudiced by the Contractor's failure to submit a timely notice of claim, the Department will reduce any equitable adjustment claimed by the Contractor to reflect the damage.

#### C. Claim Submittals

1. Claims or requests for equitable adjustments filed by the Contractor shall be filed in full accordance with this article no later than 30 calendar days after the act giving rise to the claim and in sufficient detail to enable the Department to ascertain the basis and amount of said claims. In the case of continuing or on-going claim events, the Contractor shall be allowed to periodically amend his claim to more accurately reflect the impact of said claim, until the end of the claim event. No claims for additional compensation, time extension or for any other relief under the Contract shall be recognized, processed, or treated in any manner unless the same is presented in accordance with this Article. Failure to present and process any claim in accordance with this Article shall be conclusively deemed a waiver, abandonment or relinquishment of any such claim, it being expressly understood and agreed that the timely presentation of claims, in sufficient detail to allow proper investigation and prompt resolution thereof, is essential to the administration of this Contract.
2. The Department will review and evaluate the Contractor's claims. It will be the responsibility of the Contractor to furnish, when requested by the Project manager, such further information and details as may be required to determine the facts or contentions involved in his claims. The cost of claims preparation or Change Order negotiations shall not be reimbursable under this Contract.

3. Any work performed by the Contractor prior to Notice-to-Proceed (NTP) shall not be the basis for a claim from the Contractor of any kind.
4. Each claim must be certified by the Contractor as required by the Miami-Dade Code, False Claims Act (see Code Section 21-255, et seq.), and accompanied by all materials required by Miami-Dade County Code Section 21-257. A "certified claim" shall be made under oath by a person duly authorized by the claimant, and shall contain a statement that:
  - a. The claim is made in good faith;
  - b. The claim's supporting data is accurate and complete to the best of the person's knowledge and belief;
  - c. The amount of the claim accurately reflects the amount that the claimant believes is due from the Department; and
  - d. The certifying person is duly authorized by the claimant to certify the claim.
5. In order to substantiate time-related claims (delays, disruptions, impacts, etc.), the Contractor shall, if applicable and as determined by the Department, submit, in triplicate, the following information:
  - a. Copy of Contractor's notice of claim in accordance with this article. Failure to submit the notice is sufficient grounds to deny the claim.
  - b. The approved, as-planned Schedule in accordance with the applicable section of the Contract Documents and computer storage media, if applicable.
  - c. The as-built Schedule reflecting changes to the approved schedule up to the time of the impact in question and computer storage media if applicable.
  - d. The basis for the duration of the start and finish dates of each impact activity and the reason for choosing the successor and predecessor events affected in the schedule shall be explained. Also, the basis for the duration of any lead/lags inserted into the schedule and the duration in related activity duration shall be explained.
  - e. A marked-up as-built Schedule indicating the causes responsible for changes between the as-planned and as-built schedule and establishing the required cause and effect relationships.
  - f. After indicating specific time related changes on the as-built schedule, the documentation must be segregated into separate packages with each package documenting a specific duration change identified previously. This documentation package shall include Change Orders, Change Notices, Work Orders, written directions, meeting minutes, etc., related to the change in duration.
  - g. Any loss of efficiency, acceleration, disruption and loss of productivity claims shall be compensated as part of the Liquidated Indirect Costs paid for compensable, excusable delays and mark-up on Direct Cost of changes as allowed by the Contract. Total cost and modified total cost claims will not be accepted and the Contractor agrees to waive the right to seek recovery by these methods. The claimed delay shall not result from a cause specified in the Contract Documents as a non-excusable delay.
  - h. The Contractor assumes all risk for the following items, none of which shall be the subject of any claim and none of which shall be compensated for except as they may have been included in the compensation described under Liquidated Indirect Costs:
    - 1) Home office expenses or any Direct Costs incurred allocated from the headquarters of the Contractor;
    - 2) Loss of anticipated profits on this or any other project;

- 3) Loss of bonding capacity or capability;
  - 4) Losses due to other projects not bid upon;
  - 5) Loss of business opportunities;
  - 6) Loss of productivity on this or any other project;
  - 7) Loss of interest income on funds not paid;
  - 8) Costs to prepare, negotiate or prosecute claims and
  - 9) Costs spent to achieve compliance with applicable laws and ordinances (excepting only sales taxes paid shall be reimbursable expense subject to the provisions of the Contract Documents).
- i. All non-time-related claim items for additional compensation for Direct Costs shall be properly documented and supported with copies of invoices, time sheets, rental agreements, crew sheets and the like.
  - j. Cost information shall be submitted in sufficient detail to allow for review. The basis for the budgeted or actual costs shall include man-hours by trade, labor rates, material and equipment costs etc. These costs shall be broken down by pay.
  - k. The documentation for budgeted cost shall, as a minimum, include:
    - 1) Copies of all the Contractor's bid documents, bid quotes, faxed quotes, etc.
    - 2) Copies of all executed subcontracts.
    - 3) Other related budget documents as requested by the Project Manager.
  - l. The documentation for actual cost shall, as a minimum, include:
    - 1) Time Sheets.
    - 2) Materials invoices
    - 3) Equipment invoices
    - 4) Subcontractors' payments
    - 5) Other related documents as required by the Project Manager.
  - m. The Contractor shall make all his books, employees, work sites and records available to the Department or its representatives for inspection and audit.
6. No payment shall be made to the Contractor by the Department for loss of anticipated profit(s) from any deleted work.
  7. As indicated above, the Project Manager and the Field Representative shall be allowed full and complete access to all personnel, documents, work sites or other information reasonably necessary to investigate any claim. Within sixty (60) days after a claim has been received, the claim shall either be rejected with an explanation as to why it was rejected or acknowledged. Once the claim is acknowledged, the parties shall attempt to negotiate a satisfactory settlement of the claim, which settlement shall be included in a subsequent Work Order or Change Order. If the parties fail to reach an agreement on a recognized claim, the Department shall pay to the Contractor the amount of money it deems reasonable, less any appropriate retention, to compensate the Contractor for the recognized claim.
  8. Failure of the Contractor to make a specific reservation of rights regarding any such disputed amounts in the body of the Change Order which contains the payment shall be construed as a waiver, abandonment, or relinquishment of all claims for additional monies resulting from the claims embodied in said Change Order. However, once the Contractor has properly reserved

rights to any claim, no further reservations of rights shall be required and the Contractor shall not be required to repeat the reservation in any subsequent change order. Prior reservation of rights may however be modified, by express reference, in subsequent change orders. Notwithstanding the aforementioned, at the time of final payment under the Contract, the Contractor shall specify all claims which have been denied and all claims for which rights have been reserved in accordance with this section. Failure to so specify any particular claim shall be constructed as a waiver, abandonment, or relinquishment of such claim.

## 1.25 DISPUTES

- A. Amend Paragraph 2.81 of the CICC 7360-0/08 Miscellaneous Construction Contract by adding the following:
- B. Disputes
  - 1. The following provisions shall govern disputes under this Contract unless the Special Provisions to this Contract contain the requirement for the use of an alternate dispute resolution method. For example, for large projects of great complexity, a Dispute Review Board (DRB) may be employed by the Department to settle disputes in lieu of the Department Director or Office of the Mayor (OOM) designee as specified below. In this case, the DRB alternative shall be specified by the Department in the Special Provisions and, if utilized, shall supersede this dispute provision.
    - a. In the event the Contractor and the Department are unable to resolve their differences concerning any determination made by the Project Manager or Department on any dispute or claim arising under or relating to the Contract (referred to in this Section as a "Dispute"), either the Contractor or the Department may initiate a dispute in accordance with the procedure set forth in this article. Exhaustion of these procedures shall be a precondition to any lawsuit permitted hereunder.
    - b. For contracts with a value of \$5 million or less, all Disputes under this Contract shall be decided by the Department Director or his designee. For contracts valued at more than \$5 million, Disputes shall be decided by a designee appointed by the OOM. Decisions rendered by the Department Director or OOM designee shall not be binding but shall be admissible in a court of competent jurisdiction.
    - c. As soon as practicable, the Department Director or OOM designee shall adopt a schedule for the Contractor and the Department to file written submissions stating their respective positions and the bases therefore. The written submissions shall include copies of all documents and sworn statements in affidavit form from all witnesses relied on by each party in support of its position. Within 20 working days of the date on which such written submissions are filed, the Department Director or OOM designee shall afford each party an opportunity to present a maximum of one hour of argument. The Department Director or OOM designee may decide the Dispute on the basis of the affidavits and other written submissions if, in his opinion, there is no issue of material fact and the party is entitled to a favorable resolution pursuant to the terms of this Contract. As part of such decision, the Department Director or OOM designee shall determine the timeliness and sufficiency of each notice of claim and claim at issue as provided in this article. The Department Director or OOM designee shall have the authority to rule on questions of law, including disputes over contract interpretation, and to resolve claims, or portions of claims, via summary judgment where there are no disputed issues of material fact. Furthermore, the Department Director or OOM designee is authorized by both parties to strike elements of claims seeking relief or damages not available under the contract (such as, but not limited to, claims for lost

profits, off-site overhead, loss of efficiency or productivity claims or claim's preparation costs) by summary disposition.

- d. In the event that the Department Director or OOM designee determines that the affidavits or other written submissions present issues of material fact, he shall allow the presentation of evidence in the form of lay or expert testimony directed solely to the issues which he may specifically identify to require factual resolution. The testimonial portion of the process shall not exceed one day in duration per side, including opening statements and closing arguments, if allowed by the Department Director or OOM designee at his reasonable discretion.
- e. No formal discovery shall be allowed in connection with any proceeding under this article. Notwithstanding the foregoing, both parties agree that all of the audit, document inspection, information and documentation requirements set forth elsewhere in this contract shall remain in force and effect throughout the proceeding. The Department Director or OOM designee shall not schedule the hearing until both parties have made all their respective records available for inspection and reproduction and the parties have been afforded reasonable time to analyze the records. The continued failure of a party to comply with the document inspection, examination, or submission requirements set forth in this contract shall constitute a waiver of that party's claims and/or defenses, as applicable. Hearsay evidence shall be admissible but shall not form the sole basis for any finding of fact. Failure of any party to participate on a timely basis, to cooperate in the proceedings, or to furnish evidence in support or defense of a claim shall be a criteria in determining the sufficiency and validity of a claim.
- f. The Department Director or OOM designee shall issue a written decision within 15 working days after conclusion of any testimonial proceeding and, if no testimonial proceeding is conducted, within 45 days of the filing of the last written submission. This written decision shall set forth the reasons for the disposition of the claim and a breakdown of any specific issues or subcontractor claims. As indicated previously, the decision of the Department Director or OOM designee is not binding on the parties, but will be admissible in a court of competent jurisdiction.
- g. If either party wishes to protest the decision of the Department Director or OOM designee, such party may commence an action in a court of competent jurisdiction, within the periods prescribed by law, it being understood that the review of the court shall be limited to the question of whether or not the Department Director or OOM designee's determination was arbitrary and capricious, unsupported by any competent evidence, or so grossly erroneous to evidence bad faith.
- h. Pending final decision of a dispute hereunder, the Contractor shall proceed diligently with the performance of the Contract and in accordance with the Department's interpretation. Any presentation or request by the Contractor under this article will be subject to the same requirements for Submittal of Claims in this article.

## 1.26 EXTRA WORK

- A. The following Subarticle replaces the following items: Article 2.83, Extra Work and Payment Therefore, of the Special Conditions of the MCC 7360 Plan,:
  1. Contractor may be asked to perform extra work, for which there is no price included in the Proposal, wherever it is deemed necessary or desirable by the Engineer to satisfactorily complete the Project as contemplated, and such extra work must be performed promptly in accordance with the Specifications and as directed by the Engineer, provided, however, that before any extra work is begun, a written order from the Engineer to do the work shall be given to the Contractor. No extra work will be paid for unless ordered in writing.

2. All changed or added work so authorized shall be performed by the Contractor at the time and in the manner specified.
3. The Change Order shall include, as a minimum:
  - a. Scope of work to be added, deleted or modified;
  - b. Cost of work to be added, deleted or modified;
  - c. The Contract time extension or reduction in contract time in the case of deleted work required to perform the work to be added, deleted or modified;
  - d. Full release of claims associated with the Contract through the date of the change order, or a reservation of claims identified as to each claim reserved, the scope of the work, the maximum cost of the work, and the maximum number of days of Contract time requested, shall be specified.
4. The Work Order shall include, at a minimum:
  - a. Scope of work to be added, deleted or modified;
  - b. Cost of work to be added, deleted or modified;
  - c. The Contract time extension required to perform the work to be added, deleted or modified;
  - d. Full release of claims associated with the work order work, or a reservation of claims identified as to each claim reserved, the scope of the work, the maximum cost of the work, and the maximum number of days of Contract time requested, shall be specified.

B. Allowable Costs for Extra Work

1. The following Subarticle replaces the following items: Article 2.83, Extra Work and Payment Therefore, of the Special Conditions of the MCC 7360 Plan:
2. The Engineer may direct in writing that extra work be done and, at the Engineer's sole discretion, the Contractor will be paid pursuant to an agreed Supplemental Agreement or in the following manner:
  - a. Labor and Burden: The Contractor will receive payment for actual costs of direct labor and burden for the additional or unforeseen work. Labor includes foremen actually engaged in the work; and will not include project supervisory personnel nor necessary on-site clerical staff, except when the additional or unforeseen work is a controlling work item and the performance of such controlling work item actually extends completion of the project due to no fault of the Contractor. Compensation for project supervisory personnel, but in no case higher than a Project Manager's position, shall only be for the pro-rata time such supervisory personnel spent on the contract. In no case shall an officer or director of the Company, nor those persons who own more than 1% of the Company, be considered as project supervisory personnel, direct labor or foremen hereunder.
  - b. Payment for burden shall be limited solely to the following:



Table 1.25 B	
Item	Rate
FICA	Rate established by Law
FUTA/SUTA	Rate established by Law
Medical Insurance	Actual
Holidays, Sick & Vacation benefits	Actual
Retirement benefits	Actual
Workers Compensation	Rates based on the National Council on Compensation Insurance basic rate tables adjusted by Contractor's actual experience modification factor in effect at the time of the additional work or unforeseen work.
Per Diem	Actual but not to exceed State of Florida's rate
Insurance*	Actual
*Compensation for Insurance is limited solely to General Liability Coverage and does not include any other insurance coverage (such as, but not limited to, Umbrella Coverage, Automobile Insurance, etc.).	

3. At the Pre-construction conference, certify to the Engineer the following:
  - a. A listing of on-site clerical staff, supervisory personnel and their pro-rated time assigned to the contract,
  - b. Actual Rate for items listed in Table 4-3.2.1,
  - c. Existence of employee benefit plan for Holiday, Sick and Vacation benefits and a Retirement Plan, and,
  - d. Payment of Per Diem is a company practice for instances when compensation for Per Diem is requested. Such certification must be made by an officer or director of the Contractor with authority to bind the Contractor. Timely certification is a condition precedent to any right of the Contractor to recover compensations for such costs, and failure to timely submit the certification will constitute a full, complete, absolute and irrevocable waiver by the Contractor of any right to recover such costs. Any subsequent changes shall be certified to the Engineer as part of the cost proposal or seven calendar days in advance of performing such extra work.
  
4. Materials and Supplies: For materials accepted by the Engineer and used on the project, the Contractor will receive the actual cost of such materials incorporated into the work, including Contractor paid transportation charges (exclusive of equipment as hereinafter set forth). For supplies reasonably needed for performing the work, the Contractor will receive the actual cost of such supplies.

5. Equipment: For any machinery or special equipment (other than small tools), including fuel and lubricant, the Contractor will receive 100% of the "Rental Rate Blue Book" for the actual time that such equipment is in operation on the work, and 50% of the "Rental Rate Blue Book" for the time the equipment is directed to standby and remain on the project site, to be calculated as indicated below. The equipment rates will be based on the latest edition (as of the date the work to be performed begins) of the "Rental Rate Blue Book for Construction Equipment" or the "Rental Rate Blue Book for Older Construction Equipment," whichever is applicable, as published by Machinery Information Division of PRIMEDIA Information, Inc. (version current at the time of bid), using all instructions and adjustments contained therein and as modified below. On all projects, the Engineer will adjust the rates using regional adjustments and Rate Adjustment Tables according to the instructions in the Blue Book.
6. Allowable Equipment Rates will be established as set out below:
  - a. Allowable Hourly Equipment Rate =  $\text{Monthly Rate} / 176 \times \text{Adjustment Factors} \times 100\%$ .
  - b. Allowable Hourly Operating Cost =  $\text{Hourly Operating Cost} \times 100\%$ .
  - c. Allowable Rate Per Hour = Allowable Hourly Equipment Rate + Allowable Hourly Operating Cost.
  - d. Standby Rate = Allowable Hourly Equipment Rate  $\times 50\%$ .
7. The Monthly Rate is The Basic Machine Rate Plus Any Attachments. Standby rates will apply when equipment is not in operation and is directed by the Engineer to standby at the project site when needed again to complete work and the cost of moving the equipment will exceed the accumulated standby cost. Standby rates will not apply on any day the equipment operates for eight or more hours. Standby payment will be limited to only that number of hours which, when added to the operating time for that day equals eight hours. Standby payment will not be made on days that are not normally considered work days on the project.
8. The County will allow for the cost of transporting the equipment to and from the location at which it will be used. If the equipment requires assembly or disassembly for transport, the County will pay for the time to perform this work at the rate for standby equipment.
9. Equipment may include vehicles utilized only by Labor, as defined above.
10. Indirect Costs, Expenses, and Profit: Compensation for all indirect costs, expenses, and profit of the Contractor, including but not limited to overhead of any kind, whether jobsite, field office, division office, regional office, home office, or otherwise, is expressly limited to the greater of either (1) or (2) below:
11. Solely a mark-up of 17.5% on the payments in (a) through (c), above.
12. Bond: The Contractor will receive compensation for any premium for acquiring a bond for such additional or unforeseen work at the original Contract bond rate paid by the Contractor. No compensation for bond premium will be allowed for additional or unforeseen work paid by the Department via initial contingency pay item.
13. The Contractor will be allowed a markup of 10% on the first \$50,000 and a markup of 5% on any amount over \$50,000 on any subcontract directly related to the additional or unforeseen work. Any such subcontractor mark-up will be allowed only by the prime Contractor and a first tier subcontractor, and the Contractor must elect the markup for any eligible first tier subcontractor to do so.

14. Solely the formula set forth below and only as applied solely as to such number of calendar days of entitlement that are in excess of ten cumulative calendar days as defined below.

$$D = \frac{A \times C}{B}$$

Where     A= Original Contract Amount  
           B= Original Contract Time  
           C= 8%  
           D= Average Overhead Per Day

15. Cumulative Calendar Days is defined as the combined total number of calendar days granted as time extensions due to either extra work, excluding overruns to existing contract items, that extend the duration of the project or delay of a controlling work item caused solely by the Department, or the combined total number of calendar days for which a claim of entitlement to a time extension due to delay of a controlling work item caused solely by the Department is otherwise ultimately determined to be in favor of the Contractor.
16. No compensation, whatsoever, will be paid to the Contractor for any jobsite overhead and other indirect impacts when the total number of calendar days granted for time extension due to delay of a controlling work item caused solely by the Department is, or the total number of calendar days for which entitlement to a time extension due to delay of a controlling work item caused solely by the Department is otherwise ultimately determined in favor of the Contractor to be, equal to or less than ten calendar days and the Contractor also fully assumes all monetary risk of any and all partial or single calendar day delay periods, due to delay of a controlling work item caused solely by the Department, that when combined together are equal to or less than ten calendar days and regardless of whether monetary compensation is otherwise provided for hereunder for one or more calendar days of time extension entitlement for each calendar day exceeding ten calendar days. All calculations under this provision shall exclude weather days, Holidays, and Special Events.
17. Further, for (1) or (2) above, in the event there are concurrent delays to one or more controlling work items, one or more being caused by the Department and one or more being caused by the Contractor, the Contractor shall be entitled to a time extension for each day that a controlling work item is delayed by the Department but shall have no right to nor receive any monetary compensation for any indirect costs for any days of concurrent delay.

#### 1.27 WARRANTY OF CONSTRUCTION

- A. For a period of one year, except as provided below, from the date of Final Acceptance, the Contractor warrants that the Work conforms to the Contract requirements and the RPQ requirements and is free of any patent and/or latent defect of the material or workmanship.
1. Exception to the above year warranty:
- a. Where the manufacturer of material provides a warranty in excess of one (1) year, the Contractor shall provide an assignment of warranty to the County with the manufacturer's written authorization. Contractors shall be obligated to provide to the County copies of all manufacturer's warranties and guarantees. Where the County specifies in an RPQ a warranty greater than one (1) year, such warranty will only be for the specified RPQ.

- b. The warranty hereunder shall be in addition to whatever rights the County may have under law. The Contractor's obligation under this warranty shall be at its own cost and expense, to promptly repair or replace (including cost of removal and installation), that item (or part of component thereof) which proves defective or fails to comply with the Contract within the warranty period such that it complies with the Contract.
- c. In the event the Contractor fails to repair or replace defective Work in accordance with the terms of the Contract, the RPQ, and this warranty, the County shall have the right to collect such costs incurred or withhold the cost of the anticipated repairs by offsetting the amount against any payment due the Contractor under any contract between the County and the Contractor.
- d. As specified in the construction documents. All guarantees and warranties under the Contract are fully enforceable by the County acting in its own name.

#### 1.28 CONFLICT OF INTEREST

- A. In addition to the requirements of Sec. 2-11.1. – Miami-Dade County Conflict of Interest and Code of Ethics Ordinance. (January 2016). The contractor must also comply with the federal and state requirements for conflict of interest:
  - 1. Neither the Recipient nor any of its contractors or their subcontractors shall enter into any contract, subcontract or arrangement in connection with the Project or any property included or planned to be included in the Project in which any member, officer or employee of Miami-Dade County (the County) during tenure or for 2 years thereafter has any interest, direct or indirect. If any such present or former member, officer or employee involuntarily acquires or had acquired prior to the beginning of tenure any such interest, and if such interest is immediately disclosed to the County, the County, with prior approval of the FDOT, may waive the prohibition contained in this paragraph provided that any such present member, officer or employee shall not participate in any action by the County relating to such contract, subcontract or arrangement.
  - 2. Contractor is required to insert the language below in all contracts entered into in connection with the Project and its subcontracts:

"No member, officer or employee of Miami Dade County during his tenure or for 2 years thereafter shall have any interest, direct or indirect, in this contract or the proceeds thereof."
  - 3. The provisions of this paragraph shall not be applicable to any agreement between the County and its fiscal depositories or to any agreement for utility services the rates for which are fixed or controlled by a governmental agency.

APPENDIX A OF THE SUPPLEMENTARY CONDITIONS  
DAVIS BACON WAGES

"General Decision Number: FL20230125 01/20/2023

Superseded General Decision Number: FL20220125

State: Florida

Construction Type: Heavy

County: Miami-Dade County in Florida.

HEAVY CONSTRUCTION PROJECTS (Including Sewer and Water Lines)

Note: Contracts subject to the Davis-Bacon Act are generally required to pay at least the applicable minimum wage rate required under Executive Order 14026 or Executive Order 13658. Please note that these Executive Orders apply to covered contracts entered into by the federal government that are subject to the Davis-Bacon Act itself, but do not apply to contracts subject only to the Davis-Bacon Related Acts, including those set forth at 29 CFR 5.1(a)(2)-(60).

If the contract is entered into on or after January 30, 2022, or the contract is renewed or extended (e.g., an option is exercised) on or after January 30, 2022:	. Executive Order 14026 generally applies to the contract. . The contractor must pay all covered workers at least \$16.20 per hour (or the applicable wage rate listed on this wage determination, if it is higher) for all hours spent performing on the contract in 2023.
If the contract was awarded on or between January 1, 2015 and January 29, 2022, and the contract is not renewed or extended on or after January 30, 2022:	. Executive Order 13658 generally applies to the contract. . The contractor must pay all covered workers at least \$12.15 per hour (or the applicable wage rate listed on this wage determination, if it is higher) for all hours spent performing on that contract in 2023.

The applicable Executive Order minimum wage rate will be adjusted annually. If this contract is covered by one of the Executive Orders and a classification considered necessary for performance of work on the contract does not appear on this wage determination, the contractor must still submit a conformance request.

Additional information on contractor requirements and worker protections under the Executive Orders is available at <http://www.dol.gov/whd/govcontracts>.

Modification Number	Publication Date
0	01/06/2023
1	01/20/2023

ELEC0349-007 09/01/2021

	Rates	Fringes
ELECTRICIAN.....	\$ 37.61	11.72

---

ENGI0487-017 07/01/2013

	Rates	Fringes
OPERATOR: Backhoe (Except Loader Combo).....	\$ 28.32	8.80
OPERATOR: Crane All Tower Cranes (Must have 2 operators) Mobile, Rail, Climbers, Static-Mount; All Cranes with Boom Length 150 Feet & Over (With or without jib) Friction, Hydro, Electric or Otherwise; Cranes 150 Tons & Over (Must have 2 operators); Cranes with 3 Drums (When 3rd drum is rigged for work); Gantry & Overhead Cranes; Hydro Cranes Over 25 Tons but not more than 50 Tons (Without Oiler/Apprentice); Hydro/Friction Cranes without Oiler/Apprentices when Approved by Union; & All Type of Flying Cranes; Boom Truck.....	\$ 29.05	8.80
Cranes with Boom Length Less than 150 Feet (With or without jib); Hydro Cranes 25 Tons & Under, & Over 50 Tons (With Oiler/Apprentice); Boom Truck.....	\$ 28.32	8.80
OPERATOR: Drill.....	\$ 25.80	8.80
OPERATOR: Loader.....	\$ 25.64	8.80
OPERATOR: Oiler.....	\$ 22.99	8.80

---

\* IRON0272-005 10/01/2022

	Rates	Fringes
IRONWORKER, STRUCTURAL.....	\$ 27.00	14.77

---

LAB01652-004 05/01/2018

	Rates	Fringes
LABORER: Grade Checker.....	\$ 22.05	7.27

---

PAIN0365-007 06/01/2021

	Rates	Fringes
PAINTER: Brush, Roller and Spray.....	\$ 20.21	12.38

---

	Rates	Fringes
CARPENTER, Includes Form Work....	\$ 17.00	2.51
CEMENT MASON/CONCRETE FINISHER...	\$ 16.61	5.52
LABORER: Common or General.....	\$ 13.09 **	1.26
LABORER: Landscape.....	\$ 7.25 **	0.00
LABORER: Power Tool Operator (Hand Held Drills/Saws, Jackhammer and Power Saws Only).....	\$ 10.63 **	2.20
OPERATOR: Asphalt Paver.....	\$ 11.59 **	0.00
OPERATOR: Backhoe Loader Combo.....	\$ 16.10 **	2.44
OPERATOR: Bulldozer.....	\$ 14.95 **	0.81
OPERATOR: Excavator.....	\$ 21.16	1.67
OPERATOR: Grader/Blade.....	\$ 16.00 **	2.84
OPERATOR: Mechanic.....	\$ 14.32 **	0.00
OPERATOR: Roller.....	\$ 10.95 **	0.00
OPERATOR: Scraper.....	\$ 11.00 **	1.74
OPERATOR: Trackhoe.....	\$ 20.92	5.50
OPERATOR: Tractor.....	\$ 10.54 **	0.00
TRUCK DRIVER, Includes Dump Truck.....	\$ 9.60 **	0.00
TRUCK DRIVER: Lowboy Truck.....	\$ 12.73 **	0.00
TRUCK DRIVER: Off the Road Truck.....	\$ 12.21 **	1.97

-----  
WELDERS - Receive rate prescribed for craft performing operation to which welding is incidental.

=====  
\*\* Workers in this classification may be entitled to a higher minimum wage under Executive Order 14026 (\$16.20) or 13658 (\$12.15). Please see the Note at the top of the wage determination for more information.

Note: Executive Order (EO) 13706, Establishing Paid Sick Leave for Federal Contractors applies to all contracts subject to the Davis-Bacon Act for which the contract is awarded (and any solicitation was issued) on or after January 1, 2017. If this contract is covered by the EO, the contractor must provide employees with 1 hour of paid sick leave for every 30 hours they work, up to 56 hours of paid sick leave each year. Employees must be permitted to use paid sick leave for their



own illness, injury or other health-related needs, including preventive care; to assist a family member (or person who is like family to the employee) who is ill, injured, or has other health-related needs, including preventive care; or for reasons resulting from, or to assist a family member (or person who is like family to the employee) who is a victim of, domestic violence, sexual assault, or stalking. Additional information on contractor requirements and worker protections under the EO is available at

<https://www.dol.gov/agencies/whd/government-contracts>.

Unlisted classifications needed for work not included within the scope of the classifications listed may be added after award only as provided in the labor standards contract clauses (29CFR 5.5 (a) (1) (ii)).

-----

The body of each wage determination lists the classification and wage rates that have been found to be prevailing for the cited type(s) of construction in the area covered by the wage determination. The classifications are listed in alphabetical order of ""identifiers"" that indicate whether the particular rate is a union rate (current union negotiated rate for local), a survey rate (weighted average rate) or a union average rate (weighted union average rate).

#### Union Rate Identifiers

A four letter classification abbreviation identifier enclosed in dotted lines beginning with characters other than ""SU"" or ""UAVG"" denotes that the union classification and rate were prevailing for that classification in the survey. Example: PLUM0198-005 07/01/2014. PLUM is an abbreviation identifier of the union which prevailed in the survey for this classification, which in this example would be Plumbers. 0198 indicates the local union number or district council number where applicable, i.e., Plumbers Local 0198. The next number, 005 in the example, is an internal number used in processing the wage determination. 07/01/2014 is the effective date of the most current negotiated rate, which in this example is July 1, 2014.

Union prevailing wage rates are updated to reflect all rate changes in the collective bargaining agreement (CBA) governing this classification and rate.

#### Survey Rate Identifiers

Classifications listed under the ""SU"" identifier indicate that no one rate prevailed for this classification in the survey and the published rate is derived by computing a weighted average rate based on all the rates reported in the survey for that classification. As this weighted average rate includes all rates reported in the survey, it may include both union and non-union rates. Example: SULA2012-007 5/13/2014. SU indicates the rates are survey rates based on a weighted average calculation of rates and are not majority rates. LA indicates the State of Louisiana. 2012 is the year of survey on which these classifications and rates are based. The next number, 007 in the example, is an internal number used in producing the wage determination. 5/13/2014 indicates the survey completion date for the classifications and rates under that identifier.

Survey wage rates are not updated and remain in effect until a new survey is conducted.

#### Union Average Rate Identifiers

Classification(s) listed under the UAVG identifier indicate that no single majority rate prevailed for those classifications; however, 100% of the data reported for the classifications was union data. EXAMPLE: UAVG-OH-0010 08/29/2014. UAVG indicates that the rate is a weighted union average rate. OH indicates the state. The next number, 0010 in the example, is an internal number used in producing the wage determination. 08/29/2014 indicates the survey completion date for the classifications and rates under that identifier.

A UAVG rate will be updated once a year, usually in January of each year, to reflect a weighted average of the current negotiated/CBA rate of the union locals from which the rate is based.

---

#### WAGE DETERMINATION APPEALS PROCESS

1.) Has there been an initial decision in the matter? This can be:

- \* an existing published wage determination
- \* a survey underlying a wage determination
- \* a Wage and Hour Division letter setting forth a position on a wage determination matter
- \* a conformance (additional classification and rate) ruling

On survey related matters, initial contact, including requests for summaries of surveys, should be with the Wage and Hour National Office because National Office has responsibility for the Davis-Bacon survey program. If the response from this initial contact is not satisfactory, then the process described in 2.) and 3.) should be followed.

With regard to any other matter not yet ripe for the formal process described here, initial contact should be with the Branch of Construction Wage Determinations. Write to:

Branch of Construction Wage Determinations  
Wage and Hour Division  
U.S. Department of Labor  
200 Constitution Avenue, N.W.  
Washington, DC 20210

2.) If the answer to the question in 1.) is yes, then an interested party (those affected by the action) can request review and reconsideration from the Wage and Hour Administrator (See 29 CFR Part 1.8 and 29 CFR Part 7). Write to:

Wage and Hour Administrator  
U.S. Department of Labor  
200 Constitution Avenue, N.W.  
Washington, DC 20210

The request should be accompanied by a full statement of the interested party's position and by any information (wage

payment data, project description, area practice material, etc.) that the requestor considers relevant to the issue.

3.) If the decision of the Administrator is not favorable, an interested party may appeal directly to the Administrative Review Board (formerly the Wage Appeals Board). Write to:

Administrative Review Board  
U.S. Department of Labor  
200 Constitution Avenue, N.W.  
Washington, DC 20210

4.) All decisions by the Administrative Review Board are final.

=====

END OF GENERAL DECISIO"

APPENDIX B OF THE SUPPLEMENTARY CONDITIONS  
FHWA-1273 REQUIRED CONTRACT PROVISIONS FOR FEDERAL AID  
CONSTRUCTION CONTRACTS

**REQUIRED CONTRACT PROVISIONS  
FEDERAL-AID CONSTRUCTION CONTRACTS**

- I. General
- II. Nondiscrimination
- III. Non-segregated Facilities
- IV. Davis-Bacon and Related Act Provisions
- V. Contract Work Hours and Safety Standards Act Provisions
- VI. Subletting or Assigning the Contract
- VII. Safety: Accident Prevention
- VIII. False Statements Concerning Highway Projects
- IX. Implementation of Clean Air Act and Federal Water Pollution Control Act
- X. Certification Regarding Debarment, Suspension, Ineligibility and Voluntary Exclusion
- XI. Certification Regarding Use of Contract Funds for Lobbying
- XII. Use of United States-Flag Vessels:

**ATTACHMENTS**

A. Employment and Materials Preference for Appalachian Development Highway System or Appalachian Local Access Road Contracts (included in Appalachian contracts only)

**I. GENERAL**

1. Form FHWA-1273 must be physically incorporated in each construction contract funded under title 23, United States Code, as required in 23 CFR 633.102(b) (excluding emergency contracts solely intended for debris removal). The contractor (or subcontractor) must insert this form in each subcontract and further require its inclusion in all lower tier subcontracts (excluding purchase orders, rental agreements and other agreements for supplies or services). 23 CFR 633.102(e).

The applicable requirements of Form FHWA-1273 are incorporated by reference for work done under any purchase order, rental agreement or agreement for other services. The prime contractor shall be responsible for compliance by any subcontractor, lower-tier subcontractor or service provider. 23 CFR 633.102(e).

Form FHWA-1273 must be included in all Federal-aid design-build contracts, in all subcontracts and in lower tier subcontracts (excluding subcontracts for design services, purchase orders, rental agreements and other agreements for supplies or services) in accordance with 23 CFR 633.102. The design-builder shall be responsible for compliance by any subcontractor, lower-tier subcontractor or service provider.

Contracting agencies may reference Form FHWA-1273 in solicitation-for-bids or request-for-proposals documents, however, the Form FHWA-1273 must be physically incorporated (not referenced) in all contracts, subcontracts and lower-tier subcontracts (excluding purchase orders, rental agreements and other agreements for supplies or services related to a construction contract). 23 CFR 633.102(b).

2. Subject to the applicability criteria noted in the following sections, these contract provisions shall apply to all work

performed on the contract by the contractor's own organization and with the assistance of workers under the contractor's immediate superintendence and to all work performed on the contract by piecework, station work, or by subcontract. 23 CFR 633.102(d).

3. A breach of any of the stipulations contained in these Required Contract Provisions may be sufficient grounds for withholding of progress payments, withholding of final payment, termination of the contract, suspension / debarment or any other action determined to be appropriate by the contracting agency and FHWA.

4. Selection of Labor: During the performance of this contract, the contractor shall not use convict labor for any purpose within the limits of a construction project on a Federal-aid highway unless it is labor performed by convicts who are on parole, supervised release, or probation. 23 U.S.C. 114(b). The term Federal-aid highway does not include roadways functionally classified as local roads or rural minor collectors. 23 U.S.C. 101(a).

**II. NONDISCRIMINATION (23 CFR 230.107(a); 23 CFR Part 230, Subpart A, Appendix A; EO 11246)**

The provisions of this section related to 23 CFR Part 230, Subpart A, Appendix A are applicable to all Federal-aid construction contracts and to all related construction subcontracts of \$10,000 or more. The provisions of 23 CFR Part 230 are not applicable to material supply, engineering, or architectural service contracts.

In addition, the contractor and all subcontractors must comply with the following policies: Executive Order 11246, 41 CFR Part 60, 29 CFR Parts 1625-1627, 23 U.S.C. 140, Section 504 of the Rehabilitation Act of 1973, as amended (29 U.S.C. 794), Title VI of the Civil Rights Act of 1964, as amended (42 U.S.C. 2000d et seq.), and related regulations including 49 CFR Parts 21, 26, and 27; and 23 CFR Parts 200, 230, and 633.

The contractor and all subcontractors must comply with: the requirements of the Equal Opportunity Clause in 41 CFR 60-1.4(b) and, for all construction contracts exceeding \$10,000, the Standard Federal Equal Employment Opportunity Construction Contract Specifications in 41 CFR 60-4.3.

Note: The U.S. Department of Labor has exclusive authority to determine compliance with Executive Order 11246 and the policies of the Secretary of Labor including 41 CFR Part 60, and 29 CFR Parts 1625-1627. The contracting agency and the FHWA have the authority and the responsibility to ensure compliance with 23 U.S.C. 140, Section 504 of the Rehabilitation Act of 1973, as amended (29 U.S.C. 794), and Title VI of the Civil Rights Act of 1964, as amended (42 U.S.C. 2000d et seq.), and related regulations including 49 CFR Parts 21, 26, and 27; and 23 CFR Parts 200, 230, and 633.

The following provision is adopted from 23 CFR Part 230, Subpart A, Appendix A, with appropriate revisions to conform to the U.S. Department of Labor (US DOL) and FHWA requirements.

**1. Equal Employment Opportunity:** Equal Employment Opportunity (EEO) requirements not to discriminate and to take affirmative action to assure equal opportunity as set forth under laws, executive orders, rules, regulations (see 28 CFR Part 35, 29 CFR Part 1630, 29 CFR Parts 1625-1627, 41 CFR Part 60 and 49 CFR Part 27) and orders of the Secretary of Labor as modified by the provisions prescribed herein, and imposed pursuant to 23 U.S.C. 140, shall constitute the EEO and specific affirmative action standards for the contractor's project activities under this contract. The provisions of the Americans with Disabilities Act of 1990 (42 U.S.C. 12101 et seq.) set forth under 28 CFR Part 35 and 29 CFR Part 1630 are incorporated by reference in this contract. In the execution of this contract, the contractor agrees to comply with the following minimum specific requirement activities of EEO:

a. The contractor will work with the contracting agency and the Federal Government to ensure that it has made every good faith effort to provide equal opportunity with respect to all of its terms and conditions of employment and in their review of activities under the contract. 23 CFR 230.409 (g)(4) & (5).

b. The contractor will accept as its operating policy the following statement:

"It is the policy of this Company to assure that applicants are employed, and that employees are treated during employment, without regard to their race, religion, sex, sexual orientation, gender identity, color, national origin, age or disability. Such action shall include: employment, upgrading, demotion, or transfer; recruitment or recruitment advertising; layoff or termination; rates of pay or other forms of compensation; and selection for training, including apprenticeship, pre-apprenticeship, and/or on-the-job training."

**2. EEO Officer:** The contractor will designate and make known to the contracting officers an EEO Officer who will have the responsibility for and must be capable of effectively administering and promoting an active EEO program and who must be assigned adequate authority and responsibility to do so.

**3. Dissemination of Policy:** All members of the contractor's staff who are authorized to hire, supervise, promote, and discharge employees, or who recommend such action or are substantially involved in such action, will be made fully cognizant of and will implement the contractor's EEO policy and contractual responsibilities to provide EEO in each grade and classification of employment. To ensure that the above agreement will be met, the following actions will be taken as a minimum:

a. Periodic meetings of supervisory and personnel office employees will be conducted before the start of work and then not less often than once every six months, at which time the contractor's EEO policy and its implementation will be reviewed and explained. The meetings will be conducted by the EEO Officer or other knowledgeable company official.

b. All new supervisory or personnel office employees will be given a thorough indoctrination by the EEO Officer, covering all major aspects of the contractor's EEO obligations within thirty days following their reporting for duty with the contractor.

c. All personnel who are engaged in direct recruitment for the project will be instructed by the EEO Officer in the contractor's procedures for locating and hiring minorities and women.

d. Notices and posters setting forth the contractor's EEO policy will be placed in areas readily accessible to employees, applicants for employment and potential employees.

e. The contractor's EEO policy and the procedures to implement such policy will be brought to the attention of employees by means of meetings, employee handbooks, or other appropriate means.

**4. Recruitment:** When advertising for employees, the contractor will include in all advertisements for employees the notation: "An Equal Opportunity Employer." All such advertisements will be placed in publications having a large circulation among minorities and women in the area from which the project work force would normally be derived.

a. The contractor will, unless precluded by a valid bargaining agreement, conduct systematic and direct recruitment through public and private employee referral sources likely to yield qualified minorities and women. To meet this requirement, the contractor will identify sources of potential minority group employees and establish with such identified sources procedures whereby minority and women applicants may be referred to the contractor for employment consideration.

b. In the event the contractor has a valid bargaining agreement providing for exclusive hiring hall referrals, the contractor is expected to observe the provisions of that agreement to the extent that the system meets the contractor's compliance with EEO contract provisions. Where implementation of such an agreement has the effect of discriminating against minorities or women, or obligates the contractor to do the same, such implementation violates Federal nondiscrimination provisions.

c. The contractor will encourage its present employees to refer minorities and women as applicants for employment. Information and procedures with regard to referring such applicants will be discussed with employees.

**5. Personnel Actions:** Wages, working conditions, and employee benefits shall be established and administered, and personnel actions of every type, including hiring, upgrading, promotion, transfer, demotion, layoff, and termination, shall be taken without regard to race, color, religion, sex, sexual orientation, gender identity, national origin, age or disability. The following procedures shall be followed:

a. The contractor will conduct periodic inspections of project sites to ensure that working conditions and employee facilities do not indicate discriminatory treatment of project site personnel.

b. The contractor will periodically evaluate the spread of wages paid within each classification to determine any evidence of discriminatory wage practices.

c. The contractor will periodically review selected personnel actions in depth to determine whether there is evidence of discrimination. Where evidence is found, the contractor will promptly take corrective action. If the review indicates that the discrimination may extend beyond the actions reviewed, such corrective action shall include all affected persons.

d. The contractor will promptly investigate all complaints of alleged discrimination made to the contractor in connection with its obligations under this contract, will attempt to resolve such complaints, and will take appropriate corrective action

within a reasonable time. If the investigation indicates that the discrimination may affect persons other than the complainant, such corrective action shall include such other persons. Upon completion of each investigation, the contractor will inform every complainant of all of their avenues of appeal.

#### **6. Training and Promotion:**

a. The contractor will assist in locating, qualifying, and increasing the skills of minorities and women who are applicants for employment or current employees. Such efforts should be aimed at developing full journey level status employees in the type of trade or job classification involved.

b. Consistent with the contractor's work force requirements and as permissible under Federal and State regulations, the contractor shall make full use of training programs (i.e., apprenticeship and on-the-job training programs for the geographical area of contract performance). In the event a special provision for training is provided under this contract, this subparagraph will be superseded as indicated in the special provision. The contracting agency may reserve training positions for persons who receive welfare assistance in accordance with 23 U.S.C. 140(a).

c. The contractor will advise employees and applicants for employment of available training programs and entrance requirements for each.

d. The contractor will periodically review the training and promotion potential of employees who are minorities and women and will encourage eligible employees to apply for such training and promotion.

**7. Unions:** If the contractor relies in whole or in part upon unions as a source of employees, the contractor will use good faith efforts to obtain the cooperation of such unions to increase opportunities for minorities and women. 23 CFR 230.409. Actions by the contractor, either directly or through a contractor's association acting as agent, will include the procedures set forth below:

a. The contractor will use good faith efforts to develop, in cooperation with the unions, joint training programs aimed toward qualifying more minorities and women for membership in the unions and increasing the skills of minorities and women so that they may qualify for higher paying employment.

b. The contractor will use good faith efforts to incorporate an EEO clause into each union agreement to the end that such union will be contractually bound to refer applicants without regard to their race, color, religion, sex, sexual orientation, gender identity, national origin, age, or disability.

c. The contractor is to obtain information as to the referral practices and policies of the labor union except that to the extent such information is within the exclusive possession of the labor union and such labor union refuses to furnish such information to the contractor, the contractor shall so certify to the contracting agency and shall set forth what efforts have been made to obtain such information.

d. In the event the union is unable to provide the contractor with a reasonable flow of referrals within the time limit set forth in the collective bargaining agreement, the contractor will, through independent recruitment efforts, fill the employment vacancies without regard to race, color, religion, sex, sexual orientation, gender identity, national origin, age, or disability; making full efforts to obtain qualified and/or qualifiable minorities and women. The failure of a union to provide

sufficient referrals (even though it is obligated to provide exclusive referrals under the terms of a collective bargaining agreement) does not relieve the contractor from the requirements of this paragraph. In the event the union referral practice prevents the contractor from meeting the obligations pursuant to Executive Order 11246, as amended, and these special provisions, such contractor shall immediately notify the contracting agency.

**8. Reasonable Accommodation for Applicants / Employees with Disabilities:** The contractor must be familiar with the requirements for and comply with the Americans with Disabilities Act and all rules and regulations established thereunder. Employers must provide reasonable accommodation in all employment activities unless to do so would cause an undue hardship.

**9. Selection of Subcontractors, Procurement of Materials and Leasing of Equipment:** The contractor shall not discriminate on the grounds of race, color, religion, sex, sexual orientation, gender identity, national origin, age, or disability in the selection and retention of subcontractors, including procurement of materials and leases of equipment. The contractor shall take all necessary and reasonable steps to ensure nondiscrimination in the administration of this contract.

a. The contractor shall notify all potential subcontractors, suppliers, and lessors of their EEO obligations under this contract.

b. The contractor will use good faith efforts to ensure subcontractor compliance with their EEO obligations.

#### **10. Assurances Required:**

a. The requirements of 49 CFR Part 26 and the State DOT's FHWA-approved Disadvantaged Business Enterprise (DBE) program are incorporated by reference.

b. The contractor, subrecipient or subcontractor shall not discriminate on the basis of race, color, national origin, or sex in the performance of this contract. The contractor shall carry out applicable requirements of 49 CFR part 26 in the award and administration of DOT-assisted contracts. Failure by the contractor to carry out these requirements is a material breach of this contract, which may result in the termination of this contract or such other remedy as the recipient deems appropriate, which may include, but is not limited to:

- (1) Withholding monthly progress payments;
- (2) Assessing sanctions;
- (3) Liquidated damages; and/or
- (4) Disqualifying the contractor from future bidding as non-responsible.

c. The Title VI and nondiscrimination provisions of U.S. DOT Order 1050.2A at Appendixes A and E are incorporated by reference. 49 CFR Part 21.

**11. Records and Reports:** The contractor shall keep such records as necessary to document compliance with the EEO requirements. Such records shall be retained for a period of three years following the date of the final payment to the contractor for all contract work and shall be available at reasonable times and places for inspection by authorized representatives of the contracting agency and the FHWA.

a. The records kept by the contractor shall document the following:

(1) The number and work hours of minority and non-minority group members and women employed in each work classification on the project;

(2) The progress and efforts being made in cooperation with unions, when applicable, to increase employment opportunities for minorities and women; and

(3) The progress and efforts being made in locating, hiring, training, qualifying, and upgrading minorities and women.

b. The contractors and subcontractors will submit an annual report to the contracting agency each July for the duration of the project indicating the number of minority, women, and non-minority group employees currently engaged in each work classification required by the contract work. This information is to be reported on [Form FHWA-1391](#). The staffing data should represent the project work force on board in all or any part of the last payroll period preceding the end of July. If on-the-job training is being required by special provision, the contractor will be required to collect and report training data. The employment data should reflect the work force on board during all or any part of the last payroll period preceding the end of July.

### III. NONSEGREGATED FACILITIES

This provision is applicable to all Federal-aid construction contracts and to all related construction subcontracts of more than \$10,000. 41 CFR 60-1.5.

As prescribed by 41 CFR 60-1.8, the contractor must ensure that facilities provided for employees are provided in such a manner that segregation on the basis of race, color, religion, sex, sexual orientation, gender identity, or national origin cannot result. The contractor may neither require such segregated use by written or oral policies nor tolerate such use by employee custom. The contractor's obligation extends further to ensure that its employees are not assigned to perform their services at any location under the contractor's control where the facilities are segregated. The term "facilities" includes waiting rooms, work areas, restaurants and other eating areas, time clocks, restrooms, washrooms, locker rooms and other storage or dressing areas, parking lots, drinking fountains, recreation or entertainment areas, transportation, and housing provided for employees. The contractor shall provide separate or single-user restrooms and necessary dressing or sleeping areas to assure privacy between sexes.

### IV. DAVIS-BACON AND RELATED ACT PROVISIONS

This section is applicable to all Federal-aid construction projects exceeding \$2,000 and to all related subcontracts and lower-tier subcontracts (regardless of subcontract size), in accordance with 29 CFR 5.5. The requirements apply to all projects located within the right-of-way of a roadway that is functionally classified as Federal-aid highway. 23 U.S.C. 113. This excludes roadways functionally classified as local roads or rural minor collectors, which are exempt. 23 U.S.C. 101. Where applicable law requires that projects be treated as a project on a Federal-aid highway, the provisions of this subpart will apply regardless of the location of the project. Examples include: Surface Transportation Block Grant Program projects funded under 23 U.S.C. 133 [excluding recreational trails projects], the Nationally Significant Freight and Highway

Projects funded under 23 U.S.C. 117, and National Highway Freight Program projects funded under 23 U.S.C. 167.

The following provisions are from the U.S. Department of Labor regulations in 29 CFR 5.5 "Contract provisions and related matters" with minor revisions to conform to the FHWA-1273 format and FHWA program requirements.

#### 1. Minimum wages (29 CFR 5.5)

a. All laborers and mechanics employed or working upon the site of the work, will be paid unconditionally and not less often than once a week, and without subsequent deduction or rebate on any account (except such payroll deductions as are permitted by regulations issued by the Secretary of Labor under the Copeland Act (29 CFR part 3)), the full amount of wages and bona fide fringe benefits (or cash equivalents thereof) due at time of payment computed at rates not less than those contained in the wage determination of the Secretary of Labor which is attached hereto and made a part hereof, regardless of any contractual relationship which may be alleged to exist between the contractor and such laborers and mechanics.

Contributions made or costs reasonably anticipated for bona fide fringe benefits under section 1(b)(2) of the Davis-Bacon Act on behalf of laborers or mechanics are considered wages paid to such laborers or mechanics, subject to the provisions of paragraph 1.d. of this section; also, regular contributions made or costs incurred for more than a weekly period (but not less often than quarterly) under plans, funds, or programs which cover the particular weekly period, are deemed to be constructively made or incurred during such weekly period. Such laborers and mechanics shall be paid the appropriate wage rate and fringe benefits on the wage determination for the classification of work actually performed, without regard to skill, except as provided in 29 CFR 5.5(a)(4). Laborers or mechanics performing work in more than one classification may be compensated at the rate specified for each classification for the time actually worked therein: Provided, That the employer's payroll records accurately set forth the time spent in each classification in which work is performed. The wage determination (including any additional classification and wage rates conformed under paragraph 1.b. of this section) and the Davis-Bacon poster (WH-1321) shall be posted at all times by the contractor and its subcontractors at the site of the work in a prominent and accessible place where it can be easily seen by the workers.

b.(1) The contracting officer shall require that any class of laborers or mechanics, including helpers, which is not listed in the wage determination and which is to be employed under the contract shall be classified in conformance with the wage determination. The contracting officer shall approve an additional classification and wage rate and fringe benefits therefore only when the following criteria have been met:

(i) The work to be performed by the classification requested is not performed by a classification in the wage determination; and

(ii) The classification is utilized in the area by the construction industry; and



(iii) The proposed wage rate, including any bona fide fringe benefits, bears a reasonable relationship to the wage rates contained in the wage determination.

(2) If the contractor and the laborers and mechanics to be employed in the classification (if known), or their representatives, and the contracting officer agree on the classification and wage rate (including the amount designated for fringe benefits where appropriate), a report of the action taken shall be sent by the contracting officer to the Administrator of the Wage and Hour Division, U.S. Department of Labor, Washington, DC 20210. The Administrator, or an authorized representative, will approve, modify, or disapprove every additional classification action within 30 days of receipt and so advise the contracting officer or will notify the contracting officer within the 30-day period that additional time is necessary.

(3) In the event the contractor, the laborers or mechanics to be employed in the classification or their representatives, and the contracting officer do not agree on the proposed classification and wage rate (including the amount designated for fringe benefits, where appropriate), the contracting officer shall refer the questions, including the views of all interested parties and the recommendation of the contracting officer, to the Administrator for determination. The Administrator, or an authorized representative, will issue a determination within 30 days of receipt and so advise the contracting officer or will notify the contracting officer within the 30-day period that additional time is necessary.

(4) The wage rate (including fringe benefits where appropriate) determined pursuant to paragraphs 1.b.(2) or 1.b.(3) of this section, shall be paid to all workers performing work in the classification under this contract from the first day on which work is performed in the classification.

c. Whenever the minimum wage rate prescribed in the contract for a class of laborers or mechanics includes a fringe benefit which is not expressed as an hourly rate, the contractor shall either pay the benefit as stated in the wage determination or shall pay another bona fide fringe benefit or an hourly cash equivalent thereof.

d. If the contractor does not make payments to a trustee or other third person, the contractor may consider as part of the wages of any laborer or mechanic the amount of any costs reasonably anticipated in providing bona fide fringe benefits under a plan or program, Provided, That the Secretary of Labor has found, upon the written request of the contractor, that the applicable standards of the Davis-Bacon Act have been met. The Secretary of Labor may require the contractor to set aside in a separate account assets for the meeting of obligations under the plan or program.

## **2. Withholding (29 CFR 5.5)**

The contracting agency shall upon its own action or upon written request of an authorized representative of the Department of Labor, withhold or cause to be withheld from the contractor under this contract, or any other Federal contract with the same prime contractor, or any other federally-assisted contract subject to Davis-Bacon prevailing wage requirements, which is held by the same prime contractor, so much of the accrued payments or advances as may be considered necessary to pay laborers and mechanics,

including apprentices, trainees, and helpers, employed by the contractor or any subcontractor the full amount of wages required by the contract. In the event of failure to pay any laborer or mechanic, including any apprentice, trainee, or helper, employed or working on the site of the work, all or part of the wages required by the contract, the contracting agency may, after written notice to the contractor, take such action as may be necessary to cause the suspension of any further payment, advance, or guarantee of funds until such violations have ceased.

## **3. Payrolls and basic records (29 CFR 5.5)**

a. Payrolls and basic records relating thereto shall be maintained by the contractor during the course of the work and preserved for a period of three years thereafter for all laborers and mechanics working at the site of the work. Such records shall contain the name, address, and social security number of each such worker, his or her correct classification, hourly rates of wages paid (including rates of contributions or costs anticipated for bona fide fringe benefits or cash equivalents thereof of the types described in section 1(b)(2)(B) of the Davis-Bacon Act), daily and weekly number of hours worked, deductions made and actual wages paid. Whenever the Secretary of Labor has found under 29 CFR 5.5(a)(1)(iv) that the wages of any laborer or mechanic include the amount of any costs reasonably anticipated in providing benefits under a plan or program described in section 1(b)(2)(B) of the Davis-Bacon Act, the contractor shall maintain records which show that the commitment to provide such benefits is enforceable, that the plan or program is financially responsible, and that the plan or program has been communicated in writing to the laborers or mechanics affected, and records which show the costs anticipated or the actual cost incurred in providing such benefits. Contractors employing apprentices or trainees under approved programs shall maintain written evidence of the registration of apprenticeship programs and certification of trainee programs, the registration of the apprentices and trainees, and the ratios and wage rates prescribed in the applicable programs.

b.(1) The contractor shall submit weekly for each week in which any contract work is performed a copy of all payrolls to the contracting agency. The payrolls submitted shall set out accurately and completely all of the information required to be maintained under 29 CFR 5.5(a)(3)(i), except that full social security numbers and home addresses shall not be included on weekly transmittals. Instead the payrolls shall only need to include an individually identifying number for each employee (e.g., the last four digits of the employee's social security number). The required weekly payroll information may be submitted in any form desired. Optional Form WH-347 is available for this purpose from the Wage and Hour Division Web site. The prime contractor is responsible for the submission of copies of payrolls by all subcontractors. Contractors and subcontractors shall maintain the full social security number and current address of each covered worker, and shall provide them upon request to the contracting agency for transmission to the State DOT, the FHWA or the Wage and Hour Division of the Department of Labor for purposes of an investigation or audit of compliance with prevailing wage requirements. It is not a violation of this section for a prime contractor to require a subcontractor to provide addresses and social security numbers to the prime contractor for its own records, without weekly submission to the contracting agency.

(2) Each payroll submitted shall be accompanied by a "Statement of Compliance," signed by the contractor or

subcontractor or his or her agent who pays or supervises the payment of the persons employed under the contract and shall certify the following:

(i) That the payroll for the payroll period contains the information required to be provided under 29 CFR 5.5(a)(3)(ii), the appropriate information is being maintained under 29 CFR 5.5(a)(3)(i), and that such information is correct and complete;

(ii) That each laborer or mechanic (including each helper, apprentice, and trainee) employed on the contract during the payroll period has been paid the full weekly wages earned, without rebate, either directly or indirectly, and that no deductions have been made either directly or indirectly from the full wages earned, other than permissible deductions as set forth in 29 CFR part 3;

(iii) That each laborer or mechanic has been paid not less than the applicable wage rates and fringe benefits or cash equivalents for the classification of work performed, as specified in the applicable wage determination incorporated into the contract.

(3) The weekly submission of a properly executed certification set forth on the reverse side of Optional Form WH-347 shall satisfy the requirement for submission of the "Statement of Compliance" required by paragraph 3.b.(2) of this section.

(4) The falsification of any of the above certifications may subject the contractor or subcontractor to civil or criminal prosecution under 18 U.S.C. 1001 and 31 U.S.C. 231.

c. The contractor or subcontractor shall make the records required under paragraph 3.a. of this section available for inspection, copying, or transcription by authorized representatives of the contracting agency, the State DOT, the FHWA, or the Department of Labor, and shall permit such representatives to interview employees during working hours on the job. If the contractor or subcontractor fails to submit the required records or to make them available, the FHWA may, after written notice to the contractor, the contracting agency or the State DOT, take such action as may be necessary to cause the suspension of any further payment, advance, or guarantee of funds. Furthermore, failure to submit the required records upon request or to make such records available may be grounds for debarment action pursuant to 29 CFR 5.12.

#### 4. Apprentices and trainees (29 CFR 5.5)

##### a. Apprentices (programs of the USDOL).

Apprentices will be permitted to work at less than the predetermined rate for the work they performed when they are employed pursuant to and individually registered in a bona fide apprenticeship program registered with the U.S. Department of Labor, Employment and Training Administration, Office of Apprenticeship Training, Employer and Labor Services, or with a State Apprenticeship Agency recognized by the Office, or if a person is employed in his or her first 90 days of probationary employment as an apprentice in such an apprenticeship program, who is not individually registered in the program, but who has been certified by the Office of Apprenticeship Training, Employer and Labor Services or a State

Apprenticeship Agency (where appropriate) to be eligible for probationary employment as an apprentice.

The allowable ratio of apprentices to journeymen on the job site in any craft classification shall not be greater than the ratio permitted to the contractor as to the entire work force under the registered program. Any worker listed on a payroll at an apprentice wage rate, who is not registered or otherwise employed as stated above, shall be paid not less than the applicable wage rate on the wage determination for the classification of work actually performed. In addition, any apprentice performing work on the job site in excess of the ratio permitted under the registered program shall be paid not less than the applicable wage rate on the wage determination for the work actually performed. Where a contractor is performing construction on a project in a locality other than that in which its program is registered, the ratios and wage rates (expressed in percentages of the journeyman's hourly rate) specified in the contractor's or subcontractor's registered program shall be observed.

Every apprentice must be paid at not less than the rate specified in the registered program for the apprentice's level of progress, expressed as a percentage of the journeymen hourly rate specified in the applicable wage determination. Apprentices shall be paid fringe benefits in accordance with the provisions of the apprenticeship program. If the apprenticeship program does not specify fringe benefits, apprentices must be paid the full amount of fringe benefits listed on the wage determination for the applicable classification. If the Administrator determines that a different practice prevails for the applicable apprentice classification, fringes shall be paid in accordance with that determination.

In the event the Office of Apprenticeship Training, Employer and Labor Services, or a State Apprenticeship Agency recognized by the Office, withdraws approval of an apprenticeship program, the contractor will no longer be permitted to utilize apprentices at less than the applicable predetermined rate for the work performed until an acceptable program is approved.

##### b. Trainees (programs of the USDOL).

Except as provided in 29 CFR 5.16, trainees will not be permitted to work at less than the predetermined rate for the work performed unless they are employed pursuant to and individually registered in a program which has received prior approval, evidenced by formal certification by the U.S. Department of Labor, Employment and Training Administration.

The ratio of trainees to journeymen on the job site shall not be greater than permitted under the plan approved by the Employment and Training Administration.

Every trainee must be paid at not less than the rate specified in the approved program for the trainee's level of progress, expressed as a percentage of the journeyman hourly rate specified in the applicable wage determination. Trainees shall be paid fringe benefits in accordance with the provisions of the trainee program. If the trainee program does not mention fringe benefits, trainees shall be paid the full amount of fringe benefits listed on the wage determination unless the Administrator of the Wage and Hour Division determines that there is an apprenticeship program associated with the

corresponding journeyman wage rate on the wage determination which provides for less than full fringe benefits for apprentices. Any employee listed on the payroll at a trainee rate who is not registered and participating in a training plan approved by the Employment and Training Administration shall be paid not less than the applicable wage rate on the wage determination for the classification of work actually performed. In addition, any trainee performing work on the job site in excess of the ratio permitted under the registered program shall be paid not less than the applicable wage rate on the wage determination for the work actually performed.

In the event the Employment and Training Administration withdraws approval of a training program, the contractor will no longer be permitted to utilize trainees at less than the applicable predetermined rate for the work performed until an acceptable program is approved.

c. Equal employment opportunity. The utilization of apprentices, trainees and journeymen under this part shall be in conformity with the equal employment opportunity requirements of Executive Order 11246, as amended, and 29 CFR part 30.

d. Apprentices and Trainees (programs of the U.S. DOT).

Apprentices and trainees working under apprenticeship and skill training programs which have been certified by the Secretary of Transportation as promoting EEO in connection with Federal-aid highway construction programs are not subject to the requirements of paragraph 4 of this Section IV. 23 CFR 230.111(e)(2). The straight time hourly wage rates for apprentices and trainees under such programs will be established by the particular programs. The ratio of apprentices and trainees to journeymen shall not be greater than permitted by the terms of the particular program.

**5. Compliance with Copeland Act requirements.** The contractor shall comply with the requirements of 29 CFR part 3, which are incorporated by reference in this contract as provided in 29 CFR 5.5.

**6. Subcontracts.** The contractor or subcontractor shall insert Form FHWA-1273 in any subcontracts and also require the subcontractors to include Form FHWA-1273 in any lower tier subcontracts. The prime contractor shall be responsible for the compliance by any subcontractor or lower tier subcontractor with all the contract clauses in 29 CFR 5.5.

**7. Contract termination: debarment.** A breach of the contract clauses in 29 CFR 5.5 may be grounds for termination of the contract, and for debarment as a contractor and a subcontractor as provided in 29 CFR 5.12.

**8. Compliance with Davis-Bacon and Related Act requirements.** All rulings and interpretations of the Davis-Bacon and Related Acts contained in 29 CFR parts 1, 3, and 5 are herein incorporated by reference in this contract as provided in 29 CFR 5.5.

**9. Disputes concerning labor standards.** As provided in 29 CFR 5.5, disputes arising out of the labor standards provisions of this contract shall not be subject to the general disputes clause of this contract. Such disputes shall be resolved in accordance with the procedures of the Department of Labor

set forth in 29 CFR parts 5, 6, and 7. Disputes within the meaning of this clause include disputes between the contractor (or any of its subcontractors) and the contracting agency, the U.S. Department of Labor, or the employees or their representatives.

#### **10. Certification of eligibility (29 CFR 5.5)**

a. By entering into this contract, the contractor certifies that neither it (nor he or she) nor any person or firm who has an interest in the contractor's firm is a person or firm ineligible to be awarded Government contracts by virtue of section 3(a) of the Davis-Bacon Act or 29 CFR 5.12(a)(1).

b. No part of this contract shall be subcontracted to any person or firm ineligible for award of a Government contract by virtue of section 3(a) of the Davis-Bacon Act or 29 CFR 5.12(a)(1).

c. The penalty for making false statements is prescribed in the U.S. Criminal Code, 18 U.S.C. 1001.

#### **V. CONTRACT WORK HOURS AND SAFETY STANDARDS ACT**

Pursuant to 29 CFR 5.5(b), the following clauses apply to any Federal-aid construction contract in an amount in excess of \$100,000 and subject to the overtime provisions of the Contract Work Hours and Safety Standards Act. These clauses shall be inserted in addition to the clauses required by 29 CFR 5.5(a) or 29 CFR 4.6. As used in this paragraph, the terms laborers and mechanics include watchmen and guards.

**1. Overtime requirements.** No contractor or subcontractor contracting for any part of the contract work which may require or involve the employment of laborers or mechanics shall require or permit any such laborer or mechanic in any workweek in which he or she is employed on such work to work in excess of forty hours in such workweek unless such laborer or mechanic receives compensation at a rate not less than one and one-half times the basic rate of pay for all hours worked in excess of forty hours in such workweek. 29 CFR 5.5.

**2. Violation; liability for unpaid wages; liquidated damages.** In the event of any violation of the clause set forth in paragraph 1 of this section, the contractor and any subcontractor responsible therefor shall be liable for the unpaid wages. In addition, such contractor and subcontractor shall be liable to the United States (in the case of work done under contract for the District of Columbia or a territory, to such District or to such territory), for liquidated damages. Such liquidated damages shall be computed with respect to each individual laborer or mechanic, including watchmen and guards, employed in violation of the clause set forth in paragraph 1 of this section, in the sum currently provided in 29 CFR 5.5(b)(2)\* for each calendar day on which such individual was required or permitted to work in excess of the standard workweek of forty hours without payment of the overtime wages required by the clause set forth in paragraph 1 of this section. 29 CFR 5.5.

\* \$27 as of January 23, 2019 (See 84 FR 213-01, 218) as may be adjusted annually by the Department of Labor; pursuant to the Federal Civil Penalties Inflation Adjustment Act of 1990).

### **3. Withholding for unpaid wages and liquidated damages.**

The FHWA or the contracting agency shall upon its own action or upon written request of an authorized representative of the Department of Labor withhold or cause to be withheld, from any moneys payable on account of work performed by the contractor or subcontractor under any such contract or any other Federal contract with the same prime contractor, or any other federally-assisted contract subject to the Contract Work Hours and Safety Standards Act, which is held by the same prime contractor, such sums as may be determined to be necessary to satisfy any liabilities of such contractor or subcontractor for unpaid wages and liquidated damages as provided in the clause set forth in paragraph 2 of this section. 29 CFR 5.5.

**4. Subcontracts.** The contractor or subcontractor shall insert in any subcontracts the clauses set forth in paragraphs 1 through 4 of this section and also a clause requiring the subcontractors to include these clauses in any lower tier subcontracts. The prime contractor shall be responsible for compliance by any subcontractor or lower tier subcontractor with the clauses set forth in paragraphs 1 through 4 of this section. 29 CFR 5.5.

## **VI. SUBLETTING OR ASSIGNING THE CONTRACT**

This provision is applicable to all Federal-aid construction contracts on the National Highway System pursuant to 23 CFR 635.116.

1. The contractor shall perform with its own organization contract work amounting to not less than 30 percent (or a greater percentage if specified elsewhere in the contract) of the total original contract price, excluding any specialty items designated by the contracting agency. Specialty items may be performed by subcontract and the amount of any such specialty items performed may be deducted from the total original contract price before computing the amount of work required to be performed by the contractor's own organization (23 CFR 635.116).

a. The term "perform work with its own organization" in paragraph 1 of Section VI refers to workers employed or leased by the prime contractor, and equipment owned or rented by the prime contractor, with or without operators. Such term does not include employees or equipment of a subcontractor or lower tier subcontractor, agents of the prime contractor, or any other assignees. The term may include payments for the costs of hiring leased employees from an employee leasing firm meeting all relevant Federal and State regulatory requirements. Leased employees may only be included in this term if the prime contractor meets all of the following conditions: (based on longstanding interpretation)

- (1) the prime contractor maintains control over the supervision of the day-to-day activities of the leased employees;
- (2) the prime contractor remains responsible for the quality of the work of the leased employees;
- (3) the prime contractor retains all power to accept or exclude individual employees from work on the project; and
- (4) the prime contractor remains ultimately responsible for the payment of predetermined minimum wages, the submission of payrolls, statements of compliance and all other Federal regulatory requirements.

b. "Specialty Items" shall be construed to be limited to work that requires highly specialized knowledge, abilities, or

equipment not ordinarily available in the type of contracting organizations qualified and expected to bid or propose on the contract as a whole and in general are to be limited to minor components of the overall contract. 23 CFR 635.102.

2. Pursuant to 23 CFR 635.116(a), the contract amount upon which the requirements set forth in paragraph (1) of Section VI is computed includes the cost of material and manufactured products which are to be purchased or produced by the contractor under the contract provisions.

3. Pursuant to 23 CFR 635.116(c), the contractor shall furnish (a) a competent superintendent or supervisor who is employed by the firm, has full authority to direct performance of the work in accordance with the contract requirements, and is in charge of all construction operations (regardless of who performs the work) and (b) such other of its own organizational resources (supervision, management, and engineering services) as the contracting officer determines is necessary to assure the performance of the contract.

4. No portion of the contract shall be sublet, assigned or otherwise disposed of except with the written consent of the contracting officer, or authorized representative, and such consent when given shall not be construed to relieve the contractor of any responsibility for the fulfillment of the contract. Written consent will be given only after the contracting agency has assured that each subcontract is evidenced in writing and that it contains all pertinent provisions and requirements of the prime contract. (based on longstanding interpretation of 23 CFR 635.116).

5. The 30-percent self-performance requirement of paragraph (1) is not applicable to design-build contracts; however, contracting agencies may establish their own self-performance requirements. 23 CFR 635.116(d).

## **VII. SAFETY: ACCIDENT PREVENTION**

This provision is applicable to all Federal-aid construction contracts and to all related subcontracts.

1. In the performance of this contract the contractor shall comply with all applicable Federal, State, and local laws governing safety, health, and sanitation (23 CFR Part 635). The contractor shall provide all safeguards, safety devices and protective equipment and take any other needed actions as it determines, or as the contracting officer may determine, to be reasonably necessary to protect the life and health of employees on the job and the safety of the public and to protect property in connection with the performance of the work covered by the contract. 23 CFR 635.108.

2. It is a condition of this contract, and shall be made a condition of each subcontract, which the contractor enters into pursuant to this contract, that the contractor and any subcontractor shall not permit any employee, in performance of the contract, to work in surroundings or under conditions which are unsanitary, hazardous or dangerous to his/her health or safety, as determined under construction safety and health standards (29 CFR Part 1926) promulgated by the Secretary of Labor, in accordance with Section 107 of the Contract Work Hours and Safety Standards Act (40 U.S.C. 3704). 29 CFR 1926.10.

3. Pursuant to 29 CFR 1926.3, it is a condition of this contract that the Secretary of Labor or authorized representative thereof, shall have right of entry to any site of contract performance to inspect or investigate the matter of compliance

with the construction safety and health standards and to carry out the duties of the Secretary under Section 107 of the Contract Work Hours and Safety Standards Act (40 U.S.C. 3704).

### **VIII. FALSE STATEMENTS CONCERNING HIGHWAY PROJECTS**

This provision is applicable to all Federal-aid construction contracts and to all related subcontracts.

In order to assure high quality and durable construction in conformity with approved plans and specifications and a high degree of reliability on statements and representations made by engineers, contractors, suppliers, and workers on Federal-aid highway projects, it is essential that all persons concerned with the project perform their functions as carefully, thoroughly, and honestly as possible. Willful falsification, distortion, or misrepresentation with respect to any facts related to the project is a violation of Federal law. To prevent any misunderstanding regarding the seriousness of these and similar acts, Form FHWA-1022 shall be posted on each Federal-aid highway project (23 CFR Part 635) in one or more places where it is readily available to all persons concerned with the project:

18 U.S.C. 1020 reads as follows:

"Whoever, being an officer, agent, or employee of the United States, or of any State or Territory, or whoever, whether a person, association, firm, or corporation, knowingly makes any false statement, false representation, or false report as to the character, quality, quantity, or cost of the material used or to be used, or the quantity or quality of the work performed or to be performed, or the cost thereof in connection with the submission of plans, maps, specifications, contracts, or costs of construction on any highway or related project submitted for approval to the Secretary of Transportation; or

Whoever knowingly makes any false statement, false representation, false report or false claim with respect to the character, quality, quantity, or cost of any work performed or to be performed, or materials furnished or to be furnished, in connection with the construction of any highway or related project approved by the Secretary of Transportation; or

Whoever knowingly makes any false statement or false representation as to material fact in any statement, certificate, or report submitted pursuant to provisions of the Federal-aid Roads Act approved July 11, 1916, (39 Stat. 355), as amended and supplemented;

Shall be fined under this title or imprisoned not more than 5 years or both."

### **IX. IMPLEMENTATION OF CLEAN AIR ACT AND FEDERAL WATER POLLUTION CONTROL ACT (42 U.S.C. 7606; 2 CFR 200.88; EO 11738)**

This provision is applicable to all Federal-aid construction contracts in excess of \$150,000 and to all related subcontracts. 48 CFR 2.101; 2 CFR 200.326.

By submission of this bid/proposal or the execution of this contract or subcontract, as appropriate, the bidder, proposer, Federal-aid construction contractor, subcontractor, supplier, or vendor agrees to comply with all applicable standards, orders

or regulations issued pursuant to the Clean Air Act (42 U.S.C. 7401-7671q) and the Federal Water Pollution Control Act, as amended (33 U.S.C. 1251-1387). Violations must be reported to the Federal Highway Administration and the Regional Office of the Environmental Protection Agency. 2 CFR Part 200, Appendix II.

The contractor agrees to include or cause to be included the requirements of this Section in every subcontract, and further agrees to take such action as the contracting agency may direct as a means of enforcing such requirements. 2 CFR 200.326.

### **X. CERTIFICATION REGARDING DEBARMENT, SUSPENSION, INELIGIBILITY AND VOLUNTARY EXCLUSION**

This provision is applicable to all Federal-aid construction contracts, design-build contracts, subcontracts, lower-tier subcontracts, purchase orders, lease agreements, consultant contracts or any other covered transaction requiring FHWA approval or that is estimated to cost \$25,000 or more – as defined in 2 CFR Parts 180 and 1200. 2 CFR 180.220 and 1200.220.

#### **1. Instructions for Certification – First Tier Participants:**

a. By signing and submitting this proposal, the prospective first tier participant is providing the certification set out below.

b. The inability of a person to provide the certification set out below will not necessarily result in denial of participation in this covered transaction. The prospective first tier participant shall submit an explanation of why it cannot provide the certification set out below. The certification or explanation will be considered in connection with the department or agency's determination whether to enter into this transaction. However, failure of the prospective first tier participant to furnish a certification or an explanation shall disqualify such a person from participation in this transaction. 2 CFR 180.320.

c. The certification in this clause is a material representation of fact upon which reliance was placed when the contracting agency determined to enter into this transaction. If it is later determined that the prospective participant knowingly rendered an erroneous certification, in addition to other remedies available to the Federal Government, the contracting agency may terminate this transaction for cause of default. 2 CFR 180.325.

d. The prospective first tier participant shall provide immediate written notice to the contracting agency to whom this proposal is submitted if any time the prospective first tier participant learns that its certification was erroneous when submitted or has become erroneous by reason of changed circumstances. 2 CFR 180.345 and 180.350.

e. The terms "covered transaction," "debarred," "suspended," "ineligible," "participant," "person," "principal," and "voluntarily excluded," as used in this clause, are defined in 2 CFR Parts 180, Subpart I, 180.900-180.1020, and 1200. "First Tier Covered Transactions" refers to any covered transaction between a recipient or subrecipient of Federal funds and a participant (such as the prime or general contract). "Lower Tier Covered Transactions" refers to any covered transaction under a First Tier Covered Transaction (such as subcontracts). "First Tier Participant" refers to the participant

who has entered into a covered transaction with a recipient or subrecipient of Federal funds (such as the prime or general contractor). "Lower Tier Participant" refers any participant who has entered into a covered transaction with a First Tier Participant or other Lower Tier Participants (such as subcontractors and suppliers).

f. The prospective first tier participant agrees by submitting this proposal that, should the proposed covered transaction be entered into, it shall not knowingly enter into any lower tier covered transaction with a person who is debarred, suspended, declared ineligible, or voluntarily excluded from participation in this covered transaction, unless authorized by the department or agency entering into this transaction. 2 CFR 180.330.

g. The prospective first tier participant further agrees by submitting this proposal that it will include the clause titled "Certification Regarding Debarment, Suspension, Ineligibility and Voluntary Exclusion-Lower Tier Covered Transactions," provided by the department or contracting agency, entering into this covered transaction, without modification, in all lower tier covered transactions and in all solicitations for lower tier covered transactions exceeding the \$25,000 threshold. 2 CFR 180.220 and 180.300.

h. A participant in a covered transaction may rely upon a certification of a prospective participant in a lower tier covered transaction that is not debarred, suspended, ineligible, or voluntarily excluded from the covered transaction, unless it knows that the certification is erroneous. 2 CFR 180.300; 180.320, and 180.325. A participant is responsible for ensuring that its principals are not suspended, debarred, or otherwise ineligible to participate in covered transactions. 2 CFR 180.335. To verify the eligibility of its principals, as well as the eligibility of any lower tier prospective participants, each participant may, but is not required to, check the System for Award Management website (<https://www.sam.gov/>). 2 CFR 180.300, 180.320, and 180.325.

i. Nothing contained in the foregoing shall be construed to require the establishment of a system of records in order to render in good faith the certification required by this clause. The knowledge and information of the prospective participant is not required to exceed that which is normally possessed by a prudent person in the ordinary course of business dealings.

j. Except for transactions authorized under paragraph (f) of these instructions, if a participant in a covered transaction knowingly enters into a lower tier covered transaction with a person who is suspended, debarred, ineligible, or voluntarily excluded from participation in this transaction, in addition to other remedies available to the Federal Government, the department or agency may terminate this transaction for cause or default. 2 CFR 180.325.

\*\*\*\*\*

## **2. Certification Regarding Debarment, Suspension, Ineligibility and Voluntary Exclusion – First Tier Participants:**

a. The prospective first tier participant certifies to the best of its knowledge and belief, that it and its principals:

(1) Are not presently debarred, suspended, proposed for debarment, declared ineligible, or voluntarily excluded from participating in covered transactions by any Federal department or agency, 2 CFR 180.335;.

(2) Have not within a three-year period preceding this proposal been convicted of or had a civil judgment rendered against them for commission of fraud or a criminal offense in connection with obtaining, attempting to obtain, or performing a public (Federal, State, or local) transaction or contract under a public transaction; violation of Federal or State antitrust statutes or commission of embezzlement, theft, forgery, bribery, falsification or destruction of records, making false statements, or receiving stolen property, 2 CFR 180.800;

(3) Are not presently indicted for or otherwise criminally or civilly charged by a governmental entity (Federal, State or local) with commission of any of the offenses enumerated in paragraph (a)(2) of this certification, 2 CFR 180.700 and 180.800; and

(4) Have not within a three-year period preceding this application/proposal had one or more public transactions (Federal, State or local) terminated for cause or default. 2 CFR 180.335(d).

(5) Are not a corporation that has been convicted of a felony violation under any Federal law within the two-year period preceding this proposal (USDOT Order 4200.6 implementing appropriations act requirements); and

(6) Are not a corporation with any unpaid Federal tax liability that has been assessed, for which all judicial and administrative remedies have been exhausted, or have lapsed, and that is not being paid in a timely manner pursuant to an agreement with the authority responsible for collecting the tax liability (USDOT Order 4200.6 implementing appropriations act requirements).

b. Where the prospective participant is unable to certify to any of the statements in this certification, such prospective participant should attach an explanation to this proposal. 2 CFR 180.335 and 180.340.

## **3. Instructions for Certification - Lower Tier Participants:**

(Applicable to all subcontracts, purchase orders, and other lower tier transactions requiring prior FHWA approval or estimated to cost \$25,000 or more - 2 CFR Parts 180 and 1200). 2 CFR 180.220 and 1200.220.

a. By signing and submitting this proposal, the prospective lower tier participant is providing the certification set out below.

b. The certification in this clause is a material representation of fact upon which reliance was placed when this transaction was entered into. If it is later determined that the prospective lower tier participant knowingly rendered an erroneous certification, in addition to other remedies available to the Federal Government, the department, or agency with which this transaction originated may pursue available remedies, including suspension and/or debarment.

c. The prospective lower tier participant shall provide immediate written notice to the person to which this proposal is submitted if at any time the prospective lower tier participant learns that its certification was erroneous by reason of changed circumstances. 2 CFR 180.365.

d. The terms "covered transaction," "debarred," "suspended," "ineligible," "participant," "person," "principal," and "voluntarily excluded," as used in this clause, are defined in 2 CFR Parts 180, Subpart I, 180.900 – 180.1020, and 1200. You may contact the person to which this proposal is

submitted for assistance in obtaining a copy of those regulations. "First Tier Covered Transactions" refers to any covered transaction between a recipient or subrecipient of Federal funds and a participant (such as the prime or general contractor). "Lower Tier Covered Transactions" refers to any covered transaction under a First Tier Covered Transaction (such as subcontracts). "First Tier Participant" refers to the participant who has entered into a covered transaction with a recipient or subrecipient of Federal funds (such as the prime or general contractor). "Lower Tier Participant" refers any participant who has entered into a covered transaction with a First Tier Participant or other Lower Tier Participants (such as subcontractors and suppliers).

e. The prospective lower tier participant agrees by submitting this proposal that, should the proposed covered transaction be entered into, it shall not knowingly enter into any lower tier covered transaction with a person who is debarred, suspended, declared ineligible, or voluntarily excluded from participation in this covered transaction, unless authorized by the department or agency with which this transaction originated. 2 CFR 1200.220 and 1200.332.

f. The prospective lower tier participant further agrees by submitting this proposal that it will include this clause titled "Certification Regarding Debarment, Suspension, Ineligibility and Voluntary Exclusion-Lower Tier Covered Transaction," without modification, in all lower tier covered transactions and in all solicitations for lower tier covered transactions exceeding the \$25,000 threshold. 2 CFR 180.220 and 1200.220.

g. A participant in a covered transaction may rely upon a certification of a prospective participant in a lower tier covered transaction that is not debarred, suspended, ineligible, or voluntarily excluded from the covered transaction, unless it knows that the certification is erroneous. A participant is responsible for ensuring that its principals are not suspended, debarred, or otherwise ineligible to participate in covered transactions. To verify the eligibility of its principals, as well as the eligibility of any lower tier prospective participants, each participant may, but is not required to, check the System for Award Management website (<https://www.sam.gov/>), which is compiled by the General Services Administration. 2 CFR 180.300, 180.320, 180.330, and 180.335.

h. Nothing contained in the foregoing shall be construed to require establishment of a system of records in order to render in good faith the certification required by this clause. The knowledge and information of participant is not required to exceed that which is normally possessed by a prudent person in the ordinary course of business dealings.

i. Except for transactions authorized under paragraph e of these instructions, if a participant in a covered transaction knowingly enters into a lower tier covered transaction with a person who is suspended, debarred, ineligible, or voluntarily excluded from participation in this transaction, in addition to other remedies available to the Federal Government, the department or agency with which this transaction originated may pursue available remedies, including suspension and/or debarment. 2 CFR 180.325.

\*\*\*\*\*

**Certification Regarding Debarment, Suspension, Ineligibility and Voluntary Exclusion--Lower Tier Participants:**

1. The prospective lower tier participant certifies, by submission of this proposal, that neither it nor its principals:

(a) is presently debarred, suspended, proposed for debarment, declared ineligible, or voluntarily excluded from participating in covered transactions by any Federal department or agency, 2 CFR 180.355;

(b) is a corporation that has been convicted of a felony violation under any Federal law within the two-year period preceding this proposal (USDOT Order 4200.6 implementing appropriations act requirements); and

(c) is a corporation with any unpaid Federal tax liability that has been assessed, for which all judicial and administrative remedies have been exhausted, or have lapsed, and that is not being paid in a timely manner pursuant to an agreement with the authority responsible for collecting the tax liability. (USDOT Order 4200.6 implementing appropriations act requirements)

2. Where the prospective lower tier participant is unable to certify to any of the statements in this certification, such prospective participant should attach an explanation to this proposal.

\*\*\*\*\*

**XI. CERTIFICATION REGARDING USE OF CONTRACT FUNDS FOR LOBBYING**

This provision is applicable to all Federal-aid construction contracts and to all related subcontracts which exceed \$100,000. 49 CFR Part 20, App. A.

1. The prospective participant certifies, by signing and submitting this bid or proposal, to the best of his or her knowledge and belief, that:

a. No Federal appropriated funds have been paid or will be paid, by or on behalf of the undersigned, to any person for influencing or attempting to influence an officer or employee of any Federal agency, a Member of Congress, an officer or employee of Congress, or an employee of a Member of Congress in connection with the awarding of any Federal contract, the making of any Federal grant, the making of any Federal loan, the entering into of any cooperative agreement, and the extension, continuation, renewal, amendment, or modification of any Federal contract, grant, loan, or cooperative agreement.

b. If any funds other than Federal appropriated funds have been paid or will be paid to any person for influencing or attempting to influence an officer or employee of any Federal agency, a Member of Congress, an officer or employee of Congress, or an employee of a Member of Congress in connection with this Federal contract, grant, loan, or cooperative agreement, the undersigned shall complete and submit Standard Form-LLL, "Disclosure Form to Report Lobbying," in accordance with its instructions.

2. This certification is a material representation of fact upon which reliance was placed when this transaction was made or entered into. Submission of this certification is a prerequisite for making or entering into this transaction imposed by 31 U.S.C. 1352. Any person who fails to file the required certification shall be subject to a civil penalty of not less than \$10,000 and not more than \$100,000 for each such failure.

3. The prospective participant also agrees by submitting its bid or proposal that the participant shall require that the language of this certification be included in all lower tier

subcontracts, which exceed \$100,000 and that all such recipients shall certify and disclose accordingly.

## **XII. USE OF UNITED STATES-FLAG VESSELS:**

This provision is applicable to all Federal-aid construction contracts, design-build contracts, subcontracts, lower-tier subcontracts, purchase orders, lease agreements, or any other covered transaction. 46 CFR Part 381.

This requirement applies to material or equipment that is acquired for a specific Federal-aid highway project. 46 CFR 381.7. It is not applicable to goods or materials that come into inventories independent of an FHWA funded-contract.

When oceanic shipments (or shipments across the Great Lakes) are necessary for materials or equipment acquired for a specific Federal-aid construction project, the bidder, proposer, contractor, subcontractor, or vendor agrees:

1. To utilize privately owned United States-flag commercial vessels to ship at least 50 percent of the gross tonnage (computed separately for dry bulk carriers, dry cargo liners, and tankers) involved, whenever shipping any equipment, material, or commodities pursuant to this contract, to the extent such vessels are available at fair and reasonable rates for United States-flag commercial vessels. 46 CFR 381.7.
2. To furnish within 20 days following the date of loading for shipments originating within the United States or within 30 working days following the date of loading for shipments originating outside the United States, a legible copy of a rated, 'on-board' commercial ocean bill-of-lading in English for each shipment of cargo described in paragraph (b)(1) of this section to both the Contracting Officer (through the prime contractor in the case of subcontractor bills-of-lading) and to the Office of Cargo and Commercial Sealift (MAR-620), Maritime Administration, Washington, DC 20590. (MARAD requires copies of the ocean carrier's (master) bills of lading, certified onboard, dated, with rates and charges. These bills of lading may contain business sensitive information and therefore may be submitted directly to MARAD by the Ocean Transportation Intermediary on behalf of the contractor). 46 CFR 381.7.



**ATTACHMENT A - EMPLOYMENT AND MATERIALS  
PREFERENCE FOR APPALACHIAN DEVELOPMENT  
HIGHWAY SYSTEM OR APPALACHIAN LOCAL ACCESS  
ROAD CONTRACTS (23 CFR 633, Subpart B, Appendix B)**

This provision is applicable to all Federal-aid projects funded under the Appalachian Regional Development Act of 1965.

1. During the performance of this contract, the contractor undertaking to do work which is, or reasonably may be, done as on-site work, shall give preference to qualified persons who regularly reside in the labor area as designated by the DOL wherein the contract work is situated, or the subregion, or the Appalachian counties of the State wherein the contract work is situated, except:

a. To the extent that qualified persons regularly residing in the area are not available.

b. For the reasonable needs of the contractor to employ supervisory or specially experienced personnel necessary to assure an efficient execution of the contract work.

c. For the obligation of the contractor to offer employment to present or former employees as the result of a lawful collective bargaining contract, provided that the number of nonresident persons employed under this subparagraph (1c) shall not exceed 20 percent of the total number of employees employed by the contractor on the contract work, except as provided in subparagraph (4) below.

2. The contractor shall place a job order with the State Employment Service indicating (a) the classifications of the laborers, mechanics and other employees required to perform the contract work, (b) the number of employees required in each classification, (c) the date on which the participant estimates such employees will be required, and (d) any other pertinent information required by the State Employment Service to complete the job order form. The job order may be placed with the State Employment Service in writing or by telephone. If during the course of the contract work, the information submitted by the contractor in the original job order is substantially modified, the participant shall promptly notify the State Employment Service.

3. The contractor shall give full consideration to all qualified job applicants referred to him by the State Employment Service. The contractor is not required to grant employment to any job applicants who, in his opinion, are not qualified to perform the classification of work required.

4. If, within one week following the placing of a job order by the contractor with the State Employment Service, the State Employment Service is unable to refer any qualified job applicants to the contractor, or less than the number requested, the State Employment Service will forward a certificate to the contractor indicating the unavailability of applicants. Such certificate shall be made a part of the contractor's permanent project records. Upon receipt of this certificate, the contractor may employ persons who do not normally reside in the labor area to fill positions covered by the certificate, notwithstanding the provisions of subparagraph (1c) above.

5. The provisions of 23 CFR 633.207(e) allow the contracting agency to provide a contractual preference for the use of mineral resource materials native to the Appalachian region.

6. The contractor shall include the provisions of Sections 1 through 4 of this Attachment A in every subcontract for work which is, or reasonably may be, done as on-site work.

APPENDIX C OF THE SUPPLEMENTARY CONDITIONS  
EXECUTIVE ORDER 11246 EQUAL EMPLOYMENT OPPORTUNITY

## **Executive Order 11246 - Equal Employment Opportunity**

SOURCE: The provisions of Executive Order 11246 of Sept. 24, 1965, appear at 30 FR 12319, 12935, 3 CFR, 1964-1965 Comp., p.339, unless otherwise noted.

Under and by virtue of the authority vested in me as President of the United States by the Constitution and statutes of the United States, it is ordered as follows:

### Part I - Nondiscrimination in Government Employment

[Part I superseded by EO 11478 of Aug. 8, 1969, 34 FR 12985, 3 CFR, 1966-1970 Comp., p. 803]

### Part II - Nondiscrimination in Employment by Government Contractors and Subcontractors

#### Subpart A - Duties of the Secretary of Labor

SEC. 201. The Secretary of Labor shall be responsible for the administration and enforcement of Parts II and III of this Order. The Secretary shall adopt such rules and regulations and issue such orders as are deemed necessary and appropriate to achieve the purposes of Parts II and III of this Order.

[Sec. 201 amended by EO 12086 of Oct. 5, 1978, 43 FR 46501, 3 CFR, 1978 Comp., p. 230]

#### Subpart B - Contractors' Agreements

SEC. 202. Except in contracts exempted in accordance with Section 204 of this Order, all Government contracting agencies shall include in every Government contract hereafter entered into the following provisions:

"During the performance of this contract, the contractor agrees as follows:

"(1) The contractor will not discriminate against any employee or applicant for employment because of race, color, religion, sex, or national origin. The contractor will take affirmative action to ensure that applicants are employed, and that employees are treated during employment, without regard to their race, color, religion, sex or national origin. Such action shall include, but not be limited to the following: employment, upgrading, demotion, or transfer; recruitment or recruitment advertising; layoff or termination; rates of pay or other forms of compensation; and selection for training, including apprenticeship. The contractor agrees to post in conspicuous places, available to employees and applicants for employment, notices to be provided by the contracting officer setting

forth the provisions of this nondiscrimination clause.

"(2) The contractor will, in all solicitations or advancements for employees placed by or on behalf of the contractor, state that all qualified applicants will receive consideration for employment without regard to race, color, religion, sex or national origin.

"(3) The contractor will send to each labor union or representative of workers with which he has a collective bargaining agreement or other contract or understanding, a notice, to be provided by the agency contracting officer, advising the labor union or workers' representative of the contractor's commitments under Section 202 of Executive Order No. 11246 of September 24, 1965, and shall post copies of the notice in conspicuous places available to employees and applicants for employment.

"(4) The contractor will comply with all provisions of Executive Order No. 11246 of Sept. 24, 1965, and of the rules, regulations, and relevant orders of the Secretary of Labor.

"(5) The contractor will furnish all information and reports required by Executive Order No. 11246 of September 24, 1965, and by the rules, regulations, and orders of the Secretary of Labor, or pursuant thereto, and will permit access to his books, records, and accounts by the contracting agency and the Secretary of Labor for purposes of investigation to ascertain compliance with such rules, regulations, and orders.

"(6) In the event of the contractor's noncompliance with the nondiscrimination clauses of this contract or with any of such rules, regulations, or orders, this contract may be cancelled, terminated, or suspended in whole or in part and the contractor may be declared ineligible for further Government contracts in accordance with procedures authorized in Executive Order No. 11246 of Sept. 24, 1965, and such other sanctions may be imposed and remedies invoked as provided in Executive Order No. 11246 of September 24, 1965, or by rule, regulation, or order of the Secretary of Labor, or as otherwise provided by law.

"(7) The contractor will include the provisions of paragraphs (1) through (7) in every subcontract or purchase order unless exempted by rules, regulations, or orders of the Secretary of Labor issued pursuant to Section 204 of Executive Order No. 11246 of September 24, 1965, so that such provisions will be binding upon each subcontractor or vendor. The contractor will take such action with respect to any subcontract or purchase order as may be directed by the Secretary of Labor as

a means of enforcing such provisions including sanctions for noncompliance: Provided, however, that in the event the contractor becomes involved in, or is threatened with, litigation with a subcontractor or vendor as a result of such direction, the contractor may request the United States to enter into such litigation to protect the interests of the United States." [Sec. 202 amended by EO 11375 of Oct. 13, 1967, 32 FR 14303, 3 CFR, 1966-1970 Comp., p. 684, EO 12086 of Oct. 5, 1978, 43 FR 46501, 3 CFR, 1978 Comp., p. 230]

SEC. 203. Each contractor having a contract containing the provisions prescribed in Section 202 shall file, and shall cause each of his subcontractors to file, Compliance Reports with the contracting agency or the Secretary of Labor as may be directed. Compliance Reports shall be filed within such times and shall contain such information as to the practices, policies, programs, and employment policies, programs, and employment statistics of the contractor and each subcontractor, and shall be in such form, as the Secretary of Labor may prescribe.

(b) Bidders or prospective contractors or subcontractors may be required to state whether they have participated in any previous contract subject to the provisions of this Order, or any preceding similar Executive order, and in that event to submit, on behalf of themselves and their proposed subcontractors, Compliance Reports prior to or as an initial part of their bid or negotiation of a contract.

(c) Whenever the contractor or subcontractor has a collective bargaining agreement or other contract or understanding with a labor union or an agency referring workers or providing or supervising apprenticeship or training for such workers, the Compliance Report shall include such information as to such labor union's or agency's practices and policies affecting compliance as the Secretary of Labor may prescribe: Provided, That to the extent such information is within the exclusive possession of a labor union or an agency referring workers or providing or supervising apprenticeship or training and such labor union or agency shall refuse to furnish such information to the contractor, the contractor shall so certify to the Secretary of Labor as part of its Compliance Report and shall set forth what efforts he has made to obtain such information.

(d) The Secretary of Labor may direct that any bidder or prospective contractor or subcontractor shall submit, as part of his Compliance Report, a statement in writing, signed by an authorized officer or agent on behalf of any labor union or any agency referring workers or providing or supervising apprenticeship or other training, with which the bidder or prospective contractor deals, with

supporting information, to the effect that the signer's practices and policies do not discriminate on the grounds of race, color, religion, sex or national origin, and that the signer either will affirmatively cooperate in the implementation of the policy and provisions of this Order or that it consents and agrees that recruitment, employment, and the terms and conditions of employment under the proposed contract shall be in accordance with the purposes and provisions of the order. In the event that the union, or the agency shall refuse to execute such a statement, the Compliance Report shall so certify and set forth what efforts have been made to secure such a statement and such additional factual material as the Secretary of Labor may require.

[Sec. 203 amended by EO 11375 of Oct. 13, 1967, 32 FR 14303, 3 CFR, 1966-1970 Comp., p. 684; EO 12086 of Oct. 5, 1978, 43 FR 46501, 3 CFR, 1978 Comp., p. 230]

SEC. 204. The Secretary of Labor may, when he/she deems that special circumstances in the national interest so require, exempt a contracting agency from the requirement of including any or all of the provisions of Section 202 of this Order in any specific contract, subcontract, or purchase order. The Secretary of Labor may, by rule or regulation, also exempt certain classes of contracts, subcontracts, or purchase orders (1) whenever work is to be or has been performed outside the United States and no recruitment of workers within the limits of the United States is involved; (2) for standard commercial supplies or raw materials; (3) involving less than specified amounts of money or specified numbers of workers; or (4) to the extent that they involve subcontracts below a specified tier. The Secretary of Labor may also provide, by rule, regulation, or order, for the exemption of facilities of a contractor which are in all respects separate and distinct from activities of the contractor related to the performance of the contract: Provided, That such an exemption will not interfere with or impede the effectuation of the purposes of this Order: And provided further, That in the absence of such an exemption, all facilities shall be covered by the provisions of this Order.

#### Subpart C - Powers and Duties of the Secretary of Labor and the Contracting Agencies

SEC. 205. The Secretary of Labor shall be responsible for securing compliance by all Government contractors and subcontractors with this Order and any implementing rules or regulations. All contracting agencies shall comply with the terms of this Order and any implementing rules, regulations, or orders of the Secretary of Labor. Contracting agencies shall cooperate with the Secretary of Labor and shall furnish such information and assistance as the Secretary may require.

[Sec. 205 amended by EO 12086 of Oct. 5, 1978, 43 FR 46501, 3 CFR, 1978 Comp., p. 230]

SEC. 206. The Secretary of Labor may investigate the employment practices of any Government contractor or subcontractor to determine whether or not the contractual provisions specified in Section 202 of this Order have been violated. Such investigation shall be conducted in accordance with the procedures established by the Secretary of Labor.

(b) The Secretary of Labor may receive and investigate complaints by employees or prospective employees of a Government contractor or subcontractor which allege discrimination contrary to the contractual provisions specified in Section 202 of this Order.

[Sec. 206 amended by EO 12086 of Oct. 5, 1978, 43 FR 46501, 3 CFR, 1978 Comp., p. 230]

SEC. 207. The Secretary of Labor shall use his/her best efforts, directly and through interested Federal, State, and local agencies, contractors, and all other available instrumentalities to cause any labor union engaged in work under Government contracts or any agency referring workers or providing or supervising apprenticeship or training for or in the course of such work to cooperate in the implementation of the purposes of this Order. The Secretary of Labor shall, in appropriate cases, notify the Equal Employment Opportunity Commission, the Department of Justice, or other appropriate Federal agencies whenever it has reason to believe that the practices of any such labor organization or agency violate Title VI or Title VII of the Civil Rights Act of 1964 or other provision of Federal law.

[Sec. 207 amended by EO 12086 of Oct. 5, 1978, 43 FR 46501, 3 CFR, 1978 Comp., p. 230]

SEC. 208. The Secretary of Labor, or any agency, officer, or employee in the executive branch of the Government designated by rule, regulation, or order of the Secretary, may hold such hearings, public or private, as the Secretary may deem advisable for compliance, enforcement, or educational purposes.

(b) The Secretary of Labor may hold, or cause to be held, hearings in accordance with Subsection of this Section prior to imposing, ordering, or recommending the imposition of penalties and sanctions under this Order. No order for debarment of any contractor from further Government

contracts under Section 209(6) shall be made without affording the contractor an opportunity for a hearing.

#### Subpart D - Sanctions and Penalties

SEC. 209. In accordance with such rules, regulations, or orders as the Secretary of Labor may issue or adopt, the Secretary may:

(1) Publish, or cause to be published, the names of contractors or unions which it has concluded have complied or have failed to comply with the provisions of this Order or of the rules, regulations, and orders of the Secretary of Labor.

(2) Recommend to the Department of Justice that, in cases in which there is substantial or material violation or the threat of substantial or material violation of the contractual provisions set forth in Section 202 of this Order, appropriate proceedings be brought to enforce those provisions, including the enjoining, within the limitations of applicable law, of organizations, individuals, or groups who prevent directly or indirectly, or seek to prevent directly or indirectly, compliance with the provisions of this Order.

(3) Recommend to the Equal Employment Opportunity Commission or the Department of Justice that appropriate proceedings be instituted under Title VII of the Civil Rights Act of 1964.

(4) Recommend to the Department of Justice that criminal proceedings be brought for the furnishing of false information to any contracting agency or to the Secretary of Labor as the case may be.

(5) After consulting with the contracting agency, direct the contracting agency to cancel, terminate, suspend, or cause to be cancelled, terminated, or suspended, any contract, or any portion or portions thereof, for failure of the contractor or subcontractor to comply with equal employment opportunity provisions of the contract. Contracts may be cancelled, terminated, or suspended absolutely or continuance of contracts may be conditioned upon a program for future compliance approved by the Secretary of Labor.

(6) Provide that any contracting agency shall refrain from entering into further contracts, or extensions or other modifications of existing contracts, with any noncomplying contractor, until such contractor has satisfied the Secretary of Labor that such contractor has established and will carry out



personnel and employment policies in compliance with the provisions of this Order.

(b) Pursuant to rules and regulations prescribed by the Secretary of Labor, the Secretary shall make reasonable efforts, within a reasonable time limitation, to secure compliance with the contract provisions of this Order by methods of conference, conciliation, mediation, and persuasion before proceedings shall be instituted under subsection (a)(2) of this Section, or before a contract shall be cancelled or terminated in whole or in part under subsection (a)(5) of this Section.

[Sec. 209 amended by EO 12086 of Oct. 5, 1978, 43 FR 46501, 3 CFR, 1978 Comp., p. 230]

SEC. 210. Whenever the Secretary of Labor makes a determination under Section 209, the Secretary shall promptly notify the appropriate agency. The agency shall take the action directed by the Secretary and shall report the results of the action it has taken to the Secretary of Labor within such time as the Secretary shall specify. If the contracting agency fails to take the action directed within thirty days, the Secretary may take the action directly.

[Sec. 210 amended by EO 12086 of Oct. 5, 1978, 43 FR 46501, 3 CFR, 1978 Comp., p. 230]

SEC. 211. If the Secretary shall so direct, contracting agencies shall not enter into contracts with any bidder or prospective contractor unless the bidder or prospective contractor has satisfactorily complied with the provisions of this Order or submits a program for compliance acceptable to the Secretary of Labor.

[Sec. 211 amended by EO 12086 of Oct. 5, 1978, 43 FR 46501, 3 CFR, 1978 Comp., p. 230]

SEC. 212. When a contract has been cancelled or terminated under Section 209(a)(5) or a contractor has been debarred from further Government contracts under Section 209(a)(6) of this Order, because of noncompliance with the contract provisions specified in Section 202 of this Order, the Secretary of Labor shall promptly notify the Comptroller General of the United States.

[Sec. 212 amended by EO 12086 of Oct. 5, 1978, 43 FR 46501, 3 CFR, 1978 Comp., p. 230]

#### Subpart E - Certificates of Merit

SEC. 213. The Secretary of Labor may provide for issuance of a United States Government Certificate of Merit to employers or labor unions, or other agencies which are or may hereafter be engaged in work under Government contracts, if the Secretary is satisfied that the personnel and

employment practices of the employer, or that the personnel, training, apprenticeship, membership, grievance and representation, upgrading, and other practices and policies of the labor union or other agency conform to the purposes and provisions of this Order.

SEC. 214. Any Certificate of Merit may at any time be suspended or revoked by the Secretary of Labor if the holder thereof, in the judgment of the Secretary, has failed to comply with the provisions of this Order.

SEC. 215. The Secretary of Labor may provide for the exemption of any employer, labor union, or other agency from any reporting requirements imposed under or pursuant to this Order if such employer, labor union, or other agency has been awarded a Certificate of Merit which has not been suspended or revoked.

### Part III - Nondiscrimination Provisions in Federally Assisted Construction Contracts

SEC. 301. Each executive department and agency, which administers a program involving Federal financial assistance shall require as a condition for the approval of any grant, contract, loan, insurance, or guarantee thereunder, which may involve a construction contract, that the applicant for Federal assistance undertake and agree to incorporate, or cause to be

incorporated, into all construction contracts paid for in whole or in part with funds obtained from the Federal Government or borrowed on the credit of the Federal Government pursuant to such grant,

contract, loan, insurance, or guarantee, or undertaken pursuant to any Federal program involving such grant, contract, loan, insurance, or guarantee, the provisions prescribed for Government contracts by Section 202 of this Order or such modification thereof, preserving in substance the contractor's obligations thereunder, as may be approved by the Secretary of Labor, together with such additional provisions as the Secretary deems appropriate to establish and protect the interest of

the United States in the enforcement of those obligations. Each such applicant shall also undertake

and agree (1) to assist and cooperate actively with the Secretary of Labor in obtaining the compliance of contractors and subcontractors with those contract provisions and with the rules, regulations and relevant orders of the Secretary, (2) to obtain and to furnish to the Secretary of Labor such information as the Secretary may require for the supervision of such compliance, (3) to

carry out sanctions and penalties for violation of such obligations imposed upon contractors and subcontractors by the Secretary of Labor pursuant to Part II, Subpart D, of this Order, and (4) to

refrain from entering into any contract subject to this Order, or extension or other modification of such a contract with a contractor debarred from Government contracts under Part II, Subpart D, of this Order.

[Sec. 301 amended by EO 12086 of Oct. 5, 1978, 43 FR 46501, 3 CFR, 1978 Comp., p. 230]

SEC. 302. "Construction contract" as used in this Order means any contract for the construction, rehabilitation, alteration, conversion, extension, or repair of buildings, highways, or other improvements to real property.

(b) The provisions of Part II of this Order shall apply to such construction contracts, and for purposes of such application the administering department or agency shall be considered the contracting agency referred to therein.

(c) The term "applicant" as used in this Order means an applicant for Federal assistance or, as determined by agency regulation, other program participant, with respect to whom an application for any grant, contract, loan, insurance, or guarantee is not finally acted upon prior to the effective date of this Part, and it includes such an applicant after he/she becomes a recipient of such Federal assistance.

SEC. 303. The Secretary of Labor shall be responsible for obtaining the compliance of such applicants with their undertakings under this Order. Each administering department and agency is directed to cooperate with the Secretary of Labor and to furnish the Secretary such information and assistance as the Secretary may require in the performance of the Secretary's functions under this Order.

(b) In the event an applicant fails and refuses to comply with the applicant's undertakings pursuant to this Order, the Secretary of Labor may, after consulting with the administering department or agency, take any or all of the following actions: (1) direct any administering department or agency to cancel, terminate, or suspend in whole or in part the agreement, contract or other arrangement with such applicant with respect to which the failure or refusal occurred; (2) direct any administering department or agency to refrain from extending any further assistance to the applicant under the program with respect to which the failure or refusal occurred until satisfactory assurance of future compliance has been received by the Secretary of Labor from such applicant; and (3) refer the case to the Department of Justice or the Equal Employment Opportunity Commission for appropriate law

enforcement or other proceedings.

(c) In no case shall action be taken with respect to an applicant pursuant to clause (1) or (2) of subsection (b) without notice and opportunity for hearing.

[Sec. 303 amended by EO 12086 of Oct. 5, 1978, 43 FR 46501, 3 CFR, 1978 Comp., p. 230]

SEC. 304. Any executive department or agency which imposes by rule, regulation, or order requirements of nondiscrimination in employment, other than requirements imposed pursuant to this

Order, may delegate to the Secretary of Labor by agreement such responsibilities with respect to compliance standards, reports, and procedures as would tend to bring the administration of such requirements into conformity with the administration of requirements imposed under this Order: Provided, That actions to effect compliance by recipients of Federal financial assistance with requirements imposed pursuant to Title VI of the Civil Rights Act of 1964 shall be taken in conformity with the procedures and limitations prescribed in Section 602 thereof and the regulations

of the administering department or agency issued thereunder.

#### Part IV - Miscellaneous

SEC. 401. The Secretary of Labor may delegate to any officer, agency, or employee in the Executive branch of the Government, any function or duty of the Secretary under Parts II and III of this Order.

[Sec. 401 amended by EO 12086 of Oct. 5, 1978, 43 FR 46501, 3 CFR, 1978 Comp., p. 230]

SEC. 402. The Secretary of Labor shall provide administrative support for the execution of the program known as the "Plans for Progress."

SEC. 403. Executive Orders Nos. 10590 (January 19, 1955), 10722 (August 5, 1957), 10925 (March 6, 1961), 11114 (June 22, 1963), and 11162 (July 28, 1964), are hereby superseded and the President's Committee on Equal Employment Opportunity established by Executive Order No.

10925 is hereby abolished. All records and property in the custody of the Committee shall be transferred to the Office of Personnel Management and the Secretary of Labor, as appropriate.

(b) Nothing in this Order shall be deemed to relieve any person of any obligation assumed or imposed under or pursuant to any Executive Order superseded by this Order. All rules, regulations,

orders, instructions, designations, and other directives issued by the President's Committee on Equal

Employment Opportunity and those issued by the heads of various departments or agencies under or

pursuant to any of the Executive orders superseded by this Order, shall, to the extent that they are

not inconsistent with this Order, remain in full force and effect unless and until revoked or superseded by appropriate authority. References in such directives to provisions of the superseded orders shall be deemed to be references to the comparable provisions of this Order.

[Sec. 403 amended by EO 12107 of Dec. 28, 1978, 44 FR 1055, 3 CFR, 1978 Comp., p, 264]

SEC. 404. The General Services Administration shall take appropriate action to revise the standard Government contract forms to accord with the provisions of this Order and of the rules and regulations of the Secretary of Labor.

SEC. 405. This Order shall become effective thirty days after the date of this Order.

APPENDIX D OF THE SUPPLEMENTARY  
CONDITIONS (OSHA) FORMS 300, 300A AND 301



# Summary of Work-Related Injuries and Illnesses



All establishments covered by Part 1904 must complete this Summary page, even if no work-related injuries or illnesses occurred during the year. Remember to review the Log to verify that the entries are complete and accurate before completing this summary.

Using the Log, count the individual entries you made for each category. Then write the totals below, making sure you've added the entries from every page of the Log. If you had no cases, write "0."

Employees, former employees, and their representatives have the right to review the OSHA Form 300 in its entirety. They also have limited access to the OSHA Form 301 or its equivalent. See 29 CFR Part 1904.35, in OSHA's recordkeeping rule, for further details on the access provisions for these forms.

## Number of Cases

Total number of deaths	Total number of cases with days away from work	Total number of cases with job transfer or restriction	Total number of other recordable cases
(G) _____	(H) _____	(I) _____	(J) _____

## Number of Days

Total number of days away from work	Total number of days of job transfer or restriction
(K) _____	(L) _____

## Injury and Illness Types

Total number of . . . (M)	(4) Poisonings	_____
(1) Injuries	(5) Hearing loss	_____
(2) Skin disorders	(6) All other illnesses	_____
(3) Respiratory conditions		_____

## Establishment information

Your establishment name \_\_\_\_\_  
 Street \_\_\_\_\_  
 City \_\_\_\_\_ State \_\_\_\_\_ ZIP \_\_\_\_\_

Industry description (e.g., *Manufacture of motor truck trailers*) \_\_\_\_\_

Standard Industrial Classification (SIC), if known (e.g., 3715) \_\_\_\_\_

OR \_\_\_\_\_

North American Industrial Classification (NAICS), if known (e.g., 336212) \_\_\_\_\_

**Employment information** (If you don't have these figures, see the Worksheet on the back of this page to estimate.)

Annual average number of employees \_\_\_\_\_

Total hours worked by all employees last year \_\_\_\_\_

## Sign here

**Knowingly falsifying this document may result in a fine.**

I certify that I have examined this document and that to the best of my knowledge the entries are true, accurate, and complete.

Company executive \_\_\_\_\_ Title \_\_\_\_\_  
 ( ) \_\_\_\_\_ / / \_\_\_\_\_  
 Phone \_\_\_\_\_ Date \_\_\_\_\_

**Post this Summary page from February 1 to April 30 of the year following the year covered by the form.**

Public reporting burden for this collection of information is estimated to average 58 minutes per response, including time to review the instructions, search and gather the data needed, and complete and review the collection of information. Persons are not required to respond to the collection of information unless it displays a currently valid OMB control number. If you have any comments about these estimates or any other aspects of this data collection, contact: US Department of Labor, OSHA Office of Statistical Analysis, Room N-3644, 200 Constitution Avenue, NW, Washington, DC 20210. Do not send the completed forms to this office.



# OSHA's Form 301 Injury and Illness Incident Report

This *Injury and Illness Incident Report* is one of the first forms you must fill out when a recordable work-related injury or illness has occurred. Together with the *Log of Work-Related Injuries and Illnesses* and the accompanying *Summary*, these forms help the employer and OSHA develop a picture of the extent and severity of work-related incidents.

Within 7 calendar days after you receive information that a recordable work-related injury or illness has occurred, you must fill out this form or an equivalent. Some state workers' compensation, insurance, or other reports may be acceptable substitutes. To be considered an equivalent form, any substitute must contain all the information asked for on this form.

According to Public Law 91-596 and 29 CFR 1904, OSHA's recordkeeping rule, you must keep this form on file for 5 years following the year to which it pertains.

If you need additional copies of this form, you may photocopy and use as many as you need.

Completed by \_\_\_\_\_  
Title \_\_\_\_\_  
Phone (\_\_\_\_) \_\_\_\_\_ Date \_\_\_\_/\_\_\_\_/\_\_\_\_

**Attention:** This form contains information relating to employee health and must be used in a manner that protects the confidentiality of employees to the extent possible while the information is being used for occupational safety and health purposes.



**U.S. Department of Labor**  
Occupational Safety and Health Administration

Form approved OMB no. 1218-0176

## Information about the employee

- 1) Full name \_\_\_\_\_
- 2) Street \_\_\_\_\_  
City \_\_\_\_\_ State \_\_\_\_\_ ZIP \_\_\_\_\_
- 3) Date of birth \_\_\_\_/\_\_\_\_/\_\_\_\_
- 4) Date hired \_\_\_\_/\_\_\_\_/\_\_\_\_
- 5)  Male  
 Female

## Information about the physician or other health care professional

- 6) Name of physician or other health care professional \_\_\_\_\_
- 7) If treatment was given away from the worksite, where was it given?  
Facility \_\_\_\_\_  
Street \_\_\_\_\_  
City \_\_\_\_\_ State \_\_\_\_\_ ZIP \_\_\_\_\_
- 8) Was employee treated in an emergency room?  
 Yes  
 No
- 9) Was employee hospitalized overnight as an in-patient?  
 Yes  
 No

## Information about the case

- 10) Case number from the Log \_\_\_\_\_ (Transfer the case number from the Log after you record the case.)
- 11) Date of injury or illness \_\_\_\_/\_\_\_\_/\_\_\_\_ AM / PM
- 12) Time employee began work \_\_\_\_\_ AM / PM
- 13) Time of event \_\_\_\_\_ AM / PM  Check if time cannot be determined
- 14) **What was the employee doing just before the incident occurred?** Describe the activity, as well as the tools, equipment, or material the employee was using. Be specific. *Examples:* "climbing a ladder while carrying roofing materials"; "spraying chlorine from hand sprayer"; "daily computer key-entry."
- 15) **What happened?** Tell us how the injury occurred. *Examples:* "When ladder slipped on wet floor, worker fell 20 feet"; "Worker was sprayed with chlorine when gasket broke during replacement"; "Worker developed soreness in wrist over time."
- 16) **What was the injury or illness?** Tell us the part of the body that was affected and how it was affected; be more specific than "hurt," "pain," or "sore." *Examples:* "strained back"; "chemical burn, hand"; "carpal tunnel syndrome."
- 17) **What object or substance directly harmed the employee?** *Examples:* "concrete floor"; "chlorine"; "radial arm saw." If this question does not apply to the incident, leave it blank.
- 18) **If the employee died, when did death occur?** Date of death \_\_\_\_/\_\_\_\_/\_\_\_\_

APPENDIX E OF THE SUPPLEMENTARY CONDITIONS  
SMALL BUSINESS DIVISION  
PROJECT WORKSHEET



# Small Business Development Division

## Project Worksheet

Project/Contract Title: Venetian Causeway Bridges No. 874459 and No. 874474 – Hurricane Irma Repairs Received Date: 2/3/2023

Project/Contract No: 20230004 Funding Source: FEMA Reimbursement

Department: Transportation & Public Works

Estimated Cost of Project/Bid: \$640,580.00

Description of Project/Bid: Tasks to be performed include, but is not limited to the following: Remove components from the existing damaged timber fender system including, wales, spacer blocks, catwalk planks, deck supports, all associated connections and wire ropes, and install new wales, spacer blocks, catwalk planks, deck supports, wire ropes and handrail at both bridges; Remove and replace fender navigational light system at both bridges; Remove and replace existing damaged ladders platforms at both bridges; Remove and replace existing damaged roof tiles at both bridge tender houses. Care to be taken not to allow any damaged tile to fall into water or adjacent sidewalk area. Damaged tile not eligible for repair to be disposed of in accordance with plans; Remove and replace bitumen roof at the East Bridge Generator Building; Repair spalls with exposed reinforcing as per specifications and plans at existing fender concrete piles, at both bridges;

Contract Measures Recommendation		
Measure	Program	Goal Percent
Aspirational Goal	DBE	10.65%
Reasons for Recommendation		
<p><b>SMALL BUSINESS ENTERPRISE -CONSTRUCTION (SBE-Con)</b></p> <p>SBD reviewed this project pursuant to Implementing Order 3-22 for SBE-Con measure. Project information analyzed included the project's scope of services, estimated project cost, minimum requirements/qualifications and funding source; these indicate a No Measure is appropriate for this contract due to the funding source (FEMA Reimbursement Funds).</p> <p>Project 20230004 will have a 10.65% aspirational Disadvantaged Business Enterprise (DBE) Goal recommended by Department of Transportation and Public Works (DTPW)</p> <p>Davis-Bacon Heavy wages apply to this project</p> <p>CWP Not applicable: Funding Source.</p> <p>NAICS 237310 Highway, Street, and Bridge Construction</p>		

Living Wages: YES  NO  Highway: YES  NO  Heavy Construction: YES  NO

Davis-Bacon Wages: YES  NO  Building: YES  NO

  
SBD Director

2-8-23  
Date

## **SECTION 6: SPECIFICATIONS**

## GENERAL REQUIREMENTS

DTPW SPECIFICATIONS  
GENERAL REQUIREMENTS  
TABLE OF CONTENTS

**1. GENERAL REQUIREMENTS**

---

1.01	DEFINITIONS AND TERMINOLOGY.....	1
A.	General .....	1
B.	Governing Regulations and Standard References .....	1
C.	Abbreviations .....	2
D.	Definitions .....	3
1.02	WORK COVERED BY THE CONTRACT DOCUMENTS.....	6
A.	Intent of Contract and Contract Documents .....	6
B.	Alteration of Plans or of Character of Work .....	6
C.	Connections to Existing Pavement, Drives and Walks .....	6
D.	Differing Site Conditions.....	7
E.	Underground Facilities. ....	7
F.	Contractor Proposed Changes Affecting Utilities .....	8
G.	Rights in and Use of Materials Found on the Site of the Work.....	8
H.	Restoration of Property .....	8
I.	Final Cleaning Up of Right-of-Way.....	9
1.03	CONTROLLING WORK .....	9
A.	Plans .....	9
B.	Typical Details and/or Sketches .....	9
C.	Or-Equals and Substitutes .....	10
D.	Right Of Way Verification .....	11
E.	Shop Drawings.....	11
F.	Coordination of Contract Documents .....	15
G.	Conformity of Work with Contract Documents.....	15
H.	Errors or Omissions in Contract Documents .....	15
I.	Authority of Engineer.....	15
J.	Authority and Duties of Engineer's Assistants.....	15
K.	Engineering and Layout .....	15
L.	Contractor's Supervision .....	17
M.	General Inspection Requirements.....	17
N.	Final Inspection .....	17
O.	Final Acceptance.....	18
1.04	CONTROLLING MATERIALS .....	18
A.	Acceptance Criteria .....	18
B.	Applicable Documented Authorities Other Than Specifications .....	19
C.	Storage of Materials and Samples .....	19
D.	Defective Materials.....	19
E.	Products and Source of Supply.....	19
1.05	LEGAL REQUIREMENTS AND RESPONSIBILITY TO THE PUBLIC.....	20
A.	Disaster Preparedness.....	20
B.	Laws to be Observed .....	21
C.	Permits and Licenses.....	24

D.	Patented Devices, Materials and Processes.....	25
E.	Right-of-Way Furnished by the Department.....	25
F.	Sanitary Provisions.....	25
G.	Control of Contractor's Equipment.....	25
H.	Contractor's Equipment on Bridge Structures.....	25
I.	Structures over Navigable Waters.....	26
J.	Manatee Protection.....	26
K.	Forest Protection.....	27
L.	Preservation of Property.....	27
M.	Responsibility for Damages, Claims, etc.....	30
N.	Contractor's Responsibility for Work.....	30
O.	Opening Sections of Roadway to Traffic.....	30
P.	Scales for Weighing Materials.....	30
Q.	Source of Forest Products.....	30
R.	Dust Control.....	31
S.	Dredging and Filling.....	31
T.	Contractor's Motor Vehicle Registration.....	31
U.	Compliance with FHWA 1273:.....	31
1.06	PROSECUTION AND PROGRESS.....	31
A.	Subletting Or Assigning The Contract.....	31
B.	Notice to Proceed.....	32
C.	Project Signs.....	32
D.	Schedule Of Values.....	32
E.	Preconstruction Conference.....	32
F.	Scheduling of the Work.....	33
G.	Progress of the Work.....	35
H.	Performance of Work.....	36
I.	As-Built Drawings.....	36
J.	Liquidated Damages.....	36
K.	Limitations of Operations.....	37
L.	Qualifications of Contractor's Personnel.....	39
M.	Temporary Suspension of Contractor's Operations.....	39
N.	Computation of Contract Time.....	40
O.	Default and Termination of Contract.....	41
P.	Release of Contractor's Responsibility.....	43
1.07	MEASUREMENT AND PAYMENT.....	43
A.	Compensation.....	43
B.	Contingency Allowance Account.....	43
C.	Florida Power And Light Connection Allowance.....	43
D.	Retainage; Punch List Requirements.....	43
E.	Measurement of Quantities.....	44
F.	Fuel Adjustment.....	44
G.	Bituminous Material.....	45
H.	Material Adjustments for Aluminum, PVC, and Copper.....	45
I.	Material Adjustments for Steel Guardrail.....	46
J.	Lump Sum Quantities.....	47
K.	Deleted Work.....	47
L.	Partial Payments.....	47
M.	Record of Construction Materials.....	48
N.	Recovery Rights, Subsequent to Final Payment.....	48

## 1. GENERAL REQUIREMENTS

---

### 1.01 DEFINITIONS AND TERMINOLOGY

#### A. General

1. These Specifications are written to the bidders, prior to award of the Contract, and to Contractor.
2. Where sentences directing work or other action appear in the active voice-imperative mood, without a subject, the subject "bidder" or "Contractor" is understood. In any other case where the subject is not clearly understood, Engineer will make a clarification and final determination as to the subject of the action.

#### B. Governing Regulations and Standard References

1. The following Standards and Governing Regulations, as amended by the Contract Documents, are hereby incorporated by reference:
  - a. Building Code as set forth in Chapter 8 of the Code of Miami-Dade County.
  - b. Public Works Manual of Metropolitan Dade County (Public Works Manual).
  - c. United States Department of Justice's 2010 ADA Standards For Accessible Design
  - d. Miami-Dade County's Traffic Control Equipment Specifications and Standards for The Metro Traffic Control System Miami-Dade County (TCESS).
  - e. Florida Department of Transportation's Standard Plans for Road and Bridge Construction (FDOT Standard Plans).  
<http://www.fdot.gov/design/standardplans/SPRBC.shtm>
  - f. Florida Department of Transportation Standard Specifications for Road and Bridge Construction (Divisions II & III), Special Provisions and Supplemental Specifications  
<http://www.fdot.gov/programmanagement/Implemented/SpecBooks/default.shtm>
  - g. Florida Department of Transportation Surveying and Mapping Procedure  
<http://fdotwp1.dot.state.fl.us/ProceduresInformationManagementSystemInternet/FormsAndProcedures/ViewDocument?topicNum=550-030-101>
  - h. Florida Department of Transportation Drainage Manual  
<http://www.fdot.gov/roadway/Drainage/Manualsandhandbooks.shtm>
  - i. Florida Department of Transportation Soils and Foundations Handbook  
<http://www.fdot.gov/structures/DocsandPubs.shtm>
  - j. Florida Department of Transportation Structures Manual

<http://www.fdot.gov/structures/DocsandPubs.shtm>

- k. Florida Department of Transportation Current Structures Design Bulletins

<http://www.fdot.gov/structures/Memos/currentbulletins.shtm>

- l. Manual on Uniform Traffic Control Devices (MUTCD)

<https://mutcd.fhwa.dot.gov/>

- m. Safe Mobility For Life Program Policy Statement

<http://www.fdot.gov/traffic/TrafficServices/SafetyisGolden.shtm>

- n. Florida Department of Transportation American with Disabilities Act (ADA) Compliance

<http://www.fdot.gov/roadway/ada/>

- o. Florida Department of Transportation Florida Sampling and Testing Methods

<http://www.fdot.gov/materials/administration/resources/library/publications/fstm/disclaimer.shtm>

- p. Florida Department of Transportation Flexible Pavement Coring and Evaluation Procedure

<http://www.fdot.gov/materials/administration/resources/library/publications/materialsmanual/documents/v1-section32-clean.pdf>

- q. Florida Department of Transportation Design Bulletins and Update Memos

<http://www.fdot.gov/roadway/Bulletin/>

- r. Florida Department of Transportation Utility Accommodation Manual

<http://www.fdot.gov/programmanagement/utilities/default.shtm>

- s. Florida Department of Transportation Flexible Pavement Design Manual

<http://www.fdot.gov/roadway/pm/pcs/flexiblepavementmanual.pdf>

- t. Florida Department of Transportation Rigid Pavement Design Manual

<http://www.fdot.gov/roadway/pm/pcs/rigidpavementmanual.pdf>

- u. Florida Department of Transportation Pavement Type Selection Manual

<http://www.fdot.gov/roadway/pm/Publications/PTSM.pdf>

- v. Florida Department of Transportation Traffic Engineering Manual

<http://www.fdot.gov/traffic/trafficservices/Studies/TEM/TEM.shtm>

- w. Florida Department of Transportation Bicycle and Pedestrian Policies and Standards

<http://www.fdot.gov/roadway/bikeped/default.shtm>

- x. Federal Highway Administration Hydraulic Engineering Circular Number 18 (HEC 18).



[https://www.fhwa.dot.gov/engineering/hydraulics/library\\_listing.cfm](https://www.fhwa.dot.gov/engineering/hydraulics/library_listing.cfm)

y. Florida Department of Transportation Manual of Uniform Minimum Standards for Design, Construction and Maintenance for Streets and Highways (Florida Greenbook)

[http://www.fdot.gov/roadway/floridagreenbook/fg\\_b.shtml](http://www.fdot.gov/roadway/floridagreenbook/fg_b.shtml)

z. Florida Department of Transportation Project Development and Environment Manual, Parts 1 and 2  
[http://www.fdot.gov/environment/pubs/pdem\\_an/pdeman1.shtml](http://www.fdot.gov/environment/pubs/pdem_an/pdeman1.shtml)

aa. Florida Department of Transportation Contract Compliance Manual.  
<https://www.fdot.gov/equalopportunity/contractcompliancemanual.shtml>

bb. Florida Department of Transportation Equal Opportunity Compliance (EOC) System.  
<https://www.fdot.gov/equalopportunity/eoc.shtml>

cc. Florida Statutes  
<http://www.leg.state.fl.us/statutes/>

dd. Miami-Dade County and Local Municipal Ordinances, unless otherwise is prohibited, by State or Federal regulations.

2. The above list is not all inclusive and it is the responsibility of Contractor to comply with all applicable requirements whether included in this list or not. Additional project-specific criteria are provided throughout the Contract Documents

3. The above referenced Standards are intended to supplement, not supersede the requirements set forth herein and, unless otherwise noted, the latest revision shall apply. Where differences occur between referenced Standards and these Contract Documents, the more stringent shall apply unless otherwise noted in the Contract Documents or directed by Engineer in writing.

4. FDOT Standard Specifications.

a. FDOT Standard Specifications for Road and Bridge Construction (Divisions II & III), as amended by the Contract Documents, apply to an Article within these Specifications when:

1) The applicable FDOT Standard Specification Section (e.g. FDOT SECTION 415) is referenced in the title of the Article; or

2) The FDOT Standard Specification section, article, or subarticle is referenced within the Article (e.g. FDOT Section 415, FDOT 415-3; FDOT 415-5.1, etc.)

b. Unless otherwise specified, where page numbers are used in these Specifications to reference modifications to the FDOT Standard Specifications, it shall be understood to reference the 2007 edition.

#### C. Abbreviations

The following abbreviations, when used in the Contract Documents, represent the full text shown.

AAN	American Association of Nurserymen, Inc.
AASHTO	American Association of State Highway and Transportation Officials
ACI	American Concrete Institute
AGC	The Associated General Contractors of America, Inc.
AGMA	American Gear Manufacturers Association
AIA	American Institute of Architects.
AISI	American Iron and Steel Institute
ANSI	American National Standards Institute, Inc.
APL	FDOT Approved Product List
AREA	American Railway Engineering Association
ASCE	American Society of Civil Engineers
ASME	American Society of Mechanical Engineers
ASTM	American Society for Testing and Materials
ATSSA	American Traffic Safety Services Association
AWG	American Wire Gauge
AWPA	American Wood Preservers Association
AWS	American Welding Society
AWWA	American Water Works Association
CFR	Code of Federal Regulations
CRSI	Concrete Reinforcing Steel Institute
DOL	U.S. Department of Labor
EASA	Electrical Apparatus Service Association
EPA	Environmental Protection Agency of the United States Government
F.A.C.	Florida Administrative Code
FBC	Florida Building Code
FDEP	Florida Department of Environmental Protection
FDOH	Florida Department of Health
FDOT	Florida Department of Transportation
FHWA	Federal Highway Administration
FM	Florida Method or Florida Sampling and Testing Method
F.S.	Florida Statutes
FSS	Federal Specifications and Standards
IEEE	Institute of Electrical and Electronics Engineers
IES	Illuminating Engineering Society
IMSA	International Municipal Signal Association
IPCEA	Insulated Power Cable Engineers Association
ISO	International Organization for Standards
MDC	Miami-Dade County
MSTCSD	Minimum Specifications for Traffic Control Signals and Devices
NAM	Negotiated Acceptance Memorandum
MUTCD	Manual on Uniform Traffic Control Devices
NEC	National Electrical Code
NEMA	National Electrical Manufacturers Association
NESC	National Electrical Safety Code
NFPA	National Fire Protection Association
NIST	National Institute for Standards and Technology
NOAA	National Oceanic and Atmospheric Administration
NSF	NSF International
OSHA	Occupational Safety and Health Administration

PCA	Portland Cement Association
DTPW	Miami-Dade County Department of Transportation and Public Works
SAE	Society of Automotive Engineers
SBE-CONST	Small Business Enterprise-Construction
SI	International System of Units
SSPC	Society of Protective Coatings
TSSQPL	Traffic Signals and Signs Qualified Products List
UL	Underwriters' Laboratories
U.S.C.	United States Code

#### D. Definitions

The following terms, when used in the Specifications, have the meaning described.

1. Article. The numbered prime subdivision of a Division of these Specifications.
2. Bracing. A temporary structural member(s) placed between beams, girders, piles columns, etc. to provide stability during construction activities.
3. Bridge. A structure, including supports, erected over a depression or over an obstruction such as water, highway or railway, or for elevated roadway, for carrying traffic or other moving loads, and having a length, measured along the center of the roadway, of more than 20 feet between the inside faces of end supports. A multiple-span box culvert is considered a bridge, where the length between the extreme ends of the openings exceeds 20 feet.
4. Calendar day. Every day shown on the calendar, ending and beginning at midnight. Unless otherwise stipulated in the Contract Documents, the term "days" shall be understood as calendar days. In computing any period of time prescribed or allowed by this Contract, the day of the act, event, or default from which the designated period of time begins to run shall not be included. The last day of the period so computed shall be included unless it is a Saturday, Sunday, or legal holiday, in which event the period shall run until the end of the next day which is neither a Saturday, Sunday, or legal holiday. When the period of time prescribed or allowed is less than 7 days, intermediate Saturdays, Sundays, and legal holidays shall be excluded in the computation.
5. Construction Affecting Public Safety. Construction that may jeopardize public safety such as structures spanning functioning vehicular roadways, pedestrian walkways, railroads, navigation channels of navigable waterways and walls or other structure foundations located in embankments immediately adjacent to functioning roadways. It does not apply to those areas of the site under Contractor's control and outside the limits of normal public access.
6. Contract. The term "Contract" means the entire and integrated agreement between the parties thereunder and supersedes all prior negotiations, representations, or agreements, either written or oral. The executed Contract Documents form the Contract between the Department (on behalf of the County) and Contractor setting forth the obligations of the parties thereunder,

including, but not limited to, the performance of the Work and the basis of payment.

7. Contract Documents. Consists of those items so designated in and inclusive of the executed Contract. Only printed or hard copies of the items listed in the executed Contract Form are Contract Documents.
8. Contract Time. The maximum number of calendar days, including authorized time extensions, allowed for final completion of all Contract work and requirements. Also called Contract Duration.
9. Contract Unit Price. Refers to the Unit Price provided by the Contract that is fixed at time of Contract award.
10. Contractor. The individual, firm, joint venture, or company contracting with the County to perform the Work pursuant to the Contract.
11. Contractor's Engineer of Record.
  - a. A Professional Engineer registered in the State of Florida, other than the Engineer of Record or his subcontracted consultant, who undertakes the design and drawing of components of the permanent structure as part of a redesign, or for repair designs and details of the permanent work. Contractor's Engineer of Record may also serve as the Specialty Engineer.
  - b. Contractor's Engineer of Record must be an employee of a pre-qualified firm. The firm shall be pre-qualified in accordance with the Rule 14-75, F.A.C. Any Corporation or Partnership offering engineering services must hold a Certificate of Authorization from the Florida Board of Professional Engineers.
  - c. As an alternate to being an employee of a pre-qualified firm, Contractor's Engineer of Record may be a pre-qualified Specialty Engineer. For items of the permanent Work declared by the FDOT Construction Office to be "major" or "structural", the work performed by a pre-qualified Specialty Engineer must be checked by another pre-qualified Specialty Engineer. An individual Engineer may become pre-qualified in the work groups listed in Rule 14-75, F.A.C., if the requirements for the Professional Engineer are met for the individual work groups. Pre-qualified Specialty Engineers are listed on the FDOT Construction Office website. Pre-qualified Specialty Engineers will not be authorized to perform redesigns of items fully detailed in the Plans.
12. Contractor Originated Designs. Items which the Contract Documents require Contractor to design, detail and incorporate into the permanent works.
13. Controlling Work Items. The activity or work item on the critical path having the least amount of total float. The controlling item of work will also be referred to as a Critical Activity.
14. County. Miami-Dade County, Florida.

15. Culverts. Any structure not classified as a bridge that provides an opening under the roadway.
16. Department. Miami-Dade County Department of Transportation and Public Works.
17. Engineer. The County Engineer, acting directly or through duly authorized representatives; such representatives acting within the scope of the duties and authority assigned to them.
  - a. Note: In order to avoid cumbersome and confusing repetition of expressions in these Specifications, it is provided that whenever anything is, or is to be done, if, as, or, when, or where "acceptable, accepted, approval, approved, authorized, condemned, considered necessary, contemplated, deemed necessary, designated, determined, directed, disapproved, established, given, indicated, insufficient, ordered, permitted, rejected, required, reserved, satisfactory, specified, sufficient, suitable, suspended, unacceptable, or unsatisfactory," it shall be understood as if the expression were followed by the words "by Engineer," "by the Engineer," "to the Engineer," or "of the Engineer."
18. Engineer of Record. The Professional Engineer or Engineering Firm registered in the State of Florida that develops the criteria and concept for the project, performs the analysis, and is responsible for the preparation of the Plans and Specifications. The Engineer of Record may be Departmental in-house staff, or a consultant retained by the Department. Contractor shall not employ the Engineer of Record as Contractor's Engineer of Record or as a Specialty Engineer.
19. Equipment. The machinery and equipment, together with the necessary supplies for upkeep and maintenance thereof, and all other tools and apparatus necessary for the construction and acceptable completion of the work.
20. Extra Work. Any "work" which is required by Engineer to be performed and which is not otherwise covered or included in the project by the existing Contract Documents, whether it be in the nature of additional work, altered work, deleted work, work due to differing site conditions, or otherwise. This term does not include a "delay".
21. Falsework. Includes any temporary construction work used to support the permanent structure until it becomes self-supporting. Falsework includes steel or timber beams, girders, columns, piles and foundations, and any proprietary equipment including modular shoring frames, post shores, and adjustable horizontal shoring.
22. Formwork. Includes any structure or mold used to retain plastic or fluid concrete in its designated shape until it hardens. Formwork comprises common materials such as wood or metal sheets, battens, soldiers and walers, ties, proprietary forming systems such as stay-in-place metal forms, and proprietary supporting bolts, hangers and brackets. Formwork may be either permanent formwork requiring a shop drawing submittal such as stay-in-place metal or concrete forms, or may be temporary formwork which requires certification by the Specialty Engineer for Construction Affecting Public Safety and for Major and Unusual Structures.
23. Highway, Street, or Road. A general term denoting a public way for purposes of vehicular travel, including the entire area within the right-of-way.
24. Holidays. Days designated by Miami-Dade County as holidays, which include, but are not limited to, New Year's Day, Martin Luther King's Birthday, President's Day, Memorial Day, Independence Day, Labor Day, Columbus Day, Veterans Day, Thanksgiving Day and the following Friday, and Christmas Day.
25. Inspector. An authorized representative of the Engineer, assigned to make official inspections of the materials furnished and of the work performed by Contractor.
26. Laboratory. The official testing laboratory authorized by the Department.
27. Major and Unusual Structures: Bridges of complex geometry and/or complex design. Generally, this includes the following types of structures:
  - a. Bridges with an individual span longer than 300 feet.
  - b. Structurally continuous superstructures with spans over 150 feet.
  - c. Steel box and plate girder bridges.
  - d. Steel truss bridges.
  - e. Concrete segmental and longitudinally post-tensioned continuous girder bridges.
  - f. Cable stayed or suspension bridges.
  - g. Arch bridges.
  - h. Tunnels.
  - i. Movable bridges (specifically electrical and mechanical components).
  - j. Rehabilitation, widening, or lengthening of any of the above.
28. Major Item of Work. Any item of work having an original Contract value in excess of 5% of the original Contract amount.
29. Materials. Any substances to be incorporated in the work under the Contract.
30. Median. The portion of a divided highway or street separating the traveled ways for traffic moving in opposite directions.
31. Permanent Works. All the permanent structures and parts thereof required of the completed Contract.
32. Plans. The part of the Contract Documents prepared or approved by the Engineer, including reproductions thereof, which graphically shows or supplements the scope, extent, and character of the Work to be performed by Contractor. Whenever the word "Plans" appears in these Contract Documents, it shall include any related drawings or standard details referenced by the Contract Documents.

33. Right-of-Way. The land that the Department has title to, or right of use, for the road and its structures and appurtenances, and for material pits furnished by the Department.
34. Roadbed. The portion of the roadway occupied by the subgrade and shoulders.
35. Roadway. The portion of a highway within the limits of construction.
36. Scaffolding. An elevated work platform used to support workmen, materials and equipment, but not intended to support the structure.
37. Section. A numbered prime division of these Specifications.
38. Shop Drawings. All working, shop and erection drawings, associated trade literature, calculations, schedules, manuals and similar documents submitted by Contractor to define some portion of the Work. The Work may include both permanent and temporary works as appropriate to the Project. Shop Drawings and other contractor submittals are not Plans as so defined.
39. Shoring. A component of falsework such as horizontal, vertical or inclined support members. In this Section, this term is interchangeable with falsework.
40. Special Erection Equipment. Includes launching gantries, beam and winch equipment, form travelers, stability towers, strong-backs, erection trusses, launching noses or similar items made purposely for construction of the structure. It does not apply to commonly available proprietary construction equipment such as cranes.
41. Special Provisions. Project specific clauses adopted by the Department that add to or revise these Specifications and associated supplemental specifications, or provide other requirements applicable to the Contract.
42. Specialty Engineer.
  - a. A Professional Engineer registered in the State of Florida, other than the Engineer of Record or his subcontracted consultant, who undertakes the design and drawing preparation of components, systems, or installation methods and equipment for specific temporary portions of the Work or for special items of the permanent works not fully detailed in the plans and required to be furnished by Contractor such as but not limited to pot bearing designs, non-standard expansion joints, mechanically stabilized earth wall designs and other specialty items. The Specialty Engineer may also provide designs and details for items of the permanent work declared by the FDOT Construction Office to be "minor" or "non-structural". The Specialty Engineer may be an employee or officer of Contractor or a fabricator, an employee or officer of an entity providing components to a fabricator, or an independent consultant.
    - b. For items of work not specifically covered by Rule 14-75, F.A.C., a Specialty Engineer is qualified if he has the following qualifications:
      - 1) Registration as a Professional Engineer in the State of Florida.
      - 2) The education and experience necessary to perform the submitted design as required by the Florida Board of Professional Engineers.
43. Specifications. The directions, provisions, and requirements contained herein, together with all stipulations contained in the Contract Documents, setting out or relating to the method and manner of performing the work, or to the quantities and qualities of materials and labor to be furnished under the Contract.
44. State. State of Florida.
45. Structure. Any waterworks, drainage works, sewage works, river works, earthworks or constructions of any kind, including those of earth or rock, permanent or temporary, and including bridges, dam, wall, caisson, mast, tower, pylon, underground tank, earth retaining elements or assembly of elements, formwork, falsework, scaffold, fences, poles, buildings, pavings, inlets, levees, tide gates, spillways, drop structures, any structure similar to the foregoing, and any other form of building, construction, arrangement of parts, elements, or materials found in structures.
46. Subarticle. A prime subdivision of an Article of these Specifications.
47. Subgrade. The portion of the roadbed immediately below the base course or pavement, including below the curb and gutter, valley gutter, shoulder and driveway pavement. The subgrade limits ordinarily include those portions of the roadbed shown in the plans to be constructed to a design bearing value or to be otherwise specially treated. Where no limits are shown in the plans, the subgrade section extends to a depth of 12 inches below the bottom of the base or pavement and outward to 6 inches beyond the base, pavement, or curb and gutter.
48. Substantial Completion. The time and date at which the Work has progressed to the point where, in the opinion of Engineer, the Work is sufficiently complete, in accordance with the Contract Documents, so that the Work can be occupied and/or utilized for the purposes for which it is intended. Substantial Completion must occur before the Project is issued a Certificate of Occupancy (or Completion, if applicable) by the Department that allows the County to utilize the entire Project for the purposes for which it is intended. Substantial completion on roadway projects includes completion and operation of traffic signals, street lighting and completion of landscape items.
49. Substructure. All of that part of a bridge structure below the bridge seats, including the parapets, backwalls, and wingwalls of abutments.
50. Superintendent. Contractor's authorized representative in responsible charge of the work.

51. Superstructure. The entire bridge structure above the substructure, including anchorage and anchor bolts, but excluding the parapets, backwalls, and wingwalls of abutments.
52. Surety. The corporate body that is bound by the Contract Bond with and for Contractor and responsible for the performance of the Contract and for payment of all legal debts pertaining thereto.
53. Temporary Works. Any temporary construction work necessary for the construction of the permanent works. This includes but is not limited to bracing, falsework, formwork, scaffolding, shoring, temporary earthworks, sheeting, cofferdams, and special erection equipment.
54. Traveled Way. The portion of the roadway providing for the movement of vehicles, exclusive of shoulders and auxiliary lanes.
55. Traffic Control Signals and Devices. Any signal or device, manually, electrically or mechanically operated, by which traffic is alternately directed to stop and permitted to proceed or controlled in any manner. Traffic control signals and devices regulate, warn, or guide traffic on, over or adjacent to a street, highway, pedestrian facility, or bikeway by authority of a public agency having jurisdiction. Traffic control signals and devices include, but are not limited to, controller assemblies (controller cabinets and their contents); signal heads including their hanging or mounting devices; vehicle detection systems (loops, sealant, amplifier, lead-in wire, or cable); pedestrian detection systems (push button, push button housing, lead-in wires, and signal); motorist information systems, video equipment, network devices, dynamic message signs, highway advisory radios, cameras, vehicle detection systems, and other equipment used within a traffic control system.
56. Underground Facilities. All underground pipelines, conduits, ducts, cables, wires, manholes, vaults, tanks, tunnels, or other such facilities or attachments, and any encasements containing such facilities, including those that convey electricity, gases, steam, liquid petroleum products, telephone or other communications, cable television, water, wastewater, storm water, other liquids or chemicals, or traffic or other control systems.
57. Work. All labor, materials and incidentals required to execute and complete the requirements of the Contract including superintendence, use of equipment and tools, and all services and responsibilities prescribed or implied.
58. Working Day. Any calendar day on which Contractor works or is expected to work in accordance with the approved work progress schedule.

1.02 WORK COVERED BY THE CONTRACT DOCUMENTS

- A. Intent of Contract and Contract Documents
  1. The intent of the Contract and Contract Documents is to describe a functionally complete project (or part

- thereof) to be constructed, and to provide for the construction and completion in every detail of the Work described therein.
2. The intent of the Contract is for Contractor to provide, at no additional cost to the County, all labor, documentation, services, materials, equipment, tools, transportation, and supplies that are:
    - a. Necessary to complete the Work in accordance with the Contract Documents.
    - b. Reasonably inferred and incidental to the Work, whether or not specifically called for by the Contract Documents.

B. Alteration of Plans or of Character of Work

1. Engineer reserves the right to make, at any time prior to or during the progress of the Work, such increases or decreases in quantities, whether a significant change or not, and such alterations in the details of construction, whether a substantial change or not, including but not limited to alterations in the grade or alignment of the road or structure or both, as may be found necessary or desirable by the Engineer. The term "significant change" applies only when the Engineer determines that the character of the work, as altered, differs materially from that involved or included in the original proposed construction.
2. Such increases, decreases or alterations shall not constitute a breach of Contract, shall not invalidate the Contract, nor release the Surety from any liability arising out of this Contract or the Surety bond. Contractor agrees to perform the work, as altered, the same as if it had been a part of the original Work.
3. The Department may require work that is not covered by a price in the Contract if the Department determines that such work does not constitute a significant change and is essential to the satisfactory completion of the Contract within its intended scope. If an adjustment in price is warranted, Engineer will determine the basis of payment for such an adjustment in a fair and equitable amount and authorize the adjustment through an executed Negotiated Acceptance Memorandum (NAM) provided by the Department.
4. In the instance of an alleged significant change, Engineer will review all pertinent information provided by Contractor to determine the validity of the allegation. The determination by Engineer shall be conclusive and shall not be subject to challenge by Contractor in any forum, except upon Contractor establishing by clear and convincing proof that the determination by Engineer was without any reasonable and good-faith basis.

C. Connections to Existing Pavement, Drives and Walks

1. Adhere to the limits of construction at the beginning and end of the Project as detailed in the Contract Documents. However, if Engineer determines that it is necessary to extend the construction in order to make suitable connections to existing pavement, Engineer will authorize such a change.

2. For necessary connections to existing pavement, walks and drives that are not indicated on the Plans, Engineer will provide direction regarding the proper connections in accordance with the applicable Standards.

D. Differing Site Conditions

1. During the progress of the Work, if subsurface or latent physical conditions are encountered at the site differing materially from those indicated in the Contract Documents, or if unknown physical conditions of an unusual nature differing materially from those ordinarily encountered and generally recognized as inherent in the work provided for in the Contract are encountered at the site, the party (County or Contractor) discovering such conditions shall promptly notify the other party in writing of the specific differing conditions before Contractor disturbs the conditions or performs the affected work.
2. Upon receipt of written notification of differing site conditions from Contractor, Engineer will investigate the conditions. If Engineer determines that the conditions materially differ and cause an increase or decrease in the cost or time required for the performance of any work under the Contract, an adjustment will be made, excluding loss of anticipated profits, and the Contract will be modified in writing accordingly. Engineer will notify Contractor whether or not an adjustment of the Contract is warranted.
3. Contractor shall not be entitled to any adjustment in the Contract Price or Contract Times if:
  - a. Contractor knew of the existence of such conditions at the time Contractor made a final commitment to the County with respect to Contract Price and Contract Times by the submission of a Bid; or
  - b. The existence of such condition could reasonably have been discovered or revealed as a result of any examination, investigation, exploration, test, or study of the Site and contiguous areas required by the Bidding Requirements or Contract Documents to be conducted by or for Contractor prior to Contractor's making a Bid; or
  - c. Contractor failed to give the written notice as required by this Article.
4. Engineer will not allow a Contract adjustment for a differing site condition unless Contractor has provided the required written notice.
5. Engineer will not allow a Contract adjustment under this clause for any effects caused to any other Department or non-Department projects on which Contractor may be working.

E. Underground Facilities.

1. It is generally recognized, and Contractor should anticipate that information provided by utility owners during project design, frequently fails to disclose all

Underground Facilities. The fact that more utility lines or other Underground Facilities are located in the Project Site than shown on the Project Plans does not constitute an unforeseen or differing Site Condition and such undisclosed Underground Facilities do not differ materially from the conditions which Contractor should expect.

2. Any information and data shown or indicated in the Contract Documents with respect to existing Underground Facilities at or contiguous to the Site is based on information and data furnished to the County design engineer by the owners of such Underground Utilities. Additional utilities may exist which are not shown in the Contract Documents. Unless it is otherwise expressly stated in the Special Provisions, the County is not responsible for the accuracy or completeness of any such information or data provided
3. Contractor is responsible for field verification and location of all Underground Facilities prior to the start of construction. No field work shall be allowed to start until Contractor has notified Sunshine State One-Call of Florida, Inc. and all affected utilities have been located. In addition, Contractor, without any additional compensation, must expose and physically locate all potentially conflicting Underground Facilities prior to construction and is fully responsible for:
  - a. Reviewing and checking all Underground Facilities information and data;
  - b. Locating and verifying all Underground Facilities at or contiguous to the Site;
  - c. Coordination of the Work with the owners of such Underground Facilities, including the County, during construction; and
  - d. The safety and protection of all such Underground Facilities and repairing any damage thereto resulting from the Work.
4. The actual locations of the Underground Facilities must be compared to locations shown on the Plans and any required changes in alignment and grade must be made at the time of construction in consultation with Engineer.
5. If an Underground Utilities is uncovered or revealed at or contiguous to the Site which was not shown or indicated, or not shown or indicated with reasonable accuracy in the Contract Documents:
  - a. Identify the owner of such Underground Facilities and give written notice to that owner and to Engineer promptly after becoming aware thereof and before further disturbing conditions affected thereby or performing any Work in connection therewith. During such time, Contractor shall be responsible for the safety and protection of such Underground Facility.
  - b. Engineer will promptly review the Underground Facilities and determine the extent, if any, to which a change is required in the Contract Documents to reflect and document the consequences of the existence or location of the Underground Facility. If

Engineer determines that the conditions materially differ and cause an increase or decrease in the cost or time required for the performance of the Work, an adjustment will be made, excluding loss of anticipated profits, and the Contract will be modified in writing accordingly. Engineer will notify Contractor whether or not an adjustment of the Contract is warranted.

F. Contractor Proposed Changes Affecting Utilities

1. Contractor is responsible for identifying and assessing any potential impacts to a utility that may be caused by the changes proposed by Contractor, and Contractor must, at the time of making the request for a change, notify the Department in writing of any such potential impacts to utilities.
2. Department approval of a Contractor proposed change does not relieve Contractor of sole responsibility for all utility impacts, costs, delays or damages, whether direct or indirect, resulting from Contractor initiated changes in the design or construction activities from those in the original Contract Specifications, design plans (including traffic control plans) or other Contract Documents and which effect a change in utility work different from that shown in the utility plans, joint project agreements or utility relocation schedules.

G. Rights in and Use of Materials Found on the Site of the Work

1. Ownership and Disposal of Existing Materials: Unless otherwise directed by Engineer or elsewhere in the Contract Documents, take ownership and dispose of all materials that are not designated as the property of other parties, in both roadway and structures, found on the right-of-way, and all material in structures designated for removal. Such materials do not include earth or other excavated material required for the construction of the Project. During construction, Contractor may use materials from existing structures that are required to be removed and that are designated to remain the property of the Department. Do not cut or otherwise damage such material during removal unless Engineer gives permission to do so. Store material in an accessible location as Engineer directs. The Department is not responsible for the quality or quantity of any material salvaged.
2. Ornamental Trees and Shrubs: Take ownership of all ornamental trees or shrubs existing in the right-of-way that are required to be removed for the construction operations and which are not specifically designated on the Plans to be reset, relocated, or to be removed by others prior to the construction operations.

H. Restoration of Property

1. Take preconstruction videos/pictures of the entire work zone and adjacent areas.
2. Public or private property damaged during construction or removed for convenience of the Work

must be repaired or replaced at Contractor's expense in a manner acceptable to Engineer, prior to final acceptance of the Work or sooner if otherwise required by the Contract Documents or Engineer. This includes, but is, not limited to signalization equipment and miscellaneous hardware removed from the construction site, signs, driveways, landscaping, sidewalk, walkways, walls, fences, footings, underground utilities, etc.

3. Contractor must comply with the requirements of Miami-Dade County Code Section 2-103.1 (b), CONSTRUCTION OF PUBLIC UTILITIES OR WORKS IN PUBLIC RIGHTS-OF-WAY

- a. "Whenever any person, corporation, partnership, association, County Department or other legal entity performs any construction or public work within an existing right-of-way located within unincorporated Miami-Dade County, or in right-of-ways of roads or streets located within municipalities that are maintained by the County, the right-of-way, including sidewalks, curbs and gutters, landscaping and must be restored to their legally permissible preexisting condition, including any aesthetic enhancements thereto and any adjacent private property damaged during construction, within thirty (30) days of completion of the construction or public work in that right of way or within thirty (30) days of damage to the affected property or area, whichever occurs first. Prior to the time such construction work begins, the contractor, by posting the construction site, shall inform the local community of the requirement to restore the right-of-way as well as any affected adjacent private property and the fines that could be imposed for each failure to do so. All work to be done pursuant to this Section shall be performed in compliance with the Public Works Manual. Any entity failing to restore the right-of-way to its preexisting condition or better within the time permitted shall be subject to a civil fine of five hundred dollars (\$500.00) per violation per day until such time as the right-of-way is restored, as well as five hundred dollars (\$500.00) per day for each affected adjacent private property until it is restored." Contractor may obtain a complete copy of the Ordinance from the Clerk of the Board.
- b. Post the construction site pursuant to Miami-Dade County Code Section 2-103 (b). The Public Notice to be posted is to read as follows:

**PUBLIC NOTICE**  
**ORDINANCE NO. 03-89**

*Contractor shall restore the right-of-way as well as any affected adjacent private property within 30 days of completion of construction or damage to the affected property or area, whichever occurs first.*

*Any entity failing to restore the right-of-way to its pre-existing condition or better within the time promoted shall be subject to a civil fine of \$500 per violation per day.*

4. Survey monuments.
  - a. Upon completion of construction activities and prior to the expiration of the Contract:
    - 1) Coordinate the replacement of any monument(s) disturbed or destroyed.
    - 2) Submit to Engineer for review and approval, a survey report that includes all monuments replaced and all monuments impacted as a result of construction activities.
  - b. The replacement of monuments and the preparation of the survey report must be by a licensed Florida Surveyor and Mapper and meet all applicable State Rules, Statutes, and requirements of the Department. All costs required for compliance with these requirements will be included among the Contract pay items.
5. Failure to Restore Damaged Property:
  - a. In case of failure on the part of Contractor to restore such property, bridge, road or street, or to make good such damage or injury, Engineer may, upon 48 hours notice, proceed to repair, rebuild, or otherwise restore such property, road, or street as may be deemed necessary, and the Department will deduct the cost thereof from any monies due or which may become due Contractor under the Contract. Nothing in this clause prevents the Contractor from receiving proper compensation for the removal, damage, or replacement of any public or private property, not shown on the plans, that is made necessary by alteration of grade or alignment. Engineer will authorize such work, provided that Contractor, or his employees or agents, have not, through their own fault, damaged such property.
6. Work Site Clean-Up:
  - a. Debris and trash shall be removed from the site daily. Mow turf or vegetation within the project limits in accordance with Article 107 of the Construction Specifications.
  - b. Upon completion of all work specified herein at each work site and before acceptance and

payment is made, Contractor shall remove from each work site all machinery, equipment, surplus and discarded materials, rubbish and temporary structures. Material cleared from site and deposited on adjacent property will not be considered as having been disposed of satisfactorily.

I. Final Cleaning Up of Right-of-Way

1. Upon completion of the Work, and before the Department accepts the Work and makes final payment, remove from the right-of-way and adjacent property all falsework, equipment, surplus and discarded materials, rubbish and temporary structures; restore in an acceptable manner all property, both public and private, that has been damaged during the prosecution of the work; and leave the waterways unobstructed and the roadway in a neat and presentable condition throughout the entire length of the work under Contract. Clean all areas impacted by the Work and remove sedimentation in drainage structures caused by the construction activities.
2. Do not dispose of materials of any character, rubbish or equipment, on abutting property, with or without the consent of the property owners. Engineer will allow Contractor to temporarily store equipment, surplus materials, usable forms, etc., on a well-kept site owned or leased by Contractor, adjacent to the Project. However, do not place or store discarded equipment, materials, or rubbish on such a site.
3. Shape, dress and restore areas adjacent to the Project right-of-way that were used as plant sites, materials storage areas or equipment yards when they are no longer needed for such purposes.

1.03 CONTROLLING WORK

A. Plans

1. Contract Documents: Have one complete copy of the Contract Documents available on the worksite at all times.
2. Department's Plans: Unless otherwise labeled, all Items shown on the Plans are considered to be part of the Work, and must be incorporated into the Work and included in the established prices.
3. Alterations in Plans: The Department will issue, in writing, all authorized alterations affecting the requirements and information given on the approved plans.

B. Typical Details and/or Sketches

1. Typical details and/or sketches regarding the proposed work may be provided in addition to the standard details that are available in the Miami-Dade County Public Works Manual and the latest edition of the Florida Department of Transportation's Design Standards for Design, Construction, Maintenance and Utility Operations on The State Highway System.



2. County through its Engineer shall have the right to modify the details and/or sketches, to supplement the sketches with additional plans and/or with additional information as work proceeds; all of which shall be considered as plans accompanying these Specifications herein generally referred to as the "Plans." In case of disagreement between the Plans and Specifications, Engineer will make a final determination as to which will govern.

C. Or-Equals and Substitutes

1. Except where specifically provided, whenever material or equipment is specified or described in the Contract Documents by proprietary name or as being available from a particular supplier, the intent is to establish the type, function, appearance, and quality required. A written request to Engineer to authorize an "or-equal" or "substitute" material or equipment may be submitted as described below unless the item specified or described contains or is followed by words reading that no like, equivalent, or "or-equal" item or no substitution is permitted.

a. Or-Equal Material or Equipment:

- 1) Material or equipment proposed by Contractor may be considered by Engineer as an "or equal" item if in Engineer's sole discretion the item proposed is functionally equal and sufficiently similar to that specified or described in the Contract Documents and that no change in related Work will be required.
- 2) Contractor has the burden of proving at Contractor's own cost and expense, to the satisfaction of Engineer, that the proposed item is equal to the named item. If Contractor fails to comply with the provisions of this Article, or if Engineer determines that the proposed item is not equal to that named, Contractor must supply the product named.
- 3) For the purposes of this Article and at Engineer's sole discretion, a proposed item of material or equipment will be considered functionally equal to the item specified or described in the Contract Documents if:
  - a) In the exercise of reasonable judgment Engineer determines that the proposed item is at least equal in materials of construction, quality, durability, appearance, strength, and design characteristics; will reliably perform at least equally well the function and achieve the results imposed by the design concept of the completed Project as a functioning whole; has a proven record of performance and availability of responsive service; and
  - b) Contractor certifies that, if approved and incorporated into the Work, there will be no increase in cost to the County or increase in Contract Times, and the proposed item will conform substantially

to the detailed requirements of the item named in the Contract Documents.

b. Substitute Material or Equipment:

- 1) If in Engineer's sole discretion an item of material or equipment proposed by Contractor does not qualify as an "or-equal" item, it may be proposed for consideration as a substitute item by Contractor submitting sufficient information as stipulated below to allow Engineer to determine that the item of material or equipment proposed is essentially equivalent to and an acceptable substitute for that named. Requirements pertaining to a proposed substitute item request for review by Engineer will be as set forth in this Article, as supplemented in the Contract Documents, and as Engineer may decide are appropriate under the circumstances.

- 2) Contractor must make written application to Engineer for review of a proposed substitute item of material or equipment that Contractor seeks to furnish or use. The application shall:

- a) Certify that the proposed substitute item will perform adequately the functions and achieve the results called for by the general design, be similar in substance to that specified, and be suited to the same use as that specified;
- b) State the extent, if any, to which the use of the proposed substitute item will prejudice Contractor's achievement of Substantial Completion on time; whether or not use of the proposed substitute item in the Work will require a change in any of the Contract Documents to adapt the design to the proposed substitute item; and whether or not incorporation or use of the proposed substitute item in connection with the Work is subject to payment of any license fee or royalty;
- c) Identify all variations of the proposed substitute item from that specified, and available engineering, sales, maintenance, repair, and replacement services;
- d) Contain an itemized estimate of all costs or credits that will result directly or indirectly from use of such substitute item, including costs of redesign and claims of other contractors affected by any resulting change.

2. Substitute Construction Methods or Procedures: If a specific means, method, technique, sequence, or procedure of construction is expressly required by the Contract Documents, Contractor may furnish or utilize a substitute means, method, technique, sequence, or procedure of construction approved by Engineer. For Engineer approval, submit sufficient information to allow Engineer, in Engineer's sole discretion, to determine that the substitute proposed is equivalent to that expressly called for by the Contract Documents. The requirements for review by Engineer will be as set

forth in this Article, as supplemented in the Contract Documents, and as Engineer may decide are appropriate under the circumstances.

3. Engineer's Evaluation: Engineer will be allowed a reasonable time within which to evaluate each proposal or submittal made pursuant to this Article and will be the sole judge of acceptability. Engineer may require Contractor to furnish additional data about the proposed substitute item. No "or equal" or substitute will be ordered, installed or utilized until Engineer's review is complete, which will be evidenced by receipt from Engineer of either a written approval or Change order where required for a substitute; or an approved Shop Drawing or written approval for an "or equal." Engineer will advise Contractor in writing of any negative determination. Contractor shall provide all data in support of any proposed substitute or "or-equal" at Contractor's expense. County may require Contractor to furnish at Contractor's expense a special performance guarantee or other surety with respect to any substitute item.
4. Engineer's Cost Reimbursement: Engineer will record Engineer's costs in evaluating a substitute proposed or submitted by Contractor pursuant to this Article whether or not Engineer approves a substitute item so proposed or submitted by Contractor, Contractor shall reimburse the County for the costs for evaluating each such proposed substitute. Contractor shall also reimburse the County for the costs of making changes in the Contract Documents from the acceptance of each proposed substitute.

D. Right Of Way Verification

1. All Work and improvements shall be performed, constructed and installed within the limits of the existing Right-of-Way pursuant to the Contract Documents.
2. Obtain all necessary documentation for verifying rights-of-way and property lines.
3. Retain a Florida Registered Surveyor and Mapper to obtain right-of-way and property lines by examining available rights-of-way maps, plats, occupation, legal descriptions or other legal documents or means. The Surveyor will layout the required alignments and grades and be responsible for their accuracy.
4. All field notes on this Project must be kept in a dedicated field book. Submit all field books to Engineer once the Project is completed or prior to completion when a field book gets filled.
5. All costs for complying with these requirements are included under the several scheduled items of the overall Contract. Therefore, no separate payment will be made for this work.

E. Shop Drawings

1. Shop Drawings:
  - a. General. Prepare and submit whatever detailed working drawings necessary to fabricate, erect, and construct all parts of the

Work in conformity with the Plans and Specifications. Shop drawings shall be submitted to Engineer; two sets will be returned to Contractor approved or showing the changes or corrections required; if changes or corrections are required, four revised copies shall be resubmitted until they are approved. Payment for shop drawings and required documents, revisions thereof, and for all copies furnished, shall be included in the various items of work bid. Contractor should allow a minimum of 14 days for the County's approval of shop drawings. County is not responsible for errors or minor discrepancies of Contractor's drawings, even though approved.

- b. Work Items Requiring Shop Drawings: In general, the Department requires shop drawings for items of work not fully detailed in the plans which require additional drawings and coordination prior to constructing the item, including but not limited to:
  - 1) Bridge components not fully detailed in the plans
  - 2) Retaining Wall Systems
  - 3) Precast Box Culverts
  - 4) Non-standard lighting, signalization and signing structures and components
  - 5) Building structures
  - 6) Drainage structures, attenuators, and other nonstructural items
  - 7) Design and structural details furnished by Contractor in compliance with the Contract
  - 8) Temporary Works affecting public safety.
- c. Schedule of Submittals: Prepare and submit a schedule of submittals that identifies the work for which shop drawings apply. For each planned submittal, define the type, and approximate number of drawings or other documents that are included and the planned submittal date, considering the processing requirements herein. Submit the schedule of submittals to Engineer at the preconstruction conference, and prior to the submission of any shop drawings. Coordinate subsequent submittals with construction schedules to allow sufficient time for review, approval, and re-submittal as necessary.
- d. Style, Numbering, and Material of Submittals:
  - 1) Drawings: Furnish four clearly legible copies of all shop drawings that are necessary to complete the structure in compliance with the design shown on the Plans. Prepare all shop drawings using the same units of measure as those used in the Plans. Use sheets no larger than 11 by 17 inches unless otherwise required by Engineer. Consecutively number each sheet in the submittal series, and indicate the total number in the series (i.e., 1

of 12, 2 of 12, . . . , 12 of 12). Include on each sheet the following items as a minimum requirement: the Project Number, Bridge Number(s), drawing title and number, a title block showing the names of the fabricator or producer and Contractor for which the work is being done, the initials of the person(s) responsible for the drawing, the date on which the drawing was prepared, the location of the item(s) within the Project, Contractor's approval stamp with date and initials, and, when applicable, the documents shall be signed and sealed by the Specialty Engineer or Contractor's Engineer of Record, as appropriate. A re-submittal will be requested when any of the required information is not included.

- 2) Other Documents: Provide four sets of original documents or clearly legible copies of documents other than drawings, such as trade literature, catalogue information, calculations, and manuals. Provide sheets no larger than 11 by 17 inches unless otherwise required by Engineer. Clearly label and number each sheet in the submittal to indicate the total number of sheets in the series (i.e., 1 of 12, 2 of 12, . . . , 12 of 12). Additional sets of documentation may be required by Engineer for review of precast prestressed and structural steel components.
- 3) Prepare all documents using the same units of measure as those used in the Contract Documents. Bind and submit all documents with a Table of Contents cover sheet. List on the cover sheet the total number of pages and appendices, and include the Project Number, a title referencing the submittal item(s), the name of the firm and person(s) responsible for the preparation of the document, Contractor's approval stamp with date and initials, and, when applicable, the documents shall be signed and sealed by the Specialty Engineer or Contractor's Engineer of Record, as appropriate.
- 4) Submit appropriately prepared and checked calculations and manuals that clearly outline the design criteria. Include on the internal sheets the Project Number and the initials of the person(s) responsible for preparing and checking the document.
- 5) Clearly label trade literature and catalogue information on the front cover with the title, Project Number, date and name of the firm and person(s) responsible for that document.

e. Submittal Paths and Copies:

- 1) General: Submit shop drawings to Engineer or Engineer's duly authorized representative. At the preconstruction conference, the Department will notify Contractor of any changes in the submittal path and whether the Department's or the Consultant's review stamp will signify an officially reviewed shop

drawing. When the Engineer of Record is a consultant hired by the Department, submit shop drawings to the consultant with a copy to Engineer. For work requiring other documentation (e.g., catalog data, procedure manuals, fabrication/welding procedures, and maintenance and operating manuals), submit the required number of copies with the prints. If not shown on the plans, the Department will furnish the mailing address of the Consulting Engineer of Record. Provide copies of material certifications and material tests to Engineer.

- 2) Contractor-Originated Design: Submit shop drawings and applicable calculations to the Engineer of Record for review. Ensure that each sheet of the shop drawings and the cover sheet of the calculations are signed and sealed by the Specialty Engineer or Contractor's Engineer of Record. Transmit the submittal and copies of the transmittal letters in accordance with the submittal requirements stipulated herein.
- 3) Temporary Works: For Construction Affecting Public Safety, submit to the Engineer of Record shop drawings and the applicable calculations for the design of special erection equipment, bracing, falsework, scaffolding, etc. Ensure that each sheet of the shop drawings and the cover sheet of the applicable calculations is signed and sealed by the Specialty Engineer. Transmit the submittal and copies of the transmittal letters in accordance with the submittal requirements stipulated herein.
- 4) Formwork and Scaffolding: Contractor is solely responsible for the safe installation and use of all formwork and scaffolding. The Department does not require any formwork or scaffolding submittals unless such work would be classified as Construction Affecting Public Safety or called for by the Contract Documents.
- 5) Beam and Girder Temporary Bracing: Contractor is solely responsible for ensuring stability of beams and girders during all handling, storage, shipping and erection. Adequately brace beams and girders to resist wind, weight of forms and other temporary loads, especially those eccentric to the vertical axis of the products, considering actual beam geometry and support conditions during all stages of erection and deck construction. Develop the required designs following the AASHTO Guide Design Specifications for Bridge Temporary Works and Construction Handbook for Bridge Temporary Works and the Contract Documents.
- 6) For Construction Affecting Public Safety, submit signed and sealed calculations for stability for all beams and girders.

- 7) Erection Plan: Submit, for Engineer's review, an Erection Plan that meets the specific requirements of FDOT Sections 450, 452 and 460 and this section. Refer to FDOT Design Standards Index 600 for construction activities not permitted over traffic.
  - 8) Other Miscellaneous Design and Structural Details Furnished by Contractor in Compliance with the Contract: Submit to Engineer any shop drawings and applicable calculations. Ensure that each sheet of the shop drawings and the cover sheet of the applicable calculations is signed and sealed by the Specialty Engineer. Transmit the submittal and copies of the transmittal letters in accordance with the submittal requirements stipulated herein.
- f. Processing of Shop Drawings:
- 1) Contractor Responsibility for Accuracy and Coordination of Shop Drawings:
    - a) Coordinate, schedule, and control all submittals, with a regard for the required priority, including those of the various subcontractors, suppliers, and engineers, to provide for an orderly and balanced distribution of the work.
    - b) Submit shop drawings to facilitate expeditious review. Contractor is discouraged from transmitting voluminous submittals of shop drawings at one time. For submittals transmitted in this manner, allow for the additional review time that may result.
    - c) Only shop drawings distributed that have been approved by the Department are valid. Any work that Contractor performs in advance of approval will be at Contractor's risk.
  - 2) Scope of Review by Engineer: The Engineer of Record's review of the shop drawings is for conformity to the requirements of the Contract Documents and to the intent of the design. The Engineer of Record's review of shop drawings which include means, methods, techniques, sequences, and construction procedures are limited to the effects on the permanent works. The Engineer of Record's review of submittals which include means, methods, techniques, sequences, and construction procedures does not include an in-depth check for the ability to perform the work in a safe or efficient manner. Review by the Engineer of Record does not relieve Contractor of responsibility for dimensional accuracy to ensure field fit and for conformity of the various components and details.
  - 3) Special Review by Engineer of Shop Drawings for Construction Affecting Public Safety: For Construction Affecting Public Safety, the Engineer of Record, or other Engineer as the Department appoints for this purpose, will make an independent review of all relevant shop drawings and similar documents. Do not proceed with construction of the permanent works until receiving the Engineer of Record's approval. The review of these shop drawings is for overall structural adequacy of the item to support the imposed loads and does not include a check for economy, efficiency or ease of construction.
- g. Other Requirements for Shop Drawings for Bridges:
- 1) Shop Drawings for Structural Steel and Miscellaneous Metals: Furnish shop drawings for structural steel and miscellaneous metals. Shop drawings shall consist of working, shop, and erection drawings, welding procedures, and other working plans, showing details, dimensions, sizes of material, and other information necessary for the complete fabrication and erection of the metal work.
  - 2) Shop Drawings for Concrete Structures: Furnish shop drawings for concrete components that are not cast-in-place and are not otherwise exempted from submittal requirements. Also, furnish shop drawings for all details that are required for the effective prosecution of the concrete work and are not included in the Contract Documents such as: special erection equipment, masonry layout diagrams, and diagrams for bending reinforcing steel, in addition to any details required for concrete components for the permanent work.
  - 3) Shop Drawings for Major and Unusual Structures: In addition to any other requirements, within 60 days from the Notice to Proceed, submit information to Engineer outlining the integration of the Major and Unusual Structure into the overall approach to the project. Where applicable to the project, include, but do not limit this information to:
    - a) The overall construction program for the duration of the Contract. Clearly show the Milestone dates.
    - b) The overall construction sequence. The order in which individual structures are to be built, the sequence in which individual spans of girders or cantilevers are erected, and the sequence in which spans are to be made continuous.
    - c) The general location of any physical obstacles to construction that might impose restraints or otherwise affect the construction, and an outline of how to deal with such obstacles while building the structure(s).
    - d) The approximate location of any special lifting equipment in relation to the structure, including clearances required for the operation of the equipment.

- e) The approximate location of any temporary falsework, and the conceptual outline of any special erection equipment. Provide the precise locations and details of attachments, fixing devices, loads, etc. in later detailed submittals.
- f) An outline of the handling, transportation, and storage of fabricated components, such as girders or concrete segments. Provide the precise details in later detailed submittals.
- g) Any other information pertinent to the proposed scheme or intended approach.
- h) Clearly and concisely present the above information on as few drawings as possible in order to provide an overall, integrated summary of the intended approach to the project. The Department will use these drawings for information, review planning, and to assess Contractor's approach in relation to the intent of the original design. The delivery to and receipt by Engineer does not constitute any Department acceptance or approval of the proposals shown thereon. Include the details of such proposals on subsequent detailed shop drawing submittals. Submit timely revisions and re-submittals for all variations from these overall scheme proposals.
- h. Cost of Shop Drawings: Include the cost of furnishing shop and working drawings in the Contract prices for the work requiring the shop and working drawings. The Department will not pay Contractor additional compensation for such drawings.

2. Certifications:

- a. Special Erection Equipment: Prior to its use, ensure that the Specialty Engineer personally inspects the special erection equipment and certifies to Engineer in writing that the equipment has been fabricated in accordance with the submitted drawings and calculations. In addition, after assembly, ensure that the Specialty Engineer observes the equipment in use and certifies to Engineer in writing that it is being used as intended and in accordance with the submitted drawings and calculations. In each case, ensure that the Specialty Engineer also signs and seals the letter of certification.
- b. Falsework and Shoring Requiring Shop Drawings: After its erection or installation but prior to the application of any superimposed load, ensure that the Specialty Engineer personally inspects the falsework and certifies to Engineer in writing that the falsework has been constructed in accordance with the materials and details shown on the submitted drawings and calculations. Ensure that the Specialty

Engineer also signs and seals the letter of certification.

- c. Temporary Formwork: For Construction Affecting Public Safety and for Major and Unusual Structures, prior to the placement of any concrete, ensure that the Specialty Engineer inspects the formwork and certifies to Engineer in writing that the formwork has been constructed to safely withstand the superimposed loads to which it will be subjected. Ensure that the Specialty Engineer signs and seals the letter of certification.
- d. Erection: For Construction Affecting Public Safety, submit an erection plan signed and sealed by the Specialty Engineer to Engineer at least four (4) weeks prior to erection commencing. Include as part of this submittal signed and sealed calculations and details for any falsework, bracing or other connection(s) supporting the structural elements shown in the erection plan.
- e. At least two (2) weeks prior to beginning erection, conduct a Preerection meeting with the Specialty Engineer and Engineer to review details of the plan.
- f. After erection of the elements but prior to opening of the roadway below the structure, ensure that a Specialty Engineer has personally inspected the erected member(s) and certified to Engineer that the structure has been erected in accordance with the signed and sealed erection plan.
- g. Perform daily inspections of the erected structural systems. For structures without temporary supports but with temporary girder bracing systems, perform inspections until all the diaphragms and cross frames are in place. For structures with temporary supports, perform inspections until the temporary supports are no longer needed as indicated in the erection plans. Provide written documentation of the inspections to Engineer within 24 hours of the inspection.

3. Corrections for Construction Errors:

- a. For work that Contractor constructs incorrectly or does not meet the requirements of the Contract Documents, Contractor has the prerogative to submit an acceptance proposal to Engineer for review and disposition. The acceptance proposal shall describe the error or defect and either describe remedial action for its correction or propose a method for its acceptance. In either case, the acceptance proposal shall address structural integrity, aesthetics, maintainability, and the effect on Contract Time. The Department will judge any such proposal for its effect on these criteria and also for its effect on Contract Administration.
- b. When Engineer judges that a proposal infringes on the structural integrity or maintainability of the structure, Contractor's

Engineer of Record will perform a technical assessment and submit it to Engineer for approval.

- c. Do not take any corrective action without Engineer's approval. Carry out all approved corrective construction measures at no expense to the County.
- d. Notwithstanding any disposition of the compensation aspects of the defective work, Engineer's decision on the technical merits of a proposal is final.

F. Coordination of Contract Documents

1. These Specifications, the Plans, Special Provisions, and all supplementary documents are integral parts of the Contract; a requirement occurring in one is as binding as though occurring in all.
2. All parts of the Contract Documents are complementary and describe and provide for a complete work. In addition to the work and materials specified in the Specifications as being included in any specific pay item, include in such pay items additional, incidental work, not specifically mentioned, when so shown in the plans, or if indicated, or obvious and apparent, as being necessary for the proper completion of the work under such pay item and not stipulated as being covered under other pay items.
3. Promptly notify Engineer in writing of any conflict, error, ambiguity, omission or discrepancy which Contractor may discover within the Contract Documents and obtain a written interpretation or clarification from Engineer before proceeding with any work affected thereby. The higher quality, greater quantity, more specific or restrictive, or more expensive requirement necessary and applicable to the completed Project, based on Engineer's interpretation, will take precedence. Engineer's written decision on the issue will be final and binding.

G. Conformity of Work with Contract Documents

1. Perform all work and furnish all materials in conformity with the lines, grades, cross-sections, dimensions, and material requirements, including tolerances, as specified in the Contract Documents.
2. In the event that Engineer finds that Contractor has used material or produced a finished product that is not in conformity with the Contract Documents, but that Contractor has produced reasonably acceptable work, Engineer will determine if the Department will accept the work. In this event, Engineer will document the basis of acceptance by Contract modification, which provides for an appropriate reduction in the Contract price for such work or materials included in the accepted work as deemed necessary to conform to the determination based on engineering judgment.
3. In the event that Engineer finds that Contractor has used material or produced a finished product that is not in conformity with the Contract Documents, and that Contractor has produced an inferior or unsatisfactory product, Contractor shall remove and

replace or otherwise correct the work or materials at no expense to the County.

4. For base and surface courses, the Department will allow the finished grade to vary as much as 0.1 foot from the grade shown in the plans, provided that Contractor's work meets all templates and straightedge requirements and contains suitable transitions.

H. Errors or Omissions in Contract Documents

1. Do not take advantage of any apparent error or omission discovered in the Contract Documents, but immediately notify Engineer of such discovery. Engineer will then make such corrections and interpretations as necessary to reflect the actual spirit and intent of the Contract Documents.

I. Authority of Engineer

1. Perform all work to the satisfaction of Engineer. Engineer will decide all questions, difficulties, and disputes, of whatever nature, that may arise relative to the interpretation of the Plans, construction, prosecution, and fulfillment of the Contract, and as to the character, quality, amount, and value of any work done, and materials furnished, under or by reason of the Contract.

J. Authority and Duties of Engineer's Assistants

1. Engineer's assistants and representatives are authorized to inspect all work done and all materials furnished. Such inspection may extend to all or any part of the work and to the manufacture, preparation, or fabrication of the materials to be used. Such assistants and representatives are not authorized to revoke, alter, or waive any requirement of these Specifications. Rather, they are authorized to call to the attention of Contractor any failure of the work or materials to meet the Contract Documents, and have the authority to reject materials or suspend the work until any questions at issue can be referred to and decided by Engineer.
2. Engineer will immediately notify Contractor in writing of any such suspension of the work, stating in detail the reasons for the suspension. The presence of the inspector or other assistant in no way lessens the responsibility of Contractor.

K. Engineering and Layout

1. Control Points Furnished by the Department:
  - a. Engineer will provide centerline control points (Begin Project, End Project, PIs, PTs, etc.) and bench marks at appropriate intervals along the line of the project to facilitate the proper layout of the work. Normally, Engineer will furnish only one bench mark for water crossings. Preserve all reference points and bench marks that the Department furnishes.

- b. As an exception to the above, for projects where the plans do not show a centerline or other survey control line for construction of the work (e.g. resurfacing, safety modifications, etc.) Engineer will provide only points marking the beginning and ending of the project, and all exceptions.
2. Furnishing of Stake Materials: Furnish all stakes, templates, and other materials necessary for establishing and maintaining the lines and grades necessary for control and construction of the Work.
  3. Layout of Work:
    - a. Utilizing the control points furnished by the Department, establish all horizontal and vertical controls necessary to construct the work in conformity to the Contract Documents. Perform all calculations required, and set all stakes needed such as grade stakes, offset stakes, reference point stakes, slope stakes, and other reference marks or points necessary to provide lines and grades for construction of all roadway, bridge, and miscellaneous items.
    - b. When performing utility construction as part of the project, establish all horizontal and vertical controls necessary to carry out such work.
  4. Specific Staking Requirements:
    - a. When performing new base construction as part of the Project, set stakes to establish lines and grades for subgrade, base, curb, and related items at intervals along the line of the work no greater than 50 feet on tangents and 25 feet on curves. Set grade stakes at locations that Engineer directs to facilitate checking of subgrade, base, and pavement elevations in crossovers, intersections, and irregular shaped areas.
    - b. For bridge construction stakes and other control, set references at sufficiently frequent intervals to ensure construction of all components of a structure in accordance with the lines and grades shown in the plans.
    - c. For projects where the plans do not show a centerline or other survey control line for construction of the work (resurfacing, safety modifications, etc.), provide only such stakes as necessary for horizontal and vertical control of work items.
    - d. For resurfacing and resurfacing-widening type projects, establish horizontal controls adequate to ensure that the asphalt mix added matches with the existing pavement. In tangent sections, set horizontal control points at 100 foot intervals by an instrument survey. In curve sections, set horizontal control points at 25 foot intervals by locating and referencing the centerline of the existing pavement.
    - e. Establish by an instrument survey, and mark on the surface of the finished pavement at 25 foot intervals, the points necessary for striping of the finished roadway. As an exception, for resurfacing and resurfacing/widening projects, establish these points in the same manner as used for horizontal control of paving operations. Mark the pavement with white paint. If performing striping, Engineer may approve an alternate method for layout of striping provided that Contractor achieves an alignment equal to or better than the alignment that would be achieved using an instrument survey.
  5. Personnel, Equipment, and Record Requirements:
    - a. Employ only competent personnel and use only suitable equipment in performing layout work. Do not engage the services of any person or persons, employed by the Department, for performance of layout work.
    - b. Keep adequate field notes and records while performing layout work. Make these field notes and records available for Engineer's review as the work progresses, and furnish copies to Engineer at the time of completion of the project. Engineer's inspection, checking, or acceptance of Contractor's field notes or layout work does not relieve Contractor of his responsibility to achieve the lines, grades, and dimensions shown in the Contract Documents.
    - c. Prior to final acceptance of the project, mark, in a permanent manner on the surface of the completed work, all horizontal control points originally furnished by the Department.
  6. Payment: Include the cost of performing layout work as described above in the Contract unit prices for the various items of work that require layout.

L. Contractor's Supervision

1. Contractor's Superintendent:

- a. Maintain a competent superintendent at the Site at all times while work is in progress to act as Contractor's agent. The superintendent must:
  - 1) Be capable of properly interpreting the Contract Documents and thoroughly experienced in the type of work being performed.
  - 2) Have full authority to receive instructions from Engineer and to execute the orders or directions of the Engineer, including promptly supplying any materials, tools, equipment, labor, and incidentals that may be required.
  - 3) Speak and understand English.
- b. Maintain at least one other responsible person who speaks and understands English, on the Project during all working hours.
- c. Furnish sufficient superintendence and supervisory personnel commensurate to the amount and type of work being performed.

2. Supervision for Emergencies:

- a. Provide a responsible person, who speaks and understands English, and who is available at or reasonably near the worksite on a 24 hour basis, seven days a week. Designate this person as the point of contact for emergencies and in cases that require immediate action to maintain traffic or to resolve any other problem that might arise.
- b. Submit, by certified mail, the phone numbers and names of personnel designated to be contacted in cases of emergencies, along with a description of the project location, to the Miami-Dade Police and all other local law enforcement agencies.

M. General Inspection Requirements

1. Cooperation by Contractor:

- a. Notify Engineer daily where each of his crews will be working and what work will be done. This notification shall be given each weekday between 3:00 p.m. and 4:00 p.m. on the prior day.
- b. Do not perform work or furnish materials without obtaining inspection by Engineer or his representative. Furnish Engineer with every reasonable facility for ascertaining whether the work performed and materials used are in accordance with the requirements and intent of the Contract Documents.
- c. If Engineer so requests at any time before final acceptance of the work, remove or uncover such portions of the finished work as

directed. After examination, restore the uncovered portions of the work to the standard required by the Contract Documents. If Engineer determines that the work so exposed or examined is unacceptable, perform the uncovering or removal, and the replacing of the covering or making good of the parts removed, at no expense to the County. However, if Engineer determines that the work thus exposed or examined is acceptable, the County will pay for the uncovering or removing, and the replacing of the covering or making good of the parts removed in accordance with the terms of the Contract Documents.

- 2. Failure of Engineer to Reject Work During Construction: If, during or prior to construction operations, Engineer fails to reject defective work or materials, whether from lack of discovery of such defect or for any other reason, such initial failure to reject in no way prevents the later rejection when such defect is discovered, or obligates the County to final acceptance. The County is not responsible for losses suffered due to any necessary removals or repairs of such defects.
- 3. Failure to Remove and Renew Defective Materials and Work: If Contractor fails or refuses to remove and renew any defective materials used or work performed, or to make any necessary repairs in an acceptable manner and in accordance with the requirements of the Contract within the time indicated in writing, the Engineer has the authority to repair, remove, or renew the unacceptable or defective materials or work as necessary, all at Contractor's expense. The Department will obtain payment for any expense it incurs in making these repairs, removals, or renewals, that Contractor fails or refuses to make, by deducting such expenses from any moneys due or which may become due Contractor, or by charging such amounts against the Contract bond.
- 4. Inspection by State and/or Federal Government: When the State of Florida and/or the United States Government pays a portion of the cost of construction, their representatives may inspect the construction work as they deem necessary. However, such inspection(s) will in no way make the State or the Federal Government a party to the Contract.

N. Final Inspection

- 1. Maintenance until Acceptance: Maintain all Work until Engineer has given final acceptance in accordance with the requirements of the Contract Documents.
- 2. Inspection for Acceptance:
  - a. Upon notification that all Contract Work, or all Contract Work on the portion of the Contract scheduled for acceptance, has been completed, Engineer will make an inspection for acceptance. The inspection will be made within seven days of the notification. If Engineer finds that all work has been satisfactorily completed, the Department will



consider such inspection as the final inspection. If any or all of the Work is found to be unsatisfactory, Engineer will detail the remedial work required to achieve acceptance. Immediately perform such remedial work. Subsequent inspections will be made on the remedial work until Engineer accepts all Work.

- b. Upon satisfactory completion of the Work, the Department will provide written notice of acceptance, either partial or final, to Contractor.
  - c. Until final acceptance in accordance with the requirements of the Contract Documents, replace or repair any damage to the accepted Work.
3. Partial Acceptance: At Engineer's sole discretion, Engineer may accept any portion of the Work under the provisions stipulated above.
4. Conditional Acceptance: Engineer will not make, or consider requests for conditional acceptance of a project.
- O. Final Acceptance.
- a. When, upon completion of the final construction inspection of the entire Project, Engineer determines that Contractor has satisfactorily completed all the Work and furnished all documents required by the Contract Documents, Engineer will give Contractor written notice of final acceptance. Final Acceptance shall also denote the beginning of any warranty periods associated with the Project.

#### 1.04 CONTROLLING MATERIALS

##### A. Acceptance Criteria

##### 1. General:

- a. All materials and equipment, except for materials specifically called for on the Contract Documents to be provided by the County, are to be supplied by the Contractor who must, as required, obtain shop drawing approvals and order these items in a timely fashion so as not to cause any delays in the approved schedule.
- b. Acceptance of materials is based on the criteria provided herein and elsewhere in the Contract Documents. All requirements may not apply to all materials. Use only materials in the Work that meet the requirements of the Contract Documents. Engineer may inspect and test any material, at points of production, distribution and use.

##### 2. Sampling and Testing:

- a. Use sample identification and tracking forms approved by Engineer to provide related information and attach the information to

each sample. Restore immediately any site from which material has been removed for sampling purposes to the pre-sampled condition with materials and construction methods used in the initial construction, at no additional cost to the County. Ensure that sufficient material is delivered to allow for proper sample collection, at no expense to the County.

##### b. Where required:

- 1) Pretest by Manufacturers: Submit certified manufacturer's test results to Engineer for qualification and use on the Project. Testing will be as specified in the Contract Documents. The Department may require submittal from manufacturers of samples of materials for independent verification purposes.
- 2) Point of Production Test: Test the material during production as specified in the Contract Documents.
- 3) Point of Distribution Test: Test the material at Distribution facilities as specified in the Contract Documents.
- 4) Point of Use Test: Test the material immediately following placement as specified in the Contract Documents. After delivery to the Project, the Department may require the retesting of materials that have been tested and accepted at the source of supply, or may require the testing of materials that are to be accepted by Producer Certification. The Department may reject all materials that, when retested, do not meet the requirements of the Contract Documents.

##### 3. Certification:

- a. Manufacturer Material Certification: Submit material certifications for all materials to Engineer for approval when required by the Specifications. Materials will not be considered for payment when not accompanied by a material certification. Sample material certification forms are available on the FDOT's website at the following URL: <http://www.fdot.gov/materials/navigation/documents.shtm>
- b. Ensure that the material certification follows the format of the sample form, is submitted on the manufacturer's letterhead and is signed by a legally responsible person employed by the manufacturer.
- c. FDOT Approved Product List (APL): The Department will limit Contractor's use of products and materials that require use of APL items to those listed on the APL effective at the time of placement.
- d. Traffic Signals and Signs (TSS) Division's Qualified Products List (TSSQPL):

- 1) Only those traffic control equipment and materials listed in the DTPW Traffic Signals and Signs (TSS) Division's Qualified Products List (TSSQPL), or submitted to and approved in writing by the DTPW TSS for addition to the TSSQPL, are allowed to be installed within Miami-Dade County. Equipment or material used in the performance of the Work, without prior Departmental approval, must be replaced with Department approved equipment or material, at no cost to the County. The TSSQPL is available at <http://www.miamidade.gov/qpl/Home.aspx>
  - e. Contractor Installation Certification: Provide installation certifications as required by the Contract Documents.
- B. Applicable Documented Authorities Other Than Specifications
1. General: Details on individual materials are identified in various material specific Sections of the Specifications that may refer to other documented authorities for requirements. When specified, meet the requirements as defined in such references.
  2. Test Methods: Methods of sampling and testing materials are in accordance with the Florida Methods (FM). If a Florida Method does not exist for a particular test, perform the testing in accordance with the method specified in the Specification. When test methods or other standards are referenced in the Specifications without identification of the specific time of issuance, use the most current issuance, including interims or addendums thereto, at the time of bid opening.
  3. Construction Aggregates:
    - a. Unless otherwise specified in the Contract Documents:
      - 1) All aggregate products and sources used in performance of the Work must be approved by FDOT pursuant to Rule 14-103, F.A.C. Aggregates and sources used must be identified in the FDOT "Approved Aggregate Products from Mines or Terminals" listings current at the time the aggregate is proposed for use on the Project.
      - 2) Each truck aggregate load ticket provided must include the DTPW Project Name and Number, name of the aggregate source, the FDOT Source Number, quantity, aggregate description and corresponding FDOT material code, producer ticket number, and statement "CERTIFIED FOR FDOT" or "CERT. FOR FDOT."
- C. Storage of Materials and Samples
1. Method of Storage: Store materials in such a manner as to preserve their quality and fitness for the work, to facilitate prompt inspection, and to minimize noise impacts on sensitive receivers. More detailed requirements concerning the storage of specific materials are prescribed under the applicable Specifications. The Department may reject improperly stored materials.
2. Use of Right-of-Way for Storage: Unless otherwise stated in the Contract Documents, no Project staging areas have been provided by the County. If Engineer allows, Contractor may use a portion of the right-of-way for temporary storage purposes and for temporarily placing Contractor's plant and equipment. Use only the portion of the right-of-way that is outside the clear zone, which is the portion not required for public vehicular or pedestrian travel. When used, restore the right-of-way to pre-construction condition at no additional cost to the County or as specified in the Contract Documents. Provide any additional space required at no expense to the County.
3. Responsibility for Stored Materials: Accept responsibility for the protection of stored materials. The Department is not liable for any loss of materials, by theft or otherwise, or for any damage to the stored materials.
4. Storage Facilities for Samples: Provide facilities for storage of samples as described in the Contract Documents and warranted by the test methods and Specifications.
- D. Defective Materials
1. Materials not meeting the requirements of the Contract Documents will be considered defective. Engineer will reject all such materials, whether in place or not. Remove all rejected material immediately from the site of the work and from storage areas, at no expense to the County.
  2. Do not use material that has been rejected and the defects corrected, until Engineer has approved the material's use. Upon failure to comply promptly with any order of Engineer made under these provisions, Engineer will remove and replace defective material and deduct the cost of removal and replacement from any moneys due or to become due to Contractor.
  3. As an exception to the above, Contractor may submit, upon approval of Engineer, an engineering and/or laboratory analysis to evaluate the effect of defective in-place materials. A Specialty Engineer, who is an independent consultant or Contractor's Engineer of Record as stated within each individual Section shall perform any such analysis. Engineer will determine the final disposition of the material after review of the information submitted by Contractor. No additional monetary compensation or time extension will be granted for the impact of any such analysis or review.
- E. Products and Source of Supply
1. Source of Supply—Convict Labor (Federal-Aid Contracts Only):
    - a. Do not use materials that were produced after July 1, 1991, by convict labor for Federal-aid highway construction projects

unless the prison facility has been producing convict-made materials for Federal-aid highway construction projects before July 1, 1987.

- b. Use materials that were produced prior to July 2, 1991, by convicts on Federal-aid highway construction projects free from the restrictions placed on the use of these materials by 23 U.S.C. 114. The Department will limit the use of materials produced by convict labor for use in Federal-aid highway construction projects to:
    - 1) Materials produced by convicts on parole, supervised release, or probation from a prison or,
    - 2) Materials produced in a qualified prison facility.
  - c. The amount of such materials produced for Federal-aid highway construction during any 12-month period shall not exceed the amount produced in such facility for use in such construction during the 12-month period ending July 1, 1987.
2. Buy American: Contractor must comply with the requirements of Miami Dade County Code, Section 2-8.2.6.1, Buy American Iron and Steel Products Procurement Program:
- a. The Buy American legislation requires that iron and steel products utilized in certain Miami-Dade County public improvement projects be produced in the United States. This requirement shall not apply if:
    - 1) The project is federal funded.
    - 2) iron and steel products are not produced in the United States in sufficient and reasonably available quantities or of a satisfactory quality; or
    - 3) upon a written recommendation of the County Mayor approved by a majority vote of the Board members present, compliance with this requirement is not consistent with the best interests of the public.
3. Source of Supply-Steel (Federal-Aid Contracts Only):
- a. For Federal-aid Contracts, only use steel and iron produced in the United States, in accordance with the Buy America provisions of 23 CFR 635.410, as amended. Ensure that all manufacturing processes for this material occur in the United States. As used in this specification, a manufacturing process is any process that modifies the chemical content, physical shape or size, or final finish of a product, beginning with the initial melting and mixing and continuing through the final shaping and coating. A manufactured steel or iron product is complete only when all grinding, drilling, welding, finishing and coating have been completed. If a domestic product is taken outside the United States for any process, it becomes foreign source

material. When using steel and iron as a component of any manufactured product incorporated into the project (e.g., concrete pipe, prestressed beams, corrugated steel pipe, etc.), these same provisions apply, except that the manufacturer may use minimal quantities of foreign steel and iron when the cost of such foreign materials does not exceed 0.1% of the total Contract amount or \$2,500, whichever is greater.

- b. These requirements are applicable to all steel and iron materials incorporated into the finished work, but are not applicable to steel and iron items that Contractor uses but does not incorporate into the finished work. Provide a certification from the manufactures of steel or iron, or any product containing steel or iron as a component, stating that all steel or iron furnished or incorporated into the furnished product was produced and manufactured in the United States in accordance with the requirements of this specification and the Buy America provisions of 23 CFR 635.410, as amended. Such certification shall also include (1) a statement that the product was produced entirely within the United States, or (2) a statement that the product was produced within the United States except for minimal quantities of foreign steel and iron valued at \$ (actual cost). Submit each such certification to Engineer prior to incorporating the material into the project. When FHWA allows the use of foreign steel on a project, submit invoices to document the cost of such material, and obtain Engineer's written approval prior to incorporating the material into the project.

4. Contaminated Unfit, Hazardous, and Dangerous Materials:
- a. Do not use any material that, after approval and/or placement, has in any way become unfit for use.
  - b. Do not use materials containing any substance that has been determined to be hazardous by the State of Florida Department of Environmental Protection or the U.S. Environmental Protection Agency (EPA). Provide workplaces free from serious recognized hazards and to comply with occupational safety and health standards, as determined by the U.S. Department of Labor Occupational Safety and Health Administration (OSHA).

1.05 LEGAL REQUIREMENTS AND RESPONSIBILITY TO THE PUBLIC

A. Disaster Preparedness

1. General:

- a. During periods in which any portion of Miami-Dade County is designated by the National Oceanic and Atmospheric Administration's

National Hurricane Center as being under a Tropical Storm Watch or greater, Contractor shall perform all precautions as necessary to safeguard the Work and property, including the removal of all small equipment and materials from the site, securing all other equipment and materials to each other and to rigid construction, and any other safety measures as may be directed by Engineer.

2. Upon Notification of a Tropical Storm or Hurricane Watch:
  - a. Engineer will provide formal notification to Contractor to prepare and submit for approval a Plan of Action for the specific actions to be taken on their particular projects.
3. Upon Notification of a Tropical Storm or Hurricane Warning:
  - a. Engineer will provide formal notification to Contractor to implement the approved Plan of Action to protect the Project and the public.
  - b. For construction projects within the public right-of-way, Contractor will be notified by Engineer to suspend his construction operations. Contractor will backfill all open trenches, remove all construction equipment and materials from the right-of-way, remove unnecessary traffic barricades and signs, and secure remaining barricades by "half burial" or "double sand bags."
4. Storm or Disaster Services:
  - a. Contractor, by accepting the award of this Contract, recognizes and agrees that should a storm or other severe and catastrophic natural disaster affect the Miami-Dade-County area during the performance of the work, Contractor shall provide services contracted for during the contract period, at the Contract unit prices and at the same or different locations from those covered by this Contract.
  - b. For emergency services and conditions not addressed by this Contract, Contractor agrees to negotiate reasonable prices and terms with the County for any disaster-relief work required by the County. In all instances, Contractor agrees to negotiate reasonable time extensions for performance of disaster-relief work.

**B. Laws to be Observed**

1. General:
  - a. Become familiar with and comply with all applicable Federal, State, County, and city laws, by-laws, ordinances, and regulations that control the action or operation of those engaged or employed in the Work or that affect materials used. Pay particular attention to the applicable safety regulations promulgated by the U.S. Department of

Labor, Occupational Safety and Health Administration (OSHA). In addition, comply with Chapter 403, F.S. (Florida Statutes), regarding control of air pollution. Direct special attention to that portion of Chapter 17-5, F.A.C. (Florida Administrative Code), pertaining to open burning in land clearing operations. Where work or structures included in the Contract are in "Navigable Waters of the U.S.," (reference 33 of the Code of Federal Regulations, Part 329); "Waters of the U.S.," (reference 33 of the Code of Federal Regulations, Parts 323 and 328); or "Waters of the State," (reference Part 4, Chapters 253 and 373 of the Florida Statutes and Section 62-340, F.A.C.); comply with the regulatory provisions of Section 404 of the Federal Clean Water Act of 1977; Sections 9 and 10 of the Federal River and Harbor Act of 1899; Chapter 161, F.S.; and any local authority having jurisdiction over such waters.

- b. Obtain certification from the Construction Industry Licensing Board as required by Part I, Chapter 489, F.S., regardless of exemptions allowed by Section 489.103, F.S., prior to removing underground pollutant storage tanks. Dispose of tanks and pollutants in accordance with the requirements and regulations of any Federal, State, or local, agency having jurisdiction.
  - c. Prior to building construction or renovation, provide copies of current registrations or certifications issued by the Florida Construction Industry Licensing Board in accordance with Chapter 489, F.S. for the appropriate category of construction.
  - d. Corporations must be registered with the State of Florida, Department of State, Division of Corporations, and hold a current State Corporate Charter Number in accordance with Chapter 607, F.S.
  - e. Contractor or the authorized subcontractor applying any roofing material must be licensed or be an approved dealer and applicator of the proposed roofing material.
  - f. Indemnify, defend, and save harmless the County and all of its officers, agents, and employees, in the amount of the Contract price, against all claims or liability arising from or based on the violation of any such laws, by-laws, ordinances, regulations, order, or decrees; whether by himself or his employees.
2. Plant Quarantine Regulations: The U.S. Department of Agriculture and the Florida Department of Agriculture and Consumer Services have issued quarantine regulations pertaining to control of the nematodes of citrus, Rule 5B-44, Florida Administrative Code, and other plant pests. Contact the local (or other available) representatives of the Animal and Plant Health Inspection Service of the U.S. Department of Agriculture, and the Division of Plant Industry of the Florida Department of Agriculture and Consumer

Services to ascertain all current restrictions regarding plant pests that are imposed by these agencies. Keep advised of current quarantine boundary lines throughout the construction period.

- a. These restrictions may affect operations in connection with such items as clearing and grubbing, earthwork, grassing and mulching, sodding, landscaping, and other items which might involve the movement of materials containing plant pests across quarantine lines.
- b. Obtain quarantine regulations and related information from the following:

Animal and Plant Health Inspection Service  
U.S. Department of Agriculture  
3029 Lake Alfred Road  
Winter Haven, Florida 33881

Director, Division of Plant Industry  
Florida Department of Agriculture and Consumer Services  
Post Office Box 147100  
Gainesville, Florida 32614-7100

3. Introduction or Release of Prohibited Aquatic Plants, Plant Pests, or Noxious Weeds:

- a. Do not introduce or release prohibited aquatic plants, plant pests, or noxious weeds into the project limits as a result of clearing and grubbing, earthwork, grassing and mulching, sodding, landscaping, or other such activities. Immediately notify Engineer upon discovery of all prohibited aquatic plants, plant pests, or noxious weeds within the project limits. Do not move prohibited aquatic plants, plant pests, or noxious weeds within the project limits or to locations outside of the project limits without Engineer's permission. Maintain all borrow material brought onto the project site free of prohibited aquatic plants, plant pests, noxious weeds, and their reproductive parts. Refer to Rule 16C-52 and Rule 5B-57, F.A.C. for the definition of prohibited aquatic plants, plant pests, and noxious weeds.
- b. Furnish Engineer, prior to incorporation into the Project, with a certification from the Florida Department of Agriculture and Consumer Services, Division of Plant Industry, stating that the sod, hay, straw, and mulch materials are free of noxious weeds, including Tropical Soda Apple.

4. Compliance with Federal Endangered Species Act and other Wildlife Regulations:

- a. The Federal Endangered Species Act requires that the Department investigate the potential impact to a threatened or endangered species prior to initiating an activity performed in conjunction with a highway construction project. If the Department's investigation determines that there is a potential impact to a protected, threatened or an endangered species, the

Department will conduct an evaluation to determine what measures may be necessary to mitigate such impact. When mitigation measures and/or special conditions are necessary, these measures and conditions will be addressed in the Contract Documents or in permits as identified in 7-2.1.

- b. In addition, in cases where certain protected, threatened or endangered species are found or appear within close proximity to the project boundaries, the Department has established guidelines that will apply when interaction with certain species occurs, absent of any special mitigation measures or permit conditions otherwise identified for the project. These guidelines are posted at the following URL address:  
[https://fdotwww.blob.core.windows.net/sitefinity/docs/defaultsource/programmanagement/implemented/urlinspecs/files/endangeredwildlifeguidelines.pdf?sfvrsn=e27baf3f\\_2](https://fdotwww.blob.core.windows.net/sitefinity/docs/defaultsource/programmanagement/implemented/urlinspecs/files/endangeredwildlifeguidelines.pdf?sfvrsn=e27baf3f_2).

Take responsibility to obtain this information and take all actions and precautions necessary to comply with the conditions of these guidelines during all project activities.

- c. Prior to establishing any off-project activity in conjunction with a project, notify the Engineer of the proposed activity. Covered activities include but are not necessarily limited to borrow pits, concrete or asphalt plant sites, disposal sites, field offices, and material or equipment storage sites. Include in the notification the Financial Project ID, a description of the activity, the location of the site by township, range, section, county, and city, a site location map including the access route, the name of the property owner, and a person to contact to arrange a site inspection. Submit this notification at least 30 days in advance of planned commencement of the off-site activity, to allow for the Department to conduct an investigation without delaying job progress.
- d. Do not perform any off-project activity without obtaining written clearance from the Engineer. In the event the Department's investigation determines a potential impact to a protected, threatened or endangered species and mitigation measures or permits are necessary, coordinate with the appropriate resource agencies for clearance, obtain permits and perform mitigation measures as necessary. Immediately notify the Engineer in writing of the results of this coordination with the appropriate resource agencies. Additional compensation or time will not be allowed for permitting or mitigation, associated with Contractor initiated off-project activities.

5. Occupational Safety and Health Requirements: Contractor shall take all precautions necessary for the protection of life, health, and general occupational welfare of all persons, including employees of both

- Contractor and the County, until Contractor has completed the work required under the Contract. Comply at all times with applicable Federal, State, and local laws, provisions, and policies governing safety and health, including 29 CFR 1926, including all subsequent revisions and updates.
6. Discovery of an Unmarked Human Burial: When an unmarked human burial is discovered, immediately cease all activity that may disturb the unmarked human burial and notify Engineer. Do not resume activity until specifically authorized by Engineer.
  7. Insecticides and Herbicides: Use products approved by the Florida Department of Agriculture for the State of Florida, found on the following website <http://state.ceris.purdue.edu/>. The use of restricted products is prohibited. Do not use any products in the sulfonyleurea family of chemicals. Herbicide application by broadcast spraying is not allowed.
    - a. Procure any necessary licenses, pay all charges and fees, and give all notices necessary for lawful performance of the work.
    - b. Ensure that all employees applying insecticides and herbicides possess a current Florida Department of Agriculture Commercial Applicator license with the categories of licensure in Right-of-Way Pest Control and Aquatic Pest Control. Provide a copy of current certificates upon request, to Engineer.
    - c. Ensure that employees who work with herbicides comply with all applicable Federal, State, and local regulations.
    - d. Comply with all regulations and permits issued by any regulatory agency within whose jurisdiction work is being performed. Post all permit placards in a protected, conspicuous location at the work site.
    - e. Acquire any permits required for work performed on the rights-of-way within the jurisdiction of National Forests in Florida. Contact the Local National Forest Ranger District, or the United States Department of Agriculture (USDA) office for the proper permits and subsequent approval.
    - f. Acquire all permits required for aquatic plant control as outlined in Chapter 62C-20, F.A.C., Rules of the Florida Department of Environmental Protection. Contact the Regional Field Office of Bureau of Invasive Plant Management of the Florida Department of Environmental Protection for proper permits and subsequent approval. If application of synthetic organo-auxin herbicides is necessary, meet the requirements of Chapter 5E-2, F.A.C.
    - g. Fertilizer: Ensure that all employees applying fertilizer, possess a current Florida Department of Agriculture and Consumer Services Commercial Applicator license in accordance with Section 482.1562, F.S. Upon request, submit the current certificates to the Engineer.
  8. Compliance with Section 4(f) of the USDOT Act: (Staging Areas)
    - a. Section 4(f) of the USDOT Act prohibits the U. S. Secretary of Transportation from approving a project which requires the use of publicly owned land of a public park, recreation area or a wildlife and waterfowl refuge, or of any historic site of national, state, or local significance unless there is no prudent or feasible alternative to using that land and the program or project includes all possible planning to minimize the harm to the site resulting from the use.
    - b. Before undertaking any off-project activity associated with any federally assisted undertaking, ensure that the proposed site does not represent a public park, recreation area, wildlife or waterfowl refuge, or a historic site (according to the results of the Cultural Resources Survey discussed under FDOT 120-6.2). If such a site is proposed, notify the Engineer and provide a description of the proposed off-site activity, the location of the site by township, range, section, a county or city map showing the site location, including the access route and the name of the property. It is the Contractor's responsibility to submit justification for use of Section 4(f) property that is sufficient for the Florida Department of Transportation and the Federal Highway Administration to make a Section 4(f) determination. Submit this notification sufficiently in advance of planned commencement of the off-site activity to allow a reasonable time for the Engineer to conduct an investigation without delaying job progress. Do not begin any off-project activity without obtaining written clearance from the Engineer
  9. Employment Eligibility Verification
    - a. By entering into this Contract, the Contractor affirms its enrollment and participation in the Federal work authorization program known as "E-Verify", web address <https://www.e-verify.gov/> operated by the United States Citizenship and Immigration Services Bureau of the United States Department of Homeland Security, to verify information under the terms governing use of the system.
    - b. The Contractor shall utilize the U.S. Department of Homeland Security's E-Verify system and retain the I-9 Forms for inspection, in accordance with the terms governing use of the system, to confirm the employment eligibility of all persons employed by the Contractor during the term of the Contract to perform employment duties within Florida; and all persons, including subcontractors, assigned by the Contractor to perform work pursuant to the Contract.
    - c. Contractor shall also be responsible for entering into an agreement, with each and every vendor and subcontractor, that states

that the vendor or subcontractor (and their vendors) is independently responsible for its own employment decisions, including hiring, disciplinary and termination decisions; and is participating in the "E-Verify" program to confirm, under the terms governing use of the system, the employment eligibility of all persons assigned to perform work or provide materials and services in support of this Contract.

- d. As per Florida Statute, Section 448.095, title "Verification of Employment Eligibility," Contractor and all Subcontractors must provide an affidavit attesting that the Subcontractor does not employ, contract with, or subcontract with, an unauthorized alien. Failure to comply may lead to termination of this contract, or if a Subcontractor knowingly violates the statute, the subcontract must be terminated immediately. Any challenge to termination under this provision must be filed in the Circuit Court no later than twenty (20) calendar days after the date of termination. If this Contract is terminated for a violation of the statute by the Contractor, the Contractor may not be awarded a public contract for a period of one year after the date of termination, and the Contractor may be liable for any additional costs incurred by the County resulting from the termination of the Contract
- e. Miami-Dade County reserves the right, at any time, to request supporting documentation, as evidence of services provided and demonstration of compliance with the above requirements.

### C. Permits and Licenses

#### 1. General:

- a. Except for permits procured by the Department, as incorporated by Special Provision to this Contract, if any, procure all permits and licenses, pay all charges and fees, and give all notices necessary and incidental to the due and lawful prosecution of the Work.
- b. The Department will also acquire any modifications or revisions to an original permit incorporated by Special Provision to this Contract when Contractor requires such modifications or revisions to complete the construction operations specified in the Plans or Special Provisions and within the right-of-way limits.
- c. Contractor must obtain all other permits required for this Project prior to commencing the Work. This includes permits required by other municipalities and agencies, permits to work in the Right-of-Way, and those required for the removal or relocation of trees.

- d. The actual amount paid for the permits will be reimbursed to Contractor from a dedicated allowance established by the County. If no dedicated allowance is specified the reimbursement shall be paid from the Contract's Contingency Allowance. Original receipts must be presented to Engineer for approval.
- e. Contractor must give all notices, pay all fees and comply with all laws, rules and regulations applicable to the Work at no additional cost.
- f. Acquire all permits for work performed outside the right-of-way or easements for the Project.
- g. In carrying out the work in the Contract, when under the jurisdiction of any environmental regulatory agency, comply with all regulations issued by such agencies and with all general, special, and particular conditions relating to construction activities of all permits issued to the Department as though such conditions were issued to Contractor. Post all permit placards in a protected location at the worksite.
- h. In case of a discrepancy between any permit condition and other Contract Documents, the more stringent condition shall prevail.

#### 2. Additional Contractor Requirements For Work With Traffic Control Devices or Street Lighting

- a. In addition to the license(s) required of Contractor, all personnel engaged in installing, modifying, repairing, removing or maintaining: roadway street lighting systems; traffic signalization; or any other electrical/electronic traffic control device in Miami-Dade County must:
  - 1) Perform work under the direction of a Master Electrician that is present at the job site or able to respond within 2 hours of notification (4 hours for roadway street lighting systems).
  - 2) Perform all work under the direct supervision of a Journeyman Electrician. For Traffic Signalization or Control Devices the Journeyman Electrician must be certified as an International Municipal Signal Association (IMSA) certified Traffic Signal Technician (TST) Level II or Level III. All work related at or pertaining to the controller must be performed by an IMSA certified TST Level II (Field).
  - 3) Have in their possession a wallet size card or a photocopy of their certifications and licenses. Failure to provide said documents will be cause for removal of employee from the work site, issuance of citations, and shutdown of the Work by the County.
- b. At the Preconstruction Conference, provide Engineer and the DTPW, Traffic Signal & Signs Division (7100 NW 36 Street, Miami, FL 33166) a signed affidavit affirming that the

- personnel performing the work described herein have all proper and valid licenses and certifications (County, State, Private or other Government Agency) required to perform the Work. Attach a list of employees assigned to this Project with a description of their duties and include copies of all of the required licenses and certifications for the Contractor and personnel performing the Work. Changes to authorized personnel must be approved by the Engineer.
- c. Provide copies of renewed licenses and certifications prior to their expiration.
3. Work or Structures in Navigable Waters of the U.S., Waters of the U.S., and Waters of the State:
    - a. In general, one or more governmental agencies will exercise regulatory authority over work or structures, including related construction operations, in all tidal areas (Channelward of the mean high water lines); in the ocean and gulf waters to the outer limits of the continental shelf; in all rivers, streams, and lakes to the ordinary high water line; in marshes and shallows that are periodically inundated and normally characterized by aquatic vegetation capable of growth and reproduction; in all artificially created channels and canals used for recreational, navigational, or other purposes that are connected to navigable waters; and in all tributaries of navigable waters up to their headwaters.
    - b. Whenever the work under or incidental to the Contract requires structures or dredge/fill/construction activities in "Navigable Waters of the U.S.," "Waters of the U.S.," and "Waters of the State," the Federal, State, county, and local regulatory agencies may require the Department to obtain a permit. For such dredge/fill /construction specified in the plans to be accomplished within the limits of the project, or for any dredge/fill/construction within the limits of Department-furnished borrow areas, the Department will procure the necessary permits prior to advertising for bids.
- D. Patented Devices, Materials and Processes
    1. Include all royalties and costs arising from patents, trademarks, and copyrights, in any way involved in the work in the Contract price. Whenever using any design, device, material, or process covered by letters patent or copyright, obtain the right for such use by suitable legal agreement with the patentee or owner of the copyright. File a copy of such agreement with Engineer. However, whether or not such agreement is made or filed as noted, Contractor and the surety in all cases shall indemnify, defend, and save harmless, the County from all claims for infringement by reason of the use of any such patented design, device, material, or process on work under the Contract, and shall indemnify the County for all costs, expenses, and damages that it may be obliged to pay by reason of any such infringement, at any time during the prosecution or after the completion of the Work.
- E. Right-of-Way Furnished by the Department
    1. Except as otherwise stipulated in these Specifications or as shown in the Plans, the Department will furnish all rights-of-way necessary for the proper completion of the Work at no expense to Contractor.
  - F. Sanitary Provisions
    1. Contractor shall provide and maintain, in a neat and sanitary condition, such accommodations for the use of his employees as are necessary to comply with the requirements and regulations of the State and local boards of health. Commit no public nuisance.
  - G. Control of Contractor's Equipment
    1. Traffic Interference: Do not allow equipment, while it is on or traversing a road or street, to unreasonably interfere with traffic.
    2. Overloaded Equipment: Do not operate on any road or street any hauling unit or equipment loaded in excess of (1) the maximum weights specified in the Florida Uniform Traffic Control Law, or (2) lower weights legally established for any section of road or bridge by the State, the Department, or local authorities. The governmental unit having jurisdiction over a particular road or bridge may provide exceptions by special permit under the provisions provided below for Crossings. This restriction applies to all roads and bridges inside and outside the Contract limits as long as these roads and bridges are open for public use. Contractor may overload roads and bridges which are to be demolished after they are permanently closed to the public. Contractor is responsible for all loss or damages resulting from equipment operated on a structure permanently closed to the public.
    3. Crossings: Where it is necessary to cross an existing road or street, including specifically the existing traveled lanes of a divided highway within the limits of the Project, obtain permits from the Municipality, the Department or FDOT depending on the location, for crossing overloaded or oversized equipment. Cross existing roads or streets only at Engineer-designated points. Engineer may require Contractor to protect the pavement or Roadway at the crossing by using lumber, planks, or fill. Provide flagging and watchman service, or approved signal devices, for the protection of traffic at all such crossings, in accordance with an approved written plan for that activity.
    4. Protection from Damage by Tractor-Type Equipment: Take positive measures to ensure that tractor-type equipment does not damage the road. If any such damage should occur, repair it without delay, at no expense to the County and subject to Engineer's approval.
  - H. Contractor's Equipment on Bridge Structures



1. The Specialty Engineer shall determine the effect that equipment loads have on the bridge structure and develop the procedures for using the loaded equipment without exceeding the structure's design load capacity.
  2. A completed bridge structure is a bridge structure in which all elemental components comprising the load carrying assembly have been completed, assembled, and connected in their final position. The components to be considered shall also include any related members transferring load to any bridge structure.
  3. The Specialty Engineer shall analyze the effect of imposed loads on bridge structures, within the limits of a construction contract, resulting from the following operations:
    - a. Overloaded Equipment as defined above operating on or crossing over completed or partially completed bridge structures.
    - b. Equipment within legal load limits operating on or crossing over partially completed bridge structures.
    - c. Construction cranes operating on completed or partially completed bridge structures.
  4. Submit to the Department for approval three copies of design calculations, layout drawings, and erection drawings showing how the equipment is to be used so that the bridge structure will not be overstressed. The Specialty Engineer shall sign and seal one set of the three copies of the drawings and the cover sheet of one of the three copies of the calculations for the Department's Record Set.
  5. Any pipe culvert(s) or box culvert(s) qualifying as a bridge by definition is excluded from the requirements above.
  6. Posting of the Legal Gross Vehicular Weight: Display the maximum legal gross weight, as specified in the Florida Uniform Traffic Code, in a permanent manner on each side of any dump truck or dump type tractor-trailer unit hauling embankment material, construction aggregates, road base material, or hot bituminous mixture to the project over any public road or street. Display the weight in a location clearly visible to the scale operator, in numbers that contrast in color with the background and that are readily visible and readable from a distance of 50 feet.
- I. Structures over Navigable Waters
1. Compliance with Federal and Other Regulations:
    - a. Where erecting structures in, adjacent to, or over, navigable waters, observe all regulations and instructions of Federal and other authorities having control over such waters. Do not obstruct navigation channels without permission from the proper authority, and provide and maintain navigation lights and signals in accordance with the Federal requirements for the protection of the structure, of false work, and of navigation.
      - b. In the event of accidental blocking of the navigation channel, immediately notify the U.S. Coast Guard of the blockage and upon removal of the blockage.
      - c. When work platforms are indicated in the permit for construction, submit work platform construction plans to the appropriate Coast Guard District for approval. Obtain approval prior to beginning construction on the platform.
2. Maintenance of Channel: Where the work includes the excavation of a channel or other underwater areas to a required section, maintain the section from shoaling or other encroachment until final acceptance of the project.
- J. Manatee Protection
1. This Subarticle applies to work in tidal waters, major canals, bodies of water where manatees have been recently spotted, or where required by any regulatory permit applicable to this Project:
    - a. Instruct all personnel associated with the Project about the presence of manatees and manatee speed zones, and the need to avoid collisions with and injury to manatees. Advise all construction personnel that there are civil and criminal penalties for harming, harassing, or killing manatees which are protected under the Marine Mammal Protection Act, the Endangered Species Act, and the Florida Manatee Sanctuary Act.
    - b. Operate all vessels associated with the construction project at "Idle Speed/No Wake" at all times while in the immediate area and while in water where the draft of the vessel provides less than a four-foot clearance from the bottom. All vessels will follow routes of deep water whenever possible.
    - c. Properly secure and regularly monitored all siltation or turbidity barriers to avoid manatee entanglement or entrapment. Barriers must not impede manatee movement. Siltation or turbidity barriers must be made of material in which manatees cannot become entangled.
    - d. All on-site project personnel are responsible for observing water-related activities for the presence of manatee(s). All in-water operations, including vessels, must be shut down if a manatee(s) comes within 50 feet of the operation. Activities will not resume until the manatee(s) has moved beyond the 50-foot radius of the project operation, or until 30 minutes elapses if the manatee(s) has not reappeared within 50 feet of the operation. Animals must not be herded away or harassed into leaving.
    - e. Report any collision with or injury to a manatee immediately to the FWC Hotline at 1-888-404-3922. In addition, report collision and/or injury to the U.S. Fish and Wildlife Service in Vero Beach (1-772-562-3909),

and to FWC at ImperiledSpecies@myFWC.com

- f. Post, facing the water, temporary signs concerning manatees prior to and during all in-water project activities. One sign which reads "Caution: Boaters" must be posted. A second sign measuring at least 8 1/2" by 11" explaining the requirements for "Idle Speed/No Wake" and the shutdown of in-water operations must be posted in a location prominently visible to all personnel engaged in water-related activities. Use temporary signs that have already been approved for this use by the Florida Fish and Wildlife Conservation Commission (FWC) must be used (see MyFWC.com/manatee). Questions concerning these signs can be sent to the email address listed above. Remove all signs upon completion of the Project.
- g. Comply with all manatee protection requirements of regulatory permits applicable to this Project.

#### K. Forest Protection

- 1. Compliance with State and Federal Regulations: In carrying out work within or adjacent to State or National forests or parks, comply with all of the regulations of the State or Federal authority having jurisdiction, governing the protection of and the carrying out of work in forests or parks, and observe all sanitary laws and regulations with respect to the performance of work in these areas. Keep the areas in an orderly condition, dispose of all refuse, and obtain permits for the construction, installation, and maintenance of any construction camps, living quarters, stores, warehouses, sanitary facilities, and other structures; all in accordance with the requirements of the forest or park official.
- 2. Prevention and Suppression of Forest Fires: Take all reasonable precautions to prevent and suppress forest fires. Require employees and subcontractors, both independently and at the request of forest officials, to do all reasonably within their power to prevent and suppress forest fires. Assist in preventing and suppressing forest fires, and make every possible effort to notify a forest official at the earliest possible moment of the location and extent of all fires. Extinguish the fire if practicable.

#### L. Preservation of Property

- 1. General:
  - a. Protect all geodetic monuments, horizontal or vertical, located within the limits of construction.
  - b. All street name signs shall remain in place during time of construction except those required to be relocated due to interference with actual construction. All signs relocated or damaged by Contractor during the course of the work shall be re-installed or replaced at

the proper location, as soon as possible at Contractor's expense.

- c. Prior to the removal of any traffic control signs that interfere with the construction, Contractor shall provide temporary signing or other provisions to assure a continuous flow of traffic under at least the same conditions as previously existed.
- d. All signs that are found to be unserviceable shall be reported to the Miami-Dade County, Department of Transportation and Public Works, Traffic Signals & Signs Division, at (305) 592-3580, prior to the commencement of work.

#### 2. Contractor's Use of Streets and Roads:

- a. When hauling materials or equipment to the project over roads and bridges on the State road system, County road system, or city street system, and such use causes damage, immediately, at no expense to the County, repair such road or bridge to as good a condition as before the hauling began.
- b. The Department may modify the above requirement in accordance with any agreement Contractor might make with the governmental unit having jurisdiction over a particular road or bridge, provided that Contractor submits written evidence of such agreement to Engineer prior to commencement of the Work.
- c. The use of public streets and alleys shall be such as to provide a minimum of inconvenience to the public and to other traffic. Contractor shall so conduct his operations that he shall not close any thoroughfare nor interfere in any way with traffic on railway, highways, or on water, without the written consent of the proper authorities.
- d. Contractor must immediately remove any earth or other excavated material spilled from trucks and clean the streets to the satisfaction of the governing authority.
- e. The Department has not made any attempt to define the equipment to be used in transporting the excavated material since this may vary, however, Contractor shall abide by the following general requirements:
  - 1) Transport vehicles must be of the type(s) approved for this application by the political jurisdiction involved.
  - 2) General requirements are that the vehicles have watertight bodies that they are properly equipped and fitted with seals and covers to prohibit material spillage or draining, and that they are cleaned as often as is necessary to prevent deposit of material on roadways.
  - 3) Vehicles must be loaded within all legal weight limits and operated safely within all traffic and speed regulations.

- f. The Department will not allow the operation of equipment or hauling units of such weight as to cause damage to previously constructed elements of the project, including but not necessarily limited to bridges, drainage structures, base course, and pavement.
  - g. Do not operate hauling units or equipment loaded in excess of the maximum weights specified for Overloaded Equipment on existing pavements that are to remain in place (including pavement being resurfaced), cement-treated subgrades and bases, concrete pavement, any course of asphalt pavement, and bridges.
  - h. Engineer may allow exceptions to these weight restrictions for movement of necessary equipment to and from its worksite, for hauling of offsite fabricated components to be incorporated into the Project, and for crossings as specified in the Contract Documents.
3. Protection of Existing Utility Poles:
- a. Ensure that existing utility poles are properly protected during installation of pipes and structures and must coordinate with the utility pole owner any safeguards necessary to protect the utility pole, including bracing of the pole, if necessary. All costs for protection of utility poles and any costs for the temporary bracing by the utility pole owner shall be the responsibility of Contractor and shall be considered incidental to and included in the Contract prices.
4. Traffic Signs, Signal Equipment, Highway Lighting and Guardrail:
- a. Protect all existing roadside signs, signal equipment, highway lighting and guardrail, for which permanent removal is not indicated, against damage or displacement. Whenever such signs, signal equipment, highway lighting or guardrail lie within the limits of construction, or wherever so directed by Engineer due to urgency of construction operations, take up and properly store the existing roadside signs, signal equipment, highway lighting and guardrail and subsequently reset them at their original locations or, in the case of widened pavement or roadbed, at locations designated by Engineer.
  - b. If the Department determines that damage to such existing or permanent installations of traffic signs, signal equipment, highway lighting or guardrail is caused by a third party, and is not otherwise due to any fault or activities of Contractor, the Department will, with the exception of any damage resulting from vandalism, compensate Contractor for the costs associated with the repairs. Repair damage caused by vandalism at no expense to the County.
5. Operations Within Railroad Right-of-Way:
- a. Notification to the Railroad Company: Notify the superintendent of the railroad company, as shown on the Plans, and Engineer at least 72 hours before beginning any operation within the limits of the railroad right-of-way; any operation requiring movement of employees, trucks, or other equipment across the tracks of the railroad company at other than an established public crossing; and any other work that may affect railroad operations or property.
  - b. Contractor's Responsibilities: Comply with whatever requirements an authorized representative of the railroad company deems necessary in order to safeguard the railroad's property and operations. Contractor is responsible for all damages, delays, or injuries and all suits, actions, or claims brought on account of damages or injuries resulting from Contractor's operations within or adjacent to railroad company right-of-way.
  - c. Watchman or Flagging Services: The railroad company will furnish protective services (i.e., watchman or flagging services) to ensure the safety of railroad operations during certain periods of the project. The Department will reimburse the railroad company for the cost thereof. Schedule work that affects railroad operations so as to minimize the need for protective services by the railroad company.
6. Utilities:
- a. General:
    - 1) Contact the Sunshine State One Call of Florida, Inc. at 1-800-432-4770 and other affected utility owners at least 48 hours prior to commencing any trenching or excavation work on this Project.
    - 2) Make all necessary arrangements with the utility companies concerned for maintenance of their lines during the construction period. In the event that a relocation of utilities is required, but has not been accomplished prior to the effective date of the "Notice to Proceed," Contractor nevertheless must commence work under this Contract, and must schedule his work to avoid interference with the utility relocation work.
    - 3) County will not be liable for any delay or added expense the Contractor experiences due to the activities of utility companies, nor shall the County be held responsible for any damages to any utilities due to any actions by Contractor.
  - b. Arrangements for Protection or Adjustment:
    - 1) Do not commence work at points where the construction operations are adjacent to utility facilities or other property, until making arrangements with the utility facilities to

protect against damage that might result in expense, loss, disruption of service, or other undue inconvenience to the public or to the owners. Contractor is solely and directly responsible to the owners and operators of such properties for all damages, injuries, expenses, losses, inconveniences, or delays caused by Contractor's operations.

- 2) The Department will make the necessary arrangements with utility owners for removal or adjustment of utilities where Engineer determines that such removal or adjustment is essential to the performance of the required construction. The Department will not consider relocation or adjustment requests based on Contractor's proposed use of a particular method of construction or a particular type of equipment as essential to the construction of the Project if Contractor could use other common methods and equipment without relocating or adjusting the utility. Engineer will determine the responsibility for any such required adjustments of utilities. Contractor shall make all requested relocations or adjustments because of delivery to the job site of Contractor-furnished materials, at no expense to the County.
- 3) The Department considers relocations and adjustments (or other protection) under the following circumstances as essential to the construction of the Project:
  - a) Utilities lying within the vertical and horizontal construction limits, plus the reasonably required working room necessary for operation of equipment normally used for the particular type of construction, all as determined by Engineer (and except as provided in paragraph (d) below). (In the case of overhead electrical conductors that carry more than 400 Volts, a minimum of 10 feet clearance between the conductor and the nearest possible approach of any part of the equipment is required, except where the utility owner effects safeguards approved by OSHA.)
  - b) Utilities lying within the horizontal limits of the project and within 12 inches below the ground surface or the excavation surface on which Contractor operates construction equipment, or within 12 inches below the bottom of any stabilizing course specified in the Plans.
  - c) Utilities lying within the normal limits of excavation for underground drainage facilities or other structures (except as provided in paragraph (d) below). Such normal limits shall extend to side slopes along the angle of repose, as established by sound engineering practice, unless the Contract Documents require support of the excavation sides

by sheeting or Contractor elects to sheet such excavation for his own convenience.

- d) Where utilities cross pipe trenches transversely within the excavation area, but not within positions from which relocation or removal is necessary, the utility owner is responsible for providing and effecting all reasonable measures for their support and protection during construction operations. Cooperate with the utility owner in the owner's effecting of such support and protective measures. Contractor is responsible for all damage to the utility that is caused by Contractor's neglect or failure to cooperate or to use proper precaution in performing his work.
- 4) In the event that a temporary relocation of a utility or a particular sequence of timing in the relocation of a utility is necessary, Engineer will direct such relocation so as to cause the least impediment to the overall construction operations. The Department is not responsible for utility adjustments or temporary relocation work, or for the conditions resulting there from, where such adjustments are:
    - a) Not necessitated by the construction of the Project,
    - b) Done solely for the benefit or convenience of the utility owner or its contractor, or Contractor where the Department considers his construction procedures to be other than normal, or
    - c) Not shown on the approved plans for the utility relocation or the construction of the Project.
  - c. Cooperation with Utility Owners:
    - 1) Cooperate with the owners of all underground or overhead utility lines in their removal and rearrangement operations in order that these operations may progress in a reasonable manner, that duplication or rearrangement work may be reduced to a minimum, and that services rendered by the utility owners will not be unnecessarily interrupted.
    - 2) In the event of interruption of water or other utility services as a result of accidental breakage, exposure, or lack of support, promptly notify the proper authority and cooperate with the authority in the prompt restoration of service. If water service is interrupted and Contractor is performing the repair work, Contractor shall work continuously until the service is restored. Do not begin work around fire hydrants until the local fire authority has approved provisions for continued service.
  - d. Utility Adjustments:

- 1) Certain utility adjustments and reconstruction work may be underway during the progress of the Contract. If known prior to award, the Department will include in the Contract documents the utility authorities who are scheduled to perform utility work on the Project.
  - 2) Cooperate with the various utility construction crews who are maintaining utility service.
  - 3) Exercise due caution when working adjacent to relocated utilities. Repair all damage to the relocated utilities resulting from his operations at no expense to the County.
  - 4) Protect utility facilities in accordance with the requirements of the Contract Documents and the owner.
- e. Weekly Meetings:
- 1) Conduct weekly meetings on the job site with all the affected utility companies and Engineer in attendance to coordinate project construction and utility relocation. Submit a list of all attendees one week in advance to Engineer for approval.
  - 2) Provide the approved Work Progress Schedule and Work Plan for the Project, as specified in the Contract Documents, to document the schedule and plan for road construction and utility adjustments.
  - 3) When utility relocations no longer affect construction activities, Contractor may discontinue the meetings with Engineer's approval.

M. Responsibility for Damages, Claims, etc.

1. Contractor to Provide Indemnification:
  - a. Contractor shall indemnify and hold harmless the County, its officers and employees from liabilities, damages, losses and costs, including, but not limited to, reasonable attorney's fees, to the extent caused by the negligence, recklessness, or intentional wrongful misconduct of Contractor and persons employed or utilized by Contractor in the performance of the construction Contract.
  - b. It is specifically agreed between the parties executing this Contract that it is not intended by any of the provisions of any part of the Contract to create in the public or any member thereof, a third party beneficiary hereunder, or to authorize anyone not a party to this Contract to maintain a suit for personal injuries or property damage pursuant to the terms or provisions of this Contract.
2. Guaranty of Payment for Claims: Contractor guaranties the payment of all just claims for materials, supplies, tools, or labor and other just claims against him or any subcontractor, in connection with the Contract. The Department's final acceptance and

payment does not release Contractor's bond until all such claims are paid or released.

N. Contractor's Responsibility for Work

1. Until the Department's acceptance of the work, take charge and custody of the work, and take every necessary precaution against injury or damage to the work by the action of the elements or from any other cause whatsoever, arising either from the execution or from the nonexecution of the work. Rebuild, repair, restore, and make good, without additional expense to the Department, all injury or damage to any portion of the work occasioned by any of the above causes before its completion and acceptance, except that in case of extensive or catastrophic damage, the Department may, at its discretion, reimburse Contractor for the repair of such damage due to unforeseeable causes beyond the control of and without the fault or negligence of Contractor, including but not restricted to Acts of God, of the public enemy, or of governmental authorities.

O. Opening Sections of Roadway to Traffic

1. Whenever any bridge or section of roadway is in an acceptable condition for travel, Engineer may direct Contractor to open it to traffic. The Department's direction to open a bridge or roadway does not constitute an acceptance of the bridge or roadway, or any part thereof, or waive any Contract provisions. Perform all necessary repairs or renewals, on any section of the roadway or bridge thus opened to traffic under instructions from Engineer, due to defective material or work or to any cause other than ordinary wear and tear, pending completion and Engineer's acceptance of the roadway or bridge, or other work, at no expense to the County.

P. Scales for Weighing Materials

1. Applicable Regulations: When determining the weight of material for payment, use scales meeting the requirements of Chapter 531, F.S., pertaining to specifications, tolerances, and regulations, as administered by the Bureau of Weights and Measures of the Florida Department of Agriculture.
2. Base for Scales: Place such scales on a substantial horizontal base to provide adequate support and rigidity and to maintain the level of the scales.
3. Protection and Maintenance: Maintain all scale parts in proper condition as to level and vertical alignment, and fully protect them against contamination by dust, dirt, and other matter that might affect their operation.

Q. Source of Forest Products

1. As required by Section 255.20, F.S., where price and quality are equal, and when available, use only timber, timber piling, or other forest products that are produced and manufactured in the State of Florida. This provision does not apply to Federal-aid projects.

R. Dust Control

1. Dust control measures are required as necessary to prevent the surface and air transport of dust from any construction activity performed under this contract. This may include but is not limited to: Pre-watering deeply before excavation; scheduling thorough and consistent watering that does not run off the site; applying best management practices in the loading, offloading, and transport of soils and miscellaneous materials; covering or otherwise stabilizing piles when necessary; and planning schedules so control measures are available throughout the project.
2. Ensure that excessive dust is not transported beyond the limits of construction in populated areas. Contractor may control dust for embankments or other cleared or unsurfaced areas by applying water, as directed by Engineer. When included in the Plans, install mulch, seed, sod, or temporary paving as early as practical. Control dust during the storage and handling of dusty materials by wetting, covering, or other means as approved by Engineer.
3. When cutting through concrete, care should be exercised to prevent dust from becoming air borne. Contractor must use an engineering control such as the use of a wet saw or dust collector. Engineer shall have the final determination when in a particular circumstance this is not feasible, and the concrete must be cut dry.
4. No separate item for dust control measures is included for payment in this Contract. Contractor must consider the cost of any dust control measures that is necessary for the proper construction of the Project as included in the Contract price for items of work for which dust control measures are required.

S. Dredging and Filling

1. Section 370.033, F.S., requires that all persons, who engage in certain dredge or fill activities in the State of Florida, obtain a certificate of registration from the Florida Department of Environmental Protection, Tallahassee, Florida 32301, and that they keep accurate logs and records of all such activities for the protection and conservation of the natural resources. Obtain details as to the application of this law from the Department of Environmental Protection and contact local regulatory agencies for additional applicable requirements.

T. Contractor's Motor Vehicle Registration

1. Provide the Department with proof that all motor vehicles operated or caused to be operated by such Contractor are registered in compliance with Chapter 320, F.S. Submit such proof of registration in the form of a notarized affidavit to the Department.
2. The Department will not make payment to Contractor until the required proof of registration is on file with the Department.

U. Compliance with FHWA 1273:

1. For federally funded projects and when required by law, comply with the provisions contained in FHWA-1273.
2. The FHWA-1273 Electronic version, dated May 1, 2012 is posted on the FDOT's website at the following URL address:  
[https://fdotwww.blob.core.windows.net/sitefinity/docs/default-source/programmanagement/implemented/urlinspecs/files/fhwa1273.pdf?sfvrsn=1cd7961f\\_12](https://fdotwww.blob.core.windows.net/sitefinity/docs/default-source/programmanagement/implemented/urlinspecs/files/fhwa1273.pdf?sfvrsn=1cd7961f_12)
3. Take responsibility to obtain this information and comply with all requirements posted on this website up through five calendar days before the opening of bids.
4. If the FDOT website cannot be accessed, contact FDOT Department's Specifications Office Web Coordinator at (850) 414-4101.

a. s

1.06 PROSECUTION AND PROGRESS

A. Subletting Or Assigning The Contract

1. Do not, sell, transfer, assign or otherwise dispose of the Contract or Contracts or any portion thereof, or of the right, title, or interest therein, without written consent of the Department. If the Contractor chooses to sublet any portion of the Contract, the Contractor must provide a written request to sublet work on the Certification of Sublet Work form developed by the Department for this purpose.
2. Contractor must perform, with its own organization, contract work amounting to not less than 30 percent (or a greater percentage if specified elsewhere in the Contract Documents) of the total original contract price, excluding any specialty items designated by the County. Specialty items may be performed by subcontract and the amount of any such specialty items performed may be deducted from the total original contract price before computing the amount of work required to be performed by the contractor's own organization.
  - a. "Its own organization" is construed to include only workers employed and paid directly by the prime contractor and equipment owned or rented by the prime contractor, with or without operators. Such term does not include employees or equipment of a subcontractor, assignee, or agent of the prime contractor.
  - b. "Specialty Items" is construed to be limited to work that requires highly specialized knowledge, abilities, or equipment not ordinarily available in the type of contracting organizations qualified and expected to bid on the contract as a whole and in general are to be limited to minor components of the overall contract.
3. The contract amount, upon which the requirements set forth in this Subarticle is computed, includes the cost of material and manufactured products which are to be purchased or produced by the Contractor under the

provisions of the Contract. For the purpose of meeting this requirement the Department will not consider off-site commercial production of materials and manufactured component products that the Contractor purchases, or their transportation to the project, as subcontracted work.

4. If the Contractor sublets a part of a Contract item, the Department will use only the sublet proportional cost in determining the percentage of subcontracted normal work.
5. Execute all agreements to sublet work in writing and include all pertinent provisions and requirements of the Contract. All other agreements must be in writing and reference all applicable Contract provisions. Upon request, furnish the Department with a copy of the subcontract and agreement. The subletting of work does not relieve the Contractor or the surety of their respective liabilities under the Contract.
6. The Department recognizes a subcontractor only in the capacity of an employee or agent of the Contractor, and the Engineer may require the Contractor to remove the subcontractor as in the case of an employee.
7. Contractor must furnish:
  - a. A competent superintendent or supervisor who is employed by its firm, has full authority to direct performance of the Work in accordance with the Contract requirements, and is in charge of all construction operations (regardless of who performs the work); and
  - b. Such other of its own organizational resources (supervision, management, and engineering services) as the Engineer determines is necessary to assure the performance of the Contract.

#### B. Notice to Proceed

1. Unless otherwise agreed to by the parties, the Department may issue the Notice to Proceed (NTP) within 30 Days after all conditions for Contract execution have been met. The NTP will identify the date Contractor is to begin the construction and will start the Contract Time.

#### C. Project Signs

1. Project Signs will be provided by Miami-Dade County Internal Services Department (ISD) at no cost to Contractor.
2. The type, location, and number of signs required per each work site shall be at the discretion of Engineer.
3. No work shall commence until the Project Signs are secured in place as directed by Engineer.
4. Maintain and Relocate Project Signs.
  - a. Maintain and relocate Project Signs throughout the duration of the Contract, as directed by Engineer and at no additional cost to Miami-Dade County.

- b. Install relocated Project Signs as required by Engineer. All materials and work necessary to secure, brace, mount, place, and maintain the Project Signs will be provided at Contractor's expense.
- c. Notify Engineer immediately if at any time, during the Contract duration, a Project Sign becomes damaged, defaced, or unreadable. If Engineer determines that a replacement sign is required, Engineer will request it from ISD.

5. Upon completion of the Contract or at any time as directed by Engineer, deliver all available Project Signs to the designated ISD facility.

6. No separate payment will be made for the activities described above.

#### D. Schedule Of Values

1. A Schedule of Values is required for any Stipulated (Lump) sum contract, or for major lump sum items on Unit price contracts for which Contractor requests progress payments.
2. Upon notification of intent to Award and prior to the Notice to Proceed, submit to Engineer for review and approval, a preliminary Schedule of Values that:
  - a. Logically subdivides the Work into component parts with sufficient detail to serve as the basis for progress payments during performance of the Work and correlates to the Work Progress Schedule.
  - b. Includes quantities and prices of items for all of the Work which when added together equal either the Contract Base Award Amount for a Stipulated sum contract or the Contract Price for a major lump sum item in a Unit price contract.
  - c. Separately identifies the scope of work to be performed by any SBE-CONST utilized to satisfy any SBE-CONST goal in the Contract. In addition, payment requisitions for the scope of work of such SBE-CONST shall be accompanied by the statements of completion of the work of the SBE-CONST and shall be accompanied by appropriate documentation including invoicing and checks reflecting payment of the SBE-CONST for the previous construction draw.

3. The Schedule of Values for a Stipulated sum contract will be acceptable to Engineer as to form and substance if it provides a reasonable allocation of the Contract Base Award Amount to component parts of the Work.

4. When directed by Engineer, submit at least 10 days prior to the next application for progress payment, a revised or updated Schedule of Values to address any changes in the Work.

#### E. Preconstruction Conference

1. A Preconstruction Conference will be held with Contractor, members of the Department and other Miami-Dade County Agencies, representative of Utility Companies, and other municipalities or contractors affected by the Work. The Department will set the time and place of this conference.
2. Submit the following items to Engineer at the Preconstruction Conference unless otherwise noted:
  - a. Two copies of the proposed Work Progress Schedule. (Provide an updated schedule within 5 days of each Work Order for work order contracts.)
  - b. Contractor's Chain of Authority.
  - c. Contractor's Emergency Telephone Numbers, during work hours, after hours, and on weekend, of Prime and MOT Contractor's Representatives.
  - d. Letter naming Contractor's Superintendent and his qualifications.
  - e. Letter naming Contractor's Work Site Traffic Supervisor and a copy of their respective Certification(s).
  - f. Letter naming Contractor's MOT Flagmen and a copy of their training Certification(s).
  - g. Maintenance of Traffic Plan: Letter outlining the Specific Maintenance of Traffic Plan or Plans that will be used during construction. If the MOT plan is noted in the Construction Plans, it will be for reference only. Contractor is responsible to provide his own MOT Plan. MOT plans must be submitted within 5 days of the date of each Work Order for work order contracts.
  - h. Shop drawing submittal schedule. To be submitted within 5 days of the date of each Work Order for work contracts.
  - i. List of potential subcontractors and rental agreements.
  - j. Letter listing the material providers for this project, with the respective name and address; and letter certifying the compliance of the material with the project requirements.
  - k. List of equipment to be utilized for construction; including make, model, year, name and description of equipment.
  - l. Contractor's Erosion Control Plan (ECP) pursuant to the requirements of the Contract Documents.
  - m. Lighting plan if Contractor intends to perform any night work.
  - n. All other submittal requirements stipulated in the Contract Documents.

F. Scheduling of the Work

1. Work Progress Schedule.

- a. Within 21 days after Contract award or at the Preconstruction Conference, whichever is earlier, submit to Engineer for approval two copies of a Work Progress Schedule for this

Project. Engineer will review and respond to Contractor within 15 days of receipt.

- b. The Work progress Schedule must show the various activities of work in sufficient detail to demonstrate a reasonable and workable plan to initiate, construct, and complete all requirements of the Contract Documents within the Contract Duration and must:
  - 1) Include a projected Project completion, measured in dollars and time, on a monthly basis or at each progress payment cutoff date.
  - 2) Identify a date for substantial completion with "sufficient time" between substantial completion and end of Contract Duration for final inspections, final roadway striping if required, development of a punch list by the Engineer, completion of all punch list items by Contractor, final submittals, and any remaining site restoration activities. "Sufficient time," as it pertains solely to this requirement, means no less than 60 days unless otherwise required by the Contract Documents or approved in writing by Engineer.
  - 3) Include the order and interdependence of activities and the sequence for accomplishing the Work including phased restoration of areas impacted by work.
  - 4) Describe activities in sufficient detail so that the Engineer can readily identify the Work and measure the progress of each activity.
  - 5) Show each activity with a beginning work date, activity duration, and a monetary value.
  - 6) Include within the activities the necessary steps for procurement, fabrication, and delivery of materials, plant, and equipment.
  - 7) Include the review time for shop drawings and submittals.
  - 8) Include the Critical Path and milestone activities when milestones are required by the Contract Documents.
  - 9) In projects with more than one phase, adequately identify each phase and its substantial completion date, and do not allow phase specific activities to span more than one phase.
- c. Submit with the Work Progress Schedule a narrative report describing current project schedule status and identifying potential delays. This report will include a description of the progress made since the previous schedule submission and objectives for the upcoming 30 calendar days. It will be submitted on 8.5 by 11 inch paper. This report shall at a minimum include the following information:
  - 1) Indicate if the Project is on schedule, ahead of schedule or behind schedule. If the Project



is ahead of schedule or behind schedule, the report shall include the specific number of calendar days. If the Project is behind schedule, the report shall include a detailed recovery plan that will put the Project back on schedule.

- 2) The report will describe the current critical path of the Project and indicate if this has changed in the last 30 calendar days. Discuss current successes or problems that have affected either the critical path's length or have caused a shift in the critical path within the last 30 calendar days. Identify specific activities, progress, or events that may reasonably be anticipated to impact the critical path within the next 30 calendar days, either to affect its length or to shift it to an alternate path.
- 3) List all schedule logic or duration changes that have been made to the schedule since the previous submission. For each change, describe the basis for the change and specifically identify the affected activities by identification number.
- 4) Identify any and all activities, either in progress or scheduled to occur within the following 30 days that require County participation, review, approval, etc.
- d. Submit, with the Work Progress Schedule, clear documentation demonstrating that all necessary coordination activities with utility owners that have facilities within the limits of construction have been conducted. In addition, incorporate into the work progress schedule any utility adjustment schedules included in the Contract Documents unless the utility company and the Department mutually agree to changes to the utility schedules shown in the Contract.
- e. Engineer will return inadequate schedules to Contractor for corrections. Resubmit a corrected schedule within 15 days from the date of Engineer's return transmittal.
- f. Submit an updated Work Progress Schedule, for Engineer's acceptance, if there is a significant change in the planned order or duration of an activity. Engineer will review the corrected schedule and respond within 7 days of receipt.
- g. By acceptance of the schedule, Engineer does not endorse or otherwise certify the validity or accuracy of the activity durations or sequencing of activities. Engineer will use the accepted schedule as a baseline against which to measure the progress.
- h. If Contractor fails to finalize either the initial or a revised schedule in the time specified, Engineer will withhold all Contract payments until Engineer accepts the schedule.

## 2. Weekly Work Progress Meetings:

- a. Coordinate weekly meetings to discuss Contract progress with Engineer including near term scheduled activities, utility relocations, and problems and their proposed solutions.
- b. Submit a Two-Week "Look Ahead" Planning Schedule at each weekly meeting, showing the items of work planned for the next two weeks. Develop the schedule in Bar Chart format, identifying current and planned activities and related Contract Schedule work activities, including subcontractor work. Designate all activities that are controlling work items as determined by the currently accepted Contract Schedule.
- c. A report shall be submitted at each weekly meeting identifying schedule activity progress including actual start or finish dates achieved for any activities.

## 3. Prosecution of the Work.

- a. Give the Work the constant attention necessary to ensure the scheduled progress, and cooperate fully with Engineer and with other contractors at work in the vicinity.
- b. Do not commence work under the Contract until after the Department has issued the Notice to Proceed. Thereafter, commence the Work and continue all work in an expeditious manner to a conclusion acceptable to Engineer and in accordance with the approved Work Progress Schedule.
- c. All requirements of the Contract, including completion of punch list items and final deliverables, must be completed during the Contract Duration.
- d. Compliance with Time Requirements: Commence work in accordance with the approved Work Progress Schedule and provide sufficient labor, materials and equipment to complete all work as scheduled. Should Contractor fail to furnish sufficient and suitable equipment, forces, and materials, as necessary to prosecute the Work in accordance with the required schedule, Engineer may withhold all progress payments that are, or may become due, or suspend the work until Contractor corrects such deficiencies.
- e. Provisions for Convenience of Public: Schedule construction operations so as to minimize any inconvenience to adjacent businesses or residences. Where necessary, Engineer may require Contractor to first construct the work in any areas along the Project where inconveniences caused by construction operations would present a more serious handicap. In such critical locations, where there is no assurance of continuous effective prosecution of the work once the construction operations are begun, Engineer may require Contractor to delay removal of the existing (usable) facilities.

- f. The lack of equipment or unsuitability of said equipment shall not be an acceptable reason for falling behind schedule.
  - g. If Contractor fails to complete all work under the Contract, within the time specified in the "Notice to Proceed" and/or Work Order(s), or fails to perform the Work with sufficient personnel and equipment or with sufficient materials to assure the prompt completion of the work assigned, or discontinues the prosecution of the Work, or fails to resume work which has been discontinued within a reasonable time after notice to do so, or becomes insolvent or is declared bankrupt, or files for reorganization under the bankruptcy or insolvency code, or for any other cause whatsoever, fails to carry on the work in an acceptable manner, or if the surety executing the bond, becomes unsatisfactory in the opinion of the County, Engineer will give notice in writing to Contractor and his surety of such delay, neglect, or default. Additionally, the County may opt to not issue further Work orders and/or to terminate the Contract in addition to assigning a non-responsive Contractor Evaluation rating. Continuous failure by Contractor to complete work in a timely fashion may result in the County not issuing further work and/or cancellation of the Contract.
4. Additional Requirements for Work Order Contracts:
- a. The completion time for each Work Order will consist of a reasonable duration determined by Engineer.
  - b. After the "Notice to Proceed" and issuance of the Work Order(s), Contractor shall commence the Work on the effective date of each Work Order and continue all work in an expeditious manner to a conclusion acceptable to Engineer.
  - c. All activities required to be performed for each Work Order, including completion of punch list items and final deliverables, must be completed during the Work Order Days provided for each Work Order.
  - d. Unless otherwise provided by the Contract Documents, Engineer may issue subsequent Work Order(s) any time after Engineer determines that work under an existing Work Order is substantially completed, even if site restoration or punch list items are pending for the existing Work Order.
- G. Progress of the Work.
1. Unless otherwise stipulated herein, progress of the Work will be evaluated monthly and compared to the approved Work Progress Schedule.
    - a. When dollars invoiced by Contractor on the Project are 15 percent greater than the estimated dollars for the work scheduled, Engineer may request in writing, that Contractor submit a revised Work Progress Schedule for approval by the next scheduled monthly submittal date.
  2. The notice of unsatisfactory performance will also allow a reasonable period of time, as determined by Engineer but not to exceed 30 Days from receipt of the notice, for Contractor to bring the progress of the Work into compliance with the current accepted work progress schedule or to provide acceptable written justification for the delay. Contractor must do the following things within the time specified in the notice to Contractor of unsatisfactory performance:
    - a. Submit a revised baseline progress schedule and recovery plan to Engineer for review and approval. Demonstrate the proposed method to complete the Project within the remaining time specified in the current accepted work progress schedule; and
    - b. If Contractor is unable to provide such a revised schedule, a late completion schedule shall be submitted indicating the time required to complete the Work. The Department's approval of the late completion schedule will not operate as a waiver of the Department's right to assess liquidated damages;
    - c. Take all necessary action, subject to Engineer's approval, to ensure completion of the Project at no additional cost to the Department within the remaining time specified in the accepted schedule. Actions
- b. When the dollars earned by Contractor on the Project are 15 percent less than the estimated dollars for the work scheduled, Engineer may deem the progress of the Work unsatisfactory and will issue a notice to Contractor of unsatisfactory performance.
  - c. In the event a noncritical item becomes critical as determined by Engineer, Contractor must submit a revised CPM schedule.
  - d. When an activity on the critical path, as shown on the current approved Work Progress Schedule, has exceeded its late start date by 7 Days, Engineer will deem the progress of Work unsatisfactory and will hold a meeting with Contractor to address the schedule within 7 Days of the discovery. If a resolution cannot be determined within 5 Days, Engineer will issue a notice to Contractor of unsatisfactory performance.
  - e. When it becomes apparent that an activity on the critical path, as shown on the current approved Work Progress Schedule, has exceeded its original duration by 10 or more Days, regardless of the Contract's definition of Contract Time, Contractor must submit a revised Work Progress Schedule for approval within 5 Days of the discovery and Engineer will issue a notice of unsatisfactory performance to the Contractor and identify the unsatisfactory performance.

may include but not be limited to the following:

- 1) Additional overtime;
- 2) Added work shift;
- 3) Additional workforce;
- 4) Extended workweek;
- 5) Additional Equipment; or
- 6) A combination of these.

#### H. Performance of Work

1. Give due and adequate notices to those in control of all properties that may be affected by the construction activities.
2. Keep on the job site sufficient plant and equipment to meet the requirements of the Work. The plant shall be kept in a satisfactory operating condition and be capable of safely and efficiently performing the Work as set forth in the Plans and Specifications. The equipment and all operations shall be subject to inspection by Engineer at all times.
3. Submit for approval by Engineer, a description of the type of materials and equipment to be used; and the method of procedure to be used in the performance of the Work.

#### 4. Condition of Equipment

- a. All equipment used in the performance of the Work must be in first class operating condition, including proper mufflers and other silencing accessories. All equipment must be properly lubricated on a special maintenance type schedule to reduce noise, including tracks, rollers, idlers, sheaves and other noise producing components. Care must be taken to prevent oil spillage of any kind or oil dripping from equipment. All dewatering pumps and welding machines must be engine driven or powered by Contractor furnished generators. The temporary power source available at the jobsite is not sufficient to power that type of equipment.
- b. If the equipment used proves less than satisfactory and is unduly or needlessly disturbing the neighbors, in the opinion of Engineer, he will have the right to order Contractor to immediately modify the equipment to make it satisfactory, or to change to other equipment that is satisfactory at no additional cost to the County.

#### 5. Saw Cutting:

- a. When required in performance of this Contract, material may be removed by either saw cutting the slab perpendicular to the long edge, or by any other means that will produce a clean neat cut and that is acceptable to Engineer. All costs for saw cutting and/or any other necessary means for accomplishing the

bid items listed in this Contract shall be included in the cost for said item.

#### 6. Open Excavations:

- a. At the close of each workday, Contractor shall refill all open excavations, or cover open excavations with steel plates capable of supporting vehicular traffic at no additional cost to the County.

#### 7. Florida Trench Safety Act

- a. The Florida Trench Safety Act (Sections 553.60-553.64, Florida Statutes) is hereby incorporated by reference and made a part of these Specifications. The purpose and intention of the State of Florida "Trench Safety Act" is to provide for increased worker safety by requiring compliance with sufficient standards for trench safety and providing additional specific requirements when the excavation is in excess of 5 feet deep. By executing the Contract, Contractor certifies that he is fully aware of the Trench Safety Act, and will comply with applicable trench safety standards.
- b. In accordance with Sections 553.60-553.64, F.S., the bidder acknowledges those included in the various items of the proposal and in the total bid price are costs for complying.

#### I. As-Built Drawings

1. Five (5) sets of complete "As-Built" drawings signed and sealed by either a Florida Registered Surveyor and Mapper or a Florida Registered Professional Engineer, shall be accurately recorded by Contractor and submitted to Engineer prior to final acceptance of the Work. As Built drawing required for Federally Funded Projects must be signed and sealed only by a Florida Registered Professional Engineer.
2. The As-Built Drawings must contain detailed information pertaining to the locations, spans, depths, and elevations of all significant elements of construction performed pursuant to the Contract Documents in addition to all information necessary to comply with Project permits and regulatory requirement.
3. All locations, depths, and elevations shall be taken by a Florida Registered Surveyor and Mapper and be shown on the As-Built drawings.
4. No separate payment will be made for the As-Built drawings.

#### J. Liquidated Damages

1. Contractor, or in case of his default the surety, shall pay to the County, not as a penalty but as liquidated damages, the amount stipulated below should Contractor fail to complete all work specified within the time stipulated in the Contract for substantial completion, including extra time granted in writing by the County. Substantial completion must be achieved

60 days prior to contract final acceptance, unless a different time is stipulated under contract duration on the Special Provisions. For Work Order based Contracts, liquidated damages shall be the amount stipulated below, computed for each Work Order, should Contractor fail to complete all work specified within the time stipulated in the Work Order, including extra time granted in writing by the County.

2. Applicable liquidated damages for each day after the scheduled substantial completion date are the amounts established in the following schedule:

Total Contract/Work Order Amount	Daily Charge Per Calendar Day
\$299,999 and under	\$980
\$300,000 but less than \$2,000,000	\$1,699
\$2,000,000 but less than \$5,000,000	\$2,650
\$5,000,000 but less than \$10,000,000	\$3,819
\$10,000,000 but less than \$20,000,000	\$4,687
\$20,000,000 but less than \$40,000,000	\$7,625
\$40,000,000 and over	\$10,467 plus 0.00005 of any amount over \$40 million (Round to nearest whole dollar)

3. Contractor, or in case of his default the surety, shall pay to the County, not as a penalty but as liquidated damages, 30% of the amount stipulated above under this Subarticle J.2 should Contractor fail to complete punch list items and deliver all required documents, including warranties, necessary to close out the project within the total time stipulated in the Contract for final acceptance, including extra time granted in writing by the County.
4. Engineer will count default days in calendar days.
5. County has the right to apply, as payment on such liquidated damages, any money the County owes Contractor.
6. County does not waive its right to liquidated damages due under the Contract by allowing Contractor to continue and to finish the work, or any part of it, after the expiration of the Contract/Work Order Time including granted time extensions.
7. The requirements of this Article may not be waived, compromised or settled without the express written consent of the Board of County Commissioners.

K. Limitations of Operations

1. General:

- a. Subject to any provision to the contrary provided in these Contract Documents, Work must not be carried out during the night or on Saturdays, Sundays or on County holidays without prior written approval from Engineer

issued at least 72 hours before these times so that proper inspection and engineering services may be scheduled.

- b. Prior written approval from Engineer, as specified in this Article, is not required for the performance of work that is necessary for proper care, maintenance, and protection of Work already done, or in cases when the Work would otherwise be endangered or when hazard to life or property would result, in which case Contractor must inform Engineer at the earliest possible opportunity of the same.
- c. All construction activities, designated by Engineer as requiring inspection by the County, must be scheduled to coincide with the hours of availability of Engineer or Engineer's duly authorized inspector. The hours of availability are from 7:00 AM until 4:30 PM Monday through Friday; unless otherwise approved by the Engineer, these construction activities must be scheduled to coincide with the aforementioned hours of availability.
- d. Work performed without the prior written approval of Engineer and without an Engineer's duly authorized inspector may be declared defective solely on the grounds that it was not properly inspected.
- e. In the event, that the Engineer approves work on night or on Saturdays, Sundays or on County holidays; the Contractor will be responsible to pay the overtime incurred during the approved overtime hours at the current inspector's hourly rate. Such payment will be deducted from the monthly invoice.
- f. Contractor must conform to all applicable laws, regulations, or ordinances with regard to labor employed, hours of work and general operations.

2. Night Work:

- a. Night work may be undertaken as a regular procedure when required by the Contract Documents or approved in writing by Engineer. Such approval, however, may be revoked at any time by Engineer if Contractor fails to maintain adequate equipment, lighting, and supervision for the proper prosecution and control of the Work at night pursuant to the requirements herein.
- b. For the purposes of this Article, the term "night" shall mean the period from 6:00 p.m. to 7:00 a.m. Due to traffic interference concerns, authorized night construction activities that may be disruptive to traffic flow can only be performed weekdays between 9:00 p.m. to 5:00 a.m.
- c. Prepare a specific work plan and submit it to the Engineer for approval at least one week in advance of the anticipated work. The plan must include a schedule of all activities of

work and show in detail the special arrangements that will be made to provide for all regulatory and Contract requirements including cordoning off the areas with sufficient roadway safety signs; providing approved MOT; worksite personnel and citizen safety; necessary lighting; and daily restoration of the work site.

- d. Obtain and comply with all necessary permits and authorizations from the applicable jurisdictions.
- e. Complete all scheduled work and restore the work site as required in the Engineer's approval.
- f. Lighting during nighttime operations:
  - 1) During active nighttime operations, furnish, place and maintain lighting sufficient to permit proper workmanship and inspection. Use lighting with 5 ft•cd minimum intensity. Arrange the lighting to prevent interference with traffic or produce undue glare to property owners. Operate such lighting only during active nighttime construction activities. Provide a light meter to demonstrate that the minimum light intensity is being maintained.
  - 2) Lighting may be accomplished by the use of portable floodlights, standard equipment lights, existing street lights, temporary street lights, or other lighting methods approved by Engineer.
  - 3) Submit a lighting plan at the Preconstruction Conference for review and acceptance by Engineer. Submit the plan on standard size plan sheets (not larger than 24 by 36 inch), and on a scale of either 100 or 50 feet to 1 inch. Do not start night work prior to the Engineer's acceptance of the lighting plan.
  - 4) During active nighttime operations, furnish, place and maintain variable message signs to alert approaching motorists of lighted construction zones ahead. Operate the variable message signs only during active construction activities.
  - 5) Where night work is required by the Contract Documents, include compensation for lighting for night work in the Contract prices for the various items of the Contract. Take ownership of all lighting equipment for night work.
3. Sequence of Operations: Do not open up work to the prejudice of work already started. Engineer may require Contractor to finish a section on which work is in progress before starting work on any additional section.
4. Interference with Traffic:
  - a. At all times conduct the Work in such manner and in such sequence as to ensure the least practicable interference with traffic. Operate all vehicles and other equipment safely and without hindrance to the traveling public. Park

all private vehicles outside the clear zone. Place materials authorized to be stored along the roadway so as to cause no obstruction to the traveling public as possible.

- b. Where existing pavement is to be widened and stabilizing is not required, prevent any open trench from remaining after working hours by scheduling operations to place the full thickness of widened base by the end of each day. Do not construct widening strips simultaneously on both sides of the road, except where separated by a distance of at least 1/4 mile along the road and where either the work of excavation has not been started or the base has been completed.
5. Coordination with other contractors:
    - a. Sequence the work and dispose of materials so as not to interfere with the operations of other contractors engaged upon adjacent work; join the work to that of others in a proper manner, in accordance with the spirit of the Contract Documents; and perform the work in the proper sequence in relation to that of other contractors; all as may be directed by Engineer.
    - b. Contractor is responsible for any damage done by him or his agents to the work performed by another contractor.
  6. Drainage: Conduct the operations and maintain the work in such condition to provide adequate drainage at all times. Unless otherwise required by the Contract Documents, do not obstruct existing functioning storm drains, gutters, ditches, and other run-off facilities.
  7. Fire Hydrants: Keep fire hydrants on or adjacent to the roadway accessible to fire apparatus at all times, and do not place any material or obstruction within 15 feet of any fire hydrant.
  8. Protection of Structures: Do not operate heavy equipment close enough to pipe headwalls or other structures to cause their displacement.
  9. Fencing: Erect permanent fence as a first order of business on all projects that include fencing where Engineer determines that the fencing is necessary to maintain the security of livestock on adjacent property, or for protection of pedestrians who are likely to gain access to the project from adjacent property.
  10. Contaminated Materials:
    - a. When the construction operations encounter or expose any abnormal condition that may indicate the presence of a contaminated material, discontinue such operations in the vicinity of the abnormal condition and notify Engineer immediately. Be alert for the presence of tanks or barrels; discolored earth, metal, wood, ground water, etc.; visible fumes; abnormal odors; excessively hot earth; smoke; or other conditions that appear abnormal as possible indicators of the presence of contaminated materials. Treat these conditions with extraordinary caution.

- b. Make every effort to minimize the spread of Contaminated Material into uncontaminated areas.
- c. Do not resume the construction operations until so directed by Engineer.
- d. Dispose of the Contaminated Material in accordance with the requirements and regulations of any Local, State, or Federal agency having jurisdiction. Where Contractor performs work necessary to dispose of Contaminated material, and the Contract does not include pay items for disposal, the Department will pay for this work as unforeseeable work.
- e. The Department may agree to hold harmless and indemnify Contractor for damages when Contractor discovers or encounters Contaminated materials or pollutants during the performance of services for the Department when the presence of such materials or pollutants were unknown or not reasonably discoverable. Such indemnification agreements are only effective if Contractor immediately stops work and notifies the Department of the Contaminated material or pollutant problem.
- f. Such indemnification agreement is not valid for damages resulting from Contractor's willful, wanton, or intentional conduct or the operations of Contaminated and Hazardous Material Contractors.

L. Qualifications of Contractor's Personnel

- 1. Meet the personnel qualifications requirements stipulated in Article 105 of the DTPW Specifications.
- 2. Provide competent, careful, and reliable superintendents, foremen, and workmen. Provide workmen with sufficient skill and experience to properly perform the work assigned to them. Provide workmen engaged on special work, or skilled work, such as bituminous courses or mixtures, concrete bases, pavements, or structures, or in any trade, with sufficient experience in such work to perform it properly and satisfactorily and to operate the equipment involved. Provide workmen that shall make due and proper effort to execute the work in the manner prescribed in the Contract Documents, or Engineer may take action as prescribed below.
- 3. It is prohibited as a conflict of interest for a Contractor to subcontract with a Consultant to perform Contractor Quality Control when the Consultant is under contract with the Department to perform work on any project described in Contractor's Contract with the Department. Prior to approving a Consultant for Contractor Quality Control, Contractor shall submit to the Department a Certificate from the proposed Consultant certifying that no conflict of interest exists.
- 4. Whenever Engineer determines that any person employed by Contractor is incompetent, unfaithful, intemperate, disorderly, or insubordinate, Engineer will provide written notice and Contractor shall discharge

the person from the work. Do not employ any discharged person on the Project without the written consent of Engineer. If Contractor fails to remove such person or persons, Engineer may withhold all payments that are or may become due, or suspend the work until Contractor complies with such orders. Protect, defend, indemnify, and hold the County, its agents, officials, and employees harmless from all claims, actions, or suite arising from such removal, discharge, or suspension of employees.

M. Temporary Suspension of Contractor's Operations

1. Authority to Suspend Contractor's Operations:

- a. Engineer has the authority to suspend Contractor's operations, wholly or in part. Engineer will order such suspension in writing, giving in detail the reasons for the suspension. Contract Time will be charged during all suspensions of Contractor's operations.
- b. Any work in the public right of way may be temporarily suspended by the roadway governing authority. If an extension of Contact time is authorized pursuant to the requirements of the Contract Documents, it will be of a non-compensable nature. All costs associated with temporary suspension including any demobilization or re-mobilization costs are the sole responsibility of the Contractor and no extra compensation will be allowed.
- c. No additional time extension will be granted to Contractor when the operations are suspended for the following reasons:
  - 1) Contractor fails to comply with the Contract Documents.
  - 2) Contractor fails to carry out orders given by Engineer.
  - 3) Contractor causes conditions considered unfavorable for continuing the Work.
- d. Immediately comply with any suspension order. Do not resume operations until authorized to do so by Engineer in writing. Any operations performed by Contractor, and otherwise constructed in conformance with the provisions of the Contract, after the issuance of the suspension order and prior to Engineer's authorization to resume operations will be at no cost to the County. Further, failure to immediately comply with any suspension order will also constitute an act of default by Contractor and is deemed sufficient basis in and of itself for the Department to declare Contractor in default, with the exception that Contractor will not have ten calendar days to correct the conditions for which the suspension was ordered.

2. Prolonged Suspensions: If Engineer suspends Contractor's operations for an indefinite period, store

all materials in such manner that they will not obstruct or impede the traveling public unnecessarily or become damaged in any way. Take every reasonable precaution to prevent damage to or deterioration of the work performed. Provide suitable drainage of the roadway by opening ditches, shoulder drains, etc., and provide any temporary structures necessary for public travel through the project.

3. Permission to Suspend Contractor's Operations: Do not suspend operations or remove equipment or materials necessary for completing the work without obtaining Engineer's written permission. Submit all requests for suspension of operations in writing to Engineer, and identify specific dates to begin and end the suspension. Contractor is not entitled to any additional compensation for suspension of operations during such periods.

4. Suspension of Contractor's Operations-Holidays:

a. Unless Contractor submits a written request to work on a holiday at least ten days in advance of the requested date and receives written approval from Engineer, Contractor must not work on the following days: Martin Luther King, Jr. Day; President's Day, Memorial Day; the Saturday and Sunday immediately preceding Memorial Day; Independence Day; Labor Day; the Saturday, and Sunday immediately preceding Labor Day; Columbus Day, Veterans' Day; Thanksgiving Day; the Friday, Saturday and Sunday immediately following Thanksgiving Day; and December 24 through January 2, inclusive. Contract Time will be charged during these holiday periods regardless of whether or not Contractor's operations have been suspended.

b. During such suspensions, remove all equipment and materials from the clear zone, except those required for the safety of the traveling public and retain sufficient personnel at the job site to properly meet all applicable requirements for: (1) Maintenance of Traffic; and (2) Prevention, Control, and Abatement of Erosion and Water Pollution. Contractor is not entitled to any additional compensation for removal of equipment from clear zones or for compliance with the aforementioned requirements during such holiday periods.

N. Computation of Contract Time

1. Date of Beginning of Contract Time: The Contract Time begins on the effective start date of the "Notice to Proceed." Perform the Work fully, entirely, and in accordance with the Contract Documents within the Contract Time(s) specified in the Contract Documents, or as may be extended in accordance with the provisions herein.

2. Contract Time Extensions:

a. The Department will consider the delays in delivery of materials or component

equipment that affect progress on a controlling item of work as a basis for granting a time extension if such delays are beyond the control of Contractor or supplier. Such delays may include an area-wide shortage, an industry-wide strike, or a natural disaster that affects all feasible sources of supply. In such cases, Contractor shall furnish substantiating letters from a representative number of manufacturers of such materials or equipment clearly confirming that the delays in delivery were the result of an area-wide shortage, an industry-wide strike, etc. No additional compensation will be made for delays caused by delivery of materials or component equipment.

b. The Department will not consider requests for time extension due to delay in the delivery of custom manufactured equipment including traffic signal equipment, highway lighting equipment, etc., unless Contractor furnishes documentation that the order for such equipment was placed in a timely manner, the delay was caused by factors beyond the manufacturer's control, and the lack of such equipment caused a delay in progress on a controlling item of work. No additional compensation will be paid for delays caused by delivery of custom manufactured equipment.

c. The Department will consider the effect of utility relocation and adjustment work on job progress as the basis for granting a time extension only if all the following criteria are met:

1) Delays are the result of either utility work that was not detailed in the plans, or utility work that was detailed in the plans but was not accomplished in reasonably close accordance with the schedule included in the Contract Documents.

2) Utility work actually affected progress toward completion of controlling work items.

3) Contractor took all reasonable measures to minimize the effect of utility work on job progress, including cooperative scheduling of Contractor's operations with the scheduled utility work at the preconstruction conference and providing adequate advance notification to utility companies as to the dates to coordinate their operations with Contractor's operations to avoid delays.

d. As a condition precedent to an extension of Contract Time, Contractor must submit to Engineer:

1) A preliminary request for an extension of Contract Time made in writing to Engineer within ten calendar days after the commencement of a delay to a controlling item of work. If Contractor fails to submit this required preliminary request for an extension of Contract Time, Contractor fully,

completely, absolutely and irrevocably waives any entitlement to an extension of Contract Time for that delay. In the case of a continuing delay only a single preliminary request for an extension of Contract Time will be required. Each such preliminary request for an extension of Contract Time shall include as a minimum the commencement date of the delay, the cause of the delay, and the controlling item of work affected by the delay; and

- 2) Further, Contractor must submit to Engineer a request for a Contract Time extension in writing within 30 days after the elimination of the delay to the controlling item of work identified in the preliminary request for an extension of Contract Time. Each request for a Contract Time extension shall include as a minimum all documentation that Contractor wishes the Department to consider related to the delay, and the exact number of days requested to be added to Contract Time. If Contractor contends that the delay is compensable, then Contractor is also required to submit with the request for a Contract Time extension a detailed cost analysis of the requested additional compensation. If Contractor fails to submit this required request for a Contract Time extension, with or without a detailed cost analysis, depriving Engineer of the timely opportunity to verify the delay and the costs of the delay, Contractor waives any entitlement to an extension of Contract Time or additional compensation for the delay.
- e. Upon timely receipt of the preliminary request of Contract Time from Contractor, Engineer will investigate the conditions, and if it is determined that a controlling item of work is being delayed for reasons beyond the control of Contractor, Engineer will take appropriate action to mitigate the delay and the costs of the delay. Upon timely receipt of the request for a Contract Time extension Engineer will further investigate the conditions, and if it is determined that there was an increase in the time or the cost of performance of the controlling item of work beyond the control of Contractor, then an adjustment of Contract Time will be made, and a monetary adjustment will be made, excluding loss of anticipated profits, and the Contract will be modified in writing accordingly.
- f. The existence of an accepted schedule, including any required update(s), as required by the Contract Documents is a condition precedent to Contractor having any right to the granting of an extension of contract time or any monetary compensation arising out of any delay. Contractor failure to have an accepted schedule, including any required update(s), for the period of potential impact, or in the event the currently accepted schedule and applicable updates do not

accurately reflect the actual status of the project or fail to accurately show the true controlling or non-controlling work activities for the period of potential impact, will result in any entitlement determination as to time or money for such period of potential impact being limited solely to the Department's analysis and identification of the actual controlling or non-controlling work activities. Further, in such instances, the Department's determination as to entitlement as to either time or compensability will be final.

#### O. Default and Termination of Contract

##### 1. Determination of Default:

- a. The following acts or omissions constitute acts of default and, except as to subparagraph 10) below, the Department will give notice, in writing, to Contractor and his surety for any delay, neglect or default, if Contractor:
  - 1) Fails to begin the work under the Contract within the time specified in the Notice to Proceed;
  - 2) Fails to perform the work with sufficient workmen and equipment or with sufficient materials to ensure prompt completion of the Contract;
  - 3) Performs the work unsuitably, or neglects or refuses to remove materials or to perform anew such work that Engineer rejects as unacceptable and unsuitable;
  - 4) Discontinues the prosecution of the work, or fails to resume discontinued work within a reasonable time after Engineer notifies Contractor to do so;
  - 5) Becomes insolvent or is declared bankrupt, or files for reorganization under the bankruptcy code, or commits any act of bankruptcy or insolvency, either voluntarily or involuntarily;
  - 6) Allows any final judgment to stand against him unsatisfied for a period of ten calendar days;
  - 7) Makes an assignment for the benefit of creditors;
  - 8) Fails to comply with Contract requirements regarding minimum wage payments;
  - 9) Fails to comply with Engineer's written suspension of work order within the time allowed for compliance and which time is stated in that suspension of work order; or
  - 10) For any other cause whatsoever, fails to carry on the work in an acceptable manner, or if the surety executing the bond, for any reasonable cause, becomes unsatisfactory in the opinion of the Department.



- b. For a notice based upon reasons stated in subparagraphs a. 1) through 8) and 10) above: if Contractor, within a period of ten calendar days after receiving the notice described above, fails to correct the conditions of which complaint is made, the Department will, upon written certificate from Engineer of the fact of such delay, neglect, or default and Contractor's failure to correct such conditions, have full power and authority, without violating the Contract, to take the prosecution of the work out of the hands of Contractor and to declare Contractor in default.
- c. If Contractor, after having received a prior notice described above for any reason stated in subparagraph a. 2), 3), 4), 5), 6) or 8), commits a second or subsequent act of default for any reason covered by the same subparagraph a. 2), 3), 4), 5), 6) or 8) as stated in the prior notice, and regardless whether the specific reason is the same, then, regardless of whether Contractor has cured the deficiency stated in that prior notice, the Department will, upon written certificate from Engineer of the fact of such delay, neglect or default and Contractor's failure to correct such conditions, have full power and authority, without any prior written notice to Contractor and without violating the Contract, to take the prosecution of the work out of the hands of Contractor and to declare Contractor in default.
- d. Regarding subparagraph a. 9), if Contractor fails to comply with Engineer's written suspension of work order within the time allowed for compliance and which time is stated in that suspension of work order, the Department will, upon written certificate from Engineer of the fact of such delay and Contractor's failure to correct that condition, have full power and authority, without violating the Contract, to immediately take the prosecution of the work out of the hands of Contractor and to declare Contractor in default.
- e. The Department has no liability for anticipated profits for unfinished work on a Contract that the Department has determined to be in default.

2. Completion of Work by Department:

- a. Upon declaration of default, the Department will have full power to appropriate or use any or all suitable and acceptable materials and equipment on the site and may enter into an agreement with others to complete the work under the Contract, or may use other methods to complete the work in an acceptable manner. The Department will charge all costs that the Department incurs because of Contractor's default, including the costs of completing the work under the Contract, against Contractor. If the Department incurs such costs in an amount

that is less than the sum that would have been payable under the Contract had the defaulting Contractor completed the work then the Department will pay the difference to the defaulting Contractor. If the Department incurs such costs in an amount that exceeds the sum that would have been payable under the Contract, then Contractor and the surety shall be liable and shall pay the County the amount of the excess.

- b. If, after the ten day notice period and prior to any action by the Department to otherwise complete the work under the Contract, Contractor establishes his intent to prosecute the work in accordance with the Department's requirements, then the Department may allow Contractor to resume the work, in which case the Department will deduct from any monies due or that may become due under the Contract, any costs to the County incurred by the delay, or from any reason attributable to the delay.

3. Termination of Contract for Convenience:

- a. The Department may terminate the entire Contract or any portion thereof, if the Department determines termination is in the County's interest. Engineer will deliver to Contractor a Written Notice of Termination specifying the extent of termination and the effective date.
- b. When the Department terminates the entire Contract, or any portion thereof, before Contractor completes all items of work in the Contract, the Department will make payment for the actual number of units or items of work that Contractor has completed, at the Contract unit price, and as approved by Engineer for items of work partially completed, and such payments will constitute full and complete compensation for such work or items. No payment of any kind or amount will be made for items of work not started. The Department will not consider any claim for loss of anticipated profits, or overhead of any kind (including home office and jobsite overhead or other indirect impacts).
- c. The Department will consider reimbursing Contractor for actual cost of mobilization (when not otherwise included in the Contract) including moving equipment to the job where the volume of the work that Contractor has completed is de minimis and thereby too small to compensate Contractor for these expenses under the Contract unit prices.
- d. The Department may purchase at actual cost acceptable materials and supplies procured for the work, that the Department has inspected, tested, and approved and that Contractor has not incorporated in the work. Submit the proof of actual cost, as shown by receipted bills and actual cost records, at

such points of delivery as Engineer may designate.

- e. Termination of a contract or a portion thereof, under the provisions of this Subarticle, does not relieve Contractor or the surety of its responsibilities for the completed portion of the Contract or its obligations for and concerning any just claims arising out of the work performed.

P. Release of Contractor's Responsibility

The Department considers the Contract complete when Contractor has completed all work and requirements of the Contract and the Department has accepted the Work. The Department will then release Contractor from further obligation except as set forth in the Contract Bonds, and except as allowed by the Contract Documents subsequent to Final Payment.

1.07 MEASUREMENT AND PAYMENT

A. Compensation

- 1. Compensation provided by the Contract, through the various scheduled items having awarded Contract Unit Prices, constitutes full payment for completing the Work and meeting all requirements of the Contract Documents. Approved payments will be made only under items having awarded Contract Unit Prices that are measured and accepted by Engineer.
- 2. The aforementioned compensation includes:
  - a. Full payment for furnishing any material, supply, equipment, tool, labor, supervision, or meeting any requirement that is reasonably inferred or incidental to the Work whether or not specifically called for by the Contract Documents.
  - b. Items of work that do not have awarded Contract Unit Prices, even if the items appear within the Articles of these Specifications or anywhere else in the Contract Documents. These items will not be measured separately for payment. Compensation for performing any work or meeting any requirement associated with these items is included in approved payments made under the various scheduled items having awarded Contract Unit Prices.
- 3. For Job Order Contracts, the Contract Unit Price, where referenced anywhere in these Contract Documents, is the price which results from the multiplication of the unit price provided by the County on the Project Bid Form times the awarded Contractor's percentage factor. All compensation for services called for in this Contract shall be made on the basis of the Contract Unit Prices for quantities based upon the actual work performed and accepted by Engineer. Such compensation shall be complete payment for all phases of the operation and no additional payment shall be made for any reason whatsoever.

- 4. Miami-Dade County offers a payment option that will expedite County payments to your organization via Automatic Clearing House transfers instead of the issuance and mailing of a County check. More information is available at <http://www.miamidade.gov/finance/vendor-payment.asp#5> The form can also be found on the Appendices to the Special Provisions

B. Contingency Allowance Account

- 1. A Contingency Allowance account has been established for the Work under this Contract. The Total Contract award amount will include no more than ten percent (10%) Contingency Allowance Account. Contractor is not entitled to funds from the Contingency Allowance Account unless, at the discretion of Engineer, work is directed to be performed that is beyond the scope of established pay items. Contractor shall perform such work only upon receipt of an executed Miami-Dade-County Contingency Allowance Account expenditure form from Engineer.

C. Florida Power And Light Connection Allowance

- 1. County will reimburse Contractor, at invoice cost, for the services of the Florida Power and Light (FPL) connection fees required by Engineer. The necessary invoices shall be submitted to Engineer for inclusion in the payment requisition. This payment will be made from the appropriate dedicated allowance. If no dedicated allowance is provided, then payment shall be made from the Contingency Allowance Account.

D. Retainage; Punch List Requirements

- 1. Amount of retainage.
  - a. An amount of 5-percent retainage will be withheld from each progress payment made to Contractor.
- 2. Project closeout (Punch List).
  - a. Within 21 days of reaching Substantial Completion and performance of required inspection(s), Engineer, with cooperation of Contractor, will develop a single punch list subject to the provisions of Section 218.735 (7) of the Florida Statutes (F.S.), listing all items necessary to render complete, satisfactory, and acceptable to Engineer all work and requirements of the Contract. Contractor will review and comment as necessary to assist Engineer in the preparation of the final draft of the list during the aforementioned timeframe.
  - b. Engineer will provide Contractor with the Punch List within 5 days after the List has been developed and reviewed as provided in Subarticle 2.a above. Contractor must immediately work on completion of the items listed and provide to Engineer within 5 days of receipt of the Punch List, a final schedule for the completion of all pending work and

requirements of the Contract. The schedule must provide for the final completion of all Contract requirements and acceptance by the Engineer prior to the expiration of the Contract.

c. For work order or multiphase projects:

- 1) Provide a punch list listing all items necessary to render complete, satisfactory, and acceptable to Engineer all work and requirements for each phase or work order as applicable.
- 2) All time limitations and requirements stipulated above apply except that the timeframe requirements for the individual punch lists are based on the specific phase or work order's substantial completion.

3. Release of Retainage.

a. The release of retainage is subject to Section 218.735 (7), F.S. and may be requested as follows:

- 1) Upon completion of all items on the punch list and their acceptance by Engineer, Contractor may submit a payment request for all remaining retainage withheld by the County
- 2) under this Contract. If a good faith dispute exists as to whether one or more items identified on the Punch List have been completed pursuant to the Contract requirements, the County may continue to withhold an amount equal to 150 percent of the total costs to complete such items.
- 3) The County is not required to pay or release any amounts of retainage that are the subject of a good faith dispute, the subject of a claim brought pursuant to Section 255.05, F.S., or otherwise the subject of a claim or demand by the County or Contractor.

E. Measurement of Quantities

1. Measurement Standards: Engineer will measure all work completed under the Contract in accordance with the United States Standard Measures.
2. Method of Measurements: Engineer will take all measurements horizontally or vertically as applicable.
3. Determination of Pay Areas:
  - a. Final Calculation: When measuring items paid for on the basis of area of finished work, where the pay quantity is designated to be determined by calculation, Engineer will use lengths and widths in the calculations based on the station to station dimensions shown on the plans; the station to station dimensions actually constructed within the limits designated by Engineer; or the final dimensions measured along the surface of the completed work within the neat lines shown on the Plans or designated by Engineer. Engineer will use the method or

combination of methods of measurement that reflect, with reasonable accuracy, the actual surface area of the finished work as Engineer determines.

4. Construction Outside Authorized Limits: Engineer will not pay for surfaces constructed over a greater area than authorized, or for material that Contractor has moved from outside of slope stakes and lines shown on the plans, except where Engineer provides written instruction for Contractor to perform such work.

5. Truck Requirements: Provide all trucks with numbers and certify that all trucks used have a manufacturer's certification or permanent decal showing the truck capacity rounded to the nearest tenth of a cubic yard placed on both sides of the truck. This capacity will include the truck body only and any side boards added will not be included in the certified truck body capacity. Ensure the lettering and numbers are legible for identification purposes at all times.

6. Ladders and Instrument Stands for Bridge Projects:

- a. On bridge projects, in order to facilitate necessary measurements, provide substantial ladders to the tops of piers and bents, and place and move such ladders as Engineer directs.
- b. For bridge projects crossing water or marshy areas, supply fixed stands for instrument mounting and measurements, in accordance with the details stipulated in the Specifications for the project.

F. Fuel Adjustment

1. DTPW will, in the Contract Documents, provide an estimated quantity for fuel requirements for diesel to cover the Work specified in the Contract. Price adjustments will be made only for the amount of diesel fuel estimated by the DTPW required to complete the Contract. The requirement of fuel for each pay item is estimated by multiplying FDOT's standard fuel factor for that pay item by the quantity of that pay item. On Contracts with an original Contract Time in excess of 120 calendar days, DTPW will make price adjustments on each applicable progress estimate to reflect increases or decreases in the price of diesel from those in effect during the month in which bids were received. The Contractor will not be given the option of accepting or rejecting these adjustments. Price adjustments for fuel will be made only when the current fuel price (CFP) varies by more than 5% from the price prevailing in the month when bids were received (BFP), and then only on the portion that exceeds 5%.

2. Price adjustments will be based on the monthly bulk average price for diesel as derived by FDOT. These average indexes shall be determined by averaging bulk fuel prices on the first day of each month as quoted by major oil companies that are reasonably expected to furnish fuel for projects in the State of Florida. Average price indices for will be available on FDOT Construction Office website before the 15th of each month, at the following URL:

<https://www.fdot.gov/construction/fuel-bit/fuel-bit.shtm>.

3. Payment will be based on the quantities shown on the progress estimate on all items for which established standard fuel factors are on a file maintained by DTPW. Payment on progress estimates will be adjusted to reflect adjustments in the prices for diesel in accordance with the following:

a. When fuel prices have decreased between month of bid and month of this progress estimate:

- 1)  $A_i = F_i (P_i - 0.95 P_b)$  during a period of decreasing prices.
- 2)  $A_i =$  Total dollar amount - positive or negative - of the cost adjustment for fuel used by the Contractor during the month "i."
- 3)  $F_i =$  Total gallons calculated as being used during the month.
- 4)  $P_i =$  Average price for fuel prevailing during month "i."
- 5)  $P_b =$  Average price for fuel prevailing during the month "b" when bids were received on this Contract.

b. When fuel prices have increased between month of bid and month of this progress estimate:

- 1)  $A_i = F_i (P_i - 1.05 P_b)$  during a period of increasing prices.
- 2)  $A_i =$  Total dollar amount - positive or negative - of the cost adjustment for fuel used by the Contractor during the month "i."
- 3)  $F_i =$  Total gallons calculated as being used during the month.
- 4)  $P_i =$  Average price for fuel prevailing during month "i."
- 5)  $P_b =$  Average price for fuel prevailing during the month "b" when bids were received on this Contract

4. Payment will be made on the current progress estimate to reflect the index difference at the time Work was performed.

5. Adjustments will be paid or charged to the Prime Contractor only. Any Contractor receiving an adjustment under this provision shall distribute the proper proportional part of such adjustment to subcontractors who perform applicable Work

G. Bituminous Material

a. On Contracts having an original Contract Time of more than 365 calendar days, or more than 5,000 tons of asphalt concrete, the Department will adjust the bid unit price for bituminous material, excluding cutback and emulsified asphalt to reflect increases or decreases in the Asphalt Price Index (API) of bituminous material from that in effect during

the month in which bids were received. Contractor will not be given the option of accepting or rejecting this adjustment. Bituminous adjustments will be made only when the current API (CAPI) varies by more than 5% of the API prevailing in the month when bids were received (BAPI), and then only on the portion that exceeds 5%.

b. The Department will use the API determined by FDOT and available on the FDOT Office of Construction website L: <https://www.fdot.gov/construction/fuel-bit/fuelbit.shtm>.

c. Payment on progress estimates will be adjusted to reflect adjustments in the prices for bituminous materials in accordance with the following:

- 1) \$ Adjustment = (ID)(Gallons)
- 2) Where ID = Index Difference = [CAPI - 0.95(BAPI)] when the API has decreased between the month of bid and month of this progress estimate.
- 3) Where ID = Index Difference = [CAPI - 1.05(BAPI)] when the API has increased between the month of bid and month of this progress estimate.
- 4) Payment will be made on the current progress estimate to reflect the index difference at the time work was performed.
- 5) For asphalt concrete items payable by the ton, the number of gallons will be determined assuming a mix design with 6.25 percent liquid asphalt weighing 8.58 lb/gal.
- 6) Asphalt concrete items payable by the square yard will be converted to equivalent tons assuming a weight of 100 lb/yd<sup>2</sup> per inch.

2. Non-Duplication of Payment: In cases where the basis of payment clause in these Specifications relating to any unit price in the bid schedule requires that the unit price cover and be considered compensation for certain work or material essential to the item, the Department will not measure or pay for this same work or material under any other pay item that may appear elsewhere in these Specifications.

H. Material Adjustments for Aluminum, PVC, and Copper.

1. DTPW will make price adjustments for aluminum, PVC, and copper materials included in the Contract pay item list in accordance with the following procedures:

a. Prepare separate Contractor's Certification of Quantities for each material invoice month using the FDOT forms for Material Price Adjustment. <https://www.fdot.gov/construction/material-price-adjustment>.

b. Submit certifications for materials purchased. Submit certifications for subsequent estimate

periods as directed by the Engineer, based on the quantity of each material purchased within the estimate period. Material certifications reflecting quantities beyond the final contract quantity shall not be accepted. Ensure each certification includes the Contract Number, Certification Date and Number, the period the certification represents, and the quantity represented by each invoice for each pay item. Submit material invoices with each certification and clearly identify the following:

- 1) Pay Item Number
  - 2) Certification Quantity
  - 3) Invoice Number
  - 4) Invoice Date
  - 5) Invoice Quantity
  - 6) Invoice Unit Price
  - 7) Invoice Total
2. On Contracts with an original Contract Time of more than 120 days, DTPW will adjust the unit price to reflect increases or decreases in material costs from those in effect during the month in which bids were received. The contractor will not be given the option of accepting or rejecting these adjustments. Price adjustments will be made only when the invoice month material price index (IMP) varies by more than 5% from the price index prevailing in the month when the bids were received (BMP), and then only on the portion that exceeds 5%.
3. DTPW will use factors to determine the percentage of unit price applicable to material only. Price Adjustments will be based on the USDOL monthly Producer Price Index (PPI). The Material Price indices will be available on the FDOT Construction Office website before the 15th of each month at the following website: <https://www.fdot.gov/construction/material-priceadjustment>
4. Payment on progress estimates will be adjusted to reflect adjustments in the prices for aluminum, PVC, and copper materials in accordance with the following:
- a.  $\$ \text{ Adjustment} = (\text{quantity})(\text{unit price})(\text{material factor})(\text{ID})$
  - b. Where  $\text{ID} = \text{Index \% Difference} = [\text{IMP} - 0.95(\text{BMP})] / \text{BMP}$  when the IMP has decreased between the month of bid and the month of material invoice.
  - c. Where  $\text{ID} = \text{Index \% Difference} = [\text{IMP} - 1.05(\text{BMP})] / \text{BMP}$  when the IMP has increased between the month of bid and the month of material invoice.
5. A line-item adjustment will be made on the last progress estimate prior to the final estimate to each applicable pay item to reflect the cumulative value of all Contractor Certification of Quantities submitted throughout the duration of the contract.

6. Adjustments will be paid or charged to the Prime Contractor only. Any Contractor receiving an adjustment under this provision for work performed by a subcontractor shall distribute such adjustment to subcontractors who perform applicable work.
7. DTPW reserves the right to audit the Contractor's records pertaining to the material certifications submitted for this Contract.
1. Material Adjustments for Steel Guardrail
1. DTPW will make price adjustments for steel guardrail materials included in the Contract pay item list in accordance with the following procedures:
  2. Prepare separate Contractor's Certification of Quantities for each material invoice month using the FDOT form for Material Price Adjustment. <https://www.fdot.gov/construction/material-price-adjustment>.
  3. Submit certifications for materials purchased. Submit certifications for subsequent estimate periods as directed by the Engineer, based on the quantity of each material purchased within the estimate period. Material certifications reflecting quantities beyond the final contract quantity shall not be accepted. Ensure each certification includes the Contract Number, Certification Date and Number, the period the certification represents, and the quantity represented by each invoice for each pay item. Submit material invoices with each certification and clearly identify the following:
  4. Pay Item Number
  5. Certification Quantity
  6. Invoice Number
  7. Invoice Date
  8. Invoice Quantity
  9. Invoice Unit Price
  10. Invoice Total
  11. On Contracts with an original Contract Time of more than 120 days, DTPW will adjust the unit price to reflect increases or decreases in material costs from those in effect during the month in which bids were received. The contractor will not be given the option of accepting or rejecting these adjustments. Price adjustments will be made only when the invoice month material price index (IMP) varies by more than 5% from the price index prevailing in the month when the bids were received (BMP), and then only on the portion that exceeds 5%.
  12. DTPW will use factors to determine the percentage of unit price applicable to material only. Price Adjustments will be based on the USDOL monthly Producer Price Index (PPI). The Material Price indices will be available on the FDOT Construction Office website before the 15th of each month at the following website: <https://www.fdot.gov/construction/material-price-adjustment>.

13. Payment on progress estimates will be adjusted to reflect adjustments in the prices for aluminum, PVC, and copper materials in accordance with the following:
  - a.  $\$ \text{ Adjustment} = (\text{quantity})(\text{unit price})(\text{material factor})(\text{ID})$
  - b. Where  $\text{ID} = \text{Index \% Difference} = [\text{IMP} - 0.95(\text{BMP})] / \text{BMP}$  when the IMP has decreased between the month of bid and the month of material invoice.
  - c. Where  $\text{ID} = \text{Index \% Difference} = [\text{IMP} - 1.05(\text{BMP})] / \text{BMP}$  when the IMP has increased between the month of bid and the month of material invoice.
14. : A line-item adjustment will be made on the last progress estimate prior to the final estimate to each applicable pay item to reflect the cumulative value of all Contractor Certification of Quantities submitted throughout the duration of the contract.
15. Adjustments will be paid or charged to the Prime Contractor only. Any Contractor receiving an adjustment under this provision for work performed by a subcontractor shall distribute the proper proportional part of such adjustment to subcontractors who perform applicable work.
16. DTPW reserves the right to audit the Contractor's records pertaining to the material certifications submitted for this Contract.

J. Lump Sum Quantities

1. Error in Lump Sum Quantity: Where the Department designates the pay quantity for an item to be a lump sum and the plans show an estimated quantity, the Department will adjust the lump sum compensation only in the event that either Contractor submits satisfactory evidence or the Department determines from satisfactory evidence that a difference exists between the original plan quantity and final quantity of greater than 5 percent.
2. Authorized Changes in Work: Where the Department designates the pay quantity for an item to be a lump sum and the plans show an estimated quantity, the Department will adjust compensation for that item proportionately when an authorized plan change is made which results in an increase or decrease in the quantity of that item. When the plans do not show an estimated plan quantity or the applicable specifications do not provide adjustments for contingencies, the Department will compensate for any authorized plan change resulting in an increase or decrease in the cost of acceptably completing the item by establishing a new unit price through a Change Order.

K. Deleted Work

1. The Department will have the right to cancel the portions of the Contract relating to the construction of any acceptable item therein, by the payment to Contractor of a fair and equitable amount covering all items of cost incurred prior to the date that Engineer cancels the work.

L. Partial Payments

1. General:

- a. Engineer will make partial payments on monthly estimates based on the amount of work that Contractor completes during the month (including delivery of certain materials, as specified herein below). Engineer will make approximate monthly payments, and the Department will correct all partial estimates and payments in the subsequent estimates and in the final estimate and payment.
  - b. The Department will base the amount of such payments on the total value of the work that Contractor has performed to the date of the estimate, based on the quantities completed as determined by Engineer and the Contract prices, less payments previously made and less any retainage withheld.
2. Withholding Payment for Defective Work: If the Department discovers any defective work or material prior to the final acceptance, or if the Department has a reasonable doubt as to the integrity of any part of the completed work prior to final acceptance, then the Department will not allow payment for such defective or questioned work until Contractor has remedied the defect and removed any causes of doubt.

3. Partial Payments for Delivery of Certain Materials:

a. General:

- 1) The Department may allow partial payments for new materials that will be permanently incorporated into the Project and are stockpiled in approved locations in the project vicinity. Stockpile materials so that they will not be damaged by the elements.
- 2) The following conditions apply to all partial payments for stockpiled materials:
  - a) There must be reasonable assurance that the stockpiled material will be incorporated into the Project.
  - b) The stockpiled material must be approved by Engineer as meeting applicable specifications.
  - c) The total quantity for which partial payment is made shall not exceed the estimated total quantity required to complete the Project.
  - d) Contractor must furnish Engineer with copies of certified invoices to document the value of the materials received. The amount of the partial payment will be determined from invoices for the material up to the unit price in the Contract.
  - e) Delivery charges for materials delivered to the jobsite will be included in partial payments if properly documented.
  - f) Partial payments will not be made for materials which were stockpiled prior to award of the Contract for a project.

b. Partial Payment Amounts: The following partial payment restrictions apply:

- 1) Partial payments less than \$5,000 for any one month will not be processed.
- 2) Partial payments for structural steel and precast prestressed items will not exceed 85% of the Contract price for the item. Partial payments for all other items will not exceed 75% of the Contract price of the item in which the material is to be used.
- 3) Partial payment will not be made for aggregate and base course material received after paving or base construction operations begin except when a construction sequence designated by the Department requires suspension of paving and base construction after the initial paving operations, partial payments will be reinstated until the paving and base construction resumes.

4. Certification of Payment to Subcontractors:

- a. The term "subcontractor," as used herein, includes persons or firms furnishing materials or equipment incorporated into the work or stockpiled for which the Department has made partial payment and firms working under equipment-rental agreements. Contractor is required to pay all subcontractors for satisfactory performance of their Contracts before the Department will make a further progress (partial) payment. Contractor shall also return all retainage withheld to the subcontractors within 30 days after the subcontractor's work is satisfactorily complete, as determined by the Department. Prior to receipt of any progress (partial) payment, Contractor shall certify that all subcontractors having an interest in the Contract were paid for satisfactory performance of their contracts and that the retainage is returned to subcontractors within 30 days after satisfactory completion of the subcontractor's work. Provide this certification in the form designated by the Department.
- b. Within 30 days of Contractor's receipt of the final progress payment or any other payments thereafter, except the final payment, Contractor shall pay all subcontractors and suppliers having an interest in the Contract for all work completed and materials furnished. The Department will honor an exception to the above when Contractor demonstrates good cause for not making any required payment and furnishes written notification of any such good cause to both the Department and the affected subcontractors or suppliers within said 30-day period.

1. General: For all construction materials used in the construction of the Project, (except materials for materially generally classed as non-commercial), preserve for the Department's inspection the invoices and records of the materials for a period of five years from the date of completion of the Project. Apply this requirement when subcontractors purchase materials, and obtain the invoices and other materials records from the subcontractors. By providing the materials, Contractor certifies that all invoices will be maintained for the required period.

N. Recovery Rights, Subsequent to Final Payment

1. The Department reserves the right, if it discovers an error in the partial or final payments, or if it discovers that Contractor performed defective work or used defective materials, after the final payment has been made, to claim and recover from Contractor or his surety, or both, by process of law, such sums as may be sufficient to correct the error or make good the defects in the work and materials.
2. Retain all records pertaining to the Project for a period of five years from the date of Engineer's final acceptance of the Project and final payment, or greater if required by record retention laws. Upon request, make all such records available to the Department or its representative. For the purpose of this Article, records include all books of account, supporting documents, and papers that the Department deems necessary to ensure compliance with the Contract provisions.

M. Record of Construction Materials

# CONSTRUCTION SPECIFICATIONS



SPECIFICATIONS  
TABLE OF CONTENTS

**DIVISION 100 GENERAL CONSTRUCTION OPERATIONS**

---

101	MOBILIZATION (REV. 03-12-2013).....	1
	A. Description.....	1
	B. Basis of Payment.....	1
102	MAINTENANCE OF TRAFFIC (REV. 12-15-2015).....	1
	A. Description.....	1
	B. Materials.....	2
	C. Worksite Traffic Supervisor.....	2
	D. Submittals.....	2
	E. Traffic Control.....	3
	F. Detours.....	4
	G. Traffic Control Officer.....	5
	H. Driveway Maintenance.....	5
	I. Temporary Traffic Control Devices.....	5
	J. Work Zone Pavement Marking.....	8
	K. Method of Measurement.....	8
	L. Submittals.....	10
	M. Basis of Payment.....	11
104	PREVENTION, CONTROL, AND ABATEMENT OF EROSION AND WATER POLLUTION (REV. 01-09-12).....	12
	A. Description.....	12
	B. General.....	12
	C. Control of Contractor's Operations Which May Result in Water Pollution.....	13
	D. Materials for Temporary Erosion Control.....	13
	E. Erosion Control Plan.....	13
	F. Construction Requirements.....	14
	G. Maintenance of Erosion and Sediment Control Features.....	16
	H. Protection During Suspension of Contract Time.....	16
	I. Method of Measurement.....	16
	J. Basis of Payment.....	16
105	CONTRACTOR QUALITY CONTROL GENERAL REQUIREMENTS (REV. 08-23-12).....	16
	A. General.....	16
	B. Guidelines for Development of the CQCP.....	17
	C. Quality Control Plan Submittal.....	18
	D. Quality Control Documentation.....	18
	E. Contractor Certification of Compliance.....	19
	F. Personnel Qualifications.....	19
	G. FDOT Quality Control Program.....	24
107	LITTER REMOVAL AND MOWING (REV. 11-25-2015).....	24
	A. Description.....	24
	B. Operation.....	24
	C. Method of Measurement.....	25
	D. Basis of Payment.....	25
110	CLEARING AND GRUBBING (REV. 05-16-11).....	25
	A. General.....	25
	B. Clearing and Grubbing.....	25

C. Ownership of Materials .....27  
D. Disposal of Materials. ....27  
E. Method of Measurement .....28  
F. Basis of Payment .....29

**101 MOBILIZATION (REV. 03-12-2013)**

A. Description.

1. Perform preparatory work and operations in mobilizing for beginning work on the Project, including, but not limited to, those operations necessary for the movement of personnel, equipment, supplies, and incidentals to the project site(s) and for the establishment of temporary offices, buildings, safety equipment and first aid supplies, and sanitary and other facilities.
2. Include the costs of bonds and any required insurance and any other preconstruction expense necessary for the start of the work, excluding the cost of construction materials.

B. Basis of Payment.

1. When No Separate Item for Mobilization is Included in the Contract:
  - a. All work and incidental costs specified as being covered under this Article will be included for payment under the several scheduled items of the overall Contract, and no separate payment will be made therefore.
2. When a Separate Pay Item for Mobilization is Included in the Contract:
  - a. The work and incidental costs specified as being covered under this Article will be paid for at the Contract lump sum price for the Mobilization pay item, after an executed Notice to Proceed has been issued, by partial payments made in accordance with the following:
    - 1) For contracts of 120 contract days duration or less, partial payment will be made at 50% of the bid price per month for the first two months. For contracts in excess of 120 contract days duration, partial payment will be made at 25% of the bid price per month for the first four months. In no event shall more than 50% of the bid price be paid prior to commencing construction on the project site.
    - 2) Total partial payments for Mobilization on any project, including when more than one project or job is included in the Contract, will be limited to 10% of the original Contract amount for that project. Any remaining amount will be paid upon completion of all work on the Contract.
    - 3) Retainage, as specified in the Contract Documents, will be applied to all partial payments.
    - 4) Partial payments made on this Subarticle will in no way act to preclude or limit any of the provisions for partial payments otherwise provided for by the Contract.

3. Basis of Payment:

a. Payment will be made under:

Item #	Description	Unit
101-1-A	Mobilization	Lump Sum

**102 MAINTENANCE OF TRAFFIC (REV. 12-15-2015)**

A. Description.

1. General:

- a. Maintain, for the duration of the construction period including any temporary suspensions of the Work, all traffic including pedestrian traffic within the limits of the Project starting the day work begins on the Project or the first day Contract time is charged, or on the day work begins on the work order, whichever is earlier .
- b. Construct and maintain detours.
- c. Provide facilities for access to residences, businesses, etc., along the Project.
- d. Furnish, install and maintain traffic control and safety devices during construction in accordance with FDOT Index 600 Series of the FDOT Design Standards, or as directed by Engineer. MOT includes all facilities, devices and operations as required for safety and convenience of the public within the work zone. Provide pickup, removal and disposal of litter and mow turf or vegetation within the MOT limits as required by Article 107.
- e. Furnish and install work zone pavement markings for maintenance of traffic (MOT) in construction areas.
- f. Provide any other special requirements for safe and expeditious movement of traffic specified in the Plans or directed by Engineer.

2. Unless otherwise directed by Engineer or required by the Contract Documents, do not maintain traffic over those portions of the Project where no work is to be accomplished or where construction operations will not affect existing roads including sidewalks.
3. Do not obstruct or create a hazard to any traffic during the performance of the Work and repair any damage to existing pavement open to traffic.
4. Traffic may be detoured only upon approval by the County Engineer. Contractor must submit for review and approval an updated MOT plan prior to closure of any roads.
5. The Department may temporarily suspend all activities, except traffic, erosion control and such other activities that are necessary for project maintenance and safety, for failure to comply with these provisions.
6. Due to traffic congestion, work hours other than normal established hours may be required by the Engineer. In the case of extreme traffic or weather conditions, Contractor may be required to remove their operation from the roadway and/or right of way, at the discretion of the Engineer or the Traffic Control Officer at no additional compensation.

## B. Materials.

### 1. Meet the following requirements:

Bituminous Adhesive	FDOT Section 970
Temporary Retroreflective Markers	FDOT Section 990
Paint	FDOT Section 971
Removable Tape	FDOT Section 990
Glass Spheres	FDOT Section 971
Temporary Traffic Control Device Materials	FDOT Section 990
Retroreflective and Nonreflective Sheeting for Temporary Traffic Control Devices	FDOT Section 994

2. Temporary Traffic Control Devices: Use only the materials meeting the requirements of FDOT Section 990, FDOT Section 994, FDOT Design Standards and the Manual on Uniform Traffic Control Devices (MUTCD).
3. Detour: Provide all materials for the construction and maintenance of all detours.
4. Commercial Materials for Driveway Maintenance: Provide materials of the type typically used by FDOT for roadway base construction, including reclaimed asphalt pavement material, and having stability and drainage properties that will provide a firm surface under wet conditions.

## C. Worksite Traffic Supervisor.

1. Provide a worksite traffic supervisor meeting the requirements of Article 105. Provide the worksite traffic supervisor with all equipment and materials needed to set up, take down, maintain traffic control, and handle traffic-related situations.
2. Ensure that the worksite traffic supervisor performs the following duties:
  - a. On site direction of all traffic control on the Project.
  - b. Is on site during all MOT set up and take down and performs a drive through inspection immediately after set up.
  - c. Is on site during all nighttime operations to ensure proper MOT.
  - d. Immediately corrects all safety deficiencies and does not permit minor deficiencies that are not immediate safety hazards to remain uncorrected for more than 24 hours.
  - e. Is available on a 24 hour per day basis and present within 45 minutes after notification of an emergency situation and is prepared to positively respond to repair the work zone traffic control or to provide alternate traffic arrangements.
  - f. Conducts daily daytime and weekly nighttime inspections of projects with predominately daytime work activities, and daily nighttime and weekly daytime inspections of projects with predominantly nighttime work activities of all traffic control devices, traffic flow, pedestrian, bicyclist, and business accommodations.

Advise Engineer and the Project personnel of the schedule of these inspections and give them the opportunity to join in the inspection as is deemed necessary.

3. The Department may disqualify and remove from the Project a worksite traffic supervisor who fails to comply with the provisions of this Article.

## D. Submittals

### 1. Traffic Control Plan

- a. Submit at Contractor's own expense a Traffic Control Plan (TCP) for approval by the County when a final TCP was not provided by the County as part of the original Contract Documents. Sequence the Work in a manner that will minimize disruption of vehicular and pedestrian access through and around the Project's construction area(s).
- b. The TCP must detail procedures and protective measures proposed by Contractor to provide for protection and control of traffic affected by the Work consistent with the following applicable standards:
  - 1) The Contract Documents;
  - 2) "Manual on Uniform Traffic Control Devices for Streets and Highways" (MUTCD) and subsequent revisions and addendums, as published by the U.S. Department of Transportation, Federal Highway Administration;
  - 3) The 600 Series indices of the FDOT Design Standards for Design, Construction, Maintenance and Utility Operations on the State Highway System; and
  - 4) The Miami-Dade County Public Works Manual.
- c. All references to the respective agencies in the above referenced standards shall be construed to also include more stringent requirements of the jurisdictional municipality as applicable for this Work.
- d. The TCP must be signed and sealed by a Professional Engineer registered in the state of Florida and shall include proposed locations and time durations of the following, as applicable:
  - 1) Pedestrian and public vehicular traffic routing.
  - 2) Lane and sidewalk closures, other traffic blockage and lane restrictions and reductions anticipated to be caused by construction operations. Show and describe the proposed location, dates, hours and duration of closure, vehicular and pedestrian traffic routing and management, traffic control devices for implementing pedestrian and vehicular movement around the closures, and details of barricades.
  - 3) Location, type and method of shoring to provide lateral support to the side of an excavation or embankment parallel to an open travel-way.
  - 4) Allowable on-street parking within the immediate vicinity of worksite.
  - 5) Access to buildings immediately adjacent to worksite.

- 6) Driveways blocked by construction operations.
  - 7) Temporary traffic control devices, temporary pavement striping and marking of streets and sidewalks affected by construction
  - 8) Temporary commercial and industrial loading and unloading zones.
  - 9) Construction vehicle reroutes, travel times, staging locations, and number and size of vehicles involved.
- e. Obtain and submit prior to erection, or otherwise impacting traffic, all required permits from all authorities having jurisdiction, including the Department, if applicable.
2. Alternative Traffic Control Plan.
    - a. Where a TCP is provided by the County with the Contract Documents, Contractor may still propose an alternative TCP to the plan presented in the Contract Documents. Prepare the TCP in conformance with the requirements stipulated in this Specification and in the form outlined in the current version of FDOT's Plans Preparation Manual. Indicate in the plan a TCP for each phase of activities. Have Contractor's Engineer of Record sign and seal the alternative plan. Take responsibility for identifying and assessing any potential impacts to a utility that may be caused by the alternate TCP proposed by Contractor and
    - b. notify the Department in writing of any such potential impacts to utilities.
    - c. Engineer's approval of the alternate TCP does not relieve Contractor of sole responsibility for all utility impacts, costs, delays or damages, whether direct or indirect, resulting from Contractor initiated changes in the design or construction activities from those in the original Contract Specifications, Design Plans (including TCPs) or other Contract Documents and which effect a change in utility work different from that shown in the Utility Plans, joint project agreements or utility relocation schedules.
    - d. The Department reserves the right to reject any alternative TCP. Obtain Engineer's written approval before beginning work using an alternate TCP. Engineer's written approval is required for all modifications to the TCP. Engineer will only allow changes to the TCP in an emergency without the proper documentation.
  3. Comprehensive Weekly Report:
    - a. Submit to Engineer a comprehensive weekly report of the daily inspections performed and detailing the condition of all traffic control devices (including pavement markings) being used.
    - b. Include assurances in the report that pedestrians are accommodated with a safe, accessible travel path around work sites separated from mainline traffic in compliance with the Americans with Disabilities Act (ADA) Standards for Transportation Facilities, that existing or detoured bicyclist paths are being maintained satisfactorily throughout the Project limits, and that existing businesses in work areas are being provided with adequate entrances for vehicular and pedestrian traffic during business hours.
  - c. When deficiencies are found, the worksite traffic supervisor is to note such deficiencies and include the proposed or implemented corrective actions, including the date corrected.
  - d. Have the worksite traffic supervisor sign the report and certify that all of the above issues are being handled in accordance with the Contract Documents.
    - E. Traffic Control.
      1. Standards: FDOT Design Standards are the minimum standards for the use in the development of all TCPs. The MUTCD, Part VI is the minimum national standard for traffic control for highway construction, maintenance, and utility operations. Follow the basic principles and minimum standards contained in these documents for the design, application, installation, maintenance, and removal of all traffic control devices, warning devices and barriers which are necessary to protect the public and workers from hazards within the Project limits.
      2. Maintenance of Roadway Surfaces:
        - a. Maintain all lanes that are being used for the MOT, including those on detours and temporary facilities, under all weather conditions. Keep the lanes reasonably free of dust, potholes and rutting. Provide the lanes with the drainage facilities necessary to maintain a smooth riding surface under all weather conditions.
      3. Number of Traffic Lanes:
        - a. Maintain one lane of traffic in each direction.
        - b. Maintain two lanes of traffic in each direction at existing four (or more) lane cross roads, where necessary to avoid undue traffic congestion.
        - c. Construct each lane used for MOT at least as wide as the traffic lanes existing in the area before commencement of construction.
        - d. Do not allow traffic control and warning devices to encroach on lanes used for MOT.
        - e. Engineer may allow Contractor to restrict traffic to one-way operation for short periods of time provided that Contractor employs adequate means of traffic control and does not unreasonably delay traffic. When a construction activity requires restricting traffic to one-way operations, locate the flaggers within view of each other when possible. When visual contact between flaggers is not possible, equip them with 2-way radios, official, or pilot vehicles, or use traffic signals.
      4. Crossings and Intersections:
        - a. Provide and maintain adequate accommodations for intersecting and crossing traffic. Do not block or unduly restrict any road or street crossing the Project unless approved by Engineer. Before beginning any construction, provide Engineer the names and phone numbers of persons that can be contacted when signal operation malfunctions.
      5. Access for Residences and Businesses: Provide continuous access to all residences and all places of business.

6. Protection of the Work from Injury by Traffic: Where traffic would be injurious to a base, surface course, or structure constructed as a part of the work, maintain all traffic outside the limits of such areas until the potential for injury no longer exists.
  7. Flagger: Provide trained flaggers in accordance with Article 105.
  8. Conflicting Pavement Markings:
    - a. Where the lane use or where normal vehicle or pedestrian paths are altered during construction, remove all pavement markings (paint, tape, thermoplastic, raised pavement markers, etc.) that will conflict with the adjusted vehicle or pedestrian paths. Use of paint to cover conflicting pavement markings is prohibited. Remove conflicting pavement markings using a method that will not damage the surface texture of the pavement and which will eliminate the previous marking pattern regardless of weather and light conditions.
    - b. Remove all pavement markings that will be in conflict with "next phase of operation" vehicle pedestrian paths as described above, before opening to vehicle traffic or use by pedestrians.
    - c. Cost for removing conflicting pavement markings (paint, tape, thermoplastic, raised pavement markers, etc.) to be included in the Project costs for Maintenance of Traffic (General).
  9. Vehicle and Equipment Visibility:
    - a. Equip all pickups and automobiles used on the Project with a minimum of one Class 2 amber or white warning light that meets the Society of Automotive Engineers Recommended Practice SAE J595, dated November 1, 2008, or SAE J845, dated December 1, 2007, and incorporated herein by reference. Existing lights that meet SAE J845, dated March, 1992, or SAE J1318, dated April, 1986, may be used to its end of service life. Warning lights shall be a high intensity amber or white rotating, flashing, oscillating or strobe light. Lights should be unobstructed by ancillary vehicle equipment such as ladders, racks or booms. If the light is obstructed, additional lights will be required. The lights shall be operating when a vehicle is in a work area where a potential hazard exists, when operating the vehicle at less than the average speed for the facility while performing work activities, making frequent stops or called for in the Plans or FDOT Design Standards.
    - b. Equip all other vehicles and equipment with a minimum of 4 square feet of retroreflective sheeting or flashing lights.
    - c. To avoid distraction to motorists, do not operate the lights on the vehicles or equipment when the vehicles are outside the clear zone or behind a barrier.
  10. No Waiver of Liability: Conduct operations in such a manner that no undue hazard results due to the requirements of this Article. The procedures and policies described herein in no way acts as a waiver of any terms of the liability of Contractor or his surety.
- F. Detours.
1. General: Construct and maintain detour facilities wherever it becomes necessary to divert traffic from any existing roadway or bridge, or wherever construction operations block the flow of traffic.
  2. Construction: Plan, construct, and maintain detours for the safe passage of traffic in all conditions of weather. Provide the detour with all facilities necessary to meet this requirement. Where pedestrian facilities are detoured, blocked or closed during the work, provide safe alternate accessible routes through or around the work zone meeting the requirements of the ADA Standards for Transportation Facilities.
  3. Construction Methods: Select and use construction methods and materials that provide a stable and safe detour facility. Construct the detour facility to have sufficient durability to remain in good condition, supplemented by maintenance, for the entire period that the detour is required.
  4. Removal of Detours: Remove detours when they are no longer needed and before the Contract is completed. Take ownership of all materials from the detour and dispose of them, except for the materials on loan from the Department with the stipulation that they are returned.
  5. Detours Over Existing Roads and Streets: When the Department specifies that traffic be detoured over roads or streets outside the Project area, do not maintain such roads or streets. However, maintain all signs and other devices placed for the purpose of the detour.
  6. Operation of Existing Movable Bridges:
    - a. At the pre-construction meeting, the Engineer and the Contractor will select a date for the County to turn over the bridge maintenance and operations responsibilities. In the event that this date is not discussed, the Contractor will take full responsibility at the NTP date.
    - b. In addition to bridge maintenance responsibilities during the duration of the project, Contractor is responsible for having qualified and sufficient number of bridge operators to be able to operate the bridge in accordance USCG regulations – specifically, Title 33- Navigation and Navigable Waters, Chapter I - U.S. Coast Guard, Department of Homeland Security, Subchapter J-Bridges, Part 117--Drawbridge Operation Regulations, Subpart B--Specific Requirements § 117.5.
    - c. County's bridge operators are scheduled as follows:
 

1st Shift:	12am to 8am
2nd Shift:	8am to 4pm
3rd Shift:	4pm to 12am
    - d. This allows the bridge to be operational on a 7 days/week, 365 days per year basis.
    - e. When removing bridges: Once the bridge is removed Contractor is relieved of this responsibility; however, upon completion of the construction of the new bridge and until the new bridge is officially returned to the County, the contractor is obligated to operate the bridge in accordance with the established USCG regulation.
    - f. Make immediate repairs of any damage to such structures caused by use or operations related to the

work at no expense to the County, but do not provide routine repairs or maintenance. In the event that use or operations result in damage to a bridge requiring repairs, give such repairs top priority to any equipment, material, or labor available.

G. Traffic Control Officer.

1. Provide uniformed law enforcement officers, including marked law enforcement vehicles, to assist in controlling and directing traffic in the work zone as required by Engineer and when the following types of work is necessary on projects:
  - a. Directing traffic/overriding the signal in a signalized intersection.
  - b. When FDOT Design Standards, Index No. 655 Traffic Pacing for overhead work is called for in the Plans or approved by Engineer.
  - c. When pulling conductor/cable above an open traffic lane on limited access facilities, when called for in the Plans or approved by Engineer.
  - d. When FDOT Design Standards, Index No. 625 Temporary Road Closure 5 Minutes or Less is used.

H. Driveway Maintenance.

1. General: Ensure that each residence and business has safe, stable, and reasonable access.
2. Construction Methods:
  - a. Place, level, manipulate, compact, and maintain the material, to the extent appropriate for the intended use.
  - b. As permanent driveway construction is accomplished at a particular location, Contractor may salvage and reuse previously placed materials that are suitable for reuse on other driveways.

I. Temporary Traffic Control Devices.

1. Installation and Maintenance:
  - a. Install and maintain temporary traffic control devices as detailed in the Plans, Index 600 of the FDOT Design Standards and when applicable, in accordance with the approved vendor drawings, as provided on FDOT's Approved Products List (APL) and the TSSQPL. Erect the required temporary traffic control devices to prevent any hazardous conditions and in conjunction with any necessary traffic re-routing to protect the traveling public, workers, and to safeguard the work area. Use only those devices that are on the FDOT APL and the TSSQPL. Immediately remove or cover any devices that do not apply to existing conditions.
  - b. All temporary traffic control devices must meet the requirements of National Cooperative Highway Research Program Report 350 (NCHRP 350) or the Manual for Assessing Safety Hardware 2009 (MASH) and current FHWA directives.
  - c. For devices requiring field assembly or special site preparation, vendor drawings shall include all field assembly details and technical information necessary for proper application and installation and must be

signed and sealed by a Professional Engineer registered in the State of Florida.

- d. Ensure that the FDOT APL number is permanently marked on the device at a readily visible location. Sheeting used on devices is exempt from this marking requirement.
- e. Notify Engineer of any scheduled operation which will affect traffic patterns or safety sufficiently in advance of commencing such operation to permit his review of the plan for the proposed installation of temporary traffic control devices.
- f. Ensure an employee is assigned the responsibility of maintaining the position and condition of all temporary traffic control devices throughout the duration of the Contract. Keep Engineer advised at all times of the identification and means of contacting this employee on a 24 hour basis.
- g. Keep temporary traffic control devices in the correct position, properly directed, clearly visible and clean, at all times. Ensure that all traffic control devices meet acceptable standards as outlined in American Traffic Safety Services Association (ATSSA) "Quality Guidelines for Temporary Traffic Control Devices and Features". Immediately repair, replace or clean damaged, defaced or dirty devices. Traffic control devices shall not be cleaned while installed/used. Use of warning lights on any temporary traffic control device is prohibited.

2. Work Zone Signs:

- a. Furnish, install, maintain, remove and relocate signs in accordance with the Plans and FDOT Design Standards, Index No. 600. Use signs that meet the material and process requirements of FDOT Section 994. Use Type IV sheeting for fluorescent orange work zone signs. Roll-up signs must meet the requirements of Type VI sheeting. Use Type IV or Type XI sheeting for all other work zone signs. Attach the sign to the sign support using hardware meeting the manufacturer's recommendations on the FDOT APL vendor drawings or as specified in the FDOT Design Standards.

1) Post Mounted Signs:

- a) Meet the requirements of FDOT Section 990-8.

2) Portable Signs:

- a) Use only approved systems, which includes sign stands and attachment hardware (nuts, bolts, clamps, brackets, braces, etc.), meeting the vendor requirements specified on the FDOT APL drawings.
- b) Provide Federal Highway Administration's (FHWA) accepted sign substrate for use with accepted sign stands on the National Highway System (NHS) under the provisions of the NCHRP Report 350 "Recommended Procedures for the Safety Performance Evaluation of Highway Features."

3) Barrier Mounted Signs:

- a) When post mounting criteria cannot be achieved in accordance with FDOT Design Standards, Index No. 600 and a barrier or traffic railing

exists, use temporary sign criteria provided in FDOT Design Standards, Index No. 11871.

3. Business Signs:

- a. Provide and place signs in accordance with the Plans and FDOT Design Standards, Index No. 600 series. Furnish signs having retroreflective sheeting meeting the requirements of FDOT Section 990.

4. High Intensity Flashing Lights:

- a. Furnish Type B lights in accordance with the Plans and FDOT Design Standards.

5. Warning/Channelizing Devices:

- a. Furnish warning/channelizing devices in accordance with the Plans and FDOT Design Standards.
- b. Retroreflective Collars for Traffic Cones:

- 1) Use collars for traffic cones listed on the FDOT APL that meets the requirements of FDOT Section 990. Use cone collars at night designed to properly fit the taper of the cone when installed. Place the upper 6 inch collar a uniform 3-1/2 inches distance from the top of the cone and the lower 4 inch collar a uniform 2 inches distance below the bottom of the upper 6 inch collar. Ensure that the collars are capable of being removed for temporary use or attached permanently to the cone in accordance with the manufacturer's recommendations. Provide a white sheeting having a smooth outer surface and that has the property of a retroreflector over its entire surface.

c. Barrier Wall (Temporary):

- 1) Furnish, install, maintain, remove and relocate a temporary barrier wall in accordance with the Plans. Ensure that temporary concrete barrier wall for use on roadway sections, complies with FDOT Design Standards, Index Nos. 412, 415 or 414 as specified in the Plans. Ensure that temporary concrete barrier wall for use on bridge and wall sections, complies with FDOT Design Standards, Index No 414 as specified in the Plans.
- 2) Ensure that temporary water filled barrier wall used on roadway sections meets the NCHRP Report 350 criteria or the MASH and is listed on the FDOT APL. Barriers meeting the requirements of FDOT Design Standards, Index Nos. 412, 415 or temporary water filled barriers on the FDOT APL will not be accepted as an alternate to barriers meeting the requirements of FDOT Design Standards, Index No. 414.
- 3) Trailer mounted barriers listed on the FDOT APL may be used at the option of the Contractor. Trailer mounted barriers listed on the FDOT APL must have an FHWA eligibility letter and be successfully crash tested in accordance with MASH TL-3 criteria. All trailer mounted barriers must be equipped with an FDOT APL listed truck mounted attenuator, an FDOT APL listed vehicle mounted arrow board and vehicle warning lights in accordance with this Article
- 4) Temporary Barrier Wall Meeting the Requirements of Design Standards, Index Nos. 412 and 414:

- a) Ensure the marking requirements of the respective Index are met.

5) Proprietary Precast Temporary Barrier Wall Fabricated prior to 2005:

- a) Contractor must submit a certification stating that all unmarked barrier wall units meet the requirements of the Specifications and the FDOT Design Standards. Certifications will be project specific and non-transferable

6) Proprietary Precast Temporary Barrier Wall Fabricated in 2005 or later:

- a) Ensure each wall unit has permanent clear markings, showing the manufacture date, serial number, manufacturer's name or symbol, and the FDOT APL number. Label the markings on a plate, plaque, or cast in the unit. Proprietary barrier wall fabricated prior to 2016 and marked with the "INDX 521" in lieu of the FDOT APL number will be permitted.

7) Glare Screen (Temporary):

- a) Use temporary glare screens listed on the FDOT APL that meet the requirements of FDOT Section 990. Furnish, install, maintain, remove and relocate glare screen systems in conjunction with temporary barrier wall at locations identified in the Plans.
- b) Ensure the anchorage of the glare screen to the barrier is capable of safely resisting an equivalent tensile load of 600 pounds per foot of glare screen, with a requirement to use a minimum of three fasteners per barrier section.
- c) When glare screen is utilized on temporary barrier wall, warning lights will not be required.

8) Longitudinal Channelizing Devices (LCDs):

- a) Furnish LCDs in accordance with the Plans and FDOT Design Standards. LCDs are categorized as vehicular or pedestrian and shall be interlocked. For LCDs requiring internal ballasting, an indicator that clearly identifies the proper ballast level will be required.
- b) Use alternating orange and white pattern for solid color vehicular LCDs. Vehicular LCDs may be substituted for drums, vertical panels, or barricades.

6. Temporary Crash Cushion (Redirective/Gating):

- a. Furnish, install, maintain and subsequently remove temporary crash cushions in accordance with the details and notes shown in the Plans, the FDOT Design Standards, and requirements of the pre-approved alternatives listed on the FDOT APL.
- b. Maintain the crash cushions until their authorized removal. Repair all attachment scars to permanent structures and pavements after crash cushion removal. Make necessary repairs due to defective material, work, or Contractor operations at no cost to the Department.



- c. Restore crash cushions damaged by the traveling public within 24 hours after notification as authorized by Engineer.
7. Guardrail (Temporary):
- a. Furnish guardrail (temporary) in accordance with the Plans and Design Standards. Meet the requirements of Article 536.
8. Arrow Board:
- a. Furnish arrow boards that meet the requirements of FDOT Section 990 as required by the Plans and Design Standards to advise approaching traffic of lane closures or shoulder work.
  - b. Type B arrow boards may be used on low to intermediate speed (0 mph to 50 mph) facilities or for maintenance or moving operations on any speed facility.
  - c. Type C arrow boards shall be used for all other operations on high-speed (50 mph and greater) facilities and may be substituted for Type B arrow boards on any speed facility.
9. Portable Changeable Message Sign (PCMS):
- a. Furnish PCMSs or truck mounted changeable message signs that meet the requirements of FDOT Section 990 as required by the Plans and FDOT Design Standards to supplement other temporary traffic control devices used in work zones.
10. Portable Regulatory Signs (PRS):
- a. Furnish PRSs that meet the requirements of FDOT Section 990 as required by the Plans and FDOT Design Standards.
  - b. Activate portable regulatory signs only during active work activities and deactivate when no work is being performed.
11. Radar Speed Display Unit (RSDU):
- a. Furnish RSDUs that meet the requirements of FDOT Section 990 as required by the Plans and FDOT Design Standards to inform motorists of the posted speed and their actual speed.
  - b. Activate the radar speed display unit only during active work activities and deactivate when no work is being performed.
12. Temporary Signalization and Maintenance:
- a. Provide temporary signalization and maintenance at existing, temporary, and new intersections including but not limited to the following:
    - 1) Installation of temporary poles and span wire assemblies as shown in the Plans,
    - 2) Temporary portable traffic signals as shown in the Plans,
    - 3) Adding or shifting signal heads,
    - 4) Trouble calls,
    - 5) Maintaining intersection and coordination timing and preemption devices.
  - b. Restore any loss of operation within 12 hours after notification.
  - c. Provide traffic signal equipment that meets the requirements of Article 603 of FDOT Design Standards. Engineer may approve used signal equipment if it is in acceptable condition. Replacement components for traffic signal cabinet assemblies will be provided by the maintaining agency.
13. Temporary Traffic Detection and Maintenance:
- a. Provide temporary traffic detection and maintenance at existing, temporary, and new signalized intersections. Provide temporary traffic detection equipment listed on the FDOT APL. Restore any loss of detection within 12 hours. Ensure 90% accuracy per signal phase, measured at the initial installation and after any lane shifts, by comparing sample data collected from the detection system with ground truth data collected by human observation. Collect the sample and ground truth data for a minimum of five minutes during a peak and five minutes during an off-peak period with a minimum three detections for each signal phase. Perform the test in the presence of Engineer.
14. Truck Mounted Attenuators and Trailer Mounted Attenuators:
- a. Furnish, install and maintain only those attenuators that meet the requirements of NCHRP 350 or the MASH.
  - b. Use truck mounted attenuators or trailer mounted attenuators, when called for in the FDOT Design Standards. Use attenuators listed on the FDOT APL.
  - c. When attenuators are called for, use either a truck mounted attenuator or a trailer mounted attenuator system designed and installed in accordance with the manufacturers recommendations.
  - d. Equip the attenuator cartridge with lights and reflectors in compliance with applicable Florida motor vehicle laws, including turn signals, dual tail lights, and brake lights. Ensure that lights are visible in both the raised and lowered positions if the unit is capable of being raised.
  - e. Install either alternating black with yellow or white with orange sheeting on the rear of trailer mounted attenuators and on truck mounted attenuators, in both the operating and raised position. Use Type III (work zone) or Type IV sheeting consisting of 4 or 6 inch wide stripes installed to form chevrons that point upward. All sheeting except black shall be retroreflective.
  - f. Attenuators will not be paid for separately. Include the cost of the truck with either a truck mounted attenuator or a trailer mounted attenuator under Maintenance of Traffic (General). Payment includes all costs, including furnishing, maintaining and removal when no longer required, and all materials, labor, tools, equipment and incidentals required for attenuator maintenance.
15. Temporary Raised Rumble Strip Sets:
- a. When called for in the Plans, furnish, install, maintain, remove, and reinstall temporary raised rumble strip sets.
  - b. Install the temporary raised rumble strip sets per the manufacturer's recommendations and in accordance with FDOT Design Standards, Index No. 603.

- c. The temporary raised rumble strip may be either a removable polymer striping tape or a molded engineered polymer material.

16. Automated Flagger Assistance Devices (AFAD):

- a. Furnish, install, maintain, remove and relocate AFADs in accordance with the Plans and FDOT Design Standards. Position AFADs where they are clearly visible to oncoming traffic and out of the lane of traffic. The devices may be operated either by a single flagger at one end of the traffic control zone, from a central location, or by a separate flagger near each device's location.
- b. AFADs may be either a remotely controlled Stop/Slow AFAD mounted on either a trailer or a movable cart system, or a remotely controlled Red/Yellow Lens AFAD.
- c. AFADs will not be paid for separately. AFADs may be used as a supplement or an alternate to flaggers in accordance with FDOT Index 603. Include the cost for AFADs in Maintenance of Traffic (General).

17. Temporary Lane Separator:

- a. Furnish, install, maintain, remove and relocate temporary lane separator in accordance with the Plans and FDOT Design Standards, Index No 600.
- b. Anchor the portable temporary lane separator with a removable anchor bolt. Use epoxy on bridge decks where anchoring is not allowed. Remove the epoxy from the bridge deck by hydroblasting or other method approved by Engineer.

J. Work Zone Pavement Marking.

1. Description:

- a. Furnish and install work zone pavement markings for MOT in construction areas and in close conformity with the lines and details shown in the Plans and FDOT Design Standards.
- b. Centerlines, lane lines, edge lines, stop bars and turn arrows will be required in work zones prior to opening the road to traffic.
- c. The most common types of work zone pavement markings are painted pavement markings and removable tape. Other types of work zone pavement markings may be identified in the Plans.

2. Painted Pavement Markings:

- a. General: Use painted pavement markings meeting the requirements of Article 710. Use standard waterborne paint unless otherwise identified in the Plans or approved by Engineer.

3. Removable Tape:

- a. General: Use removable tape listed on the FDOT APL and meeting the requirements of FDOT 990-4.
- b. Application: Apply removable tape with a mechanical applicator to provide pavement lines that are neat, accurate and uniform. Equip the mechanical applicator with a film cut-off device and with measuring devices that automatically and accumulatively measure the length of each line placed within an accuracy tolerance

of plus or minus 2%. Ensure removable tape adheres to the road surface. Removable tape may be placed by hand on short sections, 500 feet or less, if it is done in a neat accurate manner.

- c. Retroreflectivity: Apply white and yellow traffic stripes and markings that will attain an initial retroreflectivity of not less than 300 mcd/lx·m<sup>2</sup> for white and contrast markings and not less than 250 mcd/lx·m<sup>2</sup> for yellow markings. Black portions of contrast tapes and black masking tapes must be non-reflective and have a reflectance of less than 5 mcd/lx m<sup>2</sup>. At the end of the six month service life, the retroreflectance of white and yellow removable tape shall not be less than 150 mcd/lx·m<sup>2</sup>.
  - d. Removability: Provide removable tape capable of being removed from bituminous concrete and portland cement concrete pavement intact or in substantially large strips, either manually or by a mechanical roll-up device, at temperatures above 40°F, without the use of heat, solvents, grinding or blasting.
4. Temporary Retroreflective Pavement Markers (RPM's): Use markers listed on the FDOT APL and meeting the requirements of FDOT 990-5. Apply all markers in accordance with the FDOT Design Standards, Index Nos. 600 and 17352, prior to opening the road to traffic. Replace markers any time after installation when more than three consecutive markers fail or are missing, at no expense to the Department, in a timely manner, as directed by Engineer.

K. Method of Measurement.

1. General:

- a. Devices installed/used on the Project on any calendar day or portion thereof, within the allowable Contract Time, including time extensions which may be granted, will be paid for at the Contract unit price for the applicable pay item, except those paid for as Maintenance of Traffic (General).
- b. One or more of the following items may appear in a contract in addition to a direct payment item for Maintenance of Traffic (Lump Sum). Unless otherwise stipulated in the Contract Documents, only those items with an Awarded Unit Price will be considered for direct payment.

2. Traffic Control Officers:

- a. The County will reimburse Contractor for the services of uniformed law enforcement officers authorized to serve as traffic control officers for the purpose of controlling or directing traffic in the work zone as part of the County approved Traffic Control Plan and Maintenance of Traffic provided by Contractor pursuant to the Contract Documents.
- b. The quantity to be paid for will be the invoice unit price per hour for the actual number of officers certified to be on the project site, including any law enforcement vehicles and all other direct and indirect costs.
- c. Payment will be made at invoice cost from an appropriate dedicated allowance established by the County.

- d. Payment will be made only for those Traffic Control Officers specified in the Plans and authorized by the Engineer. The necessary invoices and documentation must be submitted to the Engineer along with the payment request.
3. Special Detours:
    - a. When a detour facility is specifically detailed in the Plans, or is otherwise described or detailed as a special item, and an item for separate payment is included in the proposal, the work of constructing, maintaining, and subsequently removing such detour facilities will be paid for separately. Traffic control devices, warning devices, barriers, signing, and pavement markings for special detours will also be paid for separately.
    - b. When the Plans show more than one detour, each detour will be paid for separately, at the Contract lump sum price for each.
    - c. Where a separate item for a specific detour facility is included in the proposal, payment will be made under special detour.
  4. Commercial Material for Driveway Maintenance:
    - a. The quantity to be paid for will be the certified volume, in cubic yards, of all materials authorized by the Engineer, acceptably placed, compacted and maintained for driveway maintenance. The volume, which is authorized to be reused, and which is acceptably salvaged, placed, compacted and maintained in other designated driveways will be included again for payment.
    - b. Arrow Board: The quantity to be paid at the contract unit price will be for the number of arrow boards certified as installed/used on the project on any calendar day or portion thereof within the contract time.
  5. Work Zone Signs:
    - a. The number of temporary post-mounted signs (temporary regulatory, warning and guide) certified as installed/used on the project will be paid for at the Contract unit price for work zone signs. When multiple signs are located on single or multiple posts, each sign panel will be paid individually. Signs greater than 20 square feet and detailed in the Plans will be paid for under Maintenance of Traffic (General).
    - b. Temporary portable signs (excluding mesh signs) and vehicular mounted signs will be included for payment under work zone signs, only if used in accordance with the FDOT Design Standards.
    - c. The number of temporary barrier mounted signs (temporary regulatory, warning and guide) certified as installed/used on the project will be paid for at the Contract unit price for barrier mounted work zone signs.
  6. Business Signs:
    - a. The number of business signs certified as installed/used on the project will be paid for at the Contract unit price for business signs.
  7. High Intensity Flashing Lights:
    - a. The number of high intensity flashing lights (Type B) certified as installed/used on the project will be paid for at the Contract unit price for high intensity flashing lights (temporary - Type B).
  8. Channelizing Devices:
    - a. The number of drums, vertical panels, pedestrian LCDs, and Type I, Type II, Type III, or direction indicator barricades, certified as installed/used on the project meeting the requirements of FDOT Design Standards, Index No. 600 and have been properly maintained will be paid for at the Contract unit prices for channelizing device.
    - b. Payment for vehicular LCDs will be paid as the length in feet installed divided by the device spacing for barricades, vertical panels, and drums and certified as installed/used on the project meeting the requirements of FDOT Design Standards, Index No. 600 and have been properly maintained will be paid for at the Contract unit price for channelizing device.
    - c. Payment will not be made for channelizing devices unsatisfactorily maintained, as determined by the Engineer.
    - d. Payment will be made for each channelizing device that is used to delineate trailer mounted devices.
    - e. Payment will be made for channelizing devices delineating portable changeable message signs during the period beginning 14 working days before Contract Time begins as authorized by the Engineer.
  9. Barrier Wall (Temporary):
    - a. The Contract unit price for barrier wall (temporary) will be full compensation for furnishing, installing, maintaining, and removing the barrier wall. When called for, the Contract unit price for barrier wall (temporary/relocate) will be full compensation for relocating the barrier. The certified quantity to be paid for will be determined by the number of sections times the nominal length of each section.
  10. Barrier Delineators:
    - a. The number of barrier delineators, installed on top of barrier wall, used on the project, meeting the requirements of FDOT Design Standards and Article 705.
  11. Lights, Temporary, Barrier Wall Mount:
    - a. The number of Type C steady burn lights, mounted on barrier wall, certified as installed/used on the project, meeting the requirements of the Design Standards and have been properly maintained will be paid for at the Contract unit price for lights temporary, barrier wall mount.
  12. Glare Screen (Temporary):
    - a. The certified quantity to be paid for will be determined by the number of sections times the nominal length of each section.
  13. Temporary Crash Cushions:
    - a. Redirective:
      - 1) The quantity to be paid for will be the number of temporary crash cushions (redirective) certified as installed/used and maintained on the project, including object marker.

b. Gating:

- 1) The quantity to be paid for will be the number of temporary crash cushions (gating) certified as installed/used and maintained on the project, including object marker.

14. Temporary Guardrail:

- a. The quantity to be paid for will be the length, in feet, of temporary guardrail constructed and certified as installed/used on the project. The length of a run of guardrail will be determined as a multiple of the nominal panel lengths.

15. Arrow Board:

- a. The quantity to be paid at the Contract unit price will be for the number of arrow boards certified as installed/used on the project on any calendar day or portion thereof within the Contract time.

16. Portable Changeable Message Sign:

- a. The quantity to be paid at the Contract unit price will be for the number of portable changeable message signs or truck mounted changeable message signs certified as installed/used on the project on any calendar day or portion thereof within the Contract time.
- b. Payment will be made for each portable changeable message sign that is used during the period beginning fourteen working days before Contract Time begins as authorized by Engineer.

17. Portable Regulatory Signs:

- a. The quantity to be paid for will be the number of portable regulatory signs certified as installed/used on the project on any calendar day or portion thereof within the Contract time, will be paid for the Contract unit price for portable regulatory sign.

18. Radar Speed Display Unit:

- a. The quantity to be paid for will be the number of radar speed display units certified as installed/used on the project on any calendar day or portion thereof within the Contract Time, will be paid for the Contract unit price for radar speed display unit.

19. Temporary Signalization and Maintenance:

- a. For existing intersections, the quantity to be paid for will be the number of signalized intersections per day for the full duration of the Contract. For temporary intersections, the quantity to be paid for will be the number of signalized intersections per day for the duration of the temporary intersection. No separate payment will be made for temporary signalization and maintenance at new intersections.

20. Temporary Traffic Detection and Maintenance:

- a. For existing intersections, the quantity to be paid for will be the number of signalized intersections per day beginning the day Contract Time begins and ending the day the permanent detection is operational and the final lane configuration is in place. For temporary and new intersections, the quantity to be paid for will be the number of signalized intersections per day beginning the day the temporary detection is functional and ending the day the permanent detection is operational

and the final lane configuration is in place for a new intersection; or, when the detection is removed for a temporary intersection.

21. Work Zone Pavement Markings:

- a. The quantities, furnished and installed, to be paid for will be the length of skip and solid pavement markings, and the area of pavement markings placed as follows:

- 1) The total transverse distance, in feet, of skip pavement marking authorized and acceptably applied. The length of actual applied line will depend on the skip ratio of the material used. Measurement will be the distance from the beginning of the first stripe to the end of the last stripe with proper deductions made for unpainted intervals as determined by plan dimensions or stations, subject to the requirements of the Contract Documents.
- 2) The net length, in feet, of solid pavement marking authorized and acceptably applied.
- 3) The number of directional arrows or pavement messages authorized and acceptably applied.
- 4) The number of temporary RPM's authorized and acceptably applied.

22. Temporary Raised Rumble Strips:

- a. The quantity to be paid for will be the number of temporary raised rumble strip sets certified as installed/used on the project on any calendar day or portion thereof within the Contract Time.
- b. The number of strips used must meet the requirements of FDOT Design Standards, Index No. 603. No adjustment will be made to the per day measurement for the number of strips or sets used, or for the number of times the sets are relocated.

23. Temporary Lane Separator:

- a. The quantity of temporary lane separator to be paid for will be plan quantity, in feet, including drainage gaps, completed and accepted.

L. Submittals.

1. Submittal Instructions:

- a. Prepare a certification of quantities for certified MOT payment items for each project in the Contract. Submit the certification of quantities to Engineer. The Department will not pay for any disputed items until Engineer approves the certification of quantities.

2. Contractor's Certification of Quantities:

- a. Request payment by submitting a certification of quantities as directed by Engineer, based on the amount of work done or completed. Ensure the certification consists of the following:
- b. Contract Number, Certification Date and the period that the certification represents.
- c. The basis for arriving at the amount of the progress certification, less payments previously made and less an amount previously retained or withheld. The basis will include a detail breakdown provided on the

certification of items of payment in accordance with 102-M. After the initial setup of the MOT items and counts, the interval for recording the counts will be made weekly on the certification sheet unless there is a change. This change will be documented on the day of occurrence. Some items may necessitate a daily interval of recording the counts.

#### M. Basis of Payment.

##### 1. Maintenance of Traffic (General):

- a. No Direct Payment Provided: When no item for direct payment of Maintenance of Traffic (Lump Sum) is provided by the Contract, the costs for performing all work and requirements specified under this Article, except as may be specifically covered for payment under other items, will be included among the various scheduled items of the Contract.
- b. Direct Payment Provided: When direct payment for Maintenance of Traffic (Lump Sum) is provided in the Contract, the quantity to be paid all work and costs specified under this Article, except as may be specifically covered for payment under other items, will be the lump sum Contract Price.

##### 2. Additional items of Direct Payment. Only those items with an Awarded Unit Price will be considered for direct payment.

###### a. Traffic Control Officers:

- 1) Price and payment will be full compensation for the services of the traffic control officers at invoice cost as specified under subarticle 102.K.2 above.

###### b. Special Detours:

- 1) Price and payment will be full compensation for providing all detour facilities shown in the Plans and all costs incurred in carrying out all requirements of this Article for general MOT within the limits of the detour, as shown in the Plans.

###### c. Commercial Materials for Driveway Maintenance:

- 1) Price and payment will be full compensation for all work and materials specified for this item, including specifically all required shaping and maintaining of driveways.

###### d. Work Zone Signs:

- 1) Price and payment will be full compensation for all work and materials for furnishing signs, supports and necessary hardware, installation, relocating, maintaining and removing signs.

###### e. Business Signs:

- 1) Price and payment will be full compensation for all materials and labor required for furnishing, installing, relocating, maintaining, and removing the signs as well as the cost of installing any logos provided by business owners.

###### f. High Intensity Warning Lights:

- 1) Price and payment will be full compensation for furnishing, installing, operating, relocating,

maintaining and removing high intensity flashing lights (Type B).

###### g. Channelizing Devices:

- 1) Prices and payment will be full compensation for furnishing, installing, relocating, maintaining and removing the channelizing devices, including the costs associated with attached warning lights as required.

###### h. Barrier Wall (Temporary):

- 1) Price and payment will be full compensation for furnishing, installing, maintaining, and removing the barrier. When called for, barrier wall (temporary) (relocate) will be full compensation for relocating the barrier.

###### i. Lights, Temporary, Barrier Wall Mount:

- 1) Price and payment will be full compensation for all work and materials for furnishing, installing and maintaining the warning lights mounted on barrier wall. Payment will not be made for lights that are improperly placed or are not working.

###### j. Barrier Delineators:

- 1) No separate payment will be made for barrier delineators installed on top of temporary barrier wall. The cost of furnishing, installing and maintaining the barrier delineators will be included in the cost of the temporary barrier wall.

###### k. Glare Screen (Temporary):

- 1) Price and payment will be full compensation for furnishing, installing, maintaining, and removing the glare screen certified as installed/used on the project. When called for, glare screen (relocate) will be full compensation for relocating the glare screen.

###### l. Temporary Crash Cushion (Redirective/Gating):

- 1) Price and payment will be full compensation for furnishing, installing, maintaining and subsequently removing such crash cushions. Payment for restoring damaged crash cushions will be the manufacturer's/distributor's invoice price for the new materials/parts plus 20% markup. The 20% markup is compensation for all necessary work including; but not limited to, labor, equipment, supplies and profit, as authorized by Engineer. Additional MOT required for the repair of the crash cushion will be paid for under the appropriate MOT pay item.

###### m. Temporary Guardrail:

- 1) Price and payment will be full compensation for furnishing all materials required for a complete installation, including end anchorage assemblies and any end connections to other structures and for installing, maintaining and removing guardrail.

###### n. Arrow Board:

- 1) Price and payment will be full compensation for furnishing, installing, operating, relocating, maintaining and removing arrow boards.

###### o. Portable Changeable Message Sign:

1) Price and payment will be full compensation for furnishing, installing, operating, relocating, maintaining and removing portable changeable message signs.

p. Portable Regulatory Signs:

- 1) Price and payment will be full compensation for furnishing, installing, relocating, maintaining and removing a completely functioning system as described in these Specifications portable regulatory signs. Price and payment will be full compensation for furnishing, installing, operating, relocating, maintaining and removing portable regulatory signs.
- 2) Payment will include all labor, materials, incidentals, repairs and any actions necessary to operate and maintain the unit at all times that work is being performed or traffic is being affected by construction and/or MOT operations.

q. Radar Speed Display Unit:

- 1) Price and payment will be made only for a completely functioning system as described in these specifications. Payment will include all labor, hardware, accessories, signs, and incidental items necessary for a complete system.
- 2) Payment will include any measurements needed to insure that the unit conforms to all specification requirements.
- 3) Payment will include all labor, materials, incidentals, repairs and any actions necessary to operate and maintain the unit at all times that work is being performed or traffic is being affected by construction and/or MOT operations. Price and payment will be full compensation for furnishing, installing, operating, relocating, maintaining and removing radar speed display unit.

r. Temporary Signalization and Maintenance:

- 1) Price and payment will constitute full compensation for furnishing, installing, operating, maintaining and removing temporary traffic control signals including all equipment and components necessary to provide an operable traffic signal. Payment will be withheld for each day at each intersection where the temporary signalization is not operational within 12 hours after notification.

s. Temporary Traffic Detection and Maintenance:

- 1) Price and payment will constitute full compensation for furnishing, installing, operating, maintaining and removing temporary traffic detection including all equipment and components necessary to provide an acceptable signalized intersection. Take ownership of all equipment and components. Payment will be withheld for each day at each intersection where the temporary detection is not operational within 12 hours after notification.

t. Temporary Raised Rumble Strips:

- 1) Price and payment will be full compensation for all work and materials described in this Article, including all cleaning and preparing of surfaces,

disposal of all debris, furnishing of all materials, application, curing, removal, reinstalling and protection of all items, protection of traffic, furnishing of all tools, machines and equipment, and all incidentals necessary to complete the work.

u. Work Zone Pavement Markings:

- 1) Price and payment will be full compensation for all work specified including, all cleaning and preparing of surfaces, furnishing of all materials, application, curing and protection of all items, protection of traffic, furnishing of all tools, machines and equipment, and all incidentals necessary to complete the work. Final payment will be withheld until all deficiencies are corrected.
- 2) Removable tape may be substituted for work zone paint at no additional cost to the Department.
- 3) Payment for temporary RPMs used to supplement line markings will be paid for under temporary retroreflective pavement markers. Install these markers as detailed in the Design Standards.

v. Temporary Lane Separator:

- 1) Price and payment will be full compensation for all work specified in this Article.

3. Payment Items: Payment will be made under:

Item No.	Description	Unit
102-1A	Maintenance of Traffic	LS

**104 PREVENTION, CONTROL, AND ABATEMENT OF EROSION AND WATER POLLUTION (REV. 01-09-12)**

A. Description.

1. Provide erosion control measures on the Project and in areas outside the right-of-way where work is accomplished in conjunction with the Project, so as to prevent pollution of water, detrimental effects to public or private property adjacent to the Project right-of-way, and damage to work on the Project.
2. Construct and maintain temporary erosion control features and, as required, construct and maintain permanent erosion control features as shown in the Plans or as may be directed by Engineer.

B. General.

1. Coordinate the installation of temporary erosion control features with the construction of the permanent erosion control features to the extent necessary to ensure economical, effective, and continuous control of erosion and water pollution throughout the life of the Contract.
2. Maintain, at the work site, copies of all documents referenced by this Specification including: the Departmental Stormwater Pollution Prevention Plan (if provided); the approved contractor Erosion Control Plan; and applicable inspection reports, permits and certifications. Document compliance with all

requirements pertaining to the aforementioned documents and this Specification.

3. Engineer may direct, when warranted by unforeseen conditions, the use of control features or methods other than those included in the original Contract. In such event, the Department will pay for this additional work as unforeseeable work.
- C. Control of Contractor's Operations Which May Result in Water Pollution.
1. Prevent pollution of streams, canals, lakes, reservoirs, and other water impoundments with fuels, oils, bitumens, calcium chloride, or other harmful materials.
  2. Conduct and schedule operations to avoid or otherwise minimize pollution or siltation of such water impoundments, and to avoid interference with movement of migratory fish. Do not dump any residue from dust collectors or washers into any water body.
  3. Restrict construction operations in rivers, streams, lakes, tidal waters, reservoirs, canals, and other water impoundments to those areas where it is necessary to perform filling or excavation to accomplish the work shown in the Plans and to those areas which must be entered to construct temporary or permanent structures. As soon as conditions permit, promptly clear rivers, streams, and impoundments of all obstructions placed therein or caused by construction operations.
  4. Do not frequently ford live streams with construction equipment. Wherever an appreciable number of stream crossings are necessary at any one location, use a temporary bridge or other structure.
  5. Except as necessary and authorized for Project construction, do not deposit excavated material in rivers, streams, canals, or impoundments, or in a position close enough thereto, to be washed away by high water or runoff.
  6. Where pumps are authorized for use in removing highly turbid waters from enclosed construction areas such as cofferdams or forms, treat the water by one or more of the following methods prior to discharge into State waters:
    - a. Pumping into grassed swales or appropriate vegetated areas or sediment basins.
    - b. Confined by an appropriate enclosure such as turbidity barriers when other methods are not considered appropriate.
  7. Do not disturb lands or waters outside the limits of construction as staked, except as authorized by Engineer.
  8. Obtain Engineer's approval for the location of, and method of operation in, borrow pits, material pits, and disposal areas furnished for waste material from the project (other than commercially operated sources) such that erosion during and after completion of the work will not result in probability of detrimental siltation or water pollution.
- D. Materials for Temporary Erosion Control.

1. Engineer will not require testing of materials used in construction of temporary erosion control features other than as provided for geotextile fabric in FDOT 985-3 unless such material is to be incorporated into the completed Project.
2. When no testing is required, Engineer will base acceptance on visual inspection.
3. Contractor may use new or used materials, subject to Engineer's approval, for the construction of temporary silt fence, staked turbidity barriers, and floating turbidity barrier not to be incorporated into the completed Project.

E. Erosion Control Plan.

1. Prepare the Erosion Control Plan (ECP) in a format acceptable to the Department and in accordance with the planned sequence of operations.
2. At the Preconstruction Conference, submit to the Department an ECP that:
  - a. Meets the requirements or conditions of all permits authorizing construction of the Project. Where no permits are required or the approved permits do not contain conditions that specifically addresses erosion and water pollution, the requirements of the ECP will be governed by the Contract Documents and all applicable laws, rules, or regulations.
  - b. Accompanies the Department's Stormwater Pollution Prevention Plan (SWPPP) when a SWPPP is provided for the Project.
  - c. Includes and describes for each phase of construction operations or activities the following:
    - 1) Locations of all erosion control devices
    - 2) Types of all erosion control devices
    - 3) Estimated time erosion control devices will be in operation
    - 4) Monitoring schedules for maintenance of erosion control devices
    - 5) Methods of maintaining erosion control devices
    - 6) Containment or removal methods for pollutants or hazardous wastes
    - 7) The name and telephone number of the person responsible for monitoring and maintaining the erosion control devices.
  - d. Includes procedures to control off-site tracking of soil by vehicles and construction equipment and a procedure for cleanup and reporting of non-stormwater discharges.
  - e. Describes all phases of operations, the prevention, control, and abatement of erosion and water pollution items or activities necessary for the Project, to include:
    - 1) Types and locations of all erosion control devices
    - 2) Estimated time erosion control devices will be in operation
    - 3) Monitoring schedules for maintenance of erosion control devices

- 4) Methods for maintaining erosion control devices
  - 5) Containment or removal methods for pollution or hazardous wastes
  - 6) Name and telephone number of the person responsible for monitoring and maintaining the erosion control devices.
3. Contractor must obtain Engineer's written approval of the ECP prior to commencing any construction activities.
  4. For project requiring a Florida Department of Environmental Protection (FDEP) Generic Permit for Stormwater Discharge from Large and Small Construction Activities (Generic Permit):
    - a. Failure to sign any documents or certification statements required by the FDEP Generic Permit will be considered a default of the Contract.
    - b. Any soil disturbing activities performed without the required signed documents or certifications statements may be considered a violation of the FDEP Generic Permit.

#### F. Construction Requirements.

##### 1. Limitation of Exposure of Erodible Earth:

- a. Engineer may limit the surface areas of unprotected erodible earth exposed by the construction operation and may direct Contractor to provide erosion or pollution control measures to prevent contamination of any river, stream, lake, tidal waters, reservoir, canal, or other water impoundments or to prevent detrimental effects on property outside the Project right-of-way or damage to the Project.
- b. Limit the area in which excavation and filling operations are being performed so that it does not exceed the capacity to keep the finish grading, turf, sod, and other such permanent erosion control measures current in accordance with the accepted schedule.
- c. Do not allow the surface area of erodible earth that clearing and grubbing operations or excavation and filling operations expose to exceed 750,000 square feet without specific prior approval by Engineer. This limitation applies separately to clearing and grubbing operations and excavation and filling operations.
- d. Engineer may increase or decrease the amount of surface area the Contractor may expose at any one time.

##### 2. Incorporation of Erosion and Sediment Control Features:

- a. Incorporate permanent erosion control features into the project at the earliest practical time. Use temporary erosion and sediment control features found in the State of Florida Erosion and Sediment Control Designer and Reviewer Manual (E&SC Manual) to correct conditions that develop during construction which were not foreseen at the time of design, to control erosion and sediment prior to the time it is practical to construct permanent control features, or to provide immediate temporary control of erosion and sediment that develops during normal construction operations, which are not associated with permanent erosion control features on the project. An electronic version of the

E&SC Manual can be found at the following URL: <http://www.dot.state.fl.us/specificationsoffice/Implemented/URLinSpecs/Files/FLerosionSedimentManual060709.pdf>

- b. Install all sediment control devices in a timely manner to ensure the control of sediment and the protection of lakes, streams, gulf or ocean waters, or any wetlands associated therewith and to any adjacent property outside the right-of-way as required.
- c. At sites where exposure to such sensitive areas is prevalent, complete the installation of any sediment control device prior to the commencement of any earthwork.
- d. After installation of sediment control devices, repair portions of any devices damaged at no expense to the Department. Engineer may authorize temporary erosion and sediment control features when finished soil layer is specified in the Contract and the limited availability of that material from the grading operations will prevent scheduled progress of the work or damage the permanent erosion control features.

##### 3. Scheduling of Successive Operations:

- a. Schedule operations such that the area of unprotected erodible earth exposed at any one time is not larger than the minimum area necessary for efficient construction operations, and the duration of exposure of uncompleted construction to the elements is as short as practicable.
- b. Schedule and perform clearing and grubbing so that grading operations can follow immediately thereafter. Schedule and perform grading operations so that permanent erosion control features can follow immediately thereafter if conditions on the project permit.

##### 4. Details for Temporary Erosion and Sediment Control Features:

- a. General: Use temporary erosion, sediment and water pollution control features found in the E&SC Manual. These features consist of, but are not limited to, temporary turf, rolled erosion control products, sediment containment systems, runoff control structures, sediment barriers, inlet protection systems, silt fences, and turbidity barriers. For design details for some of these items, refer to the Plans, the FDOT Design Standards and E&SC Manual.
- b. Temporary Sod: Engineer may designate certain areas of sod constructed in accordance with the Specifications as temporary erosion control features. For areas not defined as sod, constructing temporary turf by seeding only is not an option for temporary erosion control under this Article. Engineer may waive the turf establishment requirements of the Specifications for areas with temporary sod that will not be a part of the permanent construction. The work of placing temporary sod, approved as a temporary erosion control feature where directed by Engineer and in accordance with these Specifications, will be paid for as unforeseeable work.
- c. Runoff Control Structures: Construct runoff control structures in accordance with the details shown in the Plans, the E&SC Manual, or as may be approved as suitable to adequately perform the intended function.



- d. Sediment Containment Systems: Construct sediment containment systems in accordance with the details shown in the Plans, the E&SC Manual, or as may be approved as suitable to adequately perform the intended function. Clean out sediment containment systems as necessary in accordance with the Plans or as directed.
- e. Sediment Barriers: Provide and install sediment barriers according to details shown in the Plans, as directed by Engineer, or as shown in the E&SC Manual to protect against downstream accumulation of sediment. Sediment Barriers include, but are not limited to synthetic bales, silt fence, fiber logs and geosynthetic barriers. Reusable barriers that have had sediment deposits removed may be reinstalled on the Project as approved by Engineer.
- f. Silt Fence:
  - 1) General: Furnish, install, maintain, and remove silt fences, in accordance with the manufacturer's directions, these Specifications, the details as shown on the Plans, the FDOT Design Standards, and the E&SC Manual.
  - 2) Materials and Installation: Use a geotextile fabric made from woven or nonwoven fabric, meeting the physical requirements of FDOT Section 985 according to those applications for erosion control. Choose the type and size of posts, wire mesh reinforcement (if required), and method of installation. Do not use products which have a separate layer of plastic mesh or netting. Provide a durable and effective silt fence that controls sediment comparable to the FDOT Design Standards and the E&SC Manual. Erect silt fence at upland locations, across ditch lines and at temporary locations shown on the plans or approved by Engineer where continuous construction activities change the natural contour and drainage runoff. Do not attach silt fence to existing trees unless approved by Engineer.
  - 3) Inspection and Maintenance: Inspect all silt fences immediately after each rainfall and at least daily during prolonged rainfall. Immediately correct any deficiencies. In addition, make a daily review of the location of silt fences in areas where construction activities have changed the natural contour and drainage runoff to ensure that the silt fences are properly located for effectiveness. Where deficiencies exist, install additional silt fences as directed by Engineer. Remove sediment deposits when the deposit reaches approximately 1/2 of the volume capacity of the silt fence or as directed by Engineer. Dress any sediment deposits remaining in place after the silt fence is no longer required to conform with the finished grade, and prepare them in accordance with the Contract Documents and as directed by Engineer.
- g. Floating Turbidity Barriers and Staked Turbidity Barriers:
  - 1) Install, maintain, and remove turbidity barriers to contain turbidity that may occur as the result of dredging, filling, or other construction activities which may cause turbidity to occur in the waters of the State. Contractor may need to deploy turbidity barriers around isolated areas of concern such as seagrass beds, coral communities, etc. both within as well as outside the right-of-way limits. Engineer will identify such areas. Place the barriers prior to the commencement of any work that could impact the area of concern. Install the barriers in accordance with the details shown in the Plans or as approved by Engineer. Ensure that the type barrier used and the deployment and maintenance of the barrier will minimize dispersion of turbid waters from the construction site. Engineer may approve alternate methods or materials.
- 2) Operate turbidity barriers in such a manner to avoid or minimize the degradation of the water quality of the surrounding waters and minimize damage to areas where floating barriers installed.
- h. Inlet Protection System: Furnish and install inlet protection systems as shown in the Plans, FDOT Design Standards and the E&SC Manual.
- i. Rolled Erosion Control Products (RECPs):
  - 1) General: Install RECPs in locations where temporary protection from erosion is needed. Two situations occur that require artificial coverings each having differing material requirements.
    - a) Temporary pauses in construction: Use RECPs composed of natural or synthetic fiber mats, plastic sheeting, or netting as protection against erosion, when directed by Engineer, during temporary pauses in construction caused by inclement weather or other circumstances. Remove the material when construction resumes.
    - b) Facilitating plant growth: Use RECPs as erosion control blankets, at locations shown in the plans, to facilitate plant growth while permanent grassing is being established. For the purpose described, use non-toxic, biodegradable, natural or synthetic woven fiber mats. Install erosion control blankets capable of sustaining a maximum design velocity of 6.5 ft/sec as determined from tests performed by Utah State University, Texas Transportation Institute or an independent testing laboratory approved by the Department. Furnish to Engineer, two certified copies of manufacturers test reports showing that the erosion control blankets meet the requirements of this Specification. Certification must be attested, by a person having legal authority to bind the manufacturing company. Also, furnish two 4 by 8 inch samples for product identification. The manufacturers test records shall be made available to the Department upon request. Leave the material in place, as installed, to biodegrade.
- 5. Removal of Temporary Erosion Control Features: In general, remove or incorporate into the soil any temporary erosion control features existing at the time of construction of the permanent erosion control features in an area of the Project in such a manner that no detrimental effect will result. Engineer may direct that temporary features be left in place.

G. Maintenance of Erosion and Sediment Control Features.

1. General: Provide routine maintenance of permanent and temporary erosion and sediment control features, at no expense to the Department, until the Project is complete and accepted. If reconstruction of such erosion and sediment control features is necessary due to Contractor's negligence or carelessness or, in the case of temporary erosion and sediment control features, failure by the Contractor to install permanent erosion control features as scheduled, Contractor must replace such erosion control features at no expense to the Department. If reconstruction of permanent or temporary erosion and sediment control features is necessary due to factors beyond the control of Contractor, the Department will pay for replacement under the appropriate Contract pay item or items.
2. Inspect all erosion and sediment control features at least once every seven calendar days and within 24 hours of the end of a storm of 0.50 inches or greater. Maintain all erosion control features as required in the SWPPP, Contractor's ECP, the E&SC Manual, and as specified in the State of Florida Department of Environmental Protection Generic Permit for Stormwater Discharge from Large and Small Construction Activities.

H. Protection During Suspension of Contract Time.

1. If it is necessary to suspend the construction operations for any appreciable length of time, shape the top of the earthwork in such a manner to permit runoff of rainwater, and construct earth berms along the top edges of embankments to intercept runoff water. Provide temporary slope drains to carry runoff from cuts and embankments that are in the vicinity of rivers, streams, canals, lakes, and impoundments. Locate slope drains at intervals of approximately 500 feet, and stabilize them by paving or by covering with waterproof materials. Should such preventive measures fail, immediately take such other action as necessary to effectively prevent erosion and siltation. Engineer may direct Contractor to perform, during such suspensions of operations, any other erosion and sediment control work deemed necessary.

I. Method of Measurement.

1. Direct Payment Provided:
  - a. When separate items for temporary erosion control features are included in the Contract and have awarded Contract prices, the quantities to be paid for will be the:
    - 1) Area, in square yards, of Rolled Erosion Control Products.
    - 2) Length, in feet, of Runoff Control Structures, measured along the surface of the work constructed.
    - 3) Number of Sediment Containment Systems constructed and accepted.
    - 4) Number of Sediment Containment System Cleanouts accomplished and accepted.
    - 5) Length, in feet, of Sediment Barriers.

6) Length, in feet, of Floating Turbidity Barrier.

7) Length, in feet, of Staked Turbidity Barrier.

8) Number of inlet protection systems.

- b. Upon acceptance by the Engineer, the quantity of floating turbidity barriers, sediment barriers, staked turbidity barriers, and inlet protection devices will be paid for regardless of whether materials are new, used, or relocated from a previous approved installation on the Project.

2. No Direct Payment Provided: Unless otherwise specified, when no item for direct payment of temporary erosion control features is provided by the Contract, the costs for performing all work and meeting the requirements of this Article will be included among the various scheduled items of the Contract.

J. Basis of Payment.

1. Prices and payments will be full compensation for all work specified in this Article, including construction and routine maintenance of temporary erosion control features.
2. Any additional costs resulting from compliance with the requirements of this Article, other than construction, routine maintenance, and removal of temporary erosion control features, will be included in the Contract unit prices for the item or items to which such costs are related.
3. Separate payment will not be made for the cost of constructing temporary earth berms along the edges of the roadways to prevent erosion during grading and subsequent operations. Contractor must include these costs in the Contract prices for earthwork items.
4. Additional temporary erosion control features constructed as directed by Engineer will be paid for as unforeseeable work.
5. In case of repeated failure on the part of Contractor to control erosion, pollution, or siltation, Engineer reserves the right to employ outside assistance or to use the Department's own forces to provide the necessary corrective measures. Any such costs incurred, including engineering costs, will be charged to Contractor and appropriate deductions made from the monthly progress estimate.

6. Payment will be made under:

Item No.	Description	Unit
Item No. 104-11A	Floating Turbidity Barrier	LF

**105 CONTRACTOR QUALITY CONTROL GENERAL REQUIREMENTS (REV. 08-23-12)**

A. General.

1. Submit to Engineer a meeting the requirements stipulated in this Article and that addresses the transportation, storage, placement, sampling, inspection of Contract materials and related construction operations; and to ensure that all work and material incorporated into

- the Project meet the requirements of the Contract Documents.
2. Comply with all personnel qualification requirements stipulated in this Article and elsewhere in the Contract Documents.
- B. Guidelines for Development of the CQCP
1. Use the following guidelines for developing the CQCP and include other additional items as necessary.
    - a. General. Provide detailed policies, methods and procedures to ensure the specified quality of all applicable materials and related production and field operations.
    - b. Process control testing. List the material to be tested by pay item, tests to be conducted, the location of sampling, and the frequency of testing.
    - c. Inspection/control procedures. Address each of the following subjects in each phase of construction:
      - 1) Preparatory phase.
        - a) Review all Contract requirements.
        - b) Ensure compliance of component material to the Contract requirements.
        - c) Coordinate all submittals including certifications.
        - d) Ensure capability of equipment and personnel to comply with the Contract requirements.
        - e) Ensure preliminary testing is accomplished.
        - f) Coordinate surveying and staking of the work.
      - 2) Start-up phase.
        - a) Review the Contract requirements with personnel performing the work.
        - b) Inspect start-up of work.
        - c) Establish standards of workmanship.
        - d) Provide training as necessary.
        - e) Establish detailed testing schedule based on the production schedule.
      - 3) Production phase.
        - a) Conduct intermittent or continuous inspection during construction to identify and correct deficiencies.
        - b) Inspect completed work before requesting Engineer inspection acceptance.
        - c) Provide feedback and system changes to prevent repeated deficiencies.
    - d. Description of records. List the records to be maintained.
    - e. Personnel qualifications.
      - 1) Identify the primary contact that will communicate with the Department. Identify roles and responsibilities of the personnel involved in the Quality Control (QC) process. Document the name, authority, relevant experience, and qualifications of person with overall responsibility for the inspection system.
  - 2) Document the names, authority, and relevant experience of all personnel directly responsible for inspection and testing.
  - 3) Submit the Training Identification Numbers (TINs) or any other information which will be traceable to the certification agency's training location and dates for all technicians performing sampling, testing and inspection for both field and laboratory tests. Provide the names of the Florida Department of Transportation's Construction Training and Qualification Program (CTQP) certifications and other pertinent certifications held and the expiration dates for each certification for each technician. Include employed and subcontracted technicians.
- f. Subcontractors.
- 1) Include the work of all subcontractors.
  - 2) If a subcontractor is to perform work subject to the requirements of this Article, detail how that subcontractor will interface with Contractor's and other subcontractor's organizations.
- g. Raw Materials:
- 1) Source: Identify the sources of raw materials. Provide locations and plant or mine numbers when applicable. Include the mailing address, physical address including county of the plant, telephone and fax numbers, E-mail address, primary contact at the plant, responsible person in charge, facility number provided by the FDOT, Owner information and Vendor Number and other information as required.
  - 2) Certification: Describe methods of verifying compliance of certification with the Specifications.
  - 3) Disposition of Failing Materials: Describe the system for controlling non-conforming materials, including procedures for identification, isolation and disposition.
  - 4) Storage Facilities for Raw Materials: Describe measures and methods, including bedding details, for preventing segregation, contamination and degradation.
  - 5) Describe methods of identifying individual materials. Where applicable, submit a site plan showing the locations of various materials.
- h. Production Equipment: Describe calibration frequencies, maintenance schedule and procedures for production equipment.
- i. Other Requirements:
- 1) Copy of Certification: Attach certifications issued by the plant/Contractor for the products approved by the FDOT that will be used in the Project.
  - 2) Statement of Compliance: Include a statement of compliance with all quality requirements set forth by the Department in the Contract Documents.
  - 3) Information on Producers with Accepted FDOT Quality Control Programs: All producers of materials listed herein in Subarticle 105-G.1 must have FDOT accepted QC Programs and be listed

on the FDOT's List of Producers with Accepted QC Programs. Identify the Producers of materials for the Project and include the FDOT's Facility Id number as part of the identification.

- 4) Describing Documentation Procedure: Identify location of document storage to enable Department review. Include QC charts, qualification/accreditation records, inspection reports, and other pertinent/supporting documents for an approved CQCP.

j. Final Manufactured Product - Plant Operations: Describe inspection schedule and methods for identifying defects and non-compliance with the specifications. Describe corrective actions and methods to resolve them.

- 1) Storage: When storage of the produced materials is required and it is not defined in the Contract Documents, describe the methods and duration for storage. Include measures and methods for preventing segregation, contamination and degradation during storage.
- 2) Disposition of Failing Materials: When not described in the specifications, describe the methods and measures for identifying and controlling the failing materials. Include preventive and corrective measures. Describe disposition of failing materials.

k. Final Manufactured Product - Field Operations:

- 1) Transportation: Describe the method of delivery from the point of production/storage to the point of placement.
- 2) Storage: When storage of the produced materials is required and it is not defined in the Contract Documents, describe the methods and duration for storage. Include measures and methods for preventing segregation, contamination and degradation during storage.
- 3) Placement: Describe the methods and identify the type of equipment used in incorporation of the materials into the project.
- 4) Disposition of Failing Materials: When not described in the specifications, describe the methods and measures for identifying and controlling the failing materials. Include preventive and corrective measures. Describe disposition of failing materials.

C. Quality Control Plan Submittal.

1. Submit the CQCP to Engineer for approval within 21 days after the Contract Award or at the Preconstruction Conference, whichever is sooner. Do not incorporate materials into the Project or begin any work subject to the CQCP prior to Engineer's acceptance of the CQCP.
2. Modifications or additions may be required to any part of the CQCP that is not adequately covered. Acceptance of the CQCP will be based on the inclusion of the required information. Acceptance does not imply any warranty by the County that the CQCP will result in consistent contract compliance. It remains the responsibility of Contractor to demonstrate such compliance.

3. If at any time Contractor is not in compliance with the approved CQCP, or a part thereof, affected portions of the CQCP will be disapproved. Cease work in the affected operation(s) and submit a revision to Engineer. If the CQCP, or a part thereof, must be revised, submit the revision to Engineer. Engineer will review the revision and respond within seven calendar days of receipt.
4. Continue to work on operations that are still in compliance with the approved sections of the CQCP.
5. As work progresses, submit to Engineer for acceptance supplementary documentation to the CQCP whenever quality control or quality control personnel changes are necessary.

D. Quality Control Documentation.

1. Maintain complete testing and inspection records by pay item number and make them accessible to Engineer. When or where required, submit the record and certification within one working day of the work being performed. If the record is incomplete, in error, or otherwise misleading, a copy of the record will be returned with corrections noted. When chronic errors or omissions occur, correct the procedures by which the records are produced.
2. Submission of Materials Certification and Reporting Test Results: Provide certifications prior to placement of materials. Report test results at completion of the test and meet the requirements of the applicable Specifications.
3. Worksheets: Make available to the Department, when requested, worksheets used for collecting test information. Ensure the worksheets at a minimum contain the following:
  - a. Project Identification Number,
  - b. Time and Date,
  - c. Laboratory Identification and Name,
  - d. Training Identification Numbers (TIN) and initials,
  - e. Record details as specified within the test method.
4. Inspections to Assure Compliance with Acceptance Criteria.
  - a. General: The Department is not obligated to make an inspection of materials at the source of supply, manufacture, or fabrication.
  - b. Quality Control Inspection: Provide all necessary inspection to assure effective Quality Control of the operations related to materials acceptance. This includes but is not limited to sampling and testing, production, storage, delivery, construction and placement. Ensure that the equipment used in the production and testing of the materials provides accurate and precise measurements in accordance with the applicable Specifications. Maintain a record of all inspections, including but not limited to, date of inspection, results of inspection, and any subsequent corrective actions taken. Make available to the Department the inspection records, when requested.
  - c. Notification of Placing Order:
    - 1) Order materials sufficiently in advance of their incorporation in the work to allow time for sampling,

testing and inspection. Notify Engineer, prior to placing orders for materials.

- 2) Submit to Engineer a fabrication schedule for all items requiring commercial inspection, before or at the preconstruction meeting. These items include, but are not limited to steel bridge components, overhead cantilevered sign supports with cantilevered arms exceeding 41 feet, moveable bridge components or any other item identified as an item requiring commercial inspection in the Contract Documents.
- 3) Notify Engineer at least 30 days before beginning any production and include a production schedule.

#### E. Contractor Certification of Compliance.

1. Provide Engineer with a notarized monthly certification of compliance with the requirements of this Article, to accompany each progress estimate, on a form acceptable by Engineer. The Department may not authorize payment of any progress estimate not accompanied by an executed certification document.
2. Final payment will not be made until a final notarized certification summarizing all QC exceptions has been submitted.

#### F. Personnel Qualifications.

##### 1. General:

- a. Provide qualified personnel for sampling, testing and inspection of materials and construction activities. Ensure that qualifications are maintained during the course of sampling, testing and inspection.
- b. Construction operations that require a qualified technician must not begin until Engineer verifies that the technician is on the FDOT CTQP list of qualified technicians.

##### 2. QC Manager:

- a. Designate a QC Manager who has full authority to act as Contractor's agent to institute any and all actions necessary for the successful implementation of the CQCP. The QC Manager must speak and understand English. The QC Manager must be on-site at the Project on a daily basis or always available upon four hours notice to administer the CQCP. This includes administering, implementing, monitoring, and as necessary, adjusting the processes to ensure compliance with the Contract Documents. Ensure that the QC Manager is qualified as such through the FDOT CTQP.
- b. Under the direction of the QC Manager, and using standard forms approved by Engineer, summarize the daily QC activities including testing and material sampling. Since erasures are strictly prohibited on all reports and forms, use blue or colored ink. Do not use black ink. If manual corrections to original data are necessary, strike through, correct, and date the entry, including the initials of the person making the correction. Make copies of the completed forms available for the Department to review daily unless otherwise required in the specifications. Maintain all QC

related reports and documentation for a period of three years from final acceptance of the Project. Make copies available for review by the Department upon request.

##### 3. Worksite Traffic Supervisor:

- a. Provide a Worksite Traffic Supervisor who is responsible for initiating, installing, and maintaining all traffic control devices as described in Article 102 (Maintenance of Traffic) and in the Contract Documents. Ensure that the Worksite Traffic Supervisor is certified in the advanced training category by a FDOT approved training Provider. Approved Providers will be posted on the FDOT's website at the following URL address:

1) <http://www.dot.state.fl.us/rddesign/MOT/MOT.shtm>

- b. Use approved alternate Worksite Traffic Supervisors when necessary.

4. Flagger: Provide trained flaggers to direct traffic where one-way operation in a single lane is in effect and in other situations as required. The Worksite Traffic Supervisor or others as approved by the Department will provide training for flaggers.

##### 5. Earthwork Quality Control Personnel:

- a. Earthwork Level I: Ensure the technician who samples soil and earthwork materials from the roadway project, takes earthwork moisture and density readings, and records those data in the Density Log Book holds a CTQP Earthwork Construction Inspection Level I qualification.
- b. Earthwork Level II: Ensure the technician responsible for determining the disposition of soil and earthwork materials on the roadway, and for interpreting and meeting Contract Document requirements holds a CTQP Earthwork Construction Inspection Level II qualification.

##### 6. Asphalt Quality Control Personnel:

- a. Plant Technicians: For asphalt plant operations, provide a QC technician, qualified as a CTQP Asphalt Plant Level II technician, available at the asphalt plant at all times when producing mix for the Department. Perform all asphalt plant related testing with a CTQP Asphalt Plant Level I technician. As an exception, measurements of temperature may be performed by someone under the supervision of a CTQP Plant Level II technician.
- b. Paving Technicians: For paving operations (with the exception of miscellaneous or temporary asphalt), keep a qualified CTQP Asphalt Paving Level II technician on the roadway at all times when placing asphalt mix for the Department, and perform all testing with a CTQP Asphalt Paving Level I technician. As an exception, measurements of cross-slope, temperature, and yield (spread rate) can be performed by someone under the supervision of a CTQP Paving Level II technician at the roadway.
- c. Mix Designer: Ensure all mix designs are developed by individuals who are CTQP qualified as an Asphalt Hot Mix Designer.
- d. Documentation: Document all QC procedures, inspection, and all test results and make them available

for review by Engineer throughout the life of the Contract. Identify in the asphalt producer's Quality Control Plan the Quality Control Manager(s) and/or Asphalt Plant Level II technician(s) responsible for the decision to resume production after a quality control failure.

7. Concrete QC Personnel:

- a. Concrete Field Technician - Level I: Ensure technicians performing plastic property testing on concrete for materials acceptance are qualified CTQP Concrete Field Technicians Level I. Plastic property testing will include but not be limited to slump, temperature, air content, water-to-cementitious materials ratio calculation, and making and curing concrete cylinders. Duties will include initial sampling and testing to confirm specification compliance prior to beginning concrete placements, ensuring timely placement of initial cure and providing for the transport of compressive strength samples to the designated laboratories.
- b. Concrete Field Inspector - Level II: Ensure field inspectors responsible for the quality of concrete being placed on major bridge projects are qualified CTQP Concrete Field Inspectors Level II. A Level II Inspector must be present on the jobsite during all concrete placements. Prior to the placement of concrete, the inspector will inspect the element to be cast to ensure compliance with Contract Documents. A Level II Inspector's duties may include ensuring that concrete testing, inspection, and curing in the field are performed in accordance with the Contract Documents. The QC Inspector will inform the Verification Inspector of anticipated concrete placements and LOT sizes.
- c. Concrete Laboratory Technician:
  - 1) Concrete Laboratory Technician - Level I: Ensure technicians testing cylinders and recording concrete strength for material acceptance are qualified CTQP Concrete Laboratory Technicians Level I. Duties include final curing, compressive strength testing, and the recording/reporting of all test data.
  - 2) Concrete Laboratory Technician – Level II: Ensure that laboratories providing hardened property test results to the Department are under the supervision of a CTQP Concrete Laboratory Technician - Level II. This person is responsible to ensure that the tests are performed in accordance with Standard Test Methods, project specifications and other contract documents.

8. Supervisory Personnel – Post-Tensioned and Movable Bridge Structures:

- a. General: Provide supervisory personnel meeting the qualification requirements only for the post-tensioned and movable bridge types detailed in this Article. Submit qualifications to Engineer at the pre-construction conference. Do not begin construction until the qualifications of supervisory personnel have been approved by Engineer.
- b. Proof of License or Certification:
  - 1) Submit a copy of the Professional Engineer license current and in force issued by the state in which registration is held. The license must be for the field

of engineering that the construction work involves such as Civil, Electrical or Mechanical. Under certain circumstances Florida registration may be required.

- 2) Submit a copy of the license issued by the State of Florida for tradesmen that require a license indicating that the license is in force and is current. Submit a copy of the certification issued by the Instrumentation, Systems and Automation Society of America for each Certified Control Systems Technician.
- c. Experience Record: Submit the following information for supervisory personnel to substantiate their experience record. The supervisor (project engineer, superintendent/manager or foreman) seeking approval must provide a notarized certification statement attesting to the completeness and accuracy of the information submitted. Provide the following experience information for each individual seeking approval as a supervisor:
  - 1) Project owner's name and telephone number of an owner's representative, project identification number, state, city, county, highway number and feature intersected.
  - 2) Provide a detailed description of each bridge construction experience, and the level of supervisory authority during that experience. Report the duration in weeks, as well as begin and end dates, for each experience period.
  - 3) Provide the name, address and telephone number of an individual that can verify that the experience being reported is accurate. This individual should have been an immediate supervisor unless the supervisor cannot be contacted in which case another individual with direct knowledge of the experience is acceptable.
- d. Concrete Post-Tensioned Segmental Box Girder Construction: Ensure the individuals filling the following positions meet the minimum requirements as follows:
  - 1) Project Engineer-New Construction: Ensure the Project Engineer is a registered Professional Engineer with five years of bridge construction experience. Ensure a minimum of three years of experience is in Segmental Box Girder Construction Engineering and includes a minimum of one year in segmental casting yard operations and related surveying, one year in segment erection and related surveying, including post-tensioning and grouting of longitudinal tendons and a minimum of one year as the Project Engineer in responsible charge of Segmental Box Girder Construction Engineering. Ensure this individual is present at the site of construction, at all times while segmental box girder construction or segment erection is in progress.
  - 2) Project Engineer-Repair and Rehabilitation: Ensure the Project Engineer is a registered Professional Engineer with five years of bridge construction experience. Ensure a minimum of three years of experience is in Segmental Box Girder Construction Engineering and includes one year of post-tensioning and grouting of longitudinal tendons and

a minimum of one year as the Project Engineer in responsible charge of Segmental Box Girder rehabilitation engineering or Segmental Box Girder new construction engineering.

- 3) Project Superintendent/Manager - New Construction:
  - a) Ensure the Project Superintendent/Manager has a minimum of ten years of bridge construction experience or is a registered Professional Engineer with five years of bridge construction experience. Ensure that a minimum of three years of experience is in Segmental Box Girder construction operations and includes a minimum of one year in the casting yard operations and related surveying, one year in segment erection and related surveying including post-tensioning and grouting of longitudinal tendons and a minimum of one year as the Project
  - b) Superintendent/Manager in responsible charge of Segmental Box Girder construction operations. Ensure this individual is present at the site of construction, at all times while segmental box girder construction or segment erection is in progress.
- 4) Project Superintendent/Manager-Repair and Rehabilitation: Ensure the Project Superintendent/Manager has a minimum of five years of bridge construction experience or is a registered Professional Engineer with three years of bridge construction experience. Ensure that a minimum of two years of experience is in Segmental Box Girder construction operations and includes a minimum of one year experience performing post-tensioning and grouting of longitudinal tendons and a minimum of one year as the Project Superintendent/Manager in responsible charge of Segmental Box Girder rehabilitation operations or Segmental Box Girder new construction operations.
- 5) Foreman-New Construction: Ensure that the Foreman has a minimum of five years of bridge construction experience with two years of experience in Segmental Box Girder Operations and a minimum of one year as the foreman in responsible charge of Segmental Box Girder new construction Operations. Ensure this individual is present at the site of construction, at all times while segmental box girder construction or segment erection is in progress.
- 6) Foreman-Repair and Rehabilitation: Ensure the Foremen has a minimum of five years of bridge construction experience with two years of experience in Segmental Box Girder Operations and a minimum of one year as the foreman in responsible charge of Segmental Box Girder rehabilitation operations or Segmental Box Girder new construction operations.
- 7) Geometry Control Engineer/Manager:
  - a) Ensure that the Geometry Control Engineer/Manager for construction of cast-in-place box segments is a registered Professional Engineer with one year of experience, a non-registered Engineer with three years of experience or a Registered Professional Land Surveyor with three years of experience in geometry control for casting and erection of cast-in-place box segments. Credit for experience in cast-in-place box girder geometry control will be given for experience in precast box girder geometry control but not vice versa.
  - b) Ensure that the Geometry Control Engineer/Manager for precast box segments is a registered Professional Engineer with one year of experience or non-registered with three years of experience in casting yard geometry control of concrete box segments.
  - c) The Geometry Control Engineer/Manager must be responsible for and experienced at implementing the method for establishing and maintaining geometry control for segment casting yard operations and segment erection operations and must be experienced with the use of computer programs for monitoring and adjusting theoretical segment casting curves and geometry. This individual must be experienced at establishing procedures for assuring accurate segment form setup, post-tensioning duct and rebar alignment and effective concrete placement and curing operations as well as for verifying that casting and erection field survey data has been properly gathered and recorded. Ensure this individual is present at the site of construction, at all times while cast-in-place segmental box girder construction is in progress or until casting yard operations and segment erection is complete.
- 8) Surveyor: Ensure that the Surveyor in charge of geometry control surveying for box segment casting and/or box segment erection has a minimum of one year of bridge construction surveying experience. Ensure this individual is present at the site of construction, at all times while segmental box girder construction or segment erection is in progress.
- e. Movable Bridge Construction: Ensure the individual filling the following positions meet the minimum requirements as follows:
  - 1) Electrical Journeyman: Ensure the Electrical Journeyman holds, an active journeyman electrician's license and has at least five years experience in industrial electrical work, or is a Certified Control Systems Technician. A Certified Control Systems Technician will not be permitted to perform electrical power work including, but not limited to, conduit and wire-way installation or power conductor connection. Ensure the electrical journeyman has successfully completed the installation of one similar movable bridge electrical system during the last three years.
  - 2) Control Systems Engineer and Mechanical Systems Engineer: Ensure the Control Systems Engineer and Mechanical Systems Engineer are both registered Professional Engineers with a minimum of 10 years supervisory experience each in movable bridge construction. Ensure the engineers have working knowledge of the movable

bridge leaf motion control techniques, mechanical equipment and arrangements specified for this project. Ensure that each Engineer has been in responsible control of the design and implementation of at least three movable bridge electrical control and machinery systems within the past 10 years of which, at least one of the three bridges was within the last three years. Ensure that a minimum of one of the three bridge designs incorporated the same type of leaf motion control and machinery systems specified for this project.

f. Concrete Post-Tensioned Other Than Segmental Box Girder Construction: Ensure the individual filling the following positions meet the minimum requirements as follows:

- 1) Project Engineer: Ensure the Project Engineer is a registered Professional Engineer with five years of bridge construction experience. Ensure that a minimum of three years of experience is in concrete post-tensioned construction. Ensure that the three years of experience includes experience in girder erection, safe use of cranes, stabilization of girders; design of false work for temporary girder support, post-tensioning and grouting operations, and a minimum of one year as the Project Engineer in responsible charge of post-tensioning related engineering responsibilities.
- 2) Project Superintendent/Manager: Ensure the Project Superintendent/Manager has a minimum of ten years of bridge construction experience or is a registered Professional Engineer with five years of bridge construction experience and has a minimum of three years of supervisory experience in girder erection, safe use of cranes, stabilization of girders; design of falsework for temporary girder support post-tensioning, grouting operations and a minimum of one year as the Project Superintendent/Manager in responsible charge of post-tensioning related operations.
- 3) Foreman: Ensure the Foremen has a minimum of five years of bridge construction experience with two years of experience in post-tensioning related operations and a minimum of one year as the foreman in responsible charge of post-tensioning related operations.

g. Post-Tensioning (PT) and Grouting Personnel Qualifications: Perform all stressing and grouting operations in the presence of Engineer and with personnel meeting the qualifications of this article. Coordinate and schedule all PT and grouting activities to facilitate inspection by Engineer.

- 1) Post-Tensioning: Perform all PT field operations under the direct supervision of a Level II CTQP Qualified PT Technician who must be present at the site of the post-tensioning work during the entire duration of the operation. For the superstructures of bridges having concrete post-tensioned box or I girder construction, provide at least two CTQP qualified PT technicians, Level I or II, on the work crew. The supervisor of the work crew, who must be a Level II CTQP Qualified PT Technician, may also be a work crew member, in which case, the

supervisor shall count as one of the two CTQP qualified work crew members. For PT operations other than the superstructures of post-tensioned box or I girder construction, perform all PT operations under the direct supervision of a Level II CTQP Qualified PT Technician who must be present at the site of the PT work during the entire duration of the operation. Work crew members are not required to be CTQP qualified.

2) Grouting:

- a) Perform all grouting field operations under the direct supervision of a Level II CTQP Qualified Grouting Technician who must be present at the site of the grouting work during the entire duration of the operation. For the superstructures of bridges having concrete post-tensioned box or I girder construction, provide at least two CTQP qualified grouting technicians, Level I or II, on the work crew. The supervisor of the work crew, who must be a Level II CTQP Qualified Grouting Technician, may also be a work crew member, in which case, the supervisor shall count as one of two CTQP qualified work crew members.
- b) For grouting operations other than the superstructures of post-tensioned box or I girder construction, perform all grouting operations under the direct supervision of a Level II CTQP Qualified Grouting Technician who must be present at the site of the grouting work during the entire duration of the operation. Work crew members are not required to be CTQP qualified.
- c) Perform all vacuum grouting operations under the direct supervision of a crew foreman who has been trained and has experience in the use of vacuum grouting equipment and procedures. Submit the crew foreman's training and experience records to Engineer prior to performing any vacuum grouting operation.

h. Failure to Comply with Bridge Qualification Requirements:

- 1) Make an immediate effort to reestablish compliance. If an immediate effort is not put forth as determined by Engineer, payment for the bridge construction operations requiring supervisors to be qualified under this Specification will be withheld up to 60 days. Cease all bridge construction and related activities (casting yard, etc.) if compliance is not met within 60 days, regardless of how much effort is put forth. Resume bridge construction operations only after written approval from Engineer stating that compliance is reestablished.

9. Prestressed Concrete Plant Quality Control Personnel:

- a. Ensure each prestressed concrete plant has an onsite production manager, an onsite Plant Quality Control Manager, a Plant engineer, and adequate onsite QC inspectors/technicians to provide complete QC inspections and testing.
- b. Ensure the Plant Manager for QC has at least five years of related experience and a current PCI QC personnel Level III certification and a certificate of completion of FDOT Section 450 Specification examination. Ensure that the QC inspector/technician has current PCI QC



Technician/Inspector Level II certification and a certificate of completion of FDOT Section 450 Specification examination.

- c. Ensure that the batch plant operators of the ready mixed concrete batch plants meet the requirements of Section 9.2 of the FDOT Materials Manual. Ensure that the batch plant operators of the onsite centrally mixed concrete plants meet the training requirements of Subarticle 105-F.11.b.4) b) below.

10. Signal Installation Inspector:

- a. Provide an inspector trained and certified by the International Municipal Signal Association (IMSA) as a Traffic Signal Inspector to perform all signal installation inspections. Use only Department approved signal inspection report forms during the signal inspection activities.
- b. Ensure all equipment, materials, and hardware is in compliance with Department Specifications and verify that all equipment requiring certification is listed on the PWWM Traffic Signals And Signs Qualified Products List (TSSQPL) <http://www.miamidade.gov/qpl/>.
- c. Provide the completed signal inspection report form(s), certified by the IMSA Traffic Signal Inspector to Engineer. Sample forms are available at the FDOT webpage <http://www.dot.state.fl.us/trafficoperations> address:

11. Pipe and Precast Concrete Products Manufacturing Facilities Quality Control Personnel:

- a. General: Obtain personnel certifications from FDOT accredited training providers. The list of FDOT approved courses and their accredited providers is available on the State Materials Office website.
- b. Precast Concrete Drainage Structures, Precast Concrete Box Culvert, Precast Concrete Pipe, Incidental Precast Concrete, and Flexible Pipe Manufacturing Facilities Quality Control Personnel:
  - 1) Level I Quality Control Inspectors: Ensure that the Level I Inspectors have completed a minimum of a 12-hour, Department approved, Level I QC Inspector training course in the respective work area. As an exception to this, ensure Flexible Pipe Level I QC Inspectors have completed a minimum of an 8-hour, Department approved, Level I QC Flexible Pipe Inspector training course. For Incidental Precast Concrete, as an alternative to the completion of the 12-hour training course, the Department will accept QC personnel meeting the requirements of Subarticle 105-F.11.b.4)a) below and CTQP Concrete Field Technician level I certification or Precast/Prestressed Concrete Institute (PCI) Quality Control Technician/Inspector Level II certification.
  - 2) Level II Quality Control Inspectors: Ensure that Level II Inspectors have completed FDOT approved Level I QC Inspector training and a minimum of a 5-hour, FDOT approved, Level II QC Inspector training course in the respective work areas. For Incidental Precast Concrete, as an alternative to the completion of the 5-hour training course, the Department will accept CTQP Concrete Field

Technician Level II or PCI Quality Control Level III certifications.

- 3) Plant Quality Control Manager: Ensure that QC Manager has completed FDOT approved Level II QC Inspector training and has a minimum of 2 years construction related experience in the specific work area.
- 4) Additional Requirements for Quality Control Personnel of Precast Concrete Drainage, Precast Concrete Box Culvert, and Incidental Precast Concrete Manufacturing Facilities:
  - a) Testing Personnel: Ensure the personnel performing plastic property tests have ACI Concrete Field Testing Technician-Grade I certification. Ensure the personnel performing laboratory compressive strength testing have ACI Concrete Laboratory Testing Technician-Grade 1 certification or ACI Concrete Strength Testing Technician certification.
  - b) Batch Plant Operator: Ensure the concrete batch plant operator is qualified as a CTQP Concrete Batch Plant Operator. As an alternative to CTQP qualification, the Department will accept the completion of a minimum of a 6-hour, FDOT approved, Batch Plant Operator training course.

12. Structural Steel and Miscellaneous Metals Fabrication Facility Quality Control Personnel:

- a. Ensure each fabrication facility has an onsite production manager, an onsite facility manager for QC, a plant engineer, and on site QC inspectors/technicians to provide complete QC inspections and testing.
- b. Ensure that the Facility Manager for QC and QC inspectors/technicians meet the certification requirements set forth in the latest version of AASHTO/NSBA Steel Bridge Collaboration S 4.1, Steel Bridge Fabrication QC/QA Guide Specification, including the years of experience required in Table 105-1 below. The Facility Manager for QC must meet the requirements of Table 105-1 for every Structural Steel Member Type produced by a plant with QC being managed by the Facility Manager for QC. The Facility Manager for QC will report directly to the plant manager or plant engineer and must not be the plant production manager nor report to or be the subordinate of the plant production manager. QC inspectors/technicians must be the employees of, and must report directly to the Facility Manager for QC.

TABLE 105-1 Experience Requirements for QC Inspectors/Technicians And Facility Manager for Quality Control		
Structural Steel Member Type	Minimum Years of Experience Required	
	QC Inspector/Technician	Facility Manager for QC
Rolled beam bridges	1 year	3 years
Welded plate girders (I sections, box sections, etc.)	2 years	4 years

Complex structures, such as trusses, arches, cable stayed bridges, and moveable bridges	3 years	5 years
Fracture critical (FC) members	3 years	5 years

overhead and cantilevered sign supports, ladders and platforms, bearings, end wall grates, roadway gratings, drainage items, expansion joints, roadway decking, shear connectors, handrails, galvanized products, fencing, guardrail, light poles, high mast light poles, standard mast arm assemblies and Monotube assemblies, stay in-place forms, casing pipe, strain poles, fasteners, connectors and other hardware.

**G. FDOT Quality Control Program.**

1. Producers for the following materials must have an accepted FDOT Quality Control Program during the production of materials to be used on Department projects and be currently listed in the FDOT Materials/Producer Listings and must meet and maintain the approved FDOT Quality Control Program requirements at all times while producing materials that will be incorporated into the Project (<http://www.dot.state.fl.us/statematerialsoffice/quality/programs/qualitycontrol/materialslistings/postjuly2002.shtm>):
  - a. Aggregate
  - b. Asphalt Mix
  - c. Cementitious Material
  - d. Drainage Products
  - e. Earthwork
  - f. Galvanize Metal Products
  - g. Portland Cement Concrete (Structural)
  - h. Prestress/Precast Concrete Products
  - i. Steel and Miscellaneous Metal
  - j. Timber
2. When accreditation or certification is required, make supporting documents from the two previous inspections performed by the accrediting or certifying agency available to the Department upon request.
3. Prestressed Concrete Quality Control Program: Ensure that prestressed concrete plants participating in the FDOT's Acceptance Program are qualified. Obtaining qualification requires a current certification from a FDOT approved precast prestressed concrete plant certification agency and a FDOT approved Quality Control Plan. The list of FDOT approved certification agencies is available on the website of the FDOT State Materials Office.
4. Steel and Miscellaneous Metals Quality Control Program:
  - a. Ensure that the fabricators of Steel and miscellaneous metal products participating in the FDOT's Quality Control Acceptance Program are qualified. Obtaining qualification requires an accepted FDOT Quality Control Plan. A current American Institute for Steel Construction (AISC) certification is a requirement for the Quality Control Acceptance Program of the steel and miscellaneous metal fabricators, provided that AISC certification program is available for the category of the fabrication products.
  - b. Steel and Miscellaneous Metal products, including aluminum, are defined as the metal components of bridges, including pedestrian and moveable bridges,

**107 LITTER REMOVAL AND MOWING (REV. 11-25-2015)**

**A. Description.**

1. Contractor to be responsible for the work below in areas where the County or the property owner has restricted or limited access to maintain the property.
  - a. Provide pickup, removal and disposal of litter within the project limits from the outside edge of travel way to the right of way line. Include the median on divided highways, from the inside edge of travel way to the inside edge of travel way. Litter includes; but is not limited to, bottles, cans, paper, tires, tire pieces, lumber, vehicle parts, metal junk, and brush debris. Exclude any inaccessible areas or areas identified in the Plans as new landscaping in accordance with the Contract Documents.
  - b. Mow turf or vegetation within the project limits. Turf consists of grasses planted in accordance with FDOT Section 570. Vegetation consists of planted and natural grasses, weeds, and other natural vegetation that have been previously mowed. Exclude any areas identified in the Plans as new landscaping in accordance with the Contract Documents.

**B. Operation.**

1. Frequency:
  - a. Remove litter daily from the beginning of the project until final completion, unless otherwise directed by the Engineer. Continue litter removal until final acceptance.
  - b. Begin mowing when directed by the Engineer and continue per the frequency agreed, (every month or less depending of the weather season) unless otherwise directed by the Engineer. Mow all areas to obtain a uniform height of 6 inches. Maintain turf and vegetation height between 6 inches and 12 inches. Do not include seed stalk or wildflowers when measuring height. Continue mowing until final acceptance. After final acceptance perform litter removal and mowing until new turf is established in accordance with FDOT 570-4 at no cost to the County.
  - c. Perform litter removal prior to and in conjunction with mowing; however, the Engineer may direct litter pickups in addition to those performed in conjunction with mowing. Do not mow new turf until a healthy root system is established. In designated wildflower areas, avoid cutting wildflowers when in bloom and when re-seeding.

**2. General:**

- a. Mow shoulders and medians concurrently so that not more than one mile will be left partially mowed at the conclusion of the working day. Mow turf and vegetation on slopes or around appurtenances concurrent with the mowing operation. In areas saturated with standing water, mow or cut to the surface of the water using hand labor or other specialized equipment when standard equipment will cause damage. Do not remove turf or other vegetation cuttings from the right-of-way, or rake or pick up the cuttings unless the cuttings are in the traveled ways, bike lanes, or sidewalk; are obstructing drainage structures; or are the result of cleaning the equipment.
3. Limitations:
- a. Maintain traffic in accordance with Article 102-Maintenance of Traffic. When mowing within four feet of a travel lane, operate the equipment in the same direction of traffic, unless the adjacent lane is closed to traffic due to construction operations. Perform all work during daylight hours.
4. Disposal of Litter and Debris:
- a. During each litter removal cycle, bag and remove all litter or piles at the end of each working day. Dispose of litter in accordance with applicable local and state laws. Do not store or stockpile litter within the project limits.
- C. Method of Measurement.
1. No measure is included for litter removal or mowing.
- D. Basis of Payment.
1. All work and incidental costs specified as being covered under this Article will be included for payment under the several scheduled items of the overall Contract, and no separate payment will be made.

**110 CLEARING AND GRUBBING (REV. 05-16-11)**

A. General.

- 1. Perform all Clearing and Grubbing required by the Contract Documents or necessary to prepare the Project site for the proposed construction.
- 2. Remove and dispose of all structures, material, product and debris not required to be salvaged or not required to complete the construction.
- 3. Trim trees and shrubs within the Project right-of-way that are required by the Contract Documents or necessary for the construction of the Project.
- 4. Perform the work and meet all the requirements for the miscellaneous operations described in Subarticle B.6 herein.
- 5. Protect and do not displace structures which are to remain in place.

B. Clearing and Grubbing:

1. Standard Clearing and Grubbing.

- a. Perform Standard Clearing and Grubbing within:
  - 1) Right-of-way of the roadway to be constructed.
  - 2) All Project areas, whether or not shown in the Plans, that require Clearing and Grubbing including:
    - a) Areas where excavation is to be done.
    - b) Areas where roadway embankments will be constructed.
    - c) Areas where structures will be constructed or installed.
- b. Work includes complete removal and disposal of:
  - 1) All buildings, structures, appurtenances, existing pavement, trees, plants, vegetation, timber, brush, stumps, roots, rubbish, debris, and all other obstructions resting on or protruding through the surface of the existing ground and the surface of excavated areas.
  - 2) All other structures and obstructions necessary to be removed and for which other items of the Contract do not specify the removal thereof.
  - 3) Any boulders encountered in the roadway excavation or found on the surface of the ground unless otherwise permitted by the Contract Documents
- c. Depths of Removal of Roots, Stumps, and Other Debris:
  - 1) Completely remove and dispose of all stumps found within the roadway right-of-way.
  - 2) Remove roots and other debris from all excavated material to be used in the construction of roadway embankment.
  - 3) In all areas where excavation is to be performed or roadway embankments are to be constructed, plow the surface to a depth of at least 6 inches, and remove roots and other debris to a depth of 12 inches below the ground surface.
  - 4) Remove all roots and other debris protruding through or appearing on the surface of the completed excavation within the roadway area and for structures, to a depth of at least 12 inches below the finished excavation surface.
  - 5) In borrow pits, material pits, and lateral ditches, remove or cut off all stumps, roots, etc. below the surface of the completed excavation. Do not perform any clearing or grubbing within 3 feet inside the right-of-way line in borrow and material pits.
  - 6) Within all other areas where Standard Clearing and Grubbing is to be performed, remove roots and other debris projecting through or appearing on the surface of the original ground to a depth of 12 inches below the surface, but do not plow or harrow these areas.
- d. Trees to Remain:

- 1) As an exception to the above provisions, where so directed by the Engineer, trim, protect, and leave standing desirable trees within the Project area.
  - 2) Trim branches of trees extending over the area occupied by the roadway as directed, to give a clear height of 16 feet above the roadway.
2. Selective Clearing and Grubbing.
- a. Perform Selective Clearing and Grubbing only in areas so designated in the Plans or where directed by the Engineer.
  - b. Completely remove and dispose of stumps and remove and dispose of all vegetation, obstructions, etc., as required for Standard Clearing and Grubbing except that, where so elected, the Contractor may cut roots flush with the ground surface.
  - c. Entirely remove undergrowth except in specific areas designated by the Engineer to remain for aesthetic purposes.
  - d. Trim, protect, and leave standing desirable trees, with the exception of such trees as the Engineer may designate to be removed in order to facilitate right-of-way maintenance. Remove undesirable or damaged trees as so designated by the Engineer.
3. Removal of Buildings.
- a. Completely remove all parts of the buildings, including utilities, plumbing, foundations, floors, basements, steps, connecting concrete sidewalks or other pavement, septic tanks, and any other appurtenances, by any practical manner which is not detrimental to other property and improvements. Remove utilities to the point of connection to the utility authority's cut-in.
  - b. After removing the sewer connections to the point of cut-in, construct a concrete plug at the cut-in point, as directed by the Engineer, except where the utility owners may elect to perform their own plugging. Contact the appropriate utility companies prior to removal of any part of the building to ensure disconnection of services.
  - c. Removal by Others: Where buildings within the area to be cleared and grubbed are so specified to be removed by others, remove and dispose of any foundations, curtain walls, concrete floors, basements or other foundation parts which might be left in place after such removal of buildings by others.
4. Removal of Existing Structures.
- a. Structures to be removed include:
    - 1) Structures, or portions of structures, shown in the Plans to be removed;
    - 2) Structures, or portions of structures, found within the areas requiring Clearing and Grubbing, and directed by the Engineer to be removed;
    - 3) Structures, or portion of structures, which are necessary to be removed in order to construct new structures; and
    - 4) All other appurtenances or obstructions which may be designated in the Contract Documents as to be included for removal under this Article.
- b. Removal Requirements:
- 1) General:
    - a) Remove and dispose of all materials from existing structures required to be removed.
    - b) Remove the structures in a neat manner so as to leave no obstructions to any proposed new structures, construction, or to any waterways.
    - c) Pull, cut off, or break off pilings to the requirements of the permit or other Contract Documents, whichever requires the deepest removal, but not less than 2 feet below the finish ground line.
    - d) If Plans indicate channel excavation to be done by others, consider the finish ground line as the limits of such excavation.
    - e) For materials which are to remain the property of the Department or are to be salvaged for use in temporary structures, avoid damage to such materials, and entirely remove all bolts, nails, etc. from timbers to be so salvaged.
    - f) Mark structural steel members for identification as directed.
  - 2) Removal of Steel Members With Hazardous Coatings:
    - a) Provide to the Engineer for approval, a copy of the "Contractor's Lead in Construction Compliance Program" from the firm actually removing and disposing of these steel members before any members are disturbed.
    - b) Vacuum power tool clean any coated steel member to bare metal as defined by SSPC-SP11 a minimum of 4 inches either side of any area to be heated (torch cutting, sawing, grinding, etc.) in accordance with 29 CFR 1926.354. Abrasive blasting is prohibited.
    - c) Provide air supplied respirators in accordance with 29 CFR 1926.62 and 29 CFR 1910.134.
  - c. Partial Removal of Bridges:
    - 1) For all demolition methods, submit for review and approval of the Engineer, a demolition plan that describes the method of removal, equipment to be used, types of rebar splices or couplers, and method of straightening or cutting rebars. In addition, for hydro-demolition, describe the method for control of water or slurry runoff and measures for safe containment of concrete fragments that are thrown out by the hydro-demolition machine.
    - 2) Where concrete is to be removed to neat lines, use concrete saws or hydro-demolition methods capable of providing a reasonably uniform cleavage face. If the equipment used will not provide a uniform cut without surface spalling, first score the outlines of the work with small trenches or grooves.
    - 3) On concrete bridges to be partially removed and widened, remove concrete by manually or mechanically operated pavement breakers, by concrete saws, by chipping hammers, or by hydro-demolition methods. Do not use explosives.

- d. Authority of U.S. Coast Guard: For structures in navigable waters, when constructing the project under authority of a U.S. Coast Guard permit, the U.S. Coast Guard may inspect and approve the work to remove any existing structures involved therein, prior to acceptance by the Department.
  - e. Asbestos Containing Materials (ACM) Not Identified Prior to the Work:
    - 1) When encountering or exposing any condition indicating the presence of asbestos, cease operations immediately in the vicinity and notify the Engineer.
    - 2) Make every effort to minimize the disturbance of the ACM. Immediately provide for the health and safety of all workers at the job site and make provisions necessary for the health and safety of the public that may be exposed to any potentially hazardous conditions. Provisions shall meet all applicable laws, rules or regulations covering hazardous conditions and will be in a manner commensurate with the gravity of the conditions.
    - 3) The Engineer will direct the Prime Contractor when operations may resume in the affected area.
5. Removal of Existing Concrete Pavement.
- a. Remove and dispose of existing rigid portland cement concrete pavement, sidewalk, slope pavement, ditch pavement, curb, and curb and gutter etc., where shown in the plans or ordered by the Engineer to be removed or where required because of the construction operations.
  - b. The work under Removal of Existing Concrete Pavement does not include the removal of retaining walls, drainage structures and flexible asphalt pavement.
6. Miscellaneous Operations.
- a. Water Wells Required to be Plugged:
    - 1) Fill or plug all water wells within the right-of-way, including areas of borrow pits and lateral ditches that are not to remain in service, in accordance with applicable Water Management District rules or the Department of Environmental Protection regulations.
    - 2) Cut off the casing of cased wells at least 12 inches below the ground line or 12 inches below the elevation of the finished excavation surface, whichever is lower. Water wells, as referred to herein, are defined either as artesian or non-artesian, as follows:
      - a) An artesian well is an artificial hole in the ground from which water supplies may be obtained and which penetrates any water-bearing rock, the water in which is raised to the surface by natural flow or which rises to an elevation above the top of the water-bearing bed. Artesian wells are further defined to include all holes drilled as a source of water that penetrate any water-bearing beds that are a part of the artesian water system of Florida, as determined by representatives of the applicable Water Management District.
      - b) A non-artesian (water-table) well is a well in which the source of water is an unconfined aquifer. The water in a non-artesian well does not rise above the source bed.
  - b. Landscape Areas: When certain areas of the right-of-way, outside of the limits of construction, are shown in the plans or designated by the Engineer to be landscaped, either under the construction Contract or at a later time, remove undesirable trees, stumps, undergrowth, and vegetation, as directed, and preserve and trim natural growth and trees as directed by the Engineer.
  - c. Leveling Terrain: Within the areas between the limits of construction and the outer limits of clearing and grubbing, fill all holes and other depressions, and cut down all mounds and ridges. Make the area of a sufficient uniform contour so that the Department's subsequent mowing and cutting operations are not hindered by irregularity of terrain. Perform this work regardless of whether the irregularities were the result of construction operations or existed originally.
  - d. Mailboxes: When the Contract Documents require furnishing and installing mailboxes, permit each owner to remove the existing mailbox. Work with the Local Postmaster to develop a method of temporary mail service for the period between removal and installation of the new mailboxes. Install the mailboxes in accordance with the Design Standards.
- C. Ownership of Materials.
- 1. Except as may be otherwise specified in the Contract Documents, the Contractor shall take ownership of all buildings, structures, appurtenances, and other materials removed by him and shall dispose of them in accordance with subarticle D below.
- D. Disposal of Materials.
- 1. General:
    - a. Dispose of all debris, timber, stumps, brush, roots, rubbish, and other waste material resulting from clearing and grubbing in areas and by methods meeting the applicable requirements of all Local, State and Federal regulations.
  - 2. Disposal of Treated Wood:
    - a. Treated wood, including that which comes from bridge channel fender systems, must be handled and disposed of properly during removal.
    - b. Treated wood should not be cut or otherwise mechanically altered in a manner that would generate dust or particles without proper respiratory and dermal protection.
    - c. Treated wood must be disposed of in at least a lined solid waste facility or through recycling/reuse.
    - d. Treated wood shall not be disposed by burning or placement in a construction and demolition (C&D) debris landfill.
    - e. All compensation for the cost of removal and disposal of treated wood will be included in the Cost of Removal of Existing Structures when an item for direct payment

is provided in the Contract. If an item of direct payment is not provided in the Contract, the aforementioned cost is included in the cost for Clearing and Grubbing or among the other items of work in the Contract.

### 3. Hazardous Materials/Waste:

#### a. General:

- 1) Handle, transport and dispose of hazardous materials in accordance with all Local, State and Federal requirements including the following:
  - a) SSPC Guide 7
  - b) Federal Water Pollution Control Act, and
  - c) Resource Conservation and Recovery Act (RCRA).
- 2) Accept responsibility for the collection, sampling, classification, packaging, labeling, accumulation time, storage, manifesting, transportation, treatment and disposal of hazardous waste, both solid and liquid. Separate all solid and liquid waste and collect all liquids used at hygiene stations and handle as hazardous materials/waste. Obtain written approval from the Engineer and required agencies for all hazardous materials/waste stabilization methods before implementation.
- 3) Obtain an EPA/FDEP Hazardous Waste Identification Number (EPA/FDEP ID Number) before transporting and/or disposal of any hazardous materials/waste.
- 4) List the Department as the generator of all hazardous materials/waste.
- 5) Submit the following for the Engineers' approval before transporting, treatment or disposal of any hazardous materials/waste:
  - a) Name, address and qualifications of the transporter,
  - b) Name, address and qualifications of the treatment facility,
  - c) Proposed treatment and/or disposal of all Hazardous Materials/Waste.
- 6) Transport all hazardous materials/waste in accordance with applicable 40 CFR 263 Standards. Provide a copy of all completed Hazardous Materials/Waste manifest/bills of lading to the Engineer within 21 days of each shipment.

#### b. Steel Members With Hazardous Coating:

- 1) Unless otherwise required by the Contract Documents, dispose of steel members with hazardous coating in one of the following manners:
  - a) Deliver the steel members and other hazardous waste to a licensed recycling or treatment facility capable of processing steel members with hazardous coating.
  - b) Deliver any other hazardous materials/waste to a licensed hazardous materials/waste recycling treatment facility.

- 2) Dismantle and/or cut steel members to meet the required dimensions of the recycling facility, treatment facility or other regulatory agency.
- 3) All compensation for the cost of removal and disposal of hazardous materials/waste will be included in the Cost of Removal of Existing Structures when an item for direct payment is provided in the Contract. If an item of direct payment is not provided in the Contract, the aforementioned cost is included in the cost for Clearing and Grubbing or among the other items of work in the Contract.

#### c. Certification of Compliance:

- 1) Furnish two copies of Certification of Compliance from the firm actually removing and disposing of the hazardous materials/waste stipulating, the hazardous materials/waste has been handled, transported and disposed of in accordance with this Specification.
- 2) The Certification of Compliance shall be attested to by a person having legal authority to bind the company.

- d. Maintain all records required by this Specification and ensure they are available to the Department upon request.

### E. Method of Measurement.

#### 1. Clearing and Grubbing:

- a. No Direct Payment Provided: When no item for direct payment of Clearing and Grubbing is provided by the Contract, the costs for performing all work and meeting the requirements of this Article will be included among the various scheduled items of the Contract.
  - b. Direct Payment Provided: When direct payment for Clearing and Grubbing is provided in the Contract, the quantity to be paid for will be the lump sum quantity.
2. One or more of the following items may appear in a contract where no direct payment item for Clearing and Grubbing is provided. Only those items with an Awarded Unit Price will be considered for direct payment. All other work of Clearing and Grubbing is included among the various scheduled items of the Contract.
    - a. Removal of Existing Structures: When a separate item for the Removal of Existing Structures is provided for direct payment in the Contract, the quantity to be paid for will be the lump sum quantity or actual quantities for the specific structures removed, as stipulated in the Contract Documents.
    - b. Removal of Existing Concrete Pavement: When a separate item for Removal of Existing Concrete Pavement is provided for direct payment in the Contract, the quantity to be paid for will be the number of square yards of existing pavement of the types listed in subarticle B.5 herein, acceptably removed and disposed of, as specified. The quantity will be determined by actual measurement along the surface of the pavement before its removal. Measurements for appurtenances which have irregular surface configurations, such as curb and gutter, steps, and

ditch pavement, will be the area as projected to an approximate horizontal plane. Where the removal of pavement areas is necessary only for the construction of box culverts, pipe culverts, storm sewers, french drains, inlets, manholes, etc., these areas will not be included in the measurements.

- c. Removal of Trees: When separate items for the Removal of Trees are provided for direct payment in the Contract, trees that are greater than 6 inches in diameter, will be paid on a per each basis by actual count by the Engineer of such trees under the appropriate item provided in the Contract. The diameter of a tree shall be obtained by measuring its circumference at 4.5 feet above the ground using a flexible tape measure and dividing the circumference by 3.14. If the tree is growing on a slope, the circumference is measured at 4.5 feet from the center of the slope. If the tree begins to branch below 4.5 feet, measure at the smallest circumference below the first branch.
- d. Plugging Water Wells: When a separate item for Plugging of Water Wells is provided for direct payment in the Contract, the quantity to be paid for will be the number of water wells plugged, for each type of well (artesian or non-artesian).
- e. Mailboxes: When a separate item is provided in the Contract for furnishing and installing mailboxes, the quantity to be paid for will be the number of mailboxes acceptably furnished and installed.
- f. Delivery of Salvageable Material to the Department: When a separate item is provided in the Contract for the delivery of salvageable material to the Department, the quantity to be paid for will be the Lump Sum quantity for delivery of salvageable materials to the Department as indicated in the Plans or as directed by the Engineer.

#### F. Basis of Payment.

##### 1. Clearing and Grubbing:

- a. No Direct Payment Provided: When direct payment for Clearing and Grubbing is not provided in the Contract, the cost of any work of clearing and grubbing necessary for the proper construction of the Project and meeting all requirements of this Article, is included in the Contract price for the structure or other item of work for which such clearing and grubbing is required.
- b. Direct Payment Provided:
  - 1) Price and payment will be full compensation for all clearing and grubbing indicated or required for the construction of the entire Project, including all necessary hauling, furnishing equipment, equipment operation, furnishing any areas required for disposal of debris, leveling of terrain and the landscaping work of trimming, etc., as specified herein, except for any areas designated to be paid for separately or to be specifically included in the costs of other work under the Contract.
  - 2) Unless otherwise provided by the Contract, price and payment will be full compensation for all work required by this Article including Removal of Existing Structures, Removal of Existing Concrete Pavement, Removal of Trees, Plugging of Water

Wells, Mailboxes, and Delivery of Salvageable Material to the Department.

- 3) Where construction easements are specified in the Plans and the limits of clearing and grubbing for such easements are dependent upon the final construction requirements, no adjustment will be made in the lump sum price and payment, either over or under, for variations from the limits of the easement defined on the Plans.

- c. The Contractor shall include the cost of all clearing and grubbing which might be necessary in pits or areas from which base material is obtained in the Contract price for the base in which such material is used.
- d. The clearing and grubbing of areas for obtaining stabilizing materials, where required only for the purpose of obtaining materials for stabilizing, will not be paid for separately.

##### 2. Removal of Existing Structures:

- a. Price and payment will be full compensation for all work of removal and disposal of the designated structures.
- b. When direct payment for the removal of existing structures is not provided in the Contract, the cost of removing all structures is included in the Contract price for Clearing and Grubbing or, if no item of Clearing and Grubbing is included, in the compensation for the other items covering the new structure being constructed.

##### 3. Removal of Existing Concrete Pavement:

- a. Price and payment will be full compensation for performing and completing all the work of removal and satisfactory disposal including any saw cutting required.
- b. When direct payment for the removal of existing concrete pavement is not provided in the Contract and no applicable item of excavation or embankment covering such work is included in the Contract, the Contractor shall include the costs of this work in the Contract price for the item of Clearing and Grubbing or, if no item of Clearing and Grubbing is included in the Contract, in any work, pipe or other structure for which the concrete pavement removal is required.

##### 4. Removal of Trees:

- a. Price and payment will be full compensation for complete removal and disposal of each tree counted by the Engineer pursuant to these specifications.
- b. When direct payment for the removal of trees is not provided in the Contract, the cost of removing all trees is included in the Contract price for Clearing and Grubbing or, if no item of Clearing and Grubbing is included in the Contract, in the compensation for all other items in the Contract.

##### 5. Plugging Water Wells:

- a. Price and payment will be full compensation for each type of well acceptably plugged.
- b. When direct payment for plugging water wells is not provided in the Contract, the cost plugging water wells is included in the Contract price for Clearing and Grubbing or, if no item of Clearing and Grubbing is

included in the Contract, in the compensation for all other items in the Contract.

6. Mailboxes:

- a. Price and payment will be full compensation for all work and materials required, including supports and numbers.
- b. When direct payment for mailboxes is not provided in the Contract, the cost for all work and materials required, including supports and numbers, is included in the Contract price for Clearing and Grubbing or, if no item of Clearing and Grubbing is included in the Contract, in the compensation for all other items in the Contract.

7. Delivery of Salvageable Material to the Department:

- a. Price and payment will be full compensation for all work required for delivery of the materials to the Department.
- b. When the Contract does not provide direct payment for the Delivery of Salvageable Material that is to be delivered to the County, the cost of Delivery of Salvageable Material is included in the Contract price for Clearing and Grubbing or, where no item for Clearing and Grubbing is included in the Contract, in the compensation for all other items in the Contract.

8. Payment Items: Payment will be made under:

Item No.	Description	Unit
110-82	Remove and Dispose Structural Timber	MB



## **SECTION 7: SPECIAL PROVISIONS**

## SPECIAL PROVISIONS

**SPECIAL PROVISIONS**  
**TABLE OF CONTENTS**

**1. GENERAL REQUIREMENTS**

---

1.01	MISCELLANEOUS CONSTRUCTION CONTRACTS (MCC) PLAN. GENERAL TERMS AND CONDITIONS AND SPECIAL CONDITIONS.....	1
1.02	SCOPE OF WORK.....	1
1.03	LOCATION OF WORK.....	2
1.04	PLANS.....	2
1.05	TIME FOR COMPLETION.....	2

**2. GENERAL CONSTRUCTION**

---

2.01	FIELD OFFICE.....	3
------	-------------------	---

**3. GENERAL CONSTRUCTION**

---

3.01	CONCRETE SPALL REPAIRS.....	4
------	-----------------------------	---

APPENDIX "A" TO SPECIAL PROVISIONS

Authorization Agreement for Automatic Deposit

APPENDIX "B" TO SPECIAL PROVISIONS

Technical Specifications

## 1. GENERAL REQUIREMENTS

---

### 1.01 MISCELLANEOUS CONSTRUCTION CONTRACTS (MCC) PLAN. GENERAL TERMS AND CONDITIONS AND SPECIAL CONDITIONS

- A. Division 01 (General Requirements) of the DTPW Specifications amends the MCC Plan, and other provisions of the Contract Documents. All requirements of the MCC Plan, Resolution and amendments', or portions thereof, which are not specifically modified, deleted, or superseded by Division 01, remain in full effect. In the event a conflict between these two complementary portions of the Contract Documents occurs, Division 1 will prevail and Engineer will provide a clarification and final determination. These Special Provisions also amend, complement, modify or delete items from the DTPW Construction Specifications of these Solicitation and Contract Documents.

### 1.02 SCOPE OF WORK

- A. Work under this Contract includes furnishing of all supervision, labor, materials, tools, equipment and performing all operations required to construct the Work in accordance with the Contract Documents.
- B. Tasks to be performed includes, but is not limited to the following:
  - 1. Remove components from the existing damaged timber fender system including, wales, spacer blocks, catwalk planks, deck supports, all associated connections and wire ropes, and Install new wales, spacer blocks, catwalk planks, deck supports, wire ropes and handrail at both bridges.
  - 2. Remove and replace fender navigational light system at both bridges.
  - 3. Remove and replace existing damaged ladders platforms at both bridges.
  - 4. Remove and replace existing damaged roof tiles at both bridge tender houses. Care to be taken not to allow any damaged tile to fall into water or adjacent sidewalk area. Damaged tile not eligible for repair to be disposed of in accordance with plans.
  - 5. Remove and replace bitumen roof at the East Bridge Generator Building.
  - 6. Repair spalls with exposed reinforcing as per specifications and plans at existing fender concrete piles, at both bridges.
  - 7. Repair spalls with exposed reinforcing as per specifications and plans and repair concrete deck slab spalls at the East Bridge Generator Building.
  - 8. Repair existing walls, clean and paint the exterior walls and steel gate at the East Bridge Generator Building.
- C. If any changes are required due to conflict of design and or field conditions, the Engineer will make the final determination.
- D. Contractor and all subcontractors, under this Contract, are prohibited from performing any work, other than specified in the Contract and/or directed by the Engineer, within the limits of the project

site, without prior written notification to the Engineer. This includes any work for private or commercial entities.

### 1.03 LOCATION OF WORK

- A. The location of work to be performed under the terms of this Contract shall be as follows:
  - 1. Bridge No. 874459 (Venetian West Bascule) and Bridge No. 874474 (Venetian East Bascule) at the Fender System, Tender Houses and the East Bascule Generator House.
  - 1. The exact location and limits of construction are as shown on the Plans accompanying these Contract Documents.

### 1.04 PLANS

- A. Engineering Drawings titled "Plans for Proposed Improvements to Venetian Causeway Bridge No. 874459 and No. 874474 – Hurricane Irma Repairs", Miami Dade County Project No. EDP – MT – 20200094 Venetian Causeway Maintenance; Prepared by Miami Dade County, Department of Transportation and Public Works, Highway Division, are included with these Contract Documents. Additional standard details are available in the Miami-Dade County Public Works Manual and the latest edition of the Florida Department of Transportation's Design Standards for Design, Construction, Maintenance and Utility Operations on The State Highway System.
- B. The County through its Engineer shall have the right to modify the details and/or sketches, to supplement the sketches with additional plans and/or with additional information as work proceeds; all of which shall be considered as plans accompanying these Specifications herein generally referred to as the "Plans." In case of disagreement between the Plans and Specifications, the Engineer shall make a final determination as to which shall govern.

### 1.05 TIME FOR COMPLETION

- A. The Work must be substantially completed within 270 days after the date when the Contract Time commences to run as provided in Subarticle 1.06 N of the General Requirements (Division 1), and all requirements of the Contract Documents completed and ready for final payment within 330 days after the date when the Contract Time commences to run.
- B. The effective date of the "Notice to Proceed" will be established during the Preconstruction Conference which is held shortly after the Award of Contract and which is attended by members of Department of Transportation and Public Works, the Contractor, representatives of utility companies, and others affected by the Work. The effective date shall be set as a date no later than 30 calendar days after the date of execution of the Contract Documents, unless a later date acceptable to both parties is agreed upon in writing.

## **2. GENERAL CONSTRUCTION**

---

### **2.01 FIELD OFFICE**

- A. A local field office is not required; however, the Contractor will be required to provide the Engineer with a local (Miami-Dade County) telephone or cellular number, where the Contractor may be contacted 24 hours a day, 7 days a week during the period for which the Contract is in force.

### **3. GENERAL CONSTRUCTION**

---

#### **3.01 CONCRETE SPALL REPAIRS**

- A. Contractor is responsible to comply with all the requirements and Technical Specifications for Concrete Spall Repairs. Refer to Appendix "B" to Special Provisions of the Contract Documents.
- B. All cost associated to comply with the above requirements are to be included under pay item number 401-70-2.

APPENDIX "A" TO SPECIAL PROVISIONS  
AUTHORIZATION AGREEMENT FOR AUTOMATIC DEPOSIT







## ACH AUTHORIZATION AGREEMENT FOR AUTOMATIC DIRECT DEPOSIT OF MIAMI-DADE COUNTY WARRANTS

### INSTRUCTIONS

Please contact us at (305) 375-5111 or email at [FIN-ACHN@miamidade.gov](mailto:FIN-ACHN@miamidade.gov) if you have any questions or need assistance with this form.

You may obtain blank copies of this form at : [http://www.miamidade.gov/finance/library/ach\\_form.pdf](http://www.miamidade.gov/finance/library/ach_form.pdf)

At our Vendor Payment Inquiry (VPI) website you can obtain payment information as well as status of invoices, payment due date and other important information. You can reach the VPI site at :

<https://w85exp.miamidade.gov/VInvoice/login.do>

### Section 1

#### Transaction Type

New : If vendor is currently not on ACH deposits with Miami-Dade County.

Change : If vendor is currently on ACH deposits with Miami-Dade County and would like to make changes to their information ( example : change of financial institution, account number, etc.)

Terminate : If vendor is currently on ACH deposits with Miami-Dade County and would like to switch to either Check or AP Control disbursement type )

**Federal Identification Number** : Enter your Federal Employer Identification Number (FEIN) or Social Security Number (SSN) used to register you as a vendor with Miami-Dade County. Name and FEIN/SS must be exactly as provided on IRS Form W-9.

**Vendor Name** : Enter the name of your business or individual name used to register you as a vendor with Miami-Dade County.

**DBA (Doing Business As )** : If you have registered a DBA for your business or for you as an individual, please enter it here.

**Fiscal Officer Name, Title and E-Mail** : Name of Authorized Corporate officer, Title and E-Mail address to be contacted to. Corporate officer signing this form must be an authorized signatory in the corporate bank account listed on this form.

**ACH Notification E-Mail** : This is the E-Mail address where payment information will be sent to.

### Section 2

This section must be completed in full and legible manner by your banking institution in order to prevent delays in processing change to ACH.

Both acknowledgment statements must be checked off by Bank Official signing and dating the form.

### Section 3

This section will be completed by Miami-Dade County Finance Department.

#### ORIGINAL FORM AND VOIDED CHECK OR REDACTED STATEMENT MUST BE MAILED TO :

##### Accounts Payable Manager

Miami-Dade County Finance Department

111 NW First Street, Suite 2620

Miami, Florida 33128

#### Terms and Conditions

Completed form should not contain any changes (scratched off /white out) or altered information; otherwise, form will not be accepted.

Processing time is approximately fifteen (15) days from receipt of complete form and voided check or redacted Bank statement.

Providing account information does not authorize Miami-Dade County to access bank account activity.

ACH deposits can be made into **only** one (1) bank account. Payments can not be split between multiple accounts.

Notification E-mail providing payment information can be sent to one (1) single E-mail address **only**.

Proper verification will be conducted by Miami-Dade County Finance Department Staff, via a telephone call to confirm the information being provided is accurate.

This authorization shall remain in effect until terminated in writing with sufficient notice to Miami-Dade County Finance Department.

Miami-Dade County will not be responsible for any loss that may arise solely by reason of error, mistake or fraud regarding information provided on this ACH Authorization Agreement Form.

APPENDIX "B" TO SPECIAL PROVISIONS  
TECHNICAL SPECIFICATIONS

**TECHNICAL SPECIAL  
PROVISION FOR  
CONCRETE SPALL REPAIRS  
BRIDGE NO. 874459 & 874474  
VENETIAN CAUSEWAY OVER ICWW**

**Project No. 20200094**

**Department of Transportation and Public Works, Miami-Dade County**

These plans have been prepared in accordance with and are governed by the Miami-Dade County Public Works Department Standards and Specifications parts 1, 2, and 3 revised as follows:

*I hereby certify that this specifications package has been properly prepared by me, or under my responsible charge, in accordance with procedures adopted by the Florida Department of Transportation.*

The official record of this package has been electronically signed and sealed using a Digital Signature as required by Rule 61G15-23.004, F.A.C. Printed copies of this document are not considered signed and sealed and the signature must be verified on any electronic copies.

Prepared by Oscar J. Cruz, PE  
Date: 05/04/2021  
Fla. License No.: 63889  
Firm Name: Chrome Engineering, Inc.  
Firm Address: 16650 N Kendall Drive, Suite 205  
City, State, Zip code: Miami, Florida, 33196  
Certificate of Authorization: 032891  
Page(s): 2-7



Prepared By: \_\_\_\_\_  
Oscar J. Cruz, P.E.  
P.E. # 63889  
Date: May 4, 2021

## SECTION T401 CONCRETE REPAIR AND RESTORATION

To be applied at Venetian Causeway Bridges No. 874459 and 874474 Fenders and Generator Building Repair.

### **T401-1. Scope of work:**

The work under this section consist of restoring cracked or spalled concrete on the existing concrete piles on the fenders at bridge No. 874459 and 874474, and the East Generator Building roof concrete slab as directed by the Engineer using pump or pour methods.

**T401-1.1 General:** Repairs will require phased work at specific components where the structural integrity of the component may be affected due to the amount of required concrete removal as determined by the Engineer. Specific work includes the following: locate and document cracked and unsound concrete, concrete removal; surface preparation, repairing broken rebar, concrete restoration by means of patching and/or forming, testing, and correcting electrical continuity of the reinforcement.

**T401-1.2 Quantities:** Due to the nature of the deterioration present on the fender concrete piles and the generator building, Miami Dade Department of Transportation Public Works (DTPW) shall have the authority to increase, decrease, or delete the quantities of work to be performed in excess or below the percentages allowed by the Section 4-3.1 of the Standard Specifications and revisions thereto with no adjustment to the contract unit prices. The work will be assigned by the Engineer for a specific group of locations at a time.

In addition to the locations of spalls shown in the Plans, the Contractor shall perform a sounding survey of the generator building and identify all locations in need of repair. The survey shall be performed in the presence of the Engineer prior to commencing any work.

No concrete removal shall be performed without the Engineer's approval. DTPW shall be allowed to reject work due to poor workmanship, unapproved materials, or unapproved work procedure at any time without consequence to DTPW.

**T401-1.3 Tracking Repair Quantities:** The Contractor shall prepare a detailed report with the identified areas documented as per T401-1.2 indicating the square footage of each spall along with an estimated total amount of repairs. The report shall be formatted to indicate precise location of each area, estimated quantities for each type of repair (concrete repair) and calculations for each. This document will be used by the Engineer for preparing the authorization to proceed with repairs and by the Contractor to track quantities. The Contractor shall update the report on a monthly basis to include actual quantities of repairs and remaining budget available to continue with repairs. Repairs performed after exhaustion of budget due to Contractor's failure to track quantities or other knowledge that contract funds are exhausted will be solely at the Contractor's expense.

DTPW shall determine the size of the work assignments. No work shall commence on any new work assignment until the satisfactory completion or substantial progress (i.e., more than 40%

completion) of previously issued assignments has been confirmed, except when the Engineer determines that such other work is in the best interest of DTPW and gives written instructions to proceed. The Contractor will be expected to begin work within 14 calendar days following issuance of the authorization to proceed with Work.

**T401-1.4 Work Vessels:** The Contractor shall use a proper size vessel or barges to execute the work and house all the equipment taking into consideration site conditions, open rough seas, strong currents, and winds at the site. DTPW will not allow additional time for work delays due to rough waters if it determines that the chosen equipment was not adequate for the conditions existing at the site.

A gasoline or diesel fuel powered emergency boat with communication equipment (phone or radio) shall be at the job site at all times when work is being performed. At no time shall any worker be present at the job site without immediate transportation to shore in the event of an emergency. The emergency boat shall be in addition to the boat provided for DTPW inspectors under SP 005091 and shall not be used as a work platform.

**T401-1.5 Staging of Work:** The concrete repair work shall be performed from the water using a proper size vessel or barges provided with lifts and other devices as required in order to complete the work. During work hours the vessels or barges can be tied to the bents as long as rubber bumpers or other devices are provided to protect the bent from damage. Therefore, location of equipment on the roadway or on the bridge will not be permitted unless otherwise approved by the Engineer for specific operations. Mooring shall not be permitted at the bridge. If mooring is used, any potential mooring areas shall be identified and submitted to the Engineer for approval. Additionally, prior to mooring, the Contractor shall obtain approval of a mooring anchor from the National Marine Sanctuary. If spudding is used, the Contractor shall obtain approval for spudding from the National Marine Sanctuary. The vessel/barge shall be removed from bridge at night unless work is in progress.

Some spalls are located at top of existing concrete piles, and at concrete slab of the generator building roof slab, which may require an access system for repairs. This access system is included in the contract price. The Contractor shall also be responsible for removing all anchors and patching all holes created to support forms, false work, etc. with an appropriate approved mortar or epoxy. However, no anchoring to the beams will be permitted. No permanent attachments or modifications to the structure for the purpose of staging the work will be allowed on any bridge component.

**T401-1.6 Shop Drawings:** Provide shop drawings indicating type of form system including supports, method of concrete placement, and containment of concrete and waste materials. Containment is the responsibility of the Contractor, and approval will ultimately be based upon continued performance.

**T401-1.7 Work Plan and Work Schedule:** Submit a detailed work plan and schedule for all the types of work as stated in the Plans and the Technical Special Provision for review and approval by the Engineer prior of beginning any work.

## **T401-2. Materials and Testing:**

Use a pre-packed, latex modified (polymer concrete) for typical spall repairs. All Class IV and Class V (Special) concrete shall be in accordance with FDOT Standard Specifications and properties based on Florida Lime rock Aggregate.

**T401-2.1 Latex Modified (Polymer Concrete)** (Item 401-70-2): Pre-packaged concrete for spall repairs shall be an approved latex modified (polymer concrete) unless otherwise indicated in the Contract Documents for specific components. The selected material shall have a minimum compressive strength of 5,500 psi at 28 days for Class IV concrete and 6,000 psi for Class V (Special) and shall be produced and marketed for pump and/or pour applications. Repair materials shall not exceed a maximum chloride content of 0.4 pounds of chloride per cubic yard of material when placed.

Use an extended material per the manufacturer's instructions for all spalls extending deeper than one inch. Aggregates shall meet all applicable Department specifications or have a certification from the patching material manufacturer indicating satisfactory performance when incorporated to his product.

Pre-packaged patch materials and aggregates shall be kept at a clean, dry location away from contaminants.

**T401-2.2 Patch Mortar** (Item 401-70-2): Use Pre-packaged patch repair mortar for spalls less than one inch deep. The patch mortar shall be suitable for hand application on horizontal or vertical spalls and shall have a minimum compressive strength of 5,500 psi. for Class IV concrete and 6,000 psi for Class V (Special)

**T401-2.3 Bonding Agent:** An approved concrete bonding agent shall be applied to the existing concrete and reinforcing steel prior to placement of the new concrete and/or patching material. Such bonding compound shall be solvent free; epoxy-cement based; and shall not perform as a vapor barrier. The bonding compound used shall contain corrosion inhibitors and shall be suitable for application over concrete and reinforcement with a minimum application time of 1 hour after mixing. The bonding compound shall be mixed and applied as per manufacturer's specifications.

**T401-2.4 Manufacturer's Technical Data Sheets:** Provide manufacturer's certifications for the following materials:

- 1) Pre-packed concrete repair materials including formulation and aggregates: shall include technical data indicating compliance with contract requirements. All aggregates added in the field shall be from an FDOT approved source unless certified satisfactory by the concrete material manufacturer.
- 2) Concrete bonding compound: data sheet and Material Safety Data Sheets (MSDS) Abrasive blasting material data sheet and MSDS.

**T401-2.5 Concrete Materials Testing:** In addition to the quality control required by the Standard Specifications for concrete products, compressive strength, and plastic testing will also be required for each field batch of latex modified (polymer concrete) material used for spall repairs.

A field batch is defined as each load of the concrete mixer when field batching is approved. Sampling schedule for field batching may be reduced as directed by the Engineer based on satisfactory previous test results and adequate Contractor's quality control. Six cube samples (2" x 2" x 2") will be used for testing purposes when un-extended mortar is used as the repair material. When extended, prepare test cylinders as for FDOT approved design concrete mixes.

Produce and test a trial mix with the proposed spall repair materials prior to commencing any concrete work. Test all plastic properties to demonstrate compliance with manufacturer's data. Prepare compressive strength specimens for testing at 7, 14, and 28 days.

The QC Plan for concrete, pre-packed material, design mixes, and general work plan for the specific tasks shall be approved by the Engineer prior to commencing the specific work for that mix. Failure to obtain approval of any of the above shall not be grounds for granting additional contract time.

### **T401-3. Construction Methods for Concrete Restoration:**

#### **T401-3.1 Construction Methods:**

**T401-3.1.1 Concrete Removal:** All cracked, delaminated, or hollow sounding concrete shall be removed and repaired as designated in the Contract Documents and/or as directed by the Engineer. Concrete with Class 1 (0 to 1/64 in.) cracks, but solid when sounded, may not need to be removed and repaired if directed by the Engineer. When Class 1 cracks are encountered, the Contractor shall notify the Engineer for inspection and direction.

In addition, solid concrete to a depth ranging from 3/4 to 1 inch shall be removed from behind the reinforcement for achieving a mechanical bond between the repair material and the reinforcement, for locating rebars for continuity corrections, and for location of reinforcing steel not affected by corrosion. Remove sound concrete for mechanical bond to a maximum distance of 6 inches from the edge of the spall after the perimeter is sawcut if the rebar is not corroded and is fully exposed at the edge of the spall. Should rebar be corroded, remove concrete until non-corroded reinforcing steel is reached. Cut vent grooves prior to placing concrete when needed to prevent voids due to air pockets.

Provide a substrate with a minimum surface profile of ICRI-CPS5 (1/8" to 1/4") at the existing and new concrete interface unless a deeper profile is specified by the repair material manufacturer.

Clean concrete of dust, dirt, residue, oyster shells, oil, grease, marine growth, existing coatings, and debris that may be present by media blasting or other approved method. Blast clean existing concrete surfaces that will be in contact with the freshly placed repair material. Remove all loose material and dust, and rinse concrete with fresh water immediately prior to the application of the repair material.

**T401-3.1.2 Concrete Removal Tools:** Only hand tools, light duty (30 lb. max) pneumatic or electric chippers and electric or air saws may be used for the concrete removal. Use only 15 lb. (max) chippers when working adjacent to bars or strands.



During the concrete removal process, great care shall be exercised to prevent damage to the reinforcing steel and prevent damage to sound concrete beyond the delaminated areas, sound concrete beyond the mechanical bond areas, or sound concrete beyond the continuity correction areas. Should reinforcing steel or sound concrete, as described above, be damaged by the Contractor's operation, concrete removal work in that area shall stop, and a damage report shall be submitted to the Engineer.

A repair method for the damaged area(s) shall be submitted for approval by the Engineer prior to continuing the concrete removal work in that area.

**T401-3.1.3 Perimeter of Spall:** The perimeter of the spalls shall be saw cut to a depth ranging from  $\frac{3}{4}$ " to 1" prior to forming or placing the concrete. Adjust depth of sawcut if shallow steel is encountered as approved by the Engineer. Provide horizontal and vertical cuts that follow the general pattern of the spall avoiding 90-degree angles as the geometry of the spall permits. Roughen the faces of the concrete along the saw cut to provide a profile optimal for bond. Where cracking may occur with 90-degree angles, 45-degree angle cuts shall be performed.

**T401-3.2 Reinforcing Steel:** All reinforcing steel shall be maintained at original position and all exposed steel shall be sandblasted clean to a near white condition as to meet SSPC PC6 standards prior to concrete placement. No traces of rust, mill scale, epoxy or other contaminants shall be present after sandblasting. Special attention shall be observed to ensure proper cleaning and preparation of the backside of these bars and/or strands. Replace bars that lost 20% or more of its cross-sectional area with new bars spliced in place, lapping as to develop full strength of the bar as shown in the Plans.

**T401-3.3 Placing and Finishing:** Do not place any repair material when the temperature is below 45 degrees F or when the temperature range exceeds that recommended by the material manufacturer.

**T401-3.3.1 Finishing:** Concrete spall repairs shall be smooth and uniform and shall match the original profile of the concrete components. Concrete placement methods shall be adjusted as necessary to avoid gaps between the existing concrete and the concrete patching material. No gaps larger than 0.013 inch will be allowed at cold joints as it would interrupt the continuity of the metalizing to follow.

**T401-3.3.2 Bonding Agent Application:** An approved bonding agent shall be applied to the entire spall area and all exposed reinforcing steel (rebar or strand). Mixing, application and curing shall be performed as per manufacturer's specifications. Mixed material shall be uniform in appearance. No lumps or irregularities shall be allowed. Application time shall not exceed manufacturer's specified pot life.

**T401-3.3.3 Forms:** Placement of the forms and pouring shall be completed as soon as practical after blasting and before any contaminant is present, not to exceed 72 hours or the maximum allowed time required by the bonding agent manufacturer, whichever is the shorter. Forms must withstand the anticipated head pressure of the repair material. Install proper venting on the forms as to ensure complete filling of the inside. Pump material to the bottom of the form to ensure proper air vent. Cap the vents when all air has been removed and maintain pumping

pressure until an increase of 3 to 6 psi is observed and close the port.

If placing the concrete by pour methods, provide shoots, and maintain these full to produce a standing head pressure on the material. Remove shoots and excess material after the material has set.

All forms shall be capable of withstanding internal and/or external vibration. All formed concrete corners shall be chamfered  $\frac{3}{4}$  inch in accordance with section 400-5.4.1 of the Standard Specifications unless otherwise noted in the Contract Document.

**T401-3.3.4 Curing:** The concrete shall be form cured for a minimum of 7 days before removing the forms. Form curing time may be extended by the Engineer based on site conditions. Ambient exposed areas of formed concretes shall be wet cured for the same amount of time as for form curing. Every effort shall be made to avoid shrinkage cracking of the poured concrete including, but not limited to external cooling in the forms, or wet burlap curing after removal of the forms. The Contractor shall remove all forms and anchors and seal all form anchor holes after curing time has been approved by the Engineer.

**T401-4. Method of Measurement:**

**401-4.1 Measurements:** Unless otherwise approved by the Engineer, all measurements shall be taken horizontally and vertically for each depth of repairs. The method or combination of methods of measurements shall be those which will reflect, with reasonable accuracy, the actual volume of finished concrete work as determined by the Engineer.

**T401-4.2 Quantities:** The quantity for pre-packed latex modified (polymer concrete) for spall repairs shall be paid for based on the volume of material furnished, placed, and accepted in accordance with the Contract Documents.

**T401-5. Basis of Payment:**

**T401-5.1 Concrete Repairs:** Price and payment for concrete repairs shall provide full compensation for all related items including but not limited to: materials; equipment; labor; structure survey; concrete removal; saw-cutting; surface preparation; continuity testing and correction; connection plates; bonding agent application; forming; curing; under water work; and any incidentals as applicable necessary to complete the work.

Pay Item No. 401-70-2	Restore Spalled Area. (Latex Modified Mortar Styrene-Butadine)	Cubic Feet
-----------------------	---	------------

**END OF TECHNICAL SPECIAL PROVISIONS**

## **SECTION 8: ENGINEERING DRAWINGS**

ENGINEERING DRAWINGS ARE PROVIDED SEPARATELY