

PLANS FOR PROPOSED
DRAINAGE IMPROVEMENTS TO
RAINTREE LAKES
NE 24 AVENUE AND NE 197 STREET AND
NE 25 AVENUE FROM
NE 200 STREET TO NE 202 STREET
MIAMI-DADE COUNTY PROJECT NO.20240287
FUNDING SOURCE: STORMWATER UTILITY

INDEX OF SHEETS

SHT. No.	SHEET DESCRIPTION
1	COVER SHEET
2	GENERAL NOTES
3	SURVEYOR'S NOTES, KEY SHEET, LEGEND AND ABBREVIATIONS
4-5	DRAINAGE PLAN
6	PROPOSED DRAINAGE STRUCTURE TABLE, CONFLICT TABLE AND SUMMARY OF QUANTITIES
7	STANDARD DETAILS
8	TURBIDITY BARRIER
9	SEDIMENT BARRIERS DETAILS
10	INLET PROTECTION SYSTEMS DETAILS
11	STORMWATER POLLUTION PREVENTION PLAN

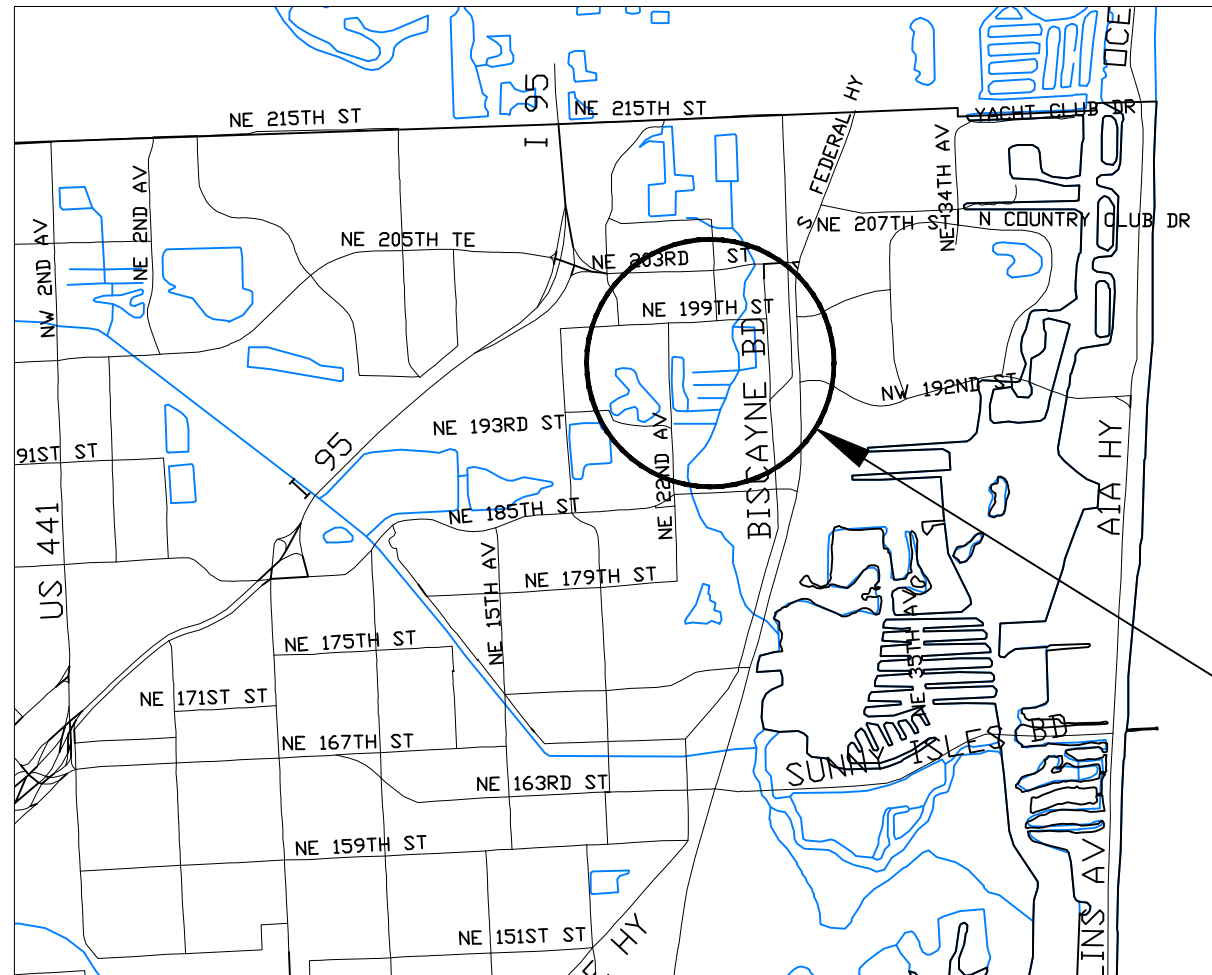

NOTE:
ATTENTION IS DIRECTED TO THE FACT THAT THESE PLANS MAY HAVE BEEN REDUCED IN SIZE BY REPRODUCTION. THIS MUST BE CONSIDERED WHEN OBTAINING SCALED DATA.

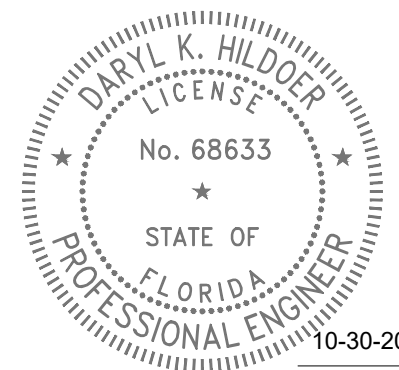
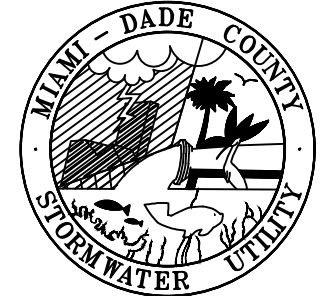

PROJECT LOCATION

THESE PLANS HAVE BEEN PREPARED IN ACCORDANCE WITH AND ARE GOVERNED BY THE MIAMI-DADE COUNTY PUBLIC WORKS DEPARTMENT STANDARDS AND SPECIFICATIONS PARTS 1, 2 AND 3. THE MANUAL OF UNIFORM MINIMUM STANDARDS FOR DESIGN, CONSTRUCTION AND MAINTENANCE FOR STREETS AND HIGHWAYS. THE FLORIDA DEPARTMENT OF TRANSPORTATION ROADWAY AND TRAFFIC DESIGN STANDARDS, AND THE FLORIDA DEPARTMENT OF TRANSPORTATION STANDARD SPECIFICATIONS, AS AMENDED BY CONTRACT DOCUMENTS.



PREPARED BY



MIAMI-DADE COUNTY DEPARTMENT OF
TRANSPORTATION AND PUBLIC WORKS
ROADWAY ENGINEERING AND
RIGHT OF WAY DIVISION
STORMWATER DRAINAGE DESIGN SECTION

STEPHEN P. CLARK CENTER
111 NW 1 ST, SUITE 1510
MIAMI, FLORIDA 33128

THIS ITEM HAS BEEN DIGITALLY SIGNED AND SEALED BY DARYL K. HILDOER, P.E. ON THE DATE ADJACENT TO THE SEAL.

PRINTED COPIES OF THIS DOCUMENT ARE NOT CONSIDERED SIGNED AND SEALED AND THE SIGNATURE MUST BE VERIFIED ON ANY ELECTRONIC COPIES.

DESIGN	G.S.	CHECK	D.H.
		DRAWN	H.S.
DATE	8-22-25	SHEET	1 OF 11

C:\Users\ve139108\AppData\Local\Temp\Temp\MapPublish_13928\SH-1 COVER SHEET.dwg Sep 24, 2025 - 6:32am E:139108

GENERAL NOTES:

1. ALL ELEVATIONS REFER TO THE MSL, 1929 NATIONAL GEODETIC VERTICAL DATUM (NGVD)
2. ALL DRAINAGE CONSTRUCTION SHALL BE IN STRICT ACCORDANCE WITH THE PERMITTING REQUIREMENTS OF MIAMI DADE COUNTY REGULATORY AND ECONOMIC RESOURCES AND THE MIAMI-DADE COUNTY DEPARTMENT OF TRANSPORTATION AND PUBLIC WORKS.
3. IT IS THE INTENT THESE PLANS TO BE IN ACCORDANCE WITH APPLICABLE CODES AND AUTHORITIES HAVING JURISDICTION. ANY DISCREPANCIES BETWEEN THESE PLANS AND APPLICABLE CODES SHALL BE IMMEDIATELY BROUGHT TO THE ATTENTION OF THE ENGINEER.
4. CATCH BASINS, SEEPAGE DRAINS, PAVEMENT RESTORATION AND PAVEMENT AROUND CATCH BASINS TO BE ACCORDING TO THE DETAILS AND APPLICABLE REQUIREMENTS OF THE MIAMI-DADE COUNTY DEPARTMENT OF TRANSPORTATION AND PUBLIC WORKS.
5. WHERE NEW PAVEMENT MEETS EXISTING, CONNECTION SHALL BE MADE IN A NEAT STRAIGHT LINE AND FLUSH WITH EXISTING PAVEMENT.
6. CONTRACTOR IS TO VERIFY THE EXACT LOCATION OF ALL EXISTING TREES, STRUCTURES, AND UTILITIES WITH MAY NOT BE SHOWN ON PLANS. ANY EXISTING STRUCTURE, PAVEMENT, TREES OR OTHER EXISTING IMPROVEMENT NOT SPECIFIED FOR REMOVAL WHICH IS TEMPORARILY DAMAGED, EXPOSED OR IN ANY WAY DISTURBED BY CONSTRUCTION PERFORMED UNDER THIS CONTRACT, SHALL BE REPAIRED, PATCHED OR REPLACED AT NO ADDITIONAL COST TO THE OWNER.
7. THE LOCATION AND SIZE OF ALL EXISTING UTILITIES SHOWN ON THESE DRAWINGS ARE APPROXIMATE. ADDITIONAL UTILITIES MAY EXIST WHICH ARE NOT SHOWN ON THESE DRAWINGS. THE CONTRACTOR SHALL BE RESPONSIBLE FOR THE LOCATION OF ALL EXISTING UTILITIES. THE CONTRACTOR SHALL VERIFY ALL UTILITIES BY ELECTRONIC METHODS AND BY HAND EXCAVATION IN COORDINATION WITH ALL UTILITY COMPANIES. PRIOR TO BEGINNING ANY CONSTRUCTION OPERATION AND ALL CONFLICTS OF EXISTING UTILITIES WITH PROPOSED IMPROVEMENTS MUST BE RESOLVED BY THE ENGINEER AND THE OWNER. THIS WORK BY THE CONTRACTOR SHALL BE CONSIDERED INCIDENTAL TO THE CONTRACT AND NO ADDITIONAL COMPENSATION SHALL BE ALLOWED.
8. CONTRACTOR SHALL CONTACT THE SUNSHINE STATE ONE CALL OF FLORIDA, INC. AT 1 (800) 432-4770 AT LEAST 48 HOURS PRIOR TO PERFORMING ANY DIGGING TO VERIFY THE EXACT LOCATION OF EXISTING UTILITIES.
9. EXISTING TREES SHALL BE REMOVED ONLY IF REQUIRED FOR CONSTRUCTION. THOSE TREES NOT INTERFERING WITH CONSTRUCTION SHALL BE PROTECTED IN PLACE. THE CONTRACTOR IS ADVISED THAT A TREE PERMIT MAY BE REQUIRED FOR TREE REMOVAL. CONTRACTOR SHALL NOTIFY REGULATORY AND ECONOMIC RESOURCES DEPARTMENT AND MUNICIPALITIES WITH JURISDICTION PRIOR TO REMOVING ANY TREES.
10. EXISTING GRADES WERE TAKEN FROM THE BEST AVAILABLE DATA AND MAY NOT ACCURATELY REFLECT PRESENT CONDITIONS. CONTRACTOR SHALL BE RESPONSIBLE FOR FAMILIARIZING HIMSELF WITH CURRENT SITE CONDITIONS, AND SHALL REPORT ANY DISCREPANCIES TO THE ENGINEER PRIOR TO STARTING WORK.
11. THE CONTRACTOR SHALL PREPARE AND SUBMIT SHOP DRAWINGS FOR ALL ITEMS LISTED IN PROJECT SPECIFICATION.
12. UNDER NO CIRCUMSTANCES SHALL THE CONTRACTOR LEAVE EXCAVATED TRENCHES, OR PARTS OF, EXPOSED OR OPEN AT THE END OF THE WORKING DAY, WEEKENDS, HOLIDAYS OR OTHER TIMES. WHEN THE CONTRACTOR IS NOT WORKING, UNLESS OTHERWISE DETERMINED, ANY TRENCH SHALL BE COVERED, FIRMLY SECURED AND MARKED ACCORDINGLY FOR PEDESTRIAN TRAFFIC.
13. THE CONTRACTOR SHALL MAINTAIN ACCESS TO ALL ADJACENT PROPERTIES AT ALL TIMES.
14. ALL EXCAVATED MATERIAL REMOVED FROM THIS PROJECT SHALL BE DISPOSED OF PROPERLY BY THE CONTRACTOR AT THE CONTRACTOR'S EXPENSE.
15. CAST IRON PRODUCTS: HEAVY-DUTY CLASSIFICATION SUITABLE FOR HIGHWAY TRAFFIC LOADS, OR 16,000 LB. WHEEL LOADS.
16. STEEL GRATING AND COVERS: TRAFFIC CLASSIFICATION H-20 AASHTO H20: 16,000 LBS. OVER 8' X 20" AREA.
17. ALL STRUCTURES MUST BE CAPABLE OF SUSTAINING HEAVY TRAFFIC LOADS.
18. ALL GRASS AREAS AFFECTED BY CONSTRUCTION SHALL BE RE-SODDED.
19. THE CONTRACTOR SHALL BE RESPONSIBLE FOR THE PROVISION, INSTALLATION AND MAINTENANCE OF ALL TRAFFIC CONTROL AND SAFETY DEVICES, IN ACCORDANCE WITH SPECIFICATIONS OUTLINED IN SECTION C2 AND SECTION R19 OF THE PUBLIC WORKS DEPARTMENT MANUAL. IN ADDITION, THE CONTRACTOR IS RESPONSIBLE FOR THE RESETTling OF ALL TRAFFIC CONTROL AND INFORMATION SIGNING REMOVED DURING CONSTRUCTION PERIOD.
20. EXCAVATED OR OTHER MATERIAL STORED ADJACENT TO OR PARTIALLY UPON A ROADWAY PAVEMENT SHALL BE ADEQUATELY MARKED FOR TRAFFIC SAFETY AT ALL TIMES.
21. TEMPORARY PATCH MATERIAL MUST BE ON THE JOB SITE WHENEVER PAVEMENT IS CUT, OR THE INSPECTOR WILL SHUT THE JOB DOWN.
22. CONTRACTOR SHALL MAINTAIN TRAFFIC ACCORDING TO CORRESPONDING TYPICAL CONTROL DETAIL AS OUTLINED IN MIAMI-DADE COUNTY PUBLIC WORKS MANUAL.
23. CONTRACTOR SHALL MAINTAIN AT LEAST THE FOLLOWING NUMBER OF TRAFFIC LANES FOR CORRESPONDING TIME PERIODS: MONDAY - FRIDAY 7-9 A.M. AND 4-6 P.M.; NO INTERRUPTION TO TRAFFIC IS PERMITTED. ALL OTHER TIMES:
 - A) MAINTAIN ONE LANE FOR TWO-WAY OPERATION WITH FLAGMEN.
 - B) MAINTAIN ONE LANE IN EACH DIRECTION FOR TRAFFIC.
24. CONTRACTOR MUST PROVIDE FLASHER ARROW BOARD FOR ANY LANE THAT IS CLOSED OR DIVERTED.
25. CONTRACTOR SHALL NOTIFY LAW ENFORCEMENT AND FIRE PROTECTION SERVICES TWENTY-FOUR (24) HOURS IN ADVANCE OF THE DETOUR IN ACCORDANCE WITH SECTION 336.07 OF FLORIDA STATUTES.
26. COMPLETE AS-BUILT INFORMATION RELATIVE TO LOCATION AND DEPTH OF PIPES, MANHOLES, ETC. SHALL BE ACCURATELY RECORDED BY THE CONTRACTOR. THREE (3) SETS LABELED "AS-BUILT" MUST BE SUBMITTED, SIGNED AND SEALED BY A PROFESSIONAL ENGINEER REGISTERED IN THE STATE OF FLORIDA, TO THE ENGINEER OF RECORD PRIOR TO FINAL ACCEPTANCE OF THE WORK.
27. IT IS RESPONSIBILITY OF THE CONTRACTOR TO SELECT AND OBTAIN THE APPROPRIATE PERMISSION FROM MIAMI-DADE COUNTY OR APPLICABLE AGENCY THAT HAS JURISDICTION ON THE "PROPOSED" STAGING AREAS.

28. DRAINAGE/UTILITY TRENCHES SHALL NOT BE LEFT OPEN OVERNIGHT. A TEMPORARY COVER WITH A CAPACITY OF H-20 LOADING SHALL BE PLACED AS DIRECTED BY THE ENGINEER AT NO EXTRA COST TO MIAMI-DADE COUNTY.
29. PROVIDE FLOWABLE FILL OVER PIPE AS COVER WHERE MINIMUM PIPE COVER OF 2 FEET CANNOT BE ACCOMPLISHED UNDER PAVED AREAS. HOWEVER, THE COVER WITH FLOWABLE FILL SHALL BE NO LESS THAN 12 INCHES.
30. ALL STATIONS AND OFFSETS REFER TO [CENTERLINE]/ [BASELINE] OF CONSTRUCTION, UNLESS OTHERWISE STATED.
31. CONTRACTOR SHALL COMPLY WITH THE REQUIREMENTS OF THE EPA AND THE NATIONAL POLLUTION DISCHARGE ELIMINATION SYSTEM (NPDES).
32. MIAMI-DADE WATER AND SEWER DEPARTMENT REQUIRES THAT ACCESS TO ALL WATER AND SEWER VALVES, SANITARY MANHOLES, AND OTHER CONTROL MECHANISMS BE MAINTAINED THROUGHOUT CONSTRUCTION IN THE EVENT OF AN EMERGENCY TO ENSURE THE PUBLIC HEALTH AND SAFETY. COVERING VALVE BOXES AND MANHOLES CAN BE CONSIDERED UNAUTHORIZED CONSTRUCTION OF AND TAMPERING WITH DEPARTMENT UTILITIES. ALL REQUESTS FOR UTILITY ADJUSTMENTS MUST BE MADE IN WRITING AT LEAST TWO (2) WEEKS IN ADVANCE. FOR MANHOLE AND VALVES, CONTACT UTILITY COORDINATOR PATRICK CHONG AT 786-268-5255. THE DEPARTMENT WILL MAKE ONE FINAL AND PERMANENT ADJUSTMENT AT NO COST TO THE REQUESTING AGENCY. FOR THE ADJUSTMENT OF WATER METERS, CONTACT THE CHIEF OF METER OPERATIONS AND MAINTENANCE: 786-268-5469. FOR ANY FIRE HYDRANTS THAT ARE DAMAGED OR BUMPED DURING CONSTRUCTION, CONTACT THE MDWASD HYDRANT SHOP AT 305-552-4926, BEFORE POURING CONCRETE FOR THE SIDEWALK. IN THE EVENT OF A WATER OR SEWER EMERGENCY, WASD EMERGENCY NUMBER 305-552-8901. THIS LINE IS OPEN 24 HOURS, 7 DAYS A WEEK.
33. THE CONTRACTOR IS ADVISED THAT PROPERTIES ADJACENT TO THE PROJECT HAVE ELECTRIC, TELEPHONE, GAS, WATER AND/OR SEWER SERVICE LATERALS WHICH MAY NOT BE SHOWN IN PLANS. THE CONTRACTOR MUST REQUEST THE LOCATION OF THESE LATERAL SERVICES FROM THE UTILITY COMPANIES. THE ADDITIONAL COST OF EXCAVATING, INSTALLING, BACKFILLING, AND COMPACTING AROUND THESE SERVICES MUST BE INCLUDED IN THE BID RELATED ITEM FOR THE WORK BEING DONE.
34. THE CONTRACTOR SHOULD TAKE SPECIAL NOTE OF SOIL CONDITIONS THROUGHOUT THIS PROJECT. ANY SPECIAL SHORING, SHEETING OR OTHER PROCEDURES NECESSARY TO PROTECT ADJACENT PROPERTY, PUBLIC OR PRIVATE, DURING THE EXCAVATION OF SUBSOIL MATERIAL AND EXFILTRATION TRENCH, OR FILLING OF ANY AREA, OR FOR ANY OPERATION DURING CONSTRUCTION, SHALL BE THE SOLE RESPONSIBILITY OF THE CONTRACTOR.
35. IF SHEETING, SHORING OR DEWATERING, INCLUDING WELL POINTS ARE NECESSARY, THE CONTRACTOR MUST MONITOR AND CONTROL ALL WORK THAT MAY CAUSE CRACKING TO ANY ADJACENT BUILDING, STRUCTURE, OR PROPERTY AREA. THE CONTRACTOR SHALL BE RESPONSIBLE FOR ANY DAMAGES CAUSED BY THESE OPERATIONS. COST OF SHEETING, SHORING, OR DEWATERING, SHALL BE INCLUDED IN THE RELATED BID ITEM FOR THE WORK BEING DONE.
36. ALL DITCH EXCAVATIONS SHALL BE PERFORMED IN FULL COMPLIANCE WITH THE PROVISIONS OF THE TRENCH SAFETY ACT.
37. ANY KNOWN OR SUSPECTED HAZARDOUS MATERIAL FOUND ON THE PROJECT BY THE CONTRACTOR SHALL BE IMMEDIATELY REPORTED TO THE PROJECT ENGINEER, WHO SHALL DIRECT THE CONTRACTOR TO PROTECT THE AREA OF KNOWN OR SUSPECTED CONTAMINATION FROM FURTHER ACCESS. THE ENGINEER WILL ARRANGE FOR INVESTIGATION, IDENTIFICATION, AND REMEDIATION OF THE HAZARDOUS MATERIAL. THE CONTRACTOR SHALL NOT RETURN TO THE AREA OF CONTAMINATION UNTIL APPROVAL IS PROVIDED BY THE PROJECT ENGINEER.
38. THE CONTRACTOR SHALL USE A STREET SWEEPER (USING WATER) OR OTHER EQUIPMENT CAPABLE OF CONTROLLING AND REMOVING DUST. APPROVAL OF THE USE OF SUCH EQUIPMENT IS CONTINGENT UPON ITS DEMONSTRATED ABILITY TO DO THE WORK.
39. WHEN DISSIMILAR MATERIAL CONNECTIONS ARE MADE, SUCH AS CONCRETE TO METAL, THE DISSIMILAR MATERIAL SHALL BE SEPARATED BY COATING THE CONTACT SURFACE WITH BITUMASTIC MATERIAL.
40. PRIOR TO CONSTRUCTION THE CONTRACTOR WILL INSPECT ALL EXISTING STRUCTURES WHICH ARE TO REMAIN AND NOTIFY THE ENGINEER OF ANY OBVIOUS STRUCTURAL DEFICIENCIES.
41. WHERE CONNECTIONS TO EXISTING SIDEWALKS AND DRIVEWAYS ARE NOT INDICATED ON PLANS, PROPER CONNECTIONS ARE TO BE MADE AS DIRECTED BY THE ENGINEER. DROP CURB AND DRIVEWAY CONNECTIONS SHALL BE PROVIDED FOR ACCESS TO ALL PRIVATE PROPERTIES ADJACENT TO THE PROJECT. PAYMENT SHALL BE INCLUDED IN THE COST OF RELATED BID ITEMS.
42. CONTRACTOR TO INSTALL 1/2" PERFORMED EXPANSION JOINT WHEN PROPOSED SIDEWALK IMPROVEMENTS IS IMMEDIATELY ADJACENT TO EXISTING CONCRETE SLAB AND/OR BUILDING.
43. THE SIDEWALK AT DRIVEWAY TURNOUTS SHALL BE 6" CONCRETE.
44. ALL BUS STOP SIGNS TO BE FURNISHED BY MIAMI-DADE TRANSPORTATION AND PUBLIC WORKS DEPARTMENT. ENGINEER TO CONTACT MIAMI-DADE COUNTY TRANSPORTATION AND PUBLIC WORKS DEPARTMENT AT (305) 637-3753 ONE (1) WEEK PRIOR TO POURING SIDEWALKS AND COORDINATE THE REMOVAL AND REPLACEMENT OF BUS STOP SIGNS AND BENCHES.
45. THE INFORMATION PROVIDED IN THESE DRAWINGS IS SOLELY TO ASSIST THE CONTRACTOR IN ASSESSING THE NATURE AND EXTENT OF CONDITIONS WHICH WILL BE ENCOUNTERED DURING THE COURSE OF WORK. THE CONTRACTORS ARE DIRECTED, PRIOR TO BIDDING, TO CONDUCT WHATEVER INVESTIGATIONS THEY DEEM NECESSARY TO ARRIVE AT THEIR OWN CONCLUSION REGARDING THE ACTUAL CONDITIONS THAT WILL BE ENCOUNTERED AND UPON WHICH BIDS WILL BE BASED.
46. ANY SURVEY MONUMENT, BENCH MARK, ETC., FOUND DURING CONSTRUCTION ACTIVITIES ARE TO BE RESTORED TO IT IS ORIGINAL LOCATION AND COORDINATES AS DEPICTED IN COUNTY RECORDS PLAT AND BOOK. RESTORATION WILL BE AT NO ADDITIONAL COST AND MUST BE SHOWN ON AS-BUILT PLANS.
47. FOR THE INSTALLATION OF SOD IN SWALE AREAS ADJACENT TO ROADWAYS, SIDEWALKS, DRIVEWAY APPROACHES OR ANY OTHER PAVED SURFACES, THE SWALE MUST BE RESTORED TO FORM A "V" SHAPE AS PER THE DETAILS INCLUDED IN THE MIAMI DADE COUNTY PUBLIC WORKS MANUAL. SPECIFICALLY, THE ELEVATION OF THE TOP OF THE SOD MUST MATCH THE ABUTTING AREAS (EDGE OF PAVEMENT, SIDEWALK OR DRIVEWAY APPROACH) AND THE CENTERLINE OF THE SWALE SHALL BE ON AVERAGE 3 INCHES BELOW THE ROADWAY EDGE OF PAVEMENT ELEVATION UNLESS OTHERWISE DIRECTED BY THE ENGINEER.
48. ANY DRAINAGE IMPROVEMENT PROJECT REQUIRING THE RESURFACING OF THE ENTIRE ROADWAY INTERSECTION WILL REQUIRE THE CONTRACTOR TO UPGRADE THE EXISTING RAMPS AND CONNECTORS SITUATED WITHIN THE INTERSECTION TO ADA STANDARDS, AS NECESSARY. IF NO RAMPS AND CONNECTORS ARE PRESENT, THE CONTRACTOR MUST INSTALL NEW ADA COMPLIANT SIDEWALK RAMPS AND CONNECTORS. THIS REQUIREMENT IS CONTINGENT UPON THE PRESENCE OF EXISTING SIDEWALKS REQUIRING CONNECTION.

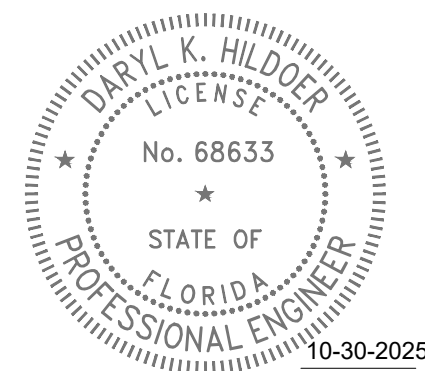

THIS ITEM HAS BEEN DIGITALLY SIGNED AND SEALED BY DARYL K. HILDOER, P.E. ON THE DATE ADJACENT TO THE SEAL.

PRINTED COPIES OF THIS DOCUMENT ARE NOT CONSIDERED SIGNED AND SEALED AND THE SIGNATURE MUST BE VERIFIED ON ANY ELECTRONIC COPIES.

REVISIONS

DATE	BY	DESCRIPTION	DATE	BY	DESCRIPTION

RAINTREE LAKES
 NE 24 AVENUE AND NE 197 STREET
 AND NE 25 AVENUE FROM NE 200
 STREET TO NE 202 STREET
 DRAINAGE IMPROVEMENT PROJECT

NAME	DATE	NAME	DATE
DESIGNED BY: G.S.	8-22-25	DRAWN BY: H.S.	8-22-25
CHECKED BY: F.G.	8-22-25	CHECKED BY: F.G.	8-22-25
SUPERVISED BY:			

DEPARTMENT OF TRANSPORTATION AND PUBLIC WORKS
 ROADWAY ENGINEERING AND RIGHT OF WAY DIVISION
 STEPHEN P. CLARK, CENTER
 111 NW 135
 MIAMI, FLORIDA 33128

GENERAL NOTES

C:\Users\el139108\AppData\Local\Temp\AcPublish_13928\SH-02 - NOTES.dwg Sep 24, 2025 - 8:33am E139108

SURVEYOR'S NOTES:

-Survey performed by DTPW Survey Section.
 -Survey Date: 09/27/2024
 -Survey as per: F.B. 3016 Page:46-53
 -(NE 197 STREET AND NE 24 AVENUE)
 -The elevations are based on NGVD 1929, Miami Dade County
 Name=N-3100
 BM Elev=8.64'
 NE 199 ST = 51' South of ϵ ; NE 22 AVE=33' East of ϵ
 *PK Nail & Brass Washer in Concrete Sidewalk
 -Section 04, Township 52 , Range 42.;
 -Survey performed by DTPW Survey Section.
 -Survey Date: 03/28/2024
 -Survey as per: F.B. 3007 Page:19-21
 -(20011 NE 25 AVE)
 -The elevations are based on NGVD 1929, Miami Dade County
 Name=N-469
 BM Elev=5.93'
 NE 203 ST = North Side; NE 24 AVE= 170' W of West E/Pav
 15' S. of Back of Walk, 110' E.S.E. of Conc Light Post
 *PK Nail & Brass Washer in Top of Catch Basin
 -Section 33, Township 51 , Range 42.
 -Benchmark for vertical control information was recorded
 by DTPW Survey Section.
 -Right-of-Way Lines shown hereon as per existing plats.

LOCATION MAP & KEY MAP

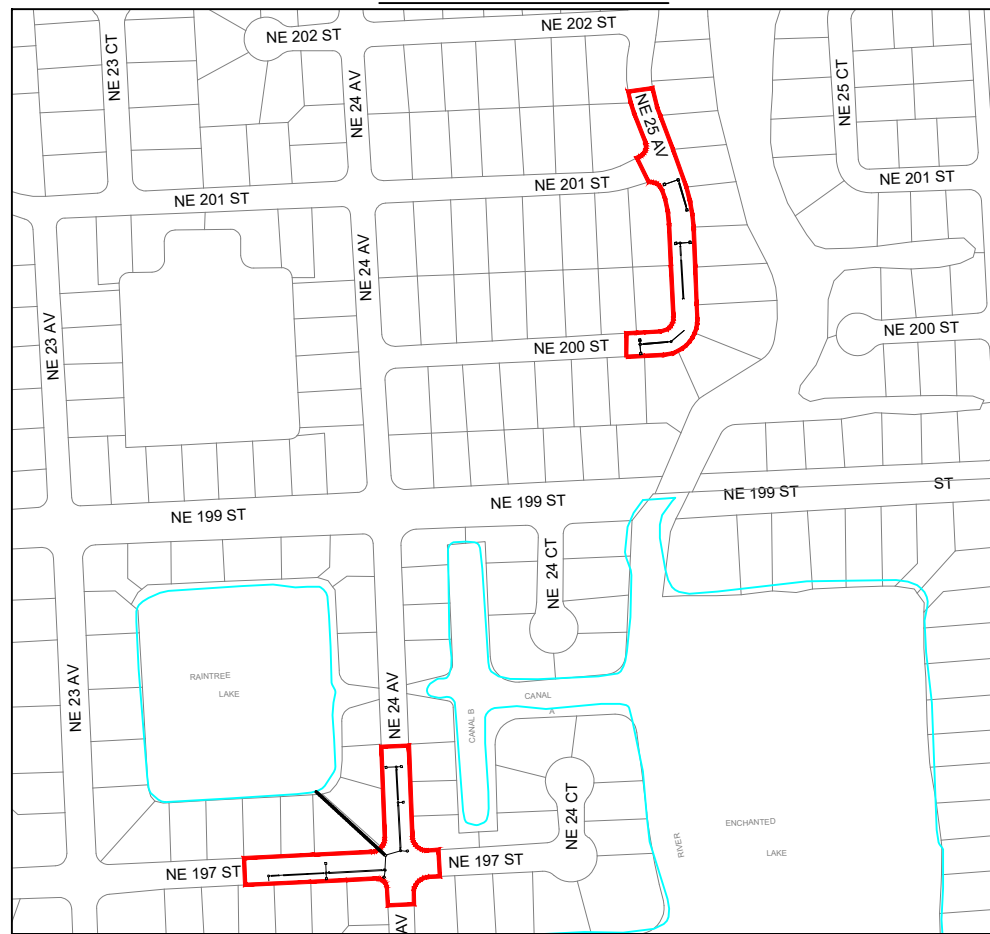

KEY SHEET
TRS 52-42-04 & TRS 51-42-33

LEGEND AND ABBREVIATIONS:

- (M) = MEASURES
- (P) = By PLAT
- F, Fd = FOUND
- CND = CONCRETE NAIL & DISK
- PKF = PK NAIL FOUND
- CNDF = CONCRETE NAIL & DISK FOUND
- CNF = CONCRETE NAIL & DISK FOUND
- CNC = CONCRETE NAIL CUT
- DHF = DRILL HOLE FOUND
- NF = NAIL FOUND
- PKDF = PK NAIL & DISK FOUND
- R/W = RIGHT OF WAY
- RBAC = ROCK BASE ASPHALT COMPOUND
- B = BASE LINE
- C = CENTER LINE
- R = RADIUS
- L = LENGTH OF CURVE
- C&G = CURB & GUTTER
- VG = VALLEY GUTTER
- E/P = EDGE OF PAVEMENT
- T/B = TOP OF BANK
- E/W = EDGE OF WATER
- PCP = PERMANENT CONTROL POINT
- RLS = REGISTERED LAND SURVEYOR
- PLS = PROFESSIONAL LAND SURVEYOR
- S = STREET SIGN
- ALF = ALUM. FLASHING SCHOOL LIGHT
- M = MAILBOX
- DLP = DECORATIVE LIGHT POLE
- MLP = METAL LIGHT POLE
- MTP = METAL TRAFFIC LIGHT POLE
- MPP = METAL POWER POLE
- CLP = CONCRETE LIGHT POLE
- CPP = CONCRETE POWER POLE
- WLP = WOOD LIGHT POLE
- WPP = WOOD POWER POLE
- WTP = WOOD TELEPHONE POLE
- FLP = FIBERGLASS LIGHT POLE
- WM = WATER MANHOLE
- SM = SANITARY MANHOLE
- SSV = SANITARY SEWER VALVE (FM)
- CTP = CABLE TV PEDESTRIAN
- TCRB = TV CABLE RISER BOX
- TCB = TV CONTROL BOX
- CB = CABLE BOX
- TH = TELEPHONE HANDHOLE
- TM = TELEPHONE MANHOLE
- TUB = TELEPHONE UTILITY BOX
- TRB = TELEPHONE RISER BOX
- TRCB = TELEPHONE RISER CONTROL BOX
- TECB = TELEPHONE CONTROL BOX
- B = BOX
- CS = CROSSING SIGN
- P = POST
- I = INTERCOM
- GV = GAS VALVE
- PV = PVC POST
- GW = GUY WIRE
- SH = SPRINKLE HEAD
- CAC = CENTRAL ANGLE OF CURVE
- MW = MONITORING WELL
- PP = PETROLEUM PIPELINE
- EH = ELECTRIC HANDHOLE
- EM = ELECTRIC MANHOLE
- FH = FIRE HYDRANT
- WV = WATER VALVE
- WM = WATER METER
- TSM = TRAFFIC SIGH MANHOLE
- TSH = TRAFFIC SIGH HANDHOLE
- TTCB = TRAFFIC CONTROL BOX
- TTCB = TRAFFIC SIGNAL BOX
- ECB = ELECTRICAL CONTROL BOX
- RRCL = RAIL ROAD CROSSING (LIGHT)

- [Pattern] = CONCRETE
- [Pattern] = ASPHALT
- [Pattern] = UNIMPROVED DRIVEWAY
- [Pattern] = GRAVEL
- [Pattern] = BRICK
- [Pattern] = STAMPED CONCRETE
- [Pattern] = CONCRETE BLOCK FENCE
- [Symbol] = TREE DIAMETER
- [Symbol] = EXISTING CATCH BASIN
- [Symbol] = EXISTING STORMWATER MANHOLE
- [Symbol] = PROPOSED CATCH BASIN
- [Symbol] = PROPOSED STORMWATER MANHOLE
- [Line] = EXISTING SOLID PIPE
- [Line] = EXISTING FRENCH DRAIN
- [Line] = PROPOSED SOLID PIPE
- [Line] = PROPOSED FRENCH DRAIN
- [Line] = RIGHT-OF-WAY LINE
- [Line] = WOOD FENCE
- [Line] = CHAIN LINK FENCE
- [Line] = IRON FENCE
- [Line] = EXISTING SIDEWALK
- [Line] = F.P.L. OVERHEAD
- [Line] = F.P.L. UNDERGROUND
- [Line] = WATER LINE MAIN
- [Line] = GAS MAIN
- [Line] = FORCE MAIN
- [Line] = C-TV
- [Line] = BELL SOUTH TELEPHONE CONDUIT
- [Line] = BASELINE
- [Line] = SANITARY SEWER

- [Symbol] = AVOCADO TREE
- [Symbol] = ARECA TREE
- [Symbol] = AUST. PINE TREE
- [Symbol] = ALMOND TREE
- [Symbol] = BLACK OLIVE TREE
- [Symbol] = BOTTLE BRUSH TREE
- [Symbol] = BISMARCK PALM
- [Symbol] = BUSH TREE
- [Symbol] = BISCHOFIA TREE
- [Symbol] = BOTTLE PALM
- [Symbol] = BANANA TREE
- [Symbol] = BANYAN TREE
- [Symbol] = BRAZILIAN PEPPER
- [Symbol] = CABBAGE TREE
- [Symbol] = COCONUT TREE
- [Symbol] = CLUSTER PALM
- [Symbol] = CYPRESS TREE
- [Symbol] = CANARY PALM
- [Symbol] = COCOS PLUMOSA
- [Symbol] = CACTUS
- [Symbol] = DATE PALM
- [Symbol] = FICUS TREE
- [Symbol] = FLORIDA ORCHID TREE
- [Symbol] = FOX TAIL TREE
- [Symbol] = GUMBO LIMBO TREE
- [Symbol] = HIBISCUS TREE
- [Symbol] = IXORA TREE
- [Symbol] = JUNIPER TREE
- [Symbol] = JARACANDA TREE
- [Symbol] = KAPOK TREE
- [Symbol] = LIVE OAK TREE
- [Symbol] = MAMEY TREE
- [Symbol] = MULBERRY TREE
- [Symbol] = MAHOGANY TREE
- [Symbol] = MANGO TREE
- [Symbol] = MANGROVE TREE
- [Symbol] = NISPERO TREE
- [Symbol] = NORFOLK TREE
- [Symbol] = OAK TREE
- [Symbol] = ORANGE GEIGER
- [Symbol] = PINE TREE
- [Symbol] = PALM TREE
- [Symbol] = PHILODENDRON/RUBBER TREE
- [Symbol] = QUEEN PALM TREE
- [Symbol] = RHOBOLINI TREE
- [Symbol] = ROYAL POINCIANA TREE
- [Symbol] = ROSEWOOD TREE
- [Symbol] = ROYAL PALM
- [Symbol] = SOUR ORANGE TREE
- [Symbol] = SEA GRAPE TREE
- [Symbol] = SOLITARY PALM
- [Symbol] = SILVER BUTTONWOOD TREE
- [Symbol] = TABEBULA TREE
- [Symbol] = TRAVELER CLUSTER
- [Symbol] = TAMARIND TREE
- [Symbol] = UNKNOWN TREE
- [Symbol] = UMBRELLA TREE
- [Symbol] = WASHINGTON PALM
- [Symbol] = ZAPODILLA TREE
- [Symbol] = HEDGES

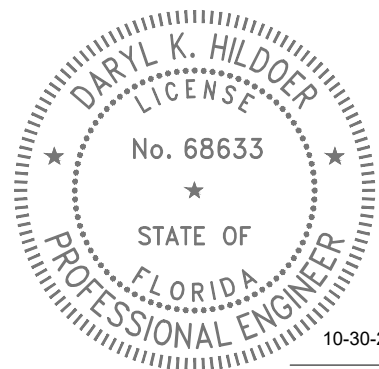

THIS ITEM HAS BEEN DIGITALLY SIGNED AND SEALED BY DARYL K. HILDOER, P.E. ON THE DATE ADJACENT TO THE SEAL.
 PRINTED COPIES OF THIS DOCUMENT ARE NOT CONSIDERED SIGNED AND SEALED AND THE SIGNATURE MUST BE VERIFIED ON ANY ELECTRONIC COPIES.

C:\Users\139108\AppData\Local\Temp\Temp\13928\Sht-3_SURVEYOR'S NOTES.dwg Sep 24, 2025 - 8:33am E139108

REVISIONS							
DATE	BY	DESCRIPTION	DATE	BY	DESCRIPTION	DATE	BY

RAINTREE LAKES
 NE 24 AVENUE AND NE 197 STREET AND
 NE 25 AVENUE FROM NE 200 STREET TO
 NE 202 STREET
 DRAINAGE IMPROVEMENT PROJECT

DESIGNED BY	NAME	DATE	DRAWN BY	NAME	DATE
	G.S.	8-22-25		H.S.	8-22-25
CHECKED BY	F.G.	8-22-25	CHECKED BY	G.S.	8-22-25



SURVEYOR'S NOTES, KEY SHEET
 LEGEND AND ABBREVIATIONS

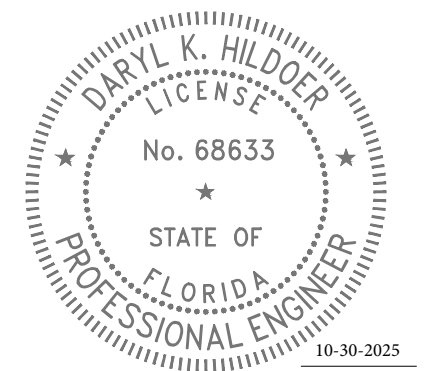
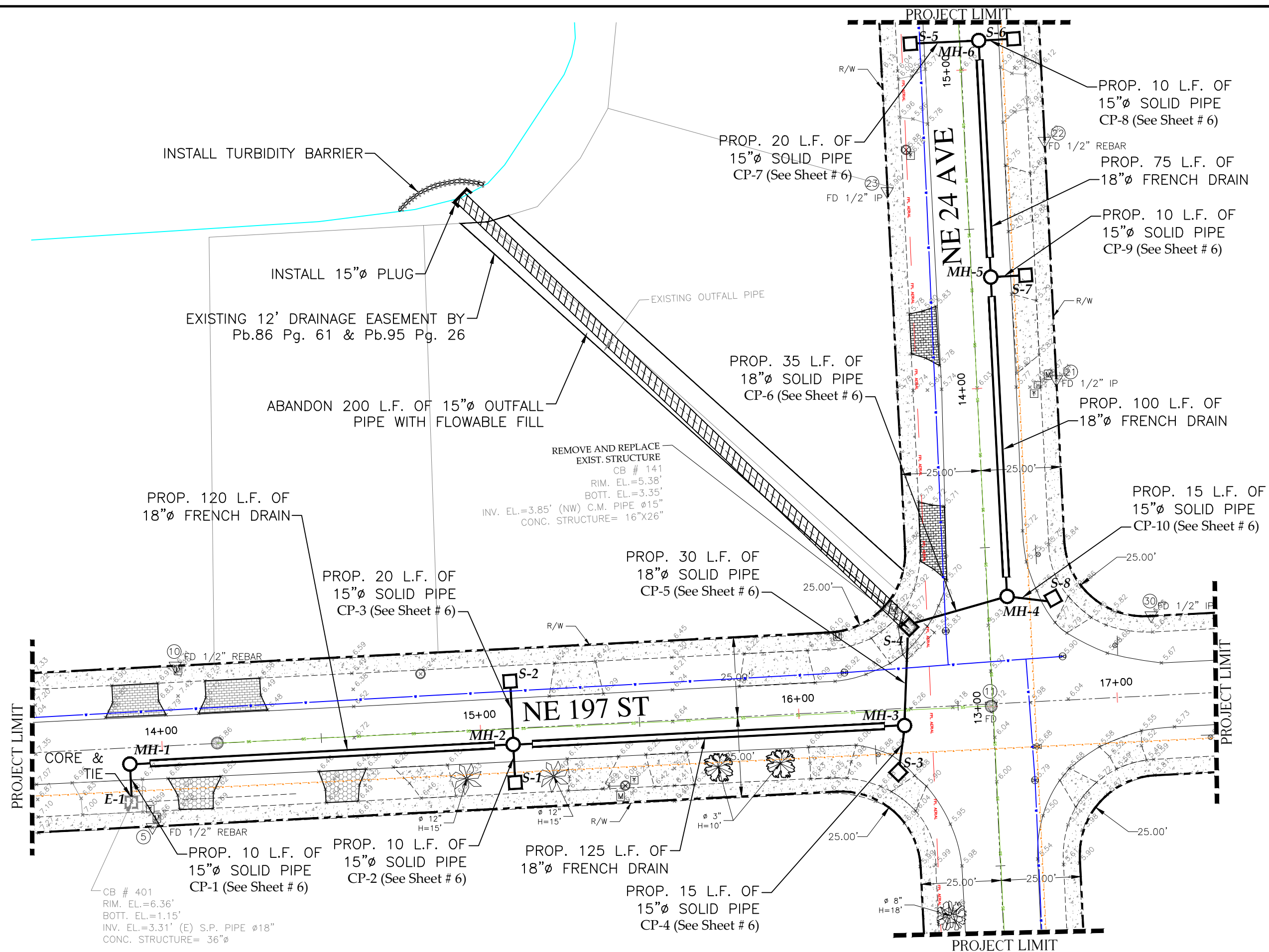

THIS ITEM HAS BEEN DIGITALLY SIGNED AND SEALED BY DARYL K. HILDOER, P.E. ON THE DATE ADJACENT TO THE SEAL.
PRINTED COPIES OF THIS DOCUMENT ARE NOT CONSIDERED SIGNED AND SEALED AND THE SIGNATURE MUST BE VERIFIED ON ANY ELECTRONIC COPIES.

C:\Users\el39108\AppData\Local\Temp\Temp\Pub\10924\SH-4_DRAINAGE IMPROVEMENT PROJECT NE 197 ST AND NE 24 AVE.dwg Oct 23, 2025 - 2:12pm E139108

REVISIONS								
DATE	BY	DESCRIPTION	DATE	BY	DESCRIPTION	DATE	BY	DESCRIPTION

NE 24 AVENUE AND NE 197 STREET
DRAINAGE IMPROVEMENT PROJECT

NAME	DATE	NAME	DATE
DESIGNED BY: G.S.	8-22-25	DRAWN BY: H.S.	8-22-25
CHECKED BY: D.H.	8-22-25	CHECKED BY: D.H.	8-22-25
SUPERVISED BY:			

MIAMI-DADE COUNTY
DEPARTMENT OF TRANSPORTATION AND PUBLIC WORKS
ROADWAY ENGINEERING AND RIGHT OF WAY DIVISION
STEPHEN P. CLARE CENTER
111 NW 1 ST
MIAMI, FLORIDA 33128

DRAINAGE PLAN

PROPOSED DRAINAGE STRUCTURE SCHEDULE										
Structure	Station	Type	Inside Dimensions	Rim Elevation	Bottom Elevation	Pipe Inverts				Remarks
						N	S	E	W	
S-1	15+09.67 (17.53 RT)	D-3	36"Ø	5.80	0.00	2.00				
S-2	15+09.19 (16.00 LT)	D-3	36"Ø	5.00	-1.08		0.92			
S-3	12+81.53 (30.82 LT)	D-3	36"Ø	5.40	0.25	2.25				
S-4	13+25.39 (25.71 LT)	P-10M	42"Ø	5.30	-3.00		1.60	-1.00		
S-5	15+09.98 (16.13 LT)	D-3	36"Ø	5.40	-1.82			0.18		
S-6	15+09.82 (16.68 RT)	D-3	36"Ø	5.30	-0.35				1.65	
S-7	14+34.40 (16.72 RT)	D-3	36"Ø	5.40	-0.35				1.65	
S-8	13+34.69 (20.28 RT)	D-3	36"Ø	5.40	0.40				2.40	
S-9	09+48.00 (13.00 LT)	D-3	36"Ø	4.50	-2.25		-0.25			
S-10	09+48.00 (15.00 RT)	D-3	36"Ø	4.70	-1.05	0.95				
S-11	10+55.00 (03.00 LT)	D-4	36"Ø	4.26	-1.06			0.94		
S-12	12+50.00 (15.00 LT)	D-3	36"Ø	4.70	-2.42				-0.42	
S-13	12+50.00 (15.00 RT)	D-3	36"Ø	4.70	-2.25				-0.25	
S-14	13+05.00 (14.00 RT)	D-3	36"x36"	4.90	-2.68	-0.10			-0.68	
S-15	13+64.00 (13.00 RT)	D-3	36"x36"	5.00	-2.25		-0.10		-0.25	
S-16	13+64.00 (18.00 LT)	D-3	36"Ø	5.00	-2.25			-0.25		
MH-1	13+89.59 (05.00 RT)	P-7T	42"Ø	5.60	-1.40	1.85	0.60			
MH-2	15+09.53 (05.14 RT)	P-7T	42"x42"	6.22	-1.40	0.92	2.00	1.22	0.60	
MH-3	12+95.48 (29.28 LT)	P-7T	42"Ø	6.22	-0.78	1.60	2.25		1.22	
MH-4	13+34.47 (06.03 RT)	P-7T	42"Ø	5.70	-3.00	0.70		2.40	-1.00	
MH-5	14+34.53 (06.04 RT)	P-7T	42"Ø	5.80	-1.30	0.80	0.70	1.65		
MH-6	15+09.82 (06.00 RT)	P-7T	42"Ø	6.20	-1.82		0.80	1.65	0.18	
MH-7	09+48.00 (05.00 LT)	P-7T	42"Ø	5.19	-2.25	-0.25	0.95	0.00		
MH-8	10+15.00 (05.00 LT)	P-7T	42"Ø	5.31	-2.00	1.20			0.00	
MH-9	12+50.00 (07.00 LT)	P-7T	42"Ø	5.20	-2.42	1.20	1.20	-0.25	-0.42	
MH-10	13+05.00 (05.00 LT)	P-7T	42"Ø	5.30	-2.68		1.20	-0.68		
E-1	13+89.51 (17.00 RT)	D-3	36"Ø	6.36	-0.15	1.85	Exist 3.31			Core & Tie To North Wall
E-2	10+55.00 (03.00 LT)		42"Ø	5.20		1.20	1.20			Core & Tie To South Wall

CONFLICT TABLE										
Conflict Point	Drainage		Gas		FPL		Water		Sanitary Sewer	
	Invert	Pipe Dia.	Top of Pipe	Pipe Dia.	Top of Pipe	Pipe Dia.	Top of Pipe	Pipe Dia.	Pipe Invert	Pipe Dia.
CP-1	1.85	15"	4.10 (A)	6"						
CP-2	2.00	15"	4.50 (A)	6"						
CP-3	3.30	15"					2.70 (A)	4"		
CP-4	2.25	15"	4.50 (A)	6"						
CP-5	1.60	15"					4.40 (A)	4"	-0.065 (A)	8"
CP-6	-0.75	15"			4.40 (A)	6" (A)	2.83 (A)	2"	1.10 (A)	8"
CP-7	0.18	15"					2.54 (A)	2"	2.03 (A)	8"
CP-8	1.65	15"	4.40	6"						
CP-9	1.65	15"	4.20	6"						
CP-10	2.40	15"	4.26	6"						
CP-11	-0.25	15"					2.50 (A)	6"		
CP-12	1.20	18"			2.55 (A)	6" (A)				
CP-13	-0.42	15"					-0.42 (A)	6"		
CP-14	-0.25	15"							1.49 (A)	8"
CP-15	-0.68	18"							1.32 (A)	8"
CP-16	-0.25	15"					2.00 (A)	6"	1.07 (A)	8"

All utility inverts and or/ size that are not provided by the utility Company will be assumed by the Engineer for design purposes. Assumed inverts and/ or size will be followed by an "A" and standard cover for that utility will be applied. The contractor is advised that the Engineer is providing the most accurate information available, and that the contractor must always use due care while excavating around conflicts. The contractor is still responsible for verifying all utilities prior to excavating. All depths on table are in NVGD.

SUMMARY OF QUANTITIES			
Item No.	Description	Unit	Quantity
102-74-1	Barricades (Temporary - Types I, II, VP and Drum)	EA./DAY	7200
102-74-2	Barricades (Temporary, Type III, 6')	E.A./day	360
102-76A	Advanced Warning Arrow Panel	EA./DAY	120
104-10-3	Sediment Barrier	L.F.	200
104-11A	Floating Turbidity Barrier	L.F.	40
104-18	Inlet Protection System	EA.	17
121-70-2	Flowable Fill	C.Y.	520
327-7-01	Milling Existing Pavement - [(1" Depth) (Up to 5,000 S.Y.)]	S.Y.	400
331-72-10A-HMA	Roadway Pavement Restoration (Replace and match existing base thickness and asphalt course with 8" minimum, primed Limerock Base and 1" thick of HMA, Asphalt Work Category 3)	S.Y.	471
331-72-10B-HMA	Inlet Pavement (Includes 6" Limerock Base and 1" thick of HMA, Asphalt Work Category 2)	S.Y.	167
334-2-13-1	Hot Mix Asphalt, Traffic C, SP-9.5	TON	50
334-2-13-1A	Driveway Pavement - Asphalt	S.Y.	10
350-1-1A	Driveway Pavement - Concrete	S.Y.	10
400-1-15	Class I Concrete (Miscellaneous) (Trench build-up, collars, pipe plugs, structure plugs etc.) (This item is contingent upon field conditions and may increased decreased or eliminated by the Engineer)	C.Y.	5
425-1-1	Swale Inlet Type D-3 (36" Dia.) (Less than 10 feet deep)	EA.	16
425-2-41	Manhole (Type P-7T, Any dimension, maximum 15' deep)	EA.	10
425-79	Core and Tie to exist. drainage structures. (Any pipe size hole opening) (Including mortar seal) (This item is contingent upon field conditions and may increased decreased or eliminated by the Engineer)	E.A.	2
425-82	Modify Structure-Cut to enlarge opening as needed in order to accommodate pipe due to utility conflict(s), brick and mortar as needed	EA.	5
430-94-1-1	Desilting Pipe, 0 - 48"	L.F.	155
430-95-2	Desilting Drainage Structure	E.A.	4
430-171-115	Pipe Culvert - 15" Diameter (Round)	L.F.	110
430-171-118	Pipe Culvert - 18" Diameter (Round)	L.F.	110
443-70-3-2	French Drain (18" diameter pipe, trench depth 10 ft bls)	L.F.	680
522-1(1)	Concrete Sidewalk (4" thick)(3000 P.S.I.)(Including pedestrian ramps and sidewalk curbs)	S.Y.	167
575-2A	Sodding - St. Augustine, or match existing, includes watering and maintenance. Contingent item based on field conditions, may be increased, or decreased by the engineer	S.Y.	300
706-1-12	Reflective Pavement Markers (class B, mono or bi-directional, all colors)	EA.	8
711-11-125	Thermoplastic (White) (Solid) (24")	L.F.	20
711-11-221	Thermoplastic (Yellow) (Solid) (6")	L.F.	100

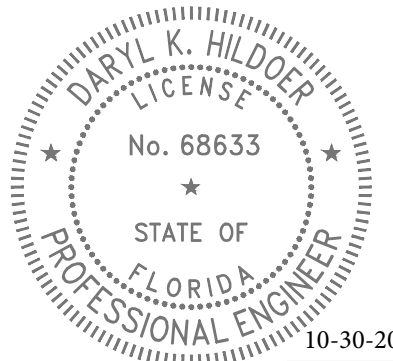

THIS ITEM HAS BEEN DIGITALLY SIGNED AND SEALED BY DARYL K. HILDOER, P.E. ON THE DATE ADJACENT TO THE SEAL.
PRINTED COPIES OF THIS DOCUMENT ARE NOT CONSIDERED SIGNED AND SEALED AND THE SIGNATURE MUST BE VERIFIED ON ANY ELECTRONIC COPIES.

C:\Users\el139108\AppData\Local\Temp\Pub\10924\Sht-6 SUMMARY OF QUANTITIES.dwg Oct 23, 2025 - 2:10pm E139108

REVISIONS							
DATE	BY	DESCRIPTION	DATE	BY	DESCRIPTION	DATE	BY

RAINTREE LAKES
NE 24 AVENUE AND NE 197 STREET AND
NE 25 AVENUE FROM
NE 200 STREET TO NE 202 STREET
DRAINAGE IMPROVEMENT PROJECT

NAME	DATE	NAME	DATE
DESIGNED BY: G.S.	8-22-25	DRAWN BY: H.S.	8-22-25
CHECKED BY: F.G.	8-22-25	CHECKED BY: G.S.	8-22-25
SUPERVISED BY:			

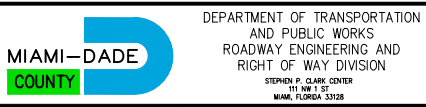

PROPOSED DRAINAGE STRUCTURES TABLE, CONFLICT TABLE AND SUMMARY OF QUANTITIES

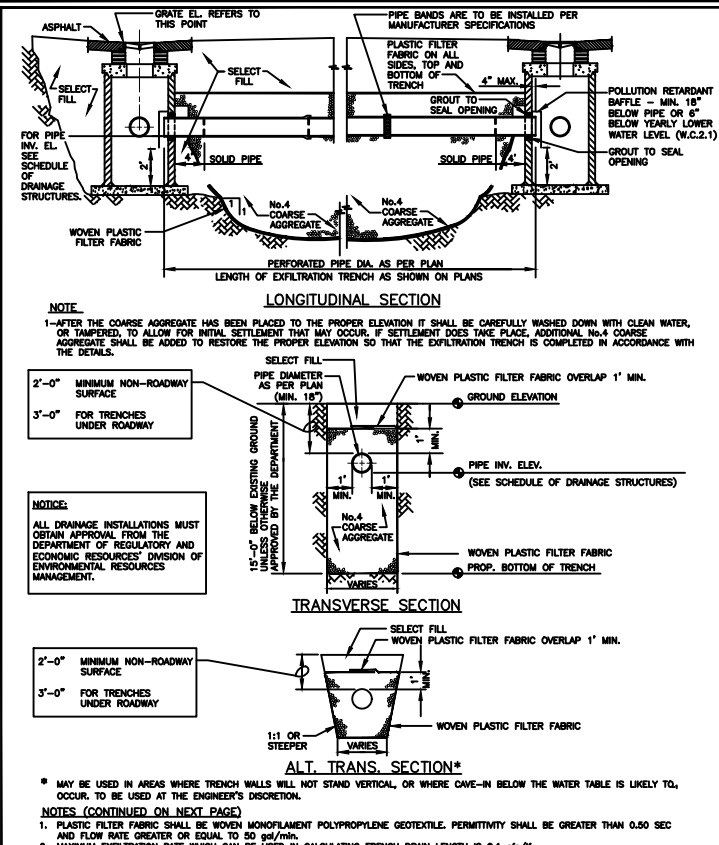

MIAMI-DADE COUNTY	APPROVED 09/18/2019	REVISED 09/26/2012 10/19/2012 09/18/2019	STANDARD STORM DRAINAGE DETAIL EXFILTRATION TRENCH (FRENCH DRAIN)	SD 1.1
-------------------	------------------------	---	---	-----------

NOTES CONTINUED

- THE MINIMUM PIPE DIAMETER FOR DRAINAGE SYSTEM WITHIN THE ROADWAY RIGHT-OF-WAY SHALL BE 18 INCHES. 15 INCH PIPE MAY BE USED IN PRIVATE ROADWAYS.
- NO TREES TO BE PLANTED WITHIN 5 FEET OF THE EDGE OF THE TRENCH.
- TYPE "P" S.D. 2.8 STRUCTURE IS RECOMMENDED FOR SMALL DRAINAGE AREAS LESS THAN 0.2 ACRE PER CATCH BASIN.
- TYPE "I" S.D. 2.8 STRUCTURE IS RECOMMENDED FOR AREAS LARGER THAN 0.2 ACRE.
- ALL INVERTS OF PERFORATED PIPES TO BE AT MEAN HIGH OCTOBER WATER TABLE W.C. 2.2.
- PIPES CAN BE ALLOWED BELOW MEAN HIGH OCTOBER WATER TABLE DUE TO UTILITY CONFLICTS OR IN ORDER TO PROVIDE THE REQUIRED MINIMUM COVER.
- NEOPRENE GASKET REQUIRED FOR BAFFLES ON ALL CONTACT EDGES MOUNTED ON WALL.
- OIL AND GREASE BAFFLE IS REQUIRED FOR ALL DRAINAGE STRUCTURES PRECEDING AN OUTFALL OR EXFILTRATION TRENCHES, IN PROJECTS LOCATED IN WETLAND PROTECTION AREAS, ROAD INTERSECTIONS WITH TRAFFIC LIGHTS, AND LARGE PARKING LOTS WHICH INCLUDE 15 PARKING SPACES OR MORE.
- OIL AND GREASE BAFFLE MAY BE WAIVED IN SUBURBAN RESIDENTIAL AREAS.

GENERAL NOTES FOR PIPE CULVERTS

CONTRACTOR HAS THE OPTION OF INSTALLING ANY PIPE MEETING THE REQUIREMENTS OF SECTION 443-2 OF THE FDOT STANDARD SPECIFICATIONS FOR ROAD AND BRIDGE CONSTRUCTION AS LONG AS THE MANUFACTURER IS LISTED, AT THE TIME OF PIPE INSTALLATION, IN FDOT'S LIST OF PRODUCERS WITH ACCEPTED QUALITY CONTROL PROGRAMS. PIPES WITH LESS THAN A 100-YEAR CERTIFICATION CANNOT BE USED ON SECTION LINE, HALF SECTION LINE, COLLECTOR ROADWAYS, AND ARTERIALS. 50-YEAR PIPE CERTIFICATION REQUIRED FOR ALL OTHER MINOR/LOCAL ROADWAYS.

PIPE DIAMETER (inches)	OUTER SHELL		LINER	
	No. of 3/8" Dia. Holes (PER LIN. FT. OF PIPE)	No. of 5/8" Dia. Holes (PER LIN. FT. OF PIPE)	No. of 3/8" Dia. Holes (PER LIN. FT. OF PIPE)	No. of 5/8" Dia. Holes (PER LIN. FT. OF PIPE)
15	100	50		
18	120	60		
24	160	80		
30	200	100		
36	240	120		
42	275	140		
48	315	150		
54	355	180		
60	395	200		
72	470	235		
84	550	275		

NOTE:
PERFORATIONS SHALL BE UNIFORMLY SPACED AROUND THE FULL PERIPHERY OF THE PIPE TO WITHIN 4" OF EACH END OF EACH LENGTH OF PIPE. THE NUMBER OF PERFORATIONS PER LINEAR FOOT OF PIPE AND THE DIAMETER OF THE PERFORATIONS SHALL BE AS SHOWN ON THE ABOVE TABLE.

MIAMI-DADE COUNTY	APPROVED 04/18/2018	REVISED 08-01-06 10-22-13 08-02-81	STANDARD STORM DRAINAGE DETAIL EXFILTRATION TRENCH (PIPE CULVERT NOTES)	SD 1.1
-------------------	------------------------	---	---	-----------

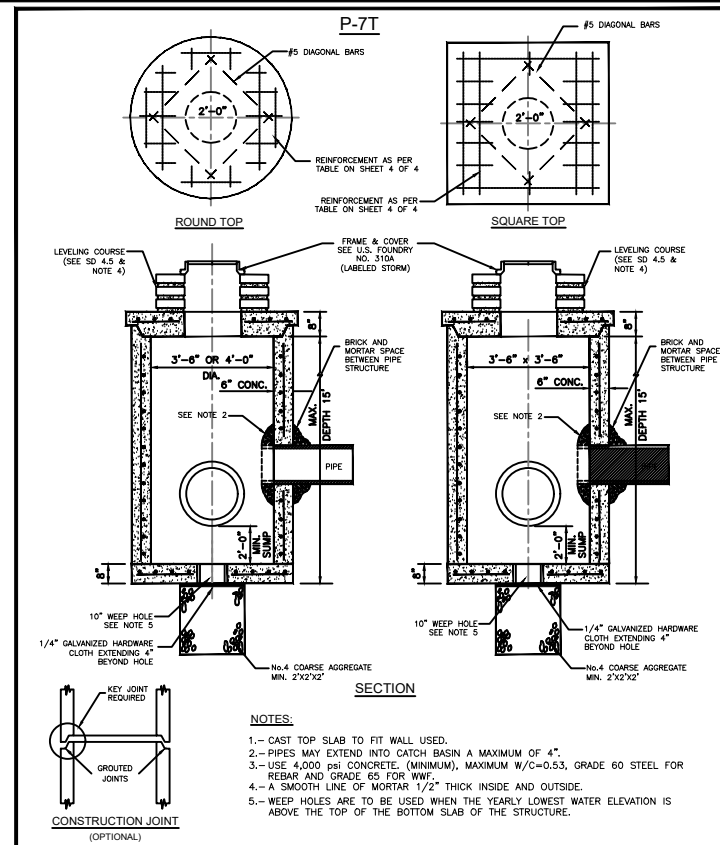

MIAMI-DADE COUNTY	APPROVED 5/9/2018	REVISED 6/9/2018	STANDARD STORM DRAINAGE DETAIL MANHOLE AND INLET (TYPE P)	SD 2.7
-------------------	----------------------	---------------------	---	-----------

Standard Detail	Width (ft)	Length (ft)	Height (ft)	Wall Thickness (in)	Wall Steel	Top Slab Thickness (in)	Top Slab Steel	Bottom Slab Thickness (in)	Bottom Slab Steel
2.7	3.5	3.5	0.0 - 5.0	6.0	#4@10"H #4@10"V	8.0	#4@7" E.W.	8.0	#4@10" E.W.
2.7	3.5	3.5	5.1 - 10.0	6.0	#4@9"H #4@10"V	8.0	#4@6" E.W.	8.0	#4@10" E.W.
2.7	3.5	3.5	10.1 - 15.0	6.0	#5@6"H #4@10"V	8.0	#4@6.5" E.W.	8.0	#4@10" E.W.

Standard Detail	Dia. (ft) Min.	Dia. (ft) Max.	Height (ft)	Wall Thickness (in)	Wall Steel	Top Slab Thickness (in)	Top Slab Steel	Bottom Slab Thickness (in)	Bottom Slab Steel
2.7	3.5	4.0	0.0 - 5.0	6.0	8 x 8 W20 or #4@10"E.W.	8.0	#4@7" E.W.	8.0	#4@10" E.W.
2.7	3.5	4.0	5.1 - 10.0	6.0	8 x 8 W20 or #4@10"E.W.	8.0	#4@6" E.W.	8.0	#4@10" E.W.
2.7	3.5	4.0	10.1 - 15.0	6.0	8 x 8 W20 or #4@10"E.W.	8.0	#4@6.5" E.W.	8.0	#4@10" E.W.

MIAMI-DADE COUNTY	APPROVED 5/9/2018	REVISED 6/9/2018	STANDARD STORM DRAINAGE DETAIL MANHOLE AND INLET (TYPE P)	SD 2.7
-------------------	----------------------	---------------------	---	-----------

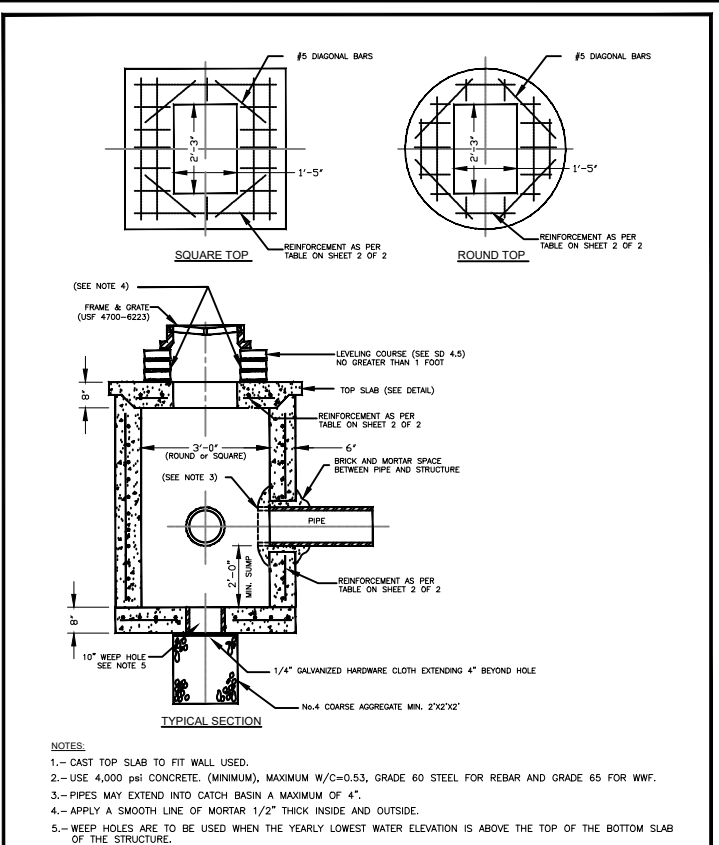

MIAMI-DADE COUNTY	APPROVED 5/9/2018	REVISED 6/9/2018 9/16/2013 9/26/2012 2/9/2011 3/7/1991	STANDARD STORM DRAINAGE DETAIL PRECAST CATCH BASIN (D-3)	SD 2.2
-------------------	----------------------	---	--	-----------

Standard Detail	Width (ft)	Length (ft)	Height (ft)	Wall Thickness (in)	Wall Steel	Top Slab Thickness (in)	Top Slab Steel	Bottom Slab Thickness (in)	Bottom Slab Steel
2.2	3	3	0.0 - 5.0	6	#4@10"H #4@10"V	8	#4@5" E.W.	8	#4@10" E.W.
2.2	3	3	5.1 - 10.0	6	#4@7.5"H #4@10"V	8	#4@5" E.W.	8	#4@10" E.W.
2.2	3	3	10.1 - 15.0	6	#5@7.5"H #4@10"V	8	#4@5" E.W.	8	#4@10" E.W.

Standard Detail	Dia. (ft)	Height (ft)	Wall Thickness (in)	Wall Steel	Top Slab Thickness (in)	Top Slab Steel	Bottom Slab Thickness (in)	Bottom Slab Steel
2.2	3	0.0 - 5.0	6	8 x 8 W20 #4@10"E.W.	8	#4@5" E.W.	8	#4@10" E.W.
2.2	3	5.1 - 15.0	6	8 x 8 W20 #4@10"E.W.	8	#4@5" E.W.	8	#4@10" E.W.

MIAMI-DADE COUNTY	APPROVED 5/9/2018	REVISED 6/9/2018	STANDARD STORM DRAINAGE DETAIL PRECAST CATH BASIN (TYPE D-3)	SD 2.2
-------------------	----------------------	---------------------	--	-----------

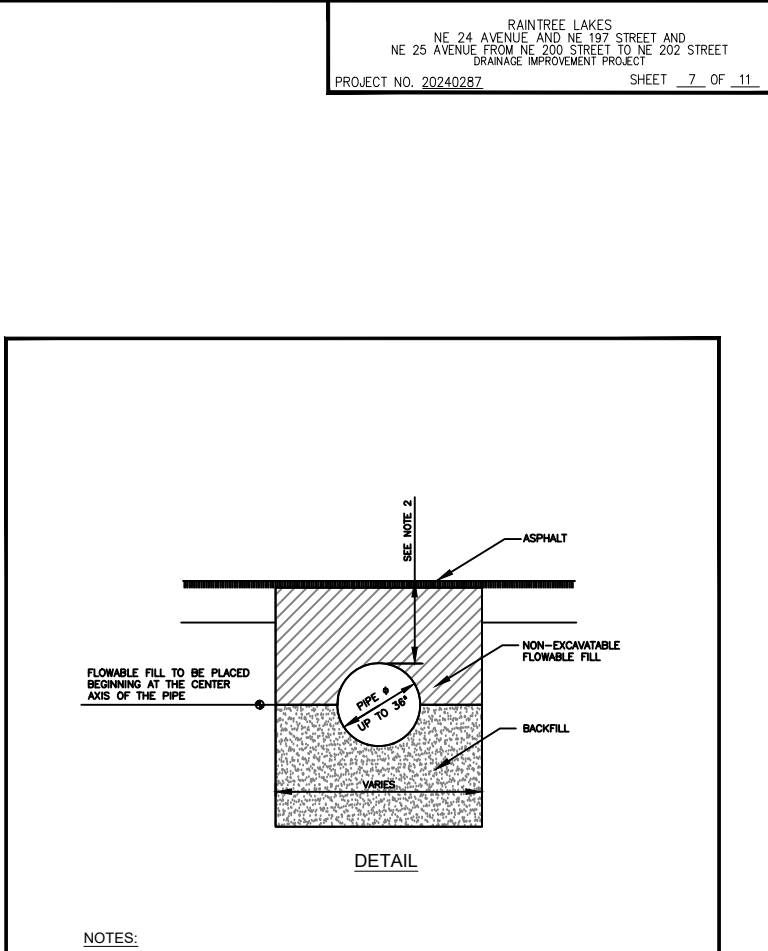

MIAMI-DADE COUNTY	APPROVED	REVISED 9-27-12	STANDARD STORM DRAINAGE DETAIL NON-EXCAVATABLE FLOWABLE FILL DETAIL	SD 0.0
-------------------	----------	--------------------	---	-----------

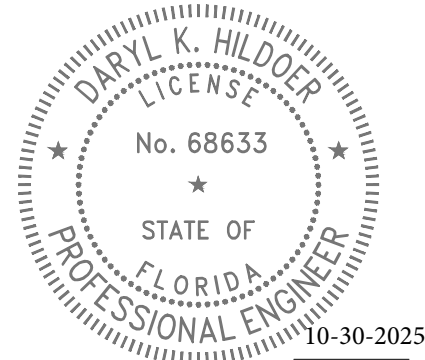

THIS ITEM HAS BEEN DIGITALLY SIGNED AND SEALED BY DARYL K. HILDOER, P.E. ON THE DATE ADJACENT TO THE SEAL.

PRINTED COPIES OF THIS DOCUMENT ARE NOT CONSIDERED SIGNED AND SEALED AND THE SIGNATURE MUST BE VERIFIED ON ANY ELECTRONIC COPIES.

S:\Vector\George Sibilia\2025\NE 24 AVE AND NE 197 ST & NE 25 AVE FROM NE 200 ST TO NE 202 ST\20240287\RAINAGE IMPROVEMENT PROJECT\SH-7 STANDARD DETAILS.dwg Sep 24, 2025 - 8:36am E:139108

REVISIONS					
DATE	BY	DESCRIPTION	DATE	BY	DESCRIPTION

RAINTREE LAKES
NE 24 AVENUE AND NE 197 STREET AND
NE 25 AVENUE FROM
NE 200 STREET TO NE 202 STREET
DRAINAGE IMPROVEMENT PROJECT

NAME	DATE	NAME	DATE
DESIGNED BY: G.S.	8-22-25	DRAWN BY: H.S.	8-22-25
CHECKED BY: F.G.	8-22-25	CHECKED BY: G.S.	8-22-25
SUPERVISED BY:			



DEPARTMENT OF TRANSPORTATION AND PUBLIC WORKS
ROADWAY ENGINEERING AND RIGHT OF WAY DIVISION
STEPHEN F. CLARK CENTER
MIAMI, FLORIDA 33128

STANDARD DETAILS

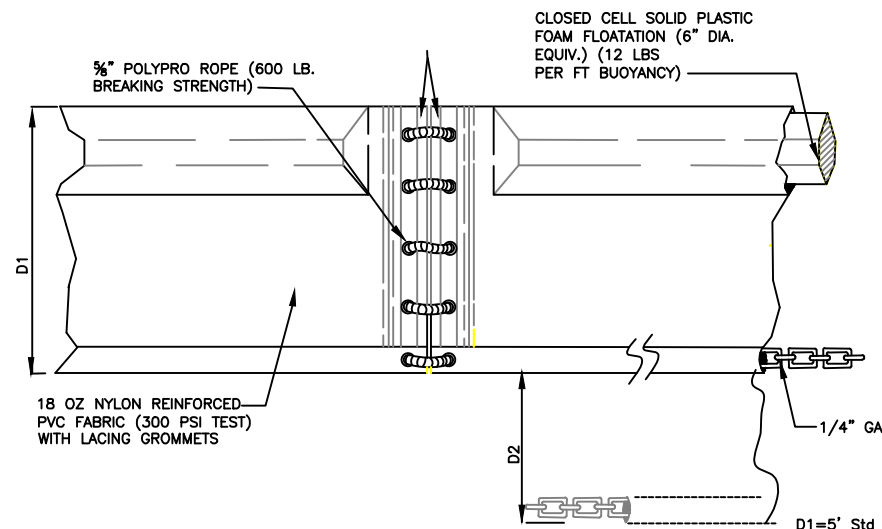

TYPE I

D1=5' Std (Single Panel For Depths 5' or less).
D2=5' Std. (Additional Panel For Depths >5').
Curtain To Reach bottom Up To Depths of 10 Feet.
Two (2) Panels to be used for depths greater than
10' unless special depth curtains are specifically
called for in the plans or as determined by the
Engineer.

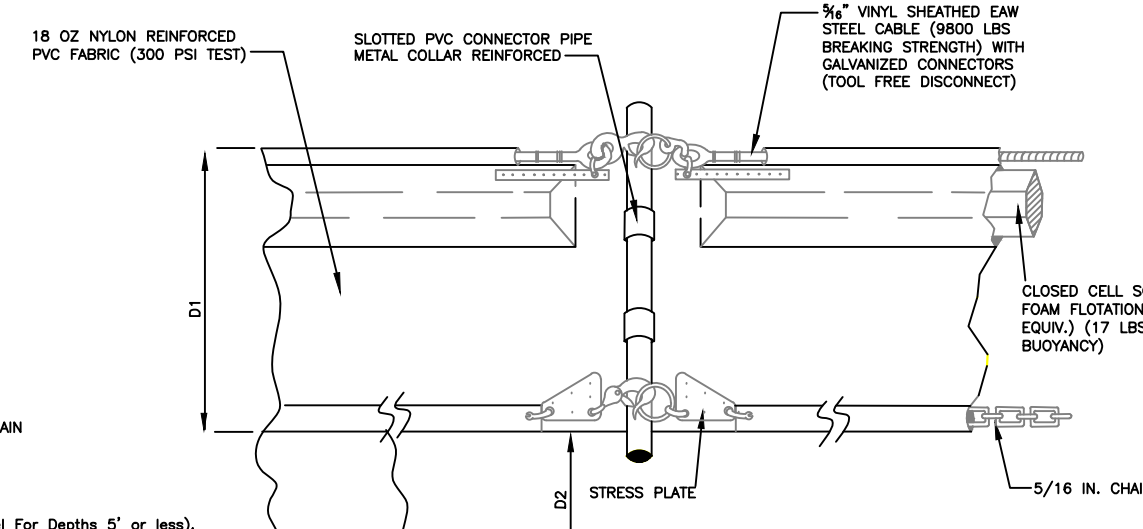

TYPE II

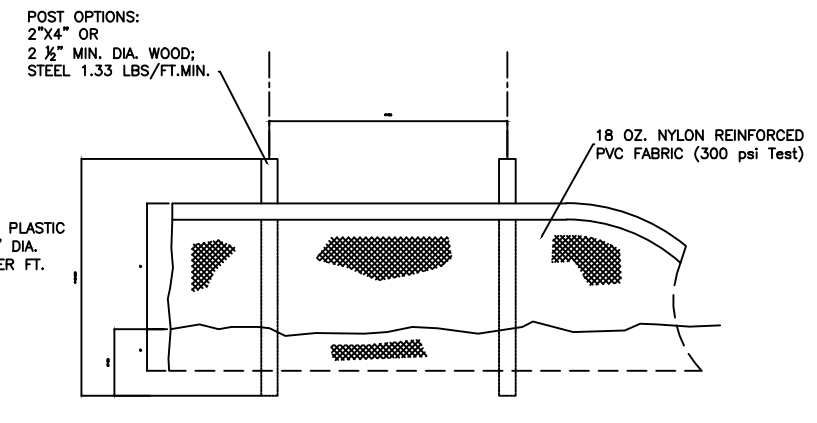

STAKED TURBIDITY BARRIER (TYP.)

LEGEND:

- PILE LOCATIONS
- ▨ DREDGE OR FILL AREA
- MOORING BUOY W/ANCHOR
- ANCHOR
- BARRIER MOVEMENT DUE TO CURRENT ACTION

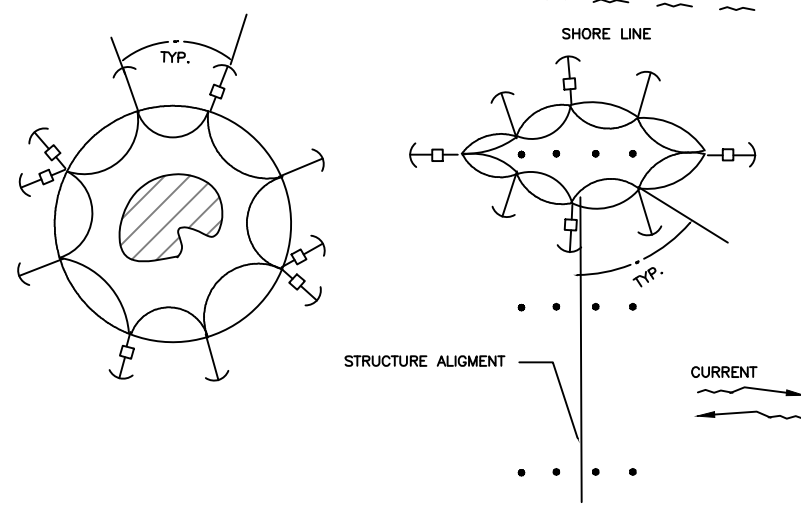
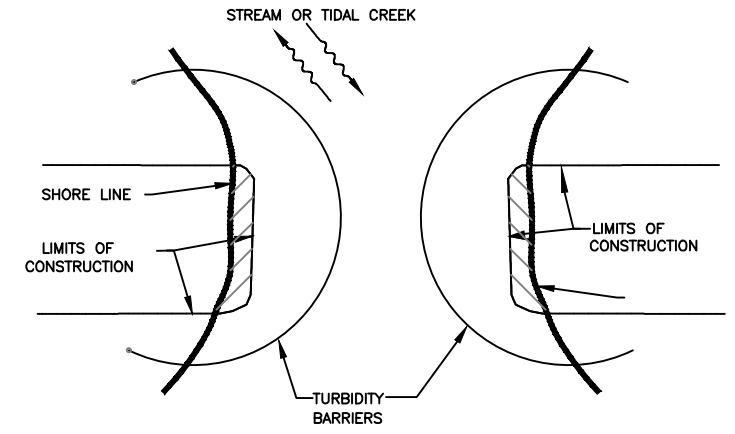
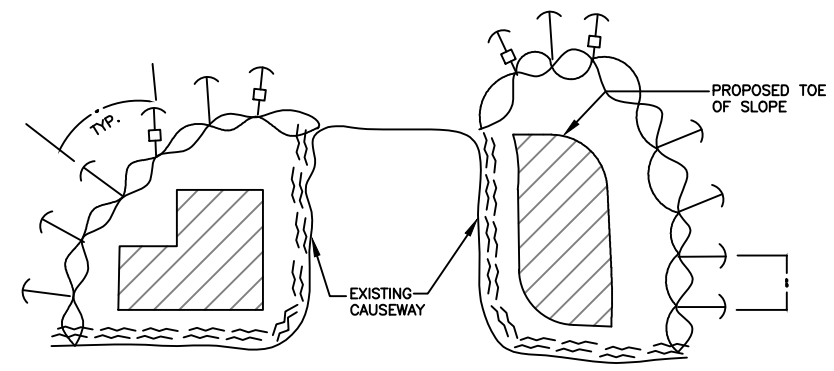

NOTE:

TURBIDITY BARRIERS FOR FLOWING STREAMS AND TIDAL CREEKS MAY BE EITHER FLOATING, OR STAKED TYPES OR ANY COMBINATIONS OF TYPES THAT WILL SUIT SITE CONDITIONS AND MEET EROSION CONTROL AND WATER QUALITY REQUIREMENTS. THE BARRIER TYPE(S) WILL BE AT THE CONTRACTOR'S OPTION UNLESS OTHERWISE SPECIFIED IN THE PLANS, HOWEVER PAYMENT WILL BE UNDER THE PAY ITEMS(S) ESTABLISHED IN THE PLANS FOR FLOATING TURBIDITY BARRIER AND/OR STAKED TURBIDITY BARRIER. POSTS IN STAKED TURBIDITY BARRIERS IS TO BE INSTALLED IN VERTICAL POSITION UNLESS OTHERWISE DIRECTED BY THE ENGINEER.

NOTES:

- 1- TURBIDITY BARRIERS ARE TO BE USED IN ALL PERMANENT BODIES OF WATER REGARDLESS OF WATER DEPTH.
- 2- NUMBER AND SPACING OF ANCHORS DEPENDENT ON CURRENT VELOCITIES.
- 3- DEPLOYMENT OF BARRIER AROUND PILE LOCATIONS MAY VARY TO ACCOMMODATE CONSTRUCTION OPERATIONS.
- 4- NAVIGATION MAY REQUIRE SEGMENTING BARRIER DURING CONSTRUCTION OPERATIONS.

**TURBIDITY BARRIER APPLICATIONS
FLOATING TURBIDITY BARRIERS (TYP.)**

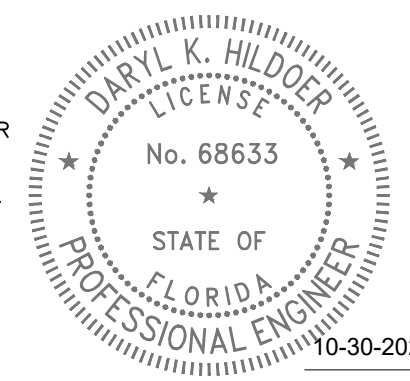

10-30-2025

THIS ITEM HAS BEEN DIGITALLY SIGNED AND SEALED BY DARYL K. HILDOER, P.E. ON THE DATE ADJACENT TO THE SEAL.

PRINTED COPIES OF THIS DOCUMENT ARE NOT CONSIDERED SIGNED AND SEALED AND THE SIGNATURE MUST BE VERIFIED ON ANY ELECTRONIC COPIES.

S:\Hector\George_Shibilia\2025\NE 24 AVE AND NE 197 ST & NE 25 AVE FROM NE 200 ST TO NE 202 ST TO NE 202 STREET DRAINAGE IMPROVEMENT PROJECT\SH-8 TURBIDITY BARRIER.dwg Sep 24, 2025 - 4:17pm E139108

REVISIONS

DATE	BY	DESCRIPTION	DATE	BY	DESCRIPTION

RAINTREE LAKES
NE 24 AVENUE AND NE 197 STREET AND
NE 25 AVENUE FROM
NE 200 STREET TO NE 202 STREET
DRAINAGE IMPROVEMENT PROJECT

DESIGNED BY	NAME	DATE	DRAWN BY	NAME	DATE
G.S.	G.S.	8-22-25	H.S.	H.S.	8-22-25
CHECKED BY	F.G.	8-22-25	CHECKED BY	G.S.	8-22-25
SUPERVISED BY					



DEPARTMENT OF TRANSPORTATION
AND PUBLIC WORKS
ROADWAY ENGINEERING AND
RIGHT OF WAY DIVISION
STEPHEN P. CLARKE, CENTER
111 NE 1 ST.
MIAMI, FLORIDA 33128

TURBIDITY BARRIER APPLICATIONS
FLOATING TURBIDITY BARRIERS (TYP.)

POST OPTIONS:
SOFTWOOD 2 3/4" DIA.
SOFTWOOD 2"x4"
HARDWOOD 1 1/2" x 1 1/2"
STEEL 1.33 lbs/FT

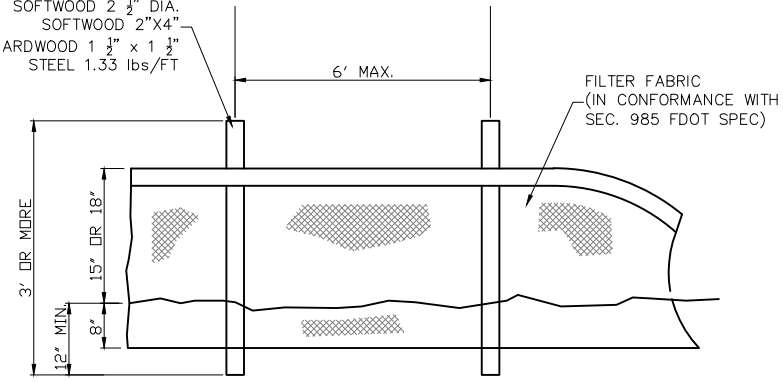

ELEVATION

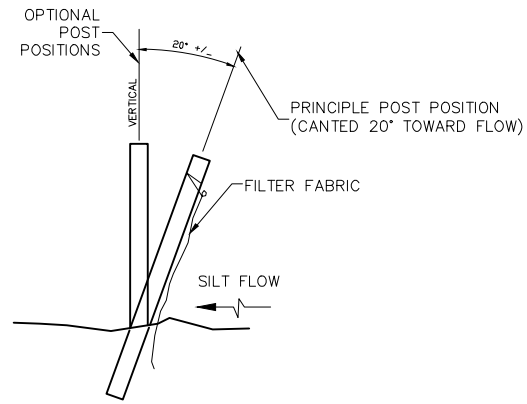

SECTION

TYPE III SILT FENCE (TYP.)

POST OPTIONS:
SOFTWOOD 4" DIA.
SOFTWOOD 4"x4"
HARDWOOD 3" DIA.
STEEL 1.33 lbs/FT MIN.

POULTRY MESH (20 GA. MIN.)
OR TYPE A FENCE FABRIC
(INDEX No. 801 &
SECTION 550 FDOT SPEC.)

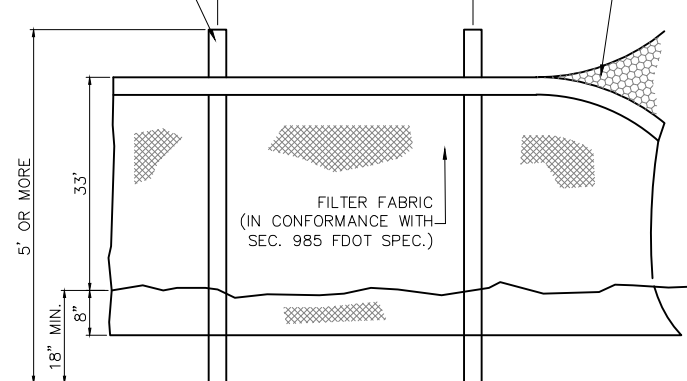

ELEVATION

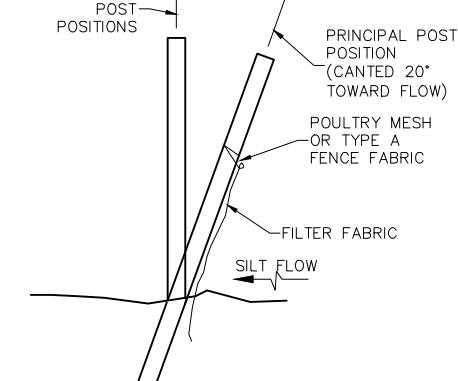

SECTION

TYPE IV SILT FENCE (TYP.)

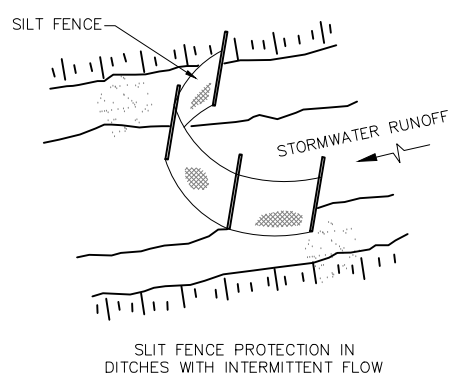
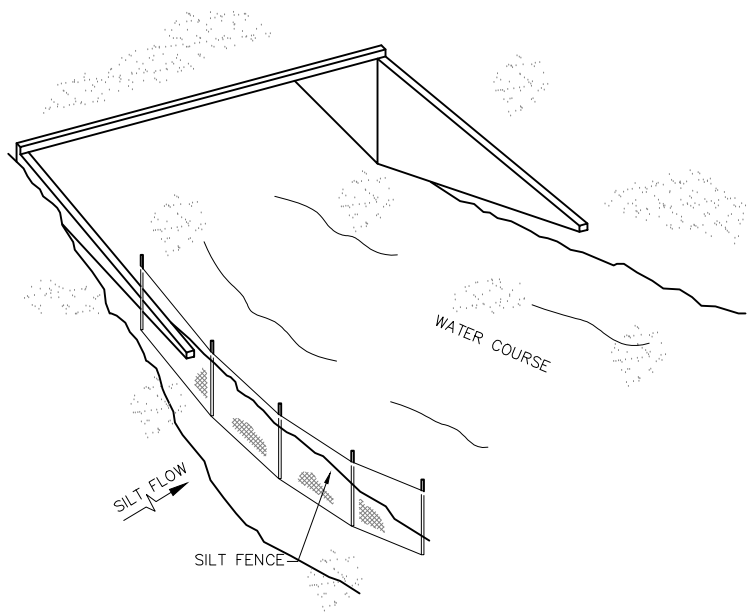

SILT FENCE PROTECTION IN DITCHES WITH INTERMITTENT FLOW

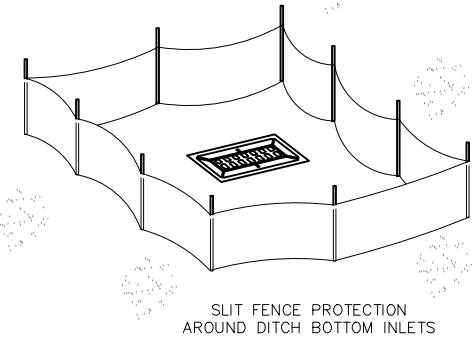

SILT FENCE PROTECTION AROUND DITCH BOTTOM INLETS

SILT FENCE APPLICATIONS (TYP.)

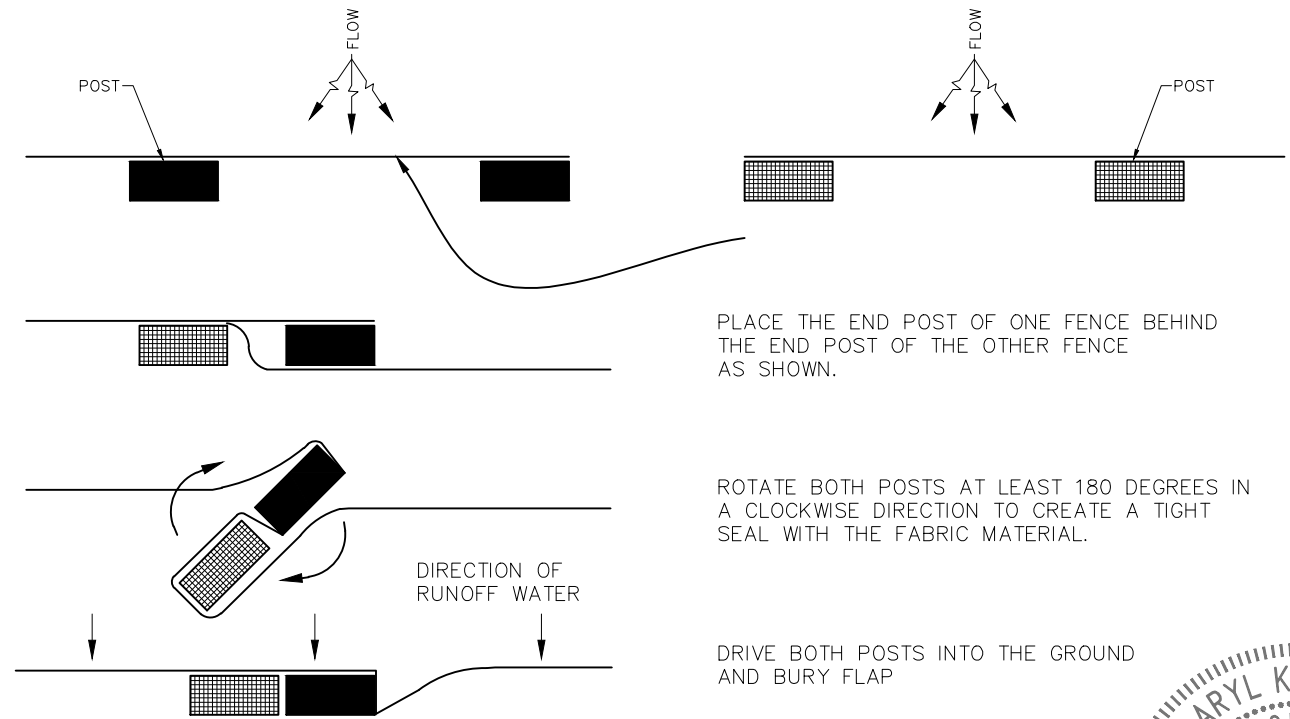

PLANT VIEW

JOINING TWO SILT FENCES (TYP.)

PLACE THE END POST OF ONE FENCE BEHIND THE END POST OF THE OTHER FENCE AS SHOWN.

ROTATE BOTH POSTS AT LEAST 180 DEGREES IN A CLOCKWISE DIRECTION TO CREATE A TIGHT SEAL WITH THE FABRIC MATERIAL.

DRIVE BOTH POSTS INTO THE GROUND AND BURY FLAP

NOTES FOR SILT FENCES:

- 1- TYPE III SILT FENCE TO BE USED AT MOST LOCATIONS. WHERE USED IN DITCHES, THE SPACING FOR TYPE III SILT FENCE SHALL BE IN ACCORDANCE WITH CHART 1, SHEET 1 OF 2010 FDOT DESIGN STANDARDS INDEX 102.
- 2- TYPE IV SILT FENCE TO BE USED WHERE LARGE SEDIMENT LOADS ARE ANTICIPATED. SUGGESTED USE IS WHERE FILL SLOPE IS 1:2 OR STEEPER AND LENGTH OF SLOPE EXCEEDS 25 FEET. AVOID USE WHERE THE DETAINED WATER MAY BACK INTO TRAVEL LANES OR OFF THE RIGHT OF WAY.

- 3- DO NOT CONSTRUCT SILT FENCES ACROSS PERMANENT FLOWING WATERCOURSES. SILT FENCES ARE TO BE AT UPLAND LOCATIONS AND TURBIDITY BARRIERS USED AT PERMANENT BODIES OF WATER.
- 4- WHERE USED AS SLOPE PROTECTION, SILT FENCE IS TO BE CONSTRUCTED ON 0% LONGITUDINAL GRADE TO AVOID CHANNELIZING RUNOFF ALONG THE LENGTH OF THE FENCE.

SEDIMENT BARRIERS (TYP.)
OR APPROVED ALTERNATIVE

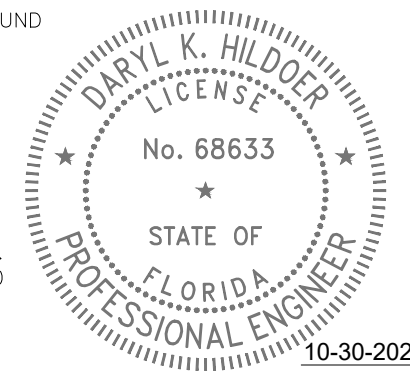

THIS ITEM HAS BEEN DIGITALLY SIGNED AND SEALED BY DARYL K. HILDOER, P.E. ON THE DATE ADJACENT TO THE SEAL.

PRINTED COPIES OF THIS DOCUMENT ARE NOT CONSIDERED SIGNED AND SEALED AND THE SIGNATURE MUST BE VERIFIED ON ANY ELECTRONIC COPIES.

S:\Hector\George_Sibilia\2025\NE 24 AVE AND NE 197 ST & NE 25 AVE FROM NE 200 ST TO NE 202 ST\20240287\DRAINAGE IMPROVEMENT PROJECT\SH-9 SEDIMENT BARRIER.dwg Sep. 24, 2025 - 8:37am E139108

REVISIONS								
DATE	BY	DESCRIPTION	DATE	BY	DESCRIPTION	DATE	BY	DESCRIPTION

RAINTREE LAKES
NE 24 AVENUE AND NE 197 STREET AND
NE 25 AVENUE FROM
NE 200 STREET TO NE 202 STREET
DRAINAGE IMPROVEMENT PROJECT

DESIGNED BY	NAME	DATE	DRAWN BY	NAME	DATE
G.S.	G.S.	8-22-25	H.S.	H.S.	8-22-25
CHECKED BY	F.G.	8-22-25	CHECKED BY	G.S.	8-22-25
SUPERVISED BY:					

DEPARTMENT OF TRANSPORTATION AND PUBLIC WORKS
ROADWAY ENGINEERING AND RIGHT OF WAY DIVISION
STEPHEN P. CLARK CENTER
111 NW 115 ST
MIAMI, FLORIDA 33128

SEDIMENT BARRIERS DETAILS

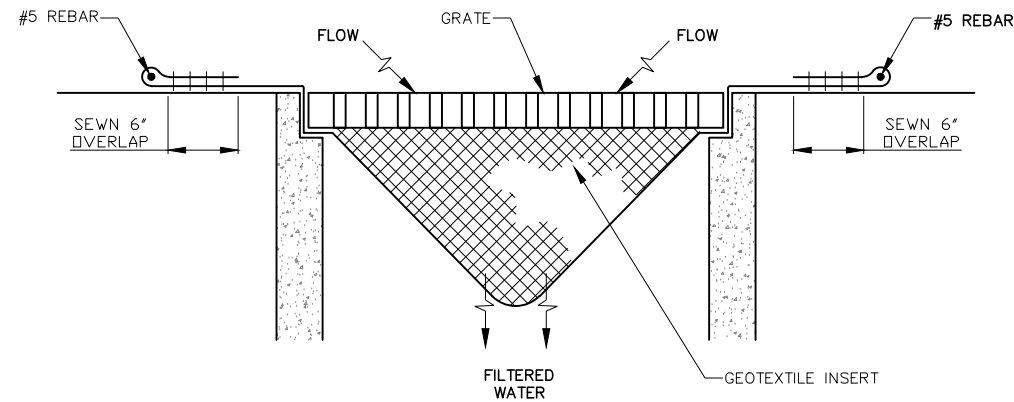

PREFABRICATED FILTER INSERT - TYPE 1
NOT TO SCALE

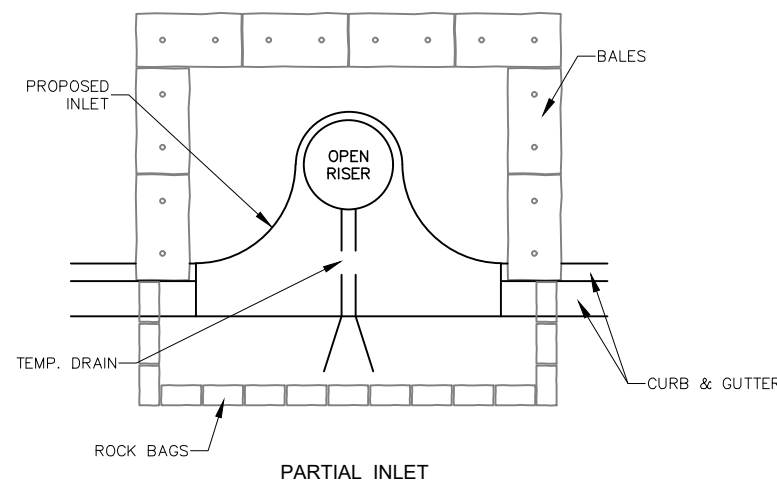

PARTIAL INLET

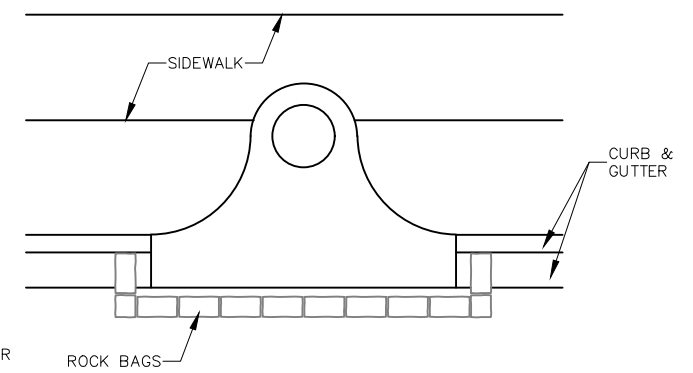

COMPLETED INLET

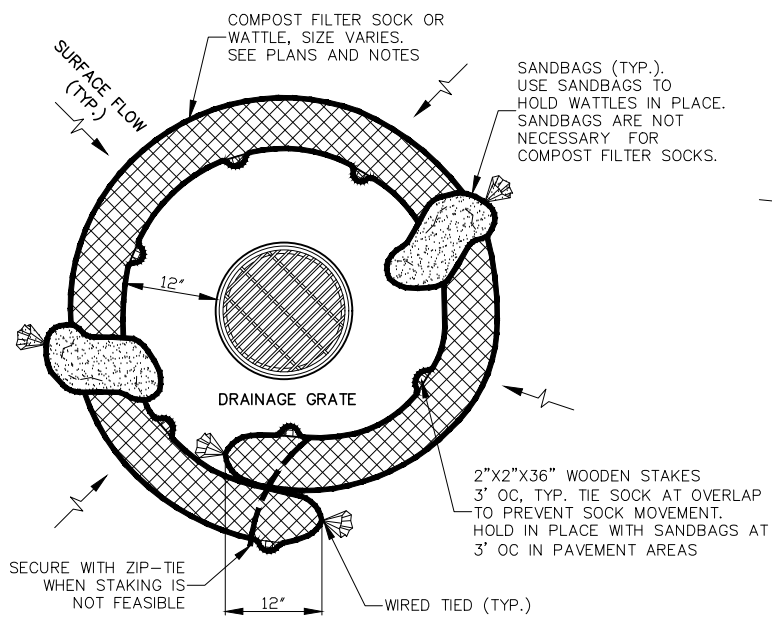

AREA DRAIN PLAN

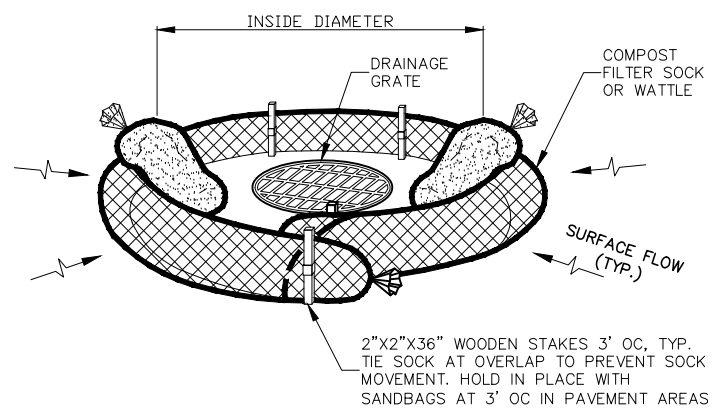

AREA DRAIN PERSPECTIVE VIEW

NOTES FOR PREFABRICATED FILTER INSERTS AND FILTER SOCK

TYPE 1 - PREFABRICATED FILTER INSERTS
INSTALL PREFABRICATED FILTER INSERTS
ACCORDING TO THE PLANS, SPECIAL PROVISIONS,
AND MANUFACTURER RECOMMENDATIONS.
PREFABRICATED INSERTS WITH PROVISIONS FOR
OVERFLOW ARE ALLOWED ONLY WHEN
ACCOMPANIED BY ADDITIONAL BMP'S TO
PREVENT THE POTENTIAL OF SEDIMENTS
ENTERING PROJECT STORM SYSTEMS.
FIELD FABRICATED INSERTS ARE NOT ALLOWED.

TYPE 2 - COMPOST FILTER SOCK
DRIVE 2"x2" WOOD STAKES A MINIMUM OF
6" INTO GROUND AND FLUSH WITH THE TOP
OF THE SOCK.
OVERLAP ENDS OF SOCK PER MANUFACTURERS
RECOMMENDATIONS (12" MIN., 36" MAX.).
USE 8" TO 12" DIA SOCK ON CURBSIDE IN
TRAFFIC AREAS.
USE 12" TO 18" DIA SOCK IN NON-TRAFFIC AREAS
OR AREAS WHERE THE LARGER SOCKS CAN BE
USED SAFELY.
USE SYNTHETIC MESH SOCKS FOR TEMPORARY
INSTALLATIONS.

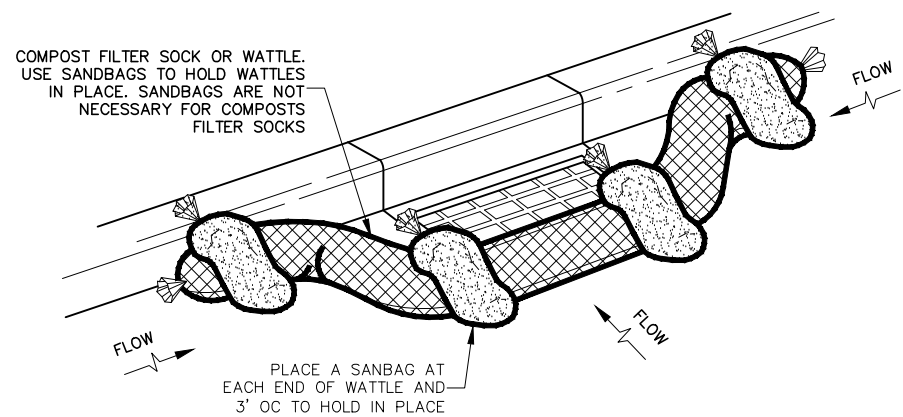

CURB INLET PERSPECTIVE VIEW

COMPOST FILTER SOCK OR WATTLE - TYPE 2
NOT TO SCALE

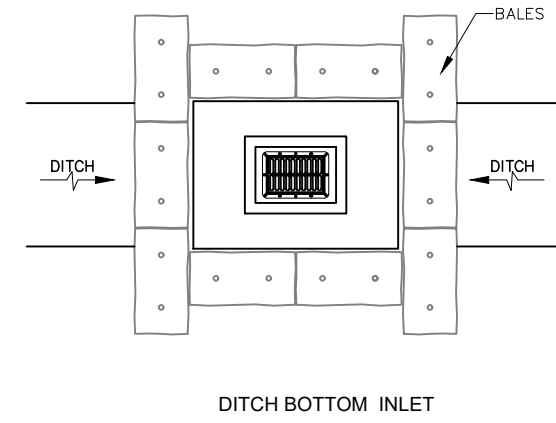

DITCH BOTTOM INLET

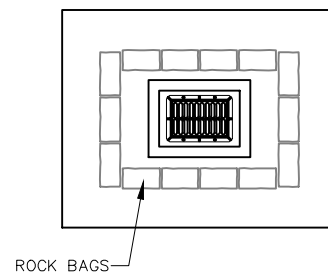

SWALE INLET

PROTECTION ALONG INLETS WITH ROCK BAGS BALES OR APPROVED ALTERNATIVES

NOTES FOR SYNTHETIC BALES OR BALE TYPE BARRIERS:

- 1- TYPE I AND II SYNTHETIC BARRIER SHOULD BE SPACED IN ACCORDANCE WITH CHART 1, SHEET 1 OF 2010 FDOT DESIGN STANDARDS INDEX 102.
- 2- BALES SHALL BE ANCHORED WITH TWO (2) 1"x2" (or 1" dia.) x 4' WOOD STAKES. STAKES OF OTHER MATERIAL OR SHAPE PROVIDING EQUIVALENT STRENGTH MAY BE USED IF APPROVED BY THE ENGINEER. STAKES OTHER THAN WOOD SHALL BE REMOVED UPON COMPLETION OF THE PROJECT.
- 3- RAILS AND POSTS SHALL BE 2"x4" WOOD. OTHER MATERIALS PROVIDING EQUIVALENT STRENGTH MAYBE USED IF APPROVED BY THE ENGINEER.
- 4- ADJACENT BALES SHALL BE BUTTED FIRMLY TOGETHER.
- 5- WHERE USED IN CONJUNCTION WITH SILT FENCE, BALES SHALL BE PLACED ON THE UPSTREAM SIDE OF THE FENCE.

INLET PROTECTION SYSTEM (TYP.) OR APPROVED ALTERNATIVE

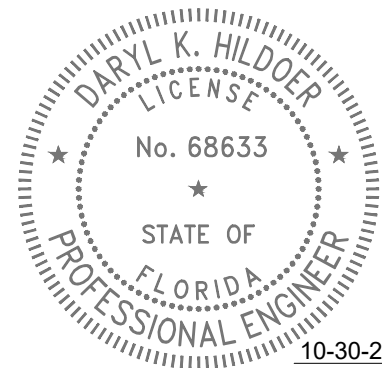

10-30-2025
THIS ITEM HAS BEEN DIGITALLY SIGNED AND SEALED BY DARYL K. HILDOER, P.E. ON THE DATE ADJACENT TO THE SEAL.

PRINTED COPIES OF THIS DOCUMENT ARE NOT CONSIDERED SIGNED AND SEALED AND THE SIGNATURE MUST BE VERIFIED ON ANY ELECTRONIC COPIES.

S:\Hector\George_Sibilia\2025\NE 24 AVE AND NE 197 ST & NE 25 AVE FROM NE 200 ST TO NE 202 ST\20240287\DRAINAGE IMPROVEMENT PROJECT\SH-10 INLET PROTECTION.dwg Sep 24, 2025 - 8:37am E139108

REVISIONS

DATE	BY	DESCRIPTION	DATE	BY	DESCRIPTION

RAINTREE LAKES
NE 24 AVENUE AND NE 197 STREET AND
NE 25 AVENUE FROM
NE 200 STREET TO NE 202 STREET
DRAINAGE IMPROVEMENT PROJECT

DESIGNED BY	NAME	DATE	DRAWN BY	NAME	DATE
G.S.	G.S.	8-22-25	H.S.	H.S.	8-22-25
CHECKED BY	F.G.	8-22-25	CHECKED BY	G.S.	8-22-25
SUPERVISED BY:					

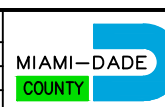

DEPARTMENT OF TRANSPORTATION AND PUBLIC WORKS
ROADWAY ENGINEERING AND RIGHT OF WAY DIVISION
STEPHEN P. CLARK, CENTER
MIAMI, FLORIDA 33128

INLET PROTECTION SYSTEMS DETAILS

STORMWATER POLLUTION PREVENTION PLAN

Narrative Description

The Stormwater Pollution Prevention Plan (SWPPP) Narrative Description contains references to the Contract Documents, the State of Florida Erosion and Sediment Control Designer and Reviewer Manual (E&S Manual), the FDOT Design Standards, and other sheets of these Construction Plans. The complete SWPPP is comprised of several items including: this narrative description, the documents referenced in this narrative, the Contractor's approved Erosion Control (ECP) prepared and submitted in accordance with the Contract Documents, and reports of inspections made during construction. All of which are complementary to the signed and certified SWPPP if one is provided by the Department. Contractor is required to maintain copies of the aforementioned items on site, including all applicable permits.

1. Site Description

- a. Nature of Construction Activities: The project consists of retrofitting of drainage infrastructure in a residential roadway.
- b. Sequence of Major Soil Disturbing Activities: The Contractor shall provide in the ECP a detailed sequence of construction for all construction activities. Each construction phase requires the installation of perimeter control, after clearing and grubbing as necessary for the installation of the controls, prior to beginning any work. The Contractor shall follow the sequence of major activities below, unless the Contractor proposes a different sequence that is equal or better at controlling erosion and trapping sediment and is approved by the Engineer.
 - 1) Clearing and grubbing, earthwork, drainage improvements construction.
 - 2) Final grading and landscaping where necessary.
- c. Area Estimates (Acre)
 - 1) Total Site Area: 2.71 Ac.
 - 2) Total Area of the site that is expected to be disturbed: 0.15 Ac.
- d. Existing data describing the soil or the quality of any discharge from the site and an estimate of the size of the drainage area for each discharge point.
 - 1) Rational runoff coefficient
 - a) Before: 0.54
 - b) During: 0.57
 - c) After construction: 0.54
 - 2) Existing data describing the soil or the quality of discharge from the site: According to the United States Department of Agriculture Natural Resources Conservation Service Soil Survey Report of Dade County Area, Florida, the soil encountered on the project are of urban land Udorthents Association soil, which are categorized as moderately well drained.
 - 3) The size of the drainage area for each outfall: N/A . This project has no outfall.
 - 4) The location of each outfall is provided in item 1.f. below: N/A . This project has no outfall.
- e. Site Map: The associated construction plan sheets will be used as the site map. Locations of the required information are described below. The sheet numbers for all items discussed are identified on the Cover Sheet of the construction plans.
 - 1) Drainage patterns and approximate slopes anticipated after major grading activities: The slopes of the site can be seen on the construction plan sheets.
 - 2) Areas of Soil Disturbance: The areas to be disturbed are indicated on the construction plan sheets. Any areas where permanent features are shown to be constructed above or below ground will be disturbed.
 - 3) An outline of areas which may not be disturbed: These areas of the Project outside the clearing and grubbing and construction activities which comprised of those that are not subject to any soil disturbing activities.
 - 4) The location of major structural and nonstructural controls identified in the plan: Temporary sediment control devices shall be installed all locations where disturbance of solids will occur. Additional measures may be required as necessary where stormwater runoff has the potential to reach surface waters or offsite stormwater collection facilities.
 - 5) The location of areas where stabilization practices are expected to occur, surface waters, wetlands and locations where stormwater is discharged to a surface water or MS4: Areas of permanent stabilization are shown on the Construction Plan Sheets.
- f. Discharge point(s): N/A. This project has no outfall.

2. Controls

- a. Erosion and Sediment Controls: The Contractor shall describe in the ECP the proposed stabilization and structural practices. The Contractor may choose to accept the following guidelines or modify them in the ECP, subject to approval by the Engineer. As work progresses, the Contractor shall modify the plan to adapt to seasonal variation, changes in construction activities, and the need for better management practices. For each construction phase install perimeter controls after clearing and grubbing necessary for installation of controls but before beginning other work for the construction phase. Remove perimeter controls only after all upstream areas are stabilized. In addition :
 - . Furnish and place inlet protection systems to control erosion and siltation.
 - . Install soil tracking prevention devices (STPDs) at all common areas where construction vehicles will be entering and exiting the construction site.
 - . Sediment barriers shall be installed and at the toe of slope of embankments and at locations as described in the Erosion and Sediment Control Details and the E&S Manual.
 - . Inlet protection systems shall be used for all existing and proposed inlets subject to sediment runoff.
 - . Clearing and grubbing operations will be controlled so as to minimize unprotected erodible areas exposed to weather. Areas outside the limits of construction shall not be disturbed.
 - . Excavated material shall not be deposited in locations where the material could be washed away by high water, rain or stormwater runoff. Stockpiles shall be covered or encircle with sediment barriers.
 - . Floating or staked turbidity barrier shall be used in the canals as an extra measure of protection. These devices shall not substitute for upland control devices. Contractor is required to prepare a turbidity contingency plan as part of the erosion control plan.
 - . Erosion control mats may be utilized as an extra measure of protection of embankment or berm construction to prevent erosion.

- 1) Stabilization Practices: In the ECP, the Contractor shall describe the stabilization practices proposed to control erosion. The Contractor shall initiate all stabilization measures as soon as practical, but in no case more than 7 days, in portions of the site where construction activities have temporarily or permanently ceased. The stabilization practices shall include at least the following, unless otherwise approved by the Engineer.
 - a) Temporary: Includes sod, mulch, and artificial coverings in accordance with the Contract Documents.
 - b) Permanent: Includes asphalt or concrete surface, sod, roadside swales, and endwalls in accordance with the Contract Documents.
- 2) Structural Practices: In the ECP, the Contractor shall describe the proposed structural practices to control trap sediment and otherwise prevent the discharge of pollutants from exposed areas of the site. Sediment controls shall be in place before disturbing soil upstream of the control. The structural practices shall include at least the following, unless otherwise approved by the Engineer.
 - a) Temporary: Includes inlet protection systems, sediment barriers, turbidity barriers and soil tracking prevention devices as per the ES&C Manual and the Contract Documents. See Erosion and Sediment Control Details for more information. All sediment controls shall be in place prior to any soil disturbing activity.
 - b) Permanent: Includes roadside swales.
- b. Permanent Stormwater Management Controls: Stormwater runoff will be conveyed in a swale systems with inlets and French drains.
- c. Control for Other Potential Pollutants: The Contractor shall practice good housekeeping by instituting a clean, orderly construction site. The following controls shall be implemented to further reduce pollution at the project site:
 - 1) Waste Disposal: In the ECP, the Contractor shall describe the proposed methods to prevent the discharge of solid materials, including building materials, to waters of the United States. The proposed methods shall include at least the following, unless otherwise approved by the Engineer:
 - a) The Contractor shall demonstrate the proper disposal of all construction waste generated within the project limits. Waste may include, but not be limited to, vegetation from clearing and grubbing activities, packaging materials, scrap building materials, litter from traveling public, sewage from sanitary facilities, herbicides and pesticides and their containers, and hydrocarbon products. Contractor shall designate a waste collection area onsite and delineate the area on the SWPPP Site Map.
 - b) Sanitary/septic facilities shall be provided and maintained in a neat and sanitary condition, for the use of the Contractor's employees as necessary to comply with the requirements and regulations of the State and local boards of health. A licensed Sanitary Waste Management Contractor as required by State Regulations will collect all sanitary waste from portable units.
 - c) The Contractor will provide litter control and collection within the Project limits during construction activities. Contractor will provide an adequate number of litter containers with lids at the staging, stockpile and field office areas (as applicable). Waste collection will be scheduled so that containers are emptied prior to overflow. Spilled litter containers will be cleaned up immediately.
 - 2) Off-Site Vehicle Tracking & Generation of Dust: In the ECP, the Contractor shall describe the proposed methods for minimizing offsite vehicle tracking of sediments and generating dust. The proposed methods shall include at least the following, unless otherwise approved by the Engineer.
 - a) Stabilizing construction entrances as necessary according to the E&S Manual and the Contract Documents.
 - b) The Contractor shall take measures to insure the cleanup of sediments that have been tracked by vehicles or have been transported by wind or stormwater about the site or onto nearby roadways.
 - c) Removing excess dirt from roads daily.
 - d) Using roadway sweepers during dust generating activities such as excavation and milling operations.
 - e) Stabilized construction entrances and construction roads, if appropriate, shall be implemented in order to reduce off-site tracking.
 - f) Loaded haul trucks shall be covered with tarpaulin. Excess dirt on the road shall be removed daily.
- 3) State or Local Regulations: In the ECP, the Contractor shall describe the proposed procedures to comply with applicable State and local regulations for waste disposal, and sanitary sewer or septic systems.
- 4) Application of Fertilizer and Pesticides
 - a) The application and handling of herbicides and pesticides shall be in compliance with the manufacture recommended method and in accordance with FDOT Standard Specifications for Road and Bridge Construction as modified by the Contract Documents.
 - b) Herbicides and pesticides shall be stored on site in their original containers with product label intact.
- 5) Toxic Substances and Materials
 - a) In the ECP, the contractor shall provide a list of toxic substances and materials that are likely to be used on the job and provide a plan addressing the generation, application, migration, storage, and disposal of these substances.
 - b) Contractor shall provide equipment necessary to contain and clean up spills of hazardous materials, including petroleum products. Spills shall be contained and cleaned up immediately after they occur. Spilled material and the equipment used to clean up the spill shall not come in contact with surface waters or be introduced into stormwater. Disposal of surplus product will be done according to manufacturer recommended method.
 - c) Contractor shall provide a project specific Hazardous Materials Spill Control Plan in order to address the handling of hydrocarbon and hazardous materials.

- d) Petroleum products shall be stored in covered areas with secondary containment surrounding container.
- e) Toxic/hazardous materials exposed during construction activities shall be handled per the FDOT Standard Specifications for Road and Bridge Construction as modified by the Contract Documents.
- d. Approved State and Local Plans and Permits
 - Not applicable to this project.
- 3. Maintenance: In the ECP, the Contractor shall provide a plan for maintaining all erosion and sediment controls throughout construction. The maintenance plan shall at a minimum, comply with the following:
 - a. Sediment Barriers: Twelve (12) months, or as required, replacement interval in accordance with Contract's Specifications.
 - b. Inlet Protection Systems at inlets-Check after rainfall events. Clean if clogging occurs.
 - c. The maintenance of these devices shall occur until the Engineer has deemed an area permanently stabilized. It will be the responsibility of the Contractor to remove erosion and sediment control devices once they have served their purpose.
- 4. Inspection
 - a. The Contractor shall be required to conduct daily visual inspections of all temporary and permanent erosion control measures along the project corridor. The Contractor shall maintain, repair and/or replace these items as necessary.
 - b. The Engineer shall have an Inspector review the project's temporary and permanent erosion control measures for the items listed below at least once every seven (7) calendar days and/or within 24 hours of the end of a storm that is 0.5 inches or greater. A written inspection report (form attached) is required every seven calendar days or within 24 hours of the end of a storm that deposits 0.5 inches of rain or greater.
 - 1) Outfalls into the waters of the United States
 - 2) Points of discharge to municipal separated storm sewer systems
 - 3) Disturbed areas of the site that have not been stabilized
 - 4) Areas used for storage of materials that are exposed to precipitation
 - 5) Structural controls
 - 6) Stormwater management systems
 - 7) Locations where vehicles enter or exit this site
 - 8) Check that the approved or revised Erosion Control Plan is followed
 - 9) Where sites have been stabilized, inspections shall be conducted at least once every month.
 - c. The Contractor shall initiate repairs within 24 hours of inspections that indicate items are not in good working order.
 - d. If inspections indicate that the installed stabilization and structural practices are not sufficient to minimize erosion, retain sediment, and prevent discharging pollutants, the Contractor shall provide additional measures, as approved by the Engineer.
- 5. Non-Stormwater Discharges
 - a. In the ECP, the Contractor shall identify all anticipated non-stormwater discharges (except flows from fire fighting activities). The Contractor shall describe the proposed measures to prevent pollution from these non-stormwater discharges.
 - b. If contaminated soil or groundwater is encountered during construction, the Contractor is to cease operations in that area. The Contractor shall contact the Miami-Dade County, Regulatory and Economic Resource (R.E.R.) Compliance Desk, at (305) 372-6955.

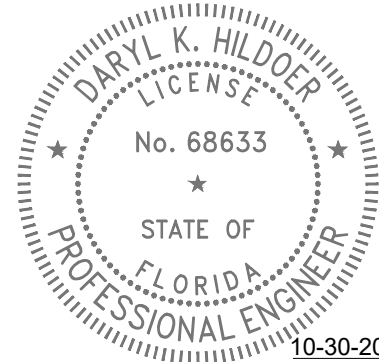

THIS ITEM HAS BEEN DIGITALLY SIGNED AND SEALED BY DARYL K. HILDOER, P.E. ON THE DATE ADJACENT TO THE SEAL.

PRINTED COPIES OF THIS DOCUMENT ARE NOT CONSIDERED SIGNED AND SEALED AND THE SIGNATURE MUST BE VERIFIED ON ANY ELECTRONIC COPIES.

REVISIONS

DATE	BY	DESCRIPTION	DATE	BY	DESCRIPTION

RAINTREE LAKES
NE 24 AVENUE AND NE 197 STREET AND
NE 25 AVENUE FROM
NE 200 STREET TO NE 202 STREET
DRAINAGE IMPROVEMENT PROJECT

DESIGNED BY	NAME	DATE	DRAWN BY	NAME	DATE
	G.S.	8-22-25		H.S.	8-22-25
CHECKED BY	F.G.	8-22-25	CHECKED BY	G.S.	8-22-25
SUPERVISED BY:					

DEPARTMENT OF TRANSPORTATION AND PUBLIC WORKS
ROADWAY ENGINEERING AND RIGHT OF WAY DIVISION
STEPHEN P. CLARK, CENTER
111 NW 1st
MIAMI, FLORIDA 33138

STORMWATER POLLUTION PREVENTION PLAN

S:\hector\George_Sibilia\2025\NE 24 AVE AND NE 197 ST & NE 25 AVE FROM NE 200 ST TO NE 202 ST\20240287\DRAINAGE IMPROVEMENT PROJECT\SH-11 STORMWATER POLLUTION PREVENTION PLAN.dwg Sep 24, 2025 - 8:36am E:139108