

ELECTRONIC DOCUMENTS DISCLAIMER

1. Electronic copies of the solicitation documents are made available on this website solely for the convenience of prospective bidders (whether as a prime contractor or sub-contractor) on the Project, and are not considered part of the Contract Documents. No representation or warranty is made, either expressed or implied, with regard to the accuracy or suitability of these electronic copies for any purpose whatsoever. In the event of discrepancies or conflicts between the County's originally published document(s) and any other version distributed or submitted by other parties, the County's original hard copy version shall prevail.
2. Miami-Dade County Department of Transportation and Public Works (DTPW) does not track or monitor downloads of Project documents from this website. Therefore, prospective bidders who choose to use this method of distribution shall also be responsible for monitoring the site and downloading any applicable addenda or supplemental information. DTPW will distribute hard copy addenda or supplemental information only to those persons or firms who we have purchased a hard copy of the original solicitation documents.
3. Miami-Dade County shall not be responsible for errors and omissions occurring in the transmission or downloading of any documents or specifications from this website. In the event of any discrepancy between information obtained from this website and the DTPW hard copy solicitation documents and specifications, the terms of the hard copy documents will prevail.
4. Miami-Dade County does not guarantee continuous, uninterrupted or secure access to this or other related websites. Operation of this website may be affected from time to time by numerous factors outside of our control. In the event that we are notified of any problems in a timely manner we will do our best to assist with those problems that fall within our control. For assistance, contact us at 305-375-2930. Solicitation documents are removed from this website as soon as possible after the due date.
5. DTPW does not accept facsimile or electronic bid responses of any kind. All bids must be submitted in writing, on the forms provided by the County, to the address designated in the bid package. It is the bidder's responsibility to ensure that their submittals are received at the designated location, complete and on time. Bids received after the due date will be rejected, even if the solicitation is still appearing on this site.
6. With regards to Miscellaneous Construction Contracts (MCC) 7040 Plan Request for Price Quotations:
 - a. Only bidders included on the Project's Bidders List, provided by the Internal Service Department, Procurement Management Division to the DTPW, can submit a bid.
 - b. Only timely bids received from bidders included in the Project's Bidders List will be considered.
7. These documents shall not be altered in any manner. Utilization or viewing of these electronic documents shall constitute implicit acknowledgement and acceptance of these provisions. Failure to comply with these provisions may result in rejection of your bid.

CONTRACT SPECIFICATIONS

DEPARTMENT OF TRANSPORTATION
& PUBLIC WORKS
CAPITAL IMPROVEMENTS DIVISION

BID DOCUMENTS

KITCHEN REMODELING IN THE
BREAKROOM OF PALMETTO
METRORAIL STATION

CONTRACT NO.: CICC 7040 PLAN

RPQ NO.: TP-0000014679

SEPTEMBER 6, 2023



RPQ NO.: 14679

DEPARTMENT OF TRANSPORTATION AND PUBLIC WORKS

BID DOCUMENTS

KITCHEN REMODELING IN THE BREAKROOM OF PALMETTO METRORAIL STATION

RPQ NO. TP-0000014679

BID DOCUMENTS - TABLE OF CONTENTS

BID DOCUMENTS

INVITATION TO BID

MINIMUM QUALIFICATIONS AND REQUIREMENTS

FORMS FOR BIDDING

RPQ Bid Form - Attachment 5A.
Bid Form
All Addendums (if applicable/Signed by Contractor)
Bid Submittal Check List Questionnaire Appendix "D"
Bidder's Statement of Qualifications and Business References
Scrutinized Company Affidavit
Non-Collusion Affidavit
Firm's Responsibility Combined Affidavit
SBE Requirement-Certificate of Assurance (COA)

CONTRACT FORMS

Fair Wage Affidavit
Financial Documentation
DPM Requirement – Affirmation of Vendor Affidavits
Job Clearinghouse Form
Fair Subcontracting Practices
E-Verify Affidavit
Certificate(s) of Insurance

ADDITIONAL CONTRACT REQUIREMENTS

SPECIAL PROVISIONS

LPC TRACKER AND SAFETY DIRECTIVE 182536 / RESOLUTION No. 1181-18

STANDARD CONSTRUCTION GENERAL CONTRACT CONDITIONS AND ATTACHMENTS

TECHNICAL SPECIFICATIONS

KITCHEN SPECIFICATIONS

DRAWINGS

DEPARTMENT OF TRANSPORTATION AND PUBLIC WORKS

BID DOCUMENTS

KITCHEN REMODELING IN THE BREAKROOM OF PALMETTO METRORAIL STATION

RPQ NO. TP-0000014679

INVITATION TO BID

Department of Transportation and Public Works

Capital Improvements Division
111 NW 1st Street Suite 1410
Miami FL 33128



MIAMI-DADE COUNTY, FLORIDA
REQUEST FOR PRICE QUOTATION (RPQ)

Contract No: MCC 7040 Plan - CICC 7040-0/07
RPQ No: 14679

INVITATION TO BID

A RPQ has been issued for the work identified below. If you are interested in submitting a bid for this project, please submit your bid via Sealed Envelopes, attention to Clerk of the Board at 111 NW 1st Street, 17th floor, Miami Fl. 33128 no later than 10/11/2023 at 02:00 PM. If you have any questions, contact LAURA HERNANDEZ at 3053753234.

This RPQ is issued under the terms and conditions of the Miscellaneous Construction Contracts (MCC) Program MCC 7040 Plan.

RPQ DETAILED BREAKDOWN

Bid Due Date:	10/11/2023	Time Due:	02:00 PM	Submitted Via:	Sealed Envelopes	SBE-Con. Level:	1
Estimated Value:	\$59,050 (excluding Contingencies and Dedicated Allowances)						
Project Name:	Kitchen Remodeling in the Breakroom of Palmetto Metrorail Station						
Project Location:	7701 NW 79 Ave, Medley FL 33166						
License Requirements:	Primary:	General Building Contractor; General Engineering					
Scope of Work:	<p>(Contractor must obtain and submit all permits prior to performing any work). Work includes but is not limited to furnishing all supervision, labor, materials, equipment, tools, permits, and performing all operations necessary for the remodeling of the Lounge room (breakroom) and to provide a temporary lounge room during the remodeling period. Specific work tasks Includes:</p> <ol style="list-style-type: none"> 1. Demolition and disposal of an existing 88 inches long kitchen cabinets, upper and lower units. 2. Demolition and disposal of approximately 156 square feet of flooring. 3. Painting of the entire room area. 4. Furnish and install: <ol style="list-style-type: none"> a. Approximately 88 inches of upper and lower cabinets. Cabinets should be outdoor grade, brand Weather Strong from Home Depot or equal. b. New sink, with two-handle water faucet. c. Electric Water heater. d. New dedicated microwave oven electrical outlet. e. New dedicated water cooler electrical outlet. f. New plumbing for sink, water cooler, and electric water heater installation. g. New VCT flooring and a vinyl baseboard 6 inches high. h. Broken drop ceiling titles. i. During the breakroom remodel period, contractor will be required to rent a 32-foot by 8-foot office trailer, complete with a restroom, kitchenette, and air conditioning, for use as a breakroom during the remodel period. Acceptable Manufacturer: Willscot, 5000 NW 72nd Ave, Miami FL 33166. Phone: (305) 592-7379. 5. Work must be warrantee for a period of one (1) year from the final acceptance of the Work. All manufacture's warranties to be transferred to the County. <p>B. Prior to the NTP, the Contractor and his subcontractors must submit an employee list of names of the workers who will be performing work at the facility to the project manager. DTPW personnel will perform background checks on each of those employees before issuing the required security clearance and provide DTPW badges to those working on the DTPW property. The employee list must include the name, date of birth and Social Security number for clearance.</p> <p>C. If any changes required due to conflict of design and or field conditions, the Engineer would make the final determination.</p> <p>D. The Contractor and all subcontractors, under this Contract, are prohibited from performing any work, other than specified in the Contract and/or directed by the Engineer, within the limits of the project site, without prior written notification to the Engineer. This includes any work for private or commercial entities.</p>						
Document Pickup:	Contact:	DTPW Capital Improvements Division	Phone No:	305-375-5309	Date:	9/6/2023	
	Location:	111 NW 1st. Street, Miami Florida 33128 Suite 1410					
Pre-Bid Meeting::	YES	Mandatory:	No	Date:	9/21/2023	Time:	10:00 AM
	Location:	Pre Bid Meeting-See notes below					
Site Meeting:	No	Mandatory:	No	Date:		Time:	
	Location:						
Bid shall be submitted to:	Contact:	Clerk of the Board					
	Address:	111 NW 1st Street, 17th floor, Miami Fl. 33128					
	Email:	valveo2@Miamiidade.gov				FAX # :	
Type of Contract:	Multiple Trade		Method of Award:	Lowest Responsible Bidder			
Method of Payment:	Scheduled Monthly Payments		Insurance Required:	YES			
Additional Insurance Required:	YES	If Yes - Minimum Coverage:		\$1,000,000.00			
Performance & Payment Bond Required:	YES	Bid Bond Required:		YES			

Prevailing Wage Rate Required:	N/A	Davis Bacon:	NO	Maintenance Wages:	NO	AIPP:	NO	Amount:	
SBE-Con. Requirements:	YES	Percentage:	100.00%	SBD Certificate of Assurance Form Required:	YES				
DBE Participation:	NO	Percentage:	0.00%	DBE Subcontractor Forms Required:	NO				
CWP Requirements:	NO	Percentage:	0.00%						
SBE-S Requirements	NO	Percentage:	0.00%						
SBE-G Requirements	NO	Percentage:	0.00%						
Liquidated Damages:	YES	\$\$ Per Day:	\$492.80						
Trade Set-a-side:	NO		If Yes, Trade =						
For RQP's less than \$10,000, if no LD rate is specified, the County reserves the right to assess actual damages in lieu of LDs.									
Design Drawing Included:	YES	Shop Drawing Included:	NO	Specifications Included:	YES				
Anticipated Start Date:	4/4/2024			Calendar Days for Project Completion:	120				
Comments:	<p>LOCATION OF WORK:</p> <p>A. This is a work order driven contract. The locations of work to be performed under the terms of this Contract have been tentatively listed as follows:</p> <p>1.7701 NW 79 Ave, Medley FL 33166.</p> <p>B. The exact locations and limits of construction are shown on plans accompanying these Contract Documents. The County may update the work site list subsequent to the Award of this Contract by adding, deleting, or substituting with comparable sites. The combined total cost for all work authorized by the Work Order(s) shall not exceed the Contract Award amount.</p> <p>LICENSE REQUIREMENTS:</p> <p>At the time of Bid and pursuant to the requirements of Section 10-3 of the Code of Miami-Dade County, Florida and these Solicitation and Contract Documents, the Bidder must hold a valid, current, and active:</p> <p>a. Certificate of Competency from the County's Construction Trades Qualifying Board as General Building Contractor or:</p> <p>b. Certification, as a General Contractor pursuant to the provisions of Section 489.115 of the Florida Statutes.</p> <p>EXPERIENCE:</p> <p>1. The Bidder must demonstrate that it has full-time personnel with the necessary experience to perform the Project's Scope of Work. This experience shall include work in successfully completed projects performed by the identified personnel whose bulk of work performed in the Public Right-of-Way is similar in detail to the Project's Scope of Work described in these Solicitation Documents. Demonstrate the experience requirement by:</p> <p>a. Providing a detailed description of at least three (3) projects similar in detail to the Project's Scope of Work described in these Solicitation Documents and in which the Bidder's identified personnel is currently engaged or has completed within the past five years. List and describe the aforementioned projects and state whether the work was performed for the County, other government clients, or private entities. The description must identify for each project:</p> <ol style="list-style-type: none"> 1) The identified personnel and their assigned role and responsibilities for the listed project 2) The client's name and address including a contact person and phone number for reference 3) Description of work 4) Total dollar value of the contract 5) Contract duration 6) Statement or notation of whether Bidder's referenced personnel is/was employed by the prime contractor or subcontractor, and 7) For completed projects, provide letters of certification of final acceptance or similar project closure documentation issued by the client and available Contractor's performance evaluations. <p>2. The County reserves the right to request additional information and/or contact listed persons pertaining to bidder's experience.</p> <p>INDEMNIFICATION AND INSURANCE REQUIREMENTS</p> <p>The Contractor shall furnish to Department of Transportation and Public Works, 111 NW 1 Street, Miami Florida 33128, Certificate(s) of Insurance which indicate that insurance coverage has been obtained which meets the requirements as outlined below:</p> <p>A. Worker's Compensation Insurance for all employees of the Contractor as required by Florida Statute 440.</p> <p>B. Commercial General Liability with products/completed operations for a minimum of \$1,000,000 each occurrence \$2,000,000 aggregate. Miami-Dade County must be included as additional insured.</p> <p>C. Automobile Liability covering all owned, non-owned and hired vehicles for a minimum of \$1,000,000 combined single limit.</p> <p>BID DOCUMENTS:</p> <p>Bidding documents may be purchased from the Miami-Dade County Department of Transportation and Public Works, Capital Improvements Division, 111 NW 1st Street, 14th Floor,</p>								

Miami, Florida 33128 for a non-refundable fee of One Hundred Dollars (\$100.00) per each complete set of documents. Payment shall be in the form of a company check, cashier's check, or money order payable to the "Miami-Dade County, Department of Transportation and Public Works". Documents can also be downloaded for free at: <https://www.miamidade.gov/apps/isd/StratProc/Home/CurrentSolicitations>.

ADDENDUMS - RFI'S

All RFI requests should be e-mailed to Laura.Hernandez@miamidade.gov while copying the Clerk of the Board (clerkbcc@miamidade.gov).

The Department of Transportation and Public Works has made changes with regard to how addendums and requests for information (RFI) will be sent to document holders. Be advised that all Addendums, RFI's, and the document holders list (bidder's list) are now available to view online at the following web address:

<https://www.miamidade.gov/apps/isd/StratProc/Home/CurrentSolicitations>

Therefore, during the advertisement period, the Department will not be sending these documents via certified mail. All document holders must provide a dedicated e-mail address. The Department will only be sending addendums and RFIs by e-mail and posting online at the aforementioned link. The bidders list will be updated every Friday during the advertisement phase of the contract. Please be aware that acknowledgment of receipt of all addendums and RFI's remain a requirement when submitting bids.

VENDOR REGISTRATION:

Due to the new Vendor Registration procedures of the Internal Service Department, Procurement Management Division, updated definitions along with the "Affirmation of Vendor Affidavits" has been added to the Bid Submittal Package. The successful bidder must be registered under this new procedure prior to award.

PRE-BID - BID SUBMITTAL DUE DATE:

Pre-Bid Conference date, time and location: Thursday, September 21, 2023, at 10:00 A.M. The Department of Transportation and Public Works (DTPW) has scheduled a non-mandatory Site Visit Meeting. The Site Visit Meeting will be held on Thursday, September 21, 2023, at the following location: Breakroom of Palmetto Metrorail Station - 7701 NW 79 Avenue, Medley, Miami, FL 33166.

If the bidder does not arrive on time for the Site Visit Meeting and Pre-Bid meeting, there is no guarantee that he/she will be allowed to attend. Contractors must RSVP in writing to Laura.Hernandez@miamidade.gov and copy clerkbcc@miamidade.gov no later than Close of Business on September 19, 2023.

Additional Site Visit Meetings may be scheduled based on the number of RSVPs received. If additional site visit meetings are scheduled, DTPW will notify the Contractors in writing advising of which day and time they will be scheduled.

Bid Due Date, Opening Time & Location:

Bid Submittal Time and Location: Wednesday, October 11, 2023, 2:00 PM, at 111 NW 1st Street, 17th Floor, Clerk of the Board Office.

Bid Opening immediately after in the 18 Floor.

DISCLOSURE:

- Contractor shall indemnify and hold harmless the County and its officers, employees, agents and instrumentalities from any and all liability, losses or damages, including attorneys' fees and costs of defense, which the County or its officers, employees, agents or instrumentalities may incur as a result of claims, demands, suits, causes of actions or proceedings of any kind or nature arising out of, relating to or resulting from the performance of this Agreement by the Contractor or its employees, agents, servants, partners principals or subcontractors. Contractor shall pay all claims and losses in connection therewith and shall investigate and defend all claims, suits or actions of any kind or nature in the name of the County, where applicable, including appellate proceedings, and shall pay all costs, judgments, and attorney's fees which may issue thereon. Contractor expressly understands and agrees that any insurance protection required by this Agreement or otherwise provided by the Contractor shall in no way limit the responsibility to indemnify, keep and save harmless and defend the County or its officers, employees, agents and instrumentalities as herein provided.

The Contractor shall furnish to **Department of Transportation and Public Works, Capital Improvements Division, 111 NW 1st Street Suite 1410, Miami FL 33128**, Certificate(s) of Insurance which indicate that insurance coverage has been obtained which meets the requirements as outlined below:

- A.** Worker's Compensation Insurance for all employees of the Contractor as required by Florida Statute 440.
 - a. If applicable should include coverage required under the U.S. Longshoremen and Harbor Workers' Act (USL&H) and/or Jones Act for any activities on or about navigable water.
- B.** Commercial General Liability in an amount not less than \$300,000 per occurrence, and \$600,000 in the aggregate. Miami-Dade County must be shown as an additional insured with respect to this coverage.
- C.** Automobile Liability Insurance covering all owned, non-owned and hired vehicles used in connection with the work, in an amount not less than \$300,000 combined single limit per occurrence for bodily injury and property damage.

*Under no circumstances are Contractors permitted on the Aviation Department, Aircraft Operating Airside (A.O.A) at Miami International Airport without increasing automobile coverage to \$5 million. Only vehicles owned or leased by a company will be authorized. \$1 million limit applies at all other airports.

- All 7040 RPQs are 100% Set-aside solicitations - solely for certified Small Business Enterprise-Construction (SBE-Con) firms registered in the MCC 7040 Plan. Registered SBE-Con firms are invited to bid based on the project's primary license requirement, estimated value and the contractors' certification participation level. The SBE-Con Participation Level will be stipulated on the RPQ and the Invitation to Bid or in the Project's Solicitation Documents. **All bidders prime and sub contractors must be SBE-Con certified.**
- All Prime Contractors submitting a bid for RPQ/Project with a Small Business Measures (s) MUST submit the Small Business Development "CERTIFICATE OF ASSURANCE" form properly completed, signed and notarized with their bid document at the time of Bid Submittal. FAILURE TO SUBMIT THE REQUIRED CERTIFICATE OF ASSURANCE FORM AT THE TIME OF BID SUBMISSION SHALL RENDER THE BID NON COMPLIANT TO THE CONTRACT REQUIREMENT AND SECTION 10.33.02 OF THE CODE OF MIAMI-DADE COUNTY.
- 7040 and 7360 RPQs with an estimated project value in excess of \$700,000.00 may be assigned a Small Business Enterprise Goods (SBE-G) or Small Business Services (SBE-S) program goal. The SBE-G or SBE-S goal if applicable will be stipulated on the RPQ and the Invitation to Bid or in the Project's Solicitation Documents.
- All RPQs with an estimated project value \$100,000 or above are subject to Responsible Wage Rates. The wage rate will be stipulated on the RPQ and the Invitation to Bid or in the Project's Solicitation Documents.
- All Projects, where price (Proposals/Bids) received are in excess of \$200,000 will require the submission of the Payment and Performance Bond as required by State of Florida Statute.

VERIFICATION OF EMPLOYMENT ELIGIBILITY (E-VERIFY):

By entering the Contract, the Awarded Bidder becomes obligated to comply with the provisions of Section 448.095, Florida Statute, titled "Verification of Employment Eligibility." This includes but is not limited to utilization of the U.S. Department of Homeland Security's E-Verify System to verify the employment eligibility of all newly hired employees by the Awarded Bidder effective, January 1, 2021, and requiring all Subcontractors to provide an affidavit attesting that the Subcontractor does not employ, contract with, or subcontract with, an unauthorized alien. Failure to comply may lead to termination of this Awarded Bidder, or if a Subcontractor knowingly violates the statute, the subcontract must be terminated immediately. Any challenge to termination under this provision must be filed in the Circuit Court no later than twenty (20) calendar days after the date of termination. If this Contract is terminated for a violation of the statute by the Awarded Bidder, the Awarded Bidder may not be awarded a public contract for a period of one year after the date of termination, and the Awarded Bidder may be liable for any additional costs incurred by the County resulting from the termination of the Contract. Public and private employers must enroll in the E-Verify System (<http://www.uscis.gov/e-verify>) and retain the I-9 Forms for inspection.

DEPARTMENT OF TRANSPORTATION AND PUBLIC WORKS

BID DOCUMENTS

KITCHEN REMODELING IN THE BREAKROOM OF PALMETTO METRORAIL STATION

RPQ NO. TP-0000014679

FORMS FOR BIDDING

RPQ Bid Form - Attachment 5A.

Bid Form

All Addendums (if applicable/Signed by Contractor)

Bid Submittal Check List Questionnaire Appendix "D"

Bidder's Statement of Qualifications and Business References

Scrutinized Company Affidavit

Non-Collusion Affidavit

Firm's Responsibility Combined Affidavit

SBE Requirement-Certificate of Assurance (COA)

All bids must be received by the due date and time. The County will not consider bids received after the due date and time.

Bids are to be submitted sealed with all necessary affidavits and supporting documentation attached. Bids are to be delivered to the Clerk of the Board at 111 NW 1st Street, 17th Floor, Miami, Florida, 33128. **All envelopes must be stamped at the reception desk with the date and time. Failure to submit with your bid the forms stipulated above may render the bid non-responsive.**

DEPARTMENT OF TRANSPORTATION AND PUBLIC WORKS

BID DOCUMENTS

KITCHEN REMODELING IN THE BREAKROOM OF PALMETTO METRORAIL STATION

RPQ NO. TP-0000014679

RPQ BID FORM - ATTACHMENT 5A

Department of
Transportation and Public
Works
701 NW 1st CT
Miami, FL 33136



MIAMI-DADE COUNTY, FLORIDA
REQUEST FOR PRICE QUOTATION (RPQ)
Contract No: MCC 7040 Plan - CICC
7040-0/07 RPQ No: TP-0000014679

RPQ BID FORM – ATTACHMENT 5A

RPQ Project Name: Kitchen Remodeling in the Breakroom of Palmetto Metrorail Station.

Price Proposal (Cost to Perform the work **must** be stated here. State 'No Bid' if not submitting a price proposal)

\$

Bidder's Company Name: _____

Company Address: _____

City: _____ **State:** _____ **Zip:** _____

Telephone No: _____ **Fax No:** _____ **E-Mail:** _____

THE EXECUTION OF THIS FORM CONSTITUTES THE UNEQUIVOCAL OFFER OF PROPOSER TO BE BOUND BY THE TERMS OF ITS PROPOSAL. FAILURE TO SIGN THIS SOLICITATION WHERE INDICATED BELOW BY AN AUTHORIZED REPRESENTATIVE SHALL RENDER THE PROPOSAL NON-RESPONSIVE. THE COUNTY MAY, HOWEVER, IN ITS SOLE DISCRETION, ACCEPT ANY PROPOSAL THAT INCLUDES AN EXECUTED DOCUMENT WHICH UNEQUIVOCALLY BINDS THE PROPOSER TO THE TERMS OF ITS OFFER.

Name of Person Submitting Quote (Print): _____

Number of Addendums received: _____ (if none' write "None")

Signature: _____ **Date:** _____

Note: Quotes must be submitted on this form. Quote envelope must state RPQ Number, date and time due and the Bidder's Name. Use of any other form for submission of the price quotation shall result in the rejection of the price quotation. Late bids will not be opened. *Low bidder will be notified, in the Recommendation of Award, of the requirements to submit current copies of insurance certificates in accordance with the Contract Documents. By signature, the CONTRACTOR agrees to be bound by the terms set forth in the MCC 7040 Plan.*

DEPARTMENT OF TRANSPORTATION AND PUBLIC WORKS

BID DOCUMENTS

KITCHEN REMODELING IN THE BREAKROOM OF PALMETTO METRORAIL

STATION RPQ NO. TP-0000014679

BID FORM

DEPARTMENT OF TRANSPORTATION AND PUBLIC WORKS
BID DOCUMENTS
KITCHEN REMODELING FOR PALMETO STATION

PALMETTO METRO RAIL STATION, 7701 NW 79 AVENUE, MEDLEY, FL. 33166

RPQ NO. TP-00000014679

To: Miami-Dade County

Bid Opening Date: _____

Board of County Commissioners

Bid Opening Time: _____

Miami, Florida

Local Time

Gentlemen:

We _____

Bidder's Name

have received, have examined and are familiar with the Contract Documents bearing the title **KITCHEN REMODELING FOR PALMETO STATION AT 7701 NW 79 AVENUE, MEDLEY, FL. 33166- RPQ NO. TP-00000014649**, the forms for the Submittal of Bids and have included the cost of their provisions, in our Bid. We have examined, are familiar with, and do accept the conditions of the Work site and other conditions affecting the Work.

Addendum No. _____ Dated _____

Addendum No. _____ Dated _____

Addendum No. _____ Dated _____

Addendum No. _____ Dated _____

Failure to acknowledge receipt of all addenda may cause the bid to be considered not responsive to the invitation, which would require rejection of the bid.

PROJECT RPQ No.: 14679

PROJECT NAME: KITCHEN REMODELING FOR PALMETO STATION

IF THIS PROPOSAL IS ACCEPTED, THE UNDERSIGNED BIDDER AGREES TO COMPLETE ALL WORK IN ACCORDANCE WITH THIS CONTRACT WITHIN THE CONTRACT DURATION SPECIFIED IN THE CONTRACT DOCUMENTS. PRICING SHALL BE INCLUSIVE OF ALL REQUIREMENTS TO COMPLETE THE SCOPE OF WORK AND IN ACCORDANCE WITH THE CONTRACT DOCUMENTS.

Item No.	Division of Work:	Unit	Quantity	Total Price
1	Kitchen Remodeling, Includes all electrical and plumbing	LS	1	\$
2	Flooring	LS	1	\$
3	Drop Ceiling Tile Replacement	LS	1	
4	Painting	LS	1	
5	Temporary trailer (all inclusive)	LS	1	
6	Permits	LS	1	

BASE BID TOTAL \$ _____

(Instructions: The spaces provided in the Total Price Column(s) for the Bid Line Item(s) must be filled in and no spaces left blank. The sum of the Bid Line Items must represent your Base Bid Total. Failure to submit a complete and accurate Bid Form may result in your bid found non-responsive.)

A TEN PERCENT (10%) CONTINGENCY ALLOWANCE AND OTHER DEDICATED ALLOWANCES AS REQUIRED WILL BE ADDED TO THE BASE BID TOTAL AS STIPULATED IN THE SPECIAL PROVISIONS.

PROJECT RPQ No.: 14679

A. CONVICTION DISCLOSURE:

Pursuant to Section 2-8.6 of the Code of Miami-Dade County, any individual, corporation, partnership, joint venture or other legal entity having an officer, director, or executive who has been convicted of a felony during the past ten (10) years shall disclose this information at the time of bid submittal.

Place a check mark here **only** if the Bidder has such conviction to disclose to comply with this requirement.

B. WAIVER OF CONFIDENTIALITY AND TRADE SECRET TREATMENT OF BID:

The Bidder acknowledges and agrees that the submittal of the Bid is governed by Florida’s Government in the Sunshine Laws and Public Records Laws, as set forth in Florida Statutes Section 286.011 and Florida Statutes Chapter 119. As such, all material submitted as part of, or in support of, the Bid will be available for public inspection after opening of bids and may be considered by the County in public.

By submitting a bid pursuant to this solicitation, Bidder agrees that all such materials may be considered to be public records. The Bidder shall not submit any information in response to this solicitation which the Bidder considers to be a trade secret, proprietary or confidential. In the event that the Bid contains a claim that all or a portion of the Bid submitted contains confidential, proprietary or trade secret information, the Bidder, **by signing below**, knowingly and expressly **waives** all claims made that the Bid, or any part thereof no matter how indicated, is confidential, proprietary or a trade secret and authorizes the County to release such information to the public for any reason.

LICENSE NO. _____ BIDDER'S NAME _____

BIDDER'S TELEPHONE NUMBER _____ BIDDER'S ADDRESS _____

BIDDER'S FEIN NUMBER _____ BIDDER'S SIGNATURE _____

THE BIDDER UNDERSTANDS AND AGREES THAT THE BASE BID TOTAL AND ALL APPLICABLE ALLOWANCES ARE INCLUSIVE OF ALL WORK NECESSARY TO COMPLETE THE SCOPE OF WORK AS DESCRIBED IN THE CONTRACT DOCUMENTS, AND IF THIS PROPOSAL IS ACCEPTED, THE BIDDER AGREES TO ENTER INTO AND EXECUTE THE CONTRACT WITH THE NECESSARY BOND AND ACCEPT THE ABOVE BASE BID, INCLUSIVE OF ALL ALLOWANCES, AS FULL COMPENSATION FOR THE WORK PERFORMED UNDER THIS CONTRACT.

DEPARTMENT OF TRANSPORTATION AND PUBLIC WORKS

BID DOCUMENTS

KITCHEN REMODELING IN THE BREAKROOM OF PALMETTO METRORAIL STATION

RPQ NO. 14679

ADDENDUM ACKNOWLEDGEMENT FORM
(IF APPLICABLE/ SIGNED BY CONTRACTOR)

MIAMI-DADE COUNTY
DEPARTMENT OF TRANSPORTATION AND PUBLIC WORKS (DTPW)

PROJECT: Kitchen Remodeling in the Breakroom of Palmetto Metrorail Station
Project No. TP-0000014679

ACKNOWLEDGEMENT OF ADDENDA
(Must be completed and submitted with required solicitation documents)

Instructions: Complete Part I or Part II, as applicable.

PART I: Listed below are the dates of issue for each Addendum received in connection with this solicitation.

Addendum #1, Dated _____,	202__
Addendum #2, Dated _____,	202__
Addendum #3, Dated _____,	202__
Addendum #4, Dated _____,	202__
Addendum #5, Dated _____,	202__
Addendum #6, Dated _____,	202__
Addendum #7, Dated _____,	202__
Addendum #8, Dated _____,	202__
Addendum #9, Dated _____,	202__
Addendum #10, Dated _____,	202__

PART II:

____ No Addendum was received in connection with this solicitation.

Authorized Signature: _____ Date: _____

Print Name: _____ Title: _____

Firm Name: _____

DEPARTMENT OF TRANSPORTATION AND PUBLIC WORKS

BID DOCUMENTS

KITCHEN REMODELING IN THE BREAKROOM OF PALMETTO METRORAIL STATION

RPQ NO. TP-0000014679

BID SUBMITTAL CHECK LIST QUESTIONNAIRE

APPENDIX "D"

QUESTIONNAIRE

Appendix D



IN ORDER TO PROVIDE INFORMATION NECESSARY IN DETERMINING THE QUALIFICATIONS OF THE PROPOSER, PLEASE PROVIDE THE INFORMATION LISTED BELOW

#	QUESTION	ANSWER
1	Have you carefully read the Instruction To Prospective Contractors?	<input type="checkbox"/> YES <input type="checkbox"/> NO
2	Have you carefully reviewed the entire Contract Documents as identified within the Instruction To Prospective Contractors?	<input type="checkbox"/> YES <input type="checkbox"/> NO
3	If identified in the Contract Documents, have you carefully inspected the site of the work?	<input type="checkbox"/> YES <input type="checkbox"/> NO <input type="checkbox"/> N/A
4	Have you requested, in writing, of the contact person identified in the Advertisement, any clarifications necessary to submit a responsive proposal? Have you received a written response of clarification?	<input type="checkbox"/> YES <input type="checkbox"/> NO <input type="checkbox"/> YES <input type="checkbox"/> NO <input type="checkbox"/> N/A
5	Are you licensed and certified to perform the work for which you are submitting this proposal? License No.: Competency No.: FEIN No.: Qualifier's Name:	<input type="checkbox"/> YES <input type="checkbox"/> NO _____ _____ _____ _____
6	Are you registered with the Miami-Dade County Department of Procurement Management (DPM)?	<input type="checkbox"/> YES <input type="checkbox"/> NO
7	Have you made any changes or written any codicils to the Contract Proposal?	<input type="checkbox"/> YES <input type="checkbox"/> NO
8	How many previous Contracts with Miami-Dade County in the past five (5) years?	_____
9	Total dollar value of Contracts with Miami-Dade County in the past five (5) years?	_____
10	How many years has your Company been in business with the same Principals?	_____
11	Applicable Federal Requirement Certifications	<input type="checkbox"/> YES <input type="checkbox"/> NO <input type="checkbox"/> N/A

DEPARTMENT OF TRANSPORTATION AND PUBLIC WORKS

BID DOCUMENTS

KITCHEN REMODELING IN THE BREAKROOM OF PALMETTO METRORAIL STATION

RPQ NO. TP-0000014679

MINIMUM QUALIFICATIONS & REQUIREMENTS

LICENSE REQUIREMENT:

- Hold a current Certificate of Competency from the County's Construction Trades Qualifying Board as General Building Contractor.
- Certification as a General Contractor, pursuant to the provisions of Section 489.511 of the Florida Statutes (F.S.).

EXPERIENCE REQUIREMENT:

The Bidder must demonstrate that it has full-time personnel with the necessary experience performing a similar Scope of Work and at least five (5) years of experience. Demonstrate the experience requirement by:

- Providing a detailed description of at least three (3) projects similar in detail to the Project's Scope of Work described in these Solicitation Documents and in which the Bidder's identified personnel is currently engaged or has completed within the past five years. List and describe the aforementioned projects and state whether the work was performed for the County, other government clients, or private entities. The description must identify for each project:

The identified personnel and their assigned role and responsibilities for the listed project

2. The client's name and address including a contact person and phone number for reference
3. Description of work
4. Total dollar value of the contract
5. Contract duration
6. Statement or notation of whether Bidder's referenced personnel is/was employed by the prime contractor or subcontractor, and
7. For completed projects, provide letters of certification of final acceptance or similar project closure documentation issued by the client and available Contractor's performance evaluations.

- The County reserves the right to request additional information and/or contact listed persons pertaining to the bidder's experience.

DEPARTMENT OF TRANSPORTATION AND PUBLIC WORKS BID

DOCUMENTS

KITCHEN REMODELING IN THE BREAKROOM OF PALMETTO

METRORAIL STATIONN

PROJECT No. TP-0000014679

SCRUTINIZED COMPANIES AFFIDAVIT

By executing the Scrutinized Companies with Activities in Sudan or Iran Petroleum Energy Sector Lists Affidavit through a duly authorized representative, the bidder certifies that the bidder is not on the Scrutinized Companies with Activities in Sudan List or the Scrutinized Companies with Activities in the Iran Petroleum Energy Sector List, as those terms are used and defined in sections 287.135 and 215.473 of the Florida Statutes. In the event that the bidder is unable to provide such certification, the bidder shall execute the Affidavit through a duly authorized representative. In such event, the bidder shall furnish together with its bid a duly executed written explanation of the facts supporting any exception to the requirement for certification that it claims under Section 287.135 of the Florida Statutes. The bidder agrees to cooperate fully with the County in any investigation undertaken by the County to determine whether the claimed exception would be applicable. The County shall have the right to terminate any Contract resulting from this solicitation for default if the bidder is found to have submitted a false certification or to have been, or is subsequently during the term of the Contract, placed on the Scrutinized Companies for Activities in Sudan List or the Scrutinized Companies with Activities in the Iran Petroleum Energy Sector List.

**AFFIDAVIT
SCRUTINIZED COMPANIES WITH ACTIVITIES IN SUDAN
OR IRAN PETROLEUM ENERGY SECTOR LISTS
FLORIDA STATUTES 215.473**

Pursuant to 287.135, F.S., the { _____ } (“Entity”) must disclose, if the Entity or any of its officers, directors, or executives are doing certain types of business in or with Sudan or Iran.

Indicate below if the above named Entity, as of the date of submission:

_____ has not engaged in commerce in any form in Sudan or Iran, including, but not limited to, acquiring, developing, maintaining, owning, selling, possessing, leasing, or operating equipment, facilities, personnel, products, services, personal property, real property, or any other apparatus of business or commerce.

_____ has engaged in commerce with Sudan or Iran, including, but not limited to, acquiring, developing, maintaining, owning, selling, possessing, leasing, or operating equipment, facilities, personnel, products, services, personal property, real property, or any other apparatus of business or commerce.

(CORPORATE SEAL)

CONTRACTOR

(Legal Name of Corporation)

ATTEST:

Secretary _____
(Signature and Seal)

By: _____
Contractor – Signature

(Type Name & Title)

Name: _____

(Type Name & Title)

DEPARTMENT OF TRANSPORTATION AND PUBLIC WORKS

BID DOCUMENTS

KITCHEN REMODELING IN THE BREAKROOM OF PALMETTO METRORAIL STATION

RPQ NO. 14679

NON-COLLUSION AFFIDAVIT



NON-COLLUSION AFFIDAVIT

(In accordance with [Sections 2-8.1.1](#) and [10-33.02.1](#) of the Code of Miami-Dade County)

I, the undersigned, am over 18 years of age, have personal knowledge of the facts stated in the Non-Collusion Affidavit (*this Affidavit*) and I am an owner, officer, director, principal shareholder and/or otherwise authorized to bind the Bidder/Proposer of this solicitation.

A. I have reviewed the list of respondents attached to this Affidavit. I state that the Bidder/Proposer of this competitive solicitation (check one):

is **not related** to any of the other respondents submitting a Bid/Proposal in the competitive solicitation.

is **related** to the following respondents who submitted a Bid/Proposal in the competitive solicitation, which are identified and listed below:

B. I state that the Bidder/Proposer of this competitive solicitation:

1. has prepared this Bid/Proposal independently without consultation, communication, agreement or arrangement with any other Bidder/Proposer or competitor for the purpose of restricting competition;
2. has submitted the Bid/Proposal in its own behalf, and not in the interest or on behalf of any person not therein named;
3. has not, directly or indirectly, induced or solicited any other Bidder/Proposer to put in a sham proposal, or any other person, firm, or corporation to refrain from proposing;
4. has not in any manner sought by collusion to secure an advantage over any other Bidder/Proposer.

Note: Any person or entity that fails to submit this executed Affidavit shall be ineligible for contract award. In accordance with Section 2-8.1.1 of the Code of Miami-Dade County, where two or more related parties, as defined herein, each submit a Bid for any contract, such Bids shall be presumed to be collusive. The foregoing presumption may be rebutted by the presentation of evidence as to the extent of ownership, control and management of such related parties in preparation and submittal of such Bids. **Related parties** shall mean the Bidder/Proposer; the principals, corporate officers, and managers of a Bidder/Proposer; or the spouse, domestic partner, parents, stepparents, siblings, children or stepchildren of a Bidder/Proposer or the principals, corporate officers and managers thereof which have a direct or indirect ownership interest in another Bidder/Proposer for the same contract or in which a parent company or the principals thereof of one Bidder/Proposer have a direct or indirect ownership interest in another Bidder/Proposer for the same contract. Bid/Proposal found to be collusive shall be rejected. Bidder/Proposer who has been found to have engaged in collusion may be considered non-responsible, and may be suspended or debarred, and any contract resulting from collusive bidding may be terminated for default.

Written Declaration: Pursuant to §92.525, Florida Statutes, under penalties of perjury, I declare that I have read the foregoing Affidavit and that the facts stated in it are true, accurate, and complete.

Solicitation No.: _____ Solicitation Title: _____

By: _____
Signature of Affiant

Date: _____ 20 ____

Printed Name of Affiant and Title

____/____/____-____/____/____/____/____
Federal Employer Identification Number

Printed Name of Bidder/Proposer

Address of Bidder/Proposer

DEPARTMENT OF TRANSPORTATION AND PUBLIC WORKS

BID DOCUMENTS

KITCHEN REMODELING IN THE BREAKROOM OF PALMETTO METRORAIL STATION

RPQ NO. 14679

FIRM'S RESPONSIBILITY COMBINED AFFIDAVIT

FIRM'S RESPONSIBILITY AFFIDAVIT
"COMBINED AFFIDAVIT"

STATE OF FLORIDA)
) SS:
COUNTY OF MIAMI-DADE)

The undersigned, being first duly sworn, states as follows:

GENERAL

1. I am a duly authorized representative of the Firm submitting a bid, proposal or other document to Miami-Dade County with the intention of being awarded a contract (referred to in this affidavit as the "Respondent").
2. This Affidavit is made of my personal knowledge. I understand that Miami-Dade County will rely on the representations made in this affidavit in determining my eligibility and responsibility to enter into a contract with Miami-Dade County. By executing this affidavit, the Respondent agrees to provide to Miami-Dade County such documentation or other proof as Miami-Dade County may require verifying the accuracy and completeness of any of the representatives.
3. The Respondent is duly authorized to submit this bid or proposal, and if awarded the contract, to enter into the contract and perform the services or supply the goods contemplated in the contract.

OWNERSHIP DISCLOSURE

4. That in compliance with Section 2-8.1(d)(1) of the Miami Dade County Code, if the contract or business transaction is with a corporation, the full legal name and business address shall be provided for each officer and director and each stockholder who holds directly or indirectly five percent (5%) or more of the corporation's stock. If the contract or business transaction is with a trust, the full legal name and address shall be provided for each trustee and each beneficiary. All such names and addresses are (Post Office addresses are not acceptable). The full legal names and business address of any other individual (other than subcontractors, materialmen, suppliers, laborers, or lenders) that have, or will have, any interest (legal, equitable beneficial or otherwise) in the contract or business transaction with Miami-Dade County are (Post Office addresses are not acceptable). This information shall be supplied on the attached Ownership Disclosure form (Attachment "A") and signed by the Respondent.

Combined Affidavit Initial

EMPLOYMENT DISCLOSURE

5. The following information and attachments are provided and are in compliance with all items in County Ordinance No. 90-133, amending Section 2.8-1; Subsection (d) (2):

a. Does your firm have a collective bargaining agreement with its employees?
 Yes No

b. Does your firm provide paid health care benefits for its employees?
 Yes No

c. Provide a current breakdown (number of persons) of your firm’s work force and ownership as to race, national origin and gender:

White:	_____	Males:	_____	Females:	_____
Asian:	_____	Males:	_____	Females:	_____
Black:	_____	Males:	_____	Females:	_____
American					
Indian:	_____	Males:	_____	Females:	_____
Hispanics:	_____	Males:	_____	Females:	_____
Aleut					
(Eskimo):	_____	Males:	_____	Females:	_____
_____:	_____	Males:	_____	Females:	_____

EMPLOYMENT DRUG FREE WORKPLACE

6 . The Respondent provides a drug-free workplace in full compliance with Section 2-8.1.2 of the Code of Miami-Dade County.

EMPLOYMENT FAMILY LEAVE

7. That in compliance with Ordinance No. 91-142 of the Code of Miami-Dade County, Florida, the following information is provided and is in compliance with all items in the aforementioned Ordinance:

An employee who has worked for the above firm for at least one (1) year shall be entitled to ninety (90) days of family leave during any twenty-four (24) month period, for medical reasons, for the birth or adoption of a child, or for the care of a child, spouse or other close relative who has a serious health condition without risk of termination of employment or employer retaliation.

Combined Affidavit Initial

ARREARS WITH THE COUNTY

8. That in compliance with Ordinance No. 95-178 and Section 2-8.1(c) of the Code of Miami-Dade County, the Proposer has paid all delinquent and currently due fees or taxes, including but not limited to real estate and personal property taxes, registered in the name of Proposer and which are collected in the normal course by the Miami-Dade County Tax Collector, and that County issued parking tickets for vehicles registered in the name of the above proposer, and which are collected in the normal course by the Miami-Dade Clerk of the Circuit and County Courts, have been paid.

That in compliance with Ordinance No. 99-162 and Section 2-8.1 of the Code of Miami-Dade County, the Proposer is not in arrears in any payment under contract, promissory note or other loan document with Miami-Dade County, or any of its agencies or instrumentalities, including the Public Health Trust, either directly or indirectly through a firm, corporation, partnership or joint venture in which the individual or entity has a controlling financial interest as that term is defined in Section 2-11.1(b)(8) of the Code of Miami-Dade County.

CODE OF BUSINESS ETHICS

9. I, being duly sworn, hereby state and certify that this firm has adopted a Code of Business Ethics that is fully compliant with the requirements of Section 2-8.1(i) of the Code of Miami-Dade County as amended. I further acknowledge that failure to comply with the adopted Code of Business Ethics shall render any contract with Miami-Dade County voidable, and subject this firm to debarment from County work pursuant to Section 10-38 (h)(2) of the Code of Miami-Dade County as amended. I further acknowledge that failure to submit this affidavit shall render this firm ineligible for contract award.

NO CRIMINAL RECORD

10. The Respondent has not been convicted of a felony during the past ten (10) years, nor does it, as of the date of the bid or proposal submission, have an officer, director or executive who has been convicted of a felony during the past ten (10) years as defined in Section 2-8.6 of the Code of Miami-Dade County.

PUBLIC ENTITY CRIME

11. The respondent has not been convicted of a Public Entity crime as defined in Paragraph 287.133(1)(g) of the Florida Statutes. Violation of any State or Federal law with respect to the transaction of business with any public entity or with an agency or political subdivision of any State.

Combined Affidavit Initial

DEBARMENT AND SUSPENSION DISCLOSURE

- 12 . The Respondent, and its officers, principals, stockholders, subcontractors or its affiliates are not debarred or suspended from contracting with Miami-Dade County as regulated by Section 10-38 of the Miami Dade County Code.

NON -DISCRIMINATION BASED ON DISABILITY

- 13 . The Respondent is in compliance with and agrees to continue to comply with and assure any subcontractor, or third party contractor under this project complies with all applicable laws forbidding discrimination based on disability including, but not limited to those provisions pertaining to employment, provision of programs and services, transportation, communications. Access to facility, renovations and new construction as set forth in the Americans with Disabilities Act of 1990 (ADA), the Rehabilitation Act of 1973, the Federal Transit Act and the Fair Housing Act.

FAIR SUBCONTRACTING

- 14 . Consistent with Section 2-8.8 of the Code of Miami-Dade County, the Respondent has adopted subcontracting policies and procedures which (a) notifies the broadest number of local subcontractors of the opportunity to be awarded a subcontract; (b) invites local subcontractors to submit bids in a practical, expedient way; (c) provides local subcontractors access to information necessary to prepare and formulate a subcontracting bid; (d) allows local subcontractors to meet with appropriate personnel of the Respondent to discuss the Respondent's requirements; and (e) awards subcontracts based on full and complete consideration of all submitted proposals and in accordance with the Respondent's stated objectives.

RESPONSIBLE WAGE AND BENEFITS (IF APPLICABLE)

- 15 . If applicable, the Respondent is in full compliance with Section 2-11.16 of the Code of Miami-Dade County, and should he or she be awarded the contract, understands his or her obligation to pay the project minimum wage rates set forth in that Section and the labor provisions of the contract documents.

Combined Affidavit Initial

CLEARINGHOUSE AFFIDAVIT

- 16. That in compliance with Miami-Dade County Resolution Number R-1145-99, the Respondent agrees to comply with all requirements of the Clearinghouse Resolution and Job Request form for posting job opportunities. Making it a mandatory requirement for Respondents to post notice of job opportunities resulting from the construction of improvements on County property through the County's Clearinghouse process.

I STATE NOTHING FURTHER IN THIS AFFIDAVIT.

Signature: _____
Position/Title: _____
Name of Firm: _____

The foregoing was sworn and subscribed before me this _____ day of _____, _____ by _____, who is personally known to me or who has produced _____ as identification who being duly sworn, deposes and says that the above is true to the best of his knowledge, information and belief.

My Commission expires:

NOTARY PUBLIC
STATE OF FLORIDA

DEPARTMENT OF TRANSPORTATION AND PUBLIC WORKS

BID DOCUMENTS

KITCHEN REMODELING IN THE BREAKROOM OF PALMETTO METRORAIL STATION

RPQ NO. 14679

SMALL BUSINESS ENTERPRISE (SBE)
CERTIFICATE OF ASSURANCE (COA)

SBE Requirement - Certificate of Assurance (COA)

For all projects with approved **SBE-CON**, **SBE-A/E**, **SBE-G**, and **SBE-S** “**Set-Aside**” or “**Goal**” measures, all bidders are required to submit a Small Business Development (SBD) Certificate of Assurance (COA) at the time of bid submission. The COA must be completely filled out, signed, notarized, and submitted with each bid in order for the bidder to be deemed compliant by SBD. **Failure to submit the required COA at the time of bid submittal will result in the bidder being deemed non-compliant and not eligible for award of the contract.**

Successful first, second, and third ranked bidders will subsequently be notified to complete a Utilization Plan (UP), within a specified time frame, for SBD’s review and approval via Miami-Dade County’s online Business Management Workforce System (BMWS). The UP shall list all certified Miami-Dade County Small Business Enterprise (SBE) subcontractor(s), subconsultant(s), and/or sub-vendor(s) that will satisfy the project’s established SBE measure(s). Each SBE subcontractor, subconsultant, and/or sub-vendor will also be required to confirm its contractual relationship via BMWS, within the specified time frame, for final approval by SBD. The COA and UP requirements do not apply to “No Measure” open market projects; however, all prime and subcontractor(s), subconsultant(s), and/or sub-vendor(s) will be required to report and confirm all payments made on Miami-Dade County projects.



SMALL BUSINESS DEVELOPMENT
CERTIFICATE OF ASSURANCE (COA)

SMALL BUSINESS PARTICIPATION ON COUNTY PROJECTS

This form must be submitted with bid documents by all bidders/proposers on a Miami-Dade County project with Small Business Enterprise ("SBE") program measure(s).

Project No.: _____ Project Title: _____

Name of Bidder/Proposer: _____ Contact Person _____

Address: _____ City _____ State _____ ZIP _____

Phone Number: _____ Email address: _____

The bidder/proposer is committed to meeting the established measure(s) assigned to this project: _____ % SBE-A/
_____ 100 % SBE-Cons, ___ Trade Set-aside SBE-Cons, _____ % SBE-G, and/or _____ % SBE-S.

(For Goals, write in the percentage. For Set-aside, put a check mark or x.)

Print Prime Bidder's Name & Title _____ Prime Bidder's Signature _____ Date _____

To satisfy the requirements for Step 1 - Bid Submittal and Compliance with Small Business Enterprise Program(s), the following are required:

- 1. Acknowledgement of the SBE-A/E, SBE-Cons, SBE-G and/or SBE-S measure(s) established for this project via this Certificate of Assurance.
2. Agree to engage in the solicitation of approved Miami-Dade County Small Business Enterprise firm(s) to achieve the established measure(s) as indicated in the Project Documents (specifications).
3. Agree to submit a list of certified SBEs to satisfy the measures via Miami-Dade County's Business Management Workforce System ("BMWS") within the specified timeframe, upon email notification from the Small Business Development ("SBD") Division or BMWS.

To satisfy the requirements for Step 2 - Bid Evaluation and Recommendation for Award, please attest that:

I understand that my company will be deemed non-compliant and not eligible for award if I fail to (1) submit this form with my bid documents and/or (2) submit my company's Utilization Plan which shall list all certified Miami-Dade County Small Business Enterprise firms whom will be subcontracted with to satisfy the project's established SBE measure(s) via BMWS, within the specified timeframe, upon email notification from SBD or BMWS. Each SBE subcontractor, subconsultant, and/or sub-vendor will also be required to confirm its contractual relationship via BMWS, within the specified timeframe, for final approval by SBD.

STATE OF FLORIDA

COUNTY OF MIAMI-DADE

BEFORE ME, an officer duly authorized to administer oaths and take acknowledgement, personally appeared _____, who being first sworn deposes and affirms that the provided information statements are true and correct to the best of his/her knowledge information and belief.

Signature of Owner

SWORN TO and subscribed before me this _____ day of _____, 20_____

Signature of Notary Public-State of Florida

My Commission Expires:

DEPARTMENT OF TRANSPORTATION AND PUBLIC WORKS

BID DOCUMENTS

KITCHEN REMODELING IN THE BREAKROOM OF PALMETTO METRORAIL STATION

RPQ NO. TP-0000014679

CONTRACT FORMS

Fair Wage Affidavit

Financial Documentation

DPM Requirement – Affirmation of Vendor Affidavits Job

Clearinghouse Form

Fair Subcontracting Practices

E-Verify Affidavit

Certificate(s) of Insurance

FAIR WAGE AFFIDAVIT



miamidade.gov

Internal Services Department
Small Business Development
111 NW 1 Street, 19th Floor
Miami, Florida 33128
T 305-375-3111 F 305-375-3160

FAIR WAGE AFFIDAVIT

Before me, the undersigned authority appeared _____ the
(PRINT NAME)

_____ of _____,
(PRINT TITLE) (PRINT NAME OF BIDDER OR PROPOSER)

who attests that _____ shall pay workers on
(PRINT NAME OF BIDDER OR PROPOSER)

the project minimum wage rates in accordance with Responsible Wages and Benefits, Section 2-
11.16 of the Code of Miami-Dade County and the Labor Provisions of the contract documents.

State of FLORIDA

County of Miami-Dade

Sworn to (or affirmed) and subscribed before me this _____ day of _____, 202_____.

_____ Personally, known or _____ produced identification.

(Signature of Notary Public - State of Florida)

(Print, Type, or Stamp Commissioned Name of Notary Public)

Type of identification produced: _____



DEPARTMENT OF TRANSPORTATION AND PUBLIC WORKS

BID DOCUMENTS

KITCHEN REMODELING IN THE BREAKROOM OF PALMETTO METRORAIL STATION

RPQ NO. TP-0000014679

FINANCIAL DOCUMENTATION

As a condition of award, the Contractor be required to provide documentation that affirm its financial capacity to perform the work (i.e., Tax Returns, Financial Statements, Profit-and-Loss Statements, Cash Flow Statements, etc.).

DEPARTMENT OF TRANSPORTATION AND PUBLIC WORKS BID

DOCUMENTS

KITCHEN REMODELING IN THE BREAKROOM OF PALMETTO METRORAIL STATION

PROJECT NO. TP-0000014679

DEPARTMENT OF PROCUREMENT MANAGEMENT (DPM)

AFFIRMATION OF VENDOR AFFIDAVITS

Bidders are required to affirm that all information submitted with the Vendor Registration Package is current, complete and accurate as a condition of award, by completing the provided Affirmation of Vendor Affidavit Form.



New Vendor Registration and Bid/Proposal Contract Language

1.1. DEFINITIONS FOR VENDOR REGISTRATION

Bid – shall refer to any offer(s) submitted in response to this solicitation.

Bidder – shall refer to anyone submitting a Bid in response to this solicitation.

Bid Solicitation – shall mean this solicitation documentation, including any and all addenda.

Bid Submittal Form – defines the requirement of items to be purchased, and must be completed and submitted with Bid. The Bidder should indicate its name in the appropriate space on each page.

County – shall refer to Miami-Dade County, Florida

DPM – shall refer to Miami-Dade County's Department of Procurement Management.

Enrolled Vendor – shall refer to a firm that has completed the necessary documentation in order to receive Bid notifications from the County.

Registered Vendor – shall refer to a firm that has completed the Miami-Dade County Business Entity Registration Application and has satisfied all requirements to enter into business agreements with the County.

The Vendor Registration Package – shall refer to the Business Entity Registration Application.

For additional information about on-line vendor enrollment or vendor registration contact the Vendor Assistance Unit at 111 N.W. 1st Street, 13th Floor, Miami, FL 33128, Phone 305-375-5773. Vendors can enroll online and obtain forms to register by visiting our web site at www.miamidade.gov/dpm

1.2. INSTRUCTIONS TO BIDDERS

A. Bidder Qualification

It is the policy of the County to encourage full and open competition among all available qualified vendors. All vendors regularly engaged in the type of work specified in the Bid Solicitation are encouraged to submit Bids. Vendors may enroll with the County to be included on a notification list for selected categories of goods and services. To be eligible for award of a contract (including small purchase orders), Bidders must become a Registered Vendor. Only Registered Vendors can be awarded County contracts. Vendors are required to register with the County by contacting the Vendor Assistance Unit. The County endeavors to obtain the participation of all qualified small business enterprises. For information and to apply for certification, contact the Department of Small Business Development at 111 N.W. 1st Street, 19th Floor, Miami, FL 33128-1900, or telephone at 305-375-3111. County employees and board members wishing to do business with the County are referred to Section 2-11.1 of the Miami-Dade County Code relating to Conflict of Interest and Code of Ethics.

B. Vendor Registration

To be recommended for award the County requires that vendors complete a Miami-Dade County Vendor Registration Package. Effective June 1, 2008, a new Vendor Registration Package, including a Uniform Affidavit Packet (Affidavit form), must be completed by vendors and returned to the Department of Procurement Management (DPM), Vendor Assistance Unit, within fourteen (14) days of notification of the intent to recommend for award. In the event the Vendor Registration Package is not properly completed and returned within the specified time, the County may in its sole discretion, award to the next lowest responsive, responsible Bidder. The Bidder is responsible for obtaining the Vendor Registration Package, including all affidavits by downloading from the DPM website at www.miamidade.gov or from the Vendor Assistance Unit at 111 N.W. 1st Street, 13th Floor, Miami, FL 33128.

Bidders are required to affirm that all information submitted with the Vendor Registration Package is current, complete and accurate, at the time they submit a response to a Bid Solicitation, by completing the provided Affirmation of Vendor Affidavit form.

In becoming a Registered Vendor with Miami-Dade County, the vendor confirms its knowledge of and commitment to comply with the following:

1. **Miami-Dade County Ownership Disclosure Affidavit**
(Sec. 2-8.1 of the County Code)
2. **Miami-Dade County Employment Disclosure Affidavit**
(County Ordinance No. 90-133, amending Section 2-8.1(d)(2) of the County Code)
3. **Miami-Dade County Employment Drug-free Workplace Certification**
(Section 2-8.1.2(b) of the County Code)
4. **Miami-Dade Disability and Nondiscrimination Affidavit**
(Article 1, Section 2-8.1.5 Resolution R182-00 Amending R-385-95)
5. **Miami-Dade County Debarment Disclosure Affidavit**
(Section 10.38 of the County Code)
6. **Miami-Dade County Vendor Obligation to County Affidavit**
(Section 2-8.1 of the County Code)
7. **Miami-Dade County Code of Business Ethics Affidavit**
(Article 1, Section 2-8.1(j) and 2-11(b)(1) of the County Code through (6) and (9) of the County Code and County Ordinance No 00-1 amending Section 2-11.1(c) of the County Code)
8. **Miami-Dade County Family Leave Affidavit**
(Article V of Chapter 11 of the County Code)

9. **Miami-Dade County Living Wage Affidavit**
(Section 2-8.9 of the County Code)

10. **Miami-Dade County Domestic Leave and Reporting Affidavit**
(Article 8, Section 11A-60 11A-67 of the County Code)

11. **Subcontracting Practices**
(Ordinance 97-35)

12. **Subcontractor /Supplier Listing**
(Ordinance 97-104)

13. **Environmentally Acceptable Packaging**
Resolution (R-738-92)

14. **W-9 and 8109 Forms**

The vendor must furnish these forms as required by the Internal Revenue Service.

15. **Social Security Number**

In order to establish a file for your firm, you must provide your firm's Federal Employer Identification Number (FEIN). If no FEIN exists, the Social Security Number of the owner or individual must be provided. This number becomes your "County Vendor Number". To comply with Section 119.071(5) of the Florida Statutes relating to the collection of an individual's Social Security Number, be aware that DPM requests the Social Security Number for the following purposes:

- Identification of individual account records
- To make payments to individual/vendor for goods and services provided to Miami-Dade County
- Tax reporting purposes
- To provide a unique identifier in the vendor database that may be used for searching and sorting departmental records

16. **Office of the Inspector General**

Pursuant to Section 2-1076 of the County Code.

17. **Small Business Enterprises**

The County endeavors to obtain the participation of all small business enterprises pursuant to Sections 2-8.2, 2-8.2.3 and 2-8.2.4 of the County Code and Title 49 of the Code of Federal Regulations.

18. **Antitrust Laws**

By acceptance of any contract, the vendor agrees to comply with all antitrust laws of the United States and the State of Florida.

C. PUBLIC ENTITY CRIMES

To be eligible for award of a contract, firms wishing to do business with the County must comply with the following:

Pursuant to Section 287.133(2)(a) of the Florida Statutes, a person or affiliate who has been placed on the convicted vendor list following a conviction for a public entity crime may not submit a Bid on a contract to provide any goods or services to a public entity, may not submit a Bid on a contract with a public entity for the construction or repair of a public building or public work, may not submit Bids on leases of real property to a public entity, may not be awarded or perform work as a contractor, supplier, subcontractor, or consultant under a contract with any public entity, and may not transact business with any public entity in excess of the threshold amount provided in Section 287.017 of the Florida Statutes, for CATEGORY TWO for a period of 36 months from the date of being placed on the convicted vendor list.

DEPARTMENT OF TRANSPORTATION AND PUBLIC WORKS

BID DOCUMENTS

KITCHEN REMODELING IN THE BREAKROOM OF PALMETTO METRORAIL STATION

PROJECT NO. TP-0000014679

SBD JOB CLEARINGHOUSE AFFIDAVIT

“The attention of the Contractor is hereby directed to the requirements of Job Clearinghouse Code §2-1701 and Resolution No. R-1395-05.

COUNTY'S CLEARINGHOUSE: Pursuant to Miami-Dade County Resolution R-1145-99, Contractors involved in the construction of improvements on County property must post a notice of job opportunities with the Miami-Dade County Job Clearinghouse. For information regarding the Miami-Dade County's Clearinghouse program, please contact the County's Division of Small Business Development at (305) 375-3157.



Delivering Excellence Every Day

JOB CLEARINGHOUSE AFFIDAVIT
Notice of Construction Job Opportunities

Project / Contract Number: _____

Pursuant to Miami-Dade County Resolution No. R-1395-05, there are ___ open position(s) to submit to the Job Clearinghouse for this project at this time. All open positions will be submitted to South Florida Workforce at <https://iapps.careersourcesfl.com/jchcwp/>.

(Signature of Affiant)

(Date)

(Printed Name of Affiant, Title, and Firm Name)

(Witness)

Sworn to and subscribed before me this
_____ day of _____ 20 ____

By: _____

Signature of Notary Public

- Personally Known
- Produced ID

Type of ID produced _____

DEPARTMENT OF TRANSPORTATION AND PUBLIC WORKS

BID DOCUMENTS

KITCHEN REMODELING IN THE BREAKROOM OF PALMETTO METRORAIL STATION

PROJECT NO. TP-0000014679

FAIR SUBCONTRACTING PRACTICES

Consistent with Section 2-8.8 of the Code of Miami-Dade County, the Bidder has adopted subcontracting policies and procedures which (a) notifies the broadest number of local subcontractors of the opportunity to be awarded a subcontract; (b) invites local subcontractors to submit bids in a practical, expedient way; (c) provides local subcontractors access to information necessary to prepare and formulate a subcontracting bid; (d) allows local subcontractors to meet with appropriate personnel of the Respondent to discuss the Respondent's requirements; and (e) awards subcontracts based on full and complete consideration of all submitted proposals and in accordance with the Respondent's stated objectives.

DEPARTMENT OF TRANSPORTATION AND PUBLIC WORKS

BID DOCUMENTS

KITCHEN REMODELING IN THE BREAKROOM OF PALMETTO METRORAIL STATION

PROJECT NO. TP-0000014679

E-VERIFY AFFIDAVIT

Miami-Dade County

E-Verify Affidavit

Executive Order 11-02 requires all Florida State agencies under the direction of the Governor to use E-Verify to confirm the employment eligibility of all current and prospective employees (including subcontractors) assigned to perform work pursuant to a state agency contract. Executive Order 11-116 clarifies that the requirement for state contractors to use E-Verify applies to "all contracts for the provision of goods and services to the state in excess of nominal value."

In accordance with the State requirement, Miami-Dade County requires all vendors doing business with the County who are awarded state-funded contracts to verify employee eligibility using the E-verify system. It is the responsibility of the awarded vendor to insure compliance with E-verify requirements at all times.

To enroll in E-Verify, employers should visit the E-Verify website (<http://www.uscis.gov/e-verify>) and follow the instructions. The employer must, as usual, retain the I-9 Forms for inspection.

By affixing your signature below you hereby affirm that you have complied with E-Verify requirements.

Federal Employer Identification Number (FEIN): _____

_____	_____	_____
Printed Name of Affiant	Printed Title of Affiant	Signature of Affiant
_____	_____	_____
Name of Firm		Date
_____	_____	_____
Address of Firm	State	Zip Code

Notary Public Information

Notary Public -- State of _____ County of _____

Subscribed and sworn to (or affirmed) before me this _____ day of, _____ 20____

by _____ He or she is personally known to me or has produced identification

Type of identification produced _____

_____	_____
Signature of Notary Public	Serial Number
_____	_____
Print or Stamp of Notary Public	Expiration Date
_____	_____
	Notary Public Seal

DEPARTMENT OF TRANSPORTATION AND PUBLIC WORKS

BID DOCUMENTS

KITCHEN REMODELING IN THE BREAKROOM OF PALMETTO METRORAIL STATION

PROJECT NO. TP-0000014679

CERTIFICATE(S) OF INSURANCE
(TO BE PROVIDED BY CONTRACTOR)

DEPARTMENT OF TRANSPORTATION AND PUBLIC WORKS

BID DOCUMENTS

KITCHEN REMODELING IN THE BREAKROOM OF PALMETTO METRORAIL

STATION RPQ NO. TP-0000014679

SPECIAL PROVISIONS

1.0 SCOPE OF WORK:

Refer to Section 01 11 00 – Summary of Work. The Contractor is responsible for verifying all quantities to perform this work. Refer to the contract documents.

2.0 COMMUNITY WORKFORCE PROGRAM:

Community Workforce Program (CWP) goal is not applicable for this project. Additional information is available at the County's website at <http://www.miamidade.gov/business/contract-requirements.asp#0>.

3.0 LOCAL PREFERENCE:

The attention of the Contractor is hereby directed to the requirements of the Code of Miami-Dade County, Chapter 2, Article I, Section 2-8.5; **LOCAL PREFERENCE ORDINANCE**.

The award of this solicitation is subject to Section 2-8.5 of the County Code, which except where Federal or State law mandates to the contrary, allow preference to be given to a local business. For the purposes of the applicability of this Code section, "local business" means the bidder has a valid business tax receipt issued by Miami-Dade County at least one year prior to bid submission, and a physical business address located within the limits of Miami-Dade County from which the vendor operates or performs business. A Post Office Box cannot be used to establish a physical address.

"Pursuant to the general terms and conditions of the solicitation document, local preference is applicable to this solicitation. However, please be advised that the reciprocity agreement with Broward County expired September 30, 2017. Accordingly, local preference will only be afforded to a firm that meets the requirements for Miami-Dade County in any solicitation with a due date after September 30, 2017."

Additionally, a Locally-Headquartered Business shall mean a Local Business as defined above which has a "principal place of business" in Miami-Dade County. "Principal place of business" means *the nerve center or the center of overall direction, control, and coordination of activities of the bidder*. If the bidder has only one business location, such business location shall be its principal place of business.

- A. If the Low bidder is not a Local Business, then any and all responsive and responsible Local Businesses submitting a price within ten percent of the Low bid, the Low Bidder, and any and all responsive and responsible Locally-Headquartered Businesses submitting a price within fifteen percent of the Low Bid, shall have an opportunity to submit a best and final bid equal to or lower than the Low Bid.
- B. If the Low Bidder is a Local Business which is not a Locally-Headquartered Business, then any and all responsive and responsible Locally-Headquartered Businesses submitting a price within five percent of the Low Bid, and the Low Bidder shall have an opportunity to submit a best and final bid equal to or lower than the Low Bid.

Ties in best and final bid shall be resolved in the following order of priority: Locally-Headquartered Business, Local Business, other business.

4.0 WARTIME VETERAN'S BUSINESS PREFERENCE PROGRAM:

The attention of the Contractor is hereby directed to the requirements of the Wartime Veteran's Business Preference Program: Per Section 2-8.5.1 of the Miami-Dade County Code, a Local Certified Wartime Veteran Business Enterprise that submits a bid for a contract shall receive a bid preference of five percent of the price bid. These preferences will only be used for evaluating and awarding the bids and shall not affect the contract price. However, if a Local Certified Service-Wartime Veteran Business Enterprise is the lowest bidder as a result of a Best and Final Bid (also known as a BAFO), then the price submitted as part of the Best and Final Bid shall be the contract price.

At the time of bid or proposal submission, the firm must affirm in writing its compliance with the certification requirements of Section 295.187 of the Florida Statutes and submit this affirmation and a copy of the actual certification along with the bid or proposal submission.

5.0 ALLOWANCE ACCOUNTS:

A. ***Contingency Allowance*** - A Contingency Allowance Account has been established for the exclusive use of the Department of Transportation and Public Works as a reserve account to cover unforeseeable and unavoidable costs associated with the Work. This Contingency Allowance account shall be calculated at ten percent (10%) of the base bid total for the Work. It is understood that any unspent portion of the contingency allowance account is to remain with the COUNTY.

6.0 INSURANCE REQUIREMENTS:

Contractor shall indemnify and hold harmless the County and its officers, employees, agents and instrumentalities from any and all liability, losses or damages, including attorneys' fees and costs of defense, which the County or its officers, employees, agents or instrumentalities may incur as a result of claims, demands, suits, causes of actions or proceedings of any kind or nature arising out of, relating to or resulting from the performance of this Agreement by the Contractor or its employees, agents, servants, partners principals or subcontractors. Contractor shall pay all claims and losses in connection therewith and shall investigate and defend all claims, suits or actions of any kind or nature in the name of the County, where applicable, including appellate proceedings, and shall pay all costs, judgments, and attorney's fees which may issue thereon. Contractor expressly understands and agrees that any insurance protection required by this Agreement or otherwise provided by Contractor shall in no way limit the responsibility to indemnify, keep and save harmless and defend the County or its officers, employees, agents and instrumentalities as herein provided.

Contractor shall furnish to Miami-Dade County, Risk Management Division 111 NW 1st Street Suite 2340 Miami FL 33128-1987, Certificate(s) of Insurance which indicate that insurance coverage has been obtained which meets the requirements as outlined below:

A. Worker's Compensation Insurance for all employees of the Contractor as required by Florida Statute 440.

- B. Commercial General Liability Insurance in an amount not less than \$1,000,000 per occurrence, and \$2,000,000 in the aggregate, not to exclude coverage for Products and Completed Operations. Miami-Dade County must be shown as an additional insured with respect to this coverage.
- C. Automobile Liability Insurance covering all owned, non-owned and hired vehicles used in connection with the work, in an amount not less than \$1,000,000 combined single limit per occurrence for bodily injury and property damage.

All insurance policies required above shall be issued by companies authorized to do business under the laws of the State of Florida, with the following qualifications:

The company must be rated no less than "A-" as to management, and no less than "Class VII" as to financial strength, by Best's Insurance Guide, published by A.M. Best Company, Oldwick, New Jersey, or its equivalent, subject to the approval of the County Risk Management Division.

or

The company must hold a valid Florida Certificate of Authority as shown in the latest "List of All Insurance Companies Authorized or Approved to Do Business in Florida" issued by the State of Florida Department of Financial Services.

**NOTE: CERTIFICATE HOLDER MUST READ: MIAMI-DADE COUNTY
111 NW 1st STREET
SUITE 2340
MIAMI, FL 33128**

- A. Compliance with the foregoing requirements shall not relieve the vendor of his liability and obligation under this section or under any other section of the Contract.
- B. Contractor's qualification for inclusion in the Contract is contingent upon the receipt of the insurance documents within fifteen (15) calendar days after notification. If the insurance certificate is received within the specified time frame but not in the manner prescribed in this solicitation, the Contractor shall be verbally notified of such deficiency and shall not be placed in an active status until such time as a corrected certificate is submitted to the County. Contractors who are not or do not remain in compliance will be listed as inactive and will not be remain inactive until all such defects are corrected. Any Contractor placed in an inactive status shall lose their current position in the established rotation and will be placed at the back of the current rotation upon correction of the deficiency and return to active status.
- C. The CONTRACTOR shall be responsible for assuring that the insurance certificates required in conjunction with this Section remain in force for the duration of the contractual period including any and all option years that may be granted to the CONTRACTOR in accordance with Section 2.5 of the Special Conditions.

- D. If insurance certificates are scheduled to expire during the contractual period, the CONTRACTOR shall be responsible for submitting new or renewed insurance certificates to the County at a minimum of thirty (30) calendar days in advance of such expiration. In the event that expired certificates are not replaced with new or renewed certificates which cover the contractual period, the County shall place the contractor in an inactive status until such time as the new or renewed certificates are received by the County in the manner prescribed in the solicitation. Any Contractor placed in an inactive status shall lose their current position in the established rotation and will be placed at the back of the current rotation upon correction of the deficiency and return to active status. If the contractor has an open work order or project when the insurance expires, the contractor will be issued a stop work order and be required to correct the deficiency immediately. No additional time will be allowed as a result of the stop work order and liquidated damages will be assessed. If a Payment and Performance Bond is available on the work, the Bondholder will be notified and given the opportunity to complete the work assignment.
- E. The County may, at its sole discretion require additional or supplemental insurance. Such requirements will be stated in any RPQ issued requiring insurance in addition to the requirements stated above.

7.0 PRE-BID MEETING:

A Pre-Bid Meeting will be held as indicated in the Invitation to Bid (ITB)/Request for Price Quotation (RPQ). Please refer to the ITB/RPQ for instructions and additional information.

8.0 CONTRACTOR USE OF PREMISES:

- 8.1 The Contractor's use of the premises is limited to the limits of construction. The Contractor will coordinate all work with the Project Manager and perform work in a manner which allows continuous use of adjoining facilities by DTPW. The Contractor shall maintain safe access to all project areas at all times.
- 8.2 The Contractor shall remain flexible with respect to his work schedule and if the Contractor is delayed due to the non-availability of the project site, his sole remedy for delay shall be limited to a contract time extension only, with no consideration for additional compensation for lost productivity. This remedy for delay (time extension only, no additional compensation) shall also apply to inclement weather conditions.
- 8.3 The Contractor and his subcontractors shall obtain all necessary Permits and provide copies to the Project Manager prior to commencement of work. At the completion of the project, the Contractor shall provide to the Project Manager as-built drawings, all equipment owner's manuals and related documentation provided by the Manufacturers and a copy of the permit(s) with all required inspections signed off.

8.4 The Contractor shall clean the area after each work day. In addition, the contractor shall clean the area, remove materials and equipment that would create a potential hazard to pedestrians and DTPW operations personnel.

9.0 EQUIPMENT:

The contractor will provide equipment of sufficient size and capacity to meet project needs.

10.0 INSPECTIONS/MATERIAL TESTING:

A. **Inspections:** Daily inspections will be performed by the DTPW Representative. Inspections by the DTPW Representative shall not relieve the Contractor of his duties and obligations related to performance and/or quality of the Work.

The Contractor shall coordinate with the DTPW Representative the inspection of all pertinent work activities that may be deemed crucial to the completion of the Project. The pertinent work activities shall be defined by the DTPW Representative prior to installation. The Contractor will be responsible to schedule a meeting with the DTPW Representative to identify the pertinent work activities. Refer to technical specifications/notes provided in the project drawings. Installation Procedures recommended by manufacturer shall be submitted by the Contractor to the DTPW Representative. Contractor to comply with Technical Specifications/Notes provided on the Contract Drawings.

B. **Materials:** As specified in the Scope of Work and Project Schedule of Values.

11.0 MEASUREMENT AND PAYMENT:

The Schedule of Values includes all costs required for the complete construction of the specified unit of work including cost of material, delivery; installation, testing, and labor including social security, insurance, and other required fringe benefits, workmen's compensation insurance, bond premiums, cost of the Inspector General random audits, rental of equipment and machinery, taxes, incidental expenses and supervision.

The Contractor shall be compensated based on percentage of work completed if a lump sum contract or by unit price quantities as agreed upon by the DTPW Representative. The Schedule of Values will be used for payment and negotiation of additions/deletions to scope. DTPW reserves the right to modify/adjust any of the unit item quantities at the same unit rate as specified on the Schedule of Values with no additional adjustment (compensation) for the reduction of work scope.

The Contractor shall comply with Resolution No. R-138-10, which mandates that SBE firms work be identified in the Schedule of Values, if applicable. In accordance with Resolution R-138-10, the Contractor is required as a condition subsequent to award and prior to the issuance of notice to proceed, that the scope of work to be performed by any SBE utilized to satisfy any SBE goal in the contract be separately identified in such schedule of values.

Payment requisitions for the scope of work of such SBE shall be accomplished by statements of completion of the work of the SBE and shall be accompanied by appropriate documentation including invoicing and checks reflecting payment of the SBE for the previous construction draw.

12.0 TIME OF WORK:

Refer to Technical Specification Section 01 11 00 Summary of Work.

13.0 PRE-CONSTRUCTION MEETING:

A Pre-Construction Meeting will be scheduled prior to the NTP date. The DTPW Representative may require the Contractor to submit at the time of the Pre-Construction meeting a Project Schedule, Detailed Schedule of Values, Maintenance of Traffic (MOT) Plan, Shop Drawing Submittal Log, Emergency Contact List, and List of Subcontractors.

14.0 CONSTRUCTION COORDINATION MEETINGS:

The Contractor shall attend Construction Coordination meetings at the site, if required by the DTPW Representative. The DTPW Representative will advise the Contractor of the frequency of the meetings. The meetings shall be attended by the Contractor's representative and the DTPW Representative at a time and location to be determined by the DTPW Representative.

15.0 COMMENCEMENT, PROSECUTION AND COMPLETION OF WORK:

TIME IS OF THE ESSENCE. The work to be performed under this Contract shall commence on the effective date of the Notice-to-Proceed and be completed and released to MDC upon completion of all punch list items within the time specified.

Completion of All Work: The Work must be Substantially Completed within 120 days after the date when the Contract Time commences to run, and all requirements of the Contract Documents completed to the Engineer's satisfaction, including the completion of all punch list items, delivery to the Engineer of all required deliverable, and completion of any remaining Site restoration; and be ready for final payment no later than 150 calendar days after NTP.

16.0 LIQUIDATED DAMAGES:

TIME IS OF THE ESSENCE and completing the work within the specified time is of the utmost importance to MDC. The following liquidated damages rate(s) have been determined based on the best information available at the time of bidding and represent a good faith effort by MDC to quantify the damages that MDC will incur if the contract duration is not achieved. Therefore, for failure to complete the work within the number of days stipulated in the Invitation to Bid, the Contractor and his/her sureties will be assessed Liquidated Damages as follows:

Final Completion

Liquidated Damages shall be assessed in the amount of \$2,042.37, per day for each day of delay, not as a penalty, but as Liquidated Damages for each day or fraction thereof of delay until the Final Completion Date is met, which will be paid to Miami-Dade County by the Contractor.

17.0 METHOD OF AWARD:

Award shall be made to the lowest responsive and responsible bidder. DTPW reserves the right to negotiate additional or deductive services related to this project with the low bidder. DTPW reserves the right to reject all bids if deemed in the best interest of Miami-Dade County.

18.0 PERFORMANCE & PAYMENT BOND:

The Contractor shall provide a Surety Performance and Payment Bond for 100% of the contract amount. NTP shall not be issued and no work shall commence until a fully executed performance bond and required insurance are submitted and approved by Miami-Dade County's Risk Management Division. Failure to provide a Performance & Payment Bond within the time required inclusive of any time extensions granted by DTPW may be considered withdrawal of the bid and forfeiture of the Bid Bond. The Contractor will be reimbursed for the direct (actual) Surety Performance and Payment costs upon presentation of an invoice and paid receipt/cancelled check.

19.0 COLLUSION AFFIDAVIT:

In accordance with Sections 2-8.1.1 and 10-33.1 of the Miami-Dade County Code as amended by Ordinance No. 08-113, bidders/proposers on County contracts are requested to submit the Collusion Affidavit within five (5) days from notification of intent to award.

Failure to provide a Collusion Affidavit within 5 business days after the recommendation to award has been filed with the Clerk of the Board shall be cause for the contractor to forfeit their bid/proposal bond.

NTP shall not be issued and no work shall commence until a fully executed Collusion Affidavit is submitted and approved by DTPW.

20.0 JOB CLEARINGHOUSE:

The Contractor is required to comply with the requirements of Job Clearinghouse Code §2-1701 and Resolution No. R-1395-05 amending Resolution Nos. 1145-99 & 937-98, by making it a mandatory requirement for contractors to post notice through the County's Clearinghouse process of job opportunities made available by construction improvements on County property.

The procedures direct the Contractor to forward a notice of job vacancy(s) created as a result of this construction work to the Director of the Division of Small Business Development (SBD), located at Stephen P. Clark Center, 111 N.W. 1st. Street, Contract Review and Compliance Section, 19th Floor, Miami, Florida, 33128. The job vacancy notice(s) should be delivered within ten (10) working days following award of contract. The SBD Director will in turn distribute said job announcements to all Miami-Dade County facilities participating in the notification requirements of Resolution No. 1395-05. For information regarding the Miami-Dade County's Clearinghouse program, please contact the SBD at (305) 375-3157..

21.0 SCRUTINIZED COMPANIES:

By executing this proposal through a duly authorized representative, the bidder certifies that the bidder is not on the Scrutinized Companies with Activities in Sudan List or the Scrutinized Companies with Activities in the Iran Petroleum Energy Sector List, as those terms are used and defined in sections 287.135 and 215.473 of the Florida Statutes. In the event that the bidder is unable to provide such certification but still seeks to be considered for award of this solicitation, the bidder shall execute the proposal through a duly authorized representative and shall also initial this space: _____. In such event, the bidder shall furnish together with its proposal a duly executed written explanation of the facts supporting any exception to the requirement for certification that it claims under Section 287.135 of the Florida Statutes. The bidder agrees to cooperate fully with the County in any investigation undertaken by the County to determine whether the claimed exception would be applicable. The County shall have the right to terminate any contract resulting from this solicitation for default if the bidder is found to have submitted a false certification or to have been, or is subsequently during the term of the contract, placed on the Scrutinized Companies for Activities in Sudan List or the Scrutinized Companies with Activities in the Iran Petroleum Energy Sector List.

22.0 USER ACCESS PROGRAM:

Pursuant to Miami-Dade County Budget Ordinance No. 03-192, the County's User Access Program (UAP) does not apply for this project.

23.0 CONTRACTOR DUE DILIGENCE AFFIDAVIT:

The attention of the Contractor is hereby directed to the requirements of Resolution R63-14 in that the award of this contract is conditioned on the Contractor providing the County, when required, with a "CONTRACTOR DUE DILIGENCE AFFIDAVIT".

24.0 RESIDENTS FIRST TRAINING AND EMPLOYMENT PROGRAM:

In accordance with Section 2-11.17 of the Code of Miami-Dade County and Implementing Order No. 3-61 (copies attached or online at <http://www.miamidade.gov/smallbusiness/business-development-legislation.asp>), all contractors and subcontractors of any tier on (i) construction contracts valued in excess of \$1,000,000 for the construction, demolition, alteration and/or repair of public buildings or public works, or (ii) contracts or leases valued in excess of \$1,000,000 for privately funded construction, demolition, alteration or repair of buildings or improvements on County-owned land, shall comply with the following:

1. Bidders must:

- a. Submit a completed Responsible Contractor Affidavit (Form RTFE 1) along with the Bid Submittal Package. The Responsible Contractor Affidavit shall verify that (i) prior to working on the project, all persons employed by the contractor on the project to perform construction have completed the OSHA 10 hour safety training course, and (ii) the contractor will make its best reasonable efforts to have fifty-one percent (51%) of all construction labor hours performed by Miami-Dade County residents.
- b. The Contracting Officer shall provide to any contractor who fails to submit a Responsible Contractor Affidavit with its bid or proposal, a written notice that said contractor has forty-eight (48) hours from the time of notification to submit a Responsible Contractor Affidavit or its bid or proposal will be deemed nonresponsive and disqualified.

2. Prior to the issuance of a Notice to Proceed, contractors must also submit: (i) a Construction Workforce Plan (Form RFTE 2) and supporting documentation; (ii) a list of all subcontractors to be used on the project; (iii) a Responsible Subcontractor Affidavit (Form RFTE 1) for each subcontractor; and (iv) a list of all employees currently employed by the contractor.

3. All certified payrolls submitted to the Contracting Officer shall include an OSHA Safety Training Affidavit (Form RFTE 3).

4. Within thirty (30) business days of completion of a project, the contractor must submit a Workforce Performance Report (Form RFTE 4).

5. Any lessee shall include requirements of Section 2-11.7 of the Code of Miami-Dade County and Implementing Order No. 3-61, including the right of the County to access the contractor's and subcontractors' records to verify compliance, in any contract, subcontract, or sublease. Lessee shall be responsible to the County for payment of compliance monitoring costs and any penalties found due.

25.0 EMPLOY MIAMI-DADE PROGRAM:

Except where state or federal laws or regulations mandate to the contrary, all contractors and subcontractors of any tier performing on a County Construction Contract shall satisfy the requirements of this Article.

In accordance with Section 5.02 of the Miami-Dade County Home Rule Amendment and Charter, Section 2-8.1 of the Code of Miami-Dade County, and Administrative Order No. 3-63, all contractors and subcontractors of any tier on (i) construction contracts valued in excess of one million dollars (\$1,000,000) for the construction, demolition, alteration and/or repair of public buildings, or public works; or (ii) contracts or leases valued in excess of one million dollars (\$1,000,000) for privately funded construction, demolition, alteration or repair of buildings, or improvements on County-owned land:

A. The awarded Contractor is hereby notified that the County will consider whether the Contractor made its best reasonable efforts to promote Employ Miami-Dade on this contract, as defined in A.O. 3-63, as part of the County's evaluation and responsibility review of the Contractor for new County contract awards.

1. Referral Procedures:

- I. Career Source South Florida shall compile and maintain the Employ Miami-Dade Register.
- II. The Contractor will notify Career Source South Florida of the vacancy by completing a Job Opening Form on the Employ Miami-Dade website <https://iapps.careersourcesfl.com/employmd/>. The job order must contain a detailed description of the job responsibilities and qualifications.
- III. Career Source South Florida will then provide a list of qualified candidates available to the Contractor with copy to the Compliance Officer.
- IV. Contractor will review the resumes and qualifications of the candidates, conduct interviews with those candidates who satisfy the minimum competency requirements, and make a good faith effort to fill at least 20% of the labor workforce required per Contractor's Construction Workforce Plan from the Employ Miami-Dade Register through Career Source South Florida.
- V. Positions filled from the Employ Miami-Dade Register must be full-time, for at least 120 days, in order to be considered towards attainment of the 20% labor workforce threshold herein.
- VI. If the 20% labor workforce per Contractor's Construction Workforce Plan from Employ Miami-Dade is not met on the contract, the Contractor must provide the Compliance Officer with a detailed explanation of its efforts.
- VII. Career Source South Florida may have funds to pay a portion of the salaries for Employ Miami-Dade participants. It shall be the responsibility of the Contractor to contact Career Source South Florida directly to determine eligibility for, and make

arrangements as applicable with, Career Source South Florida to pay a portion of the salaries for a specified period and/or during on the job training for the Employ Miami-Dade participants employed on the contract.

26.0 SUBCONTRACTOR / SUPPLIER LISTING:

Pursuant to Section 2-8.1 and 10.34 of the Miami-Dade County Code, for contracts valued at \$100,000 or more when subcontractor(s) and/or supplier(s) are utilized, the Prime contractor/vendor/consultant shall report to Miami-Dade County the race, gender, and ethnic origin of all such first tier subcontractor(s) and supplier(s). The paper-based Subcontractor/Supplier Listing that was previously submitted at time of bid submission is no longer being used. The Prime contractor/vendor/consultant shall be required to identify its first tier subcontractor(s)/supplier(s) and provide demographic information for both their firm and each subcontractor/supplier on the contract as soon as reasonably available and in any event prior to final payment under the contract via Miami-Dade County's online Business Management Workforce System (BMWS).

27.0 MONTHLY UTILIZATION REPORTS:

Paper-based Monthly Utilization Reports (MURs) are no longer being accepted for construction, architecture, and engineering projects with measures. Also for architecture and engineering firms, pursuant to Implementing Order 3-39, primes and subconsultants are required to report payments monthly via Miami-Dade County's online Business Management Workforce System (BMWS). "Compliance Audits" will be created in Miami-Dade County's online Business Management Workforce System (BMWS) after Miami-Dade County pays the Prime contractor/vendor/consultant (approximately one month after). Miami-Dade County Departments will check the compliance audit status for each payment application to ensure that no audits are open for more than two (2) months. For construction contracts without measures, which only require reporting of cumulative subcontractor payments, a "Compliance Audit" shall only be verified prior to the final payment.

28.0 PUBLIC RECORDS AND CONTRACTS FOR SERVICES PERFORMED ON BEHALF OF MIAMI-DADE COUNTY (HB 1309):

HB 1309 re: governmental accountability has been signed into law by the Governor and was effective July 1. It generally applies only to state agencies, but there is one provision of HB 1309 that also applies to counties. This provision requires public agency contracts for services performed on behalf of the public agency to contain contract provisions clarifying the public record responsibilities of the contractor.

The Contractor shall comply with the Public Records Laws of the State of Florida, including but not limited to, (1) keeping and maintaining all public records that ordinarily and necessarily would be required by Miami-Dade County (County) in order to perform the service; (2) providing the public with access to public records on the same terms and conditions that the County would provide the records and at a cost that does

not exceed the cost provided in Chapter 119, F.S., or as otherwise provided by law; (3) ensuring that public records that are exempt or confidential and exempt from public records disclosure requirements are not disclosed except as authorized by law; and (4) meeting all requirements for retaining public records and transferring, at no cost, to the County all public records in possession of the Contractor upon termination of the contract and destroying any duplicate public records that are exempt or confidential and exempt from public records disclosure requirements upon such transfer. In addition, all records stored electronically must be provided to the County in a format that is compatible with the information technology systems of the County. Failure to meet any of these provisions or to comply with Florida's Public Records Laws as applicable shall be a material breach of the agreement and shall be enforced in accordance with the terms of the agreement.

IF THE CONTRACTOR HAS QUESTIONS REGARDING THE APPLICATION OF CHAPTER 119, FLORIDA STATUTES, TO THE CONTRACTOR'S DUTY TO PROVIDE PUBLIC RECORDS RELATING TO THIS CONTRACT, CONTACT THE CUSTODIAN OF PUBLIC RECORDS AT (305) 375-5773; ISD-VSS@MIAMIDADE.GOV; 111 NW 1 STREET, SUITE 1300, MIAMI, FLORIDA 33128.

29.0 CONE OF SILENCE

The attention of the Contractor is hereby directed to the requirements of Miami-Dade County Administrative Order No. 3-27 – Cone of Silence.

30.0 BID PROTEST

The attention of the Contractor is hereby directed to the requirements of Miami-Dade County Implementing Order No. 3-21 – Bid Protest and Resolution R-1080-19 which updated the Bid Protest filing fees for contracts set-aside for bidding solely by certified Small Business Enterprises, and other relevant sections.

31.0 PROMPT PAYMENT

The attention of the Contractor is hereby directed to the requirements of Miami-Dade County Administrative Order No. 3-19 – Prompt Payment.

32.0 ASSIGNABILITY/ASSIGNMENT

ASSIGNABILITY - Department of Transportation and Public Works (DTPW) may assign its rights and obligations under the Contract to any successor to the rights and functions of DTW or to any governmental agency to the extent required by applicable laws or governmental regulations or to the extent that DTPW deems necessary or advisable under the circumstances.

ASSIGNMENT - The Contractor shall not assign, transfer, or otherwise dispose of this Contract, including any rights, title or interest therein, or their power to execute such Contract to any person, company or corporation without the prior written consent to DTPW. DTPW's consent for any assignment will not be unreasonably withheld.

33.0 SECTION 20.055 (5)

The contractor/consultant/vendor agrees to comply with s.20.055 (5), Florida Statutes, and to incorporate in all subcontracts the obligation to comply with s.20.055 (5), Florida Statutes.

Section 20.055 (5):

(5) It is the duty of every state officer, employee, agency, special district, board, commission, contractor, and subcontractor to cooperate with the inspector general in any investigation, audit, inspection, review, or hearing pursuant to this section. Beginning July 1, 2015, each contract, bid, proposal, and application or solicitation for a contract shall contain a statement that the corporation, partnership, or person understands and will comply with this subsection.

34.0 ESTIMATED TIME CONTINGENCY

This Contract contains a Contingency Allowance time extension not to exceed ten percent (10%) of the original Contract Duration. Pursuant to a written request by the Contractor for a time extension, that affects the critical path schedule of the Contract or any previously approved changes; written documentation that supports the justification of a time extension, review and concurrence by the COUNTY A/E, a Contract Contingency Allowance Expenditure Authorization will be created for execution by all parties. Once executed the time extension will adjust the scheduled completion date. The cumulative total of all Contingency Allowance time extensions shall not exceed ten percent (10 %) of the original Contract Duration rounded off to the next whole number.

35.0 LCP TRACKER

Refer to the memo dated April 25, 2019 from the Director of Small Business Development Division for Implementation of LCPtracker.

36.0 RESOLUTION NO. 1181-18 / DIRECTIVE NO. 182536

The Contractor is directed to the attached report regarding consideration of Contractor Safety Information as a Part of the Contractor Responsibility Review for Contract Award – Directive No. 182536 and the requirements of Resolution No. 1181-18, applicable to this Project.

Bidders may request a copy of any ordinance, resolution and/or administrative order cited in this bid solicitation, by contacting the Clerk of the Board at 305.375.5126.

37.0 DISCLOSURE OF ALLEGED DISCRIMINATION LAWSUITS

In accord with Resolution No. R-828-19, the County reserves the right to request from any Bidder the disclosure of any lawsuits which include allegations of discrimination in the last ten years prior to date of solicitation, the disposition of such lawsuits, or statement that there are NO such lawsuits.”

38.0 E-VERIFY

By entering the Contract, the Awarded Bidder becomes obligated to comply with the provisions of Section 448.095, Florida Statute, titled "Verification of Employment Eligibility." This includes but is not limited to utilization of the U.S. Department of Homeland Security’s E-Verify System to verify the employment eligibility of all newly hired employees by the Awarded Bidder effective, January 1, 2021, and requiring all Subcontractors to provide an affidavit attesting that the Subcontractor does not employ, contract with, or subcontract with, an unauthorized alien. Failure to comply may lead to termination of this Awarded Bidder, or if a Subcontractor knowingly violates the statute, the subcontract must be terminated immediately. Any challenge to termination under this provision must be filed in the Circuit Court no later than twenty (20) calendar days after the date of termination. If this Contract is terminated for a violation of the statute by the Awarded Bidder, the Awarded Bidder may not be awarded a public contract for a period of one year after the date of termination, and the Awarded Bidder may be liable for any additional costs incurred by the County resulting from the termination of the Contract. Public and private employers must enroll in the E-Verify System (<http://www.uscis.gov/e-verify>) and retain the I-9 Forms for inspection.

38.0 APPLICABLE LEGISLATION

The selected Contractor will be required to abide by all applicable federal, state and local laws and ordinances, as amended. the applicable local laws and ordinances include, but are not limited to:

Florida Statute(s)

- [Section 119.07](#)- Inspection and Copying of Records; Photographing Public Records; Fees; Exemptions.
- [Section 119.0701](#) - Contracts; Public Records
- [Section 287.133](#) - Public Entity Crimes
- [Section 287.135](#) - Prohibition against contracting with scrutinized companies
- [Section 295.187](#) - Florida Veteran Business Enterprise Opportunity Act
- [Section 448.095](#) – Employment Eligibility

Ordinance(s)

- 77-13 - Financial Disclosures Requirements
- 90-133 - Disclosure of Ownership, Collective Bargaining Agreement, and Employee Wages, Health Care Benefits, Race, National Origin and Gender
- [97-35](#) - Policy of Fair Subcontracting Practices
- [97-67](#) - Amending Chapter 11A Prohibiting Discrimination in Contracting, Procurement, Bonding and Financial Services
- [99-152](#) - False Claim Ordinance
- [03-107](#) - Ordinance Amending Section 2-11.1 (s) of the Conflict of Interest and Code of Ethics
- [07-65](#) - Sustainable Buildings Program (when applicable)
- [08-113](#) - Ordinance Amending Sections 2-8.1.1 and 10-33.1 of the Miami-Dade County Code relating to bids from related parties to include a prohibition on collusive bidding
- [11-90](#) - Ordinance Relating to the Collection of Data for a Disparity Study
- [14-79](#) - Sea-Level Rise Ordinance (when applicable)
- [21-22](#) - Buy American Iron and Steel Products Procurement Program

Resolution(s)

- R-1049-93 - Affirmative Action Plan Furtherance and Compliance
- R-385-95 - Policy prohibiting contracts with firms violating the American with Disabilities Act (ADA) and other laws prohibiting discrimination on the basis of disability ADA requirements, are a condition of award, as amended by Resolution R-182-00
- [R-531-00](#) - Prohibition of contracting with individuals and entities while in arrears with the County
- [R-183-00](#) - Family Leave Requirements
- [R-185-00](#) - Domestic Violence Leave
- [R-273-05](#) - Public Involvement Planning
- [R-63-14](#) - Contractor Due Diligence
- [R-828-19](#) – Disclosure of Alleged Discrimination Lawsuits
- [R-1106-15](#) - Aspirational Policy of Miami-Dade County
- [R-1011-15](#): Requiring Vendors to Provide Addresses of Local Offices Administrative Order(s)

Administrative Order(s)

- [03-27](#) - Code of Silence
- [3-53](#) – Miscellaneous Construction Contracts Program
- [10-10](#) - Duties and Responsibilities of County Departments for Compliance with the Americans with Disabilities Act (ADA) Implementing Order(s)
- [3-19](#) – Prompt Payment

Implementing Order(s)

- [3-21](#) - Bid Protest Procedure
- [3-24](#) – Responsible Wages and Benefits for County Construction Contracts
- [3-37](#) – Community Workforce Program
- [3-61](#) – Residents First Training and Employment Program
- [3-63](#) – Employ Miami-Dade Program
- [7-7](#) – Policies and Procedures Establishing a Public Service Honor Code for Elected and Appointed County Officials and County Employees

Miami-Dade County Code(s)

- [Section 2-8.1](#) - Contracts and Purchases
- [Section 2-8.1.5](#) – Nondiscrimination
- [Section 2-8.4](#) - Protest Procedures
- [Section 2-8.5](#) – Procedure to provide preference to local business in county contracts
- [Section 2-8.5.1](#) - Procedure to Provide Preference to Local Certified Veteran Business Enterprises in County Contracts
- [Section 2-8.8](#) - Fair Subcontracting Practices
- [Section 2.11.1](#) - Conflict of Interest and Code of Ethics
- [Section 10-34](#) - Listing of Subcontractors Required
- [Section 2-8.2.6.1](#) - Buy American Iron and Steel Products Procurement Program

39.0 BUY AMERICAN IRON AND STEEL PRODUCTS PROCUREMENT PROGRAM

The attention of the Contractor is hereby directed to the requirements of Miami-Dade County Ordinance No. 21-22 and Miami-Dade County Code 2-8.2.6.1 – Buy American Iron and Steel Products Procurement Program, applicable to this project.

DEPARTMENT OF TRANSPORTATION AND PUBLIC WORKS

BID DOCUMENTS

KITCHEN REMODELING IN THE BREAKROOM OF PALMETTO METRORAIL STATION

PROJECT NO. TP-0000014679

LCP TRACKER

Memorandum



Date: April 25, 2019

To: Department Directors

From: Gary T. Hartfield, Director
Small Business Development (SBD) Division

Subject: Implementation of LCPtracker

A handwritten signature in blue ink, appearing to read "G. Hartfield", written over a light blue grid background.

On April 10, 2018, the Board of County Commissioners adopted Ordinance No. 18-33, which amended several Miami-Dade County Code sections to mandate use of the County's web-based system, the Business Management Workforce System (BMWS), to comply with Small Business Enterprise (SBE), Wage, and Workforce program requirements. The implementation of BMWS will soon be complete with the "go live" of LCPtracker on May 1, 2019.

LCPtracker is a new web-based system for firms to submit certified payroll and workforce program documentation, replacing our current paper-based reporting requirements at no cost to the firms. As part of the implementation of LCPtracker, Small Business Development (SBD), a division of the Internal Services Department, reviewed all active Miami-Dade County contracts in BMWS subject to Responsible Wages and Benefits, Living Wages and federally-funded contracts at Miami Dade County International Airport with Davis Bacon Wages. Based on the contract status, over three hundred existing contracts have been selected to go into LCPtracker. Attached is the latest report listing the projects by department. In addition to these identified projects, all County contracts subject to the above-mentioned wage requirements and awarded on or after April 1, 2019 will be synced to LCPtracker for the electronic submission of certified payrolls and workforce documentation.

Beginning with the May 2019 reporting period, all prime contractors/vendors and their subcontractors at every tier level participating on a contract that was added to LCPtracker must submit certified payrolls via the system by the 10th day of the month for work performed in the previous month. Therefore, all certified payrolls for work performed in the month of May 2019 must be submitted electronically by **June 10, 2019**. At which point, the department should no longer collect or accept paper certified payrolls for these projects.

SBD will provide department staff with access to LCPtracker to view certified payrolls by project, firm, and reporting period. Prior to approving a firm's pay application/invoice, departments must log into LCPtracker to verify certified payrolls have been submitted for all firms on the project, regardless of tier, for the period of the pay application.

Attached are the steps to generate the LCPtracker report titled "Certified Payroll Report (CPR) Status Report" for a project and period of a pay application/invoice under review. This report will list all received, rejected, pending and delinquent certified payrolls for a project for the period requested. For any delinquent certified payrolls listed on the report, the departments should:

- 1) Provide written notice to the prime contractor/vendor (and SBD, if the prime contractor/vendor is a certified SBE or any of the subcontractors are certified) that the review and approval of its pay application/invoice is on hold until all firms that worked during the period of the pay application/invoice have submitted their certified payrolls via LCPtracker.

- 2) Provide the prime contractor/vendor with a copy of the CPR Status Report, or provide the report to the firm(s) listed under the delinquent section of the report, the week ending date for the missing payroll(s), and a deadline to submit the missing certified payroll(s) via LCPtracker.

LCPtracker user accounts for department staff on existing applicable contracts will be automatically created. For any additional staff requiring access, the department's SBD Liaison should provide their name and email address to Alecia Anderson, SBD Section Manager, at Alecia.Anderson@miamidade.gov or Shawn Gannon, Special Projects Administrator, at Shawn.Gannon@miamidade.gov.

As always, SBD will continue to work closely with departments to ensure compliance with the legislated changes and offer monthly hands-on training opportunities for department staff and firms. Should you have any questions, please do not hesitate to contact Alice Hidalgo-Gato, SBD Section Chief, at (305) 375-3153.

Attachments

- c. Office of the Mayor Senior Staff
Tara C. Smith, ISD Director
SBD Liaisons
Procurement Liaisons

DEPARTMENT OF TRANSPORTATION AND PUBLIC WORKS BID DOCUMENTS

KITCHEN REMODELING IN THE BREAKROOM OF PALMETTO METRORAIL STATION

PROJECT NO. TP-0000014679

SAFETY DIRECTIVE 182536 / RESOLUTION NO. 1181-18

Memorandum



Date: February 26, 2019

Agenda Item No. 2(B)2
March 19, 2019

To: Honorable Chairwoman Audrey M. Edmonson
and Members, Board of County Commissioners

From: Carlos A. Gimenez
Mayor

A handwritten signature in blue ink, appearing to read "Carlos A. Gimenez", written over a horizontal line.

Subject: Report Regarding Consideration of Contractor Safety Information as a Part of the
Contractor Responsibility Review for Contract Award – Directive No. 182536

This report is in response to Resolution No. R-1181-18, approved at the November 8, 2018 meeting of the Board of County Commissioners (Board), directing the County Mayor or the County Mayor's designee to provide a status report describing the processes, procedures and actions taken to consider safety records of prospective contractors and first-tier subcontractors for public construction projects.

The County reviews contractor responsibility prior to award for all construction contracts. Pursuant to Resolution No. R-187-12, and in accordance with procurement guidelines, staff currently performs due diligence reviews as a part of the process to determine a contractor's responsibility. This review includes checking the contractor's corporate status, lists for convicted, debarred and suspended vendors, excluded parties, and internal County reports for small business compliance, evaluations and delinquent contractors.

County staff will require contractors and proposed first-tier subcontractors to submit the following items for the previous three years from the United States Department of Labor Occupational and Safety Health Administration (OSHA):

1. The OSHA Form 300 containing a list of the company's work-related injury and illness data; and
2. OSHA inspection data.

A copy of this memorandum and Resolution No. R-1181-18 will be forwarded to each of the department directors who manage capital programs across the County. Confirmation that safety due diligence was performed and any instance when a safety record affects the contractor responsibility will be included in any memorandum to the Board recommending an award or ratification of award of a construction project.

Pursuant to Ordinance No. 14-65, this memorandum will be placed on the next available Board Meeting agenda. Should you require additional information, please contact Tara C. Smith, Director, Internal Services Department, at 305-375-1135.

- c: Abigail Price-Williams, County Attorney
Geri Bonzon-Keenan, First Assistant County Attorney
Office of the Mayor Senior Staff
Tara C. Smith, Director, Internal Services Department
Department Directors
Linda L. Cave, Acting Director, Clerk of the Board
Eugene Love, Agenda Coordinator
Yinka Majekodunmi, Commission Auditor

MEMORANDUM

Agenda Item No. 11(A)(1)

TO: Honorable Chairman Esteban L. Bovo, Jr.
and Members, Board of County Commissioners

DATE: November 8, 2018

FROM: Abigail Price-Williams
County Attorney

SUBJECT: Resolution directing the County Mayor to: (1) consider safety records of prospective contractors and first-tier subcontractors for public construction projects; (2) confirm the safety records of recommended contractors and first-tier subcontractors were considered and report any instance where the safety record may adversely affect a finding of contractor responsibility in award memorandum to the Board; and (3) provide a report to the Board within 60 days

Resolution No. R-1181-18

This item was amended at the 10-17-18 Government Operations Committee to add language in Section 1 specifying that the OSHA related safety information required to be considered in the resolution shall be initially provided by the prospective contractors and first-tier subcontractors bidding on County construction projects.

The accompanying resolution was prepared and placed on the agenda at the request of Prime Sponsor Commissioner Daniella Levine Cava.

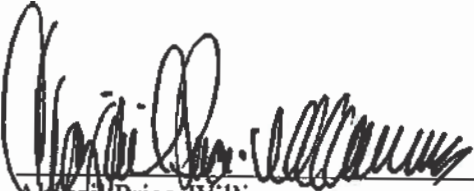
Abigail Price-Williams
County Attorney

APW/lmp



MEMORANDUM

(Revised)

TO: Honorable Chairman Esteban L. Bovo, Jr.
and Members, Board of County Commissioners

DATE: November 8, 2018

FROM: 
Abigail Price-Williams
County Attorney

SUBJECT: Agenda Item No. 11(A)(1)

Please note any items checked.

- "3-Day Rule" for committees applicable if raised**
- 6 weeks required between first reading and public hearing**
- 4 weeks notification to municipal officials required prior to public hearing**
- Decreases revenues or increases expenditures without balancing budget**
- Budget required**
- Statement of fiscal impact required**
- Statement of social equity required**
- Ordinance creating a new board requires detailed County Mayor's report for public hearing**
- No committee review**
- Applicable legislation requires more than a majority vote (i.e., 2/3's ____, 3/5's ____, unanimous ____) to approve**
- Current information regarding funding source, index code and available balance, and available capacity (if debt is contemplated) required**

Approved _____ Mayor
Veto _____
Override _____

Agenda Item No. 11(A)(1)
11-8-18

RESOLUTION NO. R-1181-18

RESOLUTION DIRECTING THE COUNTY MAYOR OR COUNTY MAYOR'S DESIGNEE TO: (1) CONSIDER SAFETY RECORDS OF PROSPECTIVE CONTRACTORS AND FIRST-TIER SUBCONTRACTORS FOR PUBLIC CONSTRUCTION PROJECTS; (2) CONFIRM THE SAFETY RECORDS OF RECOMMENDED CONTRACTORS AND FIRST-TIER SUBCONTRACTORS WERE CONSIDERED AND REPORT ANY INSTANCE WHERE THE SAFETY RECORD MAY ADVERSELY AFFECT A FINDING OF CONTRACTOR RESPONSIBILITY IN AWARD MEMORANDUM TO THE BOARD; AND (3) PROVIDE A REPORT TO THE BOARD WITHIN 60 DAYS

WHEREAS, we live in a large, heavily-populated and diverse metropolitan area with constantly expanding public infrastructure needs and demands; and

WHEREAS, Miami-Dade County's infrastructure, including its public buildings, roads and bridges, mass transit facilities, airports and seaport, fuel supply facilities, medical and nursing care facilities, recreational facilities, sporting facilities and water and wastewater facilities, constantly require significant new construction and on-going improvements and upgrades; and

WHEREAS, consequently, to meet these infrastructure demands, Miami-Dade County (the "County") enters into significant construction contracts for public buildings, structures and other public works; and

WHEREAS, a substantial number of the County's public construction projects are large complex projects requiring a large of number of workers to complete the project; and

WHEREAS, many of these County projects occur in densely populated areas where members of the public may be directly exposed to the dangers of a construction site; and

WHEREAS, the tragic loss of life caused by the collapse of the Florida International University pedestrian bridge reminds this community that the safety of members of the public and workers relating to public construction projects is of paramount importance; and

WHEREAS, this Board wants to ensure that a contractor's safety record be fully considered in the selection and contracting of construction companies for public infrastructure projects,

NOW, THEREFORE, BE IT RESOLVED BY THE BOARD OF COUNTY COMMISSIONERS OF MIAMI-DADE COUNTY, FLORIDA, that this Board:

Section 1. Directs the County Mayor or County Mayor's designee to consider the safety records of prospective contractors and their first-tier subcontractors as part of the due diligence investigation performed to determine contractor responsibility for the construction or improvement of a public building, structure or other public construction project that will be presented to this Board for contract award or ratification of an award. Such investigation shall include reviewing available relevant information from the United States Department of Labor Occupational Safety and Health Administration (OSHA) such as OSHA logs of work-related injuries and illnesses (Form 300) and OSHA inspection data >>which shall be initially provided by the prospective contractors and first-tier subcontractors<<¹. The OSHA information shall be reviewed for at least the previous three (3) years to the extent that such information is available for that period. In addition, County staff may use other sources to investigate the safety records

¹ Committee amendments are indicated as follows: Words stricken through and/or [[double bracketed]] are deleted, words underscored and/or >>double arrowed<< are added.

of prospective contractors and their first-tier subcontractors for public construction projects in determining contractor responsibility.

Section 2. Directs the County Mayor or County Mayor’s designee to include in his or her memorandum to this Board recommending an award or ratification of an award of a County public construction project confirmation that the safety record was considered by the County as part of the due diligence required pursuant to Resolution R-187-12, including reporting to this Board any instance where the safety record may adversely affect a finding of contractor responsibility.

Section 3. Directs the County Mayor or County Mayor’s designee to submit a report to this Board within 60 days of the effective date of this resolution describing the processes, procedures and actions taken to comply with Sections 1 and 2 of this resolution and place the completed report on an agenda of the Board pursuant to Ordinance No. 14-65.

The Prime Sponsor of the foregoing resolution is Commissioner Daniella Levine Cava. It was offered by Commissioner **Dennis C. Moss**, who moved its adoption. The motion was seconded by Commissioner **Sally A. Heyman** and upon being put to a vote, the vote was as follows:

	Esteban L. Bovo, Jr., Chairman	aye	
	Audrey M. Edmonson, Vice Chairwoman	aye	
Daniella Levine Cava	aye	Jose "Pepe" Diaz	aye
Sally A. Heyman	aye	Eileen Higgins	aye
Barbara J. Jordan	aye	Joe A. Martinez	aye
Jean Monestime	aye	Dennis C. Moss	aye
Rebeca Sosa	aye	Sen. Javier D. Souto	aye
Xavier L. Suarez	aye		

The Chairperson thereupon declared this resolution duly passed and adopted this 8th day of November, 2018. This resolution shall become effective upon the earlier of (1) 10 days after the date of its adoption unless vetoed by the County Mayor, and if vetoed, shall become effective only upon an override by this Board, or (2) approval by the County Mayor of this resolution and the filing of this approval with the Clerk of the Board.



MIAMI-DADE COUNTY, FLORIDA
BY ITS BOARD OF
COUNTY COMMISSIONERS

HARVEY RUVIN, CLERK

Linda L. Cave

By: _____
Deputy Clerk

Approved by County Attorney as
to form and legal sufficiency.

A handwritten signature in black ink, appearing to read "E. Gonzalez", is written over a horizontal line.

Eduardo W. Gonzalez

A handwritten mark or signature, possibly a stylized "4" or a similar symbol, is located at the bottom center of the page.

DEPARTMENT OF TRANSPORTATION AND PUBLIC WORKS

BID DOCUMENTS

KITCHEN REMODELING IN THE BREAKROOM OF PALMETTO METRORAIL STATION

METROMOVER MAINTENANCE FACILITY

RPQ NO. 14679

STANDARD CONSTRUCTION
GENERAL CONTRACT CONDITIONS

STANDARD CONSTRUCTION
GENERAL CONTRACT CONDITIONS
TABLE OF CONTENTS

Article

1. DEFINITIONS
2. INTERPRETATION
3. ARCHITECT/ENGINEER
4. OWNER
5. CONTRACTOR
6. SUBCONTRACTORS
7. PROSECUTION OF THE WORK
 - A. Workmanship and Unauthorized Work
 - B. Material
 - C. Methods of Sampling and Testing
 - D. Meetings
 - E. Permits and Compliance with Laws
 - F. Coordination and Access
 - G. Rights in Land and Improvements
 - H. Interference with Existing Utilities
 - I. Protection of Existing Facilities, Vegetation, Structures, Utilities and Improvements
 - J. Damage to the Work and Responsibility for Materials
 - K. Emergencies
 - L. Accident Prevention
 - M. Warranty of Work
8. CONTRACT TIME
 - A. Notice to Proceed
 - B. Schedules
 - C. Extensions of Time and Classification of Types of Delays
 - D. Substantial Completion and Final Acceptance
 - E. Use and Possession
 - F. Liquidated Damages/Liquidated Indirect Costs
9. PROGRESS PAYMENTS
 - A. Payments
 - B. Taxes
 - C. Payments to Subcontractors and Suppliers
 - D. Contract Prices - Bid Form

E. Final Payment

10. CHANGES

- A. Changes
- B. Allowance Accounts
- C. Deletion or Addition of Work
- D. Increased or Decreased Quantities (Unit Prices)
- E. Extra Work
- F. Differing Site Conditions
- G. Force Account
- H. Contractor Proposals - General
- I. Value Engineering Change Proposals

11. CLAIMS AND DISPUTES

- A. Notice of Claims
- B. Claim Submittals
- C. Disputes
- D. Termination

12. MISCELLANEOUS PROVISIONS

- A. No Third Party Beneficiary
- B. Venue
- C. Governing Laws
- D. Successors and Assigns
- E. Written Notice
- F. Indemnification
- G. Audit Rights
- H. Severability
- I. Payment and Performance Bonds
- J. Insurance
- K. Conflict of Interest
- L. Rights in Shop Drawings
- M. Patent and Copyright
- N. Historical, Scientific and Archaeological Discoveries
- O. Use of Owner's Name in Contractor Advertising or Public Relations

13. ATTACHMENTS

1. DEFINITIONS

(June 12, 2012)

Addendum/Addenda: A modification or clarification of the Contract Documents distributed to prospective Bidders prior to the opening of Bids.

Advertisement for Bids: The public notice inviting the submission of Bids for the Work.

Allowance Account (General): Account in which a stated maximum dollar amount is included in the Contract for the purpose of funding, at the sole discretion of the Owner, unforeseen and/or changed conditions or extra work arising during the prosecution of the Work or any other changes issued by the Owner. The scope and limitations regarding use of the Allowance Account are contained in the Contract Documents. Performance of work, if any, under this Allowance Account shall be authorized by written Work Order issued by the Owner.

Allowance Account(s) (Dedicated): Account(s) in which stated maximum dollar amount(s) are included in the Contract for the purpose of funding specific items of work at the sole discretion of the Owner. The scope and limitations regarding use of the Dedicated Allowance Account(s) are contained in the Contract Documents.

Architect/Engineer: Owner or its authorized representatives identified in the Notice-to-Proceed letter, including but not limited to the Resident Architect/Engineer, the Construction Manager, the Owner's representatives and the Architect/Engineer of Record. In the event an Architect/Engineer is not employed on the project, the term "Owner" may be substituted for Architect/Engineer.

Art in Public Places: Miami-Dade County program established through Ordinance #94-12 and codified in Miami-Dade County Code Section 2-11.15 providing 1.5% of each County project's capital cost to fund a public art component within the Project. Coordination and installation of the Artist's work is included as part of the scope of the Contractor's services to the extent that it is defined in the Bid Documents.

Artist: Person(s) chosen through the Art in Public Places program to design and fabricate or specify an integrated work of art for the Project. The term Artist as may be referred to in the Contract Documents means the Artist and/or their authorized representative.

As-Built Documents: Documents signed and sealed by an appropriately licensed professional and submitted by the Contractor during and/or upon completion of the Contract reflecting actual installed/built conditions and all changes made in the Contract Documents during the construction process and showing the exact dimensions, geometry, location, identification and such other information as required by the Contract Documents and/or Architect/Engineer for all elements of the work completed under the contract. (Also referred to as As-Built Drawings or As-Built). Final payment is conditional upon the receipt of As-Built Documents.

BCC: Board of County Commissioners, the governing board of Miami-Dade County.

Beneficial Occupancy: The point at which the Owner or Architect/Engineer determines that the Work or any portion thereof can be occupied from a regulatory and work function

standpoint prior to Substantial Completion of the Work. Beneficial Occupancy will not relieve the Contractor of any of its obligations relative to Substantial Completion or of its responsibility to fully complete the Work in accordance with the Contract Documents.

Bid: The written offer of a Bidder to perform the Work.

Bid Documents: The Advertisement for Bids, Instructions to Bidders, Bid Form, Bid Security, Construction Contract, all contractual forms, General Conditions, Special Provisions, Technical Specifications and Contract Drawings, together with all Addenda and any other applicable standards, regulations, laws and permits as described within these other documents which may be incorporated by reference.

Bid Item: A specific item of work represented by a line item in the Bid Form.

Bid Form: The form on which Bids are submitted.

Bid Security: The cashier's check, certified check or bid bond, accompanying the Bid and submitted by the prospective bidder, as a guarantee that the prospective bidder will enter into a contract with the Owner for the performance of the Work and furnish acceptable bonds and insurance if the Contract is awarded to him.

Bidder: An individual, firm, partnership, corporation or combination thereof, submitting a Bid for the Work.

Certificate of Substantial Completion: Certificate issued to the Contractor by the Owner certifying that Substantial Completion has been achieved.

Certificate of Completion: Certificate issued by the local building official providing proof that a structure or system is complete and, for certain types of permits, is released for use and may be connected to a utility system. This certificate does not grant authority to occupy a building, such as a shell building, prior to the issuance of a Certificate of Occupancy by the local building official.

Certificate of Final Acceptance: Certificate issued to the Contractor by the Owner certifying that Final Acceptance has been achieved in accordance with the definition reflected herein (see Final Acceptance definition).

Certificate of Occupancy: Certificate issued by the local building official after the building official inspects the building or structure and finds no violations of the provisions of applicable codes or other laws that are enforced by the local building department.

Change Notice: A document issued by the Architect/Engineer or Owner to the Contractor specifying a proposed change to the Contract Documents and requesting a price proposal from the Contractor, if applicable, within a specified time period.

Change Order: A written agreement executed by the Owner, the Contractor and the Contractor's Surety, covering modifications to the Contract Documents.

Construction Staging Area: Property which may be available for use by the Contractor during the construction period for the purpose of storing products and construction equipment and for the purpose of staging the Work. The construction staging area(s), if applicable, are defined in the Contract Documents.

Construction Contract: The agreement executed by the Contractor and the Owner covering the performance of the Work including the furnishing of labor, superintendence, materials, tools and equipment as indicated in the Contract Documents. The term “Contract” shall have the same meaning.

Consultant: See Architect/Engineer.

Contract Documents: Bid Documents, Change Orders, Payment and Performance Bonds, Work Orders, Approved Schedules, all Contractual Forms, Approved Shop Drawings and Approved Working Drawings.

Contract Drawings: The plans, profiles, cross-sections, elevations, schedules, and details which show locations, character, dimensions and details of the Work. Contract Drawings are confidential under the Florida Public Records Act and the Contractor is responsible for maintaining confidentiality during and after the progress of the Work.

Contractor: The individual, firm, partnership, or corporation, or combination thereof, private, municipal, or public, including joint ventures, duly licensed under Florida Statutes, which, as an independent Contractor, has entered into a Contract with Miami-Dade County, who is referred to throughout the Contract Documents by singular in number and masculine in gender.

Contract Time: The number of days allowed for completion of the Work commencing with the effective date of Notice to Proceed. The Contract Time will be stipulated in the Contract Documents unless extended by a Change Order or by a Work Order.

County: See Owner.

County Manager: The County Manager of Miami-Dade County, Florida.

County Mayor: The Mayor of Miami-Dade County, Florida.

Critical Path: Longest sequence of activities in a project’s schedule which defines the project completion date and which must be completed on time in order for the project to be completed on schedule.

Days: Unless otherwise designated, days mean calendar days.

Department Director: The Director of the Miami-Dade County Department implementing the work.

Department Director’s Representative: The person or persons designated by the Department Director to act on his behalf in the administration of the contract within the limits of their respective authorization.

Direct Costs: Direct Costs recoverable by the Contractor as a result of changes in the Work shall be limited to the actual additional costs of labor and materials installed as part of the Work and for the reasonable additional cost of rental of any Special Equipment or Machinery. Labor shall be limited to site labor costs, including Employer’s Payroll Burden. Specifically excluded from labor are the costs of general foremen and site office personnel. Materials are limited to permanent materials required by the Contract Documents and materials approved by the Architect/Engineer as necessary to install the permanent materials in an efficient and workmanlike manner. For special equipment or machinery not listed in said document, the Contractor shall be paid a rental rate corresponding to the average

prevailing rental rate for such equipment or machinery in Miami-Dade County, Florida, subject to approval by the Architect/Engineer. No additional payment shall be made to the Contractor for fuel, lubricants, fair wear and tear, transportation, insurance or depreciation. Any equipment or machinery not designated by the Architect/Engineer as special equipment and machinery shall be considered Overhead.

Extra Work: Work not provided for in the Contract Documents as awarded or as previously modified by Change Order or Work Order but found to be essential to the satisfactory completion of the Contract within its intended scope.

Field Representative/Construction Manager: An authorized representative of the Owner that may provide administrative and construction inspection services during the pre-construction, construction, and closeout phases of the Contract and through which the orders of the Owner shall be given. The Field Representative has no authority to modify or waive any provision of the Contract Documents.

Final Acceptance: The formal written acceptance by the Owner of the completed work.

Final Completion: Point in time when the Owner determines that all Work has been completed in accordance with the Contract Documents and all deficiencies listed within the Certificate of Substantial Completion and Punch List have been corrected to the satisfaction of the Owner or Architect/Engineer including but not limited to all required final inspections, close-out documents, delivery of all spares and extra materials and activation of warranties as required. A Certificate of Final Acceptance shall be issued to the Contractor by the Owner upon Final Completion.

Force Account: A method of payment measured by actual cost of the labor, materials and equipment plus a mark-up for Indirect Costs, as distinct from other payment methods such as lump sum or unit price, for Extra Work ordered by Change Order and/or Work Order.

Fragment: A fragment or selected portion of the Schedule network and/or network of proposed changed work activities.

Furnishing: Manufacturing, fabricating and delivering to the site of the Work materials, plant, power, tools, patterns, supplies, appliances, vehicles and conveyances necessary or required for the completion of Work.

General Conditions: This section of the Contract Documents which specifies, in general, the contractual conditions.

Green Building Practices: Environmentally- and socially-conscious practices that emphasize processes and methods of design and construction that reduce exposure to noxious materials, conserve non-renewable energy and scarce materials, minimize life-cycle ecological impact of energy and materials, employ renewable energy or materials that are sustainably harvested, protect and restore local air, water, soils, flora and fauna, and support pedestrians, bicycles, mass transit and other alternatives to fossil-fueled vehicles.

Indirect Costs: Overhead.

Installation, Install or Installing: Completely assembling, erecting and connecting material, parts, components, supplies and related equipment specified or required for the completion of the Work including the successful passing of all tests so that they are fully functional.

LEED (Leadership in Energy and Environmental Design): An ecology-oriented building certification program run under the auspices of the U.S. Green Building Council (USGBC) which concentrates its efforts on improving performance across five key areas of environmental and human health: energy efficiency, indoor environmental quality, materials selection, sustainable site development, and water savings.

Limit of Work: Boundary within which the Work is to be performed.

Liquidated Damages: The amount that the Contractor accepts, as stipulated in the Contract Documents, that will be deducted from the Contract Sum for each Day of delay due to a Non-excusable Delay.

Liquidated Indirect Costs Rate: The amount, stipulated in the Contract Documents, that will be added to the Contract Sum for each Day of delay due to a Compensable Delay. The Contractor accepts this sum as full compensation for the Contractor's and all its Subcontractors' Indirect Costs, for each Day of Compensable Delays. This amount is agreed to include any costs other than Direct Costs incurred by the Contractor and all its Subcontractors of any tier in the performance of this Contract.

Lump Sum Bid Item: A bid item in which quantity is not separately measured for payment in units but rather is based on the amount bid by the Contractor as indicated in the Bid Form and made a part of the Contract. Partial payments of Lump Sum Bid Items will be conditionally made, based upon an approved schedule of values, and will be subject to reconciliation in the event that the work of a Lump Sum Bid Item is not fully completed in accordance with the requirements of the Contract Documents.

Miami-Dade County (MDC): A political subdivision of the State of Florida, the Owner.

Milestone: A completion date as defined in the Contract Documents.

Notice to Proceed: Written notice from the Owner to the Contractor specifying the date on which the Contractor is to proceed with the Work and on which the Contract Time commences to run.

Notice of Termination: Written notice from the Architect/Engineer or the Owner to the Contractor to permanently stop work under the Contract on the date and to the extent specified in the notice. The Notice of Termination includes Notices of Termination for Convenience, Default and National Emergencies as set forth in the Contract Documents. Upon receipt of such notice, the Contractor shall comply with the termination provisions of this Contract.

Overhead (Indirect Costs): Overhead, also defined as "Indirect Costs", includes any and all costs other than Direct Costs. The term "Overhead" as indicated in this definition shall apply to both Contractors and Subcontractors of any tier. Overhead includes, but is not limited to, all profit and costs associated with: Project bond premiums, Project insurance premiums, costs of supervision, coordination, superintendents, general foremen, consultants, schedulers, cost controllers, accountants, office administrative personnel, time keepers, clerks, secretaries, watch persons, small tools, equipment or machinery, utilities, rent, telephones, facsimile machines, computers, word processors, printers, plotters, computer software, all expendable items, job site and general office expenses, extended jobsite general conditions, interest on monies retained by the Owner, escalated costs of materials and labor, impact cost on unchanged work, inefficiency, decreased productivity, home office expenses or any cost

incurred that may be allocated from the headquarters of the Contractor or any of its Subcontractors, loss of any anticipated profits, loss of bonding capacity or capability losses, loss of business opportunities, loss of productivity on this or any other Project, loss of interest income on funds not paid, costs to prepare a bid, cost to prepare a quote for a Change in the Work, costs to prepare, negotiate or prosecute claims, costs of legal and accounting work, costs spent to achieve compliance with applicable laws and ordinances, loss of Projects not bid upon, loss of productivity or inefficiencies in the Work from any cause.

Owner: Miami-Dade County, whose governing body is the BCC acting in its proprietary capacity. Where applicable, the Owner acts through its Architect/Engineer or Field Representative. When these Contract Documents require the action of individual persons, the documents contain specific references to these persons. In particular, the documents shall refer to the BCC when approval of the BCC is specifically required and to the Architect/Engineer when the Architect/Engineer's approval is specifically required.

Payment and Performance Bonds: Bonds executed by the Contractor and its Surety assuring that the Contractor will, in good faith, perform and guarantee the work in full conformity with the terms of the Contract Documents and will promptly pay all persons supplying the Contractor with labor, materials, or supplies, used directly or indirectly by the Contractor in the prosecution of the Work. These bonds shall be two separate bonds, one bonding payment and one bonding performance. Each bond shall be for no less than 100% of the total maximum contract amount.

Project: See definition for Work.

Punch List: A list issued by the Owner to the Contractor of work elements requiring remedial action or completion by the Contractor before Final Completion is issued to the Contractor.

Right-of-Way: A term denoting land and property, and interests therein, owned or acquired by the Owner.

Schedules: All schedules delivered under the Contract including time schedules and schedule of values.

Schedule of Values: A detailed cost breakdown of each lump sum bid item in the bid form, submitted by the Contractor at the beginning of the Work and to be used as a basis to determine monthly progress payments and quantity adjustments within the constraints specified in the Contract Documents.

Shop Drawings: Documents furnished by the Contractor for approval by the Architect/Engineer to illustrate specific portions of the Work. Shop Drawings include drawings, diagrams, illustrations, calculations, schedules, tables, charts, brochures and other data describing design, fabrication and installation of specific portions of the Work.

Site, Project Site, Work Site, Construction Site, Job Site: The location(s) at which the work under this Contract is to be accomplished, as shown in the Contract Documents.

Special Provisions: Section of the Contract which includes specific contractual requirements not covered in the General Conditions that are specific to the Project.

Subcontractor: Any person or entity, other than the employees of the Contractor, supplying the Contractor with labor, materials, supplies and/or equipment used directly or indirectly by the Contractor in the prosecution of the Work.

Substantial Completion: Substantial Completion of a Project is the date on which the Owner certifies that the construction is sufficiently completed, in accordance with the Contract Documents, as modified by any Change Orders, so that the Owner can occupy the Project for the use for which it was intended. A certificate shall be issued to the Contractor by the Owner upon achievement of Substantial Completion.

Surety: The bonding company or companies furnishing the bonds required of a Bidder and of the Contractor.

Technical Specifications: The general term comprising all the written directions, provisions and requirements contained herein, entitled "Technical Specifications," those portions of standard specifications to which reference is specifically made in the Technical Specifications, and any Addenda, Work Orders and Change Orders that may be issued for the Contract, all describing the work required to be performed, including detailed technical requirements as to labor, materials, supplies and equipment and standards to which such work is to be performed as well as any reports specifically issued with the Bid Documents and specifically identified in the Instructions to Bidders which may include geotechnical or other technical reports.

Temporary Construction Easement Line: A boundary which describes additional areas which may be made temporarily available for construction operations.

Time Contingency: The maximum time specifically identified in the Contract Documents by which the Owner may extend the contract time to accomplish the work without a change order. Limitations on the use of the time contingency are set forth in the Contract Documents.

Unit Prices: Unit prices shall include all labor, materials, tools, and equipment; all other direct and indirect costs necessary to complete the item of Work and to coordinate the unit price Work with adjacent work; and shall include all overhead and profit. Contractor shall accept compensation computed in accordance with the unit prices as full compensation for furnishing such Work.

Work: The construction and services required by the Contract Documents, which includes all labor, materials, equipment, and services to be provided by the Contractor to fulfill the Contractor's duties and obligations imposed by the Contract Documents or, if not specifically imposed by the Contract Documents, which can be reasonably assumed as necessary to fulfill the intent of the Contract Documents to provide a complete, fully functional and satisfactory project.

Work Order: A written order, authorized by the Architect/Engineer or Owner, directing the Contractor to perform work under a specific Allowance Account or directing the Contractor to perform a change in the Work that does not have a monetary impact, including but not limited to, extending the Contract Time or subject to the payment of Liquidated Indirect Costs if entitlement is established as required by these Contract Documents. No Work Order may increase the Contract Sum.

END OF ARTICLE

2. INTERPRETATION

(June 12, 2012)

- A. The intent of the Contract is to include all necessary items for the proper completion of the Work by the Contractor so the Owner may have a fully functioning facility and fully receive the benefits intended under the Contract. The Contractor shall perform, without additional compensation, such incidental work as necessary to complete the Work and fulfill the design intent, in accordance with the requirements set forth in the Contract Documents, so that it will meet the requirements for which the Project was intended, in a satisfactory and workmanlike manner.
- B. The Contract Documents and all referenced standards cited are essential parts of the Contract requirements. A requirement occurring in one is as binding as though occurring in all. The documents comprising the Contract Documents are complementary and indicate the construction and completion of the Work. Anything mentioned in the Contract Documents and not shown on the Contract Drawings or shown on the Contract Drawings and not mentioned in the Contract Documents, shall be of like effect as if shown or mentioned in both. The more stringent shall apply in the case of a conflict.
- C. Site Inspections and Verification of Governing Dimensions: In executing the contract, the Contractor represents that he has, prior to bid, visited the site, become familiar with the conditions under which the work is to be performed and correlated his personal observations with the requirements of the Contract Documents or that he has chosen not to do so, in the event that a mandatory site visit is not specified in the Contract Documents. The Contractor accepts the responsibility for all errors in construction which could have been avoided by such examination and the opportunity to seek timely clarifications during the bidding process. The Contractor, before commencing work, shall verify all governing dimensions at the site, and shall examine all adjoining work on which his work is in any way dependent for its conformance with the intent of the Contract Documents and no disclaimer of responsibility for defective or non-conforming adjoining work will be considered unless notice of same has been filed by the Contractor, and agreed to in writing by the Owner through the Architect/Engineer before the Contractor begins any part of the Work. No disclaimer for defective or non-conforming adjoining work that was clearly foreseeable to the Contractor during a site visit (mandatory or non-mandatory) will be considered by the Owner.
- D. Errors, Inconsistencies and Omissions: The Contractor shall carefully study and compare all drawings, Contract Documents and other instructions; shall verify all figures on the Contract Drawings before laying out the Work; shall notify the Owner or Architect/Engineer of all errors, inconsistencies, or omissions which he may discover; and obtain specific instructions in writing during the bidding process and prior to submitting his Bid. The Contractor shall not take advantage of any apparent error or omission which may be found in the Contract Drawings or Contract Documents, and the Architect/Engineer shall be entitled to make such corrections

therein and interpretations thereof as he may deem necessary for the fulfillment of their intent. The Contractor shall be responsible for all errors in construction which could have been avoided by such examination and notification, and shall correct, at his own expense, all work improperly priced, scheduled or constructed through failure to notify the Owner or Architect/Engineer and to request specific instructions.

- E. Where "as indicated", "as detailed", or words of similar import are used, it shall be understood that the reference is made to the Contract Documents unless stated otherwise.
- F. References to Articles or Sections include sub-articles or subsections under the Article referenced.
- G. Referenced Standards: Material and workmanship specified by the number, symbol, or title of a referenced standard shall comply with the latest edition or revision thereof and amendments and supplements thereto in effect on the date of the Invitation to Bid except where otherwise expressly indicated. In case of a conflict between the Contract Documents and the referenced standard, the Contract Documents shall govern.
- H. Order of Precedence of Contract Documents: Unless otherwise provided for in the Special Provisions or required by law, the order of precedence of the Contract Documents will be as follows:
 - 1) Change Orders to the Contract
 - 2) Notice to Proceed
 - 3) Construction Contract
 - 4) Addenda
 - 5) Special Provisions
 - 6) General Conditions
 - 7) Technical Specifications
 - 8) Contract Drawings
 - 9) Referenced Codes and Standards
 - 10) Guarantees
 - 11) Instructions to Bidders
 - 12) Invitation to Bid
 - 13) Other documents
- I. In case of differences between small and large scale drawings, the drawings showing greater detail shall govern. Schedules on drawings shall take precedence over conflicting notations on drawings. In the event of discrepancy between any scaled dimensions on drawings and the figures written thereon, the figures shall govern over the scaled dimensions unless otherwise indicated.
- J. Explanations: Should it appear that the Work to be done or any of the matters relative thereto are not sufficiently detailed or explained in the Contract Documents, the Contractor shall apply to the Owner or Architect/Engineer in a timely manner to allow sufficient time for such further written explanations as may be necessary and shall

conform to the explanation provided as part of the Contract. The Owner or Architect/Engineer's decision shall be final.

- K. Effect of Headings: The headings and titles to provisions in the Contract Documents are descriptive only and shall be deemed not to modify or affect the rights and duties of parties to this Contract.
- L. No acceptance, order, measurement, payment, or certificate of or by the Architect/Engineer and/or the Owner or its employees or agents shall either estop the Owner from asserting any rights or operate as a waiver of any provision hereof or of any power or right herein reserved to the Owner or of any rights to damages herein provided.
- M. Wherever the terms, "as directed", "ordered", "permitted", "designated", "as approved", "approved equal", "or equal", "acceptable" and other words of similar meaning which authorize an exercise of judgment are used in the Contract Documents, such judgment shall be vested only in the Architect/Engineer and/or the Owner and shall be final.
- N. The Contractor shall make available at the job site one copy of each referenced standard and/or Contract Documents for the Contractor's and the Field Representative's use during the time that work covered by the standards and/or Contract Documents is underway.
- O. The Contract Documents provide for a complete work and may have been prepared in divisions of various crafts, trades and other categories of work. The Contractor is responsible for the performance of all work under the Contract regardless of any such divisions and shall ensure that all of the work is performed and completed. The organization of the Contract Documents into divisions, sections and articles and the arrangement of the drawings do not restrict or limit the Contractor into dividing the Work among subcontractors or in establishing the extent of the Work to be performed by any trade.
- P. No deviation from the approved Contract Documents shall be permitted without the prior written approval of the Owner, which approved deviation shall be documented either by Change order or Work Order.
- Q. All Requests for Information by the Contractor per this section shall be in accordance with the Contract Documents.

END OF ARTICLE

3. ARCHITECT/ENGINEER/FIELD REPRESENTATIVE

(June 12, 2012)

- A. The Architect/Engineer shall respond to questions which may arise as to the quality and acceptability of materials furnished, work performed, and as to the manner of performance and rate of progress of the work in accordance with the time frames prescribed in the Contract Documents. The Architect/Engineer shall decide all questions which may arise as to the interpretation of the Contract Documents relating to the Work, and the fulfillment of the Contract on the part of the Contractor, and those decisions shall be binding on the Contractor
- B. The Architect/Engineer is not authorized to revoke, alter, or waive any requirement of the Contract.
- C. The Architect/Engineer, Owner or Field Representative shall have free access to the Work and materials at all times to facilitate the performance of his duties.
- D. Subject to concurrence by the Owner, the Architect/Engineer shall have the right to observe and reject any material or work performed which does not meet the requirements of the Contract Documents. When the Architect/Engineer discovers any work in progress or completed that does not meet the requirements of the Contract Documents, the Architect/Engineer shall reject that portion of the Work affected and shall confirm such rejection in writing, as soon as practical, detailing the reasons for the rejection. Work rejected by the Architect/Engineer will not be paid for. Any such observation and/or rejection shall not be construed as undertaking supervisory control of the Work or of means and methods employed by the Contractor or his Subcontractors and shall not relieve the Contractor of any of his responsibilities or obligations under the Contract. The Contractor shall not request or attempt to require the Architect/Engineer to undertake such supervisory control or to administer, supervise, inspect, assist, or act in any manner so as to relieve the Contractor from such responsibilities or obligations.
- E. The fact that the Architect/Engineer has not made early discovery of materials furnished or work performed which does not meet the requirements of the Contract Documents, shall not bar the Architect/Engineer from subsequently rejecting said materials or work.
- F. If either the Architect/Engineer or the Field Representative requests it, the Contractor, at any time before acceptance of the work, shall remove or uncover such portions of the finished work as may be directed. After examination, the Contractor shall restore said portions of the work to the standard required by the Contract Documents. Should the work thus exposed or examined prove acceptable, the uncovering, or removing, and the replacing of the covering or making good of the parts removed will be paid for as Extra Work. Should the work so exposed or examined prove unacceptable, the uncovering, or removing, and the replacing of the covering or making good of the parts removed will be at no additional cost to the Owner.

- G. Any work done or materials used which are not in compliance with the Contract Documents may be ordered removed and replaced at the Contractor's expense.
- H. The Owner and other agencies having jurisdiction over the work hereunder shall be afforded free access to the site to perform such inspections and tests as may be required to determine conformance of the Work with the Contract Documents.
- I. Neither the Architect/Engineer nor the Field Representative shall be responsible for any safety obligations imposed on the Contractor by applicable industry standards, licensing requirements, laws or regulatory requirements.

END OF ARTICLE

4. OWNER

(June 12, 2012)

- A. Unless otherwise specified or excluded elsewhere in the Contract Documents, the records of borings, test excavations and other subsurface investigations, if any, are offered as information only and solely for the convenience of the Contractor. The Owner does not warrant or guarantee either that said records are complete or that the said records will disclose the actual subsurface conditions. The interpretation of the records and the conclusions drawn therefrom as to the actual existing subsurface conditions are the sole responsibility of the Contractor.
- B. Any estimates of quantities of work or materials, based on said borings, test excavations and other subsurface investigations are not warranted by the Owner to indicate the true quantities or distribution of quantities unless the Contractor is expressly directed to rely on such information to prepare and submit his Bid.
- C. If the Contractor is notified by the Owner to correct defective or nonconforming work, and the Contractor fails to promptly proceed with corrective action in a reasonable time, the Owner may, upon written notice, accomplish the redesign, repair, rework or replacement of nonconforming work by the most expeditious means available and backcharge the Contractor for the cost incurred. The cost of backcharge work shall include all reasonable costs associated with the corrective action.
- D. The Owner shall separately invoice or deduct from payments, otherwise due to the Contractor, the costs as provided herein. The Owner's right to backcharge is in addition to any or all other rights and remedies provided in this Contract, or by law. The performance of backcharge work, on behalf of the Owner, shall not relieve the Contractor of any of its responsibilities under this Contract including but not limited to express or implied warranties, specified standards for quality, contractual liabilities and indemnifications, and the Contract Time.
- E. The Field Representative and/or Architect/Engineer will administer the Contract and the orders of the Owner are to be given through the Field Representative and/or Architect/Engineer. The Field Representative and/or Architect/Engineer shall determine the amount and quality of the several kinds of work performed and materials furnished which are to be paid for under the Contract.
- F. The Field Representative will observe the Contractor's work for compliance with the Contract Documents. Such observation shall extend to all or any part of the work done and to the preparation, fabrication, or manufacture of the material to be used.
- G. Upon discovery, the Field Representative shall call the Contractor's attention to faulty workmanship or defective materials and shall reject work and materials not conforming to the requirements of the Contract Documents.
- H. When any work in progress or completed does not meet the requirements of the Contract Documents, the Field Representative shall have the authority to order the Contractor to shut down that portion of the work affected until the affected work is corrected to the satisfaction of the Field Representative. The Field Representative shall confirm this order in writing as soon as practicable, detailing the reasons for the

shutdown. Work performed in violation of the Field Representative's order to shutdown will not be accepted or paid for.

- I. The Field Representative is not authorized to revoke, alter, or waive any requirements of the Contract. The Field Representative will negotiate and act on behalf of the Owner to the authorized limits of his authority as specified in the Contract Documents.
- J. Whenever the Contractor intends to build, assemble or perform any portions of the Work away from the site, the Contractor shall promptly notify the Field Representative of such intentions, including where and when such work is to be performed, before such work starts. The Contractor shall also make arrangements for access thereto by the Field Representative and/or the Architect/Engineer so that the aforementioned portions of the Work may be inspected as needed.
- K. The fact that the Field Representative has not made early discovery of materials furnished or work performed which does not meet the requirements of the Contract Documents, shall not bar the Field Representative from subsequently rejecting said materials or work and does not relieve the Contractor of his responsibility to meet the requirements of the Contract Documents.
- L. The Field Representative shall not act as a foreman or perform other duties for the Contractor, nor interfere with the management of the work by the Contractor.
- M. The administration, observation of the work, and actions by the Field Representative, as herein provided, shall not be construed as undertaking supervisory control of the construction work or of means and methods employed by the Contractor or his Subcontractors and shall not relieve the Contractor from any of his responsibilities or obligations under the Contract; the Contractor shall not request or attempt to require the Field Representative to undertake such supervisory control or to administer, to supervise, to inspect, to assist, or to act in any manner so as to relieve the Contractor from such responsibilities or obligations.
- N. The Field Representative shall decide all questions relating to the rights of different prime Contractors on the Project or site.
- O. All materials and each part or detail of the work shall be subject to observation by the Field Representative and/or the Architect/Engineer. The Architect/Engineer and the Field Representative shall be allowed access to all parts of the work and shall be furnished with such information and assistance by the Contractor as is required.
- P. Miami-Dade County enters into this Contract solely in its proprietary capacity. Nothing in this Contract is intended to bind or otherwise restrict the discretion of Miami-Dade County acting in its regulatory capacity, including but not limited to the regulatory acts of the Departments of Regulatory and Economic Resources (RER), Transportation and Public Works (DTPW), Fire-Rescue (MDFRD) and Water & Sewer (WASD) or their successors.

END OF ARTICLE

5. CONTRACTOR

(June 12, 2012)

- A. If the Contractor hereunder is comprised of more than one legal entity, each such entity shall be jointly and severally liable hereunder.
- B. The Contractor shall hold valid current certificate(s) of competency for the type of work to be performed, in accordance with the qualifications requirements as set forth in Chapter 489 of the Florida Statutes and Chapter 10 of the Code of Miami- Dade County.
- C. The Contractor shall maintain within Miami-Dade County, Florida, a duly authorized agent to accept service of legal process on its behalf, and shall keep the Owner advised of such agent's name and address, during the duration of the Contract, and for three years after final payment or as long as Contractor has warranty obligations under these Contract Documents, whichever period terminates later. The Contractor shall complete the form titled "Contractor Agent to Accept Service" included in the Contract Documents and submit it to the Architect/Engineer prior to NTP.
- D. The Contractor shall be responsible for the complete performance for all of the work under the Contract, and for the methods, means, and equipment used in performing the Contract and for all materials, tools, apparatus and property of every description used in connection therewith.
- E. Upon approval of the Contractor's schedule by the Owner, the Contractor will submit written confirmation from all his Subcontractors agreeing to work within the timeframes specified in the Contractor's approved schedule.
- F. Contractor's Superintendent: The Contractor shall provide a superintendent at the site at all times who is competent in the type of work being performed to act as the Contractor's agent, and shall give that superintendent the full authority to receive instruction from the Field Representative or Architect/Engineer and to execute the order or directions of the Field Representative or Architect/Engineer, including the prompt supply of all materials, tools, equipment, labor, and incidentals that may be required. The Contractor shall furnish such superintendence regardless of the amount of work that is subcontracted, and the superintendent shall read, speak, write and understand English. The Contractor shall also maintain at least one other employee on the work site during Project working hours who speaks and understands English. This superintendent shall be responsible for keeping written daily logs of the work on the project.
- G. The competency of the superintendent shall be demonstrated through licensure or certification in contracting, engineering, trade or experience as applicable to the work being performed. Proof of licensure, certification or qualification of the superintendent must be provided to the Owner at the pre-construction conference and is subject to the approval of the Architect/Engineer or Field Representative after Contractor receipt of said requirements.

- H. In the event that the Field Representative or Architect/Engineer determines, through the course of the actual work progress, that the superintendent lacks the knowledge or expertise necessary to execute the work in an efficient and competent manner, in keeping with all current codes and best practices, the Field Representative or Architect/Engineer shall notify the Contractor in writing and the superintendent shall be replaced by the Contractor with a person acceptable to the Field Representative or Architect/Engineer within five (5) working days.
- I. The Contractor's failure to replace the superintendent in the time allotted shall be cause for the Owner to suspend work with such delays chargeable to the Contractor as Liquidated Damages as specified elsewhere in this contract.
- J. The Contractor shall maintain a daily accounting of his daily manpower, by trade and position, and provide this information to the Field Representative on a weekly basis.

END OF ARTICLE

6. SUBCONTRACTORS

(June 12, 2012)

- A. The Contractor will be permitted to subcontract portions of the Work to competent Subcontractors. Such Subcontractors shall hold valid current certificate(s) of competency for the type of work to be performed, in accordance with the qualifications requirements as set forth in the Florida Statutes and the Code of Miami- Dade County.
- B. Nothing contained herein shall create any contractual relationship between the Owner and any level of Subcontractor, materialman or supplier.
- C. All work performed for the Contractor by a Subcontractor shall be pursuant to an appropriate agreement between the Contractor and the Subcontractor which shall contain provisions that:
 - 1) Preserve and protect the rights of the Owner and any of its authorized representatives under the Contract, including but not limited to, the Architect/Engineer and Field Representative, with respect to the Work to be performed under the subcontract so that the subcontracting thereof will not prejudice such rights;
 - 2) Require that such Work be performed in accordance with the requirements of the Contract Documents including the Contractor's approved schedule;
 - 3) Require submission to the Contractor of applications for payment under each subcontract to which the Contractor is a part, in reasonable time to enable the Contractor to apply for payment in accordance with any and all payment provisions of the Contract Documents;
 - 4) Require that all claims for additional costs, extensions of time, damages for delays or otherwise with respect to subcontracted portions of the Work shall be submitted to the Contractor (via any Subcontractor or Sub-subcontractor or Supplier where appropriate) in sufficient time so that the Contractor may comply in the manner provided in the Contract Documents for like claims by the Contractor upon the Owner;
 - 5) Require specific consent to all relevant provisions of the Contract Documents; and
 - 6) Incorporate all flow-down clauses specifically called for in the Contract, as directed.
- D. Contractor Participation: The Contractor shall perform not less than 25 percent of the Work, not inclusive of materials purchased, with his own organization. If the Contractor is a joint venture, the requirement shall be satisfied by any one, or a combination of any of the joint venture partners. Where a percentage of a Bid Item is subcontracted, the dollar value of that percentage subcontracted will be based on the estimated cost of such Bid Item, determined from information submitted by the Contractor, subject to approval by the Owner. The materials produced by other than the Contractor's forces shall be considered as being subcontracted. If, during the

progress of the Work, the Contractor requests a reduction in such participation percentage, and the Owner determines that, due to the special nature of the conditions of the Work at the time, it would be to the Owner's advantage, the percentage of the Work required to be performed by the Contractor may be reduced, provided written approval of such reduction is obtained by the Contractor from the Owner. The Contractor shall not proceed with any such reductions until his request is approved in writing by the Owner or his authorized designee. Under no circumstances shall less than ten percent (10%) of the Work be performed with the Contractor's own forces.

E. Work Performed by Equipment-Rental Agreement:

- 1) The amount of work performed under equipment rental agreements shall not be considered Subcontractor work. However, for work to be performed by equipment-rental agreement, the Contractor shall notify the Architect/Engineer in writing of such intention before using the rented equipment, and shall indicate whether the equipment is being rented on an operated or non-operated basis. The Contractor's written notice shall contain a listing and description of the equipment and a description of the particular work to be performed with such equipment. As an exception to the above requirements for a written notice to the Architect/Engineer, such notice will not be required for equipment to be rented (without operators) from an equipment dealer or from a firm whose principal business is the renting or leasing of equipment.
- 2) The operators of rented equipment, whether rented on an operated or a non-operated basis, will be subject to wage rate requirements applicable to the Project. If equipment is being rented without operators, the Contractor shall be required to carry the operators on his own payroll. When equipment is rented on an operated basis, the Contractor, when required by the Contract or requested by the Architect/Engineer, shall submit payrolls from the lessor with the names of the operators shown thereon.

F. No work is to be performed at the Work site until the Contractor is in compliance with the Insurance Specifications, has furnished satisfactory evidence of required insurance to the Owner and obtained all required permits.

G. Approval of Subcontractor:

- 1) Prior to entering into any subcontract for Work to be performed on the Project, the Contractor shall secure the approval of the Owner regarding the prospective subcontractor's qualifications, employment data and compliance with CSBE program requirements. The forms used to provide the required information shall be the same as those included in the Forms for Bidding. The Owner will review the submittal from each Subcontractor, and will furnish written notification to the Contractor concerning approval of the award of the subcontract. If the Owner objects to the proposed award or fails to respond to the Contractor within five (5) business days of the complete submittal of the required information, the Contractor may furnish written notice of another subcontractor for consideration. The Owner may, at its discretion, waive or reduce subcontractor information submittal requirements as it deems appropriate.

- 2) In accordance with Ordinance 97-104, codified in Miami-Dade County Code Sections 2-8.1 and 10-33.01, the Contractor shall not, without written consent of the Owner, either replace any subcontractor or permit any such subcontract to be assigned or transferred, or allow that portion of the Work to be performed by anyone other than the approved subcontractor, except he may perform the work himself with qualified personnel upon written notice to the Owner in accordance with applicable law.

END OF ARTICLE

7. PROSECUTION OF THE WORK

(June 12, 2012)

A. Workmanship and Unauthorized Work

- 1) Work under this Contract shall be performed in a skillful and workmanlike manner. Unless otherwise indicated in the Contract Documents, the Contractor shall be solely responsible for means and methods and for the coordination of all trades through completion of the Work and without damage to the existing or newly installed components and surfaces. The Architect/Engineer or Field Representative may, in writing, require the Contractor to remove from the work any employee the Architect/Engineer or Field Representative determines incompetent, careless or otherwise objectionable. Such request shall be at no cost to the Owner.
- 2) Unauthorized Work: Work performed beyond the lines and grades shown on the Contract Drawings and approved Shop Drawings or established by the Owner, and Extra Work done without a Work Order or Change Order, will be unauthorized work and the Contractor will receive no compensation therefor. If required by the Owner, unauthorized work shall be remedied, removed or replaced by the Contractor at the Contractor's expense. Upon failure of the Contractor to remedy, remove or replace unauthorized work, the Owner may at its discretion, remedy, remove or replace the unauthorized work and the Contractor shall bear the responsibility for any and all costs and for delays resulting from such work.
- 3) The entire work and each part thereof, unless otherwise specified in the Contract Documents, shall be placed at the location, elevation, grade and gradient specified, and in proper alignment and adjustment. The Contractor shall provide all frames, forms, falsework, shoring, guides, anchors and temporary structures required to ensure these results.
- 4) No deviation from the approved Contract Documents shall be permitted without the prior written approval of the Architect/Engineer and/or Owner, by Work Order or Change Order, which approved deviation(s) shall be documented to the extent required by the Contract Documents.
- 5) The Contractor shall, at all times, employ sufficient labor and equipment for prosecuting the work to full completion in the manner and time required by the Contract Documents. All workers shall have sufficient skill and experience to properly perform the work assigned to them. Workers engaged in special work or skilled work shall have sufficient experience in such work and in the operation of the equipment required to perform the work satisfactorily.
- 6) All proposed equipment shall be of sufficient size and in such mechanical condition as to meet requirements of the work, producing a satisfactory quality of work. Equipment used on any portion of the work shall be such that no damage to previously completed work, adjacent property, or existing facilities will result from its use.

- 7) When the Contract Documents specify the use of certain methods and equipment, such methods and equipment shall be used unless others are authorized in writing by the Architect/Engineer by Work Order or Change Order. If the Contractor desires to use a method or type of equipment other than specified in the Contract, he may request permission from the Architect/Engineer to do so. The request shall be in writing and shall include a full description of the methods and equipment proposed and of the reasons for desiring to make the change. If approval is given, it will be on the condition that the Contractor will be fully responsible for producing work in conformity with Contract requirements. If, after trial use of the substituted methods or equipment, the Architect/Engineer determines that the work produced does not meet Contract requirements, the Contractor shall discontinue the use of the substitute method or equipment and shall complete the remaining work with the specified methods and equipment. The Contractor shall remove any deficient work and replace it with work of specified quality, or take such other corrective action as the Architect/Engineer may direct, at no additional cost to the Owner. No change will be made to the Contract price or the Contract Time as a result of authorizing a change in methods or equipment under this article.
- 8) The Contractor shall give constant attention to the work to facilitate the progress thereof, and he shall cooperate with the Architect/Engineer and its Field Representatives and with other Contractors in every way possible.
- 9) The Contractor warrants to the Owner that all materials and equipment furnished under this Contract will be new unless otherwise specified, and that the work will be of good quality, free from faults and defects in materials and workmanship for a period of one year from the date of Substantial Completion, unless otherwise required under this Contract. Work not conforming to these standards may be considered defective. If required by the Architect/Engineer, the Contractor shall furnish satisfactory evidence as to the kind and quality of materials and equipment.

B. Material

- 1) Unless otherwise indicated in the Contract Documents, equipment, material and products incorporated in the Work covered by this Contract shall be new and of the grade specified for the purpose intended. Unless otherwise specifically indicated, reference to equipment, material, product, or patented process by trade name, make, or catalog number, shall be regarded as establishing a standard of quality and shall not be construed as limiting competition. The Contractor may, at his option and, subject to the approval of the Architect/Engineer, use any equipment, material, article, or process which is equivalent to that named, subject to the requirements of these Contract Documents or propose a substitute equipment, material, article or process as indicated below. The Contractor shall at all times comply with established Green Building or LEED standards, if applicable, and as established in the Contract Documents. Proposed alternative equipment, material, products, or patented processes shall be considered equivalent if the Architect/Engineer

determines that the proposed alternative is functionally equal to and/or sufficiently similar to that specified in the Contract Documents.

- 2) The Architect/Engineer shall be the sole judge of the quality, suitability and cost of the proposed alternative equipment, material, article or process. A proposed alternative shall be considered equivalent and/or functionally equal to that specified in the Contract Documents if, in the exercise of reasonable judgment, the Architect/Engineer determines that the proposed alternative is at least equal in materials of construction, quality, durability, appearance, strength and design characteristics, will reliably perform at least equally well the function and achieve the results imposed by the design concept and has a proven record of performance and availability.
- 3) If the Architect/Engineer determines that a proposed alternative does not qualify as equivalent or functionally equal, the alternative may be proposed for consideration as a substitute subject to the Contractor submitting sufficient information as provided below to allow the Architect/Engineer to determine that the proposed alternative is essentially equivalent to or better than the specified item and is an acceptable substitute for that said specified item.
- 4) The burden of proving the quality, suitability and cost of an alternative shall be borne by the Contractor. All information required by the Architect/Engineer in judging an alternative shall be supplied by the Contractor at the Contractor's expense. The Architect/Engineer's costs in evaluating a proposed alternative, irrespective of its acceptance, will be reimbursed by the Contractor to the Owner. In the case of approved alternatives, the Contractor shall also reimburse the Owner for the Architect/Engineer's costs to revise the Contract Documents.
- 5) The Contractor certifies that, if approved and incorporated into the Work, there will be no increase in cost to the Owner or in Contract Time and the proposed alternative shall conform substantially to the detailed requirements of the item specified in the Contract Documents.
 - a. Where use of an alternative material involves redesign of or changes to other parts of the Work, the cost and the time required to affect such redesign or change will be considered in evaluating the suitability of the alternative material. All costs pertaining to redesign and changes in other parts of the Work, including remedial work to completed work, shall be at the Contractor's expense.
 - b. No action relating to the approval of alternative materials will be taken until the request for approval of the alternative materials is made in writing by the Contractor accompanied by complete data as to the quality, suitability and cost of the materials proposed. Such request shall be made at least 60 days before the early start date of the activity. Any delays in receiving approval shall be the responsibility of the Contractor.
 - c. The Architect/Engineer will examine and review the proposed alternative with the Owner and return it, within twenty-one (21) calendar days from the date of its receipt at the Architect/Engineer's

office, to the Contractor noted with the final decision. If the final decision approves either an equal or a substitution, the approval must also contain the Owner's written approval. When requested by the Architect/Engineer, the Contractor shall resubmit such Shop Drawings, descriptive data and samples as may be required.

- d. Where classification, rating, or other certification by a body such as, but not limited to, Underwriters' Laboratories Inc. (UL), National Electrical Manufacturer's Association (NEMA), or American Railway Engineering Association (AREA) is a part of the specification for any material, proposals for use of alternative materials shall be accompanied by reports from the listed body, or equivalent independent testing laboratory, indicating compliance with Contract Documents requirements. Testing required proving equality of the material proposed shall be at the Contractors expense.
 - e. Approval of an alternative material will be only for the characteristics and use named in such approval, and shall not change or modify any Contract requirement, or establish approval for the material to be used on any other Project for the Owner.
- 6) Source of Supply and Quality of Materials: The Contractor shall furnish all materials and products required to complete the Work except those designated to be furnished by the Owner.
- a. Notwithstanding prior inspection and approval by the Architect/Engineer, only materials conforming to the requirements of the Contract Documents shall be incorporated in the Work.
 - b. The materials shall be manufactured, handled and incorporated so as to ensure completed work in accordance with the Contract Documents.
- 7) Defective Materials: Contractor-furnished materials not conforming to the requirements of the Contract Documents will be rejected, whether in place or not. Rejected material shall be removed immediately from the Work site. No rejected material, the defects of which have been subsequently corrected, shall be used in the Work. The Owner may cause the removal and replacement of rejected material and the cost thereof will be deducted from any monies due or to become due to the Contractor.
- 8) Handling of Materials: Materials shall be transported, handled and stored by the Contractor in a manner which will ensure the preservation of their quality, appearance and fitness for the Work. Materials shall be stored in a manner to facilitate inspection.
- 9) The Owner will have no responsibility to the Contractor concerning local material sources.
- a. The Contractor shall make all necessary arrangements with the owners of material sources. The Contractor shall pay all costs in connection with making such arrangements, exploring, developing

and using material sources, whether or not indicated, except such costs as the Owner expressly agrees in writing to assume.

10) Disposal of Material Outside the Work Site: Unless otherwise specified in the Contract Documents, the Contractor shall make his own arrangements for properly disposing of waste and excess materials outside the Work Site and he shall pay all costs therefore. Contractor shall comply with all local, state and federal requirements when disposing of waste and excess materials.

a. Prior to disposing of material outside the Work Site, the Contractor shall obtain written permission from the owner on whose property the disposal is to be made. The Contractor shall file with the Architect/Engineer said permit, or a certified copy thereof, together with a written release from the property owner absolving the Owner from any and all responsibility in connection with the disposal of material on said property.

11) Property Rights in Materials: The Contractor shall have no property right in materials after they have been attached or affixed to the Work or the soil, or after payment has been made by the Owner to the Contractor for materials delivered to the site of the Work, or stored subject to or under the control of the Owner, as provided in these Contract Documents. However, the Contractor shall be responsible for the security of the material on-site until Final Acceptance by the Owner.

C. Methods of Sampling and Testing

1) Sampling and testing of all materials shall be as set forth in the Contract Documents. Except for quality control testing and any other testing that may be the direct responsibility of the Contractor as set forth in the Contract Documents, the testing of samples and materials will be made at the expense of the Owner by the project testing laboratory. The Contractor shall furnish the required samples without charge. Any and all fees for non-conforming materials or work shall be solely borne by the Contractor. The Contractor shall give sufficient notification to the Field Representative of the placing of orders for or receipt of materials to permit testing.

2) The Field Representative may inspect, at its source, any specified material or assembly to be used in the Work. Manufacturing plants may be inspected from time to time for the purpose of determining compliance with specified manufacturing methods or materials to be used in the Work and to obtain samples required for its acceptance of the material or assembly

Should the Field Representative conduct plant inspections, the following shall exist:

a. The Field Representative shall have the cooperation and assistance of the Contractor and the producer with whom he has contracted for materials.

- b. The Field Representative shall have full entry at all reasonable times to such parts of the plant that concern the manufacture or production of materials being furnished.
 - c. If required by the Field Representative, the Contractor shall arrange for adequate office or working space that may be reasonably needed for conducting plant inspections. Office or working space should be conveniently located with respect to the plant.
- 3) It is understood and agreed that the Owner shall have the right to retest any material which has been tested and approved at the source of supply after it has been delivered to the site. The Field Representative shall have the right to reject only material which, when retested, does not meet the requirements of the Contract Documents. In such an event, the cost of re-testing shall be borne by the Contractor if it results in a rejected material.
- 4) All inspections and testing of materials, assemblies and equipment will be performed in Miami-Dade County. If the Contractor's material or manufacturing sources are such that inspections or tests cannot be made in Miami-Dade County, all traveling and lodging expenses in connections with such inspections and testing shall be borne by the Contractor.

D. Meetings

- 1) A pre-construction conference will be held prior to the issuance of the Notice to Proceed to discuss the work to be performed under this contract. The Contractor and its major Subcontractors shall be required to attend this meeting. The Contractor will be advised of the time, date and location of the meeting.
- 2) The Contractor shall attend weekly construction coordination meetings at a time and place to be designated by the Architect/Engineer. These meetings are intended to determine job progress, identify job problems, assist in solving and preventing job problems, and promote coordination with all entities involved in the Contract and with other Owner Contractors. The Contractor shall cause Subcontractors and suppliers to attend as he deems advisable, or as requested by the Architect/Engineer. Unless otherwise provided for in these Contract Documents, the Contractor shall be responsible for generating and distributing meeting minutes for all such meetings.

E. Permits and Compliance with Laws

- 1) Unless otherwise provided for in these Contract Documents, the Contractor shall be responsible for obtaining necessary licenses and permits and for complying with applicable Federal, State, County and Municipal laws and latest codes and regulations in connection with the prosecution of the Work. (For payment of permit(s), see Special Provisions). No time extensions will be allowed for delays in obtaining the required permits unless revisions directly caused by the Owner or its agents are required to the Contract Drawings due to changes in codes, regulations and applicable contract standards during the contract term. See Special Provisions for additional permit requirements.

- 2) The Owner will not pay or reimburse the Contractor for any penalties relating to his permits or fees as a result of the Contractor's failure to timely obtain all his permits, inspections, approvals, etc.
- 3) The Contractor shall observe and comply with all applicable Federal, State, County and other laws, codes, ordinances, rules and regulations of the Federal, State and County governments, all authorities having jurisdiction, and any and all programs developed in compliance therewith, in any manner affecting the conduct of the Work.
- 4) Dewatering of excavations shall be performed in accordance with the applicable provisions of the Department of Environmental Resources Management (DERM), Florida Department of Environmental Protection (DEP), U.S. Environmental Protection Agency (USEPA) and the South Florida Water Management District (SFWMD) Dewatering Permits and/or any and all authorities having jurisdiction and any other requirements specified in the Contract Documents. The means and methods of dewatering shall be determined by the Contractor who shall bear the full cost of same as part of the contract price.
- 5) All construction activities shall be subject to the pollution prevention requirements established under the National Pollutant Discharge Elimination System (NPDES) program under the Clean Water Act regulating storm water discharge from construction sites.
- 6) Upon completion of all of the work contemplated under the Contract Documents, the Contractor shall obtain and deliver to the Field Representative such Certificate(s) of Occupancy or Certificate(s) of Completion as required by the Florida Building Code and/or authority having jurisdiction.
- 7) The Contractor shall be subject to and comply with all the provisions of Miami-Dade County Code Section 2-8.4.1, which provides that, whenever any individual or corporation or other entity attempts to meet its contractual obligations with the County through fraud, misrepresentation or material misstatement, the County shall, whenever practicable, terminate the Contract. The Contractor is further directed to Section 10-38 of the Miami-Dade County Code which provides for the debarment of County contractors.

F. Coordination and Access

- 1) Other Contracts: The Owner may undertake or award other contracts for additional work, and the Contractor shall fully cooperate and coordinate with other Contractors and the Owner and carefully fit his own work to such additional work. The Contractor shall not perform any act which will interfere with the performance of work by any other contractor or by the Owner. The Contractor shall be responsible for obtaining all necessary scheduling details from other Contractors and these requests must be provided, in writing, to the Owner. The Architect/Engineer shall have the authority to resolve conflicts related to coordination between Contractors.
- 2) In the event of interference between the work of the Contractor and other contractors working concurrently at the Site, the Field Representative will

instruct the Contractor as to which work has priority in performance and such instructions shall be binding upon the Contractor.

- 3) Utility companies, railroads, and municipal agencies having facilities within the limits of the Work shall have access to their facilities at all times for inspection and repair.

G. Rights in Land and Improvements

The Contractor shall make no arrangements with any person to permit occupancy or use of any land, structure or building within the Work Site for any purpose whatsoever, either with or without compensation, in conflict with any agreement between the Owner and any property owner, former property owner or tenant of such land, structure or building. The Contractor shall not occupy Owner-owned property outside the Work Site without obtaining prior written approval from the Owner.

H. Interference With Existing Utilities

- 1) Attention of the Contractor is specifically directed to the need for careful control of all aspects of his work to prevent damage to cables, ducts, water mains, sewers, fire mains, telephone cables, fuel lines, radar cables, and any other existing overhead or underground utilities and structures.
- 2) Before commencing work in any given area, the Contractor shall contact utility companies to identify any potential conflicts. Further, the Contractor shall also carefully review the Plans, survey and search the site for utility locations, and determine possible utility conflicts. All known above and underground utilities, including, but not limited to, electrical, telephone, communications, lighting cables, fuel lines, sewer, drainage and water pipes, and other existing structures are shown on the Plans for reference purposes only, but no guarantee is expressed or implied that the information is accurate. It shall be the sole responsibility of the Contractor to ascertain and/or verify the location of any and all such utilities or structures using magnetic and electronic detectors and by hand excavation or other appropriate measures before performing any work that could result in damage to such existing utilities or structures. The Contractor shall make a thorough search of the particular location for underground utilities or structures whether or not shown on the drawings, before excavation work is commenced in any particular location. To this end the Contractor shall provide and maintain throughout the term of the Contract, electronic and magnetic detecting devices capable of locating underground utilities or structures. The Contractor shall, after locating primary and critical existing utilities, mark their location with indelible material or other means satisfactory to the Field Representative and maintain above ground physical identification during the work.
- 3) In the event of damage to, or accidental disruption of utilities or other facilities as a result of the Contractor's operations, the Contractor shall take immediate steps to repair or replace all damage and to restore all services. Further, the Contractor shall engage any additional outside services which may be necessary to prosecute repairs on a continuous "around the clock" basis until

services are restored. The Contractor shall also provide and operate any supplemental temporary services to maintain uninterrupted use of the facilities. All costs involved in making repairs and restoring disrupted service resulting from the Contractor's work shall be borne by the Contractor and the Contractor shall be fully responsible for any and all claims resulting from the damage.

I. Protection of Existing Facilities, Vegetation, Structures, Utilities and Improvements

- 1) The Contractor shall preserve and protect existing vegetation such as trees, shrubs, and grass on or adjacent to the work site which are not indicated to be removed and which do not unreasonably interfere with the construction Work and he shall replace in kind the vegetation, shrubs and grass damaged by him at his own expense.
- 2) The Contractor shall protect from damage all utilities, foundations, walls or other parts of adjacent, abutting or overhead buildings, railroads, bridges, structures, surface and subsurface structures at or near the site of the Work and shall repair or restore any damage to such facilities, except utilities, resulting from failure to comply with the requirements of this Contract or the failure to exercise reasonable care in the performance of the Work. If, after receipt of notification from the Architect/Engineer, the Contractor fails to or refuses to repair any such damage promptly, the Owner may have the necessary Work performed and charge the cost thereof to the Contractor.
- 3) At points where the Contractor's operations are adjacent to utility facilities, damage to which might result in expense, loss, disruption of service or other undue inconvenience to the public or to the owners, Work shall not be commenced until all arrangements necessary for the protection thereof have been made by the Contractor. The Contractor shall be solely and directly responsible to the owners and operators of such utilities for any damage, injury, expense, loss, inconvenience, or delay, caused by the Contractor's operations.
 - a. Where public utilities or their appurtenances interfere with permanent construction, unless otherwise specified, work involved in permanently relocating or otherwise altering such public utilities and their appurtenances will not be a part of this Contract but will be done by utility owners at no cost to the Contractor. If the Contractor wishes to have utilities temporarily relocated, he shall make necessary arrangements with utility owners and reimburse them at his own expense for cost of the Work. The Contractor shall keep the Architect/Engineer advised of temporary relocation arrangements.
 - b. The Contractor shall not repair or attempt to repair utility damage but shall immediately contact the utility owner. The Contractor shall obtain the name, address and telephone number of each utility company that the work will affect and the person in such utility company to contact. He shall submit to the Architect/Engineer said names, addresses and telephone numbers.

- 4) The Contractor shall comply with the latest version of the Florida Building Code or the Code under which the Contract Documents were approved, whichever is applicable at the time the Work is performed.
- 5) In order to safeguard the owners and tenants of abutting property and at the same time prevent unjust or fraudulent claims against the Contractor the Government, State, the Owner and the Architect/Engineer in respect thereto, the Contractor shall cause a detailed examination of abutting property to be made before construction is begun. The owner or tenant of each parcel or structure or his or their duly authorized representative will be invited to be present during the examination by a notice in writing delivered by the Contractor to a person in charge of the premises or structure, or by the mailing of the notice to the owner at the premises. The Architect/Engineer will attend while the Contractor makes the detailed examination. A complete record including photographs of the existing conditions of each parcel or structure shall be made in triplicate, signed by the Contractor, Owner and the Architect/Engineer and one copy will be delivered to the Owner, one to the Architect/Engineer and one will be retained by the Contractor. At such time as the Architect/Engineer may direct, or upon the filing of the verified statement by the owner, tenant, lessee, operator or occupant of the building structure, and in any event, upon the completion of any work that in the opinion on the Architect/Engineer might affect the abutting property, the Contractor will make another detailed examination of such abutting property. A complete record of the then existing conditions of said property will be made in triplicate, signed by the Contractor and one copy will be delivered to the Owner, one to the Architect/Engineer and one will be retained by the Contractor. In any action, which may be brought by any owner, tenant, lessee, operator or occupant of abutting property to recover under the provisions of this article or any paragraph hereof, the record of the existing conditions of each parcel will be prima facie evidence of the conditions thereof at the time of the making of the examination.
- 6) The Contractor shall maintain access to fire hydrants and fire alarm boxes throughout the prosecution of the Work. Hydrants, alarm boxes and standpipe connections shall be kept clear and visible at all times unless approved otherwise. If visibility cannot be maintained, the Contractor shall provide clearly visible signs showing the location of the fire hydrant, fire alarm box or standpipe connection. The Contractor shall promptly notify the authority having jurisdiction of any impairment to any fire systems.

J. Damage to the Work and Responsibility for Materials

- 1) The Contractor shall be responsible for materials delivered and work performed until completion and Final Acceptance of the entire construction thereof, except those materials and work which may have been accepted under the applicable sections of this article and shall take all necessary steps to protect the Work, from all causes, at his expense.
- 2) The Contractor shall bear the risk of injury, loss or damage to any and all parts of the Work for whatever cause, whether arising from the execution or from the

non-execution of the Work, except as provided for in this article. The Contractor shall rebuild, repair or restore work and materials which have been damaged or destroyed from any cause before Completion and Acceptance of the Work and shall bear the expense thereof. The Contractor shall provide security including, but not limited to, security guards, temporary drainage systems and erection of temporary structures and temporary fencing as necessary to protect the Work and materials from damage.

- 3) The Contractor shall be responsible for materials not delivered to the site for which any progress payment has been made to the same extent as if the materials were so delivered.
- 4) The Contractor's responsibility for material shall be the same for Owner-furnished material, upon receipt of said material from the Owner, under this Contract as for Contractor-furnished material.
- 5) Relief from Maintenance and Responsibility: The Contractor may request, in writing, from the Owner, that the Owner relieve the Contractor of the duty of maintaining and protecting certain portions of the Work, as described in this paragraph, which have been completed in all respects in accordance with the requirements of the Contract. Such action by the Owner will relieve the Contractor of responsibility for injury or damage to said completed portions of the Work resulting from use by the Owner or the public for any cause, but not from injury or damage resulting from the Contractor's own operations or negligence. Portions of the Work for which the Contractor may be relieved of the duty of maintenance and protection, as provided in this paragraph, include the following:
 - a. Early possession by the Owner of any portion of the Work, in accordance with the Contract Documents.
 - b. This Paragraph 5 does not relieve the Contractor of responsibility for repairing or replacing defective work or materials in accordance with the Contract requirements.

K. Emergencies

- 1) In an emergency affecting the safety of life, the Work, or adjacent property, the Contractor shall notify the Field Representative and the Architect/Engineer as early as possible that an emergency exists. In the meantime, without special instruction from the Architect/Engineer as to the manner of dealing with the emergency, the Contractor shall act at his own discretion to prevent such threatened loss or injury. As emergency work proceeds, the Field Representative and the Architect/Engineer may issue instructions, which the Contractor shall follow. The compensation to which the Contractor is entitled on account of emergency work, if any, shall be limited to emergencies not caused by actions or inactions of the Contractor determined in accordance with the Contract Documents, where applicable.
- 2) For purposes of this article, an emergency is defined as an act or event that has already occurred, not caused by actions or inactions of the Contractor, which, if no immediate action is taken may affect the safety of life, the work, or adjacent property. This article does not apply to steps taken by the Contractor to protect

the Work, adjacent structures, utilities, existing vegetation, etc. under other sections of the Contract Documents. Furthermore, this article does not apply to preparations the Contractor may make prior to storms or hurricanes or other acts of God.

L. Accident Prevention

- 1) Contractor shall be solely responsible for initiating, maintaining and supervising all safety precautions and programs in connection with the Work. Contractor shall take all necessary precautions for the safety of, and shall provide the necessary protection to prevent damage, injury or loss to:
 - a. All persons on the Site or who may be affected by the Work;
 - b. All the Work and materials and equipment to be incorporated therein, whether in storage on or off the Site; and other property at the Site or adjacent thereto, including trees, shrubs lawns, walks, pavements, roadways, structures, utilities, and underground facilities not designated for removal, relocation, or replacement in the course of construction.
- 2) Contractor shall comply with all applicable laws and regulations relating to the safety of persons or property, or to the protection of persons or property from damage, injury, or loss and shall erect and maintain all necessary safeguards for such safety and protection.
- 3) Upon notification from the Owner or its representative(s), the Contractor shall promptly correct any deficiencies affecting the safety and well being of the construction workers and the public that have been identified by the notice.
- 4) Should a situation of imminent danger be identified, work in the affected area must be suspended immediately until the condition has been corrected. Imminent danger is defined as the exposure or vulnerability to harm or risk that is impending or about to occur as defined by the Field Representative or the Architect/Engineer. The Contractor will not be entitled to future claims alleging impacts caused by the Owner stoppage of the Work due to safety reasons.

M. Warranty of Work

- 1) Except where longer periods of warranty are indicated for certain items, the Contractor warrants the Work under the Contract to be free from faulty materials and workmanship for a period of not less than one (1) year from the date of Substantial Completion. This one-year period shall be covered by the Surety Performance Bond as specified in this Contract, except that in the case of defects or failure in a part of the work which the Owner takes possession of prior to Substantial Completion, such a period shall commence on the date the Owner takes possession. Upon receiving notification from the Owner or any public body, to whom the ownership of the Work has been transferred or who has agreed to maintain the Work, the Contractor shall immediately remedy, repair, or replace, without cost to the Owner or other notifying party and to the entire satisfaction of the notifying party, defects, damages, or imperfections

due to faulty materials or workmanship appearing in said Work within said period of not less than one year. Remedial work shall carry the same warranty as the original work starting with the date of acceptance of the replacement or repair. Payment to the Contractor will not relieve him of any obligation under the Contract.

- 2) The Contractor, at no additional expense to the Owner, shall also remedy damage to equipment, the site, or the buildings or the contents thereof, which is the result of any failure or defect in the Work, and restore any Work damaged in fulfilling the requirements of the Contract. Should the Contractor fail to remedy any such failure or defect within ten (10) days after receipt of notice thereof, the Owner will have the right to replace, repair, or otherwise remedy such failure or defect and deduct all costs from the Contractor's pay request or Performance Bond if final payment has been made.
- 3) The Contractor will correct all latent defects discovered within ten (10) years after Substantial Completion provided that the Owner shall notify the Contractor of each latent defect within the time specified by law. The Contractor, without prejudice to the terms of the Contract, shall be liable to the Owner for all damages sustained by the Owner resulting from latent defects, fraud, or such gross mistakes as may amount to fraud, discovered after the stated guarantee and warranty periods have expired. If the Contractor fails to act within ten (10) days, the Owner reserves the right to have the work performed by others at the expense of the Contractor, and the Contractor agrees to pay the Owner the reasonable cost associated with procurement, implementation and management thereof upon demand. The Owner shall also be entitled to reasonable attorney's fees, necessarily incurred upon the Contractor's refusal to pay the above costs.
- 4) Subcontractors', manufacturers' and suppliers' warranties and guaranties, expressed or implied, with respect to any part of the Work and any material used therein shall be deemed obtained and shall be enforced by the Contractor for the benefit of the Owner provided that, if directed by the Owner, the Contractor requires such subcontractors, manufacturers and suppliers to execute such warranties and guaranties, in writing, directly to the Owner.
- 5) The rights and remedies of the Owner provided in this article are in addition to and do not limit any rights and remedies afforded by the Contract or by law.
- 6) Nothing in the above intends or implies that this warranty shall apply to work that has been abused or neglected by the Owner, its agents or other public body, utility or railroad to which ownership has been transferred.

END OF ARTICLE

8. CONTRACT TIME

(June 12, 2012)

A. Notice to Proceed

- 1) The Owner may issue authorization to obtain permits to the Contractor after the Contractor has executed the Contract and has delivered the specified bonds and certificates of insurance in forms acceptable to the Owner, for the limited purpose of obtaining all necessary permits to complete the work. If the Contractor is unable to obtain all necessary permits within 30 days, through no fault of the Contractor, the Owner has the option, but not the obligation, to terminate the Contract, without fault to the Contractor or the Owner, effective immediately upon written notice by the Owner or give the Contractor additional time to obtain the permits. Upon the Contractor providing satisfactory evidence of obtaining the permits, the Owner will issue Notice to Proceed. Except as specifically authorized in writing by the Owner, the Contractor is not authorized to perform work (other than obtaining permits) under the Contract until the effective date of the Notice to Proceed, upon which the Contractor shall commence work and shall diligently prosecute the Work to completion within the time limits specified. The Contract time commences on the date shown on the Notice to Proceed.
- 2) Any Work Performed by the Contractor (other than obtaining permits) prior to Notice-To-Proceed shall be at the Contractor's own risk and shall not be considered as the basis for any claim.

B. Schedules

- 1) The Contractor shall provide, maintain, and periodically update schedules in strict accordance with the Contract Documents. The Special Provisions shall contain specific requirements for the form, content and date of submission of the baseline schedule and all schedule updates.
- 2) The Contractor shall prosecute the Work in accordance with the approved baseline Schedule or most recently approved revision to the baseline schedule. In the event that progress along the critical path is delayed, the Contractor shall revise his planning to include additional forces, equipment, shifts or hours as necessary to meet the time or times of completion specified in this Contract at no additional cost to the Owner. In addition, the Contractor shall revise his schedule to reflect these recovery actions and submit it to the Owner for review and approval it being understood that such approval will be as to the format and composition of the schedule and not the Contractor's means and methods. Additional costs resulting therefrom will be borne by the Contractor. Delayed progress is defined as:
 - a. A delay in the start or finish of any activity on the critical path (critical path is defined as the path with the least amount of float) of the approved baseline schedule or most recently approved revision to the baseline; or

- b. A delay in the start or finish of any non-critical activity which consumes more than the available float shown on the approved baseline schedule or most recently approved revision to the baseline, thereby making the activity critical and late; or
 - c. A projected completion date shown on a schedule update which is later than the contractual completion date; or
 - d. Any combination of the above.
- 3) Failure of the Contractor to comply with the requirements under this provision will be grounds for determination that the Contractor is not prosecuting the Work with such diligence as will ensure completion within the Contract Time. Upon such determination, the Owner may terminate the Contractor's right to proceed with the Work, or any separate part thereof, in accordance with the Contract Documents. If in the Contractor's estimation, the cause(s) of delay are beyond the Contractor's control, the Contractor shall adhere to the sections of the Contract Documents related to extensions of time, claims and others as appropriate.
- 4) The Contractor shall be responsible for scheduling and coordinating the work of all crafts and trades, subcontractors and suppliers, required to perform the Work and to complete the Work within the prescribed time. Any inefficiency or loss of productivity in the labor, materials, or special equipment of the Contractor or its subcontractors of any tier, from any cause, shall be the responsibility of the Contractor. No reimbursement of these or any other costs can be requested by or granted to the Contractor or any of its subcontractors of any tier for inefficiency or loss of productivity in labor, materials, or special equipment, except as specified in the paragraph in this article dealing with Liquidated Indirect Costs, for delays in the performance and completion of the Work directly caused by the Owner or its authorized representatives. Other than the exception described above, additional costs may only be paid to the Contractor as a result of additional Work added to the Contract scope of work.

C. Extensions of Time and Classification of Types of Delays

- 1) Once a delay has been identified and it has been established through a scheduling analysis that a delay affects the Project's end date or contractually mandated milestone date, the delay must be classified to determine responsibility and to compute damages, if any. Before the Contractor can submit a request for time extension, claim or any request for additional compensation involving or related to time, the Contractor must classify the delay(s) in accordance with the following classifications. These delay classifications shall be used by the Owner and the Contractor in resolving any time-related disputes. Delays fall into three basic categories: non-excusable, excusable, and compensable.
- a. Non-excusable delays are those delays to the critical path which were foreseeable at the time of contract award or delays caused by the Contractor due to the Contractor's fault or negligence or his/her own

inefficiencies or problems, due to his/her inability to coordinate subcontractors and/or other flaws in his/her planning. In these types of delays the Contractor is not entitled to extra time or compensation and the Owner may be allowed to assess Liquidated Damages or actual damages, depending on the contract provisions.

- b. Excusable delays are those delays to the critical path beyond the Contractor's control and without the active interference of the Owner, such as extreme weather (force majeure), strikes and delays caused by third parties (i.e. not the Contractor or the Owner). Contractors are granted a time extension but no additional compensation for the extended time of performance for excusable delays.
- c. Compensable delays are delays to the critical path caused by active interference or participation of the Owner or Owner's consultant. Examples of compensable delays are failure of the Owner to provide right-of-way, introducing late design changes, late review of shop drawings by the Owner or his Architect/Engineer and failure of the Owner to coordinate the work of various prime Contractors. In the case of a compensable delay, the compensation for the extended period of performance may cover, in addition to the direct cost due as a result of the changes, Liquidated Indirect Costs as specified in the Contract Documents.
- d. Concurrent delays involve two or more delays to the critical path occurring at the same time, either of which, had it occurred alone, would have affected the end date of the Project. In that event, the Contractor's sole remedy is a time extension and relief of Liquidated Damages with no compensation for extended cost for the concurrency delay period.
- e. The compensability of concurrent delays depends on the types of delays involved. The following shall determine the effects of concurrent delays on time extensions and compensable costs:
 - i. EXCUSABLE DELAY CONCURRENT WITH A NON-EXCUSABLE DELAY. For excusable delays concurrent with non-excusable delays, the Contractor is entitled to a time extension only. For example, it rains the day footings are to be excavated (excusable delay) but the excavation equipment was down for repairs (non-excusable delays).
 - ii. NON-EXCUSABLE DELAY CONCURRENT WITH A COMPENSABLE DELAY. For non-excusable delays concurrent with compensable delays, the Contractor is entitled to a time extension only. For example, if the Owner introduces a design change for a beam but the Contractor has failed to submit the shop drawings for said beam in a timely manner. This would be an example of a non-excusable delay (late shop drawings) concurrent with a compensable delay (Owner introducing design change).

iii. EXCUSABLE DELAY CONCURRENT WITH A COMPENSABLE DELAY. For excusable delays concurrent with compensable delays, the Contractor is entitled to a time extension only. For example, the Owner does not provide the necessary right-of-way to begin construction (compensable delay) but the Contractor's forces are on strike (excusable delay).

2) Time Extensions: The Contractor may be granted an extension of time and will not be assessed Liquidated Damages for any portion of the delay in completion of the Work, arising from acts of God, acts of the public enemy, fires, floods, epidemics, quarantine restrictions, freight embargoes, strikes, labor disputes, or weather more severe than the norm, provided that the aforesaid causes were not foreseeable and did not result from the fault or negligence of the Contractor, and provided further that the Contractor has taken reasonable precautions to prevent further delays owing to such causes, and has given to the Architect/Engineer immediate verbal notification, with written confirmation within 48 hours, of the cause or causes of delay. Within thirty (30) days after the end of the delay, the Contractor shall furnish the Architect/Engineer with detailed information concerning the circumstances of the delay, the number of days actually delayed, the appropriate Contract Document references, and the measures taken to prevent or minimize the delay. All requests for extension of time shall be submitted in accordance with the Contract Documents. Failure to submit such information will be sufficient cause for denying the delay claims. The Owner will ascertain the facts and the extent of the delay and its findings thereon will be final and conclusive subject to the dispute provisions in the Contract Documents. The extensions of time granted for these reasons shall be considered excusable and shall not be the basis for any additional compensation.

- a. Weather more severe than the norm shall apply only as it affects particular portions of the Work and operations of the Contractor, as determined by the Architect/Engineer. Weather more severe than the norm is defined as any situation exceeding the mean data as recorded by The National Climatic Data Center, Asheville, North Carolina and published by the National Oceanic and Atmospheric Administration (This data is taken from the table of normals, means, and extremes in the latest version of the "Local Climatological Data, Annual Summary with Comparative Data, Miami, Florida"). For the calculation of delays due to rain, precipitation of 0.01 inches or more a day shall be considered to be a rain day if the rain actually prevented the Contractor from performing work. The effects of weather less severe than the norm may be taken into account in granting time extensions at the Owner's sole discretion.
- b. An extension of time will not be granted for a delay to the critical path caused by a shortage of materials, except Owner-furnished materials, unless the Contractor furnishes to the Architect/Engineer documentary proof that he has diligently made every effort to obtain

such materials from every known source within reasonable reach of the Work. The Contractor shall also submit proof, in the form of a CPM network analysis data, that the inability to obtain such materials when originally planned, did in fact cause a delay in final completion of the Work which could not be compensated for by revising the sequence of his operations. Only the physical shortage of material will be considered under these provisions as a cause for extension of time. No consideration will be given to any claim that material could not be obtained at a reasonable, practical, or economical cost, unless it is shown to the satisfaction of the Architect/Engineer that such material could have been obtained only at exorbitant prices, entirely inconsistent with current rates taking into account the quantities involved and the usual practices in obtaining such quantities.

- 3) Delays Caused by Consultant and/or the Owner: If the Contractor's performance of the Work along the critical path is delayed by any condition or action directly caused by the Owner, and which was not foreseeable by the Contractor at the time the Contract was entered into, the Contractor shall, provide notification in accordance with the Contract Documents, of any such delay and of the anticipated results thereof. The Contractor shall cooperate with the Owner and use its best efforts to minimize the impact on the schedule of any such delay. In instances where a Contract change extends the Contract beyond the completion date, the Contractor may claim Liquidated Indirect Costs as specified in the paragraph in this article dealing with Liquidated Indirect Costs. These delays shall be considered compensable, except for the period in which these delays may be concurrent with Contractor-caused delays. If a delay on the part of the Owner is concurrent, that is, if it occurs at the same time as a Contractor-caused delay, the Owner-caused delay shall be considered an excusable delay for the portion of the Owner-caused delay which is concurrent with the Contractor-caused delay.
- 4) Delays Beyond Contractor's Control Not Caused by Consultant and/ or the Owner: If Contractor's performance of the Work along the critical path is delayed by any conditions beyond the control and without the fault or negligence of Contractor and not caused by the Owner, and which was not foreseeable by Contractor at the time this Contract was entered into, Contractor shall, provide immediate verbal notification with written notification in accordance with the Contract Documents, of any such delay and of the anticipated results thereof. Within two (2) calendars days of the termination of any such delay, Contractor shall file a written notice with the Architect/Engineer specifying the actual duration of the delay. If the Owner determines that the delay was beyond the control and without the fault or negligence of the Contractor and not foreseeable by the Contractor at the time this Contract was entered into, the Owner will determine the duration of the delay and may extend the time of performance of this Contract provided, however, that Contractor shall cooperate with the Owner and use its best efforts to minimize the impact on the schedule of any such delay. These delays shall

be considered excusable and the Contractor shall not be entitled to, and hereby expressly waives recovery of, any damages suffered by reason of the delays contemplated by this paragraph and extension of time shall constitute Contractor's sole remedy for such delays.

- 5) In addition to the delays in the Work specified in this section, delays in the Work directly caused by an act or omission by an owner of an adjoining property will not be considered an Owner-controlled delay. An owner of an adjoining property is a person, firm, corporation, partnership, or other organization who either owns or occupies, or both, structures or parcels or both, immediately adjacent to the Work Site. Extension of time for those delays will be considered excusable and shall be treated as specified in this article, provided that:
 - a. The Contractor has, in accordance with this article, given to the Architect/Engineer immediate verbal justification, with written confirmation within forty-eight (48) hours of the delay; and
 - b. The Contractor establishes, to the satisfaction of the Architect/Engineer, that:
 - i. The delay was caused directly by an act or omission by the owner of the adjoining property; and
 - ii. The Contractor has taken reasonable precautions and has made substantial effort to minimize the delay.
- 6) A Change Order will be furnished to the Contractor within a reasonable period of time, after approval by the BCC, of a request for extension of time, specifying the number of days allowed, if any, and the new dates for completion of the Work or specified portions of the Work. All requests for time extension shall be in accordance with the Contract Documents. With the exception of time extensions covered under the time contingency allowance in the contract, only the BCC shall grant final written approval of all Change Orders, including additional money or extensions of time. All change orders shall be in full accord with the Contract Documents.
- 7) For the proper format to be used in submitting requests or claims for time extensions, refer to applicable sections of the Contract Documents.
- 8) Extensions of time shall be in accordance with Section 9-3 of the Code of Miami-Dade County, as applicable.

D. Substantial Completion and Final Acceptance

- 1) The following items must be satisfied before Substantial Completion, as defined in the Contract Documents, will be approved:
 - a. All Work must be completed to the satisfaction of the appropriate permitting agencies having jurisdiction over the Work. The Contractor must furnish the Owner with a "Certificate of Occupancy" or a "Certificate of Completion", as applicable, from the permitting agency unless circumstances arise outside the contract scope that

prohibits such certificates from being issued (i.e. utility connections).

- b. All operational systems which may include but not be limited to: electrical systems, security systems, irrigation systems and fire systems, must be completed in accordance with the Contract Documents, tested and approved.
 - c. All plumbing, heating, ventilation, and air conditioning systems must be completed, tested and approved. Whenever the scope of work includes a facility or building, an HVAC test and balance report must be submitted and approved as a condition precedent to Substantial Completion.
 - d. The punch list may not be so extensive or of a nature that the Contractor's completion will significantly interfere with the Owner's beneficial use of the facility.
- 2) When the Contractor believes that all the Work or designated portion thereof required by the contract is substantially completed, the Contractor shall submit to the Field Representative and the Architect/Engineer a request for Substantial Completion inspection. The Contractor, the Field Representative, the Architect/Engineer, sub-consultants, and the Owner shall meet at the Project site for the purpose of making a combined inspection of the Work. During this inspection, any item of work remaining to be done or Work to be corrected shall be noted on a Punch List. If the Field Representative and/or the Architect/Engineer and the Owner indicate on this inspection report that the Work is substantially complete, a Certificate of Substantial Completion will be issued to the Contractor. The Certificate of Substantial Completion shall establish the date of Substantial Completion and shall have attached the Punch List reflecting any items to be completed or corrected, but which do not prevent beneficial use and occupancy, and shall state the date by which the Punch List is to be completed. The completion time for the Punch List shall not be greater than sixty (60) days from the date of issuance of the Certificate of Substantial Completion.
- 3) If any of the conditions listed in this article are not met and the Work has not been completed, or the Contractor determines that the final Punch List cannot be completed within sixty (60) days, a Certificate of Substantial Completion shall not be issued. The Contractor shall continue work, reducing the number of items on the Punch List that were not met. Additional inspections shall be scheduled as necessary until Substantial Completion is declared. However, costs incurred by the Owner for any inspections beyond a second inspection will be charged back to the Contractor.
- 4) In the event the Contractor fails to achieve Substantial Completion within the period specified in the Contract for completion, the Contractor shall be liable for Liquidated Damages and the Owner has, as its option, the right to, after ten (10) calendar days notice to the Contractor, have the work performed by others and backcharge the Contractor for all Direct and Indirect Costs related to performing this work. In the event that the Owner chooses to have the work

completed by others, there shall not be any further non-excusable delays charged to the Contractor beyond the ten (10) days following notice to the Contractor. However, the Contractor shall not be relieved of any non-excusable delays incurred through the date of termination. The Punch List and the Contract shall remain open until all the Work is complete and accepted. The current retainage will be used to offset any Liquidated Damages and any backcharges, after which, any surplus retainage will be released to the Contractor. If the retainage is insufficient to cover the Liquidated Damages and any backcharge, the Owner will bill the Contractor for the balance and the Contractor shall promptly remit to the Owner an amount equal to the billing.

- 5) Final Completion: When the Owner or Architect/Engineer considers all Work indicated on the Punch List to be complete, the Contractor shall submit written certification that:
 - a. Work has been inspected for the compliance with the Contract Documents.
 - b. Work has been completed in accordance with the Contract Documents, and that deficiencies listed within the Certificate of Substantial Completion and its attachments have been corrected.
 - c. Work is completed and ready for final inspection.
- 6) Should the Owner and/or Architect/Engineer inspection find that Work is incomplete, he will promptly notify the Contractor in writing listing all observed deficiencies. The Contractor shall be responsible for all Direct and Indirect Costs to the County resulting from the Contractor's failure to complete the Punch List items within the time allowed for completion.
- 7) The Contractor shall remedy deficiencies and send a second certification. Another inspection will be made that shall constitute the final inspection. Provided that work has been satisfactorily completed, the Architect/Engineer will notify the Contractor in writing of Final Acceptance as of the date of this final inspection.
- 8) Prior to Final Acceptance, the Contractor shall deliver to the Field Representative complete As-Builts, all approved Shop Drawings, maintenance manuals, pamphlets, charts, parts lists and specified spare parts, operating instructions and other necessary documents required for all installed materials, equipment, or machinery, all applicable warranties and guarantees, and the appropriate Certificate of Occupancy.
- 9) Upon notification of Final Acceptance to the Contractor, the Architect/Engineer will request and consider closeout submittals from the Contractor including but not limited to the final Contractor's Affidavit and Release of All Claims.
- 10) The Contractor, without prejudice to the terms of the Contract, shall be liable to the Owner for latent defects, fraud, or such gross mistakes as may amount to fraud, or as regards the Owner's rights under any warranty or guaranty.
- 11) Re-Inspection Fees: Should the status of completion of the Work require re-inspection of the Work by the Owner and the Architect/Engineer due to failure

of the Work to comply with the Contractor's representations regarding the completion of the Work, the Owner will deduct from the final payment to the Contractor, fees and costs associated with re-inspection services in addition to scheduled Liquidated Damages.

E. Use and Possession

The Owner shall have the right to beneficially occupy, take possession of or use any completed or partially completed portions of the Work. Such possession or use will not be deemed an acceptance of work not completed in accordance with the Contract. While the Owner is in such possession, the Contractor, notwithstanding the provisions of the Contract Documents, will be relieved of the responsibility for loss or damage to the Work other than that resulting from the Contractor's fault or negligence or breach of warranty. If such prior possession or use by the Owner delays the progress of the Work or causes additional expense to the Contractor, a Contract change in the Contract price or the time of completion will be made and the Contract will be modified in writing accordingly.

F. Liquidated Damages and Liquidated Indirect Costs

- 1) The parties to the Contract agree that time, in the completion of the Work, is of the essence. The Owner and the Contractor recognize and agree that the precise amount of actual damages for delay in the performance and completion of the Work is impossible to determine as of the date of execution of the Contract and that proof of the precise amount will be difficult. Therefore, the Contractor shall be assessed Liquidated Damages on a daily basis for each Day that individual milestones, both interim and cumulative as specified in the Contract Documents, are not timely achieved or that Contract Time is exceeded due to a non-excusable delay. These Liquidated Damages shall be assessed, not as a penalty, but as compensation to the Owner for expenses which are difficult to quantify with any certainty and which were incurred by the Owner due to the delay. The amount of Liquidated Damages assessed shall be an amount, as stipulated in the Contract Documents, per day for each calendar day that individual milestones as specified in the Contract are not timely achieved or that the Project is delayed due to a non-excusable delay.
- 2) The Owner and the Contractor recognize and agree that the precise amount of the Contractor's Indirect Costs for delay in the performance and completion of the Work is impossible to determine as of the date of execution of the Contract, and that proof of the precise amount will be difficult. Therefore, Liquidated Indirect Costs recoverable by the Contractor shall be assessed on a daily basis for each Day the Contract Time is delayed due to compensable delay. These Liquidated Indirect Costs shall be paid to the Contractor in full satisfaction of all costs and damages caused by compensable excusable delays, except for Direct Costs. There shall be no Liquidated Indirect Costs payable for time directly related to Extra Work for which a Change Order has been issued.
- 3) The amount of Liquidated Indirect Costs recoverable shall be an amount, as stipulated in the Contract Documents per day for each day the Contract is delayed due to compensable excusable delay. For lump sum contracts, the daily amount of Liquidated Indirect Costs will be calculated by dividing the total

amount in the Contractor's approved Schedule of Values for General Requirements by the Contract duration (in days) after deducting any general conditions costs directly paid by the Owner during the execution of the Project. The amount of the Liquidated Indirect Costs calculated in accordance with this formula shall be stated in the Notice-to-Proceed. For unit price contracts, the daily amount of Liquidated Indirect Costs will be calculated as defined in the formula below:

- 4) In the event the Contractor fails to perform any other covenant or condition (other than time-related) of this Contract relating to the Work, the Contractor shall become liable to the Owner for any actual damages which the Owner may sustain as a result of such failure on the part of the Contractor. The Owner reserves the right to retain these amounts from monies due the Contractor.
- 5) Nothing in this article shall be construed as limiting the right of the Owner to terminate the Contract and/or to require the Surety to complete said Project and/or to claim damages for the failure of the Contractor to abide by each and every one of the terms of this Contract as set forth and provided for in the Contract Documents.

END OF ARTICLE

9. PROGRESS PAYMENTS

(June 12, 2012)

A. Payments

- 1) The Contractor shall receive and accept compensation provided for in the Contract as full payment for furnishing all materials, for performing all work under the Contract in a complete and acceptable manner, and for all risk, loss, damage, or expense of whatever character arising out of the nature of the work or the prosecution thereof.
- 2) The Owner will make progress payments monthly as the work proceeds. Unless the Special Provisions provide for the payment to be determined by using a cost-loaded CPM, the Contractor shall, within 15 days after Notice-to-Proceed, furnish a Schedule of Values for review and approval by the Owner consisting of a detailed cost breakdown of each lump sum bid item in the bid form in such detail as the Architect/Engineer shall request, showing the amount included therein for each principal category of the work, to provide the basis for determining the amount of progress payments. Unit price bid items shall be paid for in accordance with the Bid Form. The Schedule of Values shall clearly indicate the amount to be paid by the Contractor to each individual Subcontractor.
 - a. The unit prices shall be in proper balance and shall be subject to approval by the Owner. In the preparation of estimates, the Owner, at its sole discretion, may authorize material delivered on the site and preparatory work done to be taken into consideration. Material delivered to the Contractor at locations other than the Work Site may also be taken into consideration under this article when the Contractor furnishes satisfactory evidence that it will be utilized on the work covered by this Contract.
- 3) In making such progress payments, a maximum of ten-percent (5%) or a minimum of five-percent (2.5%), as may be amended in the Contract Documents, of the estimated amount shall be retained from each progress payment made to the Contractor until Fifty-Percent (50%) Completion of the work has been established. Fifty-Percent (50%) completion is defined as the point in time when at least 50% of the Work under contract has been physically and satisfactorily completed in accordance with the intent of the Contract Documents as determined by the Architect/Engineer. At this point, the retainage amount withheld from each subsequent progress payment shall be reduced by 50% or not to exceed five-percent (2.5%) and the accumulated excess amount of retainage will be released to the Contractor, unless such amount is the subject of a good faith dispute, the subject of a claim brought pursuant to Florida Statute 255.05, or otherwise the subject of a claim or demand by the Owner or Contractor. If, at the discretion of the Owner, any time after Fifty-Percent (50%) Completion of the work has been established, the Owner finds

that satisfactory progress is being made, it may authorize any of the remaining progress payments to be made in full. Also, whenever the Work is Substantially Complete, the Owner, if it considers the amount retained to be in excess of the amount adequate for its protection, may release to the Contractor all or a portion of such excess amount.

- 4) Material and work covered by progress payments shall become the sole property of the Owner. This provision shall not be construed as relieving the Contractor from the sole responsibility for material and work upon which payments have been made, the restoration of damaged work or as waiving the right of the Owner to require the fulfillment of the terms of the Contract.
- 5) Progress payments will be made in accordance with the Miami-Dade County Code, Florida Statute, s. 218.70 Florida Prompt Payment Act, and Florida Statute, s. 218.735.
 - a. The Contractor's attention is directed to Florida Statute, s. 218.735, revising provisions regarding timely payment, revising deadlines for the payment of contractors, subcontractors, sub-subcontractors, material-men and suppliers. The contractor shall remit payment due to subcontractors within ten (10) days after the contractors' receipt of payment. The subcontractor shall remit payment due to sub-subcontractors and suppliers within seven (7) days after the subcontractors' receipt of payment. Dispute resolution is provided within the Statute.
- 6) No progress payments will knowingly be made for work not in accordance with this Contract.
- 7) Applications for progress payments shall be in the format as prescribed by the Owner. These applications shall be supported by evidence, which is required by this article. Each application for payment shall clearly indicate the amount to be paid to the Contractor as well as the amount to be paid to each of the Contractor's Subcontractors and suppliers. The Contractor shall certify that the work for which payment is requested has been done and that the materials listed are stored where indicated. Those items on the progress payment application that, in accordance with the applicable sections of the Contract Documents, compensate for Force Account Work, for materials not yet incorporated in the work, or for work under change orders negotiated on a cost-reimbursable basis will, under procedures of the Owner, be subject to the Owner's audit review of the Contractor's records supporting the payment application. Audits will be performed so as not to interfere with timely processing of applications for payment. If audit indicates the Contractor has been overpaid under a previous payment application, that overpayment will be credited against current progress payment applications. For a period of five years from Final Acceptance of the Contract, the Contractor shall maintain and make available for audit inspection and copying by the Owner, State and the Government and their authorized representatives, all records subject to audit review.

- 8) The Owner, at its discretion, may authorize payment for materials not yet incorporated into the Work, whether or not delivered to the Work Site. The value of materials on hand but not incorporated into the Work will be determined by the Field Representative, based on actual invoice costs to the Contractor, and such value will be included in a monthly application for payment only if the materials have been properly stored on the Site, provided that such materials meet the requirements of the Contract Documents, and are delivered to acceptable locations on Site or in bonded warehouses that are acceptable to the Owner. Such delivered costs of stored or stockpiled materials may be included in the next application for payment after the following conditions are met:
- a. The material has been stored and stockpiled in a manner acceptable to the Field Representative at or on the Work site or in a secure storage facility within Miami-Dade County or other location as approved by the Architect/Engineer. If such materials are stored outside Miami-Dade County, the Contractor shall accept responsibility for and pay all personal and property taxes that may be levied against the Owner by any state or subdivision thereof on account of such storage of such material. The Owner will permit the Contractor, at his own expense, to contest the validity of any such tax levied against the Owner and in the event of any judgment or decree of a court against the Owner, the Contractor agrees to pay same.
 - b. The Contractor has furnished the Field Representative with acceptable evidence of the quantity and quality of such stored or stockpiled materials.
 - c. The Contractor has furnished the Field Representative with satisfactory evidence that the materials and transportation costs have been paid including but not limited to certified bills of sale for such materials and insurance certificates or other instruments, in writing, and in a form as required by the Owner. The Architect/Engineer may allow only such portion of the amount represented by these bills as, in his opinion, is consistent with the reasonable cost of such materials.
 - d. The Contractor has furnished the Owner legal title (free of debts, claims, liens, mortgages, taxes or encumbrances of any kind) to the material so stored and stockpiled and subject only to the Owner's payment for the materials as reflected in the application for payment. All such materials so accepted shall become the property of the Owner. The Contractor at his own expense shall mark such material as the property of the Owner and shall take such other steps, if any, the Owner may require or regard as necessary to vest title in the Owner to such material.
 - e. The Contractor has furnished the Owner evidence that the material so stored or stockpiled is insured against loss by damage to or

disappearance of such materials at any time prior to use in the work. The cost of the material included in an application for payment which may subsequently become lost, damaged or unsatisfactory shall be deducted from succeeding applications for payment irrespective of the cause and whether or not due to the negligence, carelessness or fault of the Owner.

- f. It is understood and agreed that the transfer of title and the Owner's payment for such stored or stockpiled materials shall in no way relieve the Contractor of its responsibility for furnishing and placing such materials in accordance with the requirements of the Contract Documents and does not waive Owner's right to reject defective material when it is delivered to the Site until such material is delivered to the Site and satisfactorily incorporated into the work.
 - g. In no case will the amount in an application for payment for material on hand exceed the Contract price for such material, the Contract price for the Contract item in which the material is intended to be used or the value for such material established in the approved Schedule of Values. Payment for material furnished and delivered as indicated above will be based on 100 percent of the cost to the Contractor and retention will be withheld as specified in the Contract Documents. In any event, partial payments for materials on hand will not exceed seventy percent (70%) of the item's Bid Price, including taxes and shipping, or the agreed amount within the Schedule of Values.
 - h. No partial payment will be made for stored or stockpiled living or perishable plant materials.
 - i. The Contractor shall bear all costs associated with the partial payment of stored or stockpiled materials in accordance with the provisions of this Article.
 - j. Materials may be subject to being purchased by the Owner directly under the County's "Direct Material Purchase Program" and installed by the Contractor, as applicable, in accordance with the Special Provisions.
- 9) Payment of the Contract lump sum price for General Requirements, if applicable, will be made in the following manner:
- a. The General Requirements Lump Sum amount, including cost for bonds and insurance, shall be paid in proportion to the total percent of completion. The Owner will consider requests for payment for bonds and insurance under the General Requirements after receipt of certified invoices from the Contractor showing that the Contractor has paid them.

- b. The Owner reserves its right to withhold payment for General Requirements, in whole or in part, at the Owner's sole discretion, in accordance with Paragraph 11 below.
- 10) If any claim is filed against the project for labor, materials, supplies or equipment which the Owner has determined to have been incorporated on the site and the Contractor has not paid for, the Owner will have the right to retain from payments otherwise due the Contractor, in addition to other amounts properly withheld under this article or under other provisions of the Contract, an amount equal to such amounts claimed.
- 11) In addition to the provisions of this article and other relevant sections of the Contract Documents, payment may also be withheld proportionately for the following reasons:
- a. Reasonable doubt that the Work can be completed for the unpaid balance of the Contract Sum,
 - b. Reasonable indication that the Work will not be completed within the Contract Time,
 - c. Damage to another Contractor,
 - d. Unsatisfactory prosecution of the Work by the Contractor,
 - e. Failure of the Contractor, or his Subcontractors, to pay wage rates, when applicable as required by the Contract.
 - f. In the event the Surety on the Performance and Payment Bond provided by the Contractor becomes insolvent, or is placed in the hands of a receiver, or has its right to do business in the State of Florida suspended or revoked as provided by law. In this case, payment will continue when the Contractor provides a good and sufficient Bond(s) as required by the Contract Documents, in lieu of the Bond(s) so executed by such Surety.
 - g. If any work or material is discovered which, in the opinion of either the Architect/Engineer or the Field Representative, is defective, or should a reasonable doubt arise on the part of the either the Architect/Engineer or the Field Representative as to the integrity of any part of the work completed previous to the final acceptance and payment. In this case, there will be deducted from the first application for payment subsequent to the discovery of such work, an amount equal in value to the defective or questioned work, and this work will not be included in any subsequent applications for payment until the defects have been remedied or the causes for doubt removed.
- 12) The Contractor shall submit with each monthly invoice the certified payroll forms for all employees on the job in accordance with applicable Responsible Wages and Benefits (Ordinance No. 90-143 and codified in Miami-Dade County Code Section 2-11.16). Failure to provide this information will cause

the Field Representative and/or Architect/Engineer to return the invoice to the Contractor until such time as the Contractor properly submits the information.

- 13) Failure to comply with the insurance requirements listed in the Contract Documents may result in the Owner's withholding or delaying payment to the Contractor.

B. Taxes

- 1) Except as may be otherwise provided for in the Contract Documents, the price or prices bid for the Work shall include full compensation for all federal, state, local and foreign taxes, fees and duties that the Contractor is or may be required to pay and the Contractor shall be responsible for the payment thereof during the prosecution of the work.
- 2) The Contractor's attention is directed to the fact that materials and supplies necessary for the completion of this Contract are subject to the Florida Sales and Use Tax, in accordance with Section 212.08, Florida Statutes, as amended. The Contractor shall not collect taxes upon making delivery to the Owner.
- 3) The Owner, at its sole discretion, upon request of the Contractor and where appropriate, may furnish to the Contractor appropriate evidence to establish exemption from any taxes, fees or duties which may be applicable to the agreement and from which the Owner is exempt.

C. Payments to Subcontractors and Suppliers

- 1) The Contractor shall pay all Subcontractors for and on account of work performed by such Subcontractors in accordance with the terms of their respective subcontracts and in accordance with Ordinance Nos. 94-40, and 02-29, Miami-Dade County Code Section 10-33.02 and Florida Statute s. 218.735.
- 2) Before the Contractor can receive any payment, except the first payment, for monies due him as a result of a percentage of the work completed, he must provide the Architect/Engineer with duly executed release of claim from all subcontractors and suppliers who have performed any work or supplied any material on the project as of the date, stating that said subcontractors or suppliers have been paid their proportionate share of all previous payments. In the event such affidavits cannot be furnished, the Contractor may, at the Owner's sole discretion after the Contractor demonstrates justifiable reasons, submit an executed Consent of Surety to Requisition using the form provided in the Contract Documents identifying the subcontractors and the amounts for which the Statement of Satisfaction cannot be furnished.
- 3) The Contractor's failure to provide a Consent of Surety to Requisition Payment will result in the amount in dispute being withheld until (1) the Statement of Satisfaction is furnished, or (2) Consent of Surety to Requisition Payment is furnished. The Subcontractor(s) shall submit with each monthly invoice the Certified Payroll forms for all employees on the job in accordance with applicable Provisions. Failure to provide this information will cause the Architect/Engineer to return the invoice to the Contractor until such time as the Contractor properly submits the information.

D. Contract Prices – Bid Form

- 1) Payment for the various Bid Items listed in the Bid Form shall constitute full compensation for furnishing plant, labor, equipment, appliances and materials and for performing operations required to complete the Work in conformity with the Contract Documents. All costs for work shown or indicated by the Contract Documents, although not specifically provided for by a Bid Item in the Bid Form, shall be included in the most appropriate Bid Item price for the items listed. Except for the relief provided by the applicable section of the Contract Documents governing Differing Site Conditions, the Contractor will not be entitled to additional compensation for providing an activity or material necessary for the completion of the Work in accordance with the Contract even though the activity or material is not included in a specific Bid Item or indicated in the Contract Documents.

E. Final Payment

- 1) After the Work has been accepted by the Owner, subject to the provisions of the Contract Documents, a final payment will be made as follows:
 - a. Prior to Final Acceptance of the Work, the Contractor shall prepare and submit a proposed final application for payment to the Architect/Engineer showing the proposed total amount due the Contractor, segregated as to Bid Item quantities, force account work, and other bases for payments; deductions made or to be made for prior payment; amounts to be retained; any claims the Contractor intends to file at that time or a statement that no claims will be filed; and any unsettled claims, stating amounts. Prior applications and payments shall be subject to correction in the proposed final application for payment. Claims filed with the final application for payment must be otherwise timely under these General Conditions.
 - b. The Owner will review the Contractor's proposed final application for payment and necessary changes or corrections will be forwarded to the Contractor. Within 10 days thereafter, the Contractor shall submit a final application for payment incorporating changes or corrections made by the Architect/Engineer together with additional claims resulting therefrom. Upon approval by the Owner, the corrected proposed final application for payment will become the approved final application for payment.
 - c. If the Contractor files no claims with the final application for payment and no claims remain unsettled within 30 days after final inspection of the Work by the Architect/Engineer and the Owner, and agreements are reached on all questions regarding the final application for payment, the Owner, in exchange for an executed release of all claims and properly executed close-out documents specified in Paragraph 3 below, will pay the entire sum found due on the approved final application for payment.
 - d. Upon final determination of any and all claims, the Owner, in exchange for properly executed close-out documents specified in

Paragraph 3 below, will pay the entire sum found due on the approved final application for payment, including the amount, if any, allowed on claims.

- e. The release from the Contractor will be from any claims arising from the Work under the Contract. If the Contractor's claim to amounts payable under the Contract has been authorized by the Owner for assignment pursuant to the relevant sections of the Contract Documents, a release may be required from the assignee.
 - f. Final payment will be made within 30 days after approval of the final notice and resolution of Contractor's claims, or 30 days after Final Acceptance of the Work by the Owner, whichever is later. If a final application for payment has not been approved within 30 days after final inspection of the Work, the Owner shall make payment of sums not in dispute without prejudice to the rights of either the Owner or the Contractor in connection with any disputed items.
 - g. Prior to payment of a claim settlement, the claim may be audited by the Owner and may be subject to approval by the funding agencies.
 - h. Final payment made in accordance with this article will be conclusive and binding against both parties to the Contract on all questions relating to the amount of work done and the compensation paid therefore.
- 2) With the final application for payment, the Contractor shall return and submit final releases of claim from himself, from each Subcontractor of record and from other Subcontractors or material suppliers who may have notified the Owner that they were furnishing labor or materials for this project. These releases from Subcontractors and suppliers shall be final, originals, notarized and executed on the form provided by the Owner and included in the Contract Documents, all in accordance with all applicable Florida Statutes. In addition, the Contractor shall execute and return to the Owner all the enclosed close-out documents. In the event that all of the above releases cannot be furnished, the Contractor may, at the Owner's sole discretion after the Contractor demonstrates justifiable reasons, submit a Consent of Surety to Final Payment in a form acceptable to the Owner, recognizing lack of such releases of claim. Furthermore, the Contractor and the Surety shall agree in writing, in a form acceptable to the Owner, to indemnify, defend and hold harmless the Owner from any claims of Subcontractors and suppliers who refuse to execute final releases.
- 3) The making of final payment shall constitute a waiver of all claims by the Owner except those arising from:
- a. Faulty or defective Work appearing after Final Completion;
 - b. Failure of the Work to comply with the requirements of the Contract Documents, discovered after Final Completion;

- c. The performance of audits to seek reimbursement of any overpayments discovered as a result of an audit as provided in the Contract Documents;
 - d. The enforcement of those provisions of the Contract Documents which specifically provide that they survive the completion of the Work;
 - e. The enforcement of the terms of the Payment and Performance Bonds against the Surety;
 - f. Terms of all warranties/guarantees required by the Contract Documents.
- 4) The acceptance of final payment shall constitute a waiver of all claims by the Contractor.

END OF ARTICLE

10. CHANGES

(June 12, 2012)

A. Changes

- 1) The Owner reserves the right to, at any time, without notice to the sureties and without invalidating the Contract, by written notice or order designated as a Change Notice or Change Order, make any change in the Work within the general scope of the Contract including but not limited to changes:
 - a. In the Contract Documents;
 - b. In the method or manner of performance of the Work;
 - c. In Owner-furnished facilities, equipment, materials, services, or site or;
 - d. Directing acceleration in performance of the Work.
- 2) In the event the Owner exercises its right to change, delete or add work under the Contract, such work will be ordered and paid for as provided for in the Contract Documents.
- 3) Changes in the work may be initiated by the issuance of a Change Notice by the Architect/Engineer. The Contractor shall submit a proposal to the Architect/Engineer and the Owner for their review, in accordance with the Contract Documents, within a reasonable time after receipt of a Change Notice. The Contractor shall maintain this proposal, for acceptance by the Owner, for a minimum of 90 calendar days after submittal. The cost or credit to the Owner for any change in the work shall be determined in accordance with the provisions of the Contract Documents. The Contractor shall not be compensated for effort expended in preparing and submitting price quotes.
- 4) In the event the Contractor fails to provide the full cost and time estimate for the change work or refuses to execute a full accord Change Order, the Owner will, at its sole discretion, (1) determine the total cost and time impacts of the change and compensate the Contractor and/or extend the Contract Time, if applicable, through a unilateral Change Order signed only by the Owner; or (2) direct the Contractor to proceed with the Work under the Force Account provisions of this article. Failure of the Contractor to submit his total and final estimated cost and time impact within the time period specified on the Change Notice form shall constitute a waiver by the Contractor to claim additional costs or time beyond that which has been determined by the Owner. Any disputes arising out of an Owner determination shall be resolved in accordance with the disputes provisions in the Contract Documents. Pending the Owner's final decision, the Contractor shall proceed diligently with the performance of the Work under the Contract.
- 5) Changes in the work covered by Unit Prices, as stated in the Contract Documents shall be all inclusive. These prices will include all Direct and Indirect Costs and means and methods of execution. To be compensable, units

must be measured daily by the Contractor and approved in writing by the Owner or his authorized representative.

- 6) The following mark-ups on Extra Work shall apply to all changes in the Work performed under this article:
 - a. For Extra Work performed by the Contractor's own forces, the Contractor agrees that his proposed cost to perform said Extra Work will in no event include a rate for overhead in excess of fifteen percent (15%).
 - b. For Extra Work performed by a Subcontractor's forces, the Contractor agrees that his proposed cost to perform said Extra Work will in no event include Overhead in excess of fifteen percent (15%). The Contractor may then add five percent (5%) times the Subcontractor's or sub-tier Subcontractor's actual Direct Cost as direct compensation for the Contractor's Overhead and all other costs associated with the Subcontractors Work at all tiers.
- 7) Increases to the Contract Amount shall be authorized by a Change Order executed by the Contractor, the Contractor's Surety and the Owner and approved by the BCC. Decreases to the Contract amount shall be by Change Order or Work Order as determined by the Owner and shall also be subject to BCC approval when the decrease results from a reduction in the scope of the work.
- 8) A cost of bonds for Change Orders that impact the Contract price shall be established by the Contractor's actual reimbursement costs, as approved by the Owner, based on the original Contract Amount and the original amount reimbursed to the Contractor for bonds at the commencement of the Work. This cost of bonds shall be added to all credit amounts allowed by the Owner. For Change Orders paid under the Allowance Account, no additional bond cost will be allowed unless the Allowance Account is not included in the original Contract Amount. In this case, additional bond costs for these Change Orders will be considered.
- 9) Any claim for payment of Extra Work that is not covered by a Change Order or Work Order will be rejected by the Owner.

B. Allowance Accounts

- 1) Certain portions of work which may be required to be performed by the Contractor under this Contract are either unforeseeable or have not yet been designed, and the value of such work, if any, is included in the Contract as a specific line item(s) entitled "Allowance Account(s)".
 - a. The Allowance Account (General) can be used to reimburse the Contractor for (1) furnishing all labor, materials, equipment and services necessary for modifications or Extra Work required to complete the Project because of unforeseeable conditions and; (2) for performing construction changes required to resolve: oversight in design, Owner oversight, unforeseen conditions, revised regulations, technological and product development, operational changes,

schedule requirements, program interface, emergencies and delays; and for making final adjustment to estimated quantities shown on the Schedule of Values or amounts bid in the Bid Form to conform to actual quantities installed.

- b. Other Allowance Account(s) (Dedicated) may be used as specified in the Contract Documents to fund specific items of work at the sole discretion of the Owner. These dedicated allowance accounts shall be used only for the purposes approved pursuant to a written Work Order issued by the Owner or his authorized representative.
- 2) At such time as work is to be performed under the Allowance Account(s), if any, the work shall be incorporated into the Schedule and the Schedule of Values, and shall in all respects be integrated into the construction as a part of the Contract as awarded.
 - 3) The Work Order for the required work will be issued by the Owner or Architect/Engineer upon receipt from the Contractor of a satisfactory proposal for performance of the work, and the acceptance thereof by the Architect/Engineer and the Owner. If the Contractor and the Owner are unable to agree upon an amount of compensation or; if the nature of the work is such that a Unit Price or Lump Sum price is not economically practical or if the change work is deemed essential to the Project and actual conditions require work to be swiftly conducted to avoid or minimize delays, the Work Order may be issued to perform the work on a Force Account basis. In the event that an equitable adjustment for the said change work cannot be arrived at, either by mutual agreement or under the dispute provisions of the Contract Documents, the compensation hereunder will be the total compensation for this work.
 - 4) No Work Orders shall be issued against an Allowance Account if such Work Orders in the aggregate exceed the authorized amount of that Allowance Account, provided however that such excess may be authorized by appropriate Change Order.
 - 5) The unexpended amounts under the allowance accounts shall remain with the Owner and the Contractor shall have no claim to the same.

C. Deletion or Addition of Work

- 1) In the event the Owner exercises its right to delete any portion(s) of the work contemplated herein, such deletion will be ordered and the Contract Total Amount and Time may be adjusted as provided for in these Contract Documents by Change Order or by Work Order, as appropriate. The Contractor shall be reimbursed for any actual reasonable expenses incurred prior to the notice of deletion of work as a result of preparing to perform the work deleted. In the event of a dispute between Owner and Contractor as to the adjustment to the amount of time, the dispute shall be handled in accordance with these General Conditions.
- 2) Deleted Work - Lump Sum Bid Item(s): The Contractor shall credit the Owner for the reasonable value of the deleted work determined from the approved Schedule of Values, subject to approval by the Architect/Engineer. If the reasonable value of the deleted work cannot be readily ascertained from the

Schedule of Values submitted in accordance with these General Conditions, or if requested by the Architect/Engineer, the Contractor shall supply all data required by the Architect/Engineer, including the actual agreements executed by the Contractor with the Subcontractors and suppliers affected by the deleted work, to substantiate the amount of the credit to be given the Owner. The Contractor shall also submit for the Owner's approval a revised schedule of values reflecting the work remaining under the Contract following the deletion.

- 3) No payment(s) shall be made to the Contractor by the Owner for loss of anticipated profit(s) from any deleted work.
- 4) In the event the Owner exercises its right to add to any portion of the work contemplated herein, such addition will be ordered and the Contract Total Amount and Contract Time will be adjusted as provided for in these Contract Documents, by Change Order or by Work Order as appropriate. In the event of a dispute between Owner and Contractor as to the adjustment to the Amount or the Time, the dispute shall be handled in accordance with the Contract Documents.

D. Increased or Decreased Quantities (Unit Prices)

- 1) This section applies to Owner-initiated additions or deletions from the Work and to the unit prices contained within this contract and controls payments or credits for variations between estimated and actual quantities required to complete the Work, even though the additions or deletions may be distinct or separate structures or activities and regardless of the fact that the addition or deletion is a result of field adjustments, site conditions, a design change or any other cause. Increases or decreases will be determined by comparing the actual quantity required to the Architect/Engineer's estimated quantity in the Bid Form.
- 2) If the actual quantity of Bid Item varies from the Architect/Engineer's quantity estimate by 25% or less, payment for the Bid Item will be made at the Contract unit price. If the actual quantity varies from the Bid quantity by more than 25%, the compensation payable to the Contractor will be the subject of review by the Contractor and the Architect/Engineer and a Contract adjustment will be made by means of a Change Order in accordance with the Contract Documents to credit the Owner with any reduction in unit prices or to compensate the Contractor for any increase in unit price resulting from variations between estimated and actual quantities. The unit price to be re-negotiated shall be only for that quantity above 125% or below 75% of the original bid quantities.
- 3) The Contractor shall submit to the Architect/Engineer all data required to substantiate the amount of compensation requested therefore. In no event shall the Contractor be entitled to compensation greater than the aggregate amount of all the Unit Prices times the original bid quantities of Work reflected in the Bid Form.
- 4) No compensation will be made in any case for loss of anticipatory profits, loss of bonding capacity or consequential damages.

E. Extra Work

- 1) Except as otherwise expressly provided above, all additional work ordered, work changed or work deleted shall be authorized by Work Order(s) or Change Order(s). All changed or added work so authorized shall be performed by the Contractor at the time and in the manner specified.

The Change Order shall include, as a minimum:

- a. Scope of work to be added, deleted or modified;
- b. Cost of work to be added, deleted or modified;
- c. The Contract time extension or reduction in contract time in the case of deleted work required to perform the work to be added, deleted or modified;
- d. Full release of claims associated with the Contract through the date of the change order, or a reservation of claims identified as to each claim reserved, the scope of the work, the maximum cost of the work, and the maximum number of days of Contract time requested, shall be specified.

The Work Order shall include, at a minimum:

- a. Scope of work to be added, deleted or modified;
- b. Cost of work to be added, deleted or modified;
- c. The Contract time extension required to perform the work to be added, deleted or modified;
- d. Full release of claims associated with the work order work, or a reservation of claims identified as to each claim reserved, the scope of the work, the maximum cost of the work, and the maximum number of days of Contract time requested, shall be specified.

- 2) If Work is ordered, changed, or deleted which is not covered by Unit Prices, then, the Owner and the Contractor shall negotiate an equitable adjustment to the Contract Price for the Direct Costs for the performance of such work in accordance with this article. Indirect Costs for Work ordered, changed or deleted may be reimbursed for Excusable and Compensable Delay as defined in these Contract Documents.

- a. In order to reimburse the Contractor for additional Direct Costs, either by Work Order, Change Order or any other means, the Contractor must have additional work added to the Contract Scope of Work. The additional cost of idle or inefficient labor, from any cause, or the additional cost of labor made idle or inefficient from any cause will not be considered a reimbursable additional Direct Cost. Special equipment or machinery, which is made idle or inefficient by the Work ordered, changed or deleted, may be reimbursable if approved by the Architect/Engineer as an unavoidable cost to the Contractor, caused by the Owner.

- b. Costs of special equipment or machinery, not already mobilized on the site, approved by the Architect/Engineer, shall be calculated using the current issue of the Associated Equipment Distributors (AED) Manual plus any required mobilization. The selection of which of the AED rates (daily, weekly, monthly) to be used to calculate these costs shall be as follows:
 - i. Between one (1) day and seven (7) days, use the daily rate.
 - ii. Between seven (7) days and thirty (30) days, use the weekly rate.
 - iii. Greater than thirty (30) days, use the monthly rate.
- c. For less than one (1) day hourly rates, use the daily rate divided by eight (8).
- d. For overtime hourly rates use the daily rate divided by eight (8), the weekly rate divided by forty (40), or the monthly rate divided by one hundred and seventy-six (176) as appropriate.
- e. Costs for Special Equipment and Machinery already mobilized on the site, shall not exceed the monthly rate stated in the AED Manual, divided by one hundred and seventy-six (176), per hour that the Special Equipment and Machinery is in use on the work plus any required re-mobilization.
- f. The cost calculation shall not combine rates within the range of a time extension. It shall use decimals of the time extension rate that the extension falls under. For example, the cost calculation for a piece of Special Equipment with an approved delay of forty five (45) days shall be one and one-half (1.5) months times the monthly rate, not one (1) month at the monthly rate, plus two (2) weeks at the weekly rate, plus one (1) day at the daily rate.
- g. Rental for special equipment and machinery, not already mobilized to the site, shall be an amount equal to the appropriate daily, weekly, or monthly rental rate for such equipment, in accordance with the current issue of Associated Equipment Distributors' (AED) "Compilation of Nationally Averaged Rental Rates and Model Specifications for Construction Equipment" (notwithstanding the caveats contained therein that such rental rates are not for use by government agencies) for each and every rental period (in weeks, days, or months as applicable) that the special equipment or machinery is in use on the work plus any required mobilization. Payment for special equipment and machinery already mobilized to the site shall not exceed the monthly rate stated in the AED standards divided by one hundred and seventy six (176) to establish a per hour rate that the special equipment and machinery is in use on the Work, plus any required re-mobilization.
- h. For indirect costs, the Contractor shall be allowed a percentage mark-up as set forth in Paragraph G. 2 below.

F. Differing Site Conditions

- 1) The Contractor shall immediately, and before such conditions are disturbed, notify the Architect/Engineer in writing of: (1) subsurface or latent physical conditions at the site differing materially from those indicated in the Contract Documents, or (2) unknown physical conditions at the site, of an unusual nature, differing materially from those ordinarily encountered and generally recognized as inherent in work of the character provided for in the Contract.
- 2) The Architect/Engineer will promptly investigate the conditions, and if such conditions materially differ and cause an increase or decrease in the Contractor's cost of, or the time required for, performance of any part of the work under the Contract, a Contract change may be made and the Contract modified in writing in accordance with the Contract Documents.
- 3) No claim of the Contractor under this article will be allowed unless the Contractor has given the notice required in the Contract Documents.
- 4) No claim by the Contractor for a Contract change hereunder will be allowed if asserted after final payment under this Contract.
- 5) If the Owner is not given written notice prior to the conditions being disturbed, the Contractor will be deemed to have waived his right to assert a claim for additional time and compensation arising out of such changed conditions.

G. Force Account

- 1) If the Owner and the Contractor cannot reach agreement on an equitable adjustment to the Contract Price for any work as prescribed above, then the Extra Work will be performed on a Force Account basis as directed by the Architect/Engineer and paid for as specified below.
- 2) The following percentages will be allowed as mark-ups over Direct Costs for all negotiated adjustments to the Contract Amount or for work performed on either a negotiated lump sum basis or a Force Account basis:
 - a. Extra Work Performed directly by Contractor's Own Forces: The Contractor may add up to a maximum fifteen percent (15%) mark-up on the actual Direct Cost of the Extra Work, subject to review and approval by the Architect/Engineer, as direct compensation for Overhead. A 10% mark-up will be added to all negotiated credit amounts for deleted work not performed to cover Overhead.
 - b. Extra Work Performed by a Subcontractor or any Sub-tier Subcontractor: The Subcontractor may add up to a maximum fifteen percent (15%) mark-up on the actual Direct Cost of the Extra Work as direct compensation for Overhead. The Contractor may add a five percent (5%) mark-up on the Subcontractor's actual Direct Cost as Contractor's Overhead. A 10% additional credit will be added to all Subcontractor negotiated credit amounts for deleted work not performed to cover quality control, supervision, coordination, overhead, small tools and incidentals.

3) In the event Extra Work is performed on a Force Account basis, then the Contractor and the Subcontractor(s), as appropriate, shall maintain itemized daily records of costs, quantities, labor and the use of authorized Special Equipment or Machinery. Copies of such records, maintained as follows, shall be furnished to the Architect/Engineer daily for approval, subject to audit.

a. Comparison of Record: The Contractor, including its Subcontractor(s) of any tier performing the work, and the Architect/Engineer shall compare records of the cost of force account work at the end of each day. Agreement shall be indicated by signature of the Contractor, the Subcontractor performing the work, and the Architect/Engineer or their duly authorized representatives.

b. Statement: No payment will be made for work performed on a force account basis until the Contractor has furnished the Architect/Engineer with duplicate itemized statements of the cost of such force account work detailed as follows:

i. Name, classification, date, daily hours, total hours, rate and extension for each laborer, tradesman, and foreman.

ii. Designation, dates, daily hours, total hours, rental rate, and extension of each unit of special machinery and equipment.

iii. Quantities of materials, prices, and extensions.

iv. Transportation of materials.

The statements shall be accompanied and supported by a receipted invoice of all materials used and transportation charges. However, if materials used on the force account work are not specifically purchased for such work but are taken from the Contractor's stock, then in lieu of the invoices the Contractor shall furnish an affidavit certifying that such materials were taken from its stock, that the quantity claimed was actually used, and that the price and transportation claimed represent the actual cost to the Contractor.

c. Authorization of Special Equipment and Machinery: No compensation for special equipment or machinery shall be made without written authorization from the Architect/Engineer. The Architect/Engineer shall review and evaluate any special equipment or machinery proposed by the Contractor for use on a force account basis. As part of its evaluation, the Architect/Engineer shall determine whether any of the special equipment or machinery being proposed by the Contractor will be concurrently used on the Project, including approved changes, or on other force account work on the Project. If the Architect/Engineer determines that such a concurrent use of special equipment or machinery is being proposed by the Contractor, prior to the authorization of such special equipment or machinery, the Architect/Engineer and thereto Contractor shall establish a straight-line prorated billing mechanism based on the

actual percentage of time that the equipment or machinery is required to be used on the force account work(s).

Special equipment or machinery which is approved for use by the Architect/Engineer shall be reviewed and accounted for on a daily basis as provided in the Comparison of Record and Statement paragraphs of this section of the Contract.

- d. Inefficiency in the Prosecution of the Work: If in the Owner's or Architect/Engineer's opinion, the Contractor or any of its Subcontractors, in performing Force Account Work, is not making efficient use of labor, materials or equipment or is proceeding in a manner which makes Force Account Work unnecessarily more expensive to the Owner, the Owner or Architect/Engineer may, in whole or part, direct the Contractor in the deployment of labor, material and equipment. By way of illustration, inefficiency may arise in the following ways, including but not limited to: (1) the timing of the Work, (2) the use of unnecessary labor or equipment, (3) the use of a higher percentage of journeymen than in non-force account Work, (4) the failure to procure materials at lowest price, or (5) using materials of quality higher than necessary.

H. Contractor Proposals - General

- 1) The Contractor may at any time submit to the Architect/Engineer for his review proposed modifications to the Contract Documents, including but not limited to, changes in the Contract Time and/or Contract Amount, supported by a cost/price proposal. Upon acceptance of the proposed modifications by the Owner, a Work Order or Change Order will be issued. Denial of a proposed modification will neither provide the Contractor with any basis for claim for damages nor release the Contractor from contractual responsibilities. A Contract change in the form of a Contract price reduction will be made if the change results in a reduction of the cost of performance and the Contractor will not be entitled to share in said savings unless the proposal is made in accordance with Paragraph I of this article. Except as provided in Paragraph I below, the Contractor will not be compensated for any direct, incidental or collateral benefits or savings the Owner receives as a result of the proposal.

I. Value Engineering Change Proposals: The Contractor may submit to the Architect/Engineer one or more cost reduction proposals for changing the Contract requirements. The proposals shall be based upon a sound study made by the Contractor indicating that the proposal:

- a. Will result in a net reduction in the total Contract amount;
- b. Will not impair any essential function or characteristic of the Work such as safety, service life, reliability, economy of operation, ease of maintenance and necessary standardized features;
- c. Will not require an unacceptable extension of the Contract completion time; and

- d. Will require a change in the Contract Documents and such change is not already under consideration by the Owner.
 - i. The Owner may accept in whole or in part any proposal submitted pursuant to the previous paragraph on Value Engineering Change Proposals by issuing a Change Order which will identify the proposal on which it is based. The Change Order will provide for a Contract change in the Contract price and will revise any other affected provisions of the Contract Documents. The equitable adjustment in the Contract price will be established by determining the net savings resulting from the accepted change. The net savings resulting from the change will be shared between the Contractor and the Owner on the basis of 50 percent for the Contractor and 50 percent for the Owner and will be limited to one Value Engineering Change Proposal per Change Order. Net savings will be determined by deducting from the proposal's estimated gross savings (1) the Contractor's costs of developing and implementing the proposal (including any amount attributable to a subcontractor) and (2) the estimated amount of increased costs to the Owner resulting from the change, such as evaluation, implementation, inspection, related items, and Owner -furnished material. Estimated gross savings will include Contractor's labor, material, equipment, overhead, profit and bond. The Contract price will be reduced by the sum of the Owner's costs and share of the net savings. For the purposes of this article, the applicable provisions of the Contract Documents shall be used to determine the equitable adjustment to the Contract price.
 - ii. The Owner will not be liable for delay in acting upon, or for failure to act upon, any proposal submitted pursuant to of this article. The decision of the Owner as to the acceptance or rejection of any such proposal under the Contract will be final. The submission of a proposal by the Contractor will not in itself affect the rights or obligations of either party under the Contract.
 - iii. The Contractor shall have the right to withdraw part or all of any proposal he may make under Paragraph 2 of this article at any time prior to acceptance by the Owner. Such withdrawal shall be made in writing to the Architect/Engineer. Each such proposal shall remain valid for a period of 60 days from the date submitted. If the Contractor wishes to withdraw the proposal prior to the expiration of the 60 day period he will be liable for the cost incurred by the Owner in reviewing the proposal.

- iv. The Contractor shall specifically identify any proposals under Paragraph 2 of this article with the heading "Value Engineering Change Proposal", or the proposal will be considered as made under Paragraph 1 of this article.
- 2) The Contractor, in connection with each proposal for a Contract Change Notice under this article, shall furnish the following information:
 - a. A description of the difference between the existing Contract requirement and the proposed change, and the comparative advantages and disadvantages of each, justification when a function or characteristic of an item is being altered, and the effect of the change on the performance of the end item;
 - b. An analysis and itemization of the requirements of the Contract which must be changed if the Value Engineering Change Proposal is accepted and a recommendation as to how to make each such change (e.g., a suggested specification revision);
 - c. A separate detailed cost estimate for both the existing Contract requirement and the proposed change to provide an estimate of the reduction in costs, if any, that will result from acceptance of the Value Engineering Change Proposal taking into account the costs of development and implementation by the Contractor;
 - d. A prediction of any effects the proposed change would have on collateral costs to the Owner such as government-furnished property costs, costs of related items, and costs of maintenance and operation;
 - e. A statement of the time by which a Contract modification accepting the Value Engineering Change Proposal must be issued so as to obtain the maximum cost reduction, noting any effect on the Contract completion time or delivery schedule; and
 - f. Identification of any previous submission of the Value Engineering Change Proposal to the Owner, including the dates submitted, the numbers of the contracts involved, and the previous actions by the Owner.
- 3) The Contractor waives any and all claims relating to any delay that may arise out of a Value Engineering Change Proposal.

END OF ARTICLE

11. CLAIMS AND DISPUTES

(June 12, 2012)

A. Notice of Claims

- 1) The Contractor will not be entitled to additional time or compensation otherwise payable for any act or failure to act by the Owner, the happening of any event or occurrence, or any other cause, unless he shall have given the Architect/Engineer a written notice of claim therefore as specified in this article.
- 2) The Contractor shall provide immediate verbal notification with written confirmation within forty-eight (48) hours of any potential claims and of the anticipated time and/or cost impacts resulting thereof. The written notice of claim shall set forth the reasons for which the Contractor believes additional compensation and/or time will or may be due, the nature of the costs involved and the approximate amount of the potential claim.
- 3) It is the intention of this article, that differences between the parties arising under and by virtue of the Contract shall be brought to the attention of the Architect/Engineer at the earliest possible time in order that such matters may be settled, if possible, or other appropriate action promptly taken.
- 4) The notice requirements of this article are in addition to those required in other articles of these Contract Documents.
- 5) The Contractor shall segregate all costs associated with each individual claim including but not limited to labor, equipment, material, subcontractor and supplier costs, and all other costs related to the claim. In the event that the Contractor has multiple claims, the Contractor will segregate each claim individually including the respective costs associated with each claim. Failure to segregate claims and their respective costs will be grounds for the Owner's rejection of the claim. No "total cost claims" shall be allowed under this Contract.
- 6) The Contractor must maintain a cost accounting system as a condition for making a claim against the Owner. The cost accounting system must segregate the costs of the work under the Contract (non-claims-related) from claims-related and other Contractor costs through the use of a job cost ledger and be otherwise in compliance with general accounting principles.
- 7) If the Owner decides to pay all or part of a claim for which notice was not timely made, the Owner does not waive the right to enforce the notice requirements in connection with any other claim.
- 8) Inasmuch as the notice of claim requirements of this article are intended to enable the Architect/Engineer to investigate while facts are fresh and to take action to minimize or avoid a claim which might be filed thereafter, the Contractor's failure to make the required notice on time is likely to disadvantage the Owner. Therefore, a claim that does not comply with the

notice requirements above shall not be considered unless the Contractor submits with his claim proof showing that the Owner has not been prejudiced by the Contractor's failure to so comply and, in the event the Owner has been prejudiced by the Contractor's failure to submit a timely notice of claim, the Owner will reduce any equitable adjustment claimed by the Contractor to reflect the damage.

B. Claim Submittals

- 1) Claims or requests for equitable adjustments filed by the Contractor shall be filed in full accordance with this article no later than 30 calendar days after the act giving rise to the claim and in sufficient detail to enable the Owner to ascertain the basis and amount of said claims. In the case of continuing or ongoing claim events, the Contractor shall be allowed to periodically amend his claim to more accurately reflect the impact of said claim, until the end of the claim event. No claims for additional compensation, time extension or for any other relief under the Contract shall be recognized, processed, or treated in any manner unless the same is presented in accordance with this Article. Failure to present and process any claim in accordance with this Article shall be conclusively deemed a waiver, abandonment or relinquishment of any such claim, it being expressly understood and agreed that the timely presentation of claims, in sufficient detail to allow proper investigation and prompt resolution thereof, is essential to the administration of this Contract.
- 2) The Owner will review and evaluate the Contractor's claims. It will be the responsibility of the Contractor to furnish, when requested by the Architect/Engineer, such further information and details as may be required to determine the facts or contentions involved in his claims. The cost of claims preparation or Change Order negotiations shall not be reimbursable under this Contract.
- 3) Any work performed by the Contractor prior to Notice-to-Proceed (NTP) shall not be the basis for a claim from the Contractor of any kind.
- 4) Each claim must be certified by the Contractor as required by the Miami-Dade Code, False Claims Act (see Code Section 21-255, et seq.), and accompanied by all materials required by Miami-Dade County Code Section 21-257. A "certified claim" shall be made under oath by a person duly authorized by the claimant, and shall contain a statement that:
 - a. The claim is made in good faith;
 - b. The claim's supporting data is accurate and complete to the best of the person's knowledge and belief;
 - c. The amount of the claim accurately reflects the amount that the claimant believes is due from the Owner; and
 - d. The certifying person is duly authorized by the claimant to certify the claim.

- 5) In order to substantiate time-related claims (delays, disruptions, impacts, etc.), the Contractor shall, if applicable and as determined by the Owner, submit, in triplicate, the following information:
- a. Copy of Contractor's notice of claim in accordance with this article. Failure to submit the notice is sufficient grounds to deny the claim.
 - b. The approved, as-planned Schedule in accordance with the applicable section of the Contract Documents and computer storage media, if applicable.
 - c. The as-built Schedule reflecting changes to the approved schedule up to the time of the impact in question and computer storage media if applicable.
 - d. The basis for the duration of the start and finish dates of each impact activity and the reason for choosing the successor and predecessor events affected in the schedule shall be explained. Also, the basis for the duration of any lead/lags inserted into the schedule and the duration in related activity duration shall be explained.
 - e. A marked-up as-built Schedule indicating the causes responsible for changes between the as-planned and as-built schedule and establishing the required cause and effect relationships.
 - f. After indicating specific time related changes on the as-built schedule, the documentation must be segregated into separate packages with each package documenting a specific duration change identified previously. This documentation package shall include Change Orders, Change Notices, Work Orders, written directions, meeting minutes, etc., related to the change in duration.
 - g. Any loss of efficiency, acceleration, disruption and loss of productivity claims shall be compensated as part of the Liquidated Indirect Costs paid for compensable, excusable delays and mark-up on Direct Cost of changes as allowed by the Contract. Total cost and modified total cost claims will not be accepted and the Contractor agrees to waive the right to seek recovery by these methods. The claimed delay shall not result from a cause specified in the Contract Documents as a non-excusable delay.
 - h. The Contractor assumes all risk for the following items, none of which shall be the subject of any claim and none of which shall be compensated for except as they may have been included in the compensation described under Liquidated Indirect Costs: (1) home office expenses or any Direct Costs incurred allocated from the headquarters of the Contractor; (2) loss of anticipated profits on this or any other project, (3) loss of bonding capacity or capability; (4) losses due to other projects not bid upon; (5) loss of business opportunities; (6) loss of productivity on this or any other project; (7) loss of interest income on funds not paid; (8) costs to prepare,

negotiate or prosecute claims and (9) costs spent to achieve compliance with applicable laws and ordinances (excepting only sales taxes paid shall be reimbursable expense subject to the provisions of the Contract Documents).

- i. All non-time-related claim items for additional compensation for Direct Costs shall be properly documented and supported with copies of invoices, time sheets, rental agreements, crew sheets and the like.
 - j. Cost information shall be submitted in sufficient detail to allow for review. The basis for the budgeted or actual costs shall include man-hours by trade, labor rates, material and equipment costs etc. These costs shall be broken down by pay item and Construction Specification Institute (CSI) Division.
 - k. The documentation for budgeted cost shall, as a minimum, include:
 - i. Copies of all the Contractor's bid documents, bid quotes, faxed quotes, etc.
 - ii. Copies of all executed subcontracts.
 - iii. Other related budget documents as requested by the Architect/Engineer.
 - l. The documentation for actual cost shall, as a minimum, include:
 - i. Time Sheets.
 - ii. Materials invoices
 - iii. Equipment invoices
 - iv. Subcontractors' payments
 - v. Other related documents as required by the Architect/Engineer.
 - m. The Contractor shall make all his books, employees, work sites and records available to the Owner or its representatives for inspection and audit.
 - n. No payment shall be made to the Contractor by the Owner for loss of anticipated profit(s) from any deleted work.
- 6) As indicated above, the Architect/Engineer and the Field Representative shall be allowed full and complete access to all personnel, documents, work sites or other information reasonably necessary to investigate any claim. Within sixty (60) days after a claim has been received, the claim shall either be rejected with an explanation as to why it was rejected or acknowledged. Once the claim is acknowledged, the parties shall attempt to negotiate a satisfactory settlement of the claim, which settlement shall be included in a subsequent Work Order or Change Order. If the parties fail to reach an agreement on a recognized claim, the Owner shall pay to the Contractor the amount of money it deems

reasonable, less any appropriate retention, to compensate the Contractor for the recognized claim.

- 7) Failure of the Contractor to make a specific reservation of rights regarding any such disputed amounts in the body of the Change Order which contains the payment shall be construed as a waiver, abandonment, or relinquishment of all claims for additional monies resulting from the claims embodied in said Change Order. However, once the Contractor has properly reserved rights to any claim, no further reservations of rights shall be required and the Contractor shall not be required to repeat the reservation in any subsequent change order. Prior reservation of rights may however be modified, by express reference, in subsequent change orders. Notwithstanding the aforementioned, at the time of final payment under the Contract, the Contractor shall specify all claims which have been denied and all claims for which rights have been reserved in accordance with this section. Failure to so specify any particular claim shall be constructed as a waiver, abandonment, or relinquishment of such claim.

C. Disputes

- 1) The following provisions shall govern disputes under this Contract unless the Special Provisions to this Contract contain the requirement for the use of an alternate dispute resolution method. For example, for large projects of great complexity, a Dispute Review Board (DRB) may be employed by the Owner to settle disputes in lieu of the Department Director or OOM designee as specified below. In this case, the DRB alternative shall be specified by the individual department in the Special Provisions and, if utilized, shall supersede this dispute provision.
 - a. In the event the Contractor and Owner are unable to resolve their differences concerning any determination made by the Architect/Engineer or Owner on any dispute or claim arising under or relating to the Contract (referred to in this Section as a "Dispute"), either the Contractor or Owner may initiate a dispute in accordance with the procedure set forth in this article. Exhaustion of these procedures shall be a precondition to any lawsuit permitted hereunder.
 - b. For contracts with a value of \$5 million or less, all Disputes under this Contract shall be decided by the Department Director or his designee. For contracts valued at more than \$5 million, Disputes shall be decided by a designee appointed by the Office of the Mayor (OOM). Decisions rendered by the Department Director or OOM designee shall not be binding but shall be admissible in a court of competent jurisdiction.
 - c. As soon as practicable, the Department Director or OOM designee shall adopt a schedule for the Contractor and Owner to file written submissions stating their respective positions and the bases therefore. The written submissions shall include copies of all documents and sworn statements in affidavit form from all witnesses relied on by each party in support of its position. Within 20 working days of the date on which such written submissions are filed, the Department Director or OOM designee shall

afford each party an opportunity to present a maximum of one hour of argument. The Department Director or OOM designee may decide the Dispute on the basis of the affidavits and other written submissions if, in his opinion, there is no issue of material fact and the party is entitled to a favorable resolution pursuant to the terms of this Contract. As part of such decision, the Department Director or OOM designee shall determine the timeliness and sufficiency of each notice of claim and claim at issue as provided in this article. The Department Director or OOM designee shall have the authority to rule on questions of law, including disputes over contract interpretation, and to resolve claims, or portions of claims, via summary judgment where there are no disputed issues of material fact. Furthermore, the Department Director or OOM designee is authorized by both parties to strike elements of claims seeking relief or damages not available under the contract (such as, but not limited to, claims for lost profits, off-site overhead, loss of efficiency or productivity claims or claim's preparation costs) by summary disposition.

- d. In the event that the Department Director or OOM designee determines that the affidavits or other written submissions present issues of material fact, he shall allow the presentation of evidence in the form of lay or expert testimony directed solely to the issues which he may specifically identify to require factual resolution. The testimonial portion of the process shall not exceed one day in duration per side, including opening statements and closing arguments, if allowed by the Department Director or OOM designee at his reasonable discretion.
- e. No formal discovery shall be allowed in connection with any proceeding under this article. Notwithstanding the foregoing, both parties agree that all of the audit, document inspection, information and documentation requirements set forth elsewhere in this contract shall remain in force and effect throughout the proceeding. The Department Director or OOM designee shall not schedule the hearing until both parties have made all their respective records available for inspection and reproduction and the parties have been afforded reasonable time to analyze the records. The continued failure of a party to comply with the document inspection, examination, or submission requirements set forth in this contract shall constitute a waiver of that party's claims and/or defenses, as applicable. Hearsay evidence shall be admissible but shall not form the sole basis for any finding of fact. Failure of any party to participate on a timely basis, to cooperate in the proceedings, or to furnish evidence in support or defense of a claim shall be a criteria in determining the sufficiency and validity of a claim.
- f. The Department Director or OOM designee shall issue a written decision within 15 working days after conclusion of any testimonial proceeding and, if no testimonial proceeding is conducted, within 45 days of the filing of the last written submission. This written decision shall set forth the reasons for the disposition of the claim and a breakdown of any specific issues or

subcontractor claims. As indicated previously, the decision of the Department Director or OOM designee is not binding on the parties, but will be admissible in a court of competent jurisdiction.

- g. If either party wishes to protest the decision of the Department Director or OOM designee, such party may commence an action in a court of competent jurisdiction, within the periods prescribed by law, it being understood that the review of the court shall be limited to the question of whether or not the Department Director or OOM designee's determination was arbitrary and capricious, unsupported by any competent evidence, or so grossly erroneous to evidence bad faith.
- h. Pending final decision of a dispute hereunder, the Contractor shall proceed diligently with the performance of the Contract and in accordance with the Architect/Engineer's interpretation. Any presentation or request by the Contractor under this article will be subject to the same requirements for Submittal of Claims in this article.

D. Terminations

1) Termination for Convenience

- a. The Owner may at its option and discretion terminate the Contract, in whole or, from time to time in part, at any time without any default on the part of the Contractor by issuing a written Notice of Termination to the Contractor and its Surety, specifying the extent to which performance of work under the Contract is terminated and the date upon which such termination becomes effective, at least ten (10) days prior to the effective date of such termination.
- b. In the event of Termination for Convenience, the Owner shall pay the Contractor for all labor performed, all materials and equipment furnished by the Contractor and its Subcontractors, materialmen and suppliers and manufacturers of equipment less all partial payments made on account prior to the date of cancellation as determined by the Field Representative and approved by the Architect/Engineer. The Contractor will be paid for:
 - i. The value of all work completed under the Contract, based upon the approved Schedule of Values and/or Unit Prices,
 - ii. The value of all materials and equipment delivered to but not incorporated into the work and properly stored on the site,
 - iii. The value of all bonafide irrevocable orders for materials and equipment not delivered to the construction site as of the date of cancellation. Such materials and equipment must be delivered to the Owner to a site or location designated by the Department prior to release of payment for such materials and equipment.

- iv. The values calculated under i., ii. and iii. above shall be as determined by the Field Representative and approved by the Architect/Engineer.
- c. In the event of termination under this article, the Contractor shall not be entitled to any anticipated profits for any work not performed due to such termination.
- d. In the event of termination under this article, the Owner does not waive or void any credits otherwise due the Owner at the time of termination, including Liquidated Damages, and back charges for defective or deficient work.
- e. Upon termination as indicated above, the Field Representative shall prepare a certificate for Final Payment to the Contractor.

2) Termination for Default of Contractor

- a. The Contract may be terminated in whole or, from time to time in part, by the Owner for failure of the Contractor to comply with any requirements of the Contract Documents including but not limited to:
 - i. Failure to perform the work or failure to provide sufficient workers, equipment or materials to assure completion of work in accordance with the terms of the Contract, and the approved Schedule, or
 - ii. Failure to provide the Schedule for the Project by the date due, or
 - iii. Failure to provide adequate shop drawings by the dates indicated in the approved Schedule for the Project, or
 - iv. Failure to replace the superintendent in the time allotted, if required, or
 - v. Performing the work unsuitably or neglecting or refusing to remove materials or to perform anew such work as may be rejected as unacceptable and unsuitable, after written directions from the Field Representative, or
 - vi. Violating the terms of the Contract or performing work in bad faith, or
 - vii. Discontinuing the prosecution of the work, or
 - viii. Failure to resume work which has been discontinued within a reasonable time after notice to do so, or
 - ix. Abandonment of the Contract, or
 - x. Becomes insolvent or is declared bankrupt, or commits any act of bankruptcy or insolvency, or failure to maintain a qualifier, or

- xi. Allowing any final judgment to stand against him unsatisfied for a period of 10 days, or
 - xii. Making an assignment for the benefit of creditors, or
 - xiii. For any other cause whatsoever, fails to carry out the work in an acceptable manner or to comply with any other Contract requirement.
- b. Before the Contract is terminated, the Contractor and its Surety will be notified in writing by the Architect/Engineer or the Field Representative of the conditions which make termination of the Contract imminent. The Contract will be terminated by the Owner ten (10) days after said notice has been given to the Contractor and its Surety unless a satisfactory effort acceptable to the Owner has been made by the Contractor or its Surety to correct the conditions. If the Contractor fails to satisfactorily correct the conditions giving rise to the termination, the Owner may declare the Contract breached and send a written Notice of Termination to the Contractor and its Surety.
- c. The Owner reserves the right, in lieu of termination as set forth in this article, to withhold any payments of money which may be due or become due to the Contractor until the said default(s) have been remedied. In the event of Termination for Default, the Owner also reserves the right, in cases where the damages calculated by the Owner are expected to exceed the amount the Owner anticipated recovering from the Surety, to withhold amounts for work already performed.
- d. In the event the Owner exercises its right to terminate the Contract for default of the Contractor as set forth herein, the Owner shall have the option of finishing the work, through any means available to the Owner, or having the Surety complete the Contract in accordance with its terms and conditions. In case that the Owner decides to have the Surety take over the remaining performance of the Work, the time or delay between Notice of Default and start of work by the Surety is a non-excusable delay. If the Surety fails to act promptly, but no longer than thirty (30) calendar days after the Owner notifies the Surety of the Owner's decision to have the Surety complete the work, or after such takeover fails to prosecute the Work in an expeditious manner, the Owner may exercise any of its other options including completing the Work by whatever means and method it deems advisable. No claims for loss of anticipated profits or for any other reason in connection with the termination of the Contract shall be considered.
- e. Payments for the various Bid Items listed in the Bid Form will constitute full compensation for all expenses incurred in consequence of discontinuance of all or any portion of the Work except as provided in this section of the Contract Documents. In no event will compensation be made for anticipatory profits or consequential

damages as a result of a discontinuance of all or any portion of the Work.

- f. The Contractor shall immediately upon receipt communicate any Notice of Termination for Default issued by the Owner to the affected Subcontractors and suppliers at any tier.
- g. If, after Notice of Termination of the Contractor's right to proceed under the provisions of this article, it is determined for any reason that the Contractor was not in default under the provisions of this article, or that the Contractor was entitled to an extension of time under the Contract Documents, the rights and obligations of the parties shall be the same as if the Notice of Termination had been issued pursuant to the section of this article dealing with Termination for Convenience.

3) Termination for National Emergencies

- a. The Owner shall terminate the Contract or portion thereof by written notice when the Contractor is prevented from proceeding with the construction Contract as a direct result of an Executive Order of the President of the United States with respect to the prosecution of war or in the interest of national defense.
- b. When the Contract, or any portion thereof, is terminated before completion of all items of work in the Contract, payment will be made for the actual number of units or items of work completed at the Contract price or as mutually agreed for items of work partially completed or not started. No claims or loss of anticipated profits or for any other reason in connection with the termination of the Contract shall be considered.

4) Implementation of Termination

- a. If the Owner cancels or terminates the Contract or any portion thereof, the Contractor shall stop all work on the date and to the extent specified in the Notice of Termination and shall:
 - i. Cancel all orders and Subcontracts, to the extent that they relate to the performance of the work terminated and which may be terminated without costs;
 - ii. Cancel and settle other orders and Subcontracts, except as may be necessary for completion of such portion of the Work not terminated, where the cost of settlement will be less than costs which would be incurred were such orders and subcontracts to be completed, subject to prior approval of the Field Representative;
 - iii. Settle outstanding liabilities and claims arising out of such termination of orders and subcontracts, with the approval or ratification of the Owner, to the extent it may require, which

approval or ratification shall be final for the purposes of this Article;

- iv. Transfer title and deliver to the Owner, in the manner, at the time, and to the extent, if any, directed by it, in accordance with directions of the Field Representative, all fabricated or un-fabricated parts, all materials, supplies, work in progress, completed work, facilities, equipment, machinery or tools acquired by the Contractor in connection with the performance of the work and for which the Contractor has been or is to be paid;
- v. Assign to the Owner in the manner, at the times and to the extent directed by it, all of the right, title, and interest of the Contractor under the orders and subcontracts so terminated, in which case the Owner will have the right, at its discretion, to settle or pay any or all claims arising out of the termination of such orders and subcontracts;
- vi. Deliver to the Field Representative As-Built Documents, complete as of the date of cancellation or termination, plans, Shop Drawings, sketches, permits, certificates, warranties, guarantees, specifications, three (3) complete sets of maintenance manuals, pamphlets, charts, parts lists, spare parts (if any), operating instructions required for all installed or finished equipment or machinery, and all other data accumulated by the Contractor for use in the performance of the work.
- vii. Perform all work as may be necessary to preserve the work then in progress and to protect materials, plant and equipment on the site or in transit thereto. The Contractor shall also take such action as may be necessary, or as the Architect/Engineer may direct, for the protection and preservation of the property related to this Contract which is in the possession of the Contractor and in which the Owner has or may acquire an interest.
- viii. Complete performance of each part of the work not terminated by the Notice of Termination;
- ix. Use his best efforts to sell, in the manner, at the time, to the extent, and at the price or prices directed or authorized by the Owner, property of the types referred to above; provided, however, that the Contractor (a) shall not be required to extend credit to any purchaser, and (b) may acquire any such property under the conditions prescribed by and at a price or prices approved by the Owner; provided, further, that the proceeds of any such transfer or disposition will be applied in reduction of any payments to be made by the Owner to the

Contractor under this Contract or will otherwise be credited to the price or cost of the work covered by this Contract or paid in such other manner as the Owner may direct;

- x. Termination of the Contract or a portion thereof shall neither relieve the Contractor of its responsibilities for the completed work nor shall it relieve its Surety of its obligation for and concerning any just claim arising out of the work performed.
- xi. In arriving at the amount due the Contractor under this article, there will be deducted, (1) any claim which the Owner may have against the Contractor in connection with this Contract and (2) the agreed price for, or the proceeds of sale of materials, supplies or other items acquired by the Contractor or sold, pursuant to the provisions of this article, and not otherwise recovered by or credited to the Owner.

5) Suspension of Work

- a. The Owner reserves the right to temporarily suspend execution of the whole or any part of the Work without compensation to the Contractor.
- b. In case the Contractor is actually and necessarily delayed by any act or omission on the part of the Owner, as determined by the Owner in writing, the time for completion of the Work shall be extended by the amount of the time of such delay as determined by the Owner, and an allowance may be made for actual direct costs, if any, which may have been borne by the Contractor. Such requests for additional time and/or compensation must be made in accordance with the applicable sections of the Contract Documents.
- c. Only the actual delay necessarily resulting from the causes specified in this Article, shall be grounds for extension of time. In case the Contractor is delayed at any time or for any period by two or more of the causes specified in this Article, the Contractor shall not be entitled to a separate extension for each one of the causes but only one period of extension will be granted for the delay.
- d. In case the Contractor is actually and necessarily delayed in the performance of the Work from one or more of the causes specified in this Article, the extension of time to be granted to the Contractor shall be only for such portion of the Work so delayed. The Contractor shall not be entitled by reason of such delay to an extension of time for the completion of the remainder of the Work. If the Contractor shall be so delayed as to a portion of the Work he shall nevertheless proceed continuously and diligently with the prosecution of the remainder of the Work. No demand by the Contractor that the Owner determine and certify any matter of extension of time for the completion of the Work or any part thereof will be of any effect whatsoever unless the demand

be made in writing at least 30 days before the completion date of the Work or any part thereof for which Liquidated Damages are established when meeting those dates is claimed to have been delayed by a suspension under this Article. Owner's determination as to any matter of extension of time for completion of the Work or any part thereof shall be binding and conclusive upon the Contractor.

- e. Permitting the Contractor to finish the Work or any part thereof after the time fixed for completion or after the date to which the time for completion may have been extended or the making of payments to the Contractor after any such periods shall not operate as a waiver on the part of the Owner of any rights under this contract.
- f. The Contractor shall insert in each subcontract a provision that the Subcontractor shall comply immediately with a written order of the Owner to the Contractor to suspend the Work, and that they shall further insert the same provision in each subcontract of any tier.

END OF ARTICLE

12. MISCELLANEOUS PROVISIONS

(June 12, 2012)

A. Third Party Beneficiary

No contractual relationship will be recognized under the Contract other than the contractual relationship between the Owner and the Contractor. There shall be no third party beneficiary to this Contract.

B. Venue

Any litigation which may arise out of this Contract shall be commenced either in the Eleventh Judicial Circuit Court in and for Miami-Dade County, Florida, or in the United States District Court, Southern District of Florida.

C. Governing Laws

- 1) The Contractor shall, during the term of this Contract and in the prosecution of the work, be governed by the statutes, regulatory orders, ordinances and procedures of the United States of America, the State of Florida and Miami-Dade County including but not limited to the Florida Building Code and the provisions of the Code of Miami-Dade County governing Community Small Business Enterprises (CSBEs) as applicable.
- 2) Specifically, the Contractor and his Subcontractors shall comply with Miami-Dade County Resolution Nos. R-1386-09 and R-138-10 governing the treatment of CSBE firms.
- 3) In addition the Contractor agrees to abide by all federal, state, and County procedures, as may be amended from time to time, regarding how documents to which the Contractor has access are handled, copied, and distributed, particularly documents that contain sensitive security information.

D. Successors and Assigns

The Owner and the Contractor each bind themselves, their partners, successors, assigns and legal representatives to the other party hereto and to the partners, successors, assigns and legal representatives of such other party in respect to all covenants, agreements and obligations contained in the Contract Documents. The Contractor shall not assign the Contract or sublet it as a whole without the written consent of the Owner, nor shall the Contractor assign any moneys due or to become due the Contractor hereunder, without the previous written notice to the Owner. Consent will not be given to any proposed assignment which would relieve the Contractor or his Surety of their responsibilities under the Contract.

E. Written Notice

- 1) Written notice to the Contractor shall be deemed to have been duly served if delivered in person to the individual or member of the firm or to any officer of the corporation for whom it was intended or if delivered at or sent by registered or certified mail to the last business address known to those who give the notice.

- 2) Written notice to the Owner shall be deemed to have been duly served if delivered in person, delivered at or sent by registered or certified mail to the individual identified in the Special Provisions.

F. Indemnification

- 1) In consideration of this Agreement, and to the maximum extent permitted by Chapter 725, Florida Statutes, as may be amended, the Contractor agrees to indemnify, protect, defend, and hold harmless the Government, State, County, their elected officials, officers, employees, consultants, and agents from claims, liabilities, damages, losses, and costs including, but not limited to reasonable attorney's fees at both the trial and appellate levels to the extent caused by the negligence, recklessness, or intentionally wrongful conduct of the Contractor and other persons employed or utilized by the Contractor in the performance of the Work.
- 2) The indemnification obligation under this clause shall not be limited in any way by any limitation on the amount or type of damages, compensation, or benefits payable by or for the Contractor and/or any Subcontractor under worker's compensation acts, disability benefit acts, or other employee benefit acts.
- 3) In the event that any claims are brought or actions are filed against the Owner with respect to the indemnity contained herein, the Contractor agrees to defend against any such claims or actions regardless of whether such claims or actions are rightfully or wrongfully brought or filed. The Contractor agrees that the Owner may select the attorneys to appear and defend such claims or actions on behalf of the Owner. The Contractor further agrees to pay at the Contractor's expense the attorneys' fees and costs incurred by those attorneys selected by the Owner to appear and defend such claims or actions on behalf of the Owner. The Owner, at its sole option, shall have the sole authority for the direction of the defense, and shall be the sole judge of the acceptability of any compromise or settlement of any claims or actions against the Owner.
- 4) To the extent this indemnification clause or any other indemnification clause in this Agreement does not comply with Chapter 725, Florida Statutes, as may be amended, this provision and all aspects of the Contract Documents shall hereby be interpreted as the parties' intention for the indemnification clauses and Contract Documents to comply with Chapter 725, Florida Statutes, as may be amended.
- 5) This Section shall survive expiration or termination of this Agreement.

G. Audit Rights

- 1) Access to Records
 - a. The Contractor shall, during the term of this Contract and for a period of five years thereafter, allow the Owner and its duly authorized representatives to inspect all payroll records, invoices for materials, books of account, job cost ledgers, Project correspondence and Project-related files and all relevant records pertinent to the Contract.

- b. The Owner retains the right to audit accounts and access all files, correspondence and documents in reference to all work performed under this Contract. The Owner shall be provided full access upon request to all documents, including those in possession of Subcontractors or suppliers during the work and for a period of five years after the completion of the Work. In case of any litigation regarding this Project, such rights shall extend until final settlement of such litigation. Failure to allow the Owner access shall be deemed a waiver of Contractor's claims.
- c. The Contractor shall maintain a banking account within Miami-Dade County for all payments to laborers, Subcontractors and vendors furnishing labor and materials under this Contract. All records shall be maintained in Miami-Dade County for the term of this Contract.

2) Inspector General

- a. According to Section 2-1076 of the Code of Miami-Dade County, Miami-Dade County has established the Office of the Inspector General (IG) which may, on a random basis, perform audits, inspections, and reviews of all, on any County/Trust contracts, throughout the duration of said contracts. This random audit is separate and distinct from any other audit by the County. To pay for the functions of the Office of the Inspector General, any and all payments to be made to the Contractor under this contract will be assessed one quarter (1/4) of one (1) percent of the total amount of the payment, to be deducted from each progress payment as the same becomes due unless this Contract is federally or state funded where federal or state law or regulations preclude such a charge or where such a charge is otherwise precluded by Special Condition. The Contractor shall, in stating its agreed prices, be mindful of this assessment which will not be separately identified, calculated or adjusted in the proposal or Bid Form.
- b. The Miami-Dade Office of the Inspector General is authorized to investigate County affairs and empowered to review past, present and proposed County and Public Health Trust programs, accounts, records, contracts and transactions. In addition, the Inspector General has the power to subpoena witnesses, administer oaths, require the production of witnesses and monitor existing Projects and programs. Monitoring of an existing Project or program may include a report concerning whether the Project is on time, within budget and in conformance with the Contract Documents and applicable law. The Inspector General shall have the power to audit, investigate, monitor, oversee, inspect and review operations, activities, performance and procurement process including but not limited to Project design, bid specifications, (bid/proposal) submittals, activities of the (Contractor/ Vendor/ Consultant), its officers, agents and employees, lobbyists, County and Public Health Trust staff and

elected officials to ensure compliance with the Contract Documents and to detect fraud and corruption.

- c. Upon ten (10) days written notice to the Contractor, the Contractor shall make all requested records and documents available to the Inspector General for inspection and copying. The Inspector General is empowered to retain the services of independent private sector inspectors general to audit, investigate, monitor, oversee, inspect and review operations, activities, performance and procurement process including but not limited to Project design, bid specifications, (bid/proposal) submittals, activities of the (Contractor/ Vendor/ Consultant), its officers, agents and employees, lobbyists, County staff and elected officials to ensure compliance with the Contract Documents and to detect fraud and corruption.
- d. The Inspector General shall have the right to inspect and copy all documents and records in the (Contractor/Vendor/Consultant's) possession, custody or control which in the Inspector General's sole judgment, pertain to performance of the contract, including, but not limited to original estimate files, change order estimate files, worksheets, proposals and agreements from and with successful subcontractors and suppliers, all Project-related correspondence, memoranda, instructions, financial documents, construction documents, (bid/proposal) and contract documents, back-change documents, all documents and records which involve cash, trade or volume discounts, insurance proceeds, rebates, or dividends received, payroll and personnel records and supporting documentation for the aforesaid documents and records.
- e. The Contractor shall make available at its office at all reasonable times the records, materials, and other evidence regarding the acquisition (bid preparation) and performance of this contract, for examination, audit, or reproduction, until three (3) years after final payment under this contract or for any longer period required by statute or by other clauses of this contract. In addition:
 - i. If this contract is completely or partially terminated, the Contractor shall make available records relating to the work terminated until three (3) years after any resulting final termination settlement; and
 - ii. The Contractor shall make available records relating to appeals or to litigation or the settlement of claims arising under or relating to this contract until such appeals, litigation, or claims are finally resolved.
- f. The provisions in this section shall apply to the (Contractor/Vendor/Consultant), its officers, agents, employees, subcontractors and suppliers. The (Contractor/Vendor/Consultant) shall incorporate the provisions in this section in all subcontracts and

all other agreements executed by the (Contractor/Vendor/Consultant) in connection with the performance of this contract.

- g. Nothing in this section shall impair any independent right to the Owner to conduct audits or investigative activities. The provisions of this section are neither intended nor shall they be construed to impose any liability on the Owner by the (Contractor/Vendor/Consultant) or third parties.

H. Severability

- 1) In the event any article, section, sub-article, paragraph, sentence, clause or phrase contained in the Contract Documents shall be determined, declared or adjudged invalid, illegal, unconstitutional or otherwise unenforceable, such determination, declaration or adjudication shall in no manner affect the other articles, sections, sub-articles, paragraphs, sentences, clauses or phrases of the Contract Documents, which shall remain in full force and effect as if the article, section, sub-article, paragraph, sentence, clause or phrase declared, determined or adjudged invalid, illegal, unconstitutional or otherwise unenforceable was not originally contained in the Contract Documents.

I. Payment and Performance Bonds

- 1) The Contractor shall, as a condition of contract, provide to the County two separate bonds, one bonding payment and one bonding performance. Each bond shall be for no less than 100% of the total maximum contract amount. The payment bond and performance bond shall be in the forms requested under Sections 713.23 and 255.05, respectively, of the Florida Statutes. These bonds shall be in substantial compliance with the requirements of the forms attached hereto as _____.

- a. The bonds shall be written through surety insurers authorized to do business in the State of Florida as Surety, with the following qualifications as to management and financial strength according to the latest edition of Best's Insurance Guide, published by A.M. Best Company, Oldwick, New Jersey:

<u>Bond (Total Contract) Amount</u>	<u>Best's Rating</u>
\$500,001 to \$1,500,000.....	B V
\$1,500,001 to \$2,500,000.....	A VI
\$2,500,001 to \$5,000,000.....	A VII
\$5,000,000 to \$10,000,000.....	A VIII
Over \$10,000,000.....	A IX

- 2) On Contract amounts of \$500,000 or less, the Bond provisions of Section 287.0935, Florida Statutes shall be in effect and surety companies not otherwise qualifying with this paragraph may optionally qualify by:

- a. Providing evidence that the surety has twice the minimum surplus and capital required by the Florida Insurance Code at the time the Invitation to Bid is issued.
- b. Certifying that the surety is otherwise in compliance with the Florida Insurance Code, and
- c. Providing a copy of the currently valid Certificate of Authority issued by the United States Department of Treasury under 31 U.S.C. 9304-9308.

Surety insurers shall be listed in the latest Circular 570 of the U.S. Department of the Treasury entitled "Surety Companies Acceptable on Federal Bonds", published annually. The Bond amounts shall not exceed the underwriting limitations as shown in this circular.

- 3) For Contracts in excess of \$500,000 the provisions of the Contract Documents will be adhered to, plus the surety insurer must have been listed on the U.S. Treasury list for at least three consecutive years, or currently hold a valid Certificate of Authority of at least 1.5 million dollars and listed on the Treasury list.
- 4) Payment and Performance Bonds guaranteed through U.S. Government Small Business Administration or Contractors Training and Development Inc. will also be acceptable.
- 5) The attorney-in-fact or other officer who signs Payment and Performance Bonds for a surety company must file with such Bonds a certified copy of his/her power of attorney authorizing him/her to do so.
- 6) The cost of the Bonds shall be included in the Bid.
- 7) The required Bonds shall be written by or through and shall be countersigned by, a licensed Florida agent of the surety insurer, pursuant to Section 624.425 of the Florida Statutes.
- 8) The Bonds shall be delivered to the Contracting Officer in accordance with the instructions within the Notice of Award.
- 9) In the event the Surety on the Payment and Performance Bonds given by the Contractor becomes insolvent, or is placed in the hands of a receiver, or has its right to do business in its State of domicile or the State of Florida suspended or revoked as provided by law, the Owner shall withhold all payments under the provisions of these Contract Documents until the Contractor has given good and sufficient Bonds in lieu of Bonds executed by such Surety.
- 10) Cancellation of any Bonds, or non-payment by the Contractor of any premium for any Bonds required by this Contract, shall constitute a breach of this Contract. In addition to any other legal remedies, the Owner at its sole option may terminate this Contract or pay such premiums, and deduct the costs thereof from any amounts that are or may be due to the Contractor.

J. Insurance

The Contractor shall maintain the insurance set forth in the Special Provisions throughout the performance of this Contract until the Work has been completed by the Contractor and accepted by the Owner.

K. Conflict of Interest

- 1) The Contractor or his employees shall not enter into any Contract involving services or property with a person or business prohibited from transacting such business with Miami-Dade County pursuant to Section 2-11.1 of the Code of Miami-Dade County, Florida, known as the Miami-Dade County Conflict of Interest and Code of Ethics Ordinance.
- 2) In the event the Contractor, or any of its officers, partners, principals or employees are convicted of a crime arising out of, or in connection with, the work to be done or payment to be made under this Contract, this Contract, in whole or any part thereof may, at the discretion of the Owner, be terminated without prejudice to any other rights and remedies of the Owner under the law.
- 3) In accordance with the Code of Miami-Dade County, no officer or employee of Miami-Dade County during his tenure or for two years thereafter shall have any interest, direct or indirect, in this Contract or the proceeds thereof.

L. Rights in Shop Drawings

- 1) Shop Drawings submitted to the Architect/Engineer by the Contractor, pursuant to the Work, may be duplicated by the Owner and the Owner may use and disclose, in any manner and for any purpose Shop Drawings delivered under this Contract.
- 2) This paragraph shall be included in all subcontracts hereunder at all tiers.

M. Patent and Copyright

- 1) If the Contractor is required or desires to use any design, device, material, or process covered by letters of patent or copyright, he shall provide for such use by suitable legal agreement with the patentee or owner. The Contractor and the surety shall indemnify and save harmless the Owner, the Field Representative, and the Architect/Engineer from any and all claims for infringement by reason of the use of any such patented design, device, material or process, or any trademark or copyright, and shall indemnify the Owner for any costs, expenses, and damages which it may be obliged to pay by reason of an infringement, at any time during the prosecution or after the completion of the work.
- 2) The Contractor shall warrant that the materials, equipment or devices used on or incorporated in the Work shall be delivered free of any rightful claim of any third party for infringement of any United States patent or copyright. The Contractor shall defend, or may settle, at his expense, any suit or proceeding against the Owner or the Architect/Engineer so far as based on a claimed patent or copyright infringement which would result in a breach of this warranty, and the Contractor shall pay all damages and costs awarded therein against the Owner or the Architect/Engineer due to such breach. The Contractor shall

report to the Architect/Engineer, promptly and in reasonable written detail, each notice or claim of patent or copyright infringement based on the performance of this Contract of which the Contractor has knowledge. In the event of any claim or suit against the Owner on account of any alleged patent or copyright infringement arising out of the performance of this Contract or out of the use of any supplies furnished or work or services performed hereunder, the Contractor shall furnish to the Owner when requested, all evidence and information in possession of the Contractor pertaining to such suit or claim. Such evidence and information shall be furnished at the expense of the Contractor.

- 3) The Contractor shall bear all costs arising from the use of patented materials, equipment, devices or processes used on or incorporated in the Work. In such case materials, equipment, devices or processes are held to constitute an infringement and their use enjoined, the Contractor, at his expense shall:
 - a. Secure for the Owner the right to continue using said materials, equipment, devices or processes by suspension of the injunction or by procuring a license or licenses; or
 - b. Replace such materials, equipment, devices or processes with non-infringing materials, equipment, devices or processes; or
 - c. Modify them so that they become non-infringing or remove the enjoined materials, equipment, devices or processes and refund the sum paid therefore without prejudice to any other rights of the Owner.
- 4) The preceding paragraph shall not apply to any materials, equipment or devices, specified by the Owner or the Architect/Engineer or manufactured to the design of the Owner or the Architect/Engineer or in accordance with the details contained in the Contract Documents; and as to any such materials, equipment or devices the Contractor assumes no liability whatsoever for patent or copyright infringement and the Owner will hold the Contractor harmless against any infringement claims arising therefrom.
- 5) Patent rights to patentable invention, item or ideas of every kind or nature arising out of the Work, as well as information, designs, specifications, know-how, data and findings shall be made available to the Government for public use, unless the Owner shall, in specific cases where it is legally permissible, determine that it is in the public interest that it not be so made available.
- 6) The sense of this article shall be included in all subcontracts. The foregoing states the entire liability of the Contractor for patent or copy infringement by use of said materials, equipment or devices.

N. Historical, Scientific and Archaeological Discoveries

All articles of historical, scientific or archaeological interest uncovered by the Contractor during progress of the Work shall be preserved and reported immediately to the Architect/Engineer. Further operations of the Contractor with respect to the find, including disposition of the articles, will be decided by the Owner.

O. Use of Owner's Name in Contractor Advertising or Public Relations

The Owner reserves the right to review and approve Owner-related copy prior to publication. The Contractor shall not allow Owner-related copy to be published in Contractor's advertisement or public relations programs until submitting the Owner-related copy and receiving prior approval from the Owner. The Contractor shall agree that published information on the Owner or the Owner's program shall be factual and in no way imply that the Owner endorses the Contractor's firm, service or product. The Contractor shall insert the substance of this provision, including this sentence, in each subcontract and supply Contract or purchase order.

END OF ARTICLE

13. ATTACHMENTS

(June 12, 2012)

END OF ARTICLE

DEPARTMENT OF TRANSPORTATION AND PUBLIC WORKS

BID DOCUMENTS

KITCHEN REMODELING IN THE BREAKROOM OF PALMETTO METRORAIL STATION

RPQ NO. 14679

STANDARD GENERAL CONTRACT CONDITIONS

ATTACHMENT “ A “

Certificate of Acceptance for Substantial Completion

Certificate of Final Acceptance

CERTIFICATE OF ACCEPTANCE FOR SUBSTANTIAL COMPLETION

RPQ No.: _____

Date : _____

Description : _____

Address : _____

Contractor : _____

Consultant : _____

Surety : _____

*The work performed under the subject Contract has been reviewed, and subject to the Contract requirements of **Article 29, Substantial Completion, Final Inspection and Acceptance**, all remaining work has been found to be Substantially Completed as of _____.*

*A **Punch List** of items to be completed or corrected, is appended hereto.*

*In the event that the Work, including the Punch List items, is not corrected by the Contract Completion date, the Contract stipulations regarding **Liquidated Damages** will be imposed until such time as the work is certified by the County's Resident Engineer or its Consultant and the Director, MDT to be complete in all respects and a **Certificate of Final Acceptance** is issued.*

(COMPANY SEAL)

Signed : _____

Contractor

Recommended : _____

Resident Engineer/Project Manager

Recommended : _____

Chief, Construction

Certificate of Final Acceptance

RPQ No.:

Description:

Address:

Contractor:

Consultant:

Surety:

The **UNDERSIGNED** hereby certify that, to the best of our knowledge and belief, based on observations of the punch list work required under the terms of the Agreement, we have found that the Work items identified in the **PUNCH LIST**, dated _____ (“**PUNCH LIST**”) were completed as of _____. We therefore recommend that the **FINAL ACCEPTANCE DATE** be established as: _____

Notwithstanding the above, this Certificate shall not be construed as a finding regarding whether work performed on this Contract was done in accordance with all applicable Contract requirements, and the County expressly reserves all of its rights and claims under the Contract, or otherwise, to seek recovery or indemnity for any defects in materials, equipment, or workmanship, or for non-conformance with any Contract requirements.

Recommended : _____

Resident Engineer/Project Manager

Recommended : _____

Chief, Construction

:

DEPARTMENT OF TRANSPORTATION AND PUBLIC WORKS

BID DOCUMENTS

KITCHEN REMODELING IN THE BREAKROOM OF PALMETTO METRORAIL STATION

RPQ NO. 14679

STANDARD GENERAL CONTRACT CONDITIONS

ATTACHMENT “ B “

Contractor Release

Agreement on Final Quantities and Amounts

Final Affidavit

Labor Standards Provisions Final Certificate

Memorandum of Understanding

Certificate of Sub-Contractor Status

Final Release of Lien

DEPARTMENT OF TRANSPORTATION AND PUBLIC WORKS

CONTRACTOR RELEASE

RPO No.:

KNOW ALL MEN BY THESE PRESENTS : Pursuant to the terms of the Contract and in consideration of the sum of _____ paid by the *Miami-Dade County* under the Contract, the undersigned Contractor does, and by the receipt of said sum shall, for itself, its successors and assigns, remise, release and forever discharge MDC, its officers , agents and employees, of and from all liabilities, obligations, and claims whatsoever, in law and in equity, under or arising out of said Contract.

IN WITNESS WHEREOF, this release has been executed this _____ day of _____, 20____

(*COMPANY SEAL*)

Contractor

Signature

WITNESS :

Print Name : _____

Print Title : _____

NOTE : In the case of a corporation, witnesses are not required , but the ***CERTIFICATE*** below must be completed.

CERTIFICATE

I, _____, certify that I am the *Secretary* of the corporation named as Contractor in the foregoing release; that _____ who signed said release on behalf of the Contractor, was then _____ of said Corporation; that said release was duly signed for and on behalf of said corporation under the authority of its governing body, and within the scope of its corporate powers.

(*CORPORATE SEAL*)

Signature

DEPARTMENT OF TRANSPORTATION AND PUBLIC WORKS

AGREEMENT

ON

FINAL QUANTITIES AND AMOUNTS

RPO No.:

The Contractor and Resident Engineer agree that the **QUANTITIES** as shown on the **FINAL PAY REQUEST No.** are **EQUITABLY** paid for by application of the agreed **LUMP SUM PRICES**.

It is finally agreed that the right in the Contract clause to request negotiation of a different amount is **WAIVED** by the Contractor and the Authorized Representative of the Contracting Officer.

(*Company Seal*)

Contractor

Signature

Print Name

Print Title

Date

Resident Engineer

Print Name

Date

DEPARTMENT OF TRANSPORTATION AND PUBLIC WORKS

FINAL AFFIDAVIT

RPQ No.:

The undersigned Contractor, _____, certifies and warrants to ***Department of Transportation and Public Works*** that _____ has paid in full and completely discharged any and all claims, demands, obligations and liabilities of _____ in connection with or arising out of ***RPQ No.*** _____, including without limitation, all claims for labor performed and materials, supplies, equipment and other items furnished or used in connection with performance of said Contract.

(***COMPANY SEAL***)

Contractor : _____

Signature : _____

Print Name : _____

Print Title : _____

Date : _____

DEPARTMENT OF TRANSPORTATION AND PUBLIC WORKS

LABOR STANDARDS PROVISIONS

FINAL CERTIFICATE

RPO No.:

The undersigned Contractor, _____, hereby certifies that all laborers, mechanics, apprentices and trainees employed by him or by any Subcontractor performing work under the Contract on the project have been paid *wages at rates no less than those required by the Contract provisions*, and that the work performed by each laborer, mechanic, apprentice or trainee conformed to the classifications set forth in the Contract or training program provisions applicable to the wage rate paid.

EXCEPTION (S) :

Contractor : _____

(***COMPANY SEAL***)

Signature : _____

Print Name : _____

Print Title : _____

Date : _____

DEPARTMENT OF TRANSPORTATION AND PUBLIC WORKS

MEMORANDUM OF UNDERSTANDING

RPQ No.:

WHEREAS, _____, (hereafter referred to as the " Contractor ") and the *Miami-Dade Transit*, the parties hereto, have mutually agreed to the **total Contract amount** in the sum of _____ and a final payment of _____ for a **COMPLETE CLOSE-OUT** of *RPQ No.*

It is understood and expressly agreed that :

- (1) This Memorandum of Understanding is subject to the recommendations of the Assistant Director and the Director of Miami-Dade Transit.
- (2) In consideration of the payment by MDT of a **total Contract amount** of _____, (inclusive of all finalized Change Orders), the Contractor hereby withdraws with prejudice all Claims, Disputes, and Appeals of the Contractor or any of its Subcontractors or Suppliers under the subject Contract. MDT likewise, withdraws with prejudice, all Claims and/or Backcharges it has against the Contractor.
- (3) The retention withheld in *Pay Request No.* _____ is _____ and will be paid in full. Therefore, the Contractor acknowledges the final payment of _____ in *Pay Request No.* _____ as the outstanding balance due to date on the Contract.
- (4) MDT reserves the right to complete an audit upon the request of the Assistant Director, Engineering Services when warranted.
- (5) All terms and conditions of the Contract otherwise remain unchanged including the Contractor's liabilities for warranties, latent defects and the like.
- (6) The execution of this Memorandum and payment in accordance with these terms, and the finalized Contract Change Orders, shall constitute a full accord and satisfaction of all Claims and all rights of the parties against each other, except for claims of the Owner for latent defects discussed after the date of this Memorandum or for warranty items.

(COMPANY SEAL)

Contractor : _____

Signature : _____

Print Name : _____

Print Title : _____

Date : _____

RECOMMENDED

By : _____

Resident Engineer/Project Manager

By : _____

Chief, Construction Division

DEPARTMENT OF TRANSPORTATION AND PUBLIC WORKS

CERTIFICATE OF SUB-CONTRACTOR STATUS

This is to certify that the following is a complete list of sub-contractors who worked on

RPO No.:

Name	Description of work	Original Contract Amount	Paid to date	Amount Owed

(COMPANY SEAL)

Contractor

Signature

Print Name & Title

Date

ALL SUBCONTRACTORS WORKING ON THIS PROJECT MUST COMPLETE THIS FORM.

FINAL RELEASE OF LIEN

KNOW ALL PERSONS BY THESE PRESENTS:

That the undersigned, for and in consideration of the payment of the sum of _____ and _____ /100 dollars (\$_____) paid by the _____ receipt of which is hereby acknowledged, hereby releases and quit claims to the said _____ it successors and assigns, and _____ the owner, all liens, lien rights, claims or demands of any kind whatsoever, which the undersigned now has or might have against the building or premises legally _____ described _____ as _____ on _____ account of labor performed and/or material furnished for the construction of any improvements thereon. That all labor and materials used by the undersigned in the erection of said improvements have been fully paid for.

IN WITNESS THEREOF, I have hereunto set my hand seal this _____ day of _____, 20_____.

WITNESSES:

_____ (SEAL)

By _____

State of _____)
) ss

County of _____)

The foregoing instrument was acknowledged before me this _____ day of _____, 20_____ by _____ on behalf of _____ [] who is personally known to me or [] who has produced _____ as identification and who [] did [] did not take an oath.

Notary Signature: _____

Notary Seal:



Type or Print Name: _____

DEPARTMENT OF TRANSPORTATION AND PUBLIC WORKS

BID DOCUMENTS

KITCHEN REMODELING IN THE BREAKROOM OF PALMETTO METRORAIL STATION

RPQ NO. 14679

STANDARD GENERAL CONTRACT CONDITIONS

ATTACHMENT "C"

Sub-Contractor's/Supplier's Release of Claim

Consent of Surety Company to Requisition Payment

MIAMI-DADE COUNTY
DEPARTMENT OF TRANSPORTATION AND PUBLIC WORKS
SUBCONTRACTOR'S / SUPPLIER'S RELEASE OF CLAIM

NOTE: The General Contractor shall attach this statement, completed by each Subcontractor whose work appears on the prior requisition for payment or has work in place since the last requisition for payment.

Project No.: _____ Date: _____

Project Title: _____

Subcontractor:

Requisition No.: _____ From: _____ To: _____

Before me, the undersigned authority, authorized to administer oaths and take acknowledgments appeared: _____ who, after being first duly sworn, upon oath, deposes and says that pursuant to the provisions of his contract for said project, all money due him under prior requisitions for payment have been paid to him by _____, the General Contractor.

(COMPANY SEAL)

Legal Name of Subcontractor

Title

Signature

State of _____)

) ss

County of _____)

The foregoing instrument was acknowledged before me this _____ day of _____, 20____ by _____ on behalf of _____.

[] who is personally known to me or [] who has produced _____ as identification and who [] did [] did not take an oath.

Notary Signature: _____

Type or Print Name: _____

Notary Seal:

PROJECT RPQ No.: 14679



CONSENT OF SURETY COMPANY TO REQUISITION PAYMENT



PROJECT No. _____

PROJECT TITLE: _____

PROJECT LOCATION: _____

TO: _____ Re: PAY REQUEST No. _____ DATE: _____

IN THE AMOUNT OF: _____

CONTRACTOR: _____ RPQ No. _____

THE UNDERSIGNED SURETY COMPANY _____,

(INSERT NAME OF SURETY COMPANY)

_____, ON BOND OF

(ADDRESS)

THE CONTRACTOR LISTED ABOVE, HEREBY APPROVES THIS PAYMENT TO THE CONTRACTOR AND AGREES THAT THE PAYMENT TO THE CONTRACTOR SHALL NOT RELIEVE THE SURETY COMPANY OF ANY OF ITS OBLIGATIONS TO MIAMI-DADE COUNTY, INCLUDING THE SECURITY FROM ANY AND ALL LIENS, CLAIMS OR DEMANDS WHATSOEVER THAT MAY NOW EXIST OR BE MADE IN THE FUTURE BY ANY SUB-CONTRACTOR OR MATERIAL SUPPLIERS AGAINST THIS PROJECT AND CONTRACT.

THIS CONSENT OF SURETY RECOGNIZES THAT CLAIMS HAVE BEEN MADE BY THE FOLLOWING SUB-CONTRACTORS AND MATERIAL SUPPLIERS AGAINST THE CONTRACT IN THE AMOUNTS LISTED BELOW:

_____	\$ _____
_____	\$ _____
_____	\$ _____
_____	\$ _____
_____	\$ _____
_____	\$ _____
_____	\$ _____
_____	\$ _____

SURETY RECOGNIZES THAT RELEASES OF LIEN OR RELEASES AND ASSIGNMENT OF CLAIM HAVE NOT BEEN REQUESTED OR RECEIVED FROM ALL THE SUB-CONTRACTORS AND MATERIAL SUPPLIERS FOR THIS FACILITY.

IN WITNESS THEREOF,

THE SURETY COMPANY HAS HEREUNTO SET ITS HAND THIS _____ DAY OF _____, 20____.

DEPARTMENT OF TRANSPORTATION AND PUBLIC WORKS

BID DOCUMENTS

KITCHEN REMODELING IN THE BREAKROOM OF PALMETTO METRORAIL STATION

RPQ NO. 14679

STANDARD GENERAL CONTRACT CONDITIONS

ATTACHMENT "D"

"Contractor Agent to Accept Service"



DEPARTMENT OF TRANSPORTATION AND PUBLIC WORKS

CONTRACTOR AGENT TO ACCEPT SERVICE

RPQ No.: _____

DATE: _____

CONTRACT TITLE: _____

CONTRACTOR: _____

NOTICE TO PROCEED (NTP) DATE: _____

CONTRACTOR ADDRESS: _____

CONTRACTOR TELEPHONE No.: _____

AGENT'S NAME: _____

AGENT'S TITLE: _____

AGENT'S ADDRESS: _____

AGENT'S TELEPHONE No. _____

Contractor Corporate Representative

Submitted By: _____

SIGNATURE

DEPARTMENT OF TRANSPORTATION AND PUBLIC WORKS

BID DOCUMENTS

KITCHEN REMODELING IN THE BREAKROOM OF PALMETTO METRORAIL STATION

RPQ NO. 14679

STANDARD GENERAL CONTRACT CONDITIONS

ATTACHMENT "E"

Force Account Daily Report:
Labor, Material & Equipment

FORCE ACCOUNT DAILY REPORT:

DATE: _____



CONTRACTOR: _____

CONTRACT No. _____ REPORT No. _____

CONTRACT CHANGE NOTICE / MDT LETTER: _____ PAGE No. _____ of _____

IMPORTANT-THIS FORM MUST BE SIGNED AND SUBMITTED NOT LATER THAN THE DAY FOLLOWING DATE WORK WAS PERFORMED.

The following work was performed this date requiring the use of the Labor Force, Materials, Equipment, Special Forces and Services listed hereon:

Description of work performed:

LABOR					EQUIPMENT					
NAME	CRAFT	HRRAT	HOURS	TOTALS	MAKE	MODEL	DESCRIPTION	HOURS	RATE	EXT.

CERTIFIED CORRECT BY: _____	DATE _____
MATERIAL INVOICE ON UNIT PRICES TO BE PROVIDED.	

QUAN.	UNIT	DESCRIPTION	MATERIALS	RECAP
				LABOR
				MATERIALS
				EQUIPMENT

CERTIFIED CORRECT BY: _____	DATE _____	TOTAL THIS SHEET _____
<div style="border: 1px solid black; display: inline-block; padding: 2px;">FOR ENGINEER'S USE</div> APPROVED AS TO SUBSTANCE		EXTENSION OF LABOR, MATERIAL & EQUIPMENT VERIFIED BY:
BY: _____	DATE _____	INSPECTOR _____ DATE _____
RESIDENT ENGINEER		

DEPARTMENT OF TRANSPORTATION AND PUBLIC WORKS
BID DOCUMENTS

KITCHEN REMODELING IN THE BREAKROOM OF PALMETTO METRORAIL STATION

RPQ NO. 14679

TECHNICAL SPECIFICATIONS

DIVISION 01

SECTION

01 11 00	Summary of Work
01 32 16	Project Schedule
01 43 00	Quality Assurance Requirements
01 62 00	Substitutions and Product Options
01 78 36	Warranties

01 11 00 - Summary of Work

KITCHEN REMODELING IN THE BREAKROOM OF PALMETTO METRORAIL STATION

Scope of Work: (Contractor must obtain and submit all permits prior to performing any work.)

1.0 - SCOPE: The project involves demolishing an existing 88 inches long kitchen with upper and lower cabinets. It consists of purchasing and installing a new sink, two-handle water faucet, electric water heater, and cabinets above and below to cover a length of approximately 88 inches. They are outdoor cabinets from the WEATHER STRONG brand from Home Depot. The project includes the installation of a new dedicated microwave oven electrical outlet and a dedicated water cooler electrical outlet. New plumbing for a sink, water cooler, and electric water heater installation. The project also includes the demolition of 156 sq ft of flooring and the installation of new VCT flooring and a vinyl baseboard 6 inches high. During the breakroom remodel period, the contractor will be required to rent a 32-foot by 8-foot office trailer, complete with a restroom, kitchenette, and air conditioning, for use as a breakroom during the remodel period. Acceptable Manufacturer: Willscot, 5000 NW 72nd Ave, Miami FL 33166. Phone: (305) 592-7379.

2.0 Responsibilities of the Contractor in charge of the work

The contractor must obtain all permits, submit copies to the Project Manager before performing any work, and complete all work required within 120 days from the date of the Notice to Proceed. The contractor is responsible for verifying on-site measurements and verifies the kitchen layout. The contractor shall be responsible for restoring any damages to the existing finished surfaces and building components caused by the execution of this work. The contractor will be required to dispose of debris and old kitchen cabinets. The work area must be cleaned daily. Before the Notice to Proceed, the Contractor must submit an employee list of names of the workers who will be performing work at the facility to the project manager. DTPW personnel will perform background checks on each of those employees before issuing the required security clearance and provide DTPW badges to those working on the DTPW property. The employee list must include Name, DOB, and SSN. The contractor shall furnish skilled and licensed personnel on site. Your quote should include all of mentioned above. All work must follow guidelines as per Contract 7040. The contractor that is awarded the project must submit a project schedule before commencing work. DTPW requires contractors to attend site visits before bidding.

3.0 Time / Work Performed

Monday thru Friday from 7:00 a.m. to 4:00 p.m., additional times and weekends can be arranged with the DTPW project manager to expedite the installation. All work must be scheduled with DTPW personnel.

4.0 Warranty provided by the Contractor in charge of the work

All materials and workmanship of the installation that was provided by the contractor shall be guaranteed for a period of one year, and all factory warranties are to be applied.

SECTION 01 32 16

PROJECT SCHEDULE

1.01 DESCRIPTION:

- A. This section covers the preparation of a schedule in the Cost Loaded Construction in the Critical Path Method (CPM). The Contractor will be allowed to use his preferred scheduling system, if approved by DTPW. If the Contractor wishes to propose his own system, he shall so request prior to the required submittal time tables listed in this section.
- B. Final Schedule:
 - 1. A bar chart schedule shall be used by the Contractor to control the progress and time fixed for completion of this project. This system shall be implemented by the Contractor. Prior to approval of the final construction schedule, the Contractor shall provide work with letters from all his sub-contractors and suppliers indicating that they have reviewed the Contractor's schedule and concur with the sequence of events, activity durations and rates of production implied therein.
 - 2. All work shall be done in accordance with the schedule and all costs incurred by the Contractor to correctly implement the schedule shall be borne by the Contractor and are a part of his Contract.
 - 3. The schedule must be updated monthly and submitted with the Contractor's pay request. No payment will be made to the Contractor unless this monthly updated schedule and progress report is submitted with the Contractor's pay request. Even if no invoice is submitted in a particular month, the Contractor shall submit monthly schedule updates and progress reports to the satisfaction of work.

2.01 PREPARATION OF FINAL SCHEDULE:

- A. Within five (5) working days after the date of Notice to Proceed (NTP), such as FP the Contractor shall develop and submit a comprehensive and detailed final schedule. Work performed prior to NTP shall not be allowed under this Contract.
- B. When completed, the bar chart diagram shall represent the Contractor's own plan for the project as well as the sequence of each operation and all the involved parties. The schedule shall also identify the project's critical path. It shall be the responsibility of the Contractor to ensure that all of this work is described by the diagram and that the diagram does correctly represent the sequence in which he plans to do his work and the time in which he expects to do it.
- C. As a minimum, the final schedule will cover the following areas:
 - 1. Shop drawing preparation, review and approval

2. Procurement of major equipment, material and/or long-lead items
3. Permit acquisition activities
4. Material samples, as applicable
5. Material delivery
6. All major work elements as approved by the Engineer
7. Testing
8. Substantial Completion
9. Punch list activities
10. Rates of Production
11. Submittals
12. Work Elements by other &L, AT&T, etc...

D. The final schedule will be printed on a 11" x 17" sheet suitable for reproduction. The Contractor will submit three (3) copies of this schedule.

E. A written narrative on separate 8 1/2" x 11" sheets will be included with the Contractor's final schedule. This narrative will describe the Contractor's general approach for performing the work and any additional or unusual requirements not clearly represented in the schedule including, but not limited to, equipment to be used and the time equipment is to be on-site, anticipated delivery dates for material and/or equipment, crews and crew sizes, estimated quantities and rates of production. The narrative shall explain the basis for the Contractor's determination of durations for major work items and describe his approach for meeting the interim and final completion dates in his schedule. The narrative shall also address workdays per week, hours per shift, rain days, holidays or any other non-work periods that the Contractor is assuming in the planning of the work. Activities which may be expedited by the use of overtime or additional shifts shall be identified. Sequencing and other restraints such as manpower, material or equipment shall be identified and explained.

F. When completed, the final schedule shall be submitted to work for their approval. The Contractor shall incorporate work schedule review comments within ten (10) working days after receipt. DTPW shall be the final authority in deciding the acceptability of the schedule. Upon approval work, this shall become the Final Schedule for the Contract. No deviations from the final schedule will be allowed without the prior written approval of DTPW.

G. The Contractor shall identify all available float or slack time in his schedule in a format suitable to DTPW. Float or slack time is not for the exclusive use or benefit of either the Contractor or work. Float or slack time is considered project float as it is for the benefit of both parties. As such, it is not to be used exclusively by either party, but is to be used by the party that needs it first. No more than 15% to 25% of the activities in the Contractor's

schedule may be on or near the critical path ("Near the critical path" is defined as any activity having float of ten (10) days or less).

3.01 MONTHLY SCHEDULE UPDATES:

- A. The Contractor shall submit monthly schedule updates to show progress, as applicable, on all activities in progress. Such progress shall be shown in a format suitable to DTPW. Three (3) 11" X 17" copies of the updated schedule shall be submitted by the Contractor.
- B. The Contractor shall submit an updated narrative in the form of monthly progress reports in a format acceptable to work. Such reports shall include sections for describing "progress this period", "planned progress for next period", "problems and solutions" (including a listing of all delayed activities, the reasons for delay and proposed recovery actions) and "changes since last period". Any special concerns and or questions regarding the schedule should also be included in the progress report. Information included in the updated narrative will not relieve the Contractor of the notice requirements contained in the Contract documents. As applicable, signed material delivery tickets indicating when material was delivered on-site or to the fabrication plant will be provided with the narrative on a monthly basis.
- C. The Contractor shall submit on a weekly basis a simplified two-week look-ahead bar chart schedule showing all anticipated work scheduled to take place during the next fourteen (14) calendar days. This two-week look-ahead schedule shall be based on the approved baseline schedule.

4.01 PAY REQUESTS:

- A. The Contractor's pay request shall be based on completed activities and shall include an update of the final schedule. The Contractor will not be eligible to receive payment until his Contract baseline schedule and schedule of values is approved and no payment will be made to the Contractor unless this schedule update and schedule of values is submitted with the pay request.
- B. 5% of each Contractor's pay request amount will be held as retainage.
- C. All Contractor pay requests will be submitted in a form suitable to DTPW based on the approved schedule of values under the contract.
- D. No payment will be made to the Contractor for uncompleted activities.

5.01 MEASUREMENT AND PAYMENT:

- A. Work under this section will be paid for as part of the lump sum bid item unit prices in the bid form under this contract.

BASELINE NARRATIVE FORM FOR BAR CHART SCHEDULES

Contract Title: _____

Contract No.: _____

Contractor: _____

Baseline and/or Update No.: _____

1. Contractor's general approach for completing the work:

Including but not limited to any additional or unusual requirements not clearly represented in the schedule, the basis for the Contractor's determination of durations for major work items and his approach for meeting the interim and final completion dates in his schedule.

Use additional sheets if necessary.

2. Equipment to be used:

Including time that the equipment is to be on-site. Use additional sheets if necessary.

BASELINE NARRATIVE FORM FOR BAR CHART SCHEDULES

Contract Title: _____

Contract No.: _____

Contractor: _____

Baseline and/or Update No.: _____

3. Anticipated delivery dates for material/equipment:

Use additional sheets if necessary.

4. Crews and Crew Sizes:

Use additional sheets if necessary.

5. Rates of Production and Estimated Quantities:

Use additional sheets if necessary.

BASELINE NARRATIVE FORM FOR BAR CHART SCHEDULES

Contract Title: _____

Contract No.: _____

Contractor: _____

Baseline and/or Update No.: _____

6. Work Days per week/Hours per Shift:

Use additional sheets if necessary.

7. Non-work Periods assumed in the planning of the work:

Including holidays, rain days and any other non-work period assumed by the Contractor.

Use additional sheets if necessary.

8. Activities which may be expedited by the use of overtime or additional shifts:

Use additional sheets if necessary.

BASELINE NARRATIVE FORM FOR BAR CHART SCHEDULES

Contract Title: _____

Contract No.: _____

Contractor: _____

Baseline and/or Update No.: _____

9. Sequencing and other restraints affecting the work:

Including manpower, material and equipment restraints. Use additional sheets if necessary.

**MONTHLY SCHEDULE UPDATE NARRATIVE FORM FOR BAR CHART
SCHEDULES**

Contract Title: _____

Contract No.: _____

Contractor: _____

Baseline and/or Update No.: _____

1. Progress This Period:

Including all activities started, completed or in progress and signed material delivery tickets indicating when material was delivered on-site or to the fabrication plant as applicable.

Use additional sheets if necessary.

2. **Planned Progress for Next Period:**

Use additional sheets if necessary.

**MONTHLY SCHEDULE UPDATE NARRATIVE FORM FOR BAR CHART
SCHEDULES**

Contract Title: _____

Contract No.: _____

Contractor: _____

Baseline and/or Update No.: _____

ii. **Problems and Solutions:**

Including a listing of all delayed activities, the reasons for delay and proposed recovery actions. Use additional sheets if necessary.

- iii. **Changes Since Last Period:**
Use additional sheets if necessary.

MONTHLY SCHEDULE UPDATE NARRATIVE FORM FOR BAR CHART
SCHEDULES

Contract Title: _____

Contract No.: _____

Contractor: _____

Baseline and/or Update No.: _____

- iv. **Special Concerns and/or Questions regarding the Schedule:**
Use additional sheets if necessary.



END OF SECTION

SECTION 01 43 00

QUALITY CONTROL REQUIREMENTS

1.0: QUALITY CONTROL

The Contractor shall develop and submit an effective Quality Control Plan (QCP) to assure adequate quality throughout all phases of the Contract Work and shall describe the methods used and means employed for the implementation of the plan. The QCP shall ensure compliance with the requirements of the contract documents within the Contractor's, subcontractor's and supplier's organizations.

A QCP template shall be attached to the contract documents to be used as guidance in the development of the Contractor's QCP.

2.0: ORGANIZATION

- 2.1 Personnel performing Quality Control (QC) functions shall have sufficient, well-defined responsibility, authority and the organizational freedom to identify and evaluate quality problems, and to initiate, recommend or provide solutions.
- 2.2 The Contractor's QCP shall be subject to DTPW's verification at any time. Verification may include but not be limited to:
 - 1. Surveillance of the operations.
 - 2. Auditing of records and activities.
 - 3. Inspection to measure quality of items and/or works to ensure compliance with requirements.
 - 4. Review of Quality Records to ensure proper records keeping of activities affecting quality. These records shall be available for review by DTPW at any time.

3.0: APPLICABILITY

The responsibility for providing QC disciplines to verify that the work is performed in accordance with the Contract document rests with the Contractor. The Contractor's QCP shall be used to control quality throughout the duration of the project. Any inspections, audits or tests provided by DTPW or designee shall not relieve the Contractor of the responsibility of providing work that strictly complies with the Contract requirements.

4.0: REQUIREMENTS

The Contractor's QCP shall be in-line with the Contract documents and shall also include:

- 4.1 An organizational chart indicating lines of authority and reporting relationship including QC personnel.
- 4.2 Detailed Quality Procedures and Inspection Forms.
 - 1. The QCP and associated quality procedures and inspection forms should be submitted to DTPW within five (5) days after Notice to Proceed (NTP) for review and approval.
 - 2. Additional information may be required by DTPW to assure acceptability of the Contractor's QCP.
- 4.3 Records for all material tests, audits, and inspections performed, including data on conforming as well as nonconforming items shall be maintained by the Contractor at the job site current, up to date, and available for DTPW inspection at any time throughout the contract work.

- 4.4 Test Records and Calibration Identification status of testing equipment required for the project shall be maintained by the Contractor and available for inspection by DTPW at any time throughout the contract work.

5.0: NONCONFORMANCE AND REPAIR ACTION

- 5.1 The Contractor shall maintain an effective system for controlling nonconforming material, including procedures for its identification, segregation, and disposition.
- 5.2 All nonconforming material shall be positively identified to prevent unauthorized use, shipment, or intermingling with conforming material. Disposition for the use or repair of nonconforming material shall require the approval of DTPW.
- 5.3 The Contractor shall be responsible for all costs associated with the removal of components and/or devices, the shipping charges to and from the Contractor's facilities and the costs associated with their reinstallation and/or repair.

PROJECT QUALITY CONTROL PLAN

PROJECT TITLE

PROJECT/CONTRACT NUMBER

COMPANY NAME

REVISION DATE

COMPANY NAME: _____

Revision Date: mm/dd/yyyy

PROJECT QUALITY CONTROL PLAN

SIGNATURE SHEET

This Quality Control Plan dated: _____ was prepared in accordance with the project/contract requirements.

Prepared by:

Title: _____ Print Name _____ Signature: _____

Approved by:

Title: _____ Print Name _____ Signature: _____

COMPANY NAME: _____

Revision Date: mm/dd/yyyy

PROJECT QUALITY CONTROL PLAN

TABLE OF CONTENTS

QUALITY ELEMENTS

PAGE

1. CONTRACTOR'S ORGANIZATION
2. DOCUMENT CONTROL
3. PURCHASING & PRODUCT/MATERIAL IDENTIFICATION
4. CALIBRATION OF INSPECTION AND TEST EQUIPMENT
5. INSPECTION AND TESTING
6. CONTROL OF NONCONFORMANCES
7. QUALITY RECORDS
8. TRAINING

APPENDICES

PROJECT QUALITY CONTROL PLAN

1. CONTRACTOR'S ORGANIZATION

ORGANIZATIONAL CHART

(Insert the company's organizational chart on this page)

PROJECT QUALITY CONTROL PLAN

Roles & Responsibilities:

In this section, document the roles, responsibilities, relevant experience, and qualifications of key personnel (by functional position only) assigned to the project:

Example Positions:

Project Manager:

Quality Control Representative:

Inspection Personnel:

PROJECT QUALITY CONTROL PLAN

2. Document Control

In this section, identify which documents will be controlled to ensure that they are maintained and current throughout the project:

Example of a list of Documents to Identify & Control:

- *Contractor's Quality Control Plan (QCP)*
- *Contractor's Inspection Procedures*
- *Contractors Work Instructions*
- *Drawings*

PROJECT QUALITY CONTROL PLAN

3. Purchasing & Product/Material Identification

Contractor's input:

In this section, document how products/materials that will be used in this project are procured, received, and inspected to ensure that they are in good condition and the correct part has been purchased.

Approved Supplier List

The Contractor shall develop and maintain an approved Supplier list.

PROJECT QUALITY CONTROL PLAN

4. Calibration of Inspection & Test Equipment

Contractor's input:

In this section, identify which inspection and test equipment will be identified, calibrated, and maintained to ensure accuracy of the inspections and testing as required. Also, identify the calibration intervals or frequency for each equipment that is subject to calibration.

PROJECT QUALITY CONTROL PLAN

5. Inspection and Testing

Contractor's input:

In this section, document:

1. *The types of inspections/testing to be performed*
2. *The procedures/forms to be used to perform the inspections and/or testing*
3. *Quality Control activities during the different phases of inspection*
 - a. *Preparatory meetings*
 - b. *Initial inspections*
 - c. *Follow-up inspections*
 - d. *Final inspections*

PROJECT QUALITY CONTROL PLAN

6. Control of Non-conformances

Contractor's input:

In this section, document:

- 1. The method to be used to identify, document, evaluate and address nonconforming products. It is highly recommended that a log of non-conformances, Punch List items is kept and that it includes the corrective actions to address the non-conformances.*
- 2. The method to be used to implement a corrective action plan to address all non-conformances. It is highly recommended that a log be kept to track all non-conformances and the proposed corrective action plans as necessary.*

PROJECT QUALITY CONTROL PLAN

7. Quality Records

Contractor's input:

In this section, identify which quality records will be controlled and the process to ensure that they are maintained, stored and dispositions appropriately:

Example of Quality Records:

- *Inspection Reports*
- *Test Data*
- *Calibration Records*
- *Nonconformance Reports*
- *Corrective Action Reports*
- *Audit Reports*
- *Training Records*
- *Product Certification*

PROJECT QUALITY CONTROL PLAN

8. TRAINING

Consultant input:

In this section, document the training program, personnel qualification and any certification needed as necessary:

PROJECT QUALITY CONTROL PLAN

APPENDICES

Contractor's input:

In this section, the Contractor may include any references, procedures, process flow charts, forms and acronyms/definitions that apply to this project:

SECTION 01 62 00

SUBSTITUTIONS AND PRODUCT OPTIONS

1.01 DESCRIPTION:

- A. This Section specifies the procedures to be followed for preparing, submitting, amending and updating of lists of products proposed to be incorporated in the work.

2.01 SELECTED PRODUCTS:

- A. Within ten (10) days after the effective date of NTP, submit five (5) copies of the list of selected products. Arrange the list in the order of each Section's appearance in the specification.
 1. For products specified only by reference standards, any product satisfying those standards may be selected. Show name and address of manufacturer; trade name, model number or catalog designation of the product; manufacturer's reference standards and pertinent performance and test data.
 2. For products specified by naming one product or by naming several products, this establishes a product standard. Any other product, which is equal in the opinion of DTPW and EOR may be furnished. A request must be submitted to the DTPW as required for substitutions, for acceptance of products not specifically named.
 3. **Approve Equal:** Where named products or sources are accompanied by the term "or equal" or other language of similar effect, provide one of the specified products, or submit a request for substitution for a product not named, in accordance with the requirements of Section 01 62 00 – Substitutions and Product Options, which the Contractor judges to be of equal or better quality.
 4. Amend and update list as changes concerning the information become known.

3.01 LIST OF SUBSTITUTE PRODUCTS AND METHODS:

- A. Formal requests from the Contractor will be considered by DTPW and EOR for substitution of products and methods in place of those specified, but only if these requests are submitted within ten (10) days after effective date of NTP. No substitutions request will be considered after ten (10) days. Acceptance of substitute products and methods shall be only for the characteristics and use named in the acceptance, and shall be interpreted neither as a modification to the Specification and Drawing requirements nor to establish acceptance of products and methods for other portions of the Transit System. DTPW and the EOR shall judge the quality and suitability of the substitute product and method and his decision shall

be final. Where use of a substitute product and method involves redesign of other parts of the work, the cost and time required to affect that redesign will be considered in evaluating the suitability of the substitute product and method.

B. Submit five (5) copies of list of substitute products and methods, including the following information:

1. Complete data substantiating compliance of the proposed substitution with the requirements of the Specifications and Drawings.
2. For products:
 - a. Product identification, including manufacturer's name and address
 - b. Manufacturer's literature, including product description, performance and test data and pertinent reference standards
3. For construction methods:
 - a. Detailed description of proposed method
 - b. working drawings illustrating methods
4. Itemized comparison of proposed substitution with product specified. Comparison shall include cost, differences in estimated life, estimated maintenance, availability of spare parts and repair services, energy consumption, performance capacity, salvage-ability, manufacturer's warranties and other material differences.
5. Data relating to changes in construction schedule.
6. Accurate cost data on proposed substitution in comparison with product and method specified except that cost data will not be required on substitutes proposed as equal, equivalent or superior to specified brand names and for which no request is made for price adjustment to the sub-contract.
7. Equitable adjustment and credit that the Contractor proposes to offer work if the substitutions are not equal, equivalent or superior to specified brand names.

C. In making request for substitution, Contractor shall verify:

1. That he has personally investigated the proposed product and method and that to the best of his knowledge, information and belief, the product and method is either equivalent or superior to that product and method specified and that he will update information as new or different data become known to him.

2. That he will furnish the same guarantee for substitution as he would for the product and method specified.
 3. That he will coordinate installation of the accepted substitution into the work and will make those changes required for the work to be complete and operable.
 4. That cost data is complete and includes related costs and excludes cost of engineering redesign.
 5. That he waives claims for additional time and costs related to the substitution, which become apparent.
- D. Amend and update list as changes concerning information on the list become known to him.
- E. Substitutions will not be considered, if indicated or implied on Shop Drawings or Product Data submittal for which no formal request for substitution has been submitted. Requests for substitutions will not be considered if acceptance will require substantial revisions of drawings and specifications or both.

4.01 MEASUREMENT:

- A. Work under this section will not be separately measured for payment.

5.01 PAYMENT:

- A. Work under this section will be paid for as part of the lump sum bid item unit prices in the bid form under this contract.

END OF SECTION

SECTION 01 78 36

WARRANTIES

PART 1: WARRANTY

1.01 DESCRIPTION OF WORK:

- A. The warranties provided by the Contractor shall be for the longest period, starting on the date of final acceptance, of those specified as follows:
 - 1. One (1) year from final acceptance on all the work as specified in the Contract.
 - 2. Warranty period(s) as specified by the approved material or equipment manufacturers.
 - 3. Longer warranty period(s) as specified in the technical specifications.
- B. The Contractor shall provide certifications and other commitments, extended warranties and agreements for continuing services as specified elsewhere in the Contract Documents.

1.02 DISCLAIMERS AND LIMITATIONS:

- A. Manufacturer's disclaimers and limitations on product warranties do not relieve the Contractor of the warranty on the work that incorporates the products, nor does it relieve suppliers, manufacturers, and sub-contractors required to countersign special warranties with the Contractor.

1.03 DEFINITIONS:

- A. Standard product warranties are reprinted written warranties published by the individual manufacturers for particular products and are specially endorsed by the manufacturer to Department of Transportation and Public Works (work).

1.04 WARRANTY REQUIREMENTS:

- A. Related Damages and Losses:

When correcting warranted work that has failed, remove and replace other work that has been damaged as a result of such failure or that must be removed and replaced to provide access for correction of warranted work.

B. Reinstatement of Warranty:

When work covered by a warranty has failed and been corrected by replacement or rebuilding, reinstate the warranty by written endorsement. The reinstated warranty shall be equal to the original warranty with an equitable adjustment for depreciation.

C. Replacement Cost:

Upon determination that work covered by a warranty has failed, replace or rebuild the work to an acceptable condition complying with requirements of Contract Documents. The Contractor is responsible for the cost of replacing or rebuilding defective work regardless of whether the DTPW has benefited from use of the work through a portion of its anticipated useful service life.

D. DTPW Recourse:

Written warranties made to the owner are in addition to implied warranties, and shall not limit the duties, obligations, rights and remedies otherwise available under the law, nor shall warranty periods be interpreted as limitations on time in which the work can enforce such other duties, obligations, rights or remedies.

E. Contractor shall provide a written guarantee, to the work, that proprietary parts and oil absorption material or their generic equal will be made available to the work at least for 10 years from the date of the system start-up.

F. Rejection of Warranties:

Work reserves the right to reject warranties and to limit selections to products with acceptable warranties and to limit selections to products with warranties not in conflict with requirements of the Contract Documents.

G. The DTPW reserves the right to refuse to accept work for the project where a special warranty, certification, or similar commitment is required on such work or part of the work, until evidence is presented that entities required to countersign such commitments are willing to do so.

H. All warranties including standard three (3) year warranty shall start at date of substantial completion of the Contract, or when work of an area is substantially completed, accepted and taken over for use by DTPW. Ensure that all warranties comply with this stipulation prior to submission of same.

I. The DTPW will give prompt notice in writing to the Contractor of any defects noted during the warranty periods requesting him to promptly remedy such defects.

J. Prior to final acceptance, the Contractor shall formally assign to DTPW all extended warranties given by sub-contractors for their work on the project, and such sub-contractor shall be formally advised of the assignment.

- K. Asset life expectancy : Contractor to provide the necessary documents securing the life expectancy at no less than 25 years
- L. Asset maintenance : As per grant agreements asset are to be maintained by the municipality

1.05 SUBMITTALS:

- A. Submit written warranties to DTPW prior to the date of the final acceptance inspection.
- B. When a special warranty is required to be executed by the Contractor, or the Contractor and a sub-contractor, supplier or manufacturer, prepare a written document that contains appropriate terms and identification, ready for execution by the required parties. Submit a draft to the DTPW for approval prior to final execution.
- C. Submit a list of all warranty items within ten (10) days after notice to proceed.
- D. Prior to final acceptance compile two (2) copies of each required warranty, and bond properly executed by the Contractor, or by sub-contractor, supplier or manufacturer.
- E. Bind warranties and bonds in heavy duty, commercial quality, durable 3-ring vinyl covered loose leaf binders, thickness as necessary to accommodate contents, and sized to receive 8 1/2 inch by 11 inch paper.
- F. Provide heavy paper dividers with celluloid covered tabs for each separate warranty. Mark the tab to identify the product or installation. Provide a typed description of the product or installation, including the name of the product, and the name, address and telephone number of the installer.
- G. Identify each binder on the front and the spine with the typed or printed title, "WARRANTIES AND BONDS", the project title or name, and the name of the Contractor.
- H. When operating and maintenance manuals are required for warranted construction, provide additional copies of each required warranty, as necessary, for inclusion in each required manual.

1.06 MEASUREMENT:

- A. Work under this section will not be separately measured for payment.

1.07 PAYMENT:

- A. Work under this section will be paid for as part of the lump sum bid item unit prices in the bid form under this contract.

END OF SECTION

KITCHEN SPECIFICATIONS

AMERICAN STANDARD FAUCET COLONY PRO

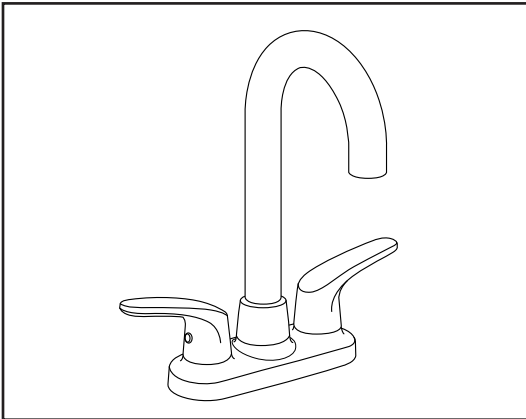

MODEL NUMBER:

- ☐ **7074.400** Centerset Bar Sink Faucet
Lever handles.

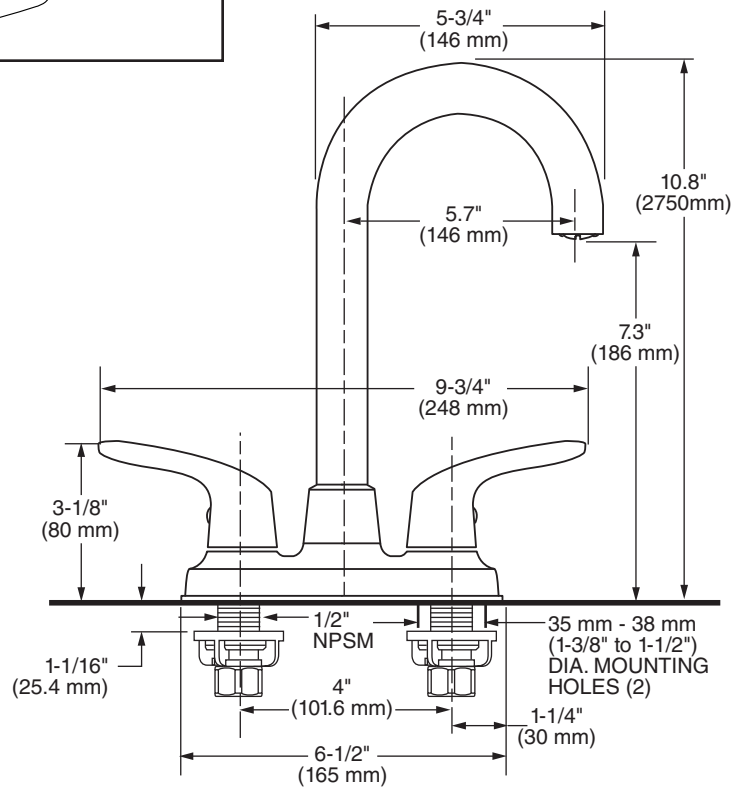

GENERAL DESCRIPTION:

Durable metal construction. 1/4 turn washerless ceramic disc valve cartridges. One-half inch male inlet shanks. Brass gooseneck swivel spout (360° rotation). 1.5 gpm/5.7 L/min. maximum flow rate.

PRODUCT FEATURES:

- Ceramic Disc Valve Cartridge:** Assures a lifetime of drip-free performance.
- Brass Swivel Spout:** Durable. Ideal for prolonged contact with water. Rotates 360°.
- Lead Free:** Faucet contains ≤ 0.25% total lead content by weighted average.
- Choice of finishes:** Available in Polished Chrome or Stainless Steel (PVD).

SUGGESTED SPECIFICATION

Centerset bar sink faucet shall feature brass swivel spout and 1/4 turn washerless ceramic disc valve cartridges. Fitting shall be American Standard Model # 7047.400. _____.



COLONY® PRO
TWO-HANDLE CENTERSET BAR SINK FAUCET
 WITH BRASS GOOSENECK SPOUT

CODES AND STANDARDS

These products meet or exceed the following codes and standards:

- ANSI A117.1**
- ASME A112.18.1**
- CSA B125.1**
- NSF 61/Section 9**
- NSF 372**

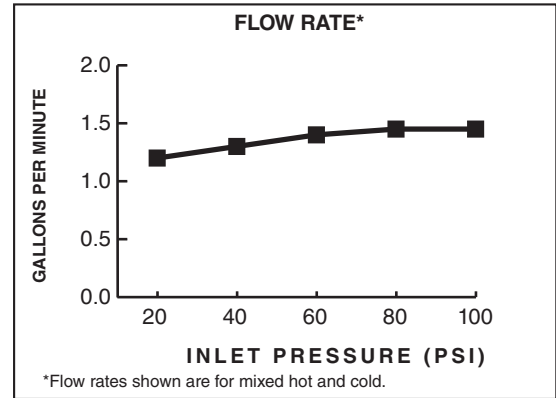

1.5 gpm/5.7 L/min. FLOW RATE

Product Number	Description	Finish Options	
		Polished Chrome	PVD Stainless Steel
		002	075
7074.400	Bar Sink faucet. Lever handles.		

 Meets the American Disabilities Act Guidelines and **ANSI A117.1** Requirements for the physically challenged.

KITCHEN SINK SPECIFICATIONS

Kitchen Sink Specifications.

Brand: Glacier Bay.

25 inches Drop in single bowl.

20 gauge.

Stainless steel.

WEATHER STRONG KITCHEN CABINETS

Kitchen brand: Weather Strong from Home Depot.

Color: Daytona Reef Blue.

Countertop: 8 ft gray laminate waterfall edge in Sea Salt with backsplash.

***Note: The microwave cabinet must be built on-site with additional panels.**

<u>REF #</u>	<u>SKU</u>	<u>QTY</u>	<u>UM</u>	<u>DESCRIPTION</u>
S1717	1005-469-786	1.00	EA	FS330A / FS330A 3" Wide Base Filler / FS330A HINGES: L
S1718	1005-469-786	1.00	EA	B30IB / B30IB 30x24x34.5 Base / B30IB HINGES: L
S1719	1005-469-786	1.00	EA	SB30IB / SB30IB SB 30x24x34.5 Sink Base / SB30IB HINGES: L
S1720	1005-469-786	1.00	EA	B3D15IB / B3D15IB 3 DR 15x24x34.5 Base / B3D15IB HINGES: L
S1721	1005-469-786	1.00	EA	BEP24 / BEP24 Base End Panel 24.875x36 / BEP24 FSIDES: R HINGES: L Mods: W=0 5/8 " H=34 1/2 " D=24"
S1722	1005-469-786	1.00	EA	FS330A / FS330A 3" Wide Wall Filler {3" X 30" High / FS330A FSIDES: R HINGES: L
S1723	1005-469-786	1.00	EA	W3015IB / W3015IB 30x15 Wall / W3015IB HINGES: L
S1724	1005-469-786	1.00	EA	W3030IB / W3030IB 30x30 Wall / W3030IB HINGES: L
S1725	1005-469-786	1.00	EA	W1530RIB / W1530RIB 15x30 Wall / W1530RIB HINGES:R
S1726	1005-469-786	9.00	EA	DH-21021 / DH-21021 Bar Pull SS 7" / DH-21021 HINGES: L
S1727	1005-469-786	5.00	EA	DH-21021 / DH-21021 Bar Pull SS 7" / DH-21021 HINGES: L
S1728	1005-469-786	3.00	EA	STAINLESS-LEGS-4PK / STAINLESS-LEGS-4PK Stainless Steel Leg P / STAINLESS-LEGS-4PK HINGES: L
S1729	1005-469-786	1.00	EA	FS696A / FS696A 6" Toe Kick/Filler Strip - Toe Kick / FS696A HINGES: L
S1730	1005-469-786	5.00	EA	BEP24 / BEP24 Base End Panel 24.875x36 / BEP24 HINGES: L*
S17FR	0000-106-587	1.00		YOW/HDD NON-STANDARD CHRGS-CALL FOR \$

EEMA SPEX 90 WATER HEATER

MODEL; SPEX90T

9kW 277V Electric Tankless Water Heater

LavAdvantage™

Thermostatic Heater Ideal for Handwashing and Other Fixed or Variable Flow Applications

Specifications

Tankless Electric Water Heater

Applications

- Handwashing
- Kitchen, bar, utility sinks
- Fixed or variable flow
- Ideal for multiple sensor or metering faucets
- Eyewash (EE models - 90°F max)
- Sanitation (S models - 180°F)

Features

- Self-diagnostics with intelligent controls actively protect heater installed environment
- SafeStart™ technology engages upon start-up to help avoid dry-fire occurrence
- Industry leading activation with 0.2 GPM turn on flow
- Digital LED display with accessible user interface communicates system status and heater operation feedback
- Silent operation on all models except for SPEX012240T
- Mounts in any orientation for a flexible installation
- Compact size fits almost anywhere; suitable for ADA compliant facilities
- Only one input line, hot or cold, needed for an easy installation
- Designed to deliver hot water to a single pipe faucet, mixing valves or mixing faucets
- Integral 3/8" compression fittings; no soldering or sweat connections required
- No T&P relief valve needed (check local codes)
- Save water and time by installing unit at the point-of-use
- Control system activates heater only on demand
- High temperature limit switch enables safe operation
- Active energy management with power modulation allows for thermostatic accuracy
- 5-year limited warranty on leaks, 1-year on parts

Product Specifications

Dimensions:	10.75" H x 5.25" W x 3" D
Product Weight: (model dependent)	4 lb
Cover:	ABS-UL rated 94 5VA
Color:	White
Adj. Temperature Range:	70°F-140°F*
Min. Operating Pressure:	30 PSI
Max. Operating Pressure:	150 PSI
Element:	Replaceable Nichrome cartridge insert
Fittings:	3/8" compression fittings
UL listed file number:	E86887

U.S. Patent #'s: 4,762,980 and 4,960,976

Special Design Service

Inquiries for units for unique applications are welcome. Call our Technical Service department at **1 800 543 6163**.

*Special settings available, see specification options

NOTE: Unit should not be used in a recirculation application. Contact an EEMAX representative for alternative recommendations.



Mount in any Orientation



SafeStart™ Technology



Tested and certified by the Water Quality Association against NSF/ANSI 372 for lead free compliance.

NO LEAD*

*The wetted surface of this product contacted by water contains less than 0.25% lead and meets NSF/ANSI 372



Note: For optimum performance, mounting location should be located within 2 feet of fixture.

Suggested Specification

Tankless water heater shall be an Eemax LavAdvantage model number SPEX **SPEX90T**

Unit shall have ABS-UL 94 5VA rated cover. Unit shall allow mounting in any direction. Element shall be replaceable cartridge insert. Unit shall have replaceable filter in the inlet connector. Element shall be iron free, Nickel Chrome material. Tankless water heater to utilize complex algorithm, actively managing power application to real time system demand. Integrated flow meter, along with inlet and outlet temperature sensors provide data which allows the unit to instantly adapt to variations in input parameters. Heater shall be fitted with 3/8" compression fittings to eliminate need for soldering. Maximum operating pressure of 150 PSI. Accessible diagnostic features to include error/fault display. Hot water storage tanks prohibited. Unit shall be Eemax or approved equal.

Tankless water heater user interface must have the following capabilities:

- Field serviceable elements
- Selectable display including Celsius /Fahrenheit, setpoint, flow rate, inlet temperature outlet temperature, power factor
- Capable of displaying flow rate in gallons per minute & liters per minute
- Diagnostic features to include error/fault display
- Control board must maintain error/fault history of 5 events

Specification options to be included with SPEX models:

- ___ **EE** Emergency Eyewash. Meets ANSI tepid water
- ___ **ML** Multiple Lavatory. Factory set to 110°F. Max temp. 110°F
- ___ **S** Sanitation. Factory set to 120°F. Max temp. 180°F
- ___ **N4** NEMA 4 steel cabinet with powder coat finish
- ___ **N4X** NEMA 4 stainless steel, corrosion-resistant cabinet
- EX68031-15** Disconnect Switch (see page 42-43)

MODEL NUMBER	KW	TOTAL AMP DRAW	CIRCUITS REQUIRED X BREAKER SIZE	RECOM'D WIRE SIZE (75° C/CU)	TURN ON (GPM)	TEMPERATURE RISE °F			
						0.35 GPM	0.5 GPM	1.0 GPM	2.0 GPM
VOLTS 120									
C SPEX1812T	1.8	15	(1x15)	14 AWG	0.2	35°	25°	12°	6°
C SPEX1812T EE	1.8	15	(1x15)	14 AWG	0.2	**	25°	12°	6°
C SPEX1812T S	1.8	15	(1x15)	14 AWG	0.2	35°	25°	12°	6°
C SPEX2412T	2.4	20	(1x20)	14 AWG	0.2	47°	33°	16°	8°
C SPEX2412T EE	2.4	20	(1x20)	14 AWG	0.2	**	33°	16°	8°
C SPEX2412T S	2.4	20	(1x20)	14 AWG	0.2	47°	33°	16°	8°
C SPEX3012T	3.0	25	(1x25)	12 AWG	0.2	59°	41°	20°	10°
C SPEX3012T EE	3.0	25	(1x25)	12 AWG	0.2	**	41°	20°	10°
C SPEX3012T S	3.0	25	(1x25)	12 AWG	0.2	59°	41°	20°	10°
C SPEX3512T	3.5	30	(1x30)	10 AWG	0.2	68°	48°	24°	12°
C SPEX3512T EE	3.5	30	(1x30)	10 AWG	0.2	**	48°	24°	12°
C SPEX3512T ML	3.5	30	(1x30)	10 AWG	0.2	68°	48°	24°	12°
C SPEX3512T S	3.5	30	(1x30)	10 AWG	0.2	68°	48°	24°	12°
VOLTS 240*									
C SPEX35T	3.5	15	(1x15)	14 AWG	0.2	68°	48°	24°	12°
C SPEX35T (derated 208V perf.)	2.7	13	(1x15)	14 AWG	0.2	53°	37°	18°	9°
C SPEX35T EE	3.5	15	(1x15)	14 AWG	0.2	**	48°	24°	12°
C SPEX35T ML	3.5	15	(1x15)	14 AWG	0.2	68°	48°	24°	12°
C SPEX35T S	3.5	15	(1x15)	14 AWG	0.2	68°	48°	24°	12°
C SPEX48T	4.8	20	(1x20)	14 AWG	0.2	94°	66°	33°	16°
C SPEX48T (derated 208V perf.)	3.6	17	(1x20)	14 AWG	0.2	70°	49°	25°	12°
C SPEX48T EE	4.8	20	(1x20)	14 AWG	0.2	**	†	33°	16°
C SPEX48T ML	4.8	20	(1x20)	14 AWG	0.2	94°	66°	33°	16°
C SPEX48T S	4.8	20	(1x20)	14 AWG	0.2	94°	66°	33°	16°
C SPEX55T	5.5	23	(1x25)	12 AWG	0.2	107°	75°	38°	19°
C SPEX55T (derated 208V perf.)	4.1	20	(1x20)	14 AWG	0.2	80°	56°	28°	14°
C SPEX55T EE	5.5	23	(1x25)	12 AWG	0.2	**	†	38°	19°
C SPEX55T ML	5.5	23	(1x25)	12 AWG	0.2	107°	75°	38°	19°
C SPEX55T S	5.5	23	(1x25)	12 AWG	0.2	107°	75°	38°	19°
C SPEX65T	6.5	27	(1x30)	10 AWG	0.2	†	89°	44°	22°
C SPEX65T (derated 208V perf.)	4.9	23	(1x25)	12 AWG	0.2	96°	67°	33°	17°
C SPEX65T EE	6.5	27	(1x30)	10 AWG	0.2	**	†	44°	22°
C SPEX65T ML	6.5	27	(1x30)	10 AWG	0.2	†	89°	44°	22°
C SPEX65T S	6.5	27	(1x30)	10 AWG	0.2	127°	89°	44°	22°
C SPEX75T	7.5	32	(1x40)	10 AWG	0.2	†	102°	51°	26°
C SPEX75T (derated 208V perf.)	5.6	27	(1x30)	12 AWG	0.2	109°	76°	38°	19°
C SPEX75T EE	7.5	32	(1x40)	10 AWG	0.2	**	†	51°	26°
C SPEX75T ML	7.5	32	(1x40)	10 AWG	0.2	†	102°	51°	26°
C SPEX75T S	7.5	32	(1x40)	10 AWG	0.2	146°	102°	51°	26°
C SPEX95T	9.5	40	(1x40)	8 AWG	0.2	†	†	65°	32°
C SPEX95T (derated 208V perf.)	7.0	34	(1x40)	8 AWG	0.2	†	96°	48°	24°
C SPEX95T EE	9.5	40	(1x40)	8 AWG	0.2	**	†	†	32°
C SPEX95T ML	9.5	40	(1x40)	8 AWG	0.2	†	†	65°	32°
C SPEX95T S	9.5	40	(1x40)	8 AWG	0.2	†	103°	65°	32°
C SPEX012240T	11.5	48	(1x50)	8 AWG	0.2	†	†	79°	39°
C SPEX012240T (derated 208V perf.)	8.7	42	(1x50)	8 AWG	0.2	†	†	59°	30°
C SPEX012240T EE	11.5	48	(1x50)	8 AWG	0.2	**	†	†	39°
C SPEX012240T ML	11.5	48	(1x50)	8 AWG	0.2	†	†	79°	39°
C SPEX012240T S	11.5	48	(1x50)	8 AWG	0.2	†	†	79°	39°

* 240V units can be used on 208V single phase with 25% reduced temperature output. Please note per UL standards the rating plate and installation instructions will all be according to a 240V applied voltage. Check with local officials prior to derating the electrical infrastructure.

† Temperature electronically limited to factory preset not to exceed temperature.

“C” indicates evaluation and compliance to either Underwriters Laboratories (UL) or Intertek (ETL) under CAN/CSA-C22.2 No. 64/No. 88.

** Per ANSI Z358.1-2014 minimum flow of an eyewash station is 0.4 GPM @ 30 PSI.

NOTE: Unit should not be used in a recirculation application. Contact an EEMAX representative for alternative recommendations.

MODEL NUMBER	KW	TOTAL AMP DRAW	CIRCUITS REQUIRED X BREAKER SIZE	RECOM'D WIRE SIZE (75° C/CU)	TURN ON (GPM)	TEMPERATURE RISE °F			
						0.35 GPM	0.5 GPM	1.0 GPM	2.0 GPM
VOLTS 208 Single Phase									
C SPEX3208T	3.0	15	(1x15)	14 AWG	0.2	59°	41°	20°	10°
C SPEX3208T ML	3.0	15	(1x15)	14 AWG	0.2	59°	41°	20°	10°
C SPEX4208T	4.1	20	(1x20)	14 AWG	0.2	80°	56°	28°	14°
C SPEX4208T EE	4.1	20	(1x20)	14 AWG	0.2	**	56°	28°	14°
C SPEX4208T ML	4.1	20	(1x20)	14 AWG	0.2	80°	56°	28°	14°
C SPEX4208T S	4.1	20	(1x20)	14 AWG	0.2	80°	56°	28°	14°
C SPEX8208T	8.3	40	(1x40)	8 AWG	0.2	†	†	57°	28°
C SPEX8208T EE	8.3	40	(1x40)	8 AWG	0.2	**	†	57°	28°
C SPEX8208T ML	8.3	40	(1x40)	8 AWG	0.2	†	†	57°	28°
C SPEX8208T S	8.3	40	(1x40)	8 AWG	0.2	†	†	57°	28°
VOLTS 277 Single Phase									
SPEX3277T	3.0	11	(1x15)	14 AWG	0.2	59°	41°	20°	10°
SPEX3277T EE	3.0	11	(1x15)	14 AWG	0.2	59°	41°	20°	10°
SPEX3277T ML	3.0	11	(1x15)	14 AWG	0.2	59°	41°	20°	10°
SPEX3277T S	3.0	11	(1x15)	14 AWG	0.2	59°	41°	20°	10°
SPEX4277T	4.1	15	(1x15)	14 AWG	0.2	80°	56°	28°	14°
SPEX4277T EE	4.1	15	(1x15)	14 AWG	0.2	**	56°	28°	14°
SPEX4277T ML	4.1	15	(1x15)	14 AWG	0.2	80°	56°	28°	14°
SPEX4277T S	4.1	15	(1x15)	14 AWG	0.2	80°	56°	28°	14°
SPEX60T	6.0	22	(1x25)	12 AWG	0.2	†	82°	41°	20°
SPEX60T EE	6.0	22	(1x25)	12 AWG	0.2	**	†	41°	20°
SPEX60T ML	6.0	22	(1x25)	12 AWG	0.2	†	82°	41°	20°
SPEX60T S	6.0	22	(1x25)	12 AWG	0.2	117°	82°	41°	20°
SPEX80T	8.0	29	(1x30)	10 AWG	0.2	†	109°	55°	27°
SPEX80T EE	8.0	29	(1x30)	10 AWG	0.2	**	†	55°	27°
SPEX80T ML	8.0	29	(1x30)	10 AWG	0.2	†	109°	55°	27°
SPEX80T S	8.0	29	(1x30)	10 AWG	0.2	†	109°	55°	27°
PEX90T	9.0	33	(1x35)	10 AWG	0.2	†	†	61°	31°
SPEX90T EE	9.0	33	(1x35)	10 AWG	0.2	**	†	†	31°
SPEX90T ML	9.0	33	(1x35)	10 AWG	0.2	†	†	61°	31°
SPEX90T S	9.0	33	(1x35)	10 AWG	0.2	†	123°	61°	31°
SPEX100T	10.0	36	(1x40)	8 AWG	0.2	†	†	68°	34°
SPEX100T EE	10.0	36	(1x40)	8 AWG	0.2	**	†	†	34°
SPEX100T ML	10.0	36	(1x40)	8 AWG	0.2	†	†	68°	34°
SPEX100T S	10.0	36	(1x40)	8 AWG	0.2	†	137°	68°	34°

Suffix Definitions

- EE** Meets ANSI Z358.1 tepid water requirements. Max. temperature 90°F
- ML** Multi lavs 0.2 turn on with 110° temp setting
- S** Sanitation not to exceed 180°

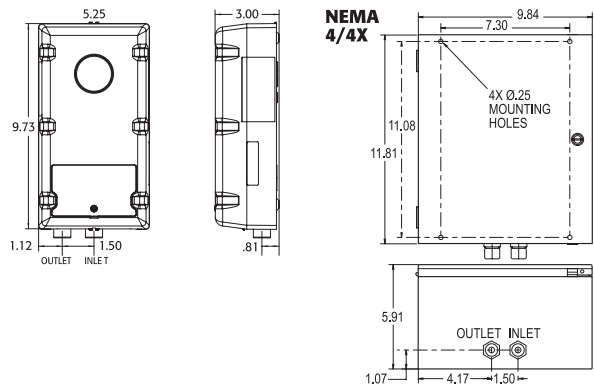

WILLSCOT TRAILER

32' x 8' OFFICE TRAILER



In addition to your office solution, we can provide additional products and services that complete your space- creating a more productive, comfortable, and safe work environment.

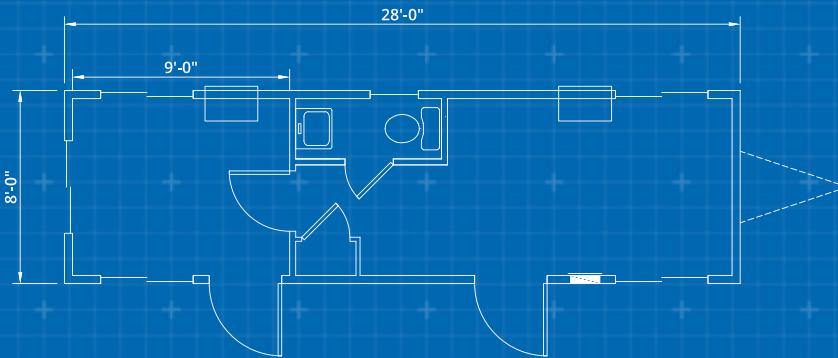

CUSTOMIZATION

- Steps & Ramps
- Furniture & Appliances
- Technology
- Site Services
- Loss Protection

Dimensions

- 32' Long (including hitch)
- 28' Box size
- 8' Wide
- 7' Ceiling height

Exterior Finish

- Aluminum or wood siding
- I-Beam Frame
- Standard drip rail gutters

Interior Finish

- Paneled walls
- Carpet or vinyl tile floor
- Gypsum ceiling

Electric

- Fluorescent ceiling lights
- Breaker panel

Heating/Cooling

- Electric baseboard heat and thru-wall AC unit or combination heat/AC unit

Windows/Doors

- Horizontal slider windows
- (2) Vision panel doors with standard locks or (2) steel doors with dead bolt lock

Other

- Private office(s)
- Optional restroom

KITCHEN DESIGN

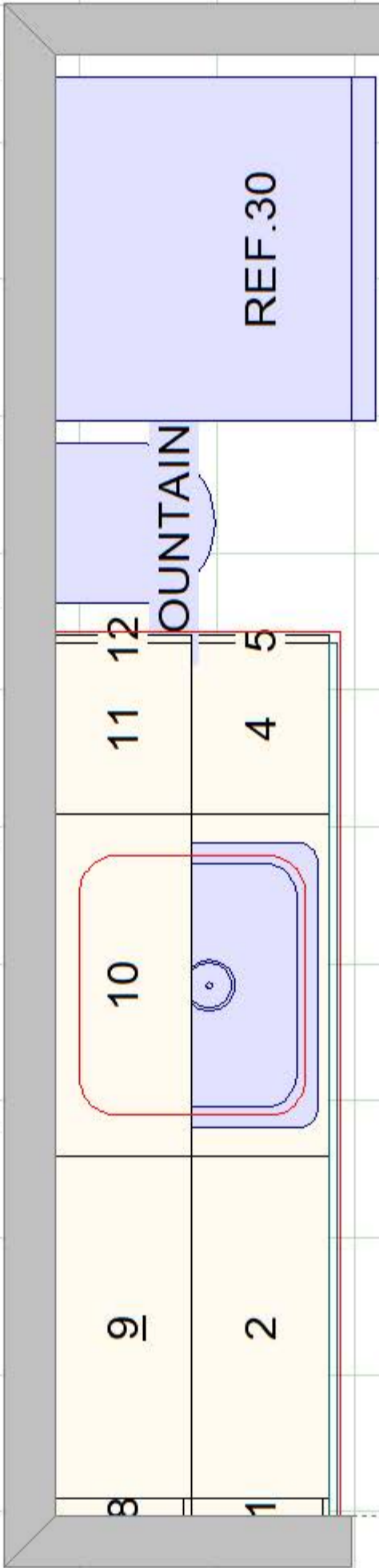
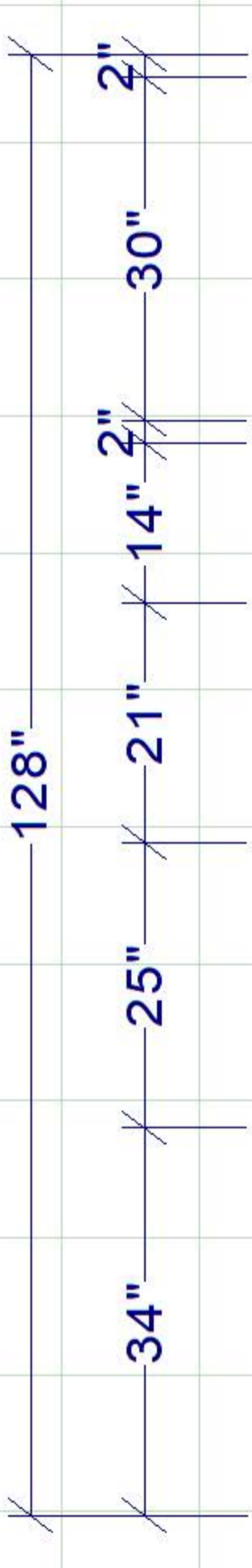

- Legend
- 1: FS330A
 - 2: B30IB
 - 3: SB30IB
 - 4: B3D15IB
 - 5: BEP24
 - 8: FS330A
 - 9: W3015IB
 - 10: W3030IB
 - 11: W1530RIB
 - 12: WEP1230A

128"

W3015IB

W3030IB

W1:WEP1230A

OUNTAIN

B30IB

B3D1BEP24

REF.30

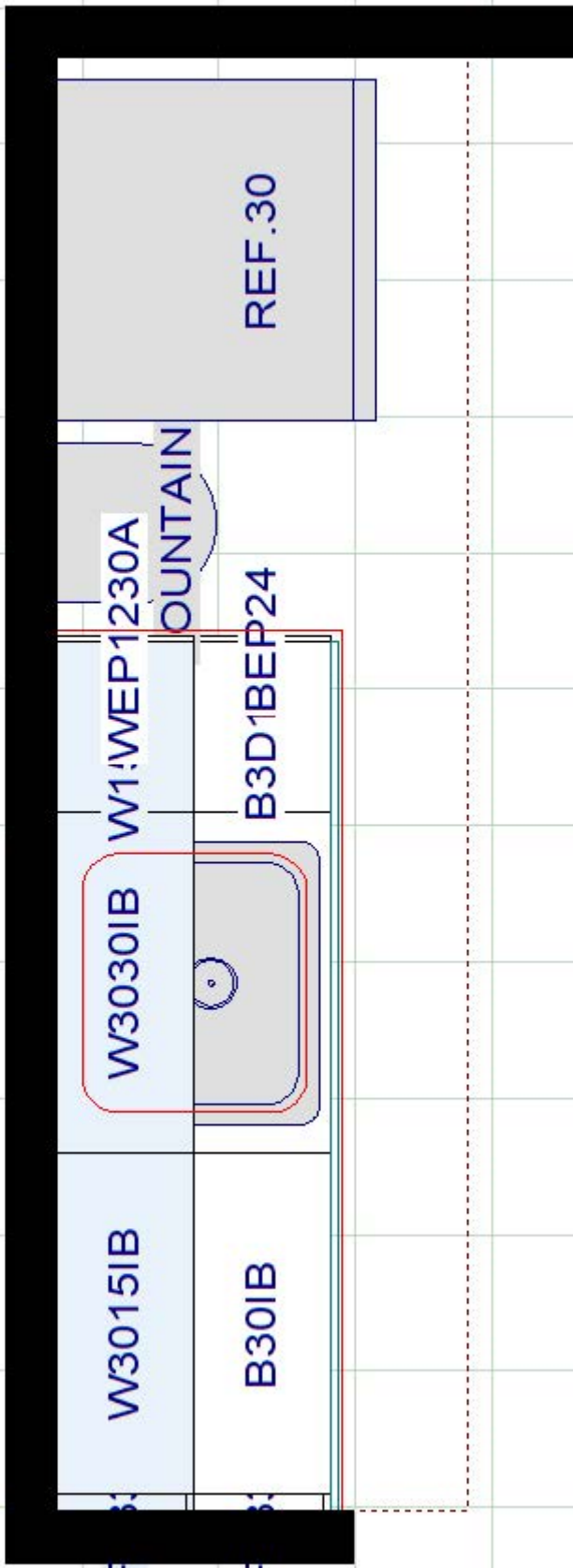

PALMETTO STATION PLANS

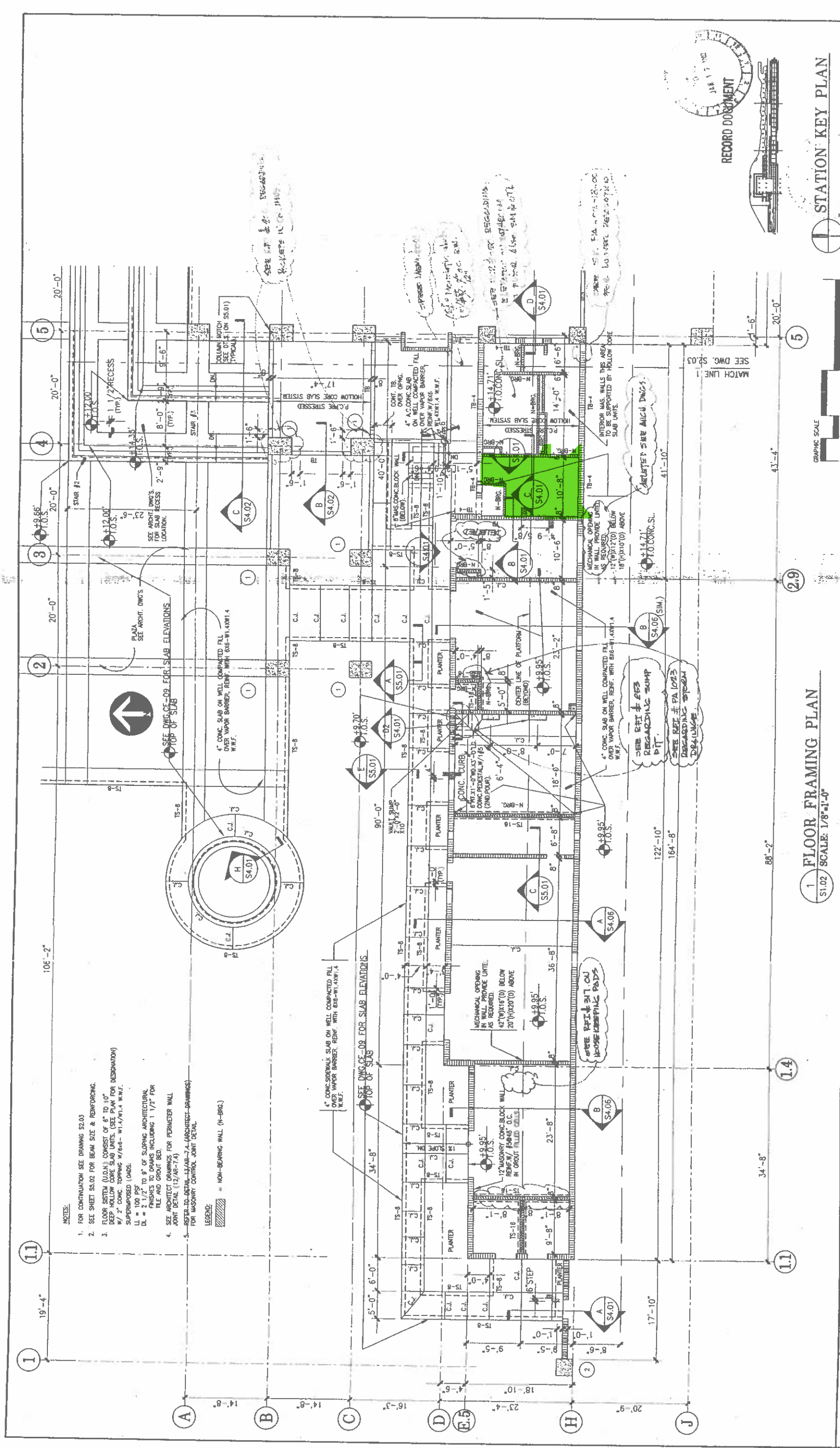

- NOTES:**
1. FOR CONTINUATION SEE DRAWING S2.03
 2. SEE SHEET S5.02 FOR BEAM SIZE & REINFORCING.
 3. FLOOR SYSTEM (U.D.N.) CONSIST OF 8" TO 10" DEEP HOLLOW CORE SLAB UNITS. (SEE PLAN FOR DESIGNATION) W/ 2" CONC. TOPPING W/ 6-6 - W1.4/RT.4 W.W.F. SUPERIMPOSED LOADS.
 LL = 100 PSF
 DL = 2 1/2" TO 9" OF SLOPING ARCHITECTURAL FINISHES TO DOWN TO INCLUDING 1 1/2" FOR TILE AND GROUT BED.
 4. SEE ARCHITECT DRAWINGS FOR PERIMETER WALL JOINT DETAIL (12/24/1-14)
 5. REFER TO DETAIL S2.06-7-A (ARCHITECT DRAWINGS) FOR MASONRY CONTROL JOINT DETAIL.
- LEGEND:**
- ▨ NON-BEARING WALL (N-BRG.)



1 FLOOR FRAMING PLAN
 S1.02 SCALE: 1/8"=1'-0"

METRORAIL EXTENSION to the PALMETTO EXPRESSWAY

STATION

**FLOOR FRAMING PLAN
 ANCILLARY AND SERVICE CORE**

B.D. Designed	Date	01-30-98	APPROVED: E.M.S.	DATE:	01-30-98	SCALE: 1/8"=1'-0"	DRAWING: S2.02-1	SHEET: 67
A.D. Drawn	Date	01-30-98	APPROVED: E.M.S.	DATE:				
E.M.S. Checked	Date	01-30-98	APPROVED: E.M.S.	DATE:				
M.M. Approved	Date	01-30-98	APPROVED: E.M.S.	DATE:				

M E T R O - D A D A
I K A N S I T I











Frederic R. Harris, Inc.
 6625 Miami Lakes Drive East
 Suite 200
 Miami, FL 33114
 (305) 826-0606

**WOLFGANG
 ALVAROZ
 ARCHITECTS**

5960 S.W. 57TH AVE.
 MIAMI, FL 33143
 Tel. (305) 666-5474
 Fax (305) 886-4994
 AA 0002416

EUGENIO M. SANTIAGO, P.E.
 FL. ENG. REC. NO. 19873

ELECTRICAL SYMBOLS:

-  POLE MOUNTED SINGLE LUMINAIRE WITH SEPARATE PULL BOX AT POLE BASE.
-  POLE MOUNTED DUAL LUMINAIRE WITH SEPARATE PULL BOX AT POLE BASE.
-  SINGLE LUMINAIRE POST TOP MOUNTED ON POLE.
-  FLUORESCENT FIXTURE, 2' x 4' AS SPECIFIED CONNECTED TO THE NORMAL POWER.
-  FLUORESCENT FIXTURE, 2' x 4' AS SPECIFIED CONNECTED TO THE EMERGENCY POWER.
-  WALL MOUNTED SECURITY LIGHT FIXTURE UNLESS NOTED OTHERWISE.
-  INGROUND LIGHT FIXTURE LOCATED INSIDE PLANTER.
-  HIGH INTENSITY DISCHARGE OR FLUORESCENT LUMINAIRE AS SPECIFIED, CONNECTED TO NORMAL POWER.
-  HIGH INTENSITY DISCHARGE OR FLUORESCENT LUMINAIRE AS SPECIFIED, CONNECTED TO EMERGENCY POWER.
-  BOLLARD FIXTURE MOUNTED ON PLATFORM AS SPECIFIED, CONNECTED TO NORMAL POWER.
-  BOLLARD FIXTURE MOUNTED ON PLATFORM AS SPECIFIED, CONNECTED TO EMERGENCY POWER.











INTRUSION SYMBOLS:

-  HIGH TEMPERATURE DEVICE
-  EXHAUST FAN MULTIFUNCTION DEVICE



ABBREVIATIONS:

- A AMP
- AF ABOVE FINISHED FLOOR
- ANNUN ANNUNCIATOR
- AWG AMERICAN WIRE GAUGE
- BATT BATTERY
- BS BELL SOUTH
- BRK BREAKER
- BLDG BUILDING
- C, CDT CONDUIT
- CCIV CLOSED CIRCUIT TELEVISION
- CB CIRCUIT BREAKER
- CKT CIRCUIT
- COL COLUMN
- COMM COMMUNICATION
- CONC CONCRETE
- COND CONDUCTOR
- CU COPPER
- CTL CONTROL
- DISC DISCONNECT
- DISTRIB DISTRIBUTION
- DR DOOR
- DWG DRAWING
- ELEC ELECTRICAL
- ELC ELECTRICAL PANEL
- EMERG EMERGENCY FIRE CABINET
- END OF LINE END OF LINE RESISTOR
- EQUR EQUIPMENT
- EMERG TRIP STATION EMERGENCY TRIP STATION
- FIRE & INTRUSION ALARM CONTROL PANEL
- FACP FIRE ALARM CONTROL PANEL
- FL FLUORESCENT
- FPL FLUORIDA POWER & LIGHT
- GND GROUND
- IRRG IRRADIATION
- JUNC JUNCTION
- KA KILO AMPERE
- KVA KILOWATT AMPERE
- LCD LIQUID CRYSTAL DISPLAY
- LP-1 LIGHTING PANEL NAME-CIRCUIT #
- MCB MAIN CIRCUIT BREAKER
- MDC METRO DADE COUNTY
- MFRS MANUFACTURERS
- MH MANHOLE, METAL HALIDE
- NEC NATIONAL ELECTRICAL CODE
- NEMA NATIONAL ELECTRICAL MANUFACTURERS ASSOCIATION
- NFPA NATIONAL FIRE PROTECTION ASSOCIATION
- NEUTRAL NEUTRAL
- N NUMBER
- P POLE
- PB PULL BOX
- PH PHASE
- PWR POWER
- RECP RECEPTACLE
- RM ROOM
- SCA SHORT CIRCUIT AMPERE
- SCH SCHEDULE
- SYS SYSTEM
- SWBRD SWITCHBOARD
- TELE TELEPHONE
- TEMP TEMPERATURE
- TVSS TRANSIENT VOLTAGE SURGE SUPPRESSION
- TYP TYPICAL
- SHIELDED PAIR SHIELDED PAIR
- TSP TYPICAL
- UL UNDERWRITERS LABORATORIES
- UPS UNINTERRUPTIBLE POWER SUPPLY
- UNO UNLESS NOTED OTHERWISE
- VMS VARIABLE MESSAGE SIGN

FIRE ALARM SYMBOLS:

-  INDIVIDUAL ADDRESSABLE MODULE. #2190-9172
-  IONIZATION SMOKE DETECTOR FOR FIRE SUPPRESSION SYSTEM, KIDDE MODEL #CPD-7051
-  PHOTOELECTRIC SMOKE DETECTOR FOR FIRE SUPPRESSION SYSTEM, KIDDE MODEL #PSD-7155
-  IONIZATION SMOKE DETECTOR #4098-9716, 4098-9784 BASE
-  SMOKE DETECTOR MOUNTED TO DUCT SYSTEM. #4098-9716, 4098-9706 HOUSING.
-  THERMAL RATE-OF-RISE AND FIXED TEMPERATURE DETECTOR #4098-9408, 4098-9784 BASE.
-  FIRE ALARM SYSTEM MANUAL PULL STATION. MOUNTED 48" AFF. #2099-9795
-  ADD STROBE LIGHT 80" AFF TO THE BOTTOM OF THE DEVICE OR 6" BELOW CEILING WHICHEVER IS LOWER. #4903-9219
-  LOW INTENSITY ADD STROBE LIGHT 80" AFF OR 6" BELOW CEILING WHICHEVER IS LOWER. #4903-9217
-  FIRE ALARM SYSTEM ANNUNCIATOR PANEL. #4603
-  FIRE & INTRUSION ALARM CONTROL PANEL. SIMPLEX 4100-8201 EQUIPMENT.

CONDUCTORS AND RACEWAY

-  RACEWAY CONCEALED IN FLOOR SLAB OR UNDERGROUND (SHOWN HEAVY)
-  RACEWAY CONCEALED IN CEILING OR WALL
-  RACEWAY EXPOSED

GENERAL NOTES:

1. ALL SWITCH OUTLETS SHALL BE MOUNTED 42" AFF, UNLESS NOTED OTHERWISE.
2. "OS" NEXT TO LIGHT FIXTURE CATALOG NUMBER IS ONLY APPLICABLE FOR THOSE FIXTURE CONNECTED TO THE EMERGENCY POWER SOURCE. SEE SCHEDULE OF LIGHTING FIXTURES ON DWG. EEB.4.
3. COORDINATE EXACT LOCATION OF ALL LIGHT FIXTURES WITH THE ARCHITECT.
4. FOR ADDITIONAL ELECTRICAL SYMBOLS, ABBREVIATIONS AND GENERAL NOTES SEE MEDIA REFERENCE DRAWINGS INCLUDED IN CONTRACT DOCUMENTS.
5. ALL FIRE ALARM AND COMMUNICATION SYSTEM SHALL BE POWER LIMITED.
6. ALL FIRE ALARM SYSTEM CATALOG NUMBERS ARE BY SIMPLEX MANUFACTURER OR APPROVED EQUIVALENT, UNO.
7. MINIMUM SIZE CONDUIT SHALL BE 3/4".
8. EOLR TO HAVE VALVE OF 10K OHM, FOR EACH CIRCUIT, AS INDICATED.
9. CABLE TYPE SHALL BE POWER LIMITED FIRE PROTECTED SIGNALING CIRCUIT TYPE PPL OR APPROVED EQUIVALENT.
10. THE MOUNTING OF AUDIO AND VISUAL DEVICE SHALL NOT EXCEED 80" AFF.
11. THE ALARM SYSTEM SHALL BE POWER LIMITED.

SEE PPT # 131 & #182.
REGARDING RACEWAY ADDRESS SYSTEM

SEE PPT # 211
REGARDING THE FIRE ALARM SYSTEM.

<p>IC* Designed 8-18-97 Date</p> <p>SC Drawn 8-18-97 Date</p> <p>IR Checked 6-2-98 Date</p> <p>TR Approved 6-2-98 Date</p>	<p>RF No. 1 THROUGH No. 204 ISSUED FOR CONSTRUCTION NO CHANGES PERMITTED</p> <p>Revisions No. Date By App. Date</p>	<p>METRO-DADE T K A N S I T I</p>	<p>Frederic R. Harris, Inc. 6625 Miami Lakes Drive East Suite 200 Miami, FL 33014 (305) 826-0606</p>	<p>Designers & Engineers of Mechanical & Electrical Systems INDEPENDENT MECHANICAL DESIGNERS & CONSULTANTS INC. 4141 N.E. SECOND AVENUE - SUITE 101 MIAMI FLORIDA 33137 • 305/573-8295</p>	<p>DATE: 6-2-98</p> <p>APPROVED: TR</p> <p>SCALE: NONE</p> <p>DRAWING: EEO.0</p> <p>SHEET: 136</p>
<p>STATION</p> <p>ELECTRICAL SYMBOLS, ABBREVIATIONS AND GENERAL NOTES</p>		<p>METRO RAIL EXTENSION to the PALMETTO EXPRESSWAY and MULTI-MODAL FACILITY</p>			

