



DEPARTMENT OF REGULATORY AND ECONOMIC RESOURCES (RER)
BOARD AND CODE ADMINISTRATION DIVISION

MIAMI-DADE COUNTY
PRODUCT CONTROL SECTION

11805 SW 26 Street, Room 208
T (786) 315-2590 F (786) 315-2599

NOTICE OF ACCEPTANCE (NOA)

www.miamidade.gov/economy

ES Windows, LLC
3550 NW 49th Street
Miami, FL 33142

SCOPE:

This NOA is being issued under the applicable rules and regulations governing the use of construction materials. The documentation submitted has been reviewed and accepted by Miami-Dade County RER - Product Control Section to be used in Miami Dade County and other areas where allowed by the Authority Having Jurisdiction (AHJ).

This NOA shall not be valid after the expiration date stated below. The Miami-Dade County Product Control Section (In Miami Dade County) and/or the AHJ (in areas other than Miami Dade County) reserve the right to have this product or material tested for quality assurance purposes. If this product or material fails to perform in the accepted manner, the manufacturer will incur the expense of such testing and the AHJ may immediately revoke, modify, or suspend the use of such product or material within their jurisdiction. RER reserves the right to revoke this acceptance, if it is determined by Miami-Dade County Product Control Section that this product or material fails to meet the requirements of the applicable building code.

This product is approved as described herein, and has been designed to comply with the Florida Building Code, including the High Velocity Hurricane Zone.

DESCRIPTION: Series "EL300" Aluminum Outswing Door - L.M.I.

APPROVAL DOCUMENT: Drawing No. W17-59, titled "ES-EL300 Aluminum Outswing Door (L.M.I.)", sheets 1 through 12 of 12, dated 06/20/17, with revision A dated 07/21/17, prepared by Al-Farooq Corporation, signed and sealed by Javad Ahmad, P.E., bearing the Miami-Dade County Product Control Approval stamp with the Notice of Acceptance number and approval date by the Miami-Dade County Product Control Section.

MISSILE IMPACT RATING: Large and Small Missile Impact Resistant

LABELING: Each unit shall bear a permanent label with the manufacturer's name or logo, **Baranquilla, Columbia, S.A.**, series, and the following statement: "Miami-Dade County Product Control Approved", unless otherwise noted herein.

RENEWAL of this NOA shall be considered after a renewal application has been filed and there has been no change in the applicable building code negatively affecting the performance of this product.

TERMINATION of this NOA will occur after the expiration date or if there has been a revision or change in the materials, use, and/or manufacture of the product or process. Misuse of this NOA as an endorsement of any product, for sales, advertising or any other purposes shall automatically terminate this NOA. Failure to comply with any section of this NOA shall be cause for termination and removal of NOA.

ADVERTISEMENT: The NOA number preceded by the words Miami-Dade County, Florida, and followed by the expiration date may be displayed in advertising literature. If any portion of the NOA is displayed, then it shall be done in its entirety.

INSPECTION: A copy of this entire NOA shall be provided to the user by the manufacturer or its distributors and shall be available for inspection at the job site at the request of the Building Official.

This NOA consists of this page 1 and evidence pages E-1 and E-2, as well as approval document mentioned above.

The submitted documentation was reviewed by **Jorge M. Plasencia, P.E.**



J 12/28/2017

NOA No. 16-0617.03
Expiration Date: January 04, 2023
Approval Date: January 04, 2018
Page 1

NOTICE OF ACCEPTANCE: EVIDENCE SUBMITTED

1. NEW EVIDENCE SUBMITTED

A. DRAWINGS

1. Manufacturer's die drawings and sections.
2. Drawing No. **W17-59**, titled "ES-EL300 Aluminum Outswing Door (L.M.I.)", sheets 1 through 12 of 12, dated 06/20/17, with revision A dated 07/21/17, prepared by Al-Farooq Corporation, signed and sealed by Javad Ahmad, P.E.

B. TESTS

1. Test reports on:
 - 1) Air Infiltration Test, per FBC, TAS 202-94
 - 2) Uniform Static Air Pressure Test, Loading per FBC, TAS 202-94
 - 3) Water Resistance Test, per FBC, TAS 202-94
 - 4) Forced Entry Test, per FBC, and TAS 202-94
 - 6) Large Missile Impact Test per FBC, TAS 201-94
 - 7) Cyclic Wind Pressure Loading per FBC, TAS 203-94

along with marked-up drawings and installation diagram of an aluminum outswing door, prepared by Blackwater Testing, Inc., Test Report No. **BT-ESW-17-008**, dated 06/15/17, signed and sealed by Constantin Bortes, P.E. with Letter of Clarification issued on 08/03/17, signed and sealed by Constantin Bortes, P.E.

C. CALCULATIONS

1. Anchor verification calculations and structural analysis, complying with **FBC-5th Edition (2014) and FBC-6th Edition (2017)**, dated 06/19/17, prepared by Al-Farooq Corporation, signed and sealed by Javad Ahmad, P.E.
2. Glazing complies with **ASTM E1300-09**.

D. QUALITY ASSURANCE

1. Miami-Dade Department of Regulatory and Economic Resources (RER)

E. MATERIAL CERTIFICATIONS

1. Notice of Acceptance No. **16-1117.01** issued to **Kuraray America, Inc.** for their "**Trosifol® Ultraclear, Clear and Color PVB Glass Interlayers**" dated 01/19/17, expiring on 07/08/19.
2. Notice of Acceptance No. **14-0916.11** issued to **Kuraray America, Inc.** for their "**Sentry Glas® (Clear and White) Glass Interlayer**" dated 06/25/15, expiring on 07/04/18.
3. Notice of Acceptance No. **17-0712.05** issued to **Eastman Chemical Co. (MA)** for their "**Saflex Clear and Color Glass Interlayers**" dated 09/07/17, expiring on 05/21/21.
4. Notice of Acceptance No. **17-0712.03** issued to **Eastman Chemical Co. (MA)** for their "**Saflex CP – Saflex and Saflex HP Composite Glass Interlayers with PET Core**" dated 09/07/17, expiring on 12/11/18.



Jorge M. Plasencia, P.E.
Product Control Unit Supervisor
NOA No. 16-0617.03
Expiration Date: January 04, 2023
Approval Date: January 04, 2018

NOTICE OF ACCEPTANCE: EVIDENCE SUBMITTED

F. STATEMENTS

1. Statement letter of conformance, to **FBC-5th Edition (2014)** and **FBC-6th Edition (2017)** and of no financial interest dated 07/25/17, issued by Al-Farooq Corporation, signed and sealed by Javad Ahmad, P.E.
2. Distributor Agreement, signed by Carlos Garcia and by Evelyn Daes.
3. Laboratory compliance statement for Test Report No. **BT-ESW-17-008**, issued by Blackwater Testing, Inc., dated 06/15/17, signed and sealed by Dennis Duffy, CEO.
4. Proposal No. **16-1477** issued by the Product Control Section, dated 11/23/16, signed by Ishaq Chanda, P.E.

G. OTHERS

1. None.

Jorge M. Plasencia, P.E.
Product Control Unit Supervisor
NOA No. 16-0617.03
Expiration Date: January 04, 2023
Approval Date: January 04, 2018

THESE DOORS ARE RATED FOR LARGE & SMALL MISSILE IMPACT. SHUTTERS ARE NOT REQUIRED.

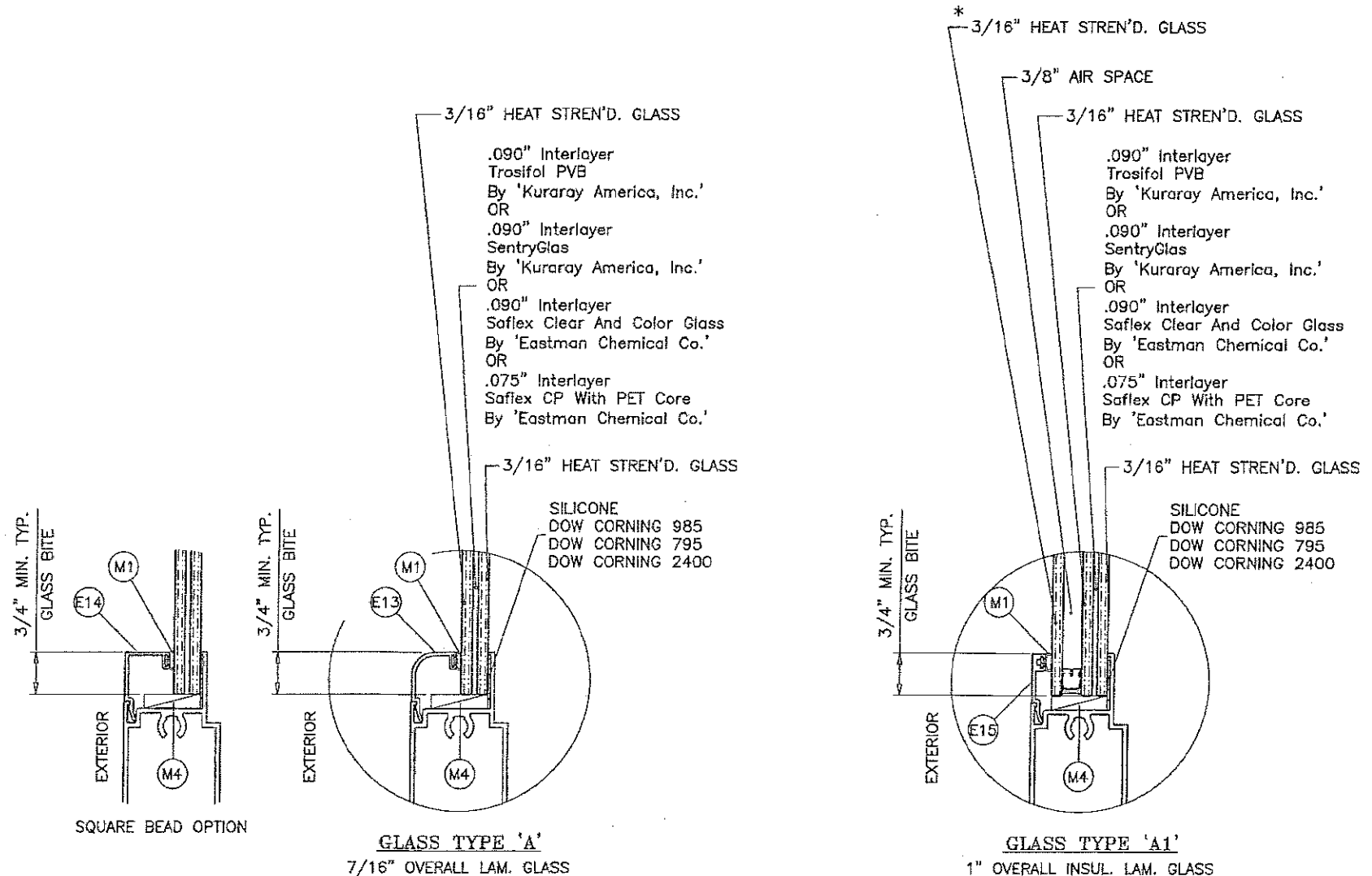

**ES-EL300
ALUMINUM OUTSWING ENTRANCE DOOR**

APPROVAL APPLIES TO SINGLE (X) AND DOUBLE (XX) LEAF DOORS WITH OR WITHOUT SIDELITES. SIDE LITES CAN BE ON ONE OR BOTH SIDES OF DOOR.

DOORS APPROVED FOR INSTALLATIONS WHERE WATER INFILTRATION RESISTANCE IS REQUIRED.

THIS PRODUCT HAS BEEN DESIGNED AND TESTED TO COMPLY WITH THE REQUIREMENTS OF THE 2014 (5TH EDITION)/2017 (6TH EDITION) FLORIDA BUILDING CODE INCLUDING HIGH VELOCITY HURRICANE ZONE (HVHZ).

1BY OR 2BY WOOD BUCKS & BUCK FASTENERS BY OTHERS, MUST BE DESIGNED AND INSTALLED ADEQUATELY TO TRANSFER APPLIED PRODUCT LOADS TO THE BUILDING STRUCTURE.

ANCHORS SHALL BE CORROSION RESISTANT, SPACED AS SHOWN ON DETAILS AND INSTALLED PER MANUF'S INSTRUCTIONS. SPECIFIED EMBEDMENT TO BASE MATERIAL SHALL BE BEYOND WALL DRESSING OR STUCCO.

A LOAD DURATION INCREASE IS USED IN DESIGN OF ANCHORS INTO WOOD ONLY. ALL SHIMS TO BE HIGH IMPACT, NON-METALLIC AND NON-COMPRESSIBLE.

MATERIALS INCLUDING BUT NOT LIMITED TO STEEL/METAL SCREWS, THAT COME INTO CONTACT WITH OTHER DISSIMILAR MATERIALS SHALL MEET THE REQUIREMENTS OF THE 2014/2017 FLORIDA BLDG. CODE & ADOPTED STANDARDS.

THIS PRODUCT APPROVAL IS GENERIC AND DOES NOT PROVIDE INFORMATION FOR A SITE SPECIFIC PROJECT, I.E. LIFE SAFETY OF THIS PRODUCT, ADEQUACY OF STRUCTURE RECEIVING THIS PRODUCT AND SEALING AROUND OPENING FOR WATER INFILTRATION RESISTANCE ETC. CONDITIONS NOT SHOWN IN THIS DRAWING ARE TO BE ANALYZED SEPARATELY, AND TO BE REVIEWED BY BUILDING OFFICIAL.

INSTRUCTIONS:

USE CHARTS AS FOLLOWS.

- STEP 1** DETERMINE DESIGN WIND LOAD REQUIREMENT BASED ON WIND VELOCITY, BLDG. HEIGHT, WIND ZONE USING APPLICABLE ASCE 7 STANDARD.
- STEP 2** FOR SINGLE (X) AND DOUBLE (XX) DOOR CAPACITIES SEE SHEET 2.
- STEP 3** FOR SIDELITE PANEL (O) CAPACITY SEE SHEET 3.
- STEP 4** FOR SIDELITE COMBINATION WITH DOOR SEE MULLION CAPACITY CHART ON SHEET 4.
- STEP 5** THE LOWEST VALUE RESULTING FROM STEPS 2, 3 AND 4 SHALL APPLY TO ENTIRE SYSTEM.

GLAZING OPTIONS

* NOTE:
EXTERIOR LITE OF GLASS TYPE 'A1' TO BE TEMPERED FOR INSTALLATIONS ABOVE 30 FT. OF GRADE.

3/8" AIR SPACE CONSISTING OF:
SPACER:
'HELIMA' LOW PROFILE ALUMINUM SPACER BY 'LINGERMANN GMBH' AROUND THE PERIMETER OF THE GLASS.
PERIMETER SEALANT:
SILICONE
DOW CORNING 791
GE 2000

PRODUCT REVISED
as complying with the Florida Building Code
NOA-No. **16-0617.03**

Expiration Date **01/04/2023**

By *[Signature]*
Miami-Dade Product Control

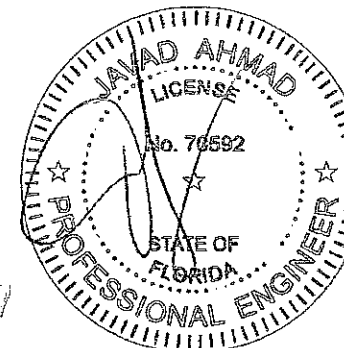

LIC 27 2017

afC
AL-FAROOQ CORPORATION
ENGINEERS & PRODUCT DEVELOPMENT
9360 SUNSET DRIVE, SUITE 220
MIAMI, FLORIDA 33173
TEL. (305) 264-8100 FAX. (305) 262-6978
(C.A.N. 3538)

ES-EL300 ALUMINUM OUTSWING DOOR (L.M.I.)
E.S. WINDOWS, LLC
3550 N.W. 49 STREET
MIAMI, FL. 33142
TEL. (305) 638-5151 FAX. (305) 638-5158

no.	date	by	description	REV. PER. COMMENTS
A	07.21.17			

date: 06-20-17
scale: 3/8" = 1"
dr. by: FARIQ
chk. by:

drawing no. **W17-59**
sheet 1 of 12

COMP-ANL\W17-59ES

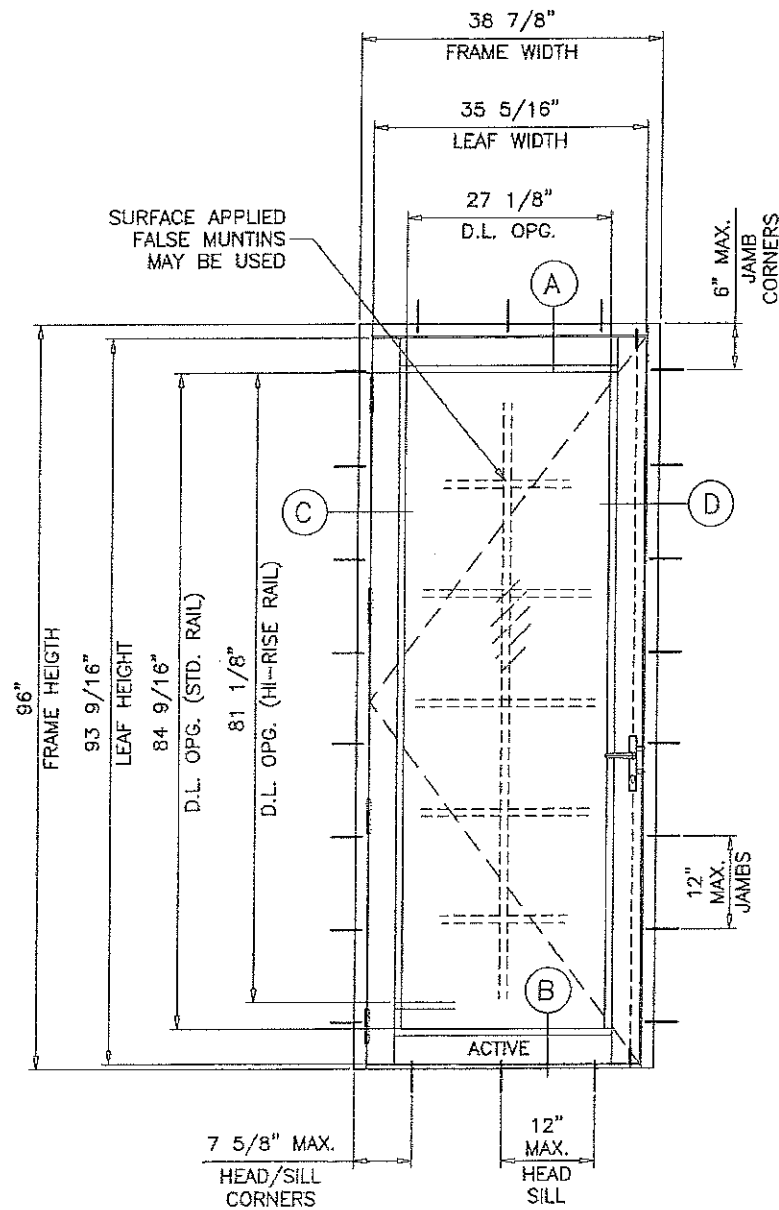

STD. SILL
TYPICAL ELEVATION
(X)

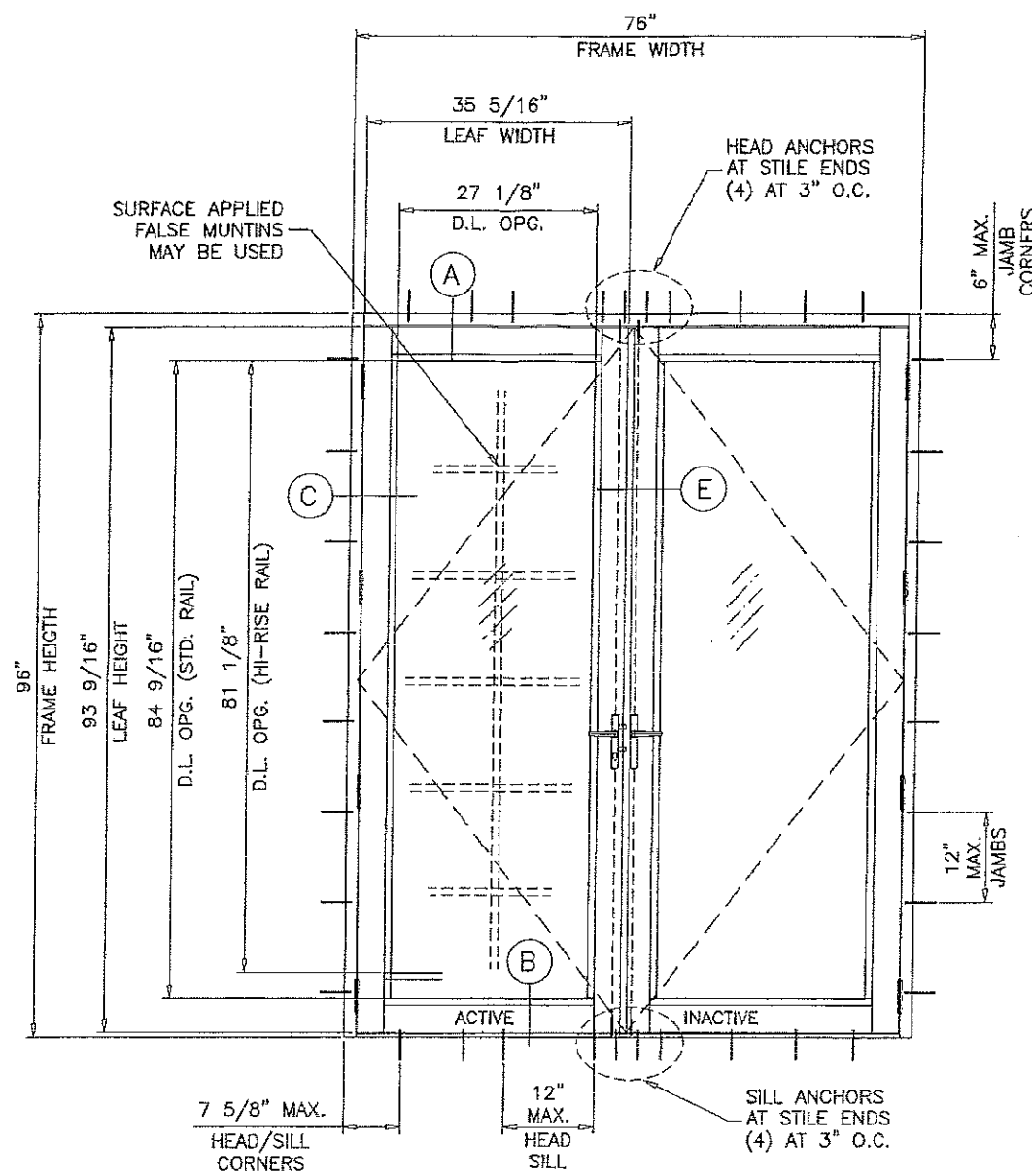

STD. SILL
TYPICAL ELEVATION
(XX)

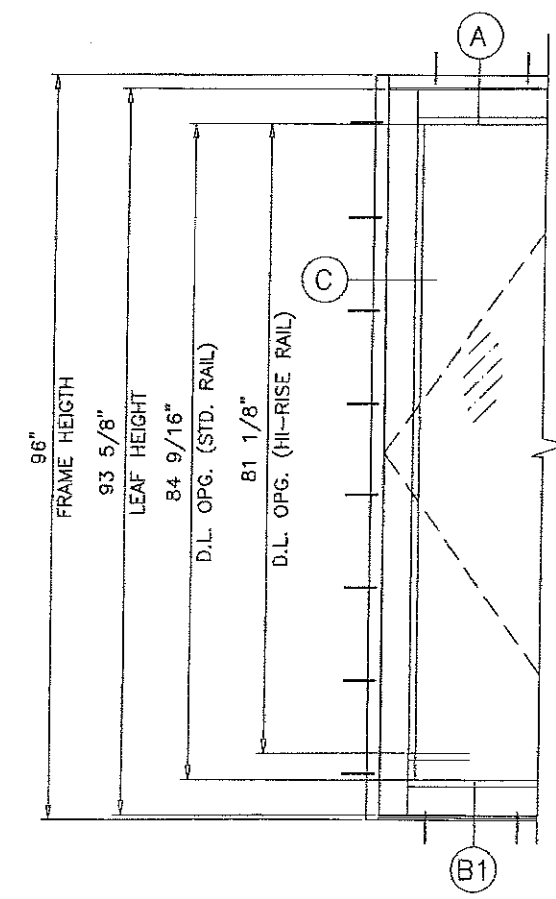

SINGLE OR DOUBLE DOORS
WITH ADA SILL

SINGLE DOORS LOAD CAPACITY - PSF						
FRAME		LEAF		THRESHOLD TYPES	EXT.(+)	INT.(-)
WIDTH	HEIGHT	WIDTH	HEIGHT			
38-7/8"	96"	35-5/16"	93-9/16"	STD.	80.0	80.0
38-7/8"	96"	35-5/16"	93-5/8"	ADA	80.0	80.0

DOUBLE DOORS LOAD CAPACITY - PSF						
FRAME		LEAF		THRESHOLD TYPES	EXT.(+)	INT.(-)
WIDTH	HEIGHT	WIDTH	HEIGHT			
76"	96"	35-5/16"	93-9/16"	STD.	80.0	80.0
76"	96"	35-5/16"	93-5/8"	ADA	80.0	80.0

PRODUCT REVISED
as complying with the Florida
Building Code
NOA-No. **16-0617.03**

Expiration Date **01/04/2023**

By *[Signature]*
Miami-Dade Product Control

NOTE:
GLASS CAPACITIES ON THIS SHEET ARE
BASED ON ASTM E1300-09 (3 SEC. GUSTS)
AND FLORIDA BUILDING COMMISSION
DECLARATORY STATEMENT DCA05-DEC-219

GLASS D.L.O. FORMULAE:
D.L.O. WIDTH = FRAME WIDTH - 11.750" (X DOORS)
= (FRAME WIDTH - 21.750")/2 (XX DOORS)
D.L.O. HEIGHT = FRAME HEIGHT - 11.438" (STD. BOT. RAIL)
= FRAME HEIGHT - 14.875" (HI-RISE BOT. RAIL)

LIC 27 207

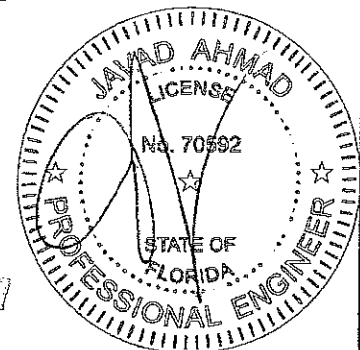

af c
AL-FAROOQ CORPORATION
ENGINEERS & PRODUCT DEVELOPMENT
9360 SUNSET DRIVE, SUITE 220
MIAMI, FLORIDA 33173 (C.A.N. 3538)
TEL. (305) 264-8100 FAX. (305) 262-6978
COMP-ANL\W17-59ES

ES-EL300 ALUMINUM OUTSWING DOOR (L.M.I.)
E.S. WINDOWS, LLC
3550 N.W. 49 STREET
MIAMI, FL. 33142
TEL. (305) 638-5151 FAX. (305) 638-5158

revisions:	NO	DATE	DESCRIPTION
	A	07/21/17	REV. PER PER COMMENTS

date: 06-20-17
scale: 1/2"=1'-0"
dr. by: TARIQ
chk. by:

drawing no.
W17-59
sheet 2 of 12

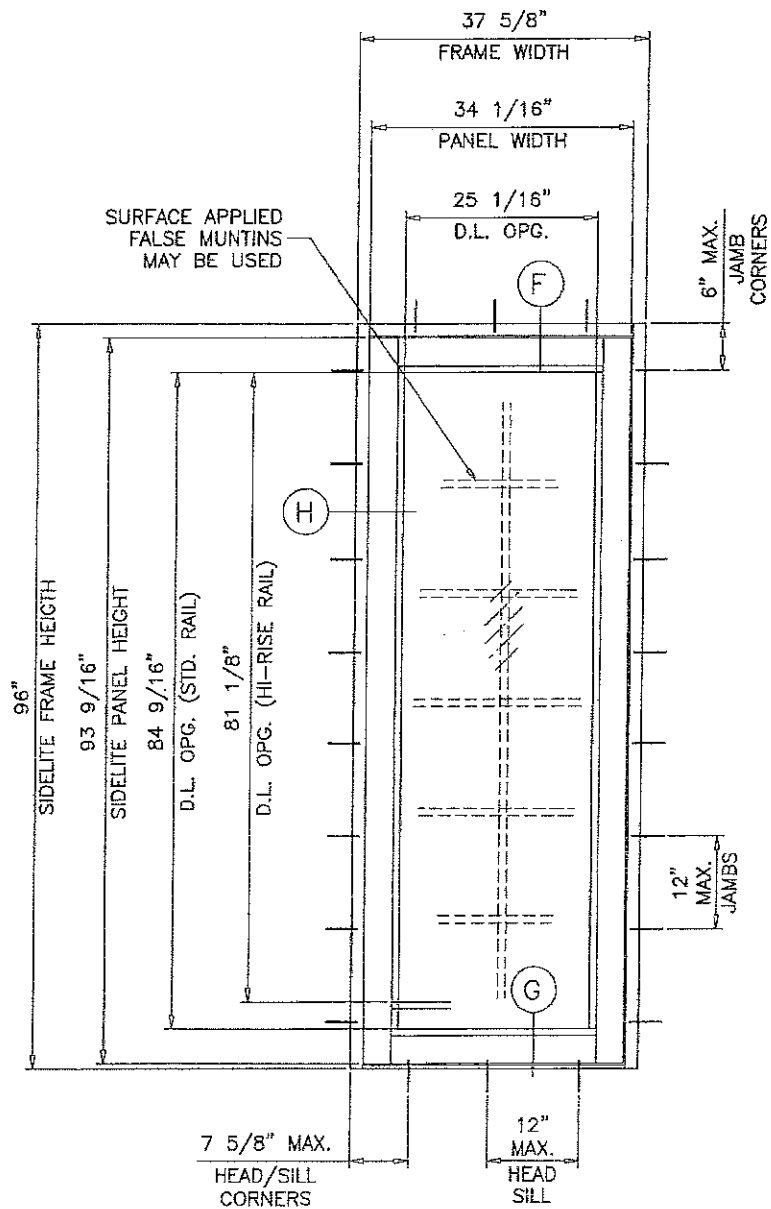

TYPICAL ELEVATION
(O)

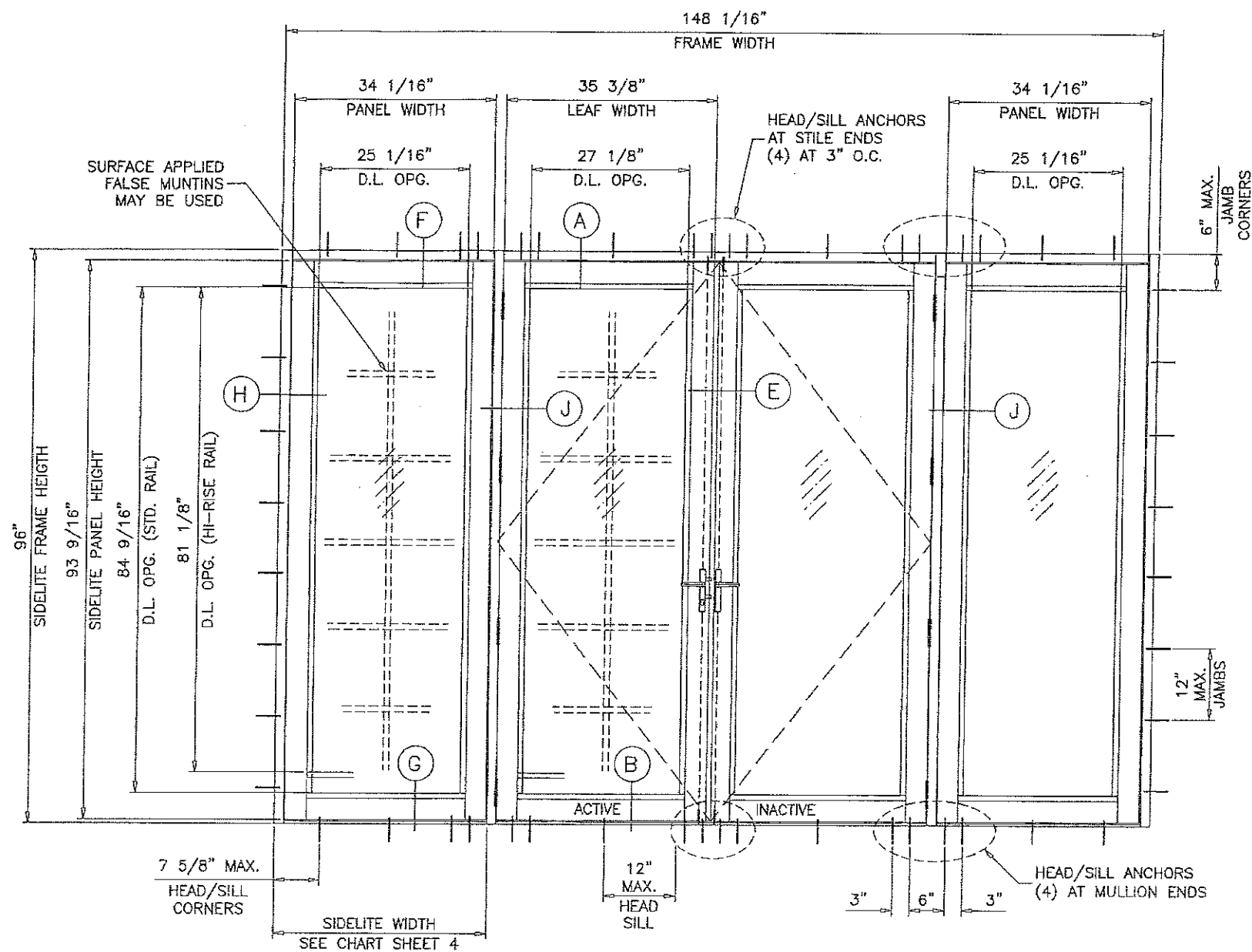

TYPICAL ELEVATION
(O-XX-O)

NOTE:
THE FRAME AREA OF ALTERNATE SIZE MUST NOT EXCEED TESTED FRAME AREA = 98.7 SQ. FT.

SIDELITE LOAD CAPACITY - PSF OR STAND ALONE STATIONARY PANEL (O)						
FRAME		PANEL		THRESHOLD TYPES	EXT.(+)	INT.(-)
WIDTH	HEIGHT	WIDTH	HEIGHT			
37-5/8"	96"	34-1/16"	93-9/16"	STD.	80.0	80.0
37-5/8"	96"	34-1/16"	93-5/8"	ADA	80.0	80.0
43-5/8"	82"	40-1/16"	79-9/16"	STD.	80.0	80.0
43-5/8"	82"	40-1/16"	79-5/8"	ADA	80.0	80.0

D.L.O. HEIGHT (SIDELITE) = FRAME HEIGHT - 11.438" (STD. BOT. RAIL)
 = FRAME HEIGHT - 14.875" (HI-RISE BOT. RAIL)
 D.L.O. WIDTH (SIDE LITE) = FRAME WIDTH - 12.563"

PRODUCT REVISED
 as complying with the Florida
 Building Code
 NOA-No. **16-0617.03**
 Expiration Date **01/04/2023**
 By *[Signature]*
 Miami-Dade Product Control

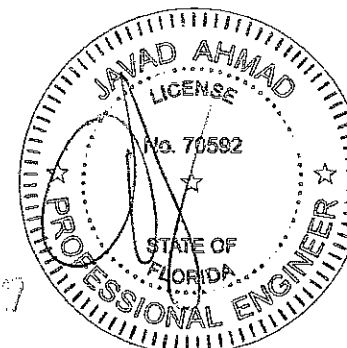

LEC 27 2017

afc
AL-FAROOQ CORPORATION
 ENGINEERS & PRODUCT DEVELOPMENT
 9360 SUNSET DRIVE, SUITE 220 (C.A.N. 3538)
 MIAMI, FLORIDA 33173
 TEL (305) 264-8100 FAX (305) 262-6978
 COMP-ANL\W17-59ES

ES-EL300 ALUMINUM OUTSWING DOOR (L.M.I.)
E.S. WINDOWS, LLC
 3550 N.W. 49 STREET
 MIAMI, FL. 33142
 TEL (305) 638-5151 FAX (305) 638-5158

revisions:	no.	date	BY	DESCRIPTION
	A	07.21.17		NO CHANGE THIS SHEET

date: 06-20-17
 scale: 1/2" = 1'-0"
 dr. by: TARIQ
 chk. by:
 drawing no. **W17-59**
 sheet 3 of 12

DESIGN LOAD CAPACITY - PSF DOOR TO SIDELITE OR DOOR TO DOOR MULLION			
SIDELITE WIDTH INCHES	FRAME HEIGHT INCHES	UNREINFORCED	REINFORCED
		EXT.(+)/INT.(-)	EXT.(+)/INT.(-)
18	82	75.7	80.0
24		68.4	80.0
30		62.4	80.0
36		57.3	80.0
42		53.0	74.5
18	84	71.4	80.0
24		64.4	80.0
30		58.8	80.0
36		54.0	75.9
18	90	58.0	80.0
24		52.4	73.7
30		47.8	67.2
36		43.9	61.7
18	96	47.8	67.2
24		43.2	60.7
30		39.4	55.3
36		36.2	50.9

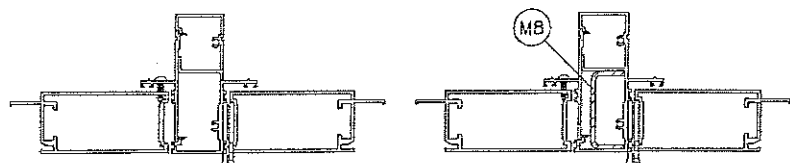

UNREINFORCED REINFORCED

DOOR TO SIDELITE MULLION
DOOR TO DOOR MULLION

NOTE:
FOR DOORS CAPACITY SEE SHEET 2
FOR SIDELITE CAPACITIES SEE SHEET 3.
FOR SIDELITE MULLION CAPACITY SEE CHART ABOVE
LOWER VALUES FROM DOORS, SIDELITE, DOOR/SIDELITE
OR DOOR/DOOR MULLION CHART WILL APPLY TO ENTIRE SYSTEM.

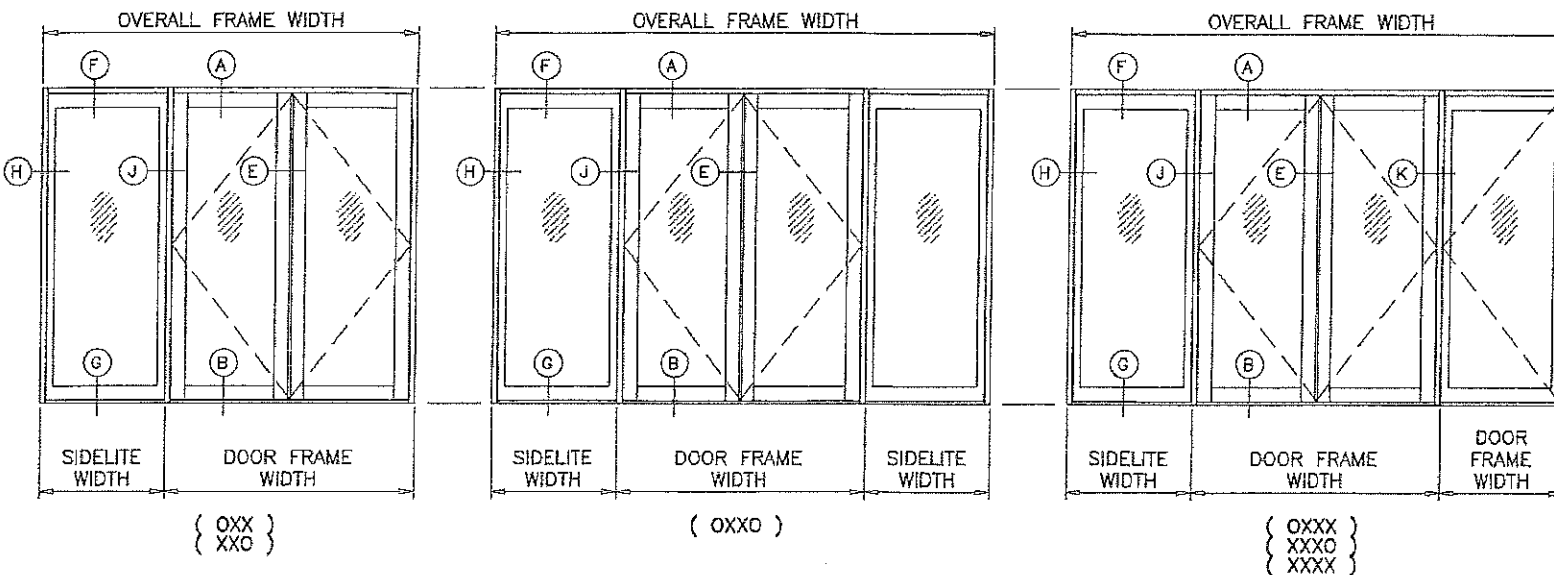
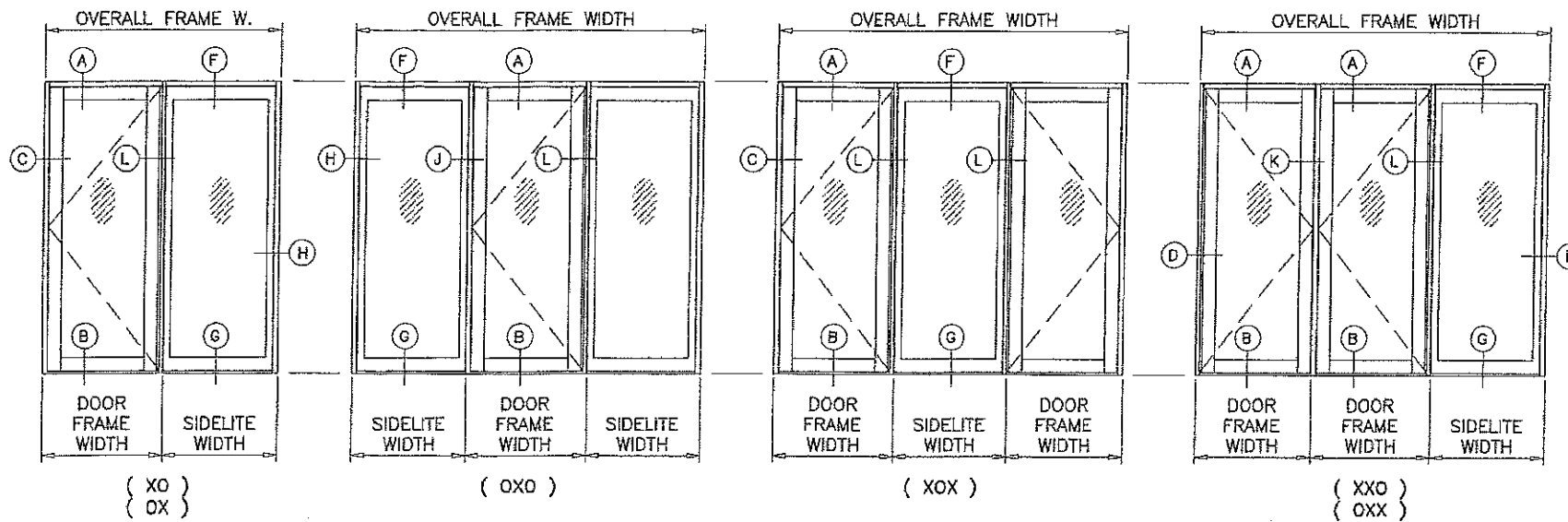

APPROVED CONFIGURATIONS

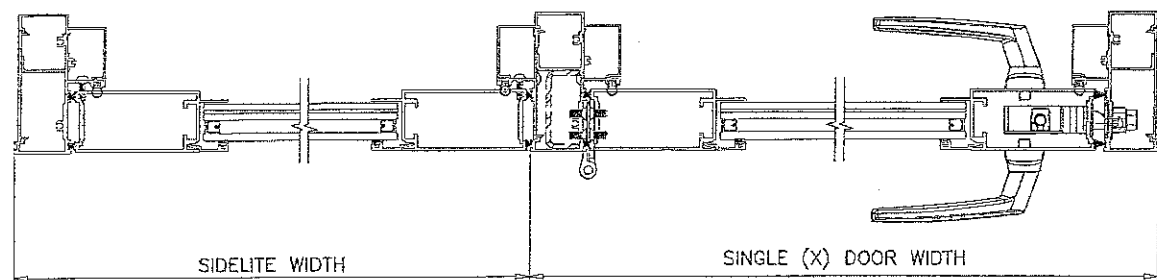

SIDELITE WIDTH SINGLE (X) DOOR WIDTH

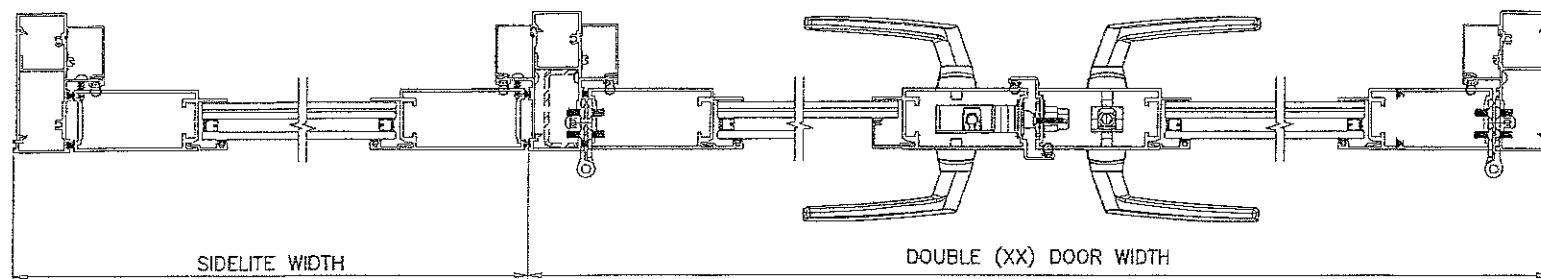

SIDELITE WIDTH DOUBLE (XX) DOOR WIDTH

PRODUCT REVISED
as complying with the Florida
Building Code
NOA-No. **16-0617.03**

Expiration Date **01/04/2023**

By 
Miami-Dade Product Control

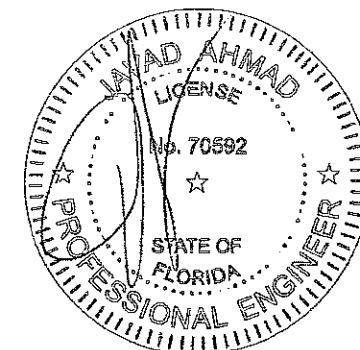

DEC 27 2017

AL-FAROQ CORPORATION
ENGINEERS & PRODUCT DEVELOPMENT
9360 SUNSET DRIVE, SUITE 220
MIAMI, FLORIDA 33173
TEL. (305) 264-8100 FAX. (305) 262-6978
C.A.N. 9538

ES-EL300 ALUMINUM OUTSWING DOOR (L.M.I.)
E.S. WINDOWS, LLC
3550 N.W. 49 STREET
MIAMI, FL 33142
TEL. (305) 638-5151 FAX. (305) 638-5158

revisions:	no.	date	by	description
	A	07.21.17	REV. PER. RER COMMENTS	
date:	06-20-17			
scale:	1/2"=1'-0"			
dr. by:	TARIQ			
chk. by:				
drawing no.	W17-59			
sheet	4 of 12			

COMP-ANL W17-59ES

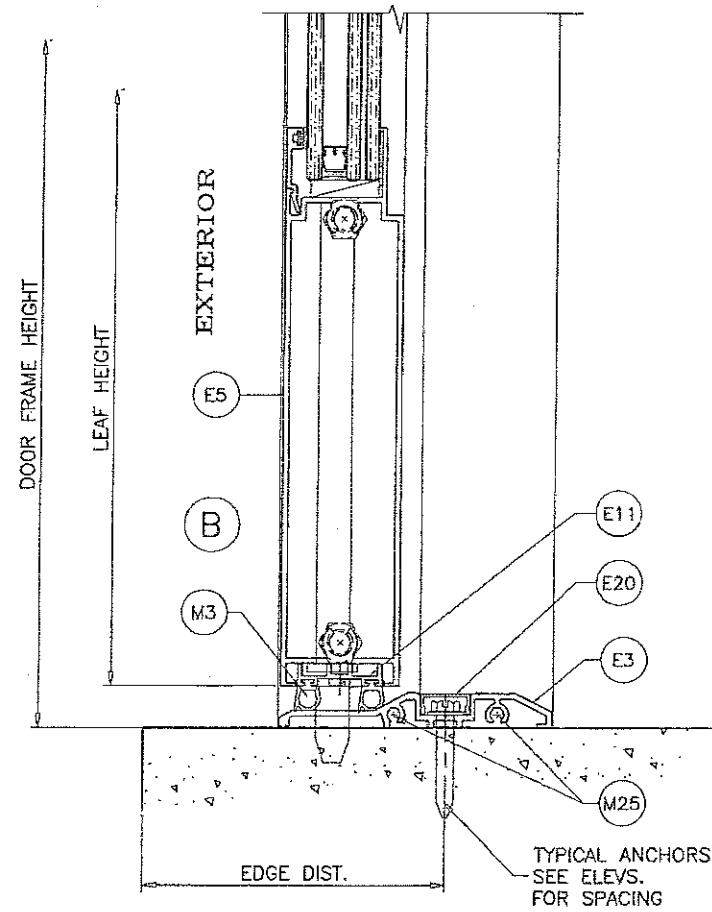
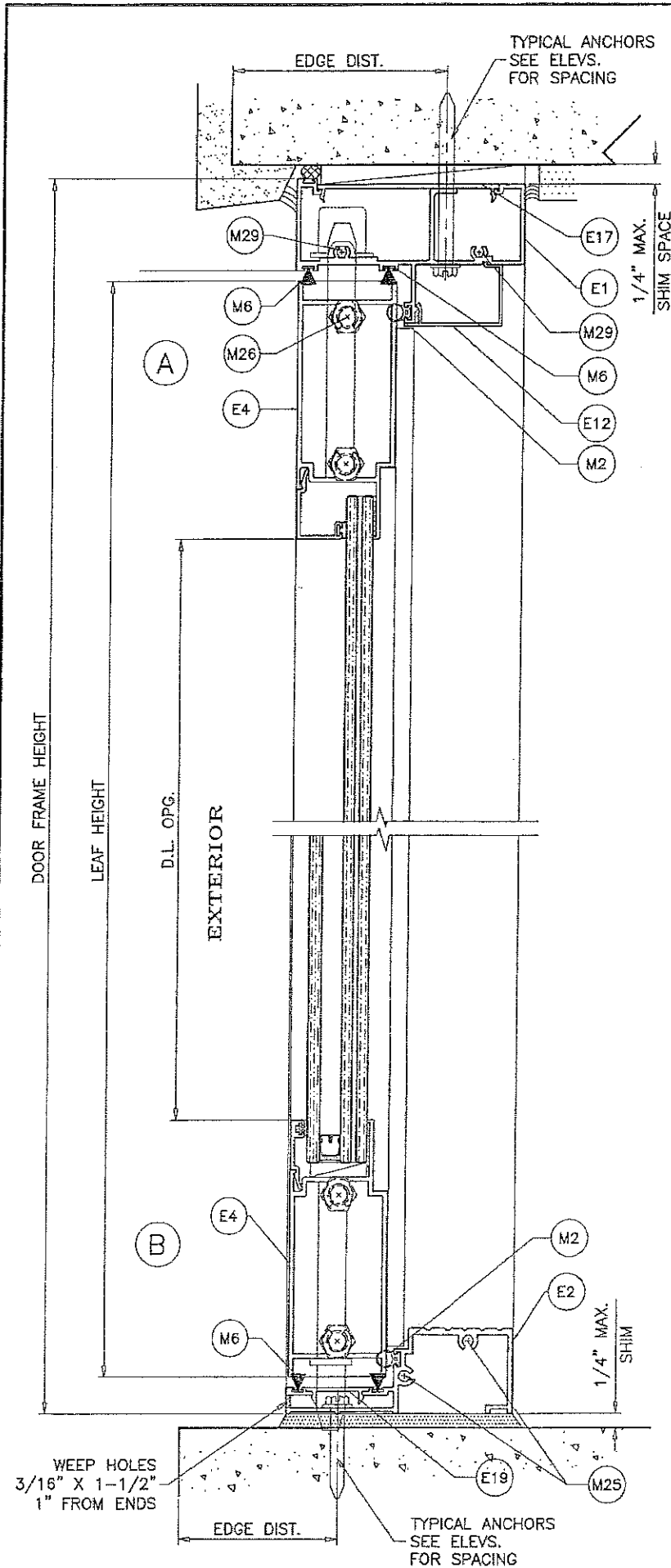

PRODUCT REVISED
 as complying with the Florida
 Building Code
 NOA-No. **16-0617.03**

Expiration Date **01/04/2023**

By
 Miami-Dade Product Control

DOOR DETAILS

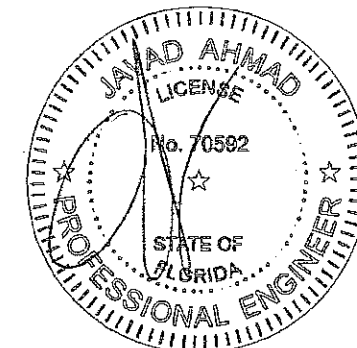

DEC 27 2017

af c
AL-FAROOQ CORPORATION
 ENGINEERS & PRODUCT DEVELOPMENT
 9360 SUNSET DRIVE, SUITE 220
 MIAMI, FLORIDA 33173 (C.A.N. 3538)
 TEL (305) 264-8100 FAX (305) 262-6978
 COMP--ANL \ W17-59ES

ES-EL300 ALUMINUM OUTSWING DOOR (L.M.I.)
E.S. WINDOWS, LLC
 3550 N.W. 49 STREET
 MIAMI, FL. 33142
 TEL (305) 638-5151 FAX (305) 638-5158

REVISIONS:	
no	date by description
A	07.21.17 REV. PER PER COMMENTS

date: 06-20-17	scale: 3/8" = 1"	dr. by: TARIQ	chk. by:
drawing no. W17-59			
sheet 5 of 12			

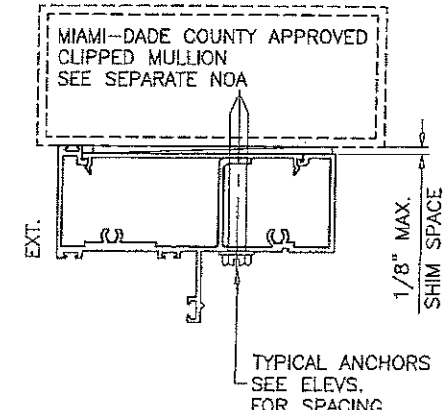
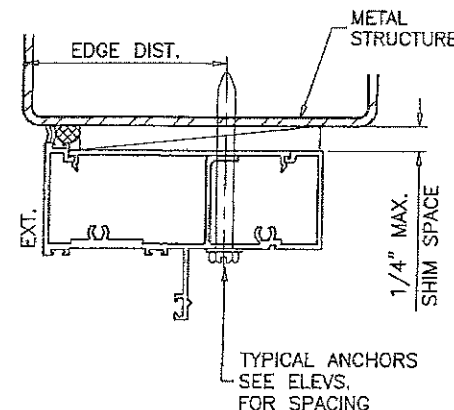
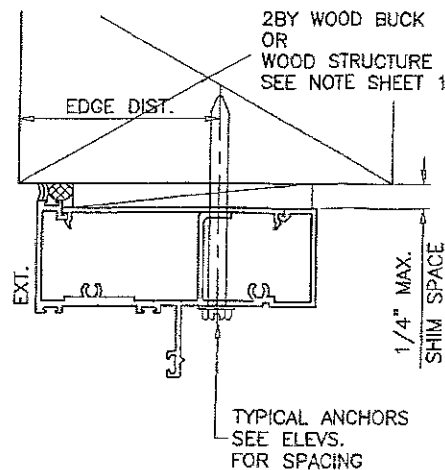
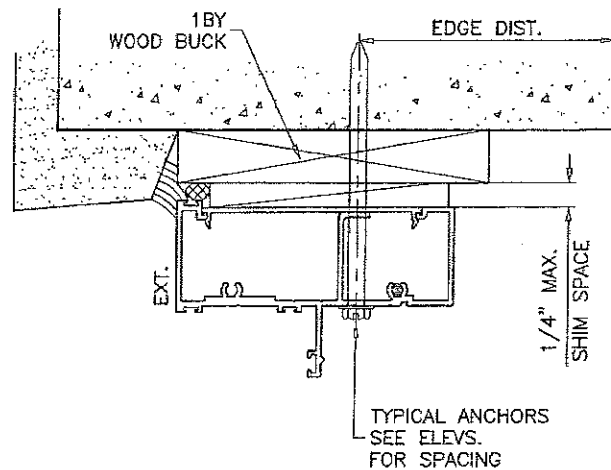

WOOD BUCKS AND METAL STRUCTURE NOT BY E.S. WINDOWS MUST SUSTAIN LOADS IMPOSED BY GLAZING SYSTEM AND TRANSFER THEM TO THE BUILDING STRUCTURE.

TYPICAL ANCHORS: SEE ELEV. FOR SPACING

1/4" DIA. ULTRACON BY 'ELCO' (Fu=177 KSI, Fy=155 KSI)
 INTO 2BY WOOD BUCKS OR WOOD STRUCTURES
 1-1/2" MIN. PENETRATION INTO WOOD (HEAD/JAMBS)

THRU 1BY BUCKS INTO CONC. OR BLOCKS
 1-3/4" MIN. EMBED INTO CONCRETE (HEAD/JAMBS)
 1-1/4" MIN. EMBED INTO BLOCKS (JAMBS)

DIRECTLY INTO CONCRETE OR GROUT FILLED BLOCKS
 1-3/4" MIN. EMBED INTO CONCRETE (HEAD/SILL/JAMBS)
 1-3/4" MIN. EMBED INTO GROUT FILLED BLOCKS (JAMBS)

1/4" DIA. TEKS OR SELF DRILLING SCREWS (GRADE 5 CRS)
 INTO MIAMI-DADE COUNTY APPROVED MULLIONS
 OR

INTO METAL STRUCTURES (HEAD/JAMBS)
 (3) THREADS MIN. PENETRATION BEYOND SUBSTRATE
 ALUMINUM: 1/8" THK. MIN. (6063-T5 MIN.)
 STEEL: 1/8" THK. MIN. (Fy = 36 KSI MIN.)
 (STEEL IN CONTACT WITH ALUMINUM TO BE PLATED OR PAINTED)

TYPICAL EDGE DISTANCE

INTO CONCRETE AND MASONRY = 2-1/2" MIN.
 INTO WOOD STRUCTURE = 1" MIN.
 INTO METAL STRUCTURE = 3/4" MIN.

WOOD AT HEAD OR JAMBS SG = 0.55 MIN.
 CONCRETE AT HEAD, SILL OR JAMBS f'c = 3000 PSI MIN.
 C-90 GROUT FILLED BLOCK AT JAMBS f'm = 2000 PSI MIN.

DOOR DETAILS

PRODUCT REVISED
 as complying with the Florida
 Building Code
 NOA-No. **16-0617.03**

Expiration Date **01/04/2023**

By 
 Miami-Dade Product Control

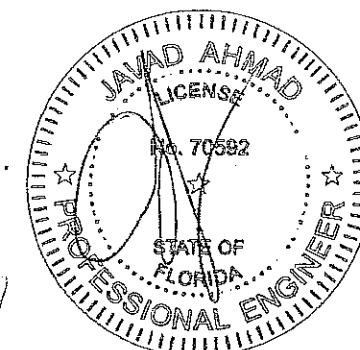

DEC 27 2017

af c

AL-FAROOQ CORPORATION
 ENGINEERS & PRODUCT DEVELOPMENT
 9360 SUNSET DRIVE, SUITE 220 (C.A.N. 3538)
 MIAMI, FLORIDA 33173
 TEL. (305) 264-8100 FAX. (305) 262-6978
 COMP-ANL W17-59ES

ES-EL300 ALUMINUM OUTSWING DOOR (L.M.I.)

E.S. WINDOWS, LLC
 3550 N.W. 49 STREET
 MIAMI, FL. 33142
 TEL. (305) 638-5151 FAX. (305) 638-5158

no.	date	by	description
A	07/21/17		NO CHANGE THIS SHEET

date: 06-20-17
 scale: 3/8" = 1"
 dr. by: TARIO
 chk. by:

drawing no.
W17-59

sheet 6 of 12

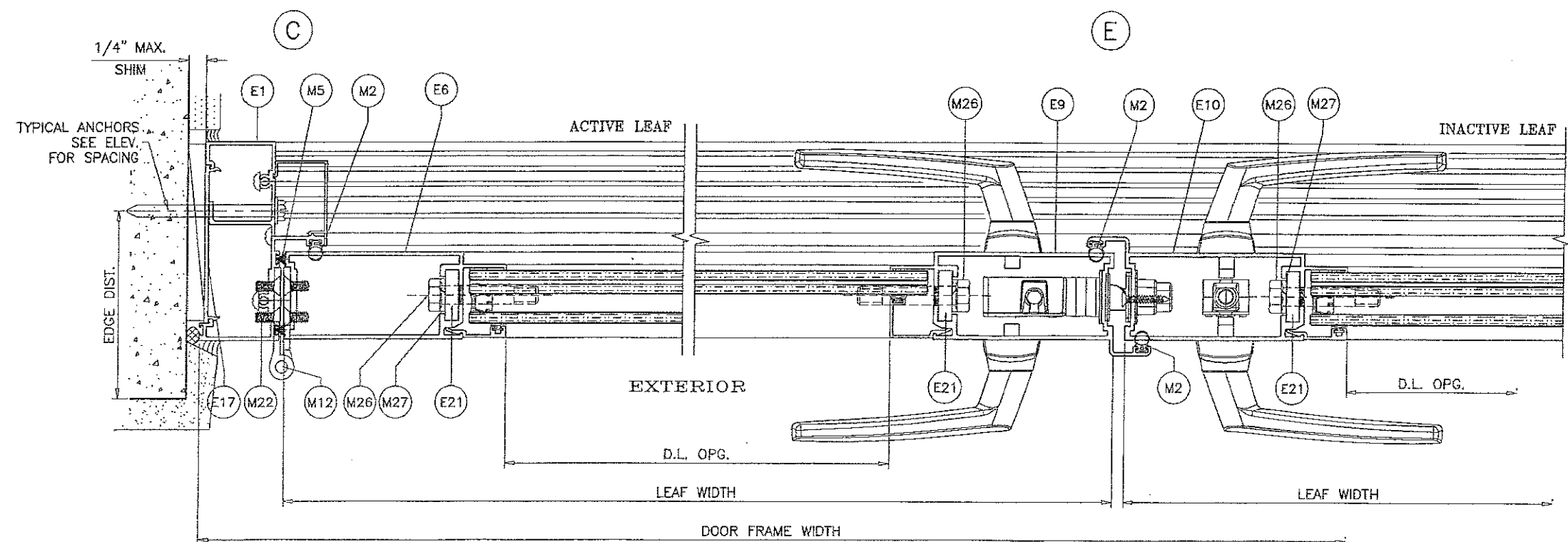
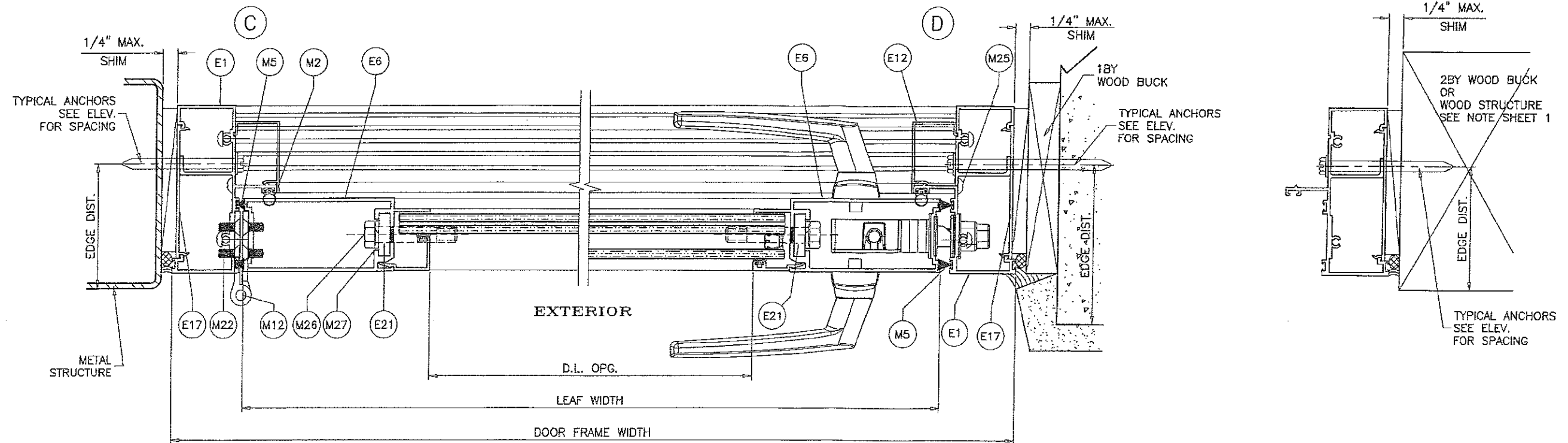

af c
AL-FAROOQ CORPORATION
 ENGINEERS & PRODUCT DEVELOPMENT
 9360 SUNSET DRIVE, SUITE 220 (C.A.N. 3538)
 MIAMI, FLORIDA 33173
 TEL. (305) 264-8100 FAX. (305) 262-6978
 COMP-ANL\W17-59ES

ES-EL300 ALUMINUM OUTSWING DOOR (L.M.I.)
E.S. WINDOWS, LLC
 3550 N.W. 49 STREET
 MIAMI, FL. 33142
 TEL. (305) 638-5151 FAX. (305) 638-5158

no	date	by	description
A	07.21.17		NO CHANGE THIS SHEET

date: 06-20-17
 scale: 3/8" = 1"
 dr. by: TARIQ
 chk. by:

drawing no.
W17-59
 sheet 7 of 12

DOOR DETAILS

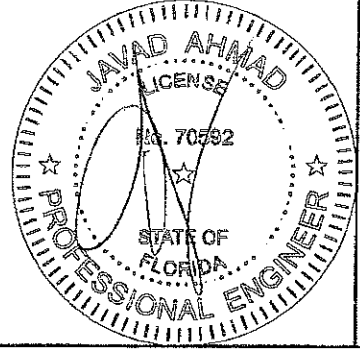

PRODUCT REVISED
 as complying with the Florida
 Building Code
 NOA-No. **16-0617.03**
 Expiration Date **01/04/2023**
 By **MIAMI-DADE PRODUCT CONTROL**

DAC 27 2017

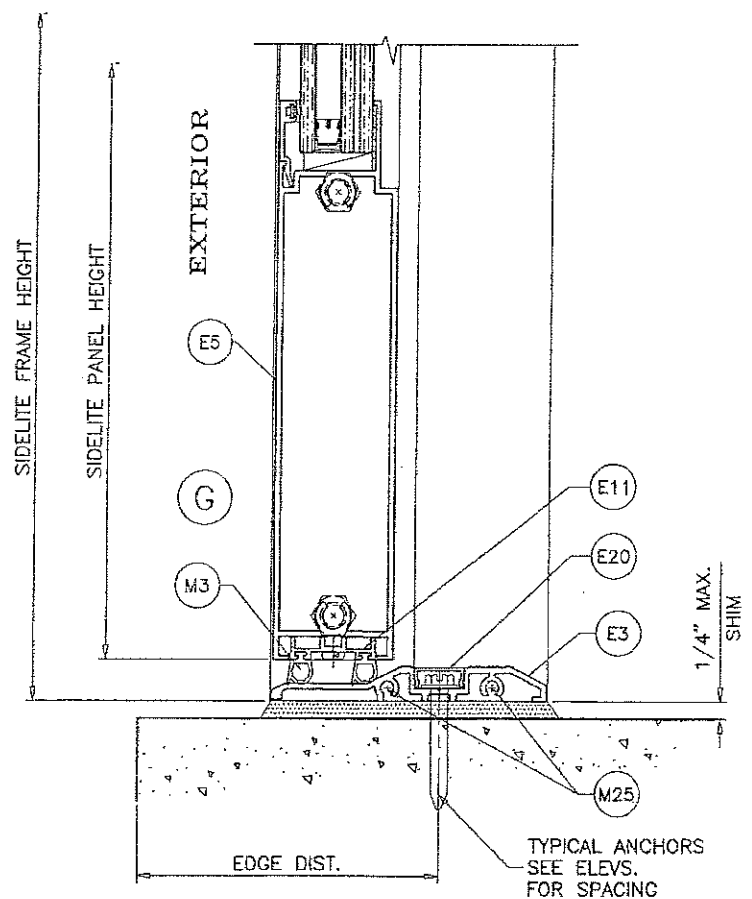
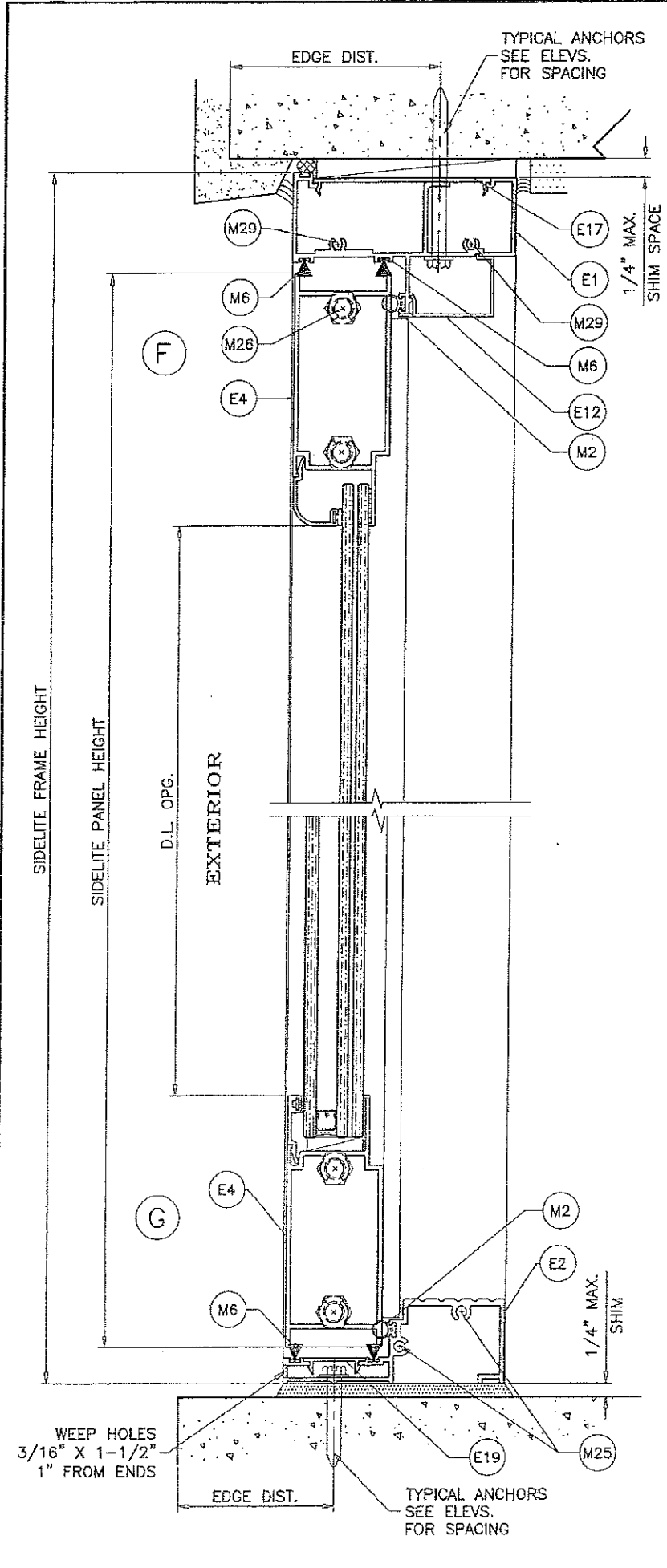

PRODUCT REVISED
 as complying with the Florida
 Building Code
 NOA-No. 16-0617.03
 Expiration Date 01/04/2023
 By *[Signature]*
 Miami-Dade Product Control

SIDELITE DETAILS

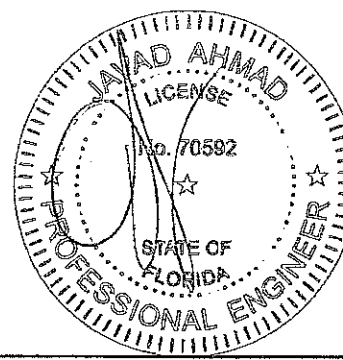

JLC 27 2017

AL-FAROOQ CORPORATION
 ENGINEERS & PRODUCT DEVELOPMENT
 9360 SUNSET DRIVE, SUITE 220
 MIAMI, FLORIDA 33173 (C.A.N. 3538)
 TEL (305) 264-8100 FAX (305) 262-6978
 COMP-ANL\W17-59ES

ES-EL300 ALUMINUM OUTSWING DOOR (L.M.I.)
 E.S. WINDOWS, LLC
 3550 N.W. 49 STREET
 MIAMI, FL. 33142
 TEL (305) 638-5151 FAX (305) 638-5158

no	date	by	description
A	07.21.17		REV. PER RER COMMENTS

date: 06-20-17
 scale: 3/8" = 1"
 dr: by: TARIO
 chk. by:

drawing no.
W17-59
 sheet 8 of 12

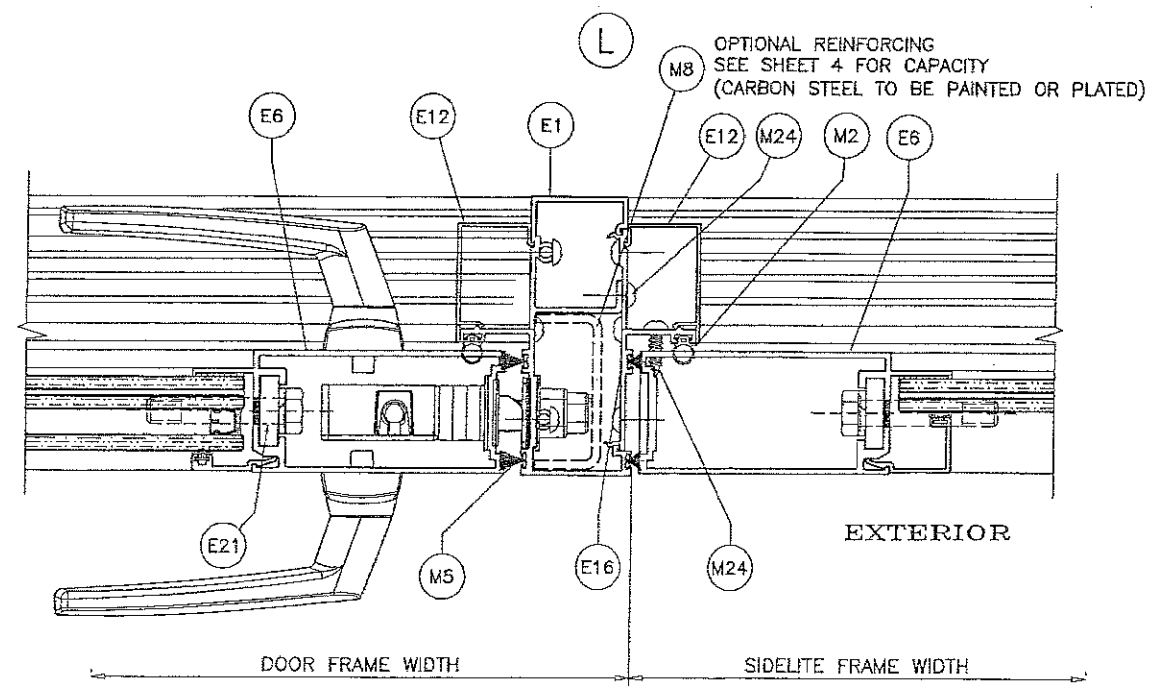
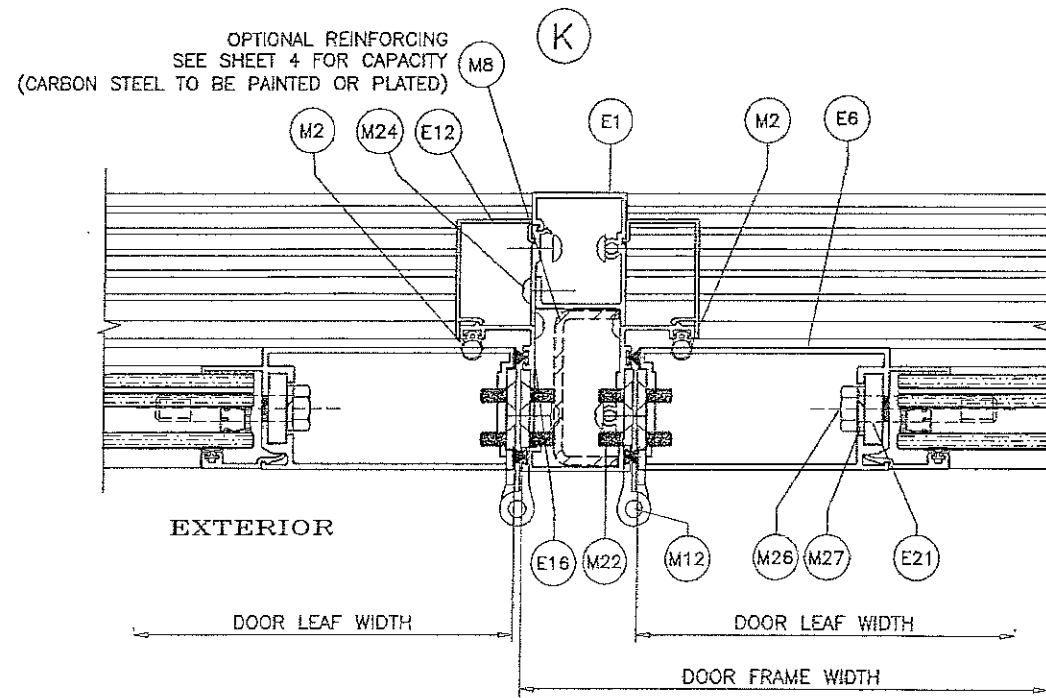
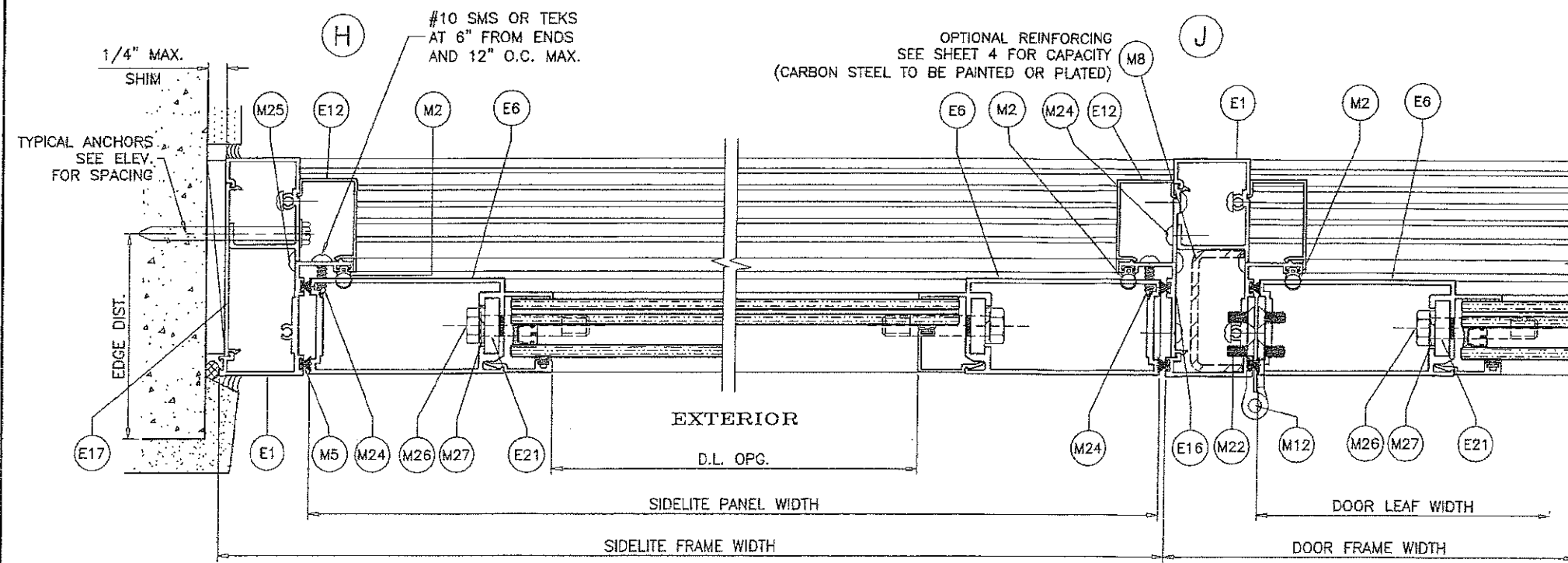

PRODUCT REVISED
 as complying with the Florida Building Code
 NOA-No. **16-0617.03**
 Expiration Date **01/04/2023**
 By *[Signature]*
 Miami-Date Product Control

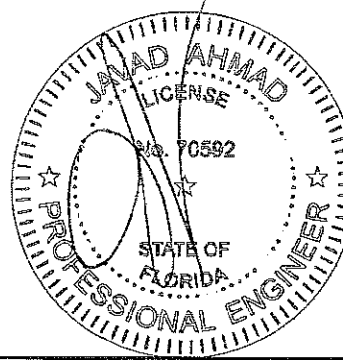

SIDELITE DETAILS

DEC 27 2017

AL-FAROOQ CORPORATION
 ENGINEERS & PRODUCT DEVELOPMENT
 9360 SUNSET DRIVE, SUITE 220
 MIAMI, FLORIDA 33173
 TEL (305) 264-8100 FAX (305) 262-9978
 (C.A.N. 3538)

ES-EL300 ALUMINUM OUTSWING DOOR (L.M.I.)
E.S. WINDOWS, LLC
 3550 N.W. 49 STREET
 MIAMI, FL. 33142
 TEL (305) 638-5151 FAX (305) 638-5158

no	date	description	rev. per	comments
A	07.21.17			

date: 06-20-17
 scale: 3/8" = 1"
 dr. by: TARIQ
 chk. by:

drawing no. **W17-59**
 sheet 9 of 12

COMP-ANL\W17-59FS

ITEM #	PART #	REQD.	DESCRIPTION	MATERIAL	MANF./SUPPLIER/REMARKS
E1	ES-EL300-001	3	FRAME HEAD/JAMB	6063-T6	-
E2	ES-EL300-002	1	FRAME SILL (STD.)	6063-T6	-
E3	ES-EL300-003	1	FRAME SILL (ADA)	6063-T6	-
E4	ES-EL300-004	2/ LEAF	TOP AND BOTTOM RAIL	6063-T6	-
E5	ES-EL300-005	1/ LEAF	HI-RISE BOTTOM RAIL	6063-T6	-
E6	ES-EL300-006	1/ LEAF	JAMB STILE	6063-T6	-
E9	ES-EL300-009	1	ASTRAGAL STILE (ACTIVE)	6063-T6	-
E10	ES-EL300-010	1	ASTRAGAL STILE (INACTIVE)	6063-T6	-
E11	ES-EL300-011	1	ADA SILL W'STRIP ADAPTER	6063-T6	-
E12	ES-EL300-012	1	FRAME COVER	6063-T5	-
E13	ES-EL300-013	4/ LEAF	GLASS STOP (LAM. GLASS)	6063-T5	-
E14	ES-EL300-014	4/ LEAF	GLASS STOP (LAM. GLASS)	6063-T5	-
E15	ES-EL300-015	4/ LEAF	GLASS STOP (INSUL. LAM. GLASS)	6063-T5	-
E16	ES-EL300-016	AS REQD.	SNAP IN FILLER	6063-T6	-
E17	ES-EL300-017	AS REQD.	EXTERIOR TRIM	6063-T6	-
E18	ES-EL300-018	AS REQD.	FRAME COVER	6063-T5	-
E19	ES-EL300-019	1	COVER STD. SILL	6063-T6	-
E20	ES-6011	1	COVER ADA SILL	6063-T6	-
E21	ACC-PL-020	1	BACK UP PLATE	6063-T6	-
M1	ES-5008A	AS REQD.	GLAZING GASKET	SILICONE	DUROMETER 65±5 SHORE A
M2	ES-P251-G05A	AS REQD.	EXTERIOR LEAF GASKET	SILICONE	DUROMETER 70±5 SHORE A
M3	ES-45T-G09	AS REQD.	ADA SILL GASKET	EPDM	DUROMETER 70±5 SHORE A
M4	ES-21-B04A	2/ LITE	SETTING BLOCKS AT 1/4 POINTS	SILICONE	DUROMETER 80±5 SHORE A
M5	W23221NG	AS REQD.	PILE W'STRIPPING	POLYPROPYLENE	-
M6	W23221NK	AS REQD.	PILE W'STRIPPING	POLYPROPYLENE	-
M7	W23381NK	AS REQD.	PILE W'STRIPPING	POLYPROPYLENE	-
M8	-	AS REQD.	MULLION REINF. CHANNEL (LENGTH = MULL HT. - 10")	A36 STEEL	-
M12	-	4/ LEAF	HINGE ASSEMBLY	-	HAGER
M22	#12-24 X 1/2"	-	HINGE FASTENERS	ST/ST	FH SMS
M23	#8 X 1/2"	-	W'STRIP ADAPTER FASTENERS	ST/ST	PH SMS
M24	#10 X 3/4"	-	FIX. PANEL FASTENERS, AT 6" FROM ENDS & 12" O.C.	ST/ST	PH SMS
M25	#12 X 1-3/4"	-	FRAME ASSEMBLY FASTENERS	ST/ST	PH SMS
M26	3/8-16 X 2"	-	LEAF/PANEL ASSEMBLY FASTENERS	ST/ST	HEX CAP FULL THREAD 18-8
M27	-	-	3/8" WASHER	ST/ST	HEX CAP FULL THREAD 18-8
M29	#10 X 1-3/4"	AS REQD.	HEAD ASSEMBLY FASTENERS	ST/ST	PH SMS

LOCKS:

ACTIVE LEAF:

SURFACE MOUNT 3 POINT MORTISE LOCK SYSTEM BY 'INTERLOCK USA'
KEY OPERATED ON EXTERIOR AND THUMB TURN ON INTERIOR
LEVER TYPE HANDLE AT 43-5/8" FROM BOTTOM
ACTIVATES SHOOT BOLTS ENGAGING 3/4" MIN. AT HEAD AND SILL
FASTENED WITH
(2) #10 X 3/4" FH SMS

INACTIVE LEAF:

SURFACE MOUNT 2 POINT LOCK SYSTEM BY 'INTERLOCK USA'
LEVER TYPE HANDLE AT 43-5/8" FROM BOTTOM
ACTIVATES SHOOT BOLTS ENGAGING 3/4" MIN. AT HEAD AND SILL
FASTENED WITH
(2) #10 X 3/4" FH SMS

HINGES:

4-1/2" LONG FLUSH MOUNT STEEL BUTT HINGES BY 'HAGER'
FASTENED WITH 12-24 X 1/2" FH MACHINE SCREWS
FOUR PER HASP(LEAF).
TOP AND BOTTOM HINGES AT 7-7/8" FROM EACH END
(1) HINGE REQD. AT MIDSPAN FOR 82" HIGH DOORS WITH
STANDARD THRESHOLD ONLY.
ALL OTHER DOORS TO HAVE INTERMEDIATE HINGES AT 26-3/8" O.C. MAX.

SEALANTS:

ALL FRAME AND LEAF JOINTS AND SEAMS SEALED WITH DOW CORNING 791 SILICONE.

PRODUCT REVISED
as complying with the Florida
Building Code
NOA-No. **16-0617.03**

Expiration Date **01/04/2023**

By 
Miami-Dade Product Control

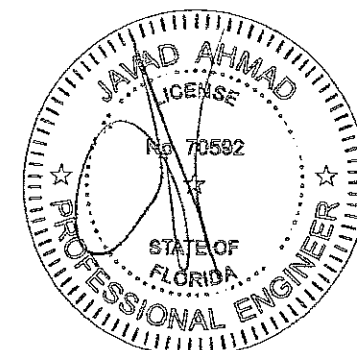

DEC 27 2017

afC
AL-FAROOQ CORPORATION
ENGINEERS & PRODUCT DEVELOPMENT
9360 SUNSET DRIVE, SUITE 220
MIAMI, FLORIDA 33173 (C.A.N. 3538)
TEL (305) 264-8100 FAX (305) 262-6978
COMP-ANL\W17-59ES

ES-EL300 ALUMINUM OUTSWING DOOR (L.M.I.)
E.S. WINDOWS, LLC
3550 N.W. 49 STREET
MIAMI, FL. 33142
TEL (305) 638-5151 FAX (305) 638-5158

revisions:	no	date	by	description
	A	07.21.17		REV. PER PER COMMENTS
date:	06-20-17			
scale:	3/8" = 1"			
dr. by:	TARIQ			
chk. by:				
drawing no.	W17-59			
sheet	10 of 12			

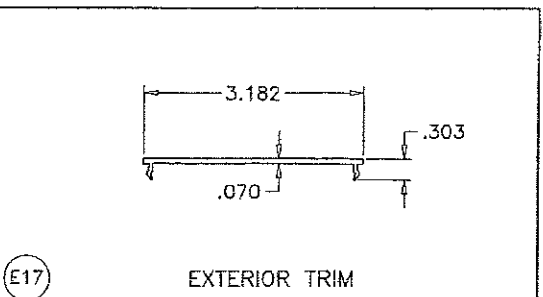
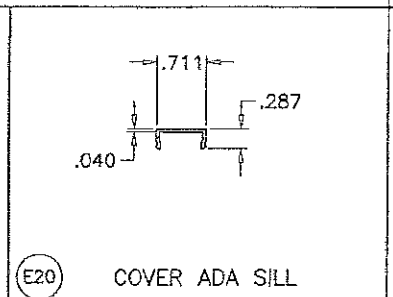
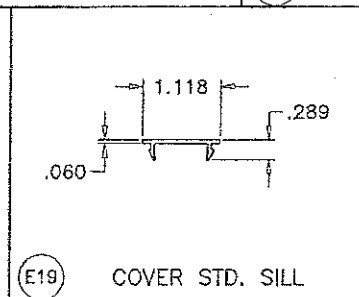
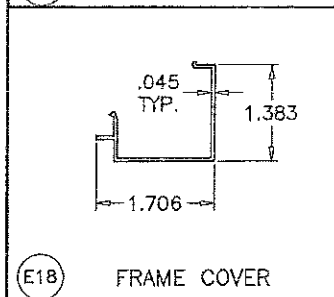
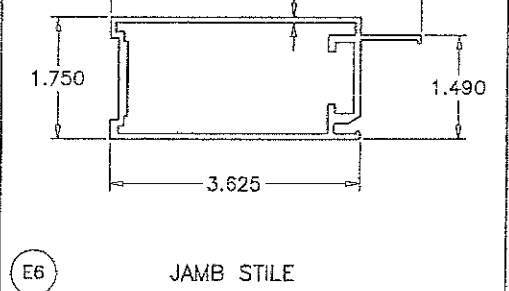
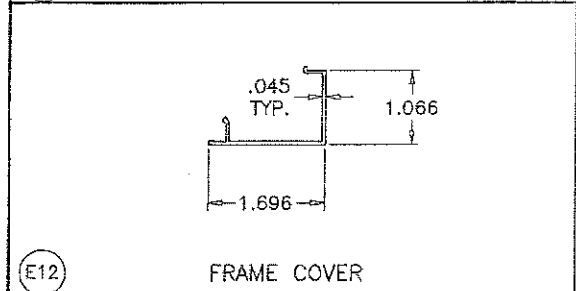
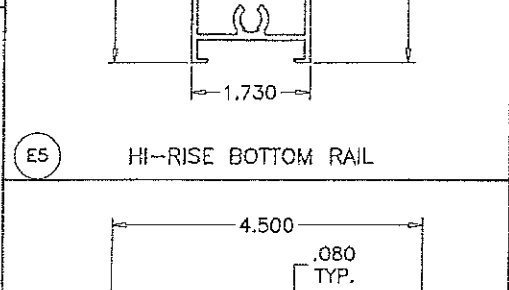
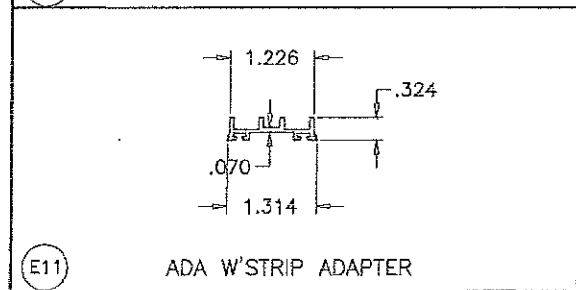
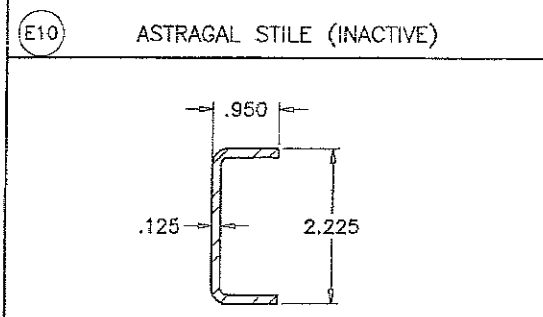
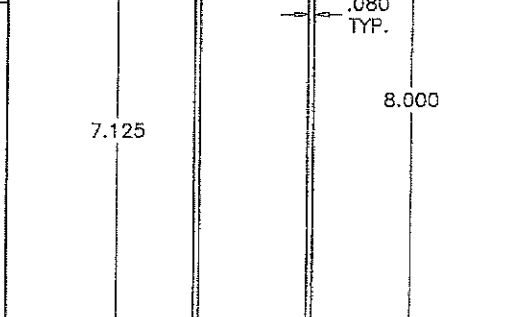
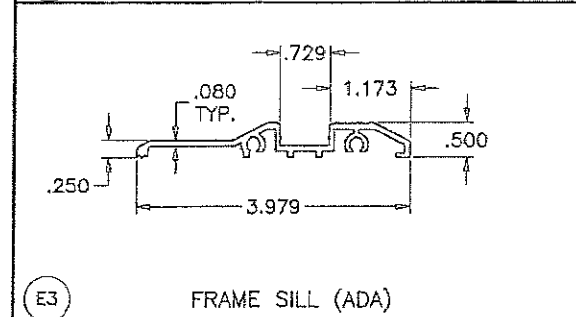
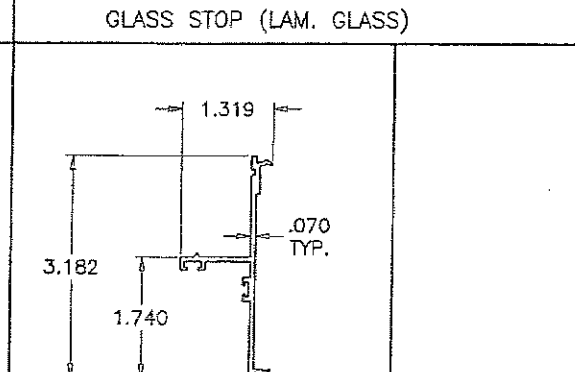
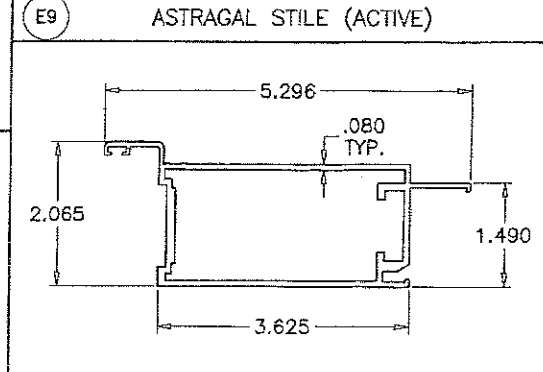
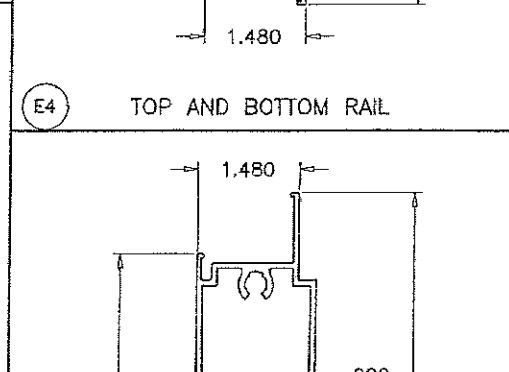
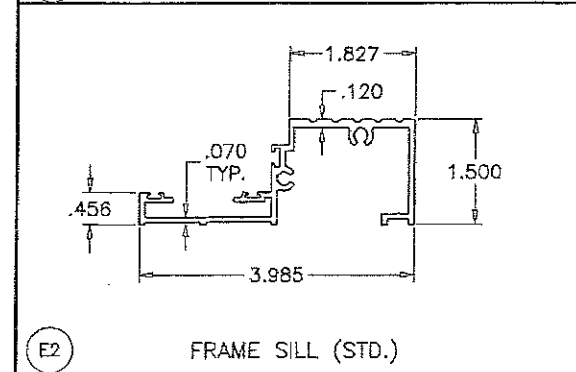
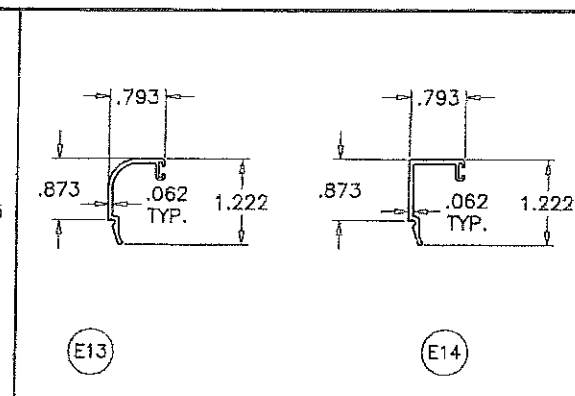
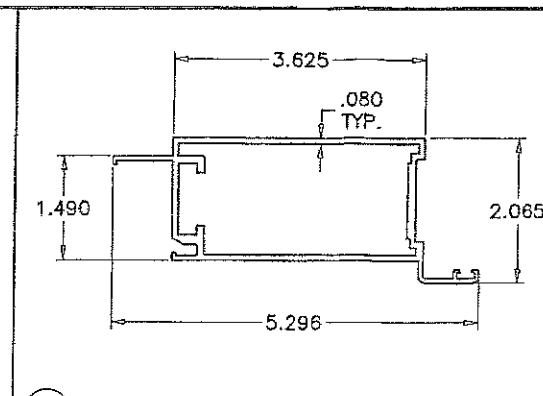
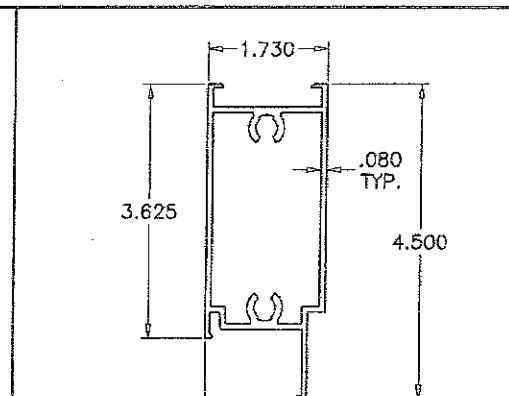
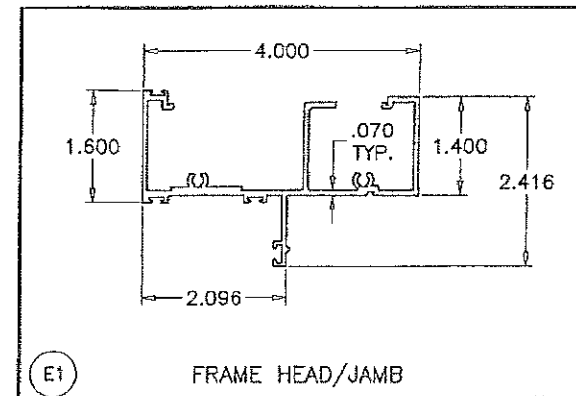

PRODUCT REVISED
as complying with the Florida
Building Code
NOA-No. **16-0617.03**

Expiration Date **01/04/2023**

By *[Signature]*
Miami-Dade Product Control

DEC 27 2017

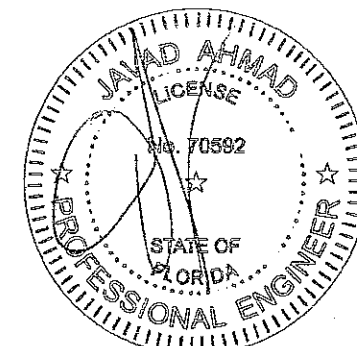

af c
AL-FAROOQ CORPORATION
ENGINEERS & PRODUCT DEVELOPMENT
9360 SUNSET DRIVE, SUITE 220
MIAMI, FLORIDA 33173
TEL: (305) 264-8100 FAX: (305) 262-6978
C.A.N. 3588

ES-EI300 ALUMINUM OUTSWING DOOR (L.M.I.)
E.S. WINDOWS, LLC
3550 N.W. 49 STREET
MIAMI, FL. 33142
TEL: (305) 638-5151 FAX: (305) 638-5158

revisions:	no.	date	by	description
	A	07/21/17		NO CHANGE THIS SHEET

date: 06-20-17
scale: 3/8" = 1"
dr. by: TARIQ
chk. by:

drawing no.
W17-59

sheet 11 of 12

COMP-ANL W17-59ES

