



DEPARTMENT OF REGULATORY AND ECONOMIC RESOURCES (RER)
BOARD AND CODE ADMINISTRATION DIVISION

MIAMI-DADE COUNTY
PRODUCT CONTROL SECTION

11805 SW 26 Street, Room 208
T (786) 315-2590 F (786) 315-2599

NOTICE OF ACCEPTANCE (NOA)

www.miamidade.gov/economy

Eco Window Systems, LLC
8502 NW 80 Street
Medley, FL 33166

SCOPE:

This NOA is being issued under the applicable rules and regulations governing the use of construction materials. The documentation submitted has been reviewed and accepted by Miami-Dade County RER - Product Control Section to be used in Miami Dade County and other areas where allowed by the Authority Having Jurisdiction (AHJ).

This NOA shall not be valid after the expiration date stated below. The Miami-Dade County Product Control Section (In Miami Dade County) and/or the AHJ (in areas other than Miami Dade County) reserve the right to have this product or material tested for quality assurance purposes. If this product or material fails to perform in the accepted manner, the manufacturer will incur the expense of such testing and the AHJ may immediately revoke, modify, or suspend the use of such product or material within their jurisdiction. RER reserves the right to revoke this acceptance, if it is determined by Miami-Dade County Product Control Section that this product or material fails to meet the requirements of the applicable building code.

This product is approved as described herein, and has been designed to comply with the Florida Building Code, including the High Velocity Hurricane Zone.

DESCRIPTION: Series "Eco-Guard 300" Aluminum Fixed Window – L.M.I.

APPROVAL DOCUMENT: Drawing No. **W09-20**, titled "Eco-Guard Series-300 Alum Fixed Wdw. (L.M.I.)", sheets 1 through 5 of 5, dated 03/23/09, with revision **E** dated 10/19/17, prepared by Al-Farooq Corporation, signed and sealed by Javad Ahmad, P.E., bearing the Miami-Dade County Product Control Revision stamp with the Notice of Acceptance number and expiration date by the Miami-Dade County Product Control Section.

MISSILE IMPACT RATING: Large and Small Missile Impact Resistant

LABELING: Each unit shall bear a permanent label with the manufacturer's name or logo, city, state, model/series, and following statement: "Miami-Dade County Product Control Approved", unless otherwise noted herein.

RENEWAL of this NOA shall be considered after a renewal application has been filed and there has been no change in the applicable building code negatively affecting the performance of this product.

TERMINATION of this NOA will occur after the expiration date or if there has been a revision or change in the materials, use, and/or manufacture of the product or process. Misuse of this NOA as an endorsement of any product, for sales, advertising or any other purposes shall automatically terminate this NOA. Failure to comply with any section of this NOA shall be cause for termination and removal of NOA.

ADVERTISEMENT: The NOA number preceded by the words Miami-Dade County, Florida, and followed by the expiration date may be displayed in advertising literature. If any portion of the NOA is displayed, then it shall be done in its entirety.

INSPECTION: A copy of this entire NOA shall be provided to the user by the manufacturer or its distributors and shall be available for inspection at the job site at the request of the Building Official.

This NOA **revises NOA# 15-0715.10** and consists of this page 1 and evidence pages E-1 and E-2, as well as approval document mentioned above.

The submitted documentation was reviewed by **Sifang Zhao, P.E.**



S.Z.
01/05/2018

NOA No. 17-1102.20
Expiration Date: June 17, 2019
Approval Date: January 11, 2018
Page 1

NOTICE OF ACCEPTANCE: EVIDENCE SUBMITTED

A. DRAWINGS

1. Manufacturer's die drawings and sections.
(Submitted under NOA#09-0413.08)
2. Drawing No **W09-20**, titled "Eco-Guard Series-300 Alum. Fixed Wdw. (L.M.I.)", sheets 1 through 5 of 5, dated 03/23/09, with revision **E** dated 10/19/17, prepared by Al-Farooq Corporation, signed and sealed by Javad Ahmad, P.E.

B. TESTS

1. Test reports on: 1) Air Infiltration Test, per FBC, TAS 202-94
2) Uniform Static Air Pressure Test, Loading per FBC TAS 202-94
3) Water Resistance Test, per FBC, TAS 202-94
along with installation diagram of a 97 1/4" wide x 96 1/8" high Eco-Guard series 300 aluminum double fixed window, prepared by Hurricane Engineering & Testing Inc., Test Report No. **HETI-08-2192A**, dated 01/15/09, signed and sealed by Candido F. Font, P.E. *(Submitted under NOA#09-0413.08)*
2. Test reports on: 1) Large Missile Impact Test per FBC, TAS 201-94
2) Cyclic Wind Pressure Loading per FBC, TAS 203-94
along with installation diagram of a 97 1/4" wide x 96 1/8" high Eco-Guard series 300 aluminum double fixed window, prepared by Hurricane Engineering & Testing Inc., Test Report No. **HETI-08-2192B**, dated 01/15/09, signed and sealed by Candido F. Font, P.E. *(Submitted under NOA#09-0413.08)*
3. Test reports on: 1) Air Infiltration Test, per FBC, TAS 202-94
2) Uniform Static Air Pressure Test, Loading per FBC, TAS 20294
3) Water Resistance Test, per FBC, TAS 202-94
along with installation diagram of a 48 1/4" wide x 96 3/8" high Eco-Guard series 300 aluminum circular arch top fixed window, prepared by Hurricane Engineering & Testing Inc., Test Report No. **HETI-08-2193A**, dated 01/15/09, signed and sealed by Candido F. Font, P.E. *(Submitted under NOA#09-0413.08)*
4. Test reports on: 1) Large Missile Impact Test per FBC, TAS 201-94
2) Cyclic Wind Pressure Loading per FBC, TAS 203-94
along with installation diagram of a 48 1/4" wide x 96 3/8" high Eco-Guards 300 aluminum circular arch top fixed window, prepared by Hurricane Engineering & Testing Inc., Test Report No. **HETI-08-2193B**, dated 01/15/09, signed and sealed by Candido F. Font, P.E. *(Submitted under NOA#09-0413.08)*
5. Test reports on: 1) Large Missile Impact Test per FBC, TAS 201-94
2) Cyclic Wind Pressure Loading per FBC, TAS 203-94
along with installation diagram of a 47 5/8" wide x 96" high Eco-Guard series 300 aluminum triangular top fixed window, prepared by Hurricane Engineering & Testing Inc., Test Report No. **HETI-08-2194**, dated 01/15/09, signed and sealed by Candido F. Font, P.E. *(Submitted under NOA#09-0413.08)*

Sifang Zhao

Sifang Zhao, P.E.

Product Control Examiner

NOA No. 17-1102.20

Expiration Date: June 17, 2019

Approval Date: January 11, 2018

Eco Window Systems, LLC.

NOTICE OF ACCEPTANCE: EVIDENCE SUBMITTED

B. TESTS (CONTINUED)

6. Test reports on: 1) Air Infiltration Test, per FBC, TAS 202-94
2) Uniform Static Air Pressure Test, Loading per FBC TAS 202-94
3) Water Resistance Test, per FBC, TAS 202-94
along with installation diagram of a 50 5/8" wide x 63 1/4" high Eco-Guard series 300 aluminum fixed window, prepared by Hurricane Engineering & Testing Inc., Test Report No. **HETI-08-2195A**, dated 01/15/09, signed and sealed by Candido F. Font, P.E. (*Submitted under NOA#09-0413.08*)

C. CALCULATIONS

1. Anchor verification calculations and structural analysis, complying with **FBC 6th Edition (2017)**, dated 10/13/17, prepared by Al-Farooq Corporation, signed and sealed by Javad Ahmad, P.E.
2. Glazing complies with **ASTM E1300-09**

D. QUALITY ASSURANCE

1. Miami-Dade Department of Regulatory and Economic Resources (RER)

E. MATERIAL CERTIFICATIONS

1. Notice of Acceptance No. **16-1117.01** issued to **Kuraray America, Inc.** for their "**Trosifol® Ultraclear, Clear and Color PVB Interlayers**" dated 01/19/17, expiring on 07/08/19.
2. Notice of Acceptance No. **14-0916.11** issued to **Kuraray America, Inc.** for their "**SentryGlas® (Clear and White) Glass Interlayers**" dated 06/25/15, expiring on 07/04/18.

F. STATEMENTS

1. Statement letter of conformance, complying with **FBC 5th Edition (2014)**, with **FBC 6th Edition (2017)**, and of no financial interest, dated October 13, 2017, issued by Al-Farooq Corporation, signed and sealed by Javad Ahmad, P.E.

G. OTHER

1. Notice of Acceptance No. **15-0715.10**, issued to Eco Window Systems, LLC for their Series "Eco-Guard 300" Aluminum Fixed Window – L.M.I., approved on 09/03/15 and expiring on 06/17/19.

Sifang Zhao

Sifang Zhao, P.E.

Product Control Examiner

NOA No. 17-1102.20

Expiration Date: June 17, 2019

Approval Date: January 11, 2018

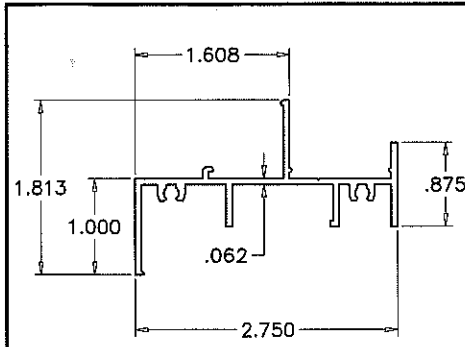

① FRAME HEAD/SILL/JAMB

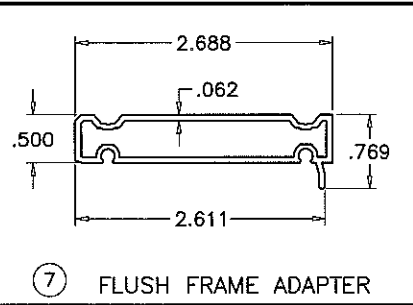

⑦ FLUSH FRAME ADAPTER

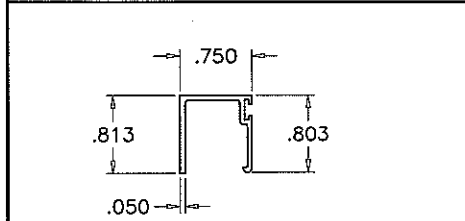

② GLAZING BEAD

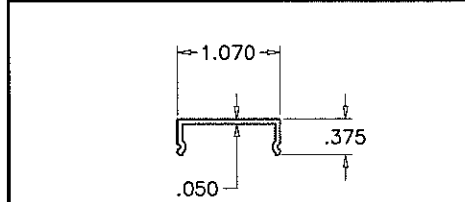

③ ANCHOR COVER

**ECO-GUARD SERIES-300
ALUMINUM FIXED WINDOW**

DESIGN LOAD RATINGS FOR THESE WINDOWS TO BE AS PER CHARTS SHOWN ON SHEETS 2.

APPROVAL APPLIES TO SINGLE UNITS OR SIDE BY SIDE COMBINATIONS OF FIX./FIX. OR FIXED WITH OTHER WINDOW TYPES IN MODULES OF TWO OR MORE WINDOWS USING MIAMI-DADE COUNTY APPROVED MULLIONS IN BETWEEN. LOWER DESIGN PRESSURE FROM WINDOWS OR MULLION APPROVAL WILL APPLY TO ENTIRE SYSTEM.

THIS PRODUCT HAS BEEN DESIGNED AND TESTED TO COMPLY WITH THE REQUIREMENTS OF THE 2014 (5TH EDITION)/2017 (6TH EDITION) FLORIDA BUILDING CODE INCLUDING HIGH VELOCITY HURRICANE ZONE (HVHZ).

1BY OR 2BY WOOD BUCKS & BUCK FASTENERS BY OTHERS, MUST BE DESIGNED AND INSTALLED ADEQUATELY TO TRANSFER APPLIED PRODUCT LOADS TO THE BUILDING STRUCTURE.

ANCHORS SHALL BE CORROSION RESISTANT, SPACED AS SHOWN ON DETAILS AND INSTALLED PER MANUF'S INSTRUCTIONS. SPECIFIED EMBEDMENT TO BASE MATERIAL SHALL BE BEYOND WALL DRESSING OR STUCCO.

A LOAD DURATION INCREASE IS USED IN DESIGN OF ANCHORS INTO WOOD ONLY.

ALL SHIMS TO BE HIGH IMPACT, NON-METALLIC AND NON-COMPRESSIBLE.

MATERIALS INCLUDING BUT NOT LIMITED TO STEEL/METAL SCREWS, THAT COME INTO CONTACT WITH OTHER DISSIMILAR MATERIALS SHALL MEET THE REQUIREMENTS OF THE 2014/2017 FLORIDA BLDG. CODE & ADOPTED STANDARDS.

THIS PRODUCT APPROVAL IS GENERIC AND DOES NOT PROVIDE INFORMATION FOR A SITE SPECIFIC PROJECT, I.E. LIFE SAFETY OF THIS PRODUCT, ADEQUACY OF STRUCTURE RECEIVING THIS PRODUCT AND SEALING AROUND OPENING FOR WATER INFILTRATION RESISTANCE ETC. CONDITIONS NOT SHOWN IN THIS DRAWING ARE TO BE ANALYZED SEPARATELY, AND TO BE REVIEWED BY BUILDING OFFICIAL.

THESE WINDOWS ARE RATED FOR LARGE & SMALL MISSILE IMPACT. SHUTTERS ARE NOT REQUIRED.

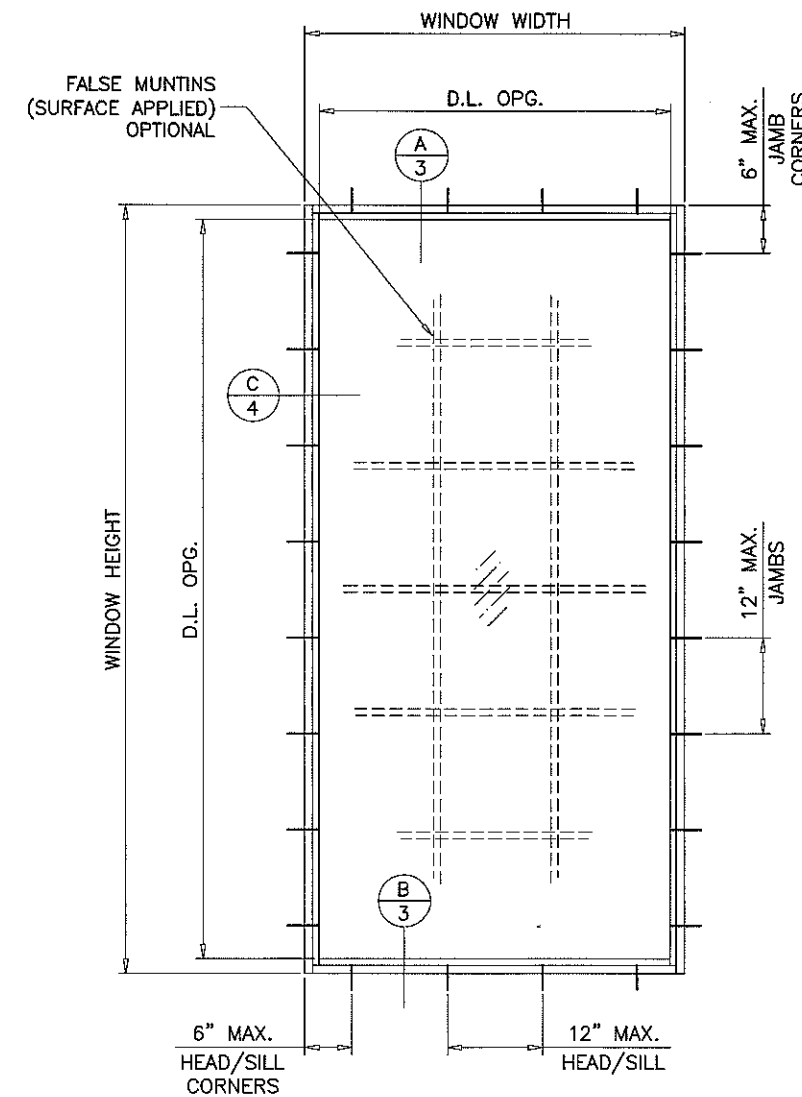

TYPICAL ELEVATION

GLASS D.L.O. DIMS.

D.L.O. HEIGHT = WINDOW HEIGHT - 3.625"
D.L.O. WIDTH = WINDOW WIDTH - 3.625"

PRODUCT REVISED
as complying with the Florida
Building Code
Acceptance No 17-402.20
Expiration Date 06/17/2019
By Sifang Zhao
Miami Dade Product Control

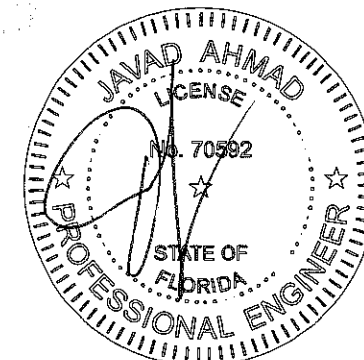

af c
AL-FAROOQ CORPORATION
ENGINEERS & PRODUCT DEVELOPMENT
9360 SUNSET DRIVE, SUITE 220
MIAMI, FLORIDA 33173 (C.A.N. 3538)
TEL. (305) 264-8100 FAX (305) 262-6978
COMP-ANL W09-20ECO

ECO-GUARD SERIES-300 ALUM FIXED WDW. (L.M.I.)
ECO WINDOW SYSTEMS, LLC.
8502 N.W. 80th STREET
MEDLEY, FL. 33166
TEL. (305) 885-5299 FAX (305) 885-5902

revisions:	no	date	by	description
	A	05.18.09		REV. PER BCCO COMMENTS
	B	01.30.12		UPDATED TO 2010 FBC
	C	01.11.13		MANUF. ADDRESS REV.
	D	07.08.15		UPDATED TO 2014 FBC
	E	10.15.17		UPDATED TO 2017 FBC

date: 03-23-09
scale: 1/2" = 1'-0"
dr. by: TARIQ
chk. by:
drawing no.
W09-20
sheet 1 of 5

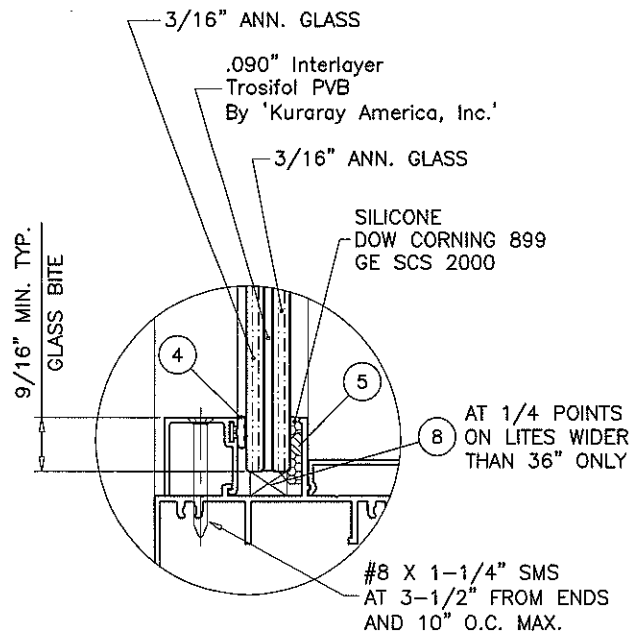

GLASS TYPE 'C'

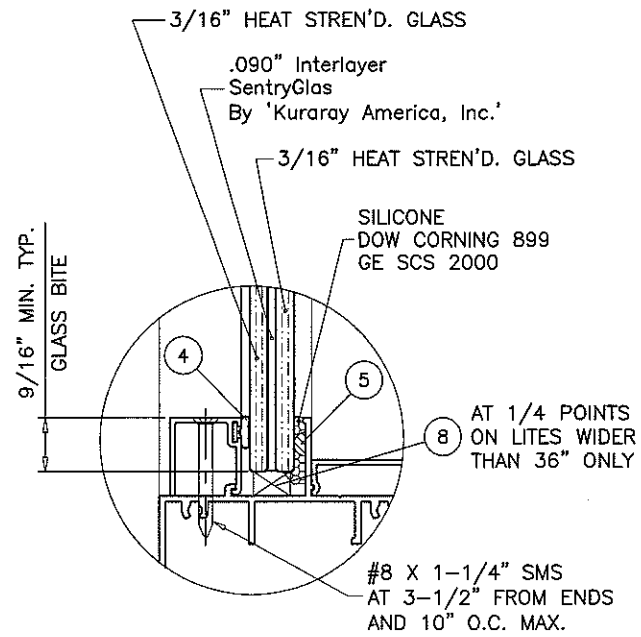

GLASS TYPE 'D'

GLAZING OPTIONS

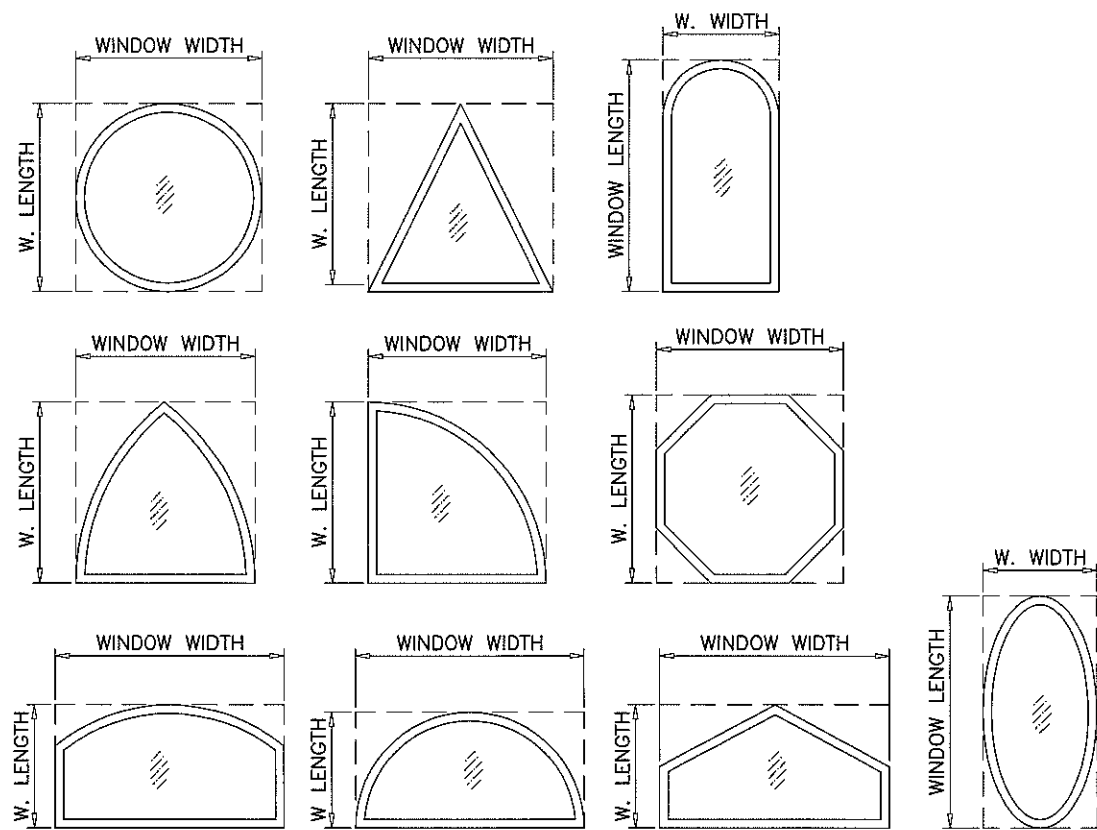

ALLOWABLE LOADS FOR ALTERNATE SHAPES AS SHOWN ABOVE OR SIMILAR CAN BE VERIFIED BY INSCRIBING PICTURE WINDOW SHAPE WITHIN SQUARE OR RECTANGLE AS SHOWN IN DOTTED LINES AND OBTAINING ALLOWABLE LOADS FROM THOSE SHAPES.

DESIGN LOAD CAPACITY - PSF					
WINDOW DIMS.		GLASS TYPE 'C'		GLASS TYPE 'D'	
WIDTH (W)	LENGTH (L)	EXT.(+)	INT.(-)	EXT.(+)	INT.(-)
24"	36"	75.0	80.0	80.0	90.0
30"		75.0	80.0	80.0	90.0
36"		75.0	80.0	80.0	90.0
42"		75.0	80.0	80.0	90.0
48"		75.0	80.0	80.0	90.0
54"		75.0	80.0	80.0	90.0
60"		75.0	80.0	80.0	90.0
66"		75.0	80.0	80.0	90.0
72"	75.0	80.0	80.0	90.0	
24"	48"	75.0	80.0	80.0	90.0
30"		75.0	80.0	80.0	90.0
36"		75.0	80.0	80.0	90.0
42"		75.0	80.0	80.0	90.0
48"		75.0	80.0	80.0	90.0
54"		75.0	80.0	80.0	90.0
60"		75.0	80.0	80.0	90.0
66"		75.0	80.0	80.0	90.0
72"	75.0	76.6	80.0	90.0	
24"	60"	75.0	80.0	80.0	90.0
30"		75.0	80.0	80.0	90.0
36"		75.0	80.0	80.0	90.0
42"		75.0	80.0	80.0	90.0
48"		75.0	80.0	80.0	90.0
54"		66.8	71.3	80.0	90.0
60"		60.2	64.2	80.0	90.0
66"		60.2	64.2	80.0	90.0
72"	60.2	64.2	80.0	90.0	
24"	72"	75.0	80.0	80.0	90.0
30"		75.0	80.0	80.0	90.0
36"		75.0	80.0	80.0	90.0
42"		75.0	80.0	80.0	90.0
48"		75.0	76.6	80.0	90.0
54"		66.8	71.3	80.0	90.0
60"		60.2	64.2	80.0	90.0
66"		60.2	64.2	80.0	90.0
72"	60.2	64.2	80.0	90.0	
24"	84"	75.0	80.0	80.0	90.0
30"		75.0	80.0	80.0	90.0
36"		75.0	80.0	80.0	90.0
42"		70.0	70.0	80.0	90.0
48"		65.6	65.6	80.0	90.0
54"		64.3	64.3	80.0	90.0
60"		75.0	80.0	80.0	90.0
66"		75.0	80.0	80.0	90.0
72"	75.0	76.2	80.0	90.0	
78"	64.6	64.6	80.0	90.0	
84"	59.9	59.9	80.0	90.0	
24"	96"	75.0	80.0	80.0	90.0
30"		75.0	80.0	80.0	90.0
36"		75.0	80.0	80.0	90.0
42"		75.0	76.2	80.0	90.0
48"		64.6	64.6	80.0	90.0
54"		61.5	61.5	80.0	90.0
60"		75.0	80.0	80.0	90.0
66"		75.0	80.0	80.0	90.0
72"	75.0	80.0	80.0	90.0	
78"	74.5	74.5	80.0	90.0	
84"	61.5	61.5	80.0	90.0	
24"	108"	75.0	80.0	80.0	90.0
30"		75.0	80.0	80.0	90.0
36"		75.0	80.0	80.0	90.0
42"		75.0	80.0	80.0	90.0
48"		75.0	80.0	80.0	90.0
54"		75.0	80.0	80.0	90.0
60"		75.0	80.0	80.0	90.0
66"		75.0	80.0	80.0	90.0
72"	75.0	80.0	80.0	90.0	
78"	74.5	74.5	80.0	90.0	
24"	120"	75.0	80.0	80.0	90.0
30"		75.0	80.0	80.0	90.0
36"		74.5	74.5	80.0	90.0

DESIGN LOAD CAPACITY - PSF					
WINDOW DIMS.		GLASS TYPE 'C'		GLASS TYPE 'D'	
WIDTH (W)	LENGTH (L)	EXT.(+)	INT.(-)	EXT.(+)	INT.(-)
26-1/2"	26"	75.0	80.0	80.0	90.0
37"		75.0	80.0	80.0	90.0
53-1/8"		75.0	80.0	80.0	90.0
74"		75.0	80.0	80.0	90.0
26-1/2"	38-3/8"	75.0	80.0	80.0	90.0
37"		75.0	80.0	80.0	90.0
53-1/8"		75.0	80.0	80.0	90.0
74"		75.0	80.0	80.0	90.0
26-1/2"	50-5/8"	75.0	80.0	80.0	90.0
37"		75.0	80.0	80.0	90.0
53-1/8"		71.3	76.0	80.0	90.0
74"		71.3	73.1	80.0	90.0
26-1/2"	63"	75.0	80.0	80.0	90.0
37"		75.0	80.0	80.0	90.0
53-1/8"		67.9	72.5	80.0	90.0
74"		67.9	72.5	80.0	90.0
26-1/2"	76"	75.0	80.0	80.0	90.0
37"		75.0	80.0	80.0	90.0
53-1/8"		67.9	69.9	80.0	90.0
74"		67.9	69.9	80.0	90.0

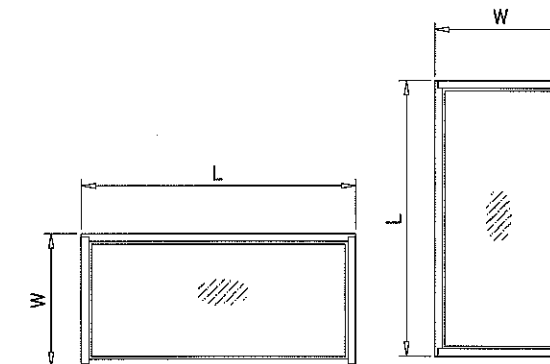

NOTE: WIDTH AND LENGTH DIMENSIONS CAN BE ORIENTED VERTICALLY OR HORIZONTALLY AS SHOWN ABOVE.

NOTE: GLASS CAPACITIES ON THIS SHEET ARE BASED ON ASTM E1300-09 (3 SEC. GUSTS).

PRODUCT REVISED as complying with the Florida Building Code Acceptance No. 11-1102-20 Expiration Date 06/17/2019

By Sifang zhao Miami Dade Product Control

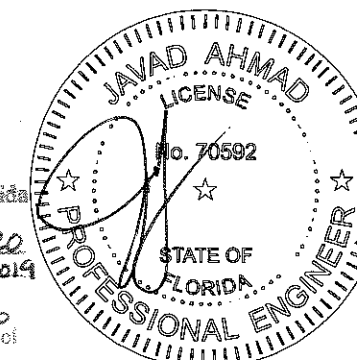

af c
AL-FAROOQ CORPORATION
 ENGINEERS & PRODUCT DEVELOPMENT
 9360 SUNSET DRIVE, SUITE 220
 MIAMI, FLORIDA 33173 (C.A.N. 3538)
 TEL. (305) 264-8100 FAX. (305) 262-6978
 COMP-ANL W09-20ECC

ECO-GUARD SERIES-300 ALUM FIXED WDW. (L.M.I.)
ECO WINDOW SYSTEMS, LLC.
 8502 N.W. 80th STREET
 MEDLEY, FL. 33166
 TEL. (305) 885-5299 FAX (305) 885-5902

no	date	by	description
A	05.18.09	REV. PER BCCO COMMENTS	
B	01.30.12	UPDATED TO 2010 FBC	
C	01.11.13	MANUF. ADDRESS REV.	
D	07.08.15	UPDATED TO 2014 FBC	
E	10.19.17	UPDATED TO 2017 FBC	

date: 03-23-09
 scale: 1/2"=1'-0"
 dr. by: TARIQ
 chk. by:
 drawing no. **W09-20**
 sheet 2 of 5

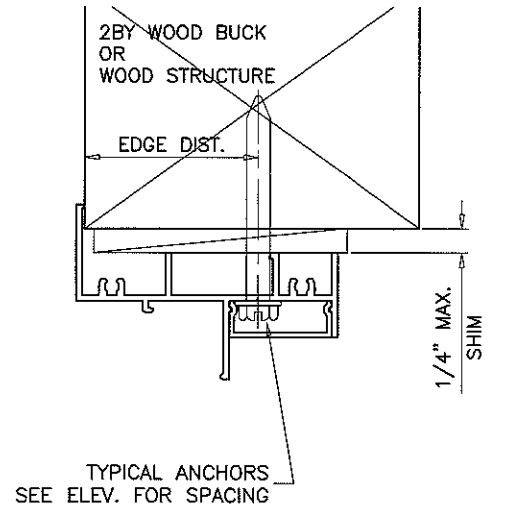
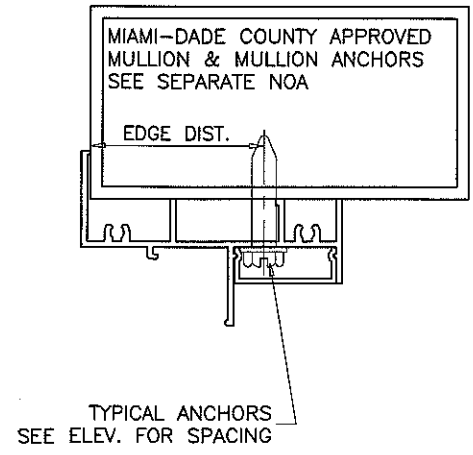
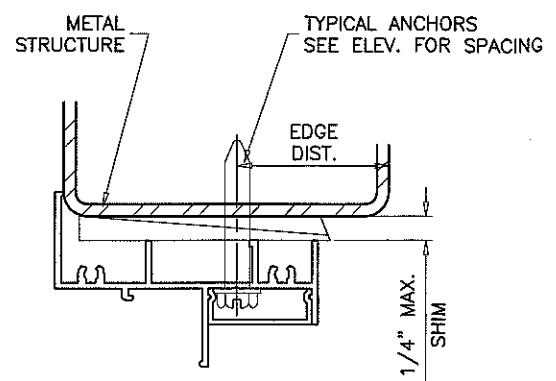
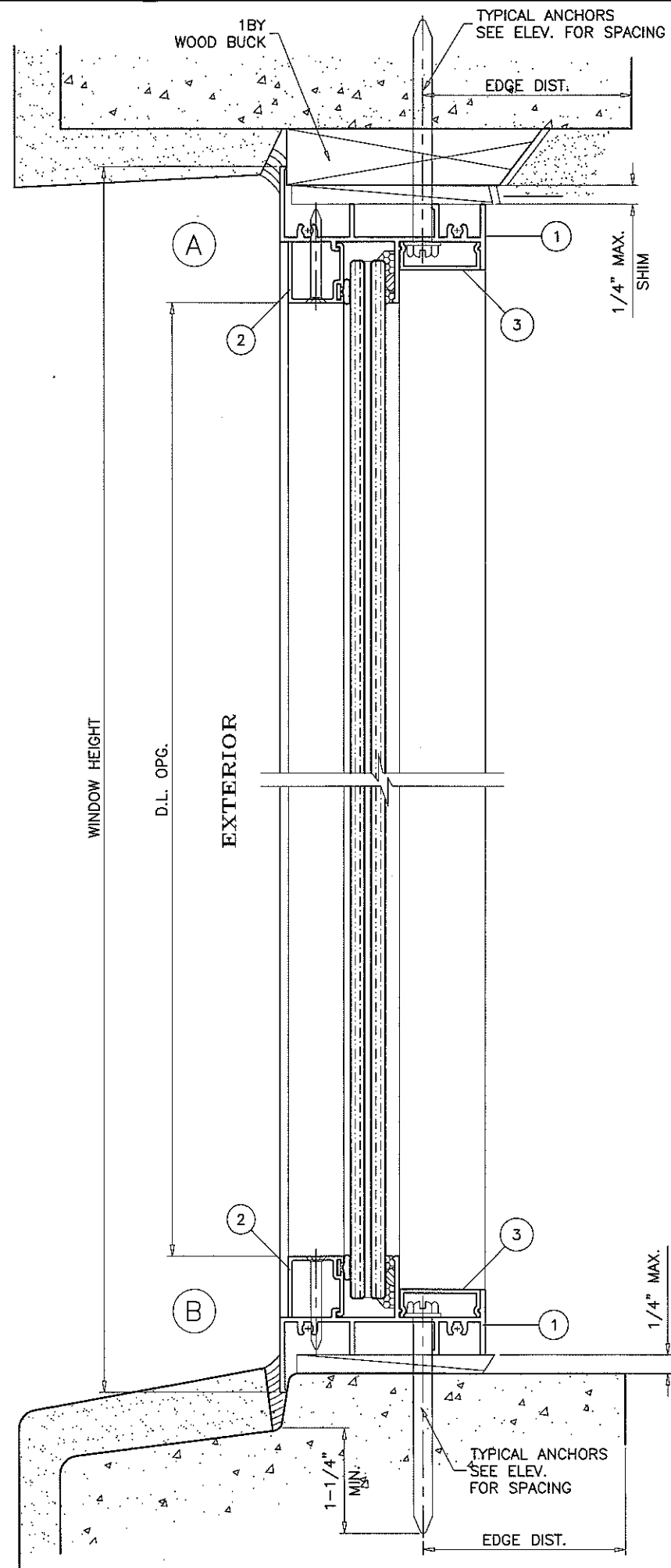

WOOD BUCKS AND METAL STRUCTURE NOT BY ECO WDW. MUST SUSTAIN LOADS IMPOSED BY GLAZING SYSTEM AND TRANSFER THEM TO THE BUILDING STRUCTURE.

TYPICAL ANCHORS: SEE ELEV. FOR SPACING
 1/4" DIA. ULTRACON BY 'ELCO' (Fu=177 KSI, Fy=155 KSI)
 INTO 2BY WOOD BUCKS OR WOOD STRUCTURES
 1-1/2" MIN. PENETRATION INTO WOOD (HEAD/SILL/JAMBS)
 THRU 1BY BUCKS INTO CONC. OR BLOCKS
 1-1/4" MIN. EMBED INTO CONCRETE (HEAD/SILL/JAMBS)
 1-1/4" MIN. EMBED INTO BLOCKS (JAMBS)
 DIRECTLY INTO CONCRETE OR BLOCKS
 1-1/4" MIN. EMBED INTO CONCRETE (HEAD/SILL/JAMBS)
 1-1/4" MIN. EMBED INTO BLOCKS (JAMBS)
 #14 SMS OR SELF DRILLING SCREWS (GRADE 2 CRS)
 INTO MIAMI-DADE COUNTY APPROVED MULLIONS OR
 INTO METAL STRUCTURES (HEAD/SILL/JAMBS)
 (3) THREADS MIN. PENETRATION BEYOND SUBSTRATE
 ALUMINUM: 1/8" THK. MIN. (6063-T5 MIN.)
 STEEL: 1/8" THK. MIN. (Fy = 36 KSI MIN.)
 (STEEL IN CONTACT WITH ALUMINUM TO BE PLATED OR PAINTED)
TYPICAL EDGE DISTANCE
 INTO CONCRETE AND MASONRY = 2-1/2" MIN.
 INTO WOOD STRUCTURE = 1" MIN.
 INTO METAL STRUCTURE = 3/4" MIN.
 WOOD AT HEAD, SILL OR JAMBS SG = 0.55 MIN.
 CONCRETE AT HEAD, SILL OR JAMBS f'c = 3000 PSI MIN.
 C-90 HOLLOW/FILLED BLOCK AT JAMBS f'm = 2000 PSI MIN.

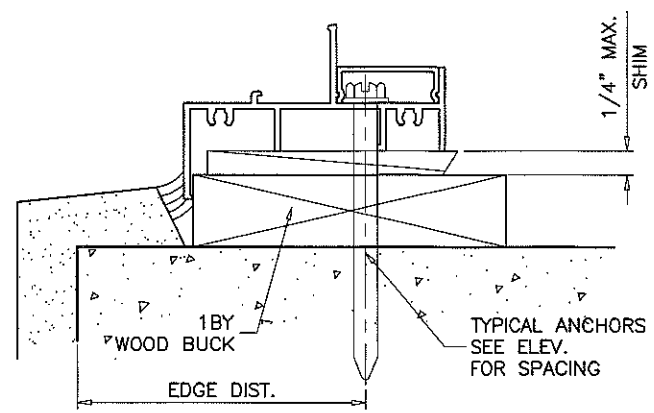

SEALANT:
 ALL JOINTS AND FRAME CONNECTIONS SEALED WITH JOINT SEALER.

PRODUCT REVISED
 as complying with the Florida
 Building Code
 Acceptance No 17-1102-20
 Expiration Date 06/12/2019
 By Sifang Zhao
 Miami Dade Product Control

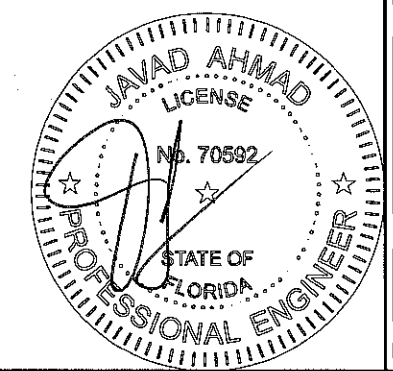

af c
AL-FAROOQ CORPORATION
 ENGINEERS & PRODUCT DEVELOPMENT
 9360 SUNSET DRIVE, SUITE 220
 MIAMI, FLORIDA 33173 (C.A.N. 3638)
 TEL. (305) 264-8100 FAX (305) 262-6978
 COMP-ANL W09-20ECO

ECO-GUARD SERIES-300 ALUM FIXED WDW. (L.M.I.)
ECO WINDOW SYSTEMS, LLC.
 8502 N.W. 80th STREET
 MEDLEY, FL. 33166
 TEL. (305) 885-5299 FAX (305) 885-5902

no	date	by	description
A	05.18.09		NO CHANGE THIS SHEET
B	01.30.12		NO CHANGE THIS SHEET
C	01.11.13		MANUF. ADDRESS REV.
D	07.08.15		UPDATED TO 2014 FBC
E	10.19.17		UPDATED TO 2017 FBC

date: 03-23-09
 scale: 1/2" = 1"
 dr. by: TARIQ
 chk. by:

drawing no.
W09-20
 sheet 3 of 5

ITEM #	PART #	REQD.	DESCRIPTION	MATERIAL	MANF./SUPPLIER/REMARKS
1	FY301	2	FRAME HEAD/SILL/JAMB	6063-T6	-
2	FY302	AS REQD.	GLAZING BEAD- 7/16" GLASS	6063-T6	-
3	FY303	AS REQD.	ANCHOR COVER	6063-T5	-
4	E203	AS REQD.	GLAZING BEAD BULB	NEOPRENE	ULTRAFAB
5	FLB-50	1	GLASS SPACER - 1/8" HIGH	SILICONE	FRANK LOWE
6	#10 x 1"	8	FRAME ASSEMBLY SCREWS	CRS	PH SMS
7	FY120	-	FLUSH FRAME ADAPTER	6063-T6	OPTIONAL
8	-	2/ LITE	SETTING BLOCK	EPDM	DUROMETER 85±5 SHORE A

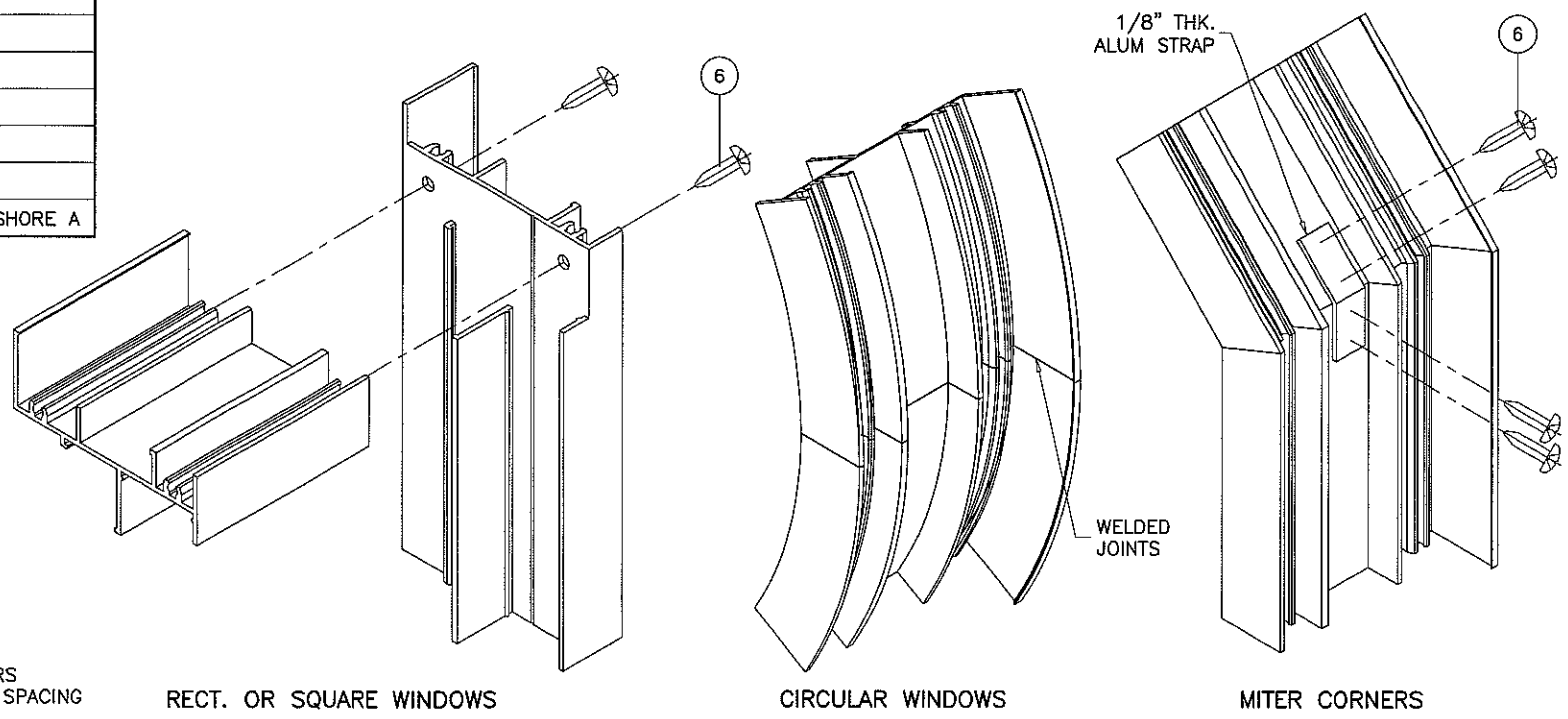

RECT. OR SQUARE WINDOWS

CIRCULAR WINDOWS

MITER CORNERS

CORNER DETAILS

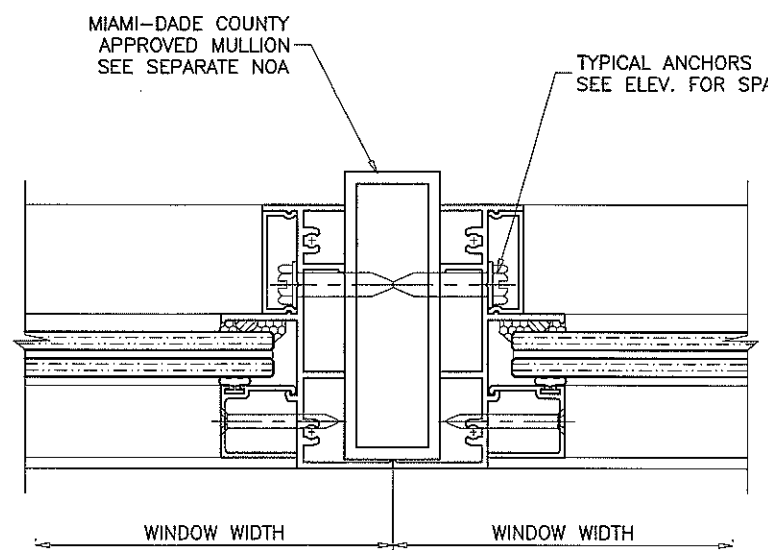

TYPICAL ANCHORS
SEE ELEV. FOR SPACING

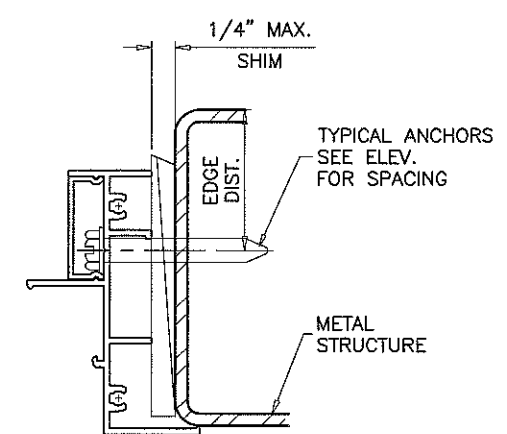
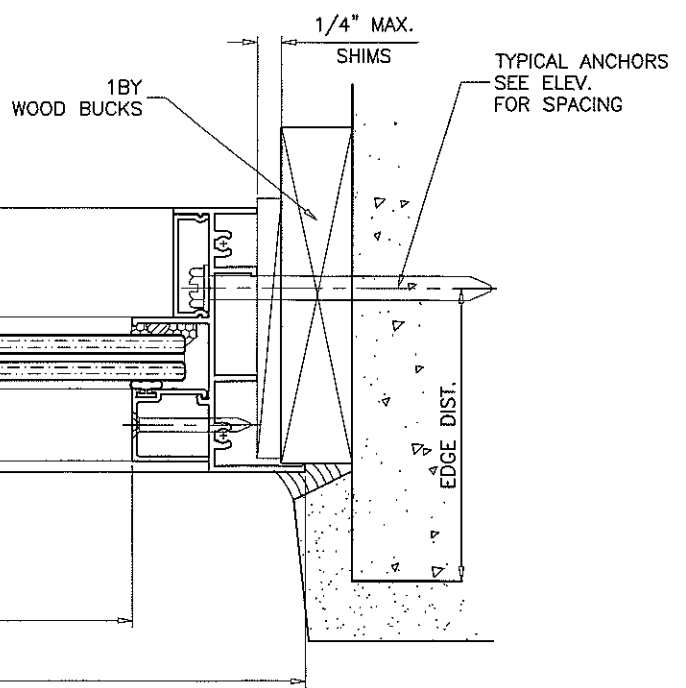
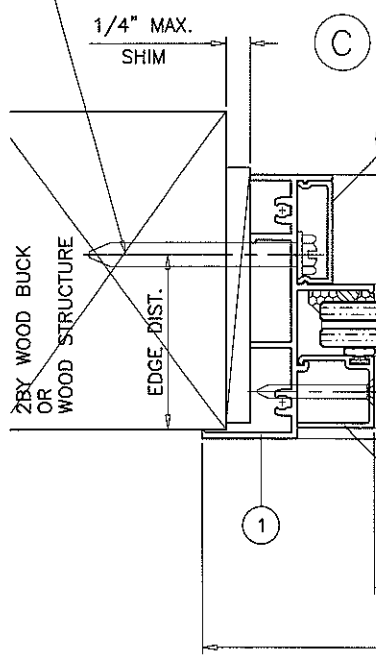

EXTERIOR
D.L. OPG.
WINDOW WIDTH

PRODUCT REVISED
as complying with the Florida
Building Code
Acceptance No 11-1102.20
Expiration Date 06/12/2019
By Sifang zhao
Miami Dade Product Control

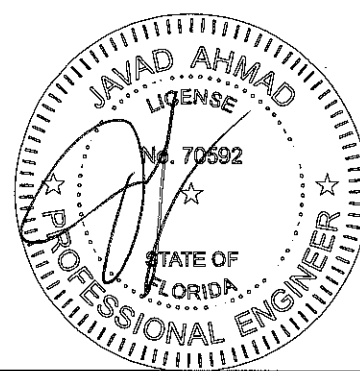

af c
AL-FAROOQ CORPORATION
 ENGINEERS & PRODUCT DEVELOPMENT
 9360 SUNSET DRIVE, SUITE 220 (C.A.N. 3638)
 MIAMI, FLORIDA 33173
 TEL. (305) 264-8100 FAX (305) 262-6978
 COMP-ANL W09-20ECO

ECO-GUARD SERIES-300 ALUM FIXED WDW. (L.M.I.)
ECO WINDOW SYSTEMS, LLC.
 8502 N.W. 80th STREET
 MEDLEY, FL. 33166
 TEL. (305) 885-5299 FAX (305) 885-5902

no	date	by	description
A	05.18.09		NO CHANGE THIS SHEET
B	01.30.12		NO CHANGE THIS SHEET
C	01.11.13		MANUF. ADDRESS REV.
D	07.08.15		UPDATED TO 2014 FBC
E	10.19.17		UPDATED TO 2017 FBC

date:	03-23-09
scale:	1/2" = 1"
dr. by:	TARIQ
chk. by:	

drawing no.
W09-20
sheet 4 of 5

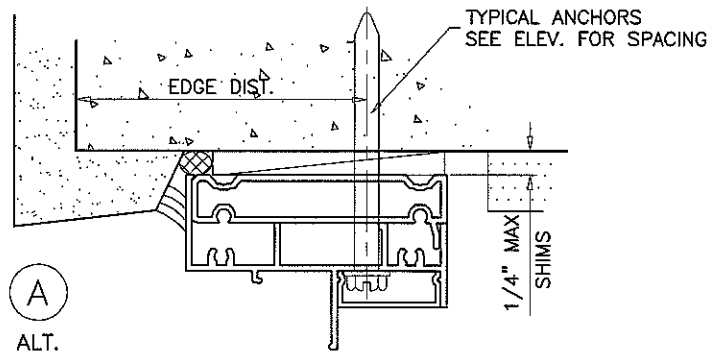

A
ALT.

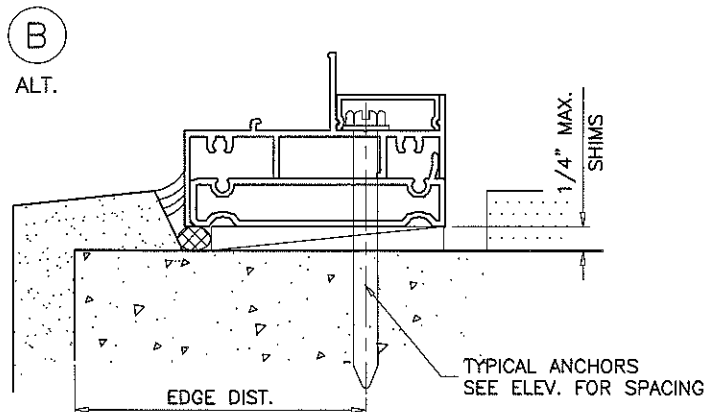
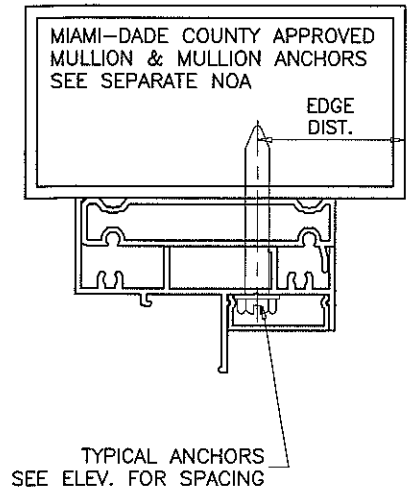
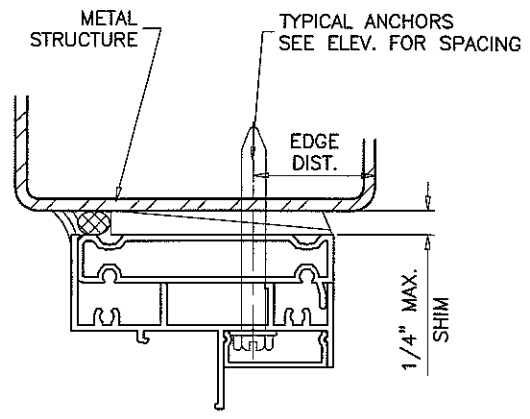

B
ALT.

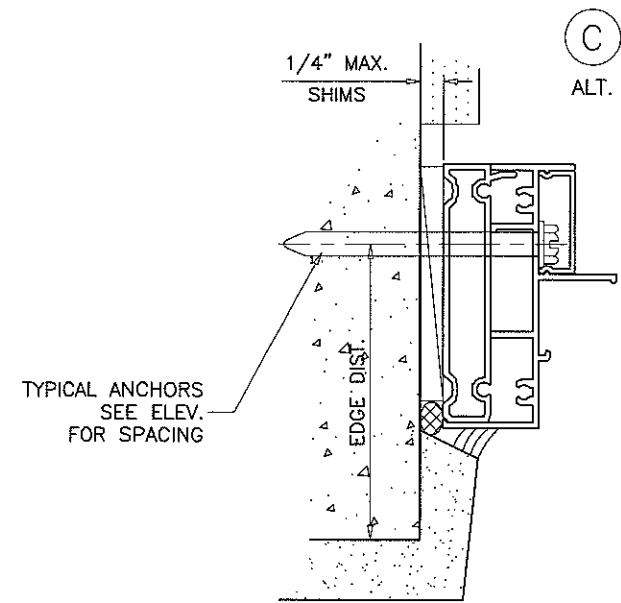

C
ALT.

INSTALLATION DETAILS WITH FLUSH FRAME ADAPTER

PRODUCT REVISED
as complying with the Florida
Building Code
Acceptance No 17-1102.20
Expiration Date 06/11/2019
By Sifang Zhao
Miami Dade Product Control

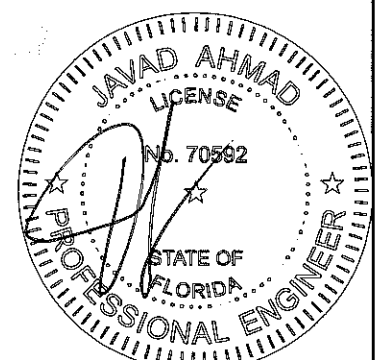

af c
AL-FAROOQ CORPORATION
ENGINEERS & PRODUCT DEVELOPMENT
9360 SUNSET DRIVE, SUITE 220
MIAMI, FLORIDA 33173 (C.A.N. 3538)
TEL. (305) 264-8100 FAX. (305) 262-6978
COMP-ANL\W09-20ECO

ECO-GUARD SERIES-300 ALUM FIXED WDW. (L.M.I.)
ECO WINDOW SYSTEMS, LLC.
8502 N.W. 80th STREET
MEDLEY, FL. 33166
TEL. (305) 885-5299 FAX (305) 885-5902

revisions:

no	date	by	description
A	05.18.09		NO CHANGE THIS SHEET
B	01.30.12		NO CHANGE THIS SHEET
C	01.11.13		MANUF. ADDRESS REV.
D	07.08.15		NO CHANGE THIS SHEET
E	10.19.17		UPDATED TO 2017 FBC

date: 03-23-09
scale: 1/2" = 1"
dr. by: TARIQ
chk. by:

drawing no.
W09-20
sheet 5 of 5