



DEPARTMENT OF REGULATORY AND ECONOMIC RESOURCES (RER)
BOARD AND CODE ADMINISTRATION DIVISION

MIAMI-DADE COUNTY
PRODUCT CONTROL SECTION

11805 SW 26 Street, Room 208
T (786) 315-2590 F (786) 315-2599

NOTICE OF ACCEPTANCE (NOA)

www.miamidade.gov/economy

PGT Industries, Inc.
1070 Technology Drive
North Venice, FL 34275

SCOPE:

This NOA is being issued under the applicable rules and regulations governing the use of construction materials. The documentation submitted has been reviewed and accepted by Miami-Dade County RER - Product Control Section to be used in Miami Dade County and other areas where allowed by the Authority Having Jurisdiction (AHJ).

This NOA shall not be valid after the expiration date stated below. The Miami-Dade County Product Control Section (In Miami-Dade County) and/or the AHJ (in areas other than Miami-Dade County) reserve the right to have this product or material tested for quality assurance purposes. If this product or material fails to perform in the accepted manner, the manufacturer will incur the expense of such testing and the AHJ may immediately revoke, modify, or suspend the use of such product or material within their jurisdiction. RER reserves the right to revoke this acceptance, if it is determined by Miami-Dade County Product Control Section that this product or material fails to meet the requirements of the applicable building code.

This product is approved as described herein, and has been designed to comply with the Florida Building Code, including the High Velocity Hurricane Zone.-

DESCRIPTION: Series "SH7600A" Aluminum Single Hung Window – N.I.

APPROVAL DOCUMENT: Drawing No. **7600NOA-1**, titled "Aluminum Single Hung Install (NI)", sheets 1 through 12 of 12, dated 04/01/18, prepared by manufacturer, signed and sealed by Anthony Lynn Miller, P.E., bearing the Miami-Dade County Product Control Approval stamp with the Notice of Acceptance number and approval date by the Miami-Dade County Product Control Section.

MISSILE IMPACT RATING: None

LABELING: Each unit shall bear a permanent label with the manufacturer's name or logo, city, state, model/series, and following statement: "Miami-Dade County Product Control Approved", unless otherwise noted herein.

RENEWAL of this NOA shall be considered after a renewal application has been filed and there has been no change in the applicable building code negatively affecting the performance of this product.

TERMINATION of this NOA will occur after the expiration date or if there has been a revision or change in the materials, use, and/or manufacture of the product or process. Misuse of this NOA as an endorsement of any product, for sales, advertising or any other purposes shall automatically terminate this NOA. Failure to comply with any section of this NOA shall be cause for termination and removal of NOA.

ADVERTISEMENT: The NOA number preceded by the words Miami-Dade County, Florida, and followed by the expiration date may be displayed in advertising literature. If any portion of the NOA is displayed, then it shall be done in its entirety.

INSPECTION: A copy of this entire NOA shall be provided to the user by the manufacturer or its distributors and shall be available for inspection at the job site at the request of the Building Official.

This NOA consists of this page 1 and evidence pages E-1 and E-2, as well as approval document mentioned above.

The submitted documentation was reviewed by **Manuel Perez, P.E.**



MP
8/16/18

NOA No. 18-0430.07
Expiration Date: August 23, 2023
Approval Date: August 23, 2018
Page 1

NOTICE OF ACCEPTANCE: EVIDENCE SUBMITTED

A. DRAWINGS

1. Manufacturer's die drawings and sections.
2. Drawing No. **7600NOA-1**, titled "Aluminum Single Hung Install (NI), sheets 1 through 12 of 12, dated 04/01/18, prepared by manufacturer, signed and sealed by Anthony Lynn Miller, P.E.

B. TESTS

1. Test reports on:
 - 1) Air Infiltration Test, per FBC, TAS 202-94
 - 2) Uniform Static Air Pressure Test, Loading per FBC, TAS 202-94
 - 3) Water Resistance Test, per FBC, TAS 202-94
 - 4) Large Missile Impact Test per FBC, TAS 201-94
 - 5) Cyclic Wind Pressure Loading per FBC, TAS 203-94
 - 6) Forced Entry Test, per FBC 2411.3.2.1, and TAS 202-94along with marked-up drawings and installation diagram of an aluminum single hung window, prepared by Fenestration Testing Laboratory, Inc., Test Report No. **FTL-18-7835.1**, dated 04/03/18, signed and sealed by Idalmis Ortega, P.E.
2. Test reports on:
 - 1) Air Infiltration Test, per FBC, TAS 202-94
 - 2) Uniform Static Air Pressure Test, Loading per FBC, TAS 202-94
 - 3) Water Resistance Test, per FBC, TAS 202-94
 - 4) Large Missile Impact Test per FBC, TAS 201-94
 - 5) Cyclic Wind Pressure Loading per FBC, TAS 203-94
 - 6) Forced Entry Test, per FBC 2411.3.2.1, and TAS 202-94along with marked-up drawings and installation diagram of an aluminum single hung window, prepared by Fenestration Testing Laboratory, Inc., Test Reports No. **FTL-18-7835.2**, dated 05/04/18, signed and sealed by Idalmis Ortega, P.E.

C. CALCULATIONS

1. Anchor verification calculations and structural analysis, complying with **FBC 6th Edition (2017)**, dated 04/23/18, prepared by manufacturer, signed and sealed by Anthony Lynn Miller, P.E.
2. Glazing complies with **ASTM E1300-09**

D. QUALITY ASSURANCE

1. Miami-Dade Department of Regulatory and Economic Resources (RER).

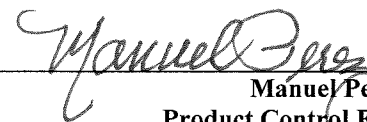

Manuel Perez, P.E.
Product Control Examiner
NOA No. 18-0430.07

Expiration Date: August 23, 2023

Approval Date: August 23, 2018

NOTICE OF ACCEPTANCE: EVIDENCE SUBMITTED

E. MATERIAL CERTIFICATIONS

1. None.

F. STATEMENTS

1. Statement letter of conformance to **FBC 6th Edition (2017)**, dated April 24, 2018, issued by manufacturer, signed and sealed by Anthony Lynn Miller, P.E.
2. Statement letter of no financial interest, dated April 24, 2018, issued by manufacturer, signed and sealed by Anthony Lynn Miller, P.E.
3. Proposal No. **18-0005R** issued by the Product Control Section, dated 01/16/18, signed by Manuel Perez, P.E

G. OTHERS

1. None.



Manuel Perez, P.E.
Product Control Examiner

NOA No. 18-0430.07

Expiration Date: August 23, 2023

Approval Date: August 23, 2018

SERIES SH7600A NON-IMPACT RESISTANT SINGLE HUNG WINDOW

- THIS PRODUCT HAS BEEN DESIGNED & TESTED TO COMPLY WITH THE REQUIREMENTS OF THE FLORIDA BUILDING CODE, INCLUDING THE HIGH VELOCITY HURRICANE ZONE (HVHZ).
- SHUTTERS ARE REQUIRED WHEN USED IN WIND-BORNE DEBRIS REGIONS.
- FOR MASONRY APPLICATIONS IN MIAMI-DADE COUNTY, USE ONLY MIAMI-DADE COUNTY APPROVED MASONRY ANCHORS. MATERIALS USED FOR ANCHOR EVALUATIONS WERE SOUTHERN PINE, ASTM C90 CONCRETE MASONRY UNITS AND CONCRETE WITH MIN. KSI PER ANCHOR TYPE.
- ALL WOOD BUCKS LESS THAN 1-1/2" THICK ARE TO BE CONSIDERED 1X INSTALLATIONS. 1X WOOD BUCKS ARE OPTIONAL IF UNIT IS INSTALLED DIRECTLY TO SUBSTRATE. WOOD BUCKS DEPICTED AS 2X ARE 1-1/2" THICK OR GREATER. 1X AND 2X BUCKS (WHEN USED) SHALL BE DESIGNED AND SECURED TO PROPERLY TRANSFER LOADS TO THE STRUCTURE. WOOD BUCK DESIGN AND INSTALLATION IS THE RESPONSIBILITY OF THE ENGINEER, (EOR) OR ARCHITECT OF RECORD, (AOR).
- ANCHOR EMBEDMENT TO BASE MATERIAL SHALL BE BEYOND WALL DRESSING OR STUCCO. USE ANCHORS OF SUFFICIENT LENGTH TO ACHIEVE REQUIRED MIN. EMBEDMENT. INSTALLATION ANCHORS SHOULD BE SEALED. OVERALL SEALING/FLASHING STRATEGY FOR WATER RESISTANCE OF INSTALLATION SHALL BE DONE BY OTHERS AND IS BEYOND THE SCOPE OF THESE INSTRUCTIONS.
- 1/4" MAX. SHIMS ARE REQUIRED AT EACH ANCHOR LOCATION WHERE THE PRODUCT IS NOT FLUSH TO THE SUBSTRATE. USE SHIMS CAPABLE OF TRANSFERRING APPLIED LOADS.
- DESIGN PRESSURES:
 - NEGATIVE DESIGN LOADS BASED ON STRUCTURAL TESTING AND GLASS PER ASTM E1300.
 - POSITIVE DESIGN LOADS BASED ON WATER TEST PRESSURE, STRUCTURAL TESTING AND GLASS PER ASTM E1300.
 - DESIGN LOADS ARE BASED ON ALLOWABLE STRESS DESIGN, ASD.
- THE ANCHORAGE METHODS SHOWN HAVE BEEN DESIGNED TO RESIST THE WINDLOADS CORRESPONDING TO THE REQUIRED DESIGN PRESSURE. THE 33-1/3% STRESS INCREASE HAS NOT BEEN USED IN THE DESIGN OF THIS PRODUCT. THE 1.6 LOAD DURATION FACTOR WAS USED FOR THE EVALUATION OF ANCHORS INTO WOOD. ANCHORS THAT COME INTO CONTACT WITH OTHER DISSIMILAR MATERIALS SHALL MEET THE REQUIREMENTS OF THE FLORIDA BUILDING CODE FOR CORROSION RESISTANCE.
- METAL SUBSTRATE TO MEET MIN. STRENGTH AND THICKNESS REQUIREMENTS PER CURRENT FLORIDA BUILDING CODE AND TO BE REVIEWED BY THE AUTHORITY HAVING JURISDICTION.
- REFERENCES: TEST REPORTS FTL 18-7835.1 & 18-7835.2; ELCO ULTRACON NOA; ELCO CRETEFLEX NOA; NATIONAL DESIGN SPECIFICATION FOR WOOD CONSTRUCTION, ANSI/AF&PA NDS & ALUMINUM DESIGN MANUAL
- APPLICABLE EGRESS REQUIREMENTS TO BE REVIEWED BY BUILDING OFFICIAL.

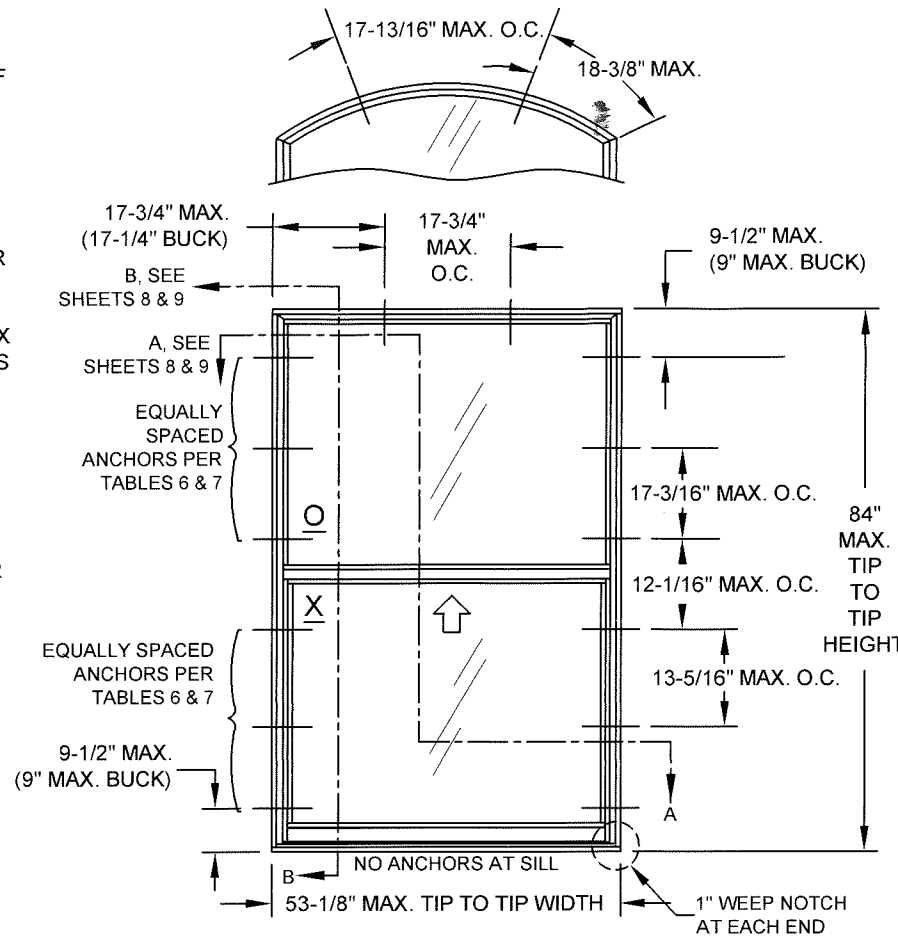

ELEVATION FOR TYP. FLANGE FRAME SHOWN WITH EQUAL-LITE CONFIGURATION

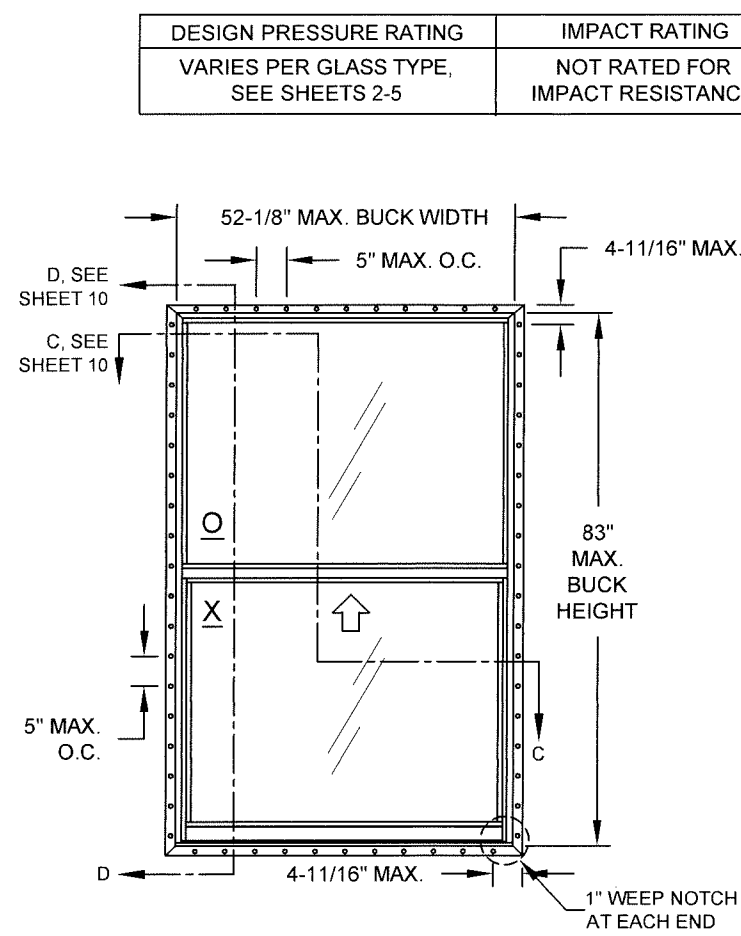

ELEVATION FOR TYP. FIN FRAME SHOWN WITH EQUAL-LITE CONFIGURATION

DESIGN PRESSURE RATING VARIES PER GLASS TYPE, SEE SHEETS 2-5	IMPACT RATING NOT RATED FOR IMPACT RESISTANCE
--------------------------------------------------------------------	-----------------------------------------------------

TABLE 1: ALLOWABLE GLASS TYPES

Glass Type	Description (Listed from Exterior to Interior)	DP Table #
1	1/8" Annealed	2
2	13/16" IG: 1/8" Annealed Cap, Airspace, 1/8" Annealed	3
3	3/16" Annealed	3
4	13/16" IG: 3/16" Annealed Cap, Airspace, 3/16" Annealed	4
5	1/8" Tempered	5
6	13/16" IG: 1/8" Tempered Cap, Airspace, 1/8" Tempered	5
7	3/16" Tempered	5
8	13/16" IG: 3/16" Tempered Cap, Airspace, 3/16" Tempered	5

GENERAL NOTES.....	1
ELEVATIONS.....	1
DESIGN PRESSURES / GLAZING DETAILS.....	2-5
ANCHOR QUANTITIES.....	6-7
INSTALLATION, FLANGE.....	8
INSTALLATION, EQUAL LEG.....	9
INSTALLATION, INTEGRAL FIN.....	10
EXTRUSION PROFILES.....	11
ASSEMBLY & PARTS LIST.....	12

CODES / STANDARDS USED:

- 2017 FLORIDA BUILDING CODE (FBC), 6TH EDITION
- ASTM E1300-09
- ANSI/AF&PA NDS-2015 FOR WOOD CONSTRUCTION
- ALUMINUM DESIGN MANUAL, ADM-2015
- AISI S100-12
- AISC 360-10

FIGURE A: ALLOWABLE SASH CONFIGURATIONS AND SHAPES

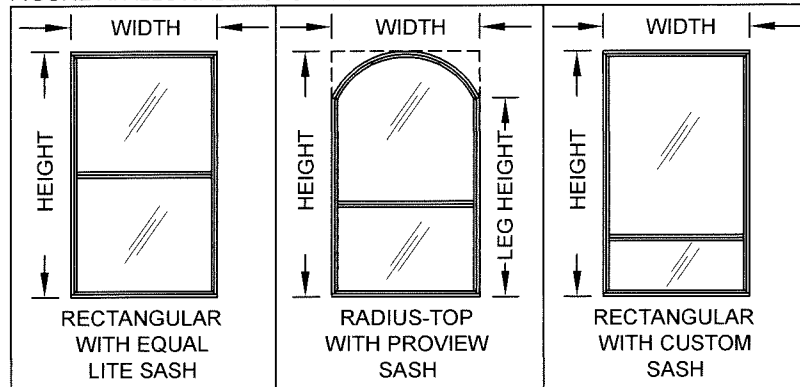

ALL SHAPES WITH ALL SASH CONFIGURATIONS ARE APPROVED. SHAPES MAY BE USED BY INSCRIBING THE SHAPE IN A BLOCK AND OBTAINING DESIGN PRESSURES AND ANCHORAGE FOR THAT BLOCK SIZE FROM THE TABLES ON THE FOLLOWING SHEETS.

USER INSTRUCTIONS:

- DETERMINE THE SITE SPECIFIC, WINDOW OPENING'S DESIGN PRESSURE REQUIREMENT FROM ASCE 7.
- KNOWING YOUR GLAZING OPTION (TABLE 1), WINDOW CONFIGURATION AND SIZE, DETERMINE YOUR WINDOW'S DESIGN PRESSURE FROM TABLES 2-5. IT MUST EQUAL OR EXCEED THE DESIGN PRESSURE REQUIREMENT FOR THE WINDOW OPENING OBTAINED IN STEP 1.
- DETERMINE THE ANCHOR QUANTITY FROM TABLES 6 & 7.
- INSTALL AS PER SHEET 8 FOR FLANGE INSTALLATION, SHEET 9 FOR EQUAL LEG INSTALLATION OR SHEET 10 FOR INTEGRAL FIN INSTALLATION.

NOTE: DESIGN PRESSURE RATING DETERMINATION IS THE SAME PROCESS FOR ALL FRAME TYPES (FLANGE, INTEGRAL FIN OR EQUAL LEG/BOX).

Approved as complying with the Florida Building Code
Date: Aug. 13, 2018
NOA# 180430.07
Miami Dade Product Control

Manuel Perez

Revision:

1070 TECHNOLOGY DRIVE
N. VENICE, FL 34275
(941) 480-1600

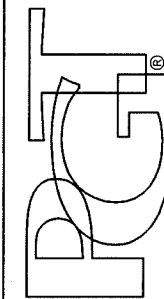

COPYRIGHT © 2018 PGT INDUSTRIES, INC.
ALL RIGHTS RESERVED

04/01/18

JENS ROSOWSKI

ALUMINUM SINGLE HUNG INSTALL. (NI)

GENERAL NOTES & ELEVATION

Date

By

Series Desc

Rev.

DWG

Sheet

No.

1 OF 12

7600NOA-1

SH7600A

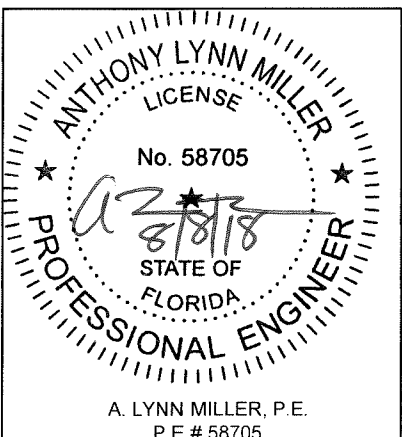

A. LYNN MILLER, P.E.
P.E.# 58705

TABLE 2:

Tip to Tip Height	Bottom Sash Description for Given Range	Sash Height Range (in)	Design Pressure (lbs/ft ²) for Glass Type 1															
			Tip to Tip Width															
			18"	25"	33"	37"	41"	45"	49"	53-1/8"								
24"	Equal-lite	12.464	+80.0	-130.0	+80.0	-130.0	+80.0	-130.0	+80.0	-130.0	+80.0	-127.1	+80.0	-113.8	+80.0	-103.1	+80.0	-93.9
	Equal-lite	15.964	+80.0	-130.0	+80.0	-130.0	+80.0	-104.0	+80.0	-95.5	+80.0	-89.1	+80.0	-84.2	+80.0	-81.4	+74.8	-74.8
31"	Standard Preview	12.994 - 15.963	+80.0	-130.0	+80.0	-127.0	+80.0	-86.9	+76.0	-76.0	+66.7	-66.7	+60.7	-60.7	+57.2	-57.2	+53.5	-53.5
	Shortest	12.464 - 12.993	+80.0	-130.0	+80.0	-124.0	+80.0	-84.0	+73.8	-73.8	+63.2	-63.2	+57.2	-57.2	+52.4	-52.4	+49.1	-49.1
38-3/8"	Equal-lite	19.652	+80.0	-130.0	+80.0	-124.0	+80.0	-84.0	+73.8	-73.8	+63.2	-63.2	+57.2	-57.2	+52.4	-52.4	+49.1	-49.1
	Standard Preview	15.944 - 19.651	+80.0	-130.0	+80.0	-110.0	+80.0	-80.6	+70.3	-70.3	+60.2	-60.2	+52.2	-52.2	+46.8	-46.8	+41.0	-41.0
	Custom Size	15.131 - 15.943	+80.0	-130.0	+80.0	-102.0	+78.2	-78.2	+68.7	-68.7	+59.3	-59.3	+51.7	-51.7	+46.2	-46.2	+40.0	-40.0
	Custom Size	14.131 - 15.130	+80.0	-124.0	+80.0	-98.5	+77.1	-77.1	+67.4	-67.4	+58.9	-58.9	+51.5	-51.5	+46.1	-46.1	+39.9	-39.9
	Shortest	12.464 - 14.130	+80.0	-118.0	+80.0	-95.2	+75.4	-75.4	+66.1	-66.1	+58.5	-58.5	+51.3	-51.3	+46.1	-46.1	+40.0	-40.0
45"	Equal-lite	22.964	+80.0	-130.0	+80.0	-110.0	+80.0	-80.6	+70.3	-70.3	+60.2	-60.2	+52.2	-52.2	+46.8	-46.8	+41.0	-41.0
	Custom Size	20.131 - 22.963	+80.0	-124.0	+80.0	-98.5	+77.1	-77.1	+67.4	-67.4	+58.9	-58.9	+51.5	-51.5	+46.1	-46.1	+39.9	-39.9
	Standard Preview	18.594 - 20.130	+80.0	-118.0	+80.0	-95.2	+75.4	-75.4	+66.1	-66.1	+58.5	-58.5	+51.3	-51.3	+46.1	-46.1	+40.0	-40.0
	Custom Size	16.131 - 18.593	+80.0	-102.0	+80.0	-85.0	+69.9	-69.9	+62.1	-62.1	+55.7	-55.7	+50.4	-50.4	+45.3	-45.3	+40.0	-40.0
	Custom Size	15.131 - 16.130	+80.0	-98.0	+80.0	-81.9	+68.1	-68.1	+60.6	-60.6	+54.6	-54.6	+49.7	-49.7	+44.8	-44.8	+39.9	-39.9
	Custom Size	14.131 - 15.130	+80.0	-95.5	+79.4	-79.4	+66.4	-66.4	+59.2	-59.2	+53.6	-53.6	+48.7	-48.7	+44.3	-44.3	+39.7	-39.7
49"	Shortest	12.464 - 14.130	+80.0	-89.4	+74.6	-74.6	+62.1	-62.1	+56.3	-56.3	+51.1	-51.1	+46.7	-46.7	+42.7	-42.7	+38.6	-38.6
	Equal-lite	24.964	+80.0	-130.0	+80.0	-102.0	+78.2	-78.2	+68.7	-68.7	+59.3	-59.3	+51.7	-51.7	+46.2	-46.2	+40.0	-40.0
	Custom Size	22.131 - 24.963	+80.0	-112.0	+80.0	-92.0	+73.5	-73.5	+64.8	-64.8	+57.9	-57.9	+51.0	-51.0	+46.0	-46.0	+40.0	-40.0
	Standard Preview	20.194 - 22.130	+80.0	-102.0	+80.0	-85.0	+69.9	-69.9	+62.1	-62.1	+55.7	-55.7	+50.4	-50.4	+45.3	-45.3	+40.0	-40.0
	Custom Size	18.131 - 20.193	+80.0	-95.5	+79.4	-79.4	+66.4	-66.4	+59.2	-59.2	+53.6	-53.6	+48.7	-48.7	+44.3	-44.3	+39.7	-39.7
50-5/8"	Custom Size	16.131 - 18.130	+80.0	-89.4	+74.6	-74.6	+62.1	-62.1	+56.3	-56.3	+51.1	-51.1	+46.7	-46.7	+42.7	-42.7	+38.6	-38.6
	Custom Size	14.131 - 16.130	+80.0	-84.6	+69.5	-69.5	+59.2	-59.2	+53.7	-53.7	+48.8	-48.8	+44.8	-44.8	+40.9	-40.9	+37.6	-37.6
	Shortest	12.464 - 14.130	+80.0	-81.9	+64.0	-64.0	+56.4	-56.4	+51.0	-51.0	+46.6	-46.6	+42.3	-42.3	+39.4	-39.4	+36.0	-36.0
	Equal-lite	25.777	+80.0	-124.0	+80.0	-98.5	+77.1	-77.1	+67.4	-67.4	+58.9	-58.9	+51.5	-51.5	+46.1	-46.1	+39.9	-39.9
	Custom Size	24.131 - 25.776	+80.0	-112.0	+80.0	-92.0	+73.5	-73.5	+64.8	-64.8	+57.9	-57.9	+51.0	-51.0	+46.0	-46.0	+39.9	-39.9
63"	Standard Preview	20.844 - 24.130	+80.0	-98.0	+80.0	-81.9	+68.1	-68.1	+60.6	-60.6	+54.6	-54.6	+49.7	-49.7	+44.8	-44.8	+39.9	-39.9
	Custom Size	19.131 - 20.843	+80.0	-92.6	+77.0	-77.0	+64.1	-64.1	+57.7	-57.7	+52.3	-52.3	+47.7	-47.7	+43.8	-43.8	+39.2	-39.2
	Custom Size	16.131 - 19.130	+80.0	-84.6	+69.5	-69.5	+59.2	-59.2	+53.7	-53.7	+48.8	-48.8	+44.8	-44.8	+40.9	-40.9	+37.6	-37.6
	Shortest	13.089* - 16.130	+80.0	-80.6	+61.7	-61.7	+55.1	-55.1	+49.8	-49.8	+45.5	-45.5	+41.3	-41.3	+38.6	-38.6	+35.1	-35.1
	Equal-lite	31.964	+80.0	-95.5	+79.4	-79.4	+66.4	-66.4	+59.2	-59.2	+53.6	-53.6	+48.7	-48.7	+44.3	-44.3	+39.7	-39.7
69"	Custom Size	28.131 - 31.963	+80.0	-84.6	+69.5	-69.5	+59.2	-59.2	+53.7	-53.7	+48.8	-48.8	+44.8	-44.8	+40.9	-40.9	+37.6	-37.6
	Standard Preview	25.794 - 28.130	+80.0	-80.6	+61.7	-61.7	+55.1	-55.1	+49.8	-49.8	+45.5	-45.5	+41.3	-41.3	+38.6	-38.6	+35.1	-35.1
	Shortest	25.049* - 25.793	+80.0	-80.6	+61.7	-61.7	+55.1	-55.1	+49.8	-49.8	+45.5	-45.5	+41.3	-41.3	+38.6	-38.6	+35.1	-35.1
73"	Equal-lite	34.964	+80.0	-86.5	+72.2	-72.2	+60.6	-60.6	+55.0	-55.0	+49.9	-49.9	+45.8	-45.8	+41.7	-41.7	+38.1	-38.1
	Custom Size	33.131 - 34.963	+80.0	-83.1	+66.7	-66.7	+57.8	-57.8	+52.1	-52.1	+47.6	-47.6	+43.5	-43.5	+40.1	-40.1	+36.8	-36.8
	Shortest	31.049* - 33.130	+80.0	-80.6	+61.7	-61.7	+55.1	-55.1	+49.8	-49.8	+45.5	-45.5	+41.3	-41.3	+38.6	-38.6	+35.1	-35.1
76"	Equal-lite	36.964	+80.0	-83.1	+66.7	-66.7	+57.8	-57.8	+52.1	-52.1	+47.6	-47.6	+43.5	-43.5	+40.1	-40.1	+36.8	-36.8
	Custom Size	36.131 - 36.963	+80.0	-81.9	+64.0	-64.0	+56.4	-56.4	+51.0	-51.0	+46.6	-46.6	+42.3	-42.3	+39.4	-39.4	+36.0	-36.0
	Shortest	35.049* - 36.130	+80.0	-80.6	+61.7	-61.7	+55.1	-55.1	+49.8	-49.8	+45.5	-45.5	+41.3	-41.3	+38.6	-38.6	+35.1	-35.1
76"	Tallest	38.464*	+80.0	-80.6	+61.7	-61.7	+55.1	-55.1	+49.8	-49.8	+45.5	-45.5	+41.3	-41.3	+38.6	-38.6	+35.1	-35.1

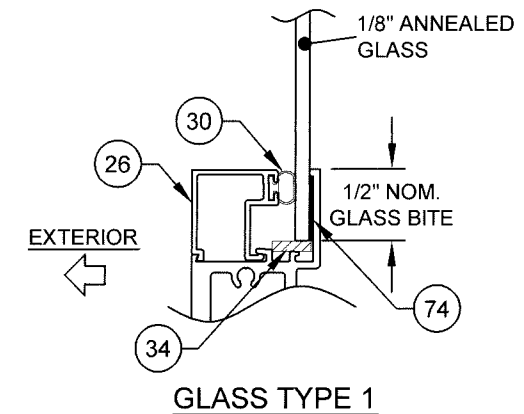

*MINIMUM SASH HEIGHT FOR FLANGED WINDOWS IS: TIP TO TIP HEIGHT - 37.536
 MINIMUM SASH HEIGHT FOR INTEGRAL FIN AND EQUAL LEG WINDOWS IS: BUCK HEIGHT - 36.536
 MINIMUM SASH HEIGHT FOR FLANGED, RADIUS TOP WINDOWS IS: TIP TO TIP HEIGHT - 37.951
 MINIMUM SASH HEIGHT FOR INTEGRAL FIN AND EQUAL LEG, RADIUS TOP WINDOWS IS: BUCK HEIGHT - 36.951

- 1) TIP TO TIP DIMENSIONS SHOWN. FOR INTEGRAL FIN AND EQUAL-LEG WINDOWS, SUBTRACT 1" FROM THE TIP TO TIP DIMENSION IN THE TABLE TO DETERMINE THE WINDOW SIZE.
- 2) FOR SIZES NOT SHOWN, ROUND UP TO THE NEXT AVAILABLE SIZE.
- 3) FOR RADIUS TOP WINDOWS, FIND THE SMALLEST WINDOW SIZE IN THE TABLE ABOVE WHICH THE RADIUS TOP WINDOW WILL COMPLETELY FIT WITHIN.
- 4) WINDOWS WITH THE LOW SILL OPTION ARE LIMITED TO A MAXIMUM POSITIVE DESIGN PRESSURE OF +65 PSF. NEGATIVE DESIGN PRESSURES ARE UNAFFECTED.

Approved as complying with the Florida Building Code
 Date: 12/23/2018
 NOA# 18-20426-07
 Manual Sign

Revision:

1070 TECHNOLOGY DRIVE
 N. VENICE, FL 34275
 (941) 480-1600

COPYRIGHT © 2018 PGT INDUSTRIES, INC.
 ALL RIGHTS RESERVED

PGT
 CERT. OF AUTH. #29296

ALUMINUM SINGLE HUNG INSTALL. (NI)
 DP TABLE

04/01/18
 JENS ROSOWSKI
 7600NOA-1

2 OF 12
 SH7600A

ANTHONY LYNN MILLER
 LICENSE
 No. 58705
 8/18/18
 STATE OF FLORIDA
 PROFESSIONAL ENGINEER
 A. LYNN MILLER, P.E.
 P.E.# 58705

TABLE 5:

Tip to Tip Height	Bottom Sash Description for Given Range	Sash Height Range (in)	Design Pressure (lbs/ft ²) for Glass Types 5-8															
			Tip to Tip Width															
			18"	25"	33"	37"	41"	45"	49"	53-1/8"	18"	25"	33"	37"	41"	45"	49"	53-1/8"
24"	Equal-lite	12.464	+80.0	-130.0	+80.0	-130.0	+80.0	-130.0	+80.0	-130.0	+80.0	-130.0	+80.0	-130.0	+80.0	-130.0	+80.0	-130.0
	Equal-lite	15.964	+80.0	-130.0	+80.0	-130.0	+80.0	-130.0	+80.0	-130.0	+80.0	-130.0	+80.0	-130.0	+80.0	-130.0	+80.0	-130.0
31"	Standard Preview	12.994 - 15.963	+80.0	-130.0	+80.0	-130.0	+80.0	-130.0	+80.0	-130.0	+80.0	-130.0	+80.0	-130.0	+80.0	-130.0	+80.0	-130.0
	Shortest	12.464 - 12.993	+80.0	-130.0	+80.0	-130.0	+80.0	-130.0	+80.0	-130.0	+80.0	-130.0	+80.0	-130.0	+80.0	-130.0	+80.0	-130.0
38-3/8"	Equal-lite	19.652	+80.0	-130.0	+80.0	-130.0	+80.0	-130.0	+80.0	-130.0	+80.0	-130.0	+80.0	-130.0	+80.0	-130.0	+80.0	-130.0
	Standard Preview	15.944 - 19.651	+80.0	-130.0	+80.0	-130.0	+80.0	-130.0	+80.0	-130.0	+80.0	-130.0	+80.0	-130.0	+80.0	-122.0	+80.0	-112.0
	Custom Size	15.131 - 15.943	+80.0	-130.0	+80.0	-130.0	+80.0	-130.0	+80.0	-130.0	+80.0	-130.0	+80.0	-130.0	+80.0	-130.0	+80.0	-130.0
	Custom Size	14.131 - 15.130	+80.0	-130.0	+80.0	-130.0	+80.0	-130.0	+80.0	-130.0	+80.0	-130.0	+80.0	-130.0	+80.0	-130.0	+80.0	-130.0
45"	Equal-lite	22.964	+80.0	-130.0	+80.0	-130.0	+80.0	-130.0	+80.0	-130.0	+80.0	-130.0	+80.0	-130.0	+80.0	-130.0	+80.0	-117.7
	Standard Preview	18.594 - 20.130	+80.0	-130.0	+80.0	-130.0	+80.0	-130.0	+80.0	-130.0	+80.0	-130.0	+80.0	-130.0	+80.0	-129.1	+80.0	-116.0
49"	Equal-lite	24.964	+80.0	-130.0	+80.0	-130.0	+80.0	-130.0	+80.0	-130.0	+80.0	-130.0	+80.0	-130.0	+80.0	-123.3	+80.0	-110.6
	Standard Preview	20.194 - 22.130	+80.0	-130.0	+80.0	-130.0	+80.0	-130.0	+80.0	-130.0	+80.0	-130.0	+80.0	-130.0	+80.0	-121.3	+80.0	-106.6
	Custom Size	18.131 - 20.193	+80.0	-130.0	+80.0	-130.0	+80.0	-130.0	+80.0	-130.0	+80.0	-130.0	+80.0	-130.0	+80.0	-120.8	+80.0	-108.1
	Shortest	12.464 - 14.130	+80.0	-130.0	+80.0	-130.0	+80.0	-130.0	+80.0	-130.0	+80.0	-130.0	+80.0	-130.0	+80.0	-129.2	+80.0	-114.9
50-5/8"	Equal-lite	25.777	+80.0	-130.0	+80.0	-130.0	+80.0	-130.0	+80.0	-130.0	+80.0	-130.0	+80.0	-130.0	+80.0	-120.6	+80.0	-108.1
	Standard Preview	20.844 - 24.130	+80.0	-130.0	+80.0	-130.0	+80.0	-130.0	+80.0	-130.0	+80.0	-130.0	+80.0	-130.0	+80.0	-116.7	+80.0	-104.3
	Custom Size	18.131 - 20.843	+80.0	-130.0	+80.0	-130.0	+80.0	-130.0	+80.0	-130.0	+80.0	-130.0	+80.0	-130.0	+80.0	-120.1	+80.0	-107.4
	Shortest	12.464 - 14.130	+80.0	-130.0	+80.0	-130.0	+80.0	-130.0	+80.0	-130.0	+80.0	-130.0	+80.0	-130.0	+80.0	-127.8	+80.0	-113.4
63"	Equal-lite	31.964	+80.0	-130.0	+80.0	-130.0	+80.0	-130.0	+80.0	-130.0	+80.0	-130.0	+80.0	-120.6	+80.0	-105.7	+76.2	-93.8
	Standard Preview	25.794 - 28.130	+80.0	-130.0	+80.0	-130.0	+80.0	-130.0	+80.0	-130.0	+80.0	-130.0	+80.0	-119.8	+80.0	-104.6	+75.2	-92.6
	Custom Size	24.131 - 25.793	+80.0	-130.0	+80.0	-130.0	+80.0	-130.0	+80.0	-130.0	+80.0	-130.0	+80.0	-121.8	+80.0	-106.3	+76.4	-94.0
	Shortest	13.194* - 16.130	+80.0	-130.0	+80.0	-130.0	+80.0	-130.0	+80.0	-130.0	+80.0	-130.0	+80.0	-129.2	+80.0	-118.8	+80.0	-103.5
76"	Equal-lite	38.464	+80.0	-130.0	+80.0	-130.0	+80.0	-130.0	+80.0	-130.0	+80.0	-130.0	+80.0	-112.5	+78.9	-97.1	+69.1	-85.1
	Standard Preview	30.994 - 34.130	+80.0	-130.0	+80.0	-130.0	+80.0	-130.0	+80.0	-130.0	+80.0	-130.0	+80.0	-113.0	+78.7	-96.9	+68.7	-84.5
	Custom Size	28.131 - 30.130	+80.0	-130.0	+80.0	-130.0	+80.0	-130.0	+80.0	-130.0	+80.0	-130.0	+80.0	-115.9	+80.0	-99.5	+70.4	-86.6
	Shortest	26.194* - 28.130	+80.0	-130.0	+80.0	-130.0	+80.0	-130.0	+80.0	-130.0	+80.0	-130.0	+80.0	-117.9	+80.0	-101.3	+71.5	-88.0
84"	Equal-lite	42.464	+80.0	-130.0	+80.0	-130.0	+80.0	-130.0	+80.0	-130.0	+80.0	-130.0	+80.0	-110.4	+76.5	-94.2	+66.5	-81.8
	Standard Preview	34.194* - 38.130	+80.0	-130.0	+80.0	-130.0	+80.0	-130.0	+80.0	-130.0	+80.0	-130.0	+80.0	-111.1	+76.8	-94.5	+66.3	-81.6

* MINIMUM SASH HEIGHT FOR FLANGED WINDOWS IS: TIP TO TIP HEIGHT - 49.391
 MINIMUM SASH HEIGHT FOR INTEGRAL FIN AND EQUAL LEG WINDOWS IS: BUCK HEIGHT - 48.391
 MINIMUM SASH HEIGHT FOR FLANGED, RADIUS TOP WINDOWS IS: TIP TO TIP HEIGHT - 49.806
 MINIMUM SASH HEIGHT FOR INTEGRAL FIN AND EQUAL LEG, RADIUS TOP WINDOWS IS: BUCK HEIGHT - 48.806

- 1) TIP TO TIP DIMENSIONS SHOWN. FOR INTEGRAL FIN AND EQUAL-LEG WINDOWS, SUBTRACT 1" FROM THE TIP TO TIP DIMENSION IN THE TABLE TO DETERMINE THE WINDOW SIZE.
- 2) FOR SIZES NOT SHOWN, ROUND UP TO THE NEXT AVAILABLE SIZE.
- 3) FOR RADIUS TOP WINDOWS, FIND THE SMALLEST WINDOW SIZE IN THE TABLE ABOVE WHICH THE RADIUS TOP WINDOW WILL COMPLETELY FIT WITHIN.
- 4) WINDOWS WITH THE LOW SILL OPTION ARE LIMITED TO A MAXIMUM POSITIVE DESIGN PRESSURE OF +65 PSF. NEGATIVE DESIGN PRESSURES ARE UNAFFECTED.

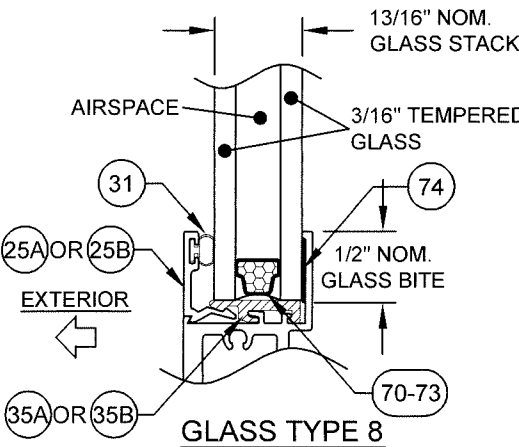
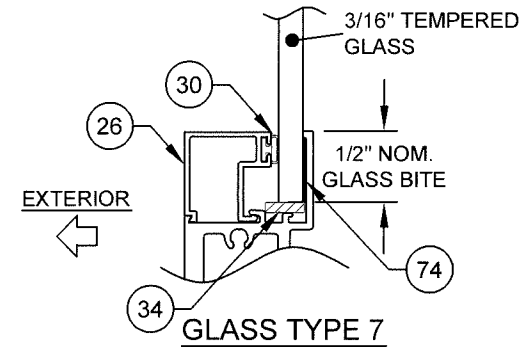
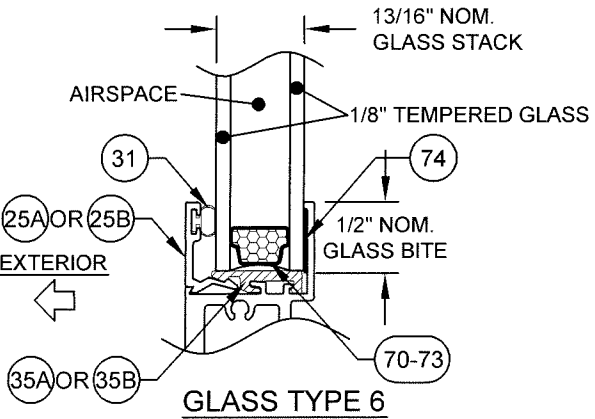
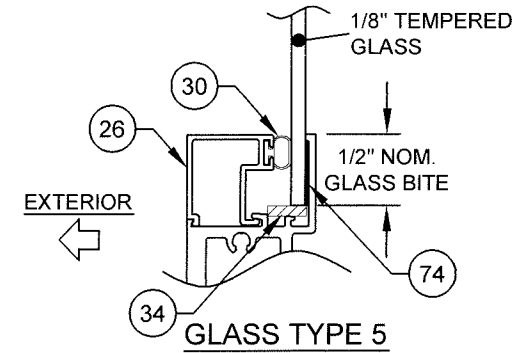

Approved as complying with the Florida Building Code
 Date: Aug. 23, 2018
 NOA# 18-0435-07
 Miami Date Product Control

Manuel Perez

1070 TECHNOLOGY DRIVE N. VENICE, FL 34275 (941) 480-1600	COPYRIGHT © 2018 PGT INDUSTRIES, INC. ALL RIGHTS RESERVED	Date	04/01/18	Rev.	
		By	JENS ROSOWSKI	DWC No.	7600NOA-1
CERT. OF AUTH. #29296 ALUMINUM SINGLE HUNG INSTALL. (NI)		DP TABLE		5 OF 12	
		Series	SH7600A	Sheet	

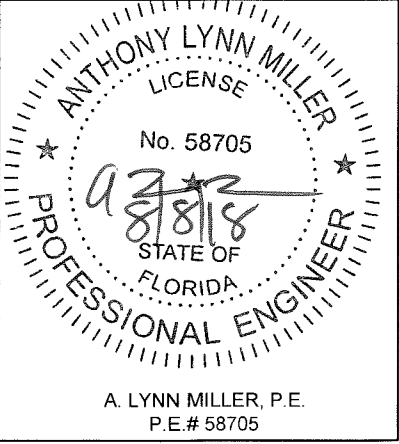

INSTALLATION DETAILS FOR FLANGE FRAMES

INSTALLATION OPTION 1
 ANCHORED THROUGH FRAME INTO 2X WOOD FRAME OR BUCKSTRIP. SEE NOTE 2, THIS SHEET.

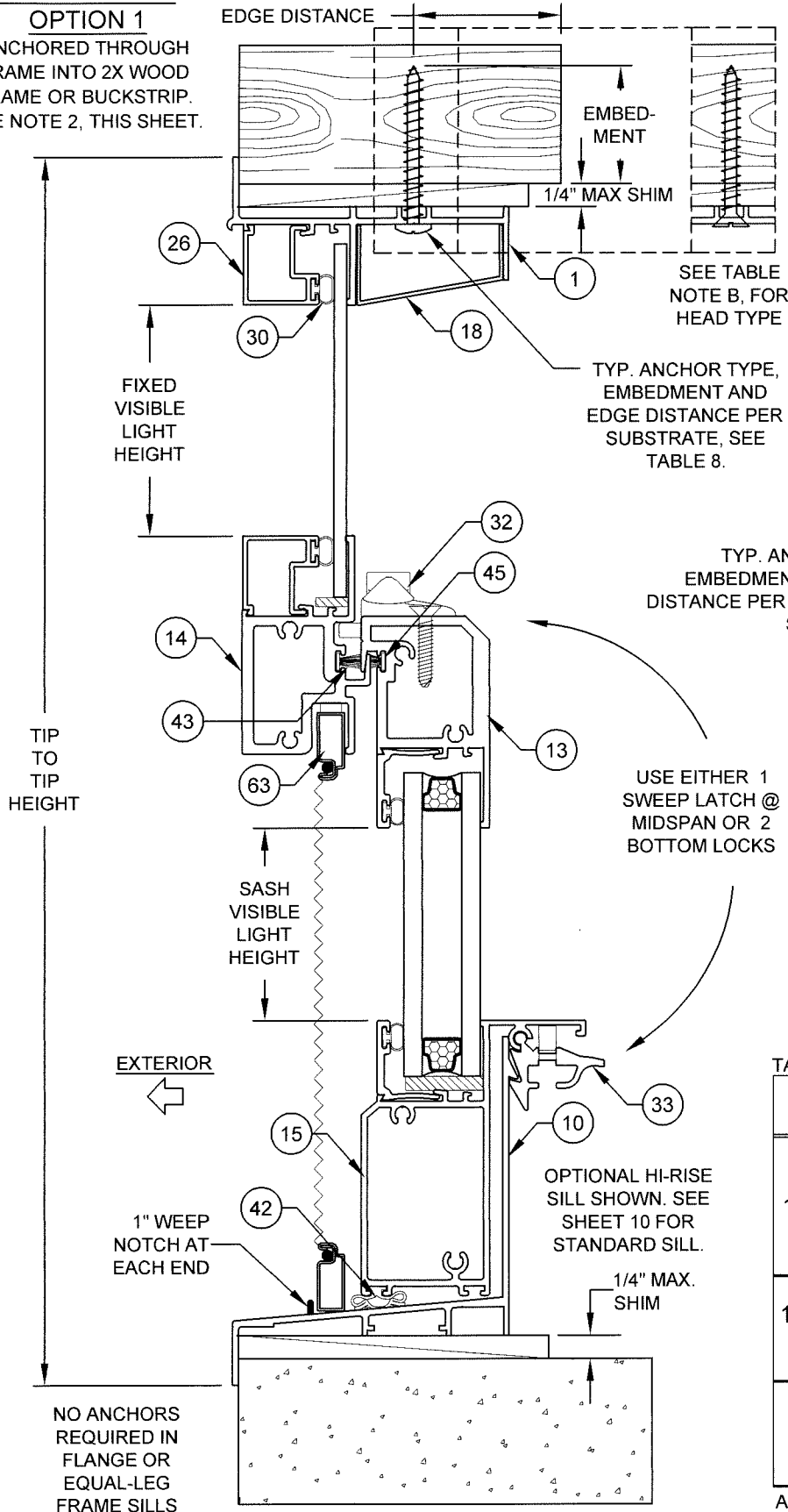

VERTICAL SECTION B-B

INSTALLATION OPTION 2
 ANCHORED THROUGH FRAME DIRECTLY INTO CONCRETE/CMU.

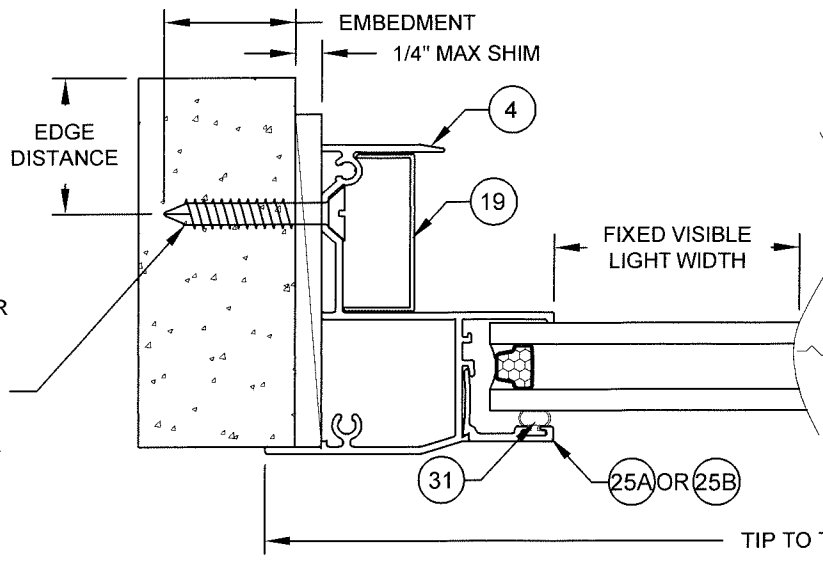

HORIZONTAL SECTION A-A

INSTALLATION OPTION 3
 ANCHORED THROUGH FRAME AND 1X BUCKSTRIP INTO CONCRETE/CMU. SEE NOTE 2, THIS SHEET.

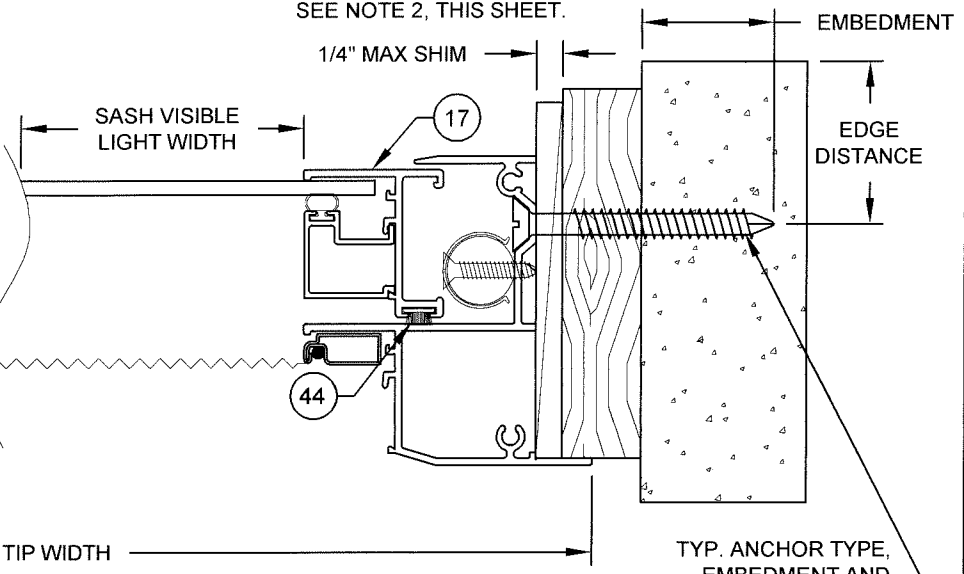

TYP. ANCHOR TYPE, EMBEDMENT AND EDGE DISTANCE PER SUBSTRATE, SEE TABLE 8.

TYP. ANCHOR TYPE, EMBEDMENT AND EDGE DISTANCE PER SUBSTRATE, SEE TABLE 8.

TYP. ANCHOR TYPE, EMBEDMENT AND EDGE DISTANCE PER SUBSTRATE, SEE TABLE 8.

USE EITHER 1 SWEEP LATCH @ MIDSPAN OR 2 BOTTOM LOCKS

OPTIONAL HI-RISE SILL SHOWN. SEE SHEET 10 FOR STANDARD SILL.

NO ANCHORS REQUIRED IN FLANGE OR EQUAL-LEG FRAME SILLS

TABLE 8:

Anchor	Substrate	Min. Edge Distance	Min. Embedment
#12 Steel, 18-8 or 410 SS Screw	P.T. Southern Pine (SG=0.55)	9/16"	1-3/8"
	Aluminum, 6063-T5 min.	3/8"	0.063"
	A36 Steel	3/8"	0.063"
1/4" 410 SS CreteFlex	Concrete (min. 3.35 ksi)	1"	1-3/4"
	UngROUTED CMU, (ASTM C-90)	2-1/2"	1-1/4"
	P.T. Southern Pine (SG=0.55)	1"	1-3/8"
1/4" Steel Ultracon	Concrete (min. 2.85 ksi)	1"	1-3/8"
	UngROUTED CMU, (ASTM C-90)	2-1/2"	1-1/4"
	P.T. Southern Pine (SG=0.55)	1"	1-3/8"

A) MIN. OF 3 THREADS BEYOND THE METAL SUBSTRATE.
 B) USE ONLY FLATHEAD ANCHORS IN JAMBS. PAN/HEX/FLAT HEAD TYPE IS ALLOWABLE FOR ANCHORS IN THE HEAD.
 C) "UNGRouted CMU" VALUES MAY BE USED FOR GRouted CMU APPLICATIONS.

DADE APPROVED MULLION, FBC COMPLIANT ALUMINUM/STEEL FRAMING OR STEEL STUD. MAY BE VERTICAL OR HORIZONTAL. SEE SUBSTRATE PROPERTIES, TABLE 8.

INSTALLATION OPTION 4
 ANCHORED THROUGH FRAME INTO METAL

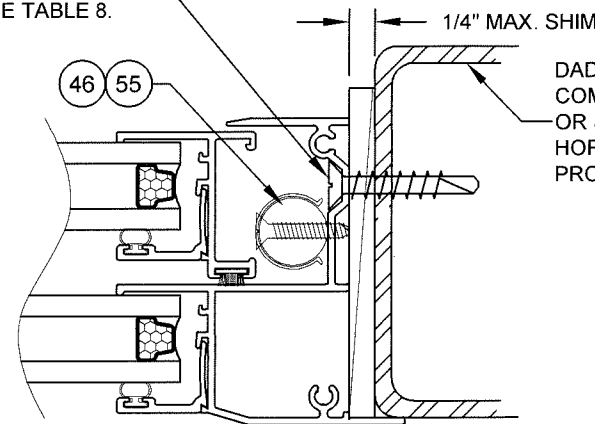

VISIBLE LIGHT FORMULAS:
 (SHOWN FOR HI-RISE SILL; SEE SHEET 10 FOR STANDARD SILL)

WIDTH
 @ SASH & FIXED LITE: TIP TO TIP WIDTH - 5.12"

HEIGHT (EQUAL-LITE)
 TIP TO TIP HEIGHT/2 - 3.73"

HEIGHT (PROVIEW)
 @FIXED LITE: TIP TO TIP HEIGHT/2 + 3.78"
 @SASH: TIP TO TIP HEIGHT/2 - 11.93"

HEIGHT (CUSTOM SASH)
 @FIXED LITE: TIP TO TIP HEIGHT - SASH HEIGHT - 3.55"
 @SASH: SASH HEIGHT - 4.60"

NOTES:

- 1) USE ONLY SUBSTRATE-APPROPRIATE ANCHORS LISTED ON TABLE 8. FOLLOW EMBEDMENT AND EDGE DISTANCE LIMITS. ANY INSTALLATION OPTION SHOWN MAY BE USED ON ANY SIDE OF THE WINDOW.
- 2) MASONRY ANCHORS MAY BE USED INTO WOOD AS PER TABLE 8. ALL WOOD BUCKS LESS THAN 1-1/2" THICK ARE TO BE CONSIDERED 1X INSTALLATIONS. 1X WOOD BUCKS ARE OPTIONAL IF UNIT IS INSTALLED DIRECTLY TO SUBSTRATE. WOOD BUCKS DEPICTED AS 2X ARE 1-1/2" THICK OR GREATER. 1X AND 2X BUCKS (WHEN USED) SHALL BE DESIGNED TO PROPERLY TRANSFER LOADS TO THE STRUCTURE. WOOD BUCK DESIGN AND INSTALLATION IS THE RESPONSIBILITY OF THE ENGINEER OR ARCHITECT OF RECORD.
- 3) VISIBLE LIGHT WIDTH OR HEIGHT (ALSO REFERRED TO AS DAYLIGHT OPENING) IS MEASURED FROM BEADING TO BEADING.

Approved as complying with the Florida Building Code
 Date: Aug. 13, 2018
 NOAH 180430.07
 Miami Dade Product Control

Manuel Berg

Revision:

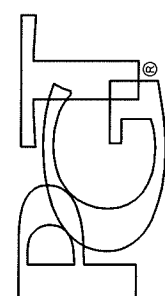
1070 TECHNOLOGY DRIVE N. VENICE, FL 34275 (941) 480-1600	COPYRIGHT © 2018 PGT INDUSTRIES, INC. ALL RIGHTS RESERVED	Date	04/01/18
		By	JENS ROSOWSKI
	CERT. OF AUTH. #29296	ALUMINUM SINGLE HUNG INSTALL. (NI)	
		FLANGE X-SECTION	
SH7600A	8 OF 12	7600NOA-1	Rev.

ANTHONY LYNN MILLER
 LICENSE
 No. 58705
 8/8/18
 STATE OF FLORIDA
 PROFESSIONAL ENGINEER
 A. LYNN MILLER, P.E.
 P.E.# 58705

INSTALLATION DETAILS FOR EQUAL-LEG FRAMES

INSTALLATION OPTION 1
 ANCHORED THROUGH FRAME INTO 2X WOOD FRAME OR BUCKSTRIP. SEE NOTE 2, THIS SHEET.

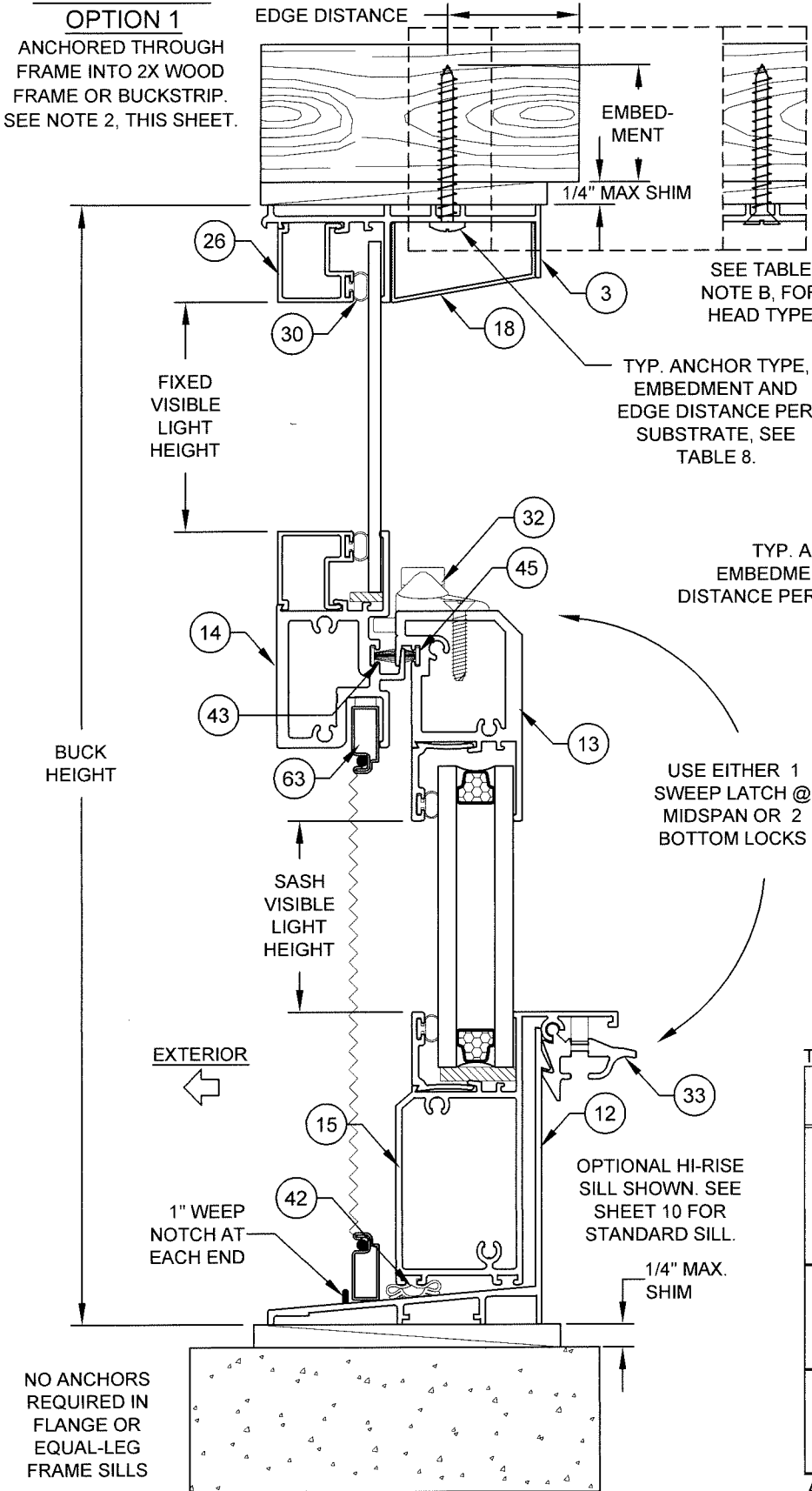

VERTICAL SECTION B-B

INSTALLATION OPTION 2
 ANCHORED THROUGH FRAME DIRECTLY INTO CONCRETE/CMU.

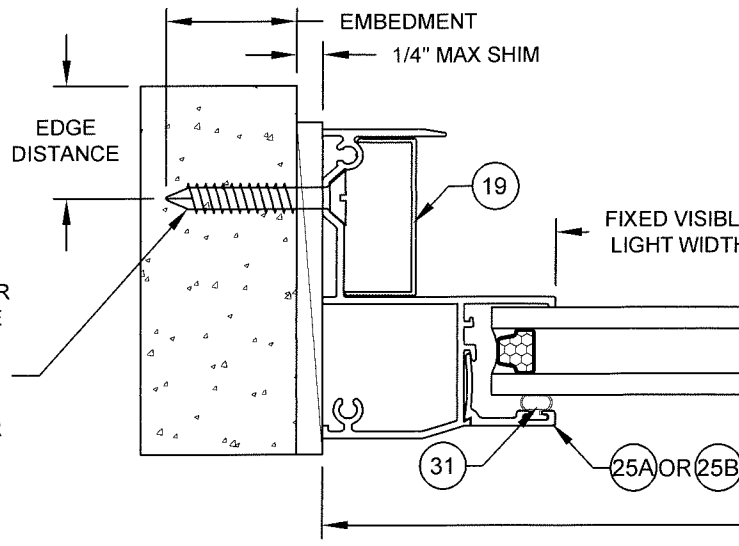

HORIZONTAL SECTION A-A

INSTALLATION OPTION 3
 ANCHORED THROUGH FRAME AND 1X BUCKSTRIP INTO CONCRETE/CMU. SEE NOTE 2, THIS SHEET.

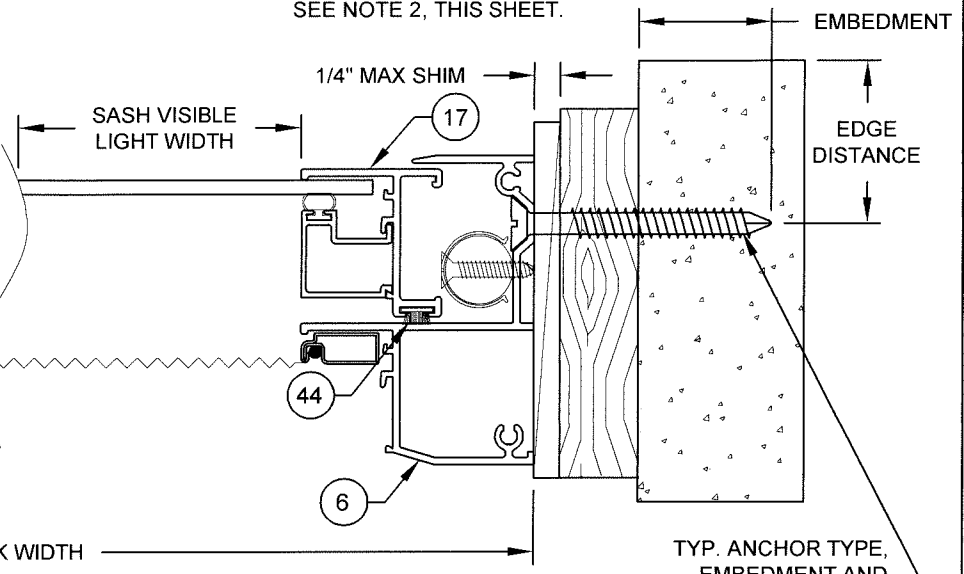

TYP. ANCHOR TYPE, EMBEDMENT AND EDGE DISTANCE PER SUBSTRATE, SEE TABLE 8.

TYP. ANCHOR TYPE, EMBEDMENT AND EDGE DISTANCE PER SUBSTRATE, SEE TABLE 8.

TYP. ANCHOR TYPE, EMBEDMENT AND EDGE DISTANCE PER SUBSTRATE, SEE TABLE 8.

USE EITHER 1 SWEEP LATCH @ MIDSPAN OR 2 BOTTOM LOCKS

DADE APPROVED MULLION, FBC COMPLIANT ALUMINUM/STEEL FRAMING OR STEEL STUD. MAY BE VERTICAL OR HORIZONTAL. SEE SUBSTRATE PROPERTIES, TABLE 8.

INSTALLATION OPTION 4
 ANCHORED THROUGH FRAME INTO METAL

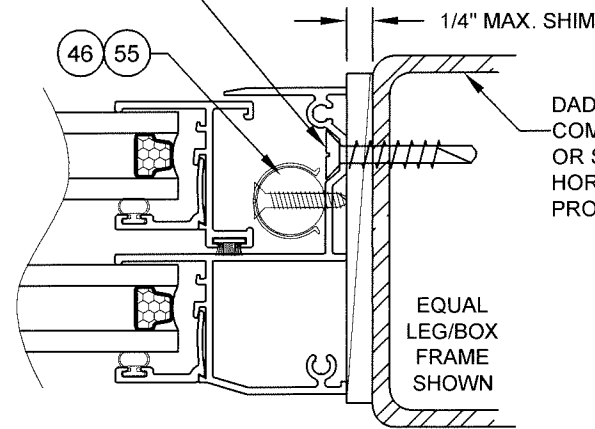

VISIBLE LIGHT FORMULAS:
 (SHOWN FOR HI-RISE SILL; SEE SHEET 10 FOR STANDARD SILL)

WIDTH
 @ SASH & FIXED LITE: BUCK WIDTH - 4.12"

HEIGHT (EQUAL-LITE)
 BUCK HEIGHT/2 - 3.23"

HEIGHT (PROVIEW)
 @FIXED LITE: BUCK HEIGHT/2 + 4.28"
 @SASH: BUCK HEIGHT/2 - 11.43"

HEIGHT (CUSTOM SASH)
 @FIXED LITE: BUCK HEIGHT - SASH HEIGHT - 2.55"
 @SASH: SASH HEIGHT - 4.60"

NOTES:

1) USE ONLY SUBSTRATE-APPROPRIATE ANCHORS LISTED ON TABLE 8. FOLLOW EMBEDMENT AND EDGE DISTANCE LIMITS. ANY INSTALLATION OPTION SHOWN MAY BE USED ON ANY SIDE OF THE WINDOW.

2) MASONRY ANCHORS MAY BE USED INTO WOOD AS PER TABLE 8. ALL WOOD BUCKS LESS THAN 1-1/2" THICK ARE TO BE CONSIDERED 1X INSTALLATIONS. 1X WOOD BUCKS ARE OPTIONAL IF UNIT IS INSTALLED DIRECTLY TO SUBSTRATE. WOOD BUCKS DEPICTED AS 2X ARE 1-1/2" THICK OR GREATER. 1X AND 2X BUCKS (WHEN USED) SHALL BE DESIGNED TO PROPERLY TRANSFER LOADS TO THE STRUCTURE. WOOD BUCK DESIGN AND INSTALLATION IS THE RESPONSIBILITY OF THE ENGINEER OR ARCHITECT OF RECORD.

3) VISIBLE LIGHT WIDTH OR HEIGHT (ALSO REFERRED TO AS DAYLIGHT OPENING) IS MEASURED FROM BEADING TO BEADING.

TABLE 8:

Anchor	Substrate	Min. Edge Distance	Min. Embedment
#12 Steel, 18-8 or 410 SS Screw	P.T. Southern Pine (SG=0.55)	9/16"	1-3/8"
	Aluminum, 6063-T5 min.	3/8"	0.063"
	A36 Steel	3/8"	0.063"
1/4" 410 SS CreteFlex	Steel Stud, Gr. 33 min.	3/8"	0.045" (18 Ga)
	Concrete (min. 3.35 ksi)	1"	1-3/4"
	UngROUTED CMU, (ASTM C-90)	2-1/2"	1-1/4"
1/4" Steel Ultracon	P.T. Southern Pine (SG=0.55)	1"	1-3/8"
	Concrete (min. 2.85 ksi)	1"	1-3/8"
	UngROUTED CMU, (ASTM C-90)	2-1/2"	1-1/4"
	P.T. Southern Pine (SG=0.55)	1"	1-3/8"

A) MIN. OF 3 THREADS BEYOND THE METAL SUBSTRATE.
 B) USE ONLY FLATHEAD ANCHORS IN JAMBS. PAN/HEX/FLAT HEAD TYPE IS ALLOWABLE FOR ANCHORS IN THE HEAD.
 C) "UNGROUTED CMU" VALUES MAY BE USED FOR GROUTED CMU APPLICATIONS.

Approved as complying with the Florida Building Code
 Date: *Apr. 23, 2018*
 NOA#: *1800430.07*
 Miami Dade Product Control
Manuel Perez

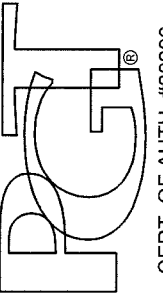
1070 TECHNOLOGY DRIVE N. VENICE, FL 34275 (941) 480-1600	COPYRIGHT © 2018 PGT INDUSTRIES, INC. ALL RIGHTS RESERVED	Date	04/01/18
		Drawn By	JENS ROSOWSKI
 CERT. OF AUTH. #29296 ALUMINUM SINGLE HUNG INSTALL. (NI) EQUAL-LEG X-SECTION	SH7600A 9 OF 12 7600NOA-1	No.	7600NOA-1
		Series	SH7600A

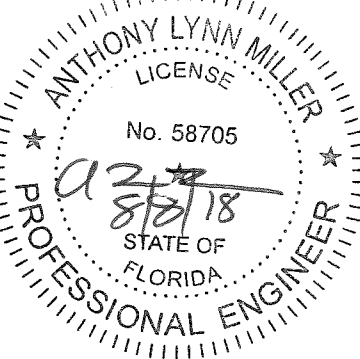
 ANTHONY LYNN MILLER
 LICENSE
 No. 58705
 STATE OF FLORIDA
 PROFESSIONAL ENGINEER
 A. LYNN MILLER, P.E.
 P.E.# 58705

INSTALLATION DETAILS FOR INTEGRAL FIN FRAMES

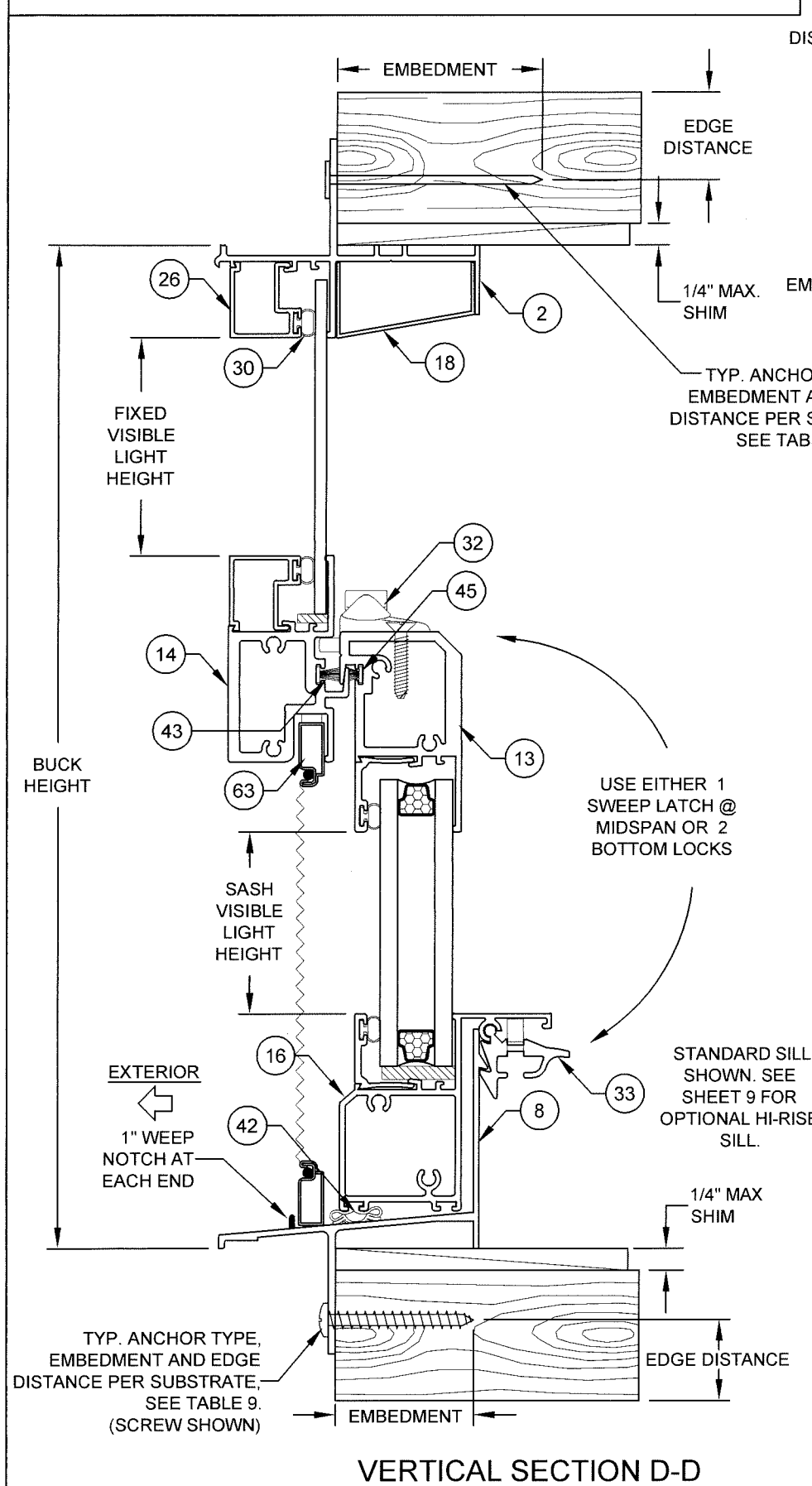

VERTICAL SECTION D-D

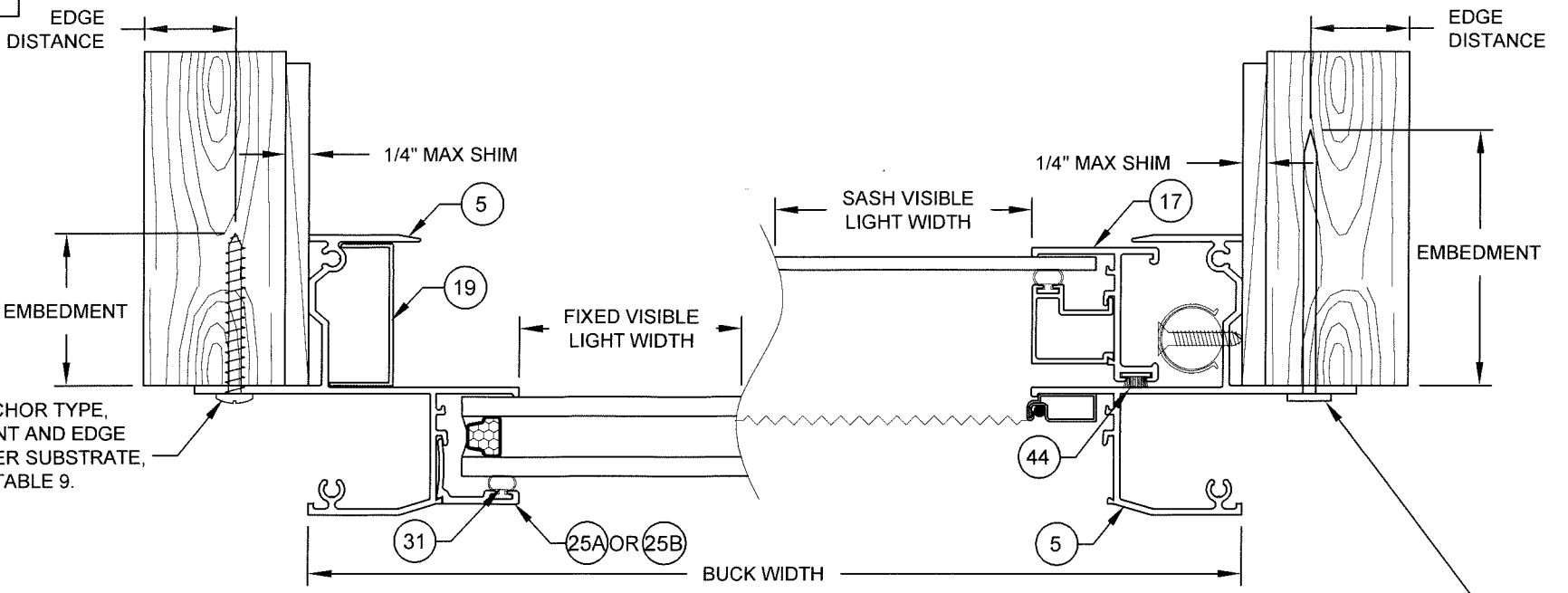

HORIZONTAL SECTION C-C

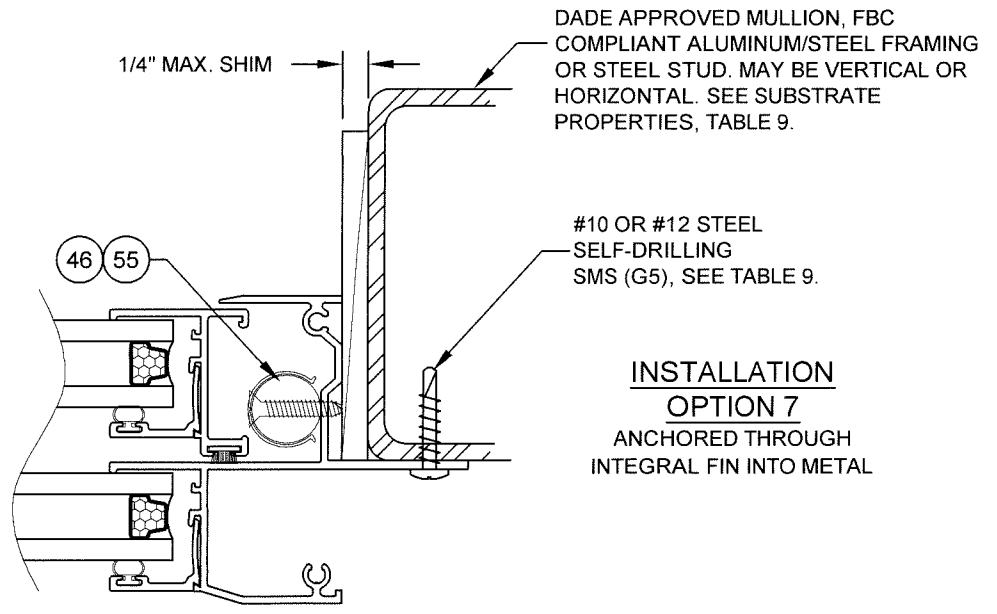

INSTALLATION OPTION 7
ANCHORED THROUGH INTEGRAL FIN INTO METAL

VISIBLE LIGHT FORMULAS:
(SHOWN FOR STANDARD SILL; SEE SHEET 8 OR 9 FOR HI-RISE SILL)

WIDTH
@ SASH & FIXED LITE: BUCK WIDTH - 4.12"

HEIGHT (EQUAL-LITE)
BUCK HEIGHT/2 - 3.23"

HEIGHT (PROVIEW)
@FIXED LITE: BUCK HEIGHT/2 + 4.28"
@SASH: BUCK HEIGHT/2 - 11.43"

HEIGHT (CUSTOM SASH)
@FIXED LITE: BUCK HEIGHT - SASH HEIGHT - 2.55"
@SASH: SASH HEIGHT - 4.60"

TABLE 9:

Anchor	Substrate	Min. Edge Distance	Min. Embedment
2-1/2" x .113" Box Nail	P.T. Southern Pine (SG=0.55)	5/16"	2.438
2-1/2" x .131" Common Nail	P.T. Southern Pine (SG=0.55)	3/8"	2.438
2-1/2" x .145" Roofing Nail	P.T. Southern Pine (SG=0.55)	3/8"	2.438
2-1/2" x .145" Roofing Nail	P.T. Southern Pine (SG=0.55)	3/8"	2.438
#10 Steel Trusshead Screw or #12 Steel, 18-8 or 410 SS Screw	P.T. Southern Pine (SG=0.55)	1/2"	1.375
	0.125" Aluminum, 6063-T5 min.	5/16"	0.090
	0.050" A36 Steel	5/16"	0.050
	0.045" (18 Ga) Steel Stud, Gr. 33 min.	5/16"	0.0450

A) MIN. OF 3 THREADS BEYOND THE METAL SUBSTRATE.

- NOTES:**
- 1) USE ONLY SUBSTRATE-APPROPRIATE ANCHORS LISTED ON TABLE 8. FOLLOW EMBEDMENT AND EDGE DISTANCE LIMITS. ANY INSTALLATION OPTION SHOWN MAY BE USED ON ANY SIDE OF THE WINDOW.
 - 2) VISIBLE LIGHT WIDTH OR HEIGHT (ALSO REFERRED TO AS DAYLIGHT OPENING) IS MEASURED FROM BEADING TO BEADING.

Approved as complying with the Florida Building Code
Date: Aug. 23, 2018
NOA# 18-30430-07
Miami Dade Product Control
Manuel Perez

1070 TECHNOLOGY DRIVE
N. VENICE, FL 34275
(941) 480-1600

COPYRIGHT © 2018 PGT INDUSTRIES, INC.
ALL RIGHTS RESERVED

DATE: 04/01/18
BY: JENS ROSOWSKI
DRAWN BY: JENS ROSOWSKI
NO. 7600NOA-1

PGI
CERT. OF AUTH. #29296

ALUMINUM SINGLE HUNG INSTALL. (NI)
INTEGRAL FIN X-SECTION
SH7600A
10 OF 12
Sheet

ANTHONY LYNN MILLER
LICENSE
No. 58705
AUG 23 2018
STATE OF FLORIDA
PROFESSIONAL ENGINEER

A. LYNN MILLER, P.E.
P.E. # 58705

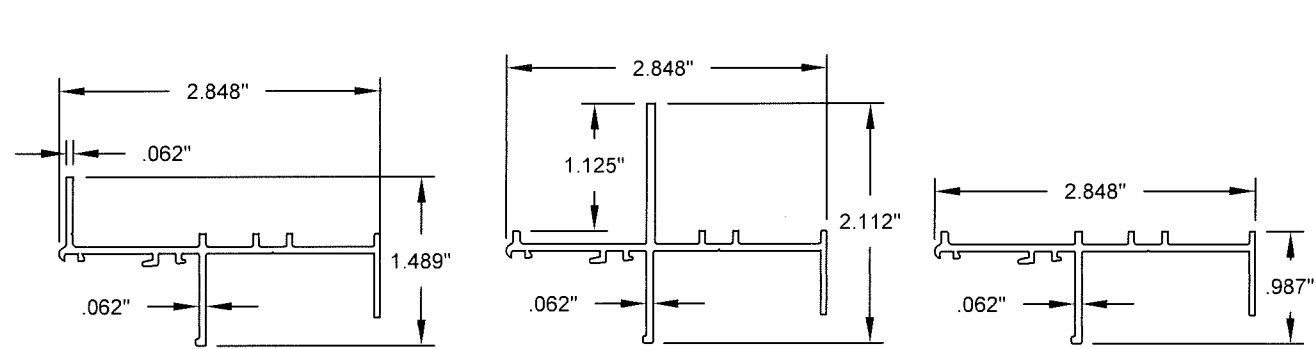

① FLANGE FRAME HEAD ② INTEGRAL FIN FRAME HEAD ③ EQUAL LEG FRAME HEAD

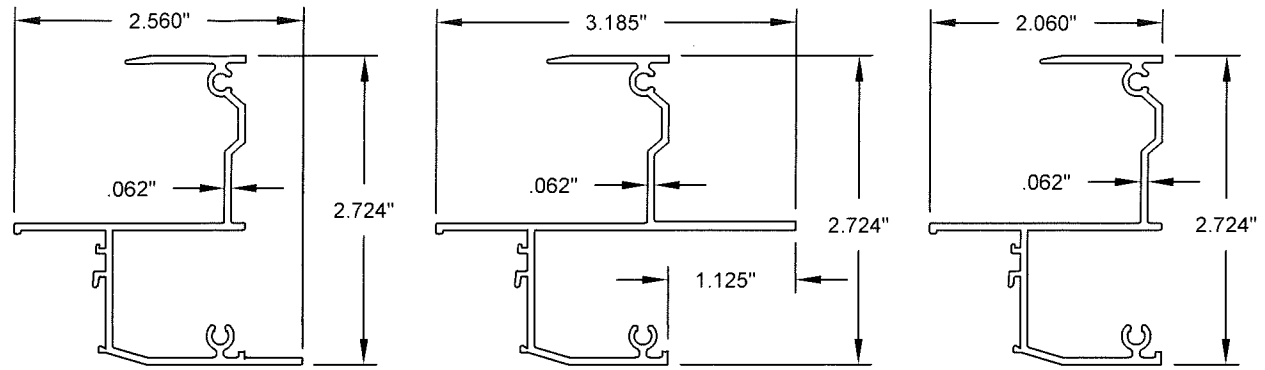

④ FLANGE FRAME JAMB ⑤ INTEGRAL FIN FRAME JAMB ⑥ EQUAL LEG FRAME JAMB

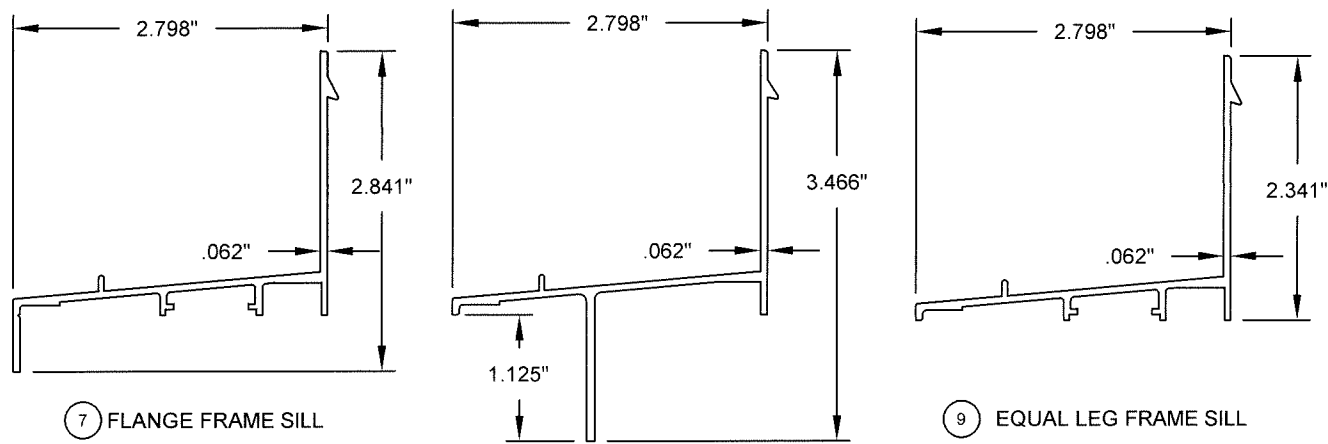

⑦ FLANGE FRAME SILL ⑧ INTEGRAL FIN FRAME SILL ⑨ EQUAL LEG FRAME SILL

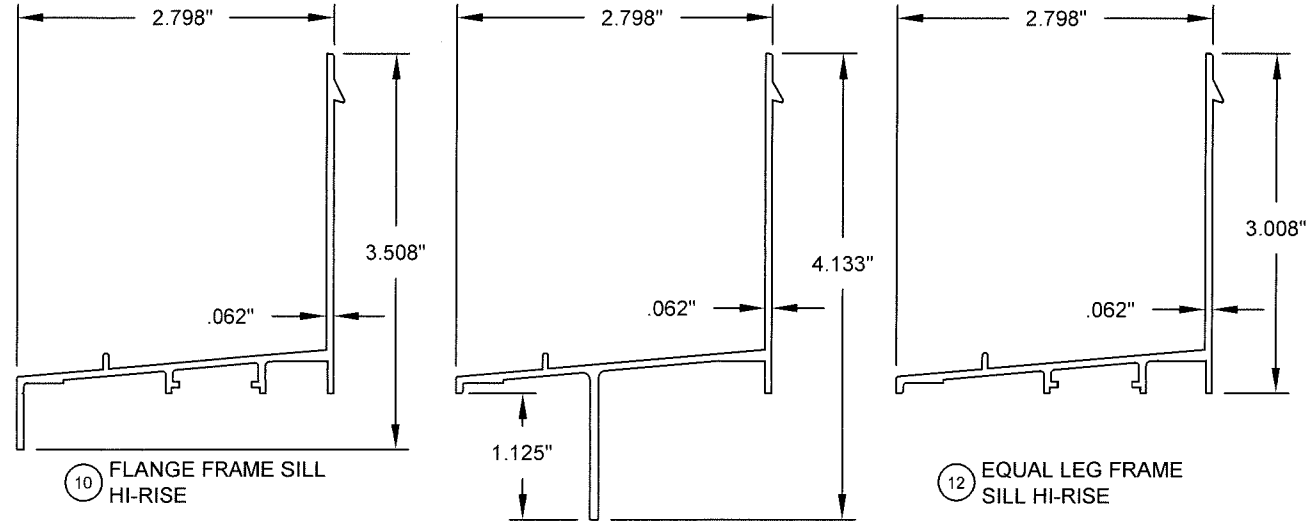

⑩ FLANGE FRAME SILL HI-RISE ⑪ INTEGRAL FIN FRAME SILL - HI-RISE ⑫ EQUAL LEG FRAME SILL HI-RISE

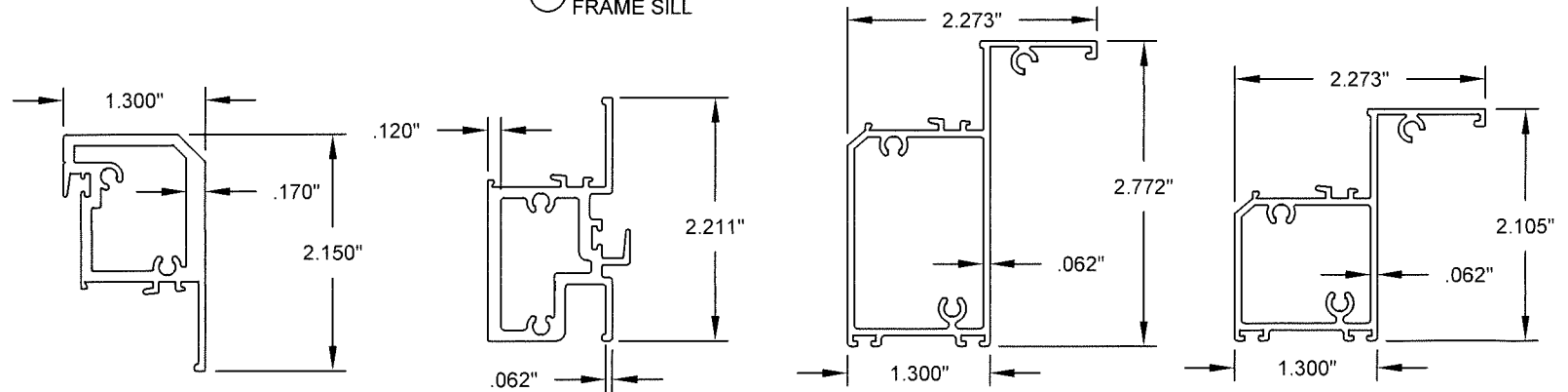

⑬ SASH TOP RAIL ⑭ FIXED MEETING RAIL ⑮ SASH BOTTOM RAIL - HI-RISE ⑯ SASH BOTTOM RAIL

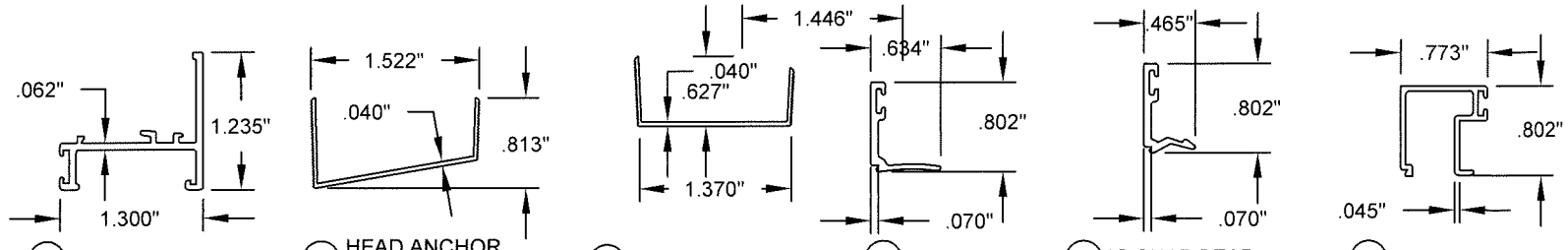

⑰ SASH SIDE RAIL ⑱ HEAD ANCHOR COVER ⑲ SASH STOP COVER 25A IG BEAD 25B IG SNAP BEAD 26 1/8" & 3/16" BEAD

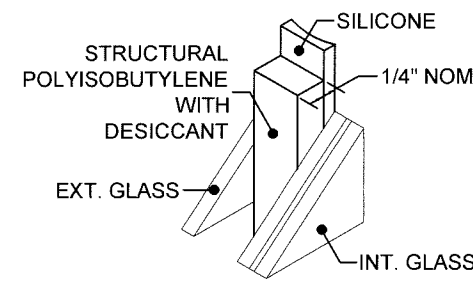

⑦⑦ KODISPACE 4SG TPS

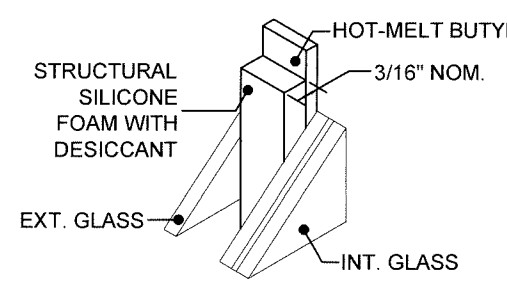

⑦⑧ SUPER SPACER[®] NXT[™]

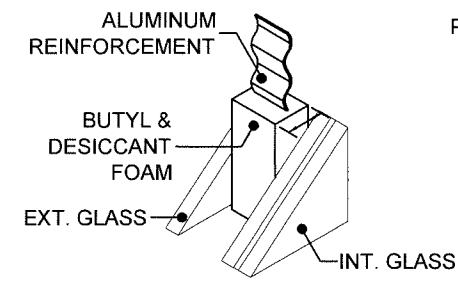

⑦⑨ DURASEAL[®] SPACER

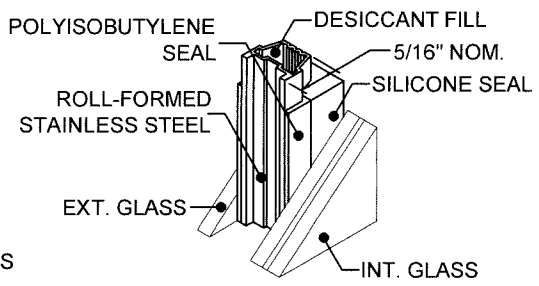

⑦⑩ XL EDGE[™] SPACER

Approved as complying with the Florida Building Code
 Date: Aug 23 2018
 NCAN: 18 20450.07
 Minimal Date Product Control
Manual Proj

Revision:

1070 TECHNOLOGY DRIVE
 N. VENICE, FL 34275
 (941) 480-1600
 COPYRIGHT © 2018 PGT INDUSTRIES, INC.
 ALL RIGHTS RESERVED
 1070 TECHNOLOGY DRIVE
 N. VENICE, FL 34275
 (941) 480-1600

11 OF 12
 SHEET
 SH7600A
 EXTRUSIONS
 ALUMINUM SINGLE HUNG INSTALL. (NI)
 JENS ROSOWSKI
 7600NOA-1

ANTHONY LYNN MILLER
 LICENSE
 No. 58705
 8/9/18
 STATE OF FLORIDA
 PROFESSIONAL ENGINEER
 A. LYNN MILLER, P.E.
 P.E.# 58705

TABLE 11:

Item #	PGT Part #	Description	Material
1	642001	Head, Flange	Alum. 6063-T6
2	642017	Head, Integral Fin	Alum. 6063-T6
3	624028	Head, Equal-leg	Alum. 6063-T6
4	624004	Jamb, Flange	Alum. 6063-T6
4A		Jamb, Flange (Used For Alternate Radius Top Head)	Alum. 6063-T52
5	624020	Jamb, Integral Fin	Alum. 6063-T6
5A		Jamb, Integral Fin (Used For Alternate Radius Top Head)	Alum. 6063-T52
6	624031	Jamb, Equal-leg	Alum. 6063-T6
6A		Jamb, Equal-leg (Used For Alternate Radius Top Head)	Alum. 6063-T52
7	624002	Sill, Flange	Alum. 6063-T6
8	624018	Sill, Integral Fin	Alum. 6063-T6
9	624029	Sill, Equal-leg	Alum. 6063-T6
10	624003	Sill, Hi-Rise, Flange	Alum. 6063-T6
11	624019	Sill, Hi-Rise, Integral Fin	Alum. 6063-T6
12	624030	Sill, Hi-Rise, Equal-leg	Alum. 6063-T6
13	624006	Sash Top Rail	Alum. 6005A-T61
14	624005	Fixed Meeting Rail	Alum. 6005A-T61
15	624012	Sash Bottom Rail - Hi-Rise	Alum. 6063-T6
16	624068	Sash Bottom Rail	Alum. 6063-T6
17	624007	Sash Side Rail	Alum. 6063-T6
18	624051	Head Anchor Cover	Alum. 6063-T6
19	624015	Sash Stop	Alum. 6063-T6
25A	624009	IG Bead	Alum. 6063-T5
25B	624011	IG Snap Bead	Alum. 6063-T5
26	624013	1/8" & 3/16" Bead	Alum. 6063-T6
30	6TP247	Glazing Bead, Bulb Vinyl for #624023	Vinyl
31	6TP248	Glazing Bead, Bulb Vinyl for #624009 & #624011	Vinyl
32	724046	Sweep Latch (@ Top Rail)	Cast Zinc
33	624049	Bottom Latch (@ Sill)	Alum. 6063-T6
34		Setting Block (1/8" X 1/2" X 4")	Neoprene
35A		IG Setting Block (1/8" X 3/4" X 4")	Neoprene
35B	724014	IG Snap Setting Block	Vinyl
36	724044	Bottom Rail Weatherstrip Extension	
37	724053	Sill Gasket	Polyethylene
38	724054	Sash Top Rail Gasket	Polyethylene
39	724055	Sash Bottom Rail Gasket	Polyethylene
40	724057	Head Gasket	Polyethylene
41	724063	Meeting Rail Gasket	Polyethylene
42	61226D	Sash Bottom Rail Bulb Vinyl	Polyethylene
43		Weatherstrip, .270" X .187", Fin Seal (@ MR)	
44	67S16G	Weatherstrip, .170" X .270", Fin Seal (@ Sash Side Rail)	
45		Weatherstrip, .170" X .187", Fin Seal (@ Top Sash Rail)	
46	varies	Balance with Cover & Trim	Rigid Vinyl
51	781PSQX	#8 X 1" PH SMS (Assembly)	Stainless Steel
55	7834AA	#8 X 3/4" Ph. PN SMS (Balance)	Stainless Steel
63	-	Alum. Screen with Fiberglass Mesh	Varies
70	-	Kommerling Kodispace 4SG TPS	See Sheet 11 for Materials
71	-	Quanex Super Spacer nXT	
72	-	Quanex Duraseal Spacer	
73	-	Cardinal XL Edge Spacer	
74	-	Dow 791, 899 or GE 7700 Backbedding	Silicone

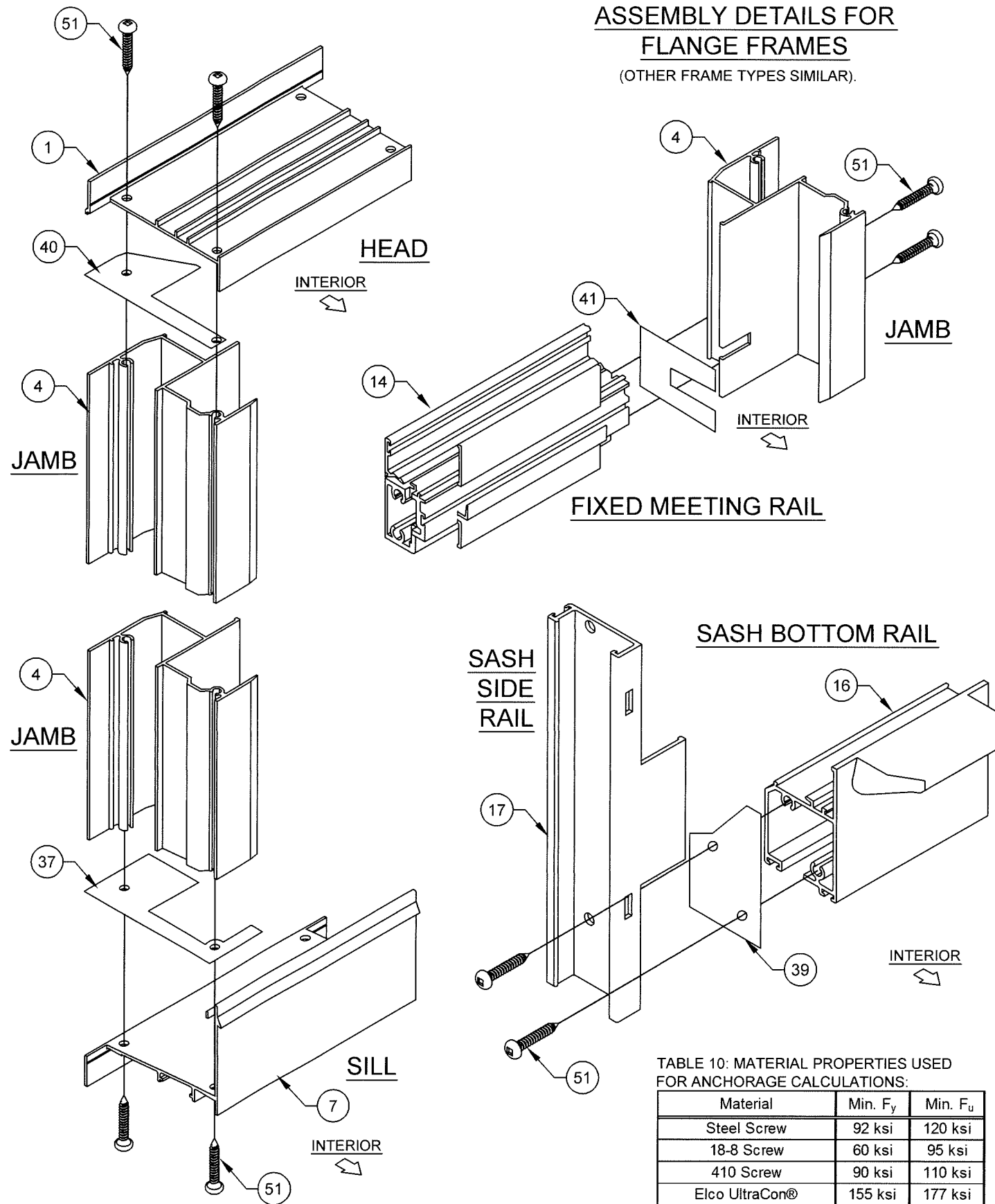

NOTES:

- 1) ALL CORNERS TO USE GASKET AND/OR SEALANT.
- 2) SOME PARTS/OPTIONS NOT SHOWN ON DRAWING FOR CLARITY.

TABLE 10: MATERIAL PROPERTIES USED FOR ANCHORAGE CALCULATIONS:

Material	Min. F _y	Min. F _u
Steel Screw	92 ksi	120 ksi
18-8 Screw	60 ksi	95 ksi
410 Screw	90 ksi	110 ksi
Elco UltraCon®	155 ksi	177 ksi
410 SS Elco CreteFlex®	127.4 ksi	189.7 ksi
6063-T5 Aluminum	16 ksi	22 ksi
A36 Steel	36 ksi	58 ksi
Gr. 33 Steel Stud	33 ksi	45 ksi

Approved as complying with the Florida Building Code
 Date: Aug. 23, 2018
 No. 18-00430-07
 Miami Dade Product Control

Manuel Perez

1070 TECHNOLOGY DRIVE
 N. VENICE, FL 34275
 (941) 480-1600

COPYRIGHT © 2018 PGT INDUSTRIES, INC.
 ALL RIGHTS RESERVED

12 OF 12

PGT®
 CERT. OF AUTH. #29296

ALUMINUM SINGLE HUNG INSTALL. (NI)
 BOM & CORNER DETAILS

JENS ROSOWSKI
 SH7600A
 7600NOA-1

ANTHONY LYNN MILLER
 LICENSE
 No. 58705
 STATE OF FLORIDA
 PROFESSIONAL ENGINEER

A. LYNN MILLER, P.E.
 P.E.# 58705