



DEPARTMENT OF REGULATORY AND ECONOMIC RESOURCES (RER)  
BOARD AND CODE ADMINISTRATION DIVISION

**NOTICE OF ACCEPTANCE (NOA)**

MIAMI-DADE COUNTY  
PRODUCT CONTROL SECTION  
11805 SW 26 Street, Room 208  
Miami, Florida 33175-2474  
T (786) 315-2590 F (786) 315-2599  
[www.miamidade.gov/economy](http://www.miamidade.gov/economy)

**ECO Windows Systems, LLC**  
9114 N. W. 106<sup>th</sup> Street,  
Medley, FL 33178

**SCOPE:**

This NOA is being issued under the applicable rules and regulations governing the use of construction materials. The documentation submitted has been reviewed and accepted by Miami-Dade County RER -Product Control Section to be used in Miami Dade County and other areas where allowed by the Authority Having Jurisdiction (AHJ).

This NOA shall not be valid after the expiration date stated below. The Miami-Dade County Product Control Section (In Miami Dade County) and/or the AHJ (in areas other than Miami Dade County) reserve the right to have this product or material tested for quality assurance purposes. If this product or material fails to perform in the accepted manner, the manufacturer will incur the expense of such testing and the AHJ may immediately revoke, modify, or suspend the use of such product or material within their jurisdiction. RER reserves the right to revoke this acceptance, if it is determined by Miami-Dade County Product Control Section that this product or material fails to meet the requirements of the applicable building code.

This product is approved as described herein, and has been designed to comply with the Florida Building Code, including the High Velocity Hurricane Zone.

**DESCRIPTION: Series "700" Aluminum Sliding Glass Door w/ Reinforcements-L.M.I.**

**APPROVAL DOCUMENT:** Drawing No. **W13-49 REV D**, titled "Series- 700 Alum SLD. Glass Door (L.M.I.)", sheets 1 through 12 of 12, prepared by Al-Farooq Corporation, dated 09/27/13 and last revised on JAN 23, 2018, signed and sealed by Javad Ahmad, P.E., bearing the Miami-Dade County Product Control Renewal stamp with the Notice of Acceptance number and expiration date by the Miami-Dade County Product Control Section.

**MISSILE IMPACT RATING: Large and Small Missile Impact Resistant**

**Limitations:**

1. See Design Pressures Vs Reinforcing, glass types and anchor capacity charts in sheet **5**. Exterior (positive) design pressures are limited to **+70 PSF w / 2-3/4"** sill riser and **+47.0 PSF w/ 2"** sill riser. Lower design Pressure from charts applies to entire system.
2. See approved configurations in sheets 1 thru 4. The max frame are of alternate sizes not to exceed tested frame area per FBC requirements.

**LABELING:** Each unit shall bear a permanent label with the manufacturer's name or logo, city, state and series and following statement: "Miami-Dade County Product Control Approved", noted herein.

**RENEWAL** of this NOA shall be considered after a renewal application has been filed and there has been no change in the applicable building code negatively affecting the performance of this product.

**TERMINATION** of this NOA will occur after the expiration date or if there has been a revision or change in the materials, use, and/or manufacture of the product or process. Misuse of this NOA as an endorsement of any product, for sales, advertising or any other purposes shall automatically terminate this NOA. Failure to comply with any section of this NOA shall be cause for termination and removal of NOA.

**ADVERTISEMENT:** The NOA number preceded by the words Miami-Dade County, Florida, and followed by the expiration date may be displayed in advertising literature. If any portion of the NOA is displayed, then it shall be done in its entirety.

**INSPECTION:** A copy of this entire NOA shall be provided to the user by the manufacturer or its distributors and shall be available for inspection at the job site at the request of the Building Official.

This NOA **renews #18-0129.13** consists of this page 1 and evidence pages E-1 and E-2, as well as approval document mentioned above.

The submitted documentation was reviewed by **Ishaq I. Chanda, P.E.**



4  
1/10/19

NOA No. 18-1220.09  
Expiration Date: March 20, 2024  
Approval Date: January 17, 2019  
Page 1

**NOTICE OF ACCEPTANCE: EVIDENCE SUBMITTED**

**1. Evidence submitted under previous approvals**

**A. DRAWINGS**

1. Manufacturer's die drawings and sections (see below)
2. Drawing No. **W13-49 REV C**, titled "Series- 700 Alum SLD. Glass Door (L.M.I.)", sheets 1 through 12 of 12, prepared by Al-Farooq Corporation, dated 09/27/13 and last revised on DEC 02, 2015, signed and sealed by Javad Ahmad, P.E.

**B. TESTS** (Submitted under file #13-0912.02)

1. Test reports on:
  - 1) Air Infiltration Test, per FBC, TAS 202-94
  - 2) Uniform Static Air Pressure Test, Loading per FBC TAS 202-94
  - 3) Water Resistance Test, per FBC, TAS 202-94
  - 4) Large Missile Impact Test per FBC, TAS 201-94
  - 5) Cyclic Wind Pressure Loading per FBC, TAS 203-94
  - 6) Forced Entry Test, per FBC 2411 3.2.1, TAS 202-94

along with marked-up drawings and installation diagrams of Alum sliding Glass doors, prepared by Fenestration Testing Lab, Inc., Test Report No. **FTL-7405** dated 09/13/2013 and last revised on 02/10/2014, signed and sealed by Marlin D. Brinson, P. E.

Note: The above referenced test report has an addendum letter dated FEB 10, 2014, issued by Fenestration Testing Lab, Inc., signed by Ms. Iliana Sanchez, test report Author.

**C. CALCULATIONS**

1. Anchor verification calculations and structural analysis, complying with FBC-2014 (5<sup>th</sup> Edition), prepared by Al Farooq Corporation, dated 06/10/15 and last revised on DEC 02, 2015, signed and sealed by Javad Ahmad, P.E.
2. Glazing complies w/ ASTM E-1300-02, -04 & -09.

**D. QUALITY ASSURANCE**

1. Miami Dade Department of Regulatory and Economic Resources (RER).

**E. MATERIAL CERTIFICATIONS**

1. Notice of Acceptance No. **14-0916.10** issued to **Kuraray America, Inc.** (Former E.I. DuPont DeNemours & Co., Inc.) for the "**Kuraray Butacite ® PVB interlayer**", expiring on 12/11/16.
2. Notice of Acceptance No. **14-0916.11** issued to **Kuraray America, Inc.** (Former E.I. DuPont DeNemours & Co., Inc.) for the "**Sentry Glass ® (Clear and White) Glass Interlayers**", expiring on 07/04/17.

**F. STATEMENTS**

1. Statement letter of conformance to FBC 2014(5<sup>th</sup> Edition) and letter of no financial interest, prepared by Al Farooq Corporation, dated 06/10/15, signed and sealed by Javad Ahmad, P.E.
2. Lab compliance as part of the above referenced test report.

**G. OTHER**

1. Test proposal, dated 03/25/13 approved by Jaime D. Gascon, P.E.

**2. Evidence submitted under previous approvals**

**A. DRAWINGS**

1. Drawing No. **W13-49 REV D**, titled "Series- 700 Alum SLD. Glass Door (L.M.I.)", sheets 1 through 12 of 12, prepared by Al-Farooq Corporation, dated 09/27/13 and last revised on JAN 23, 2018, signed and sealed by Javad Ahmad, P.E.



Ishaq I. Chanda, P.E.

Product Control Unit Supervisor

NOA No. 18-1220.09

Expiration Date: March 20, 2024

Approval Date: January 17, 2019

NOTICE OF ACCEPTANCE: EVIDENCE SUBMITTED

- B. TESTS**  
1. None.
- C. CALCULATIONS**  
1. None.
- D. QUALITY ASSURANCE**  
1. Miami Dade Department of Regulatory and Economic Resources (RER).
- E. MATERIAL CERTIFICATIONS**  
1. Notice of Acceptance No. **16-1117.01** issued to Kuraray America, Inc. (former E.I. DuPont DeNemours & Co., Inc.) for “**Trosifol**: Ultra clear, clear & color PVB glass interlayer” (former “Kuraray **Butacite** PVB Interlayer”), expiring on 07/08/19.  
2. Notice of Acceptance No. **17-0808.02** issued to Kuraray America, Inc. (former E.I. DuPont DeNemours & Co., Inc.) for the “Kuraray **Sentry Glass ® Interlayer**”, expiring on 07/4/23.
- F. STATEMENTS**  
1. Statement letter of conformance to FBC 2017(6<sup>th</sup> edition) prepared by Al-Farooq Corporation, dated JAN 23, 2018, signed and sealed by Javad Ahmad, P.E.
- G. OTHER**  
1. This NOA **revises** NOA # **15-0612.05**, expiring 03/20/2019.
- 1. New Evidence submitted.**
- A. DRAWINGS**  
1. Drawing No. **W13-49 REV D**, titled “Series- 700 Alum SLD. Glass Door (L.M.I.)”, sheets 1 through 12 of 12, prepared by Al-Farooq Corporation, dated 09/27/13 and last revised on JAN 23, 2018, signed and sealed by Javad Ahmad, P.E.
- B. TESTS**  
1. None.
- C. CALCULATIONS**  
1. None.
- D. QUALITY ASSURANCE**  
1. Miami Dade Department of Regulatory and Economic Resources (RER).
- E. MATERIAL CERTIFICATIONS**  
1. Notice of Acceptance No. **16-1117.01** issued to Kuraray America, Inc. (former E.I. DuPont DeNemours & Co., Inc.) for “**Trosifol**: Ultra clear, clear & color PVB glass interlayer” (former “Kuraray **Butacite** PVB Interlayer”), expiring on 07/08/19.  
2. Notice of Acceptance No. **17-0808.02** issued to Kuraray America, Inc. (former E.I. DuPont DeNemours & Co., Inc.) for the “Kuraray **Sentry Glass ® Interlayer**”, expiring on 07/4/23.
- F. STATEMENTS (submitted under file #18-0129.13)**  
1. Statement letter of conformance to FBC 2017(6<sup>th</sup> edition) prepared by Al-Farooq Corporation, dated JAN 23, 2018, signed and sealed by Javad Ahmad, P.E.
- G. OTHER**  
1. This NOA **renews** NOA # **18-0129.13**, expiring 03/20/2024.

  
\_\_\_\_\_  
Ishaq I. Chanda, P.E.  
Product Control Unit Supervisor  
NOA No. 18-1220.09  
Expiration Date: March 20, 2024  
Approval Date: January 17, 2019

**INSTRUCTIONS:**

USE CHARTS AS FOLLOWS.

- STEP 1** SEE CHART #1 ON SHEET 5 FOR GLASS CAPACITY AND REINFORCING REQUIREMENTS.
- STEP 2** SELECT SILL TYPE FROM SHEET 7 AND LIMIT EXT.(+) DESIGN PRESSURE AS SHOWN ON DETAIL.
- STEP 3** SEE CHART #2 ON SHEET 5 FOR ANCHOR CAPACITY.
- STEP 4** THE LOWEST VALUE RESULTING FROM STEPS 1 THRU 3 SHALL APPLY TO ENTIRE SYSTEM.

**DAYLITE OPENINGS WIDTHS:**

FIXED STILE-INTERLOCK = PANEL WIDTH - 7.125"  
 INTERLOCK-ASTRAGAL = PANEL WIDTH - 7.250"

**DAYLITE OPENING HEIGHT:**

PANEL HEIGHT - 6.50"

PANEL HEIGHT = DOOR FRAME HEIGHT - 1.5625"

THESE DOORS ARE RATED FOR LARGE & SMALL MISSILE IMPACT. SHUTTERS ARE NOT REQUIRED.

**SERIES-700**

**ALUMINUM SLIDING GLASS DOOR**

THIS PRODUCT HAS BEEN DESIGNED AND TESTED TO COMPLY WITH THE REQUIREMENTS OF THE 2017 (6TH EDITION) FLORIDA BUILDING CODE INCLUDING HIGH VELOCITY HURRICANE ZONE (HVHZ).

1BY OR 2BY WOOD BUCKS & BUCK FASTENERS BY OTHERS, MUST BE DESIGNED AND INSTALLED ADEQUATELY TO TRANSFER APPLIED PRODUCT LOADS TO THE BUILDING STRUCTURE.

ANCHORS SHALL BE CORROSION RESISTANT, SPACED AS SHOWN ON DETAILS AND INSTALLED PER MANUF'S INSTRUCTIONS. SPECIFIED EMBEDMENT TO BASE MATERIAL SHALL BE BEYOND WALL DRESSING OR STUCCO.

A LOAD DURATION INCREASE IS USED IN DESIGN OF ANCHORS INTO WOOD ONLY.

ALL SHIMS TO BE HIGH IMPACT, NON-METALLIC AND NON-COMPRESSIBLE.

MATERIALS INCLUDING BUT NOT LIMITED TO STEEL/METAL SCREWS, THAT COME INTO CONTACT WITH OTHER DISSIMILAR MATERIALS SHALL MEET THE REQUIREMENTS OF THE 2017 FLORIDA BLDG. CODE & ADOPTED STANDARDS.

THIS PRODUCT APPROVAL IS GENERIC AND DOES NOT PROVIDE INFORMATION FOR A SITE SPECIFIC PROJECT, i.e. LIFE SAFETY OF THIS PRODUCT, ADEQUACY OF STRUCTURE RECEIVING THIS PRODUCT AND SEALING AROUND OPENING FOR WATER INFILTRATION RESISTANCE ETC. CONDITIONS NOT SHOWN IN THIS DRAWING ARE TO BE ANALYZED SEPARATELY, AND TO BE REVIEWED BY BUILDING OFFICIAL.

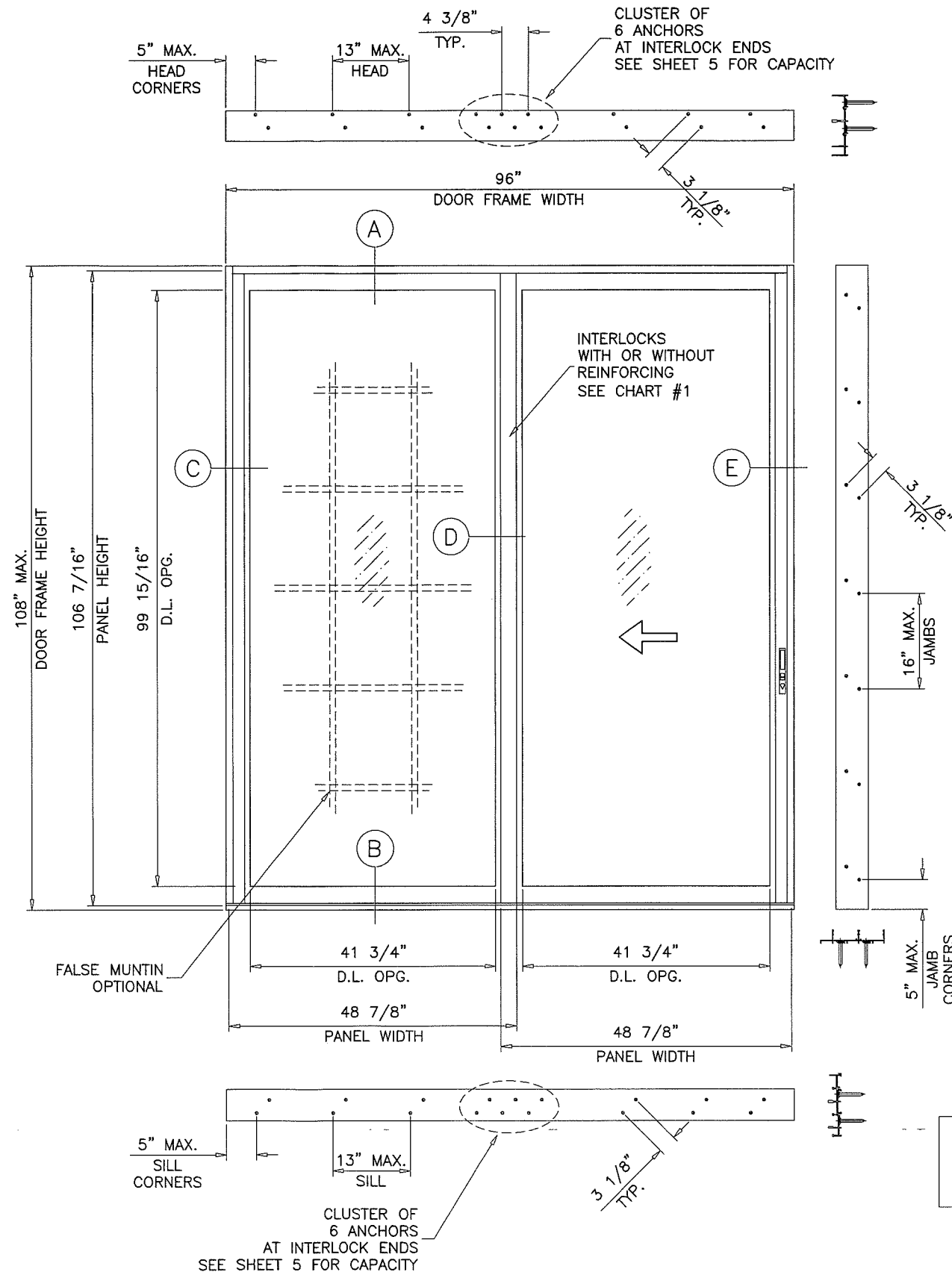

**TYPICAL ELEVATION**

OX

ALTERNATE SIZE UNITS:  
 MAX. FRAME AREA OF DOORS NOT TO EXCEED THE TESTED FRAME AREA OF 72 SQ. FT.

PRODUCT REVISED  
 as complying with the Florida Building Code  
 Acceptance No 18-1220-09  
 Expiration Date MAR 20, 2024  
 by Ishay I. Chandra  
 National Deck Product Control

PRODUCT REVISED  
 as complying with the Florida Building Code  
 Acceptance No 18-0129-13  
 Expiration Date MAR 20, 2019  
 by Ishay I. Chandra  
 National Deck Product Control

LAMINATED GLASS  
 INSUL. LAM. GLASS  
 LARGE MISSILE IMPACT

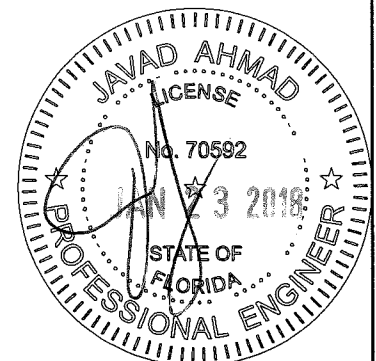

**af c**  
**AL-FAROOQ CORPORATION**  
 ENGINEERS & PRODUCT DEVELOPMENT  
 9360 SUNSET DRIVE, SUITE 220  
 MIAMI, FLORIDA 33173 (C.A.N. 3638)  
 TEL. (305) 264-8100 FAX. (305) 262-6978  
 COMP-ANL\W13-49ECCO

SERIES-700 ALUM. SLIDING GLASS DOOR (L.M.I.)  
**ECO WINDOW SYSTEMS, LLC.**  
 8502 N.W. 80th STREET  
 MEDLEY, FL. 33166  
 TEL. (305) 885-5299 FAX (305) 885-5902

NO	DATE	DESCRIPTION
A	01.16.14	REV. PER PER COMMENTS
B	06.08.15	UPDATED TO 2014 FBC
C	12.01.15	REV. PER PER COMMENTS
D	01.11.18	UPDATED TO 2017 FBC

date: 09-27-13  
 scale: 1/2"=1'-0"  
 dr. by: TARIQ  
 chk. by:

drawing no.  
**W13-49**  
 sheet 1 of 12

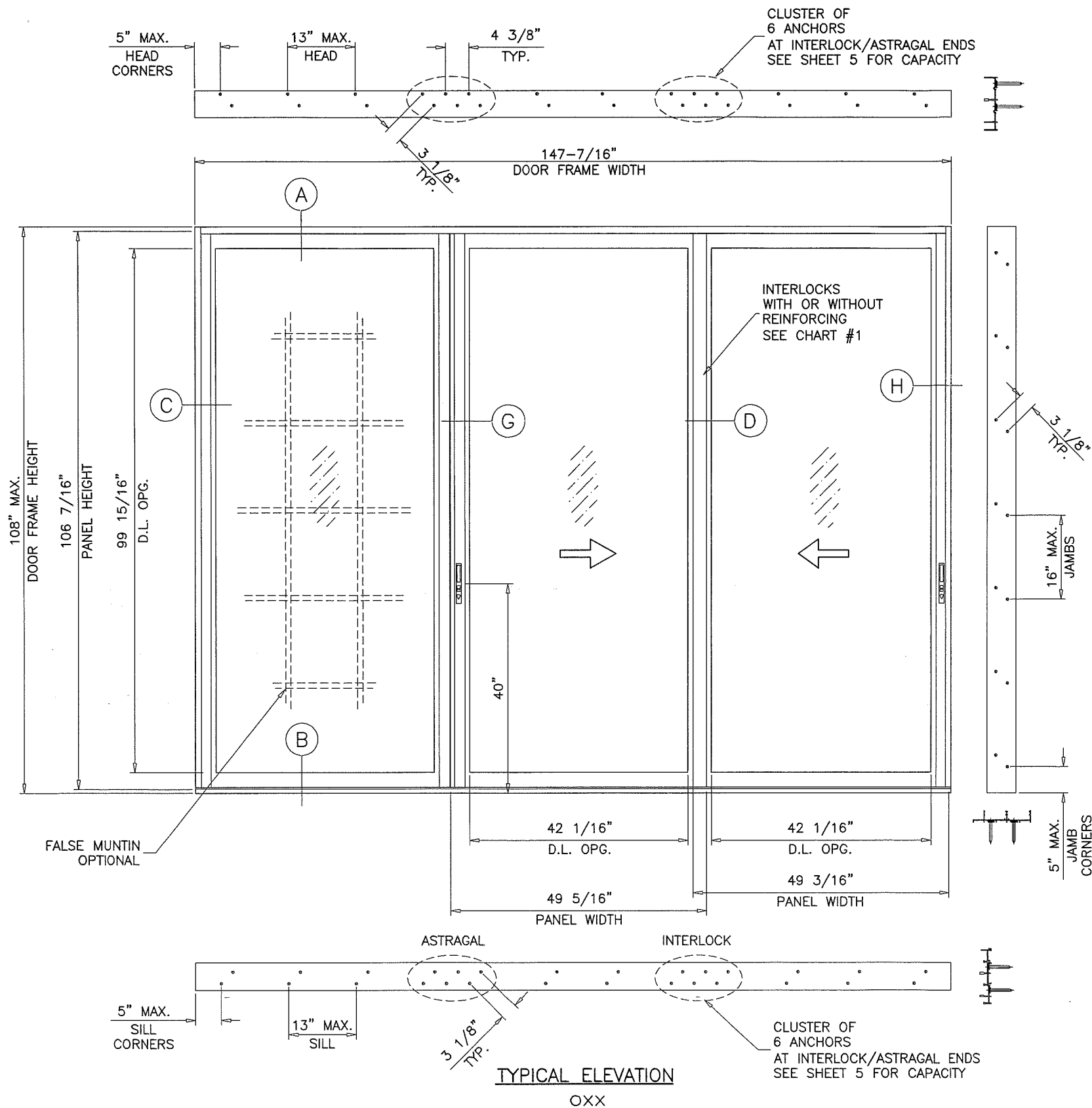

ALTERNATE SIZE UNITS:  
 MAX. FRAME AREA OF DOORS NOT TO EXCEED  
 THE TESTED FRAME AREA OF 110.7 SQ. FT.

PRODUCT RENEWED  
 as complying with the Florida  
 Building Code  
 Acceptance No 18-1220.69  
 Expiration Date 3/20/24  
 By Ishag I. Chande  
 Miami Based Product Control

PRODUCT REVISED  
 as complying with the Florida  
 Building Code  
 Acceptance No 18-0129.13  
 Expiration Date 3/20/19  
 By Ishag I. Chande  
 Miami Based Product Control

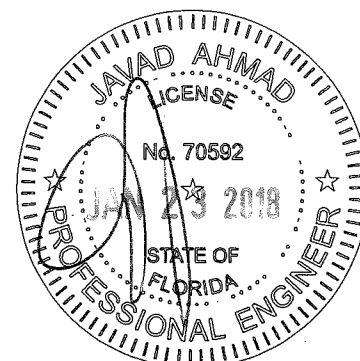

**af c**  
**AL-FAROOQ CORPORATION**  
 ENGINEERS & PRODUCT DEVELOPMENT  
 9360 SUNSET DRIVE, SUITE 220 (C.A.N. 9538)  
 MIAMI, FLORIDA 33173  
 TEL. (305) 264-8100 FAX. (305) 262-6978  
 COMP-ANL W13-49ECO

SERIES-700 ALUM SLIDING GLASS DOOR (L.M.I.)  
**ECO WINDOW SYSTEMS, LLC.**  
 8502 N.W. 80th STREET  
 MEDLEY, FL. 33166  
 TEL. (305) 885-5299 FAX (305) 885-5902

no	date	description	by
A	01.16.14	REV. PER PER COMMENTS	REV. PER PER COMMENTS
B	06.08.15	UPDATED TO 2014 FBC	REV. PER PER COMMENTS
C	12.01.15	REV. PER PER COMMENTS	REV. PER PER COMMENTS
D	01.11.18	UPDATED TO 2017 FBC	REV. PER PER COMMENTS

date: 09-27-13  
 scale: 1/2"=1'-0"  
 dr. by: TARIQ  
 chk. by:

drawing no.  
**W13-49**  
 sheet 2 of 12

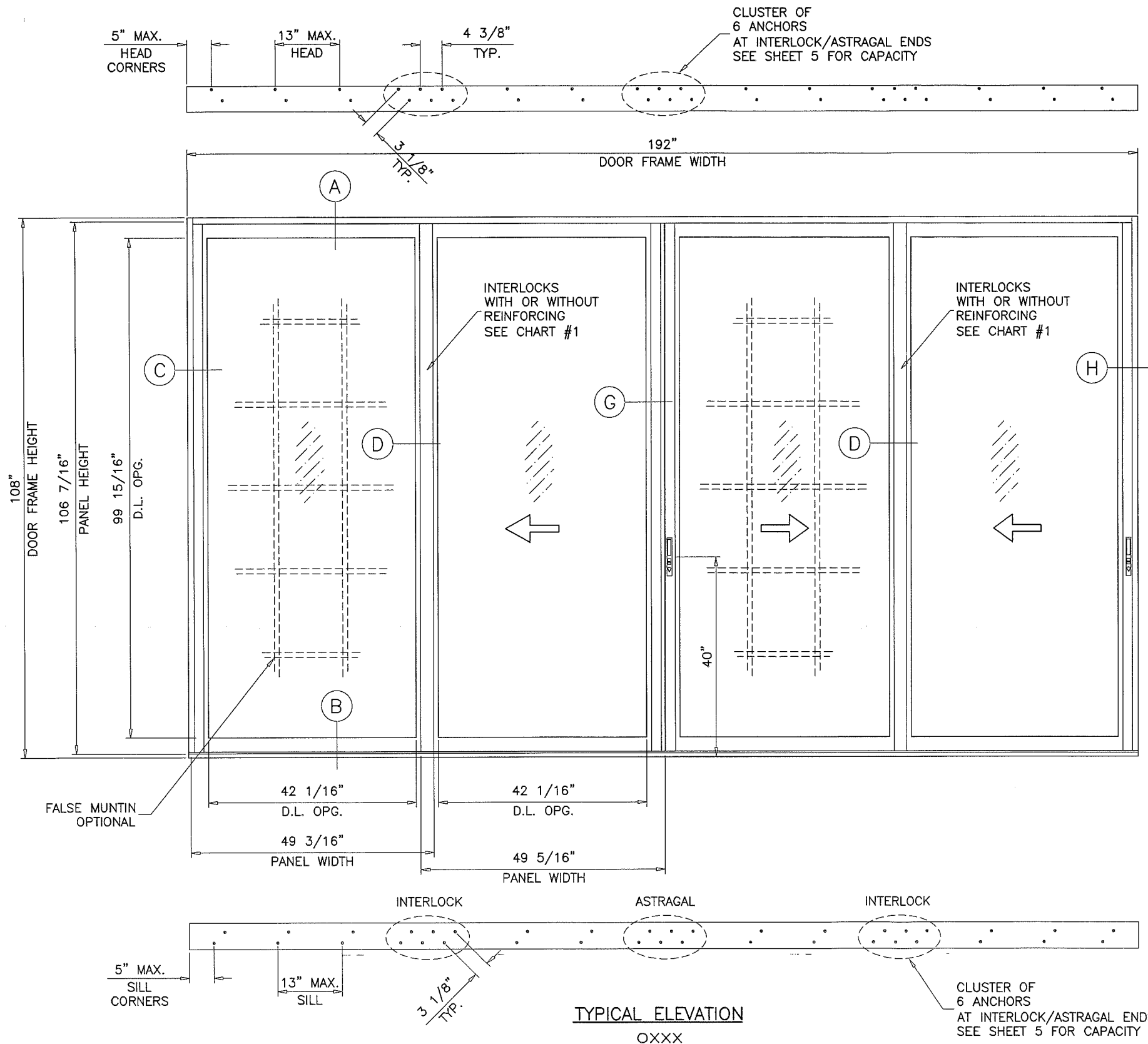

TYPICAL ELEVATION  
OXXX

ALTERNATE SIZE UNITS:  
MAX. FRAME AREA OF DOORS NOT TO EXCEED  
THE TESTED FRAME AREA OF 144 SQ. FT.

PRODUCT REVIEWED  
as complying with the Florida  
Building Code  
Acceptance No. 18-1220-09  
Expiration Date 3/20/24  
By *Isheq I. Chaudhry*  
Alum. Slide Product Control

PRODUCT REVIEWED  
as complying with the Florida  
Building Code  
Acceptance No. 18-0129-13  
Expiration Date 3/20/19  
By *Isheq I. Chaudhry*  
Alum. Slide Product Control

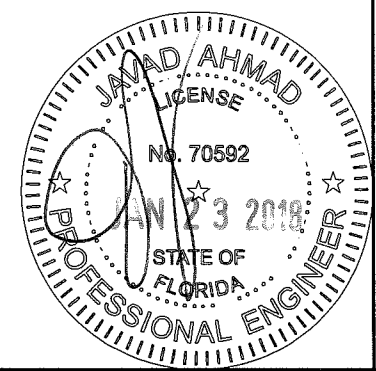

**af c**  
**AL-FAROOQ CORPORATION**  
ENGINEERS & PRODUCT DEVELOPMENT  
9360 SUNSET DRIVE, SUITE 220  
MIAMI, FLORIDA 33173 (C.A.N. 3538)  
TEL. (305) 264-8100 FAX. (305) 262-6978  
COMP-ANL\W13-49ECO

SERIES-700 ALUM SLIDING GLASS DOOR (L.M.I.)  
**ECO WINDOW SYSTEMS, LLC.**  
8502 N.W. 80th STREET  
MEDLEY, FL 33166  
TEL. (305) 885-5299 FAX (305) 885-5902

no	date	by	description
A	01.16.14	REV. PER RER COMMENTS	REV. PER RER COMMENTS
B	06.08.15	UPDATED TO 2014 FBC	UPDATED TO 2014 FBC
C	12.01.15	REV. PER RER COMMENTS	REV. PER RER COMMENTS
D	01.11.18	UPDATED TO 2017 FBC	UPDATED TO 2017 FBC

date: 09-27-13  
scale: 1/2"=1'-0"  
dr. by: TARIQ  
chk. by:  
drawing no.  
**W13-49**  
sheet 3 of 12

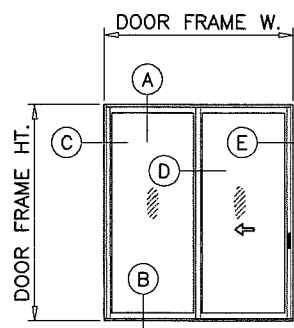

OX (SHOWN)  
XO  
XX

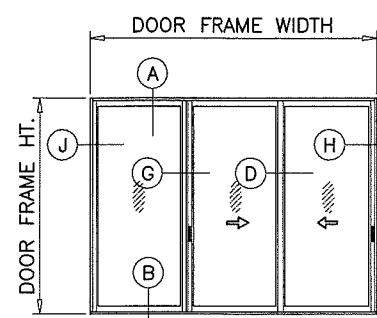

OXX (SHOWN)  
XXO

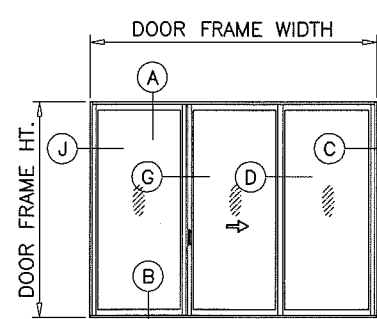

O XO (SHOWN)

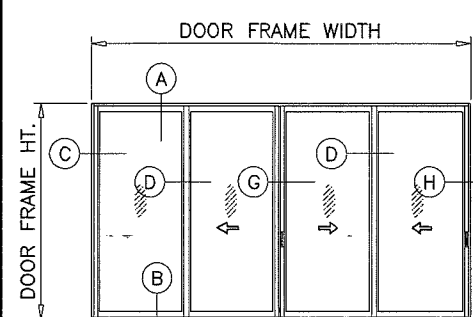

OXXX (SHOWN)  
OXXO  
XXXX

APPROVED CONFIGURATIONS

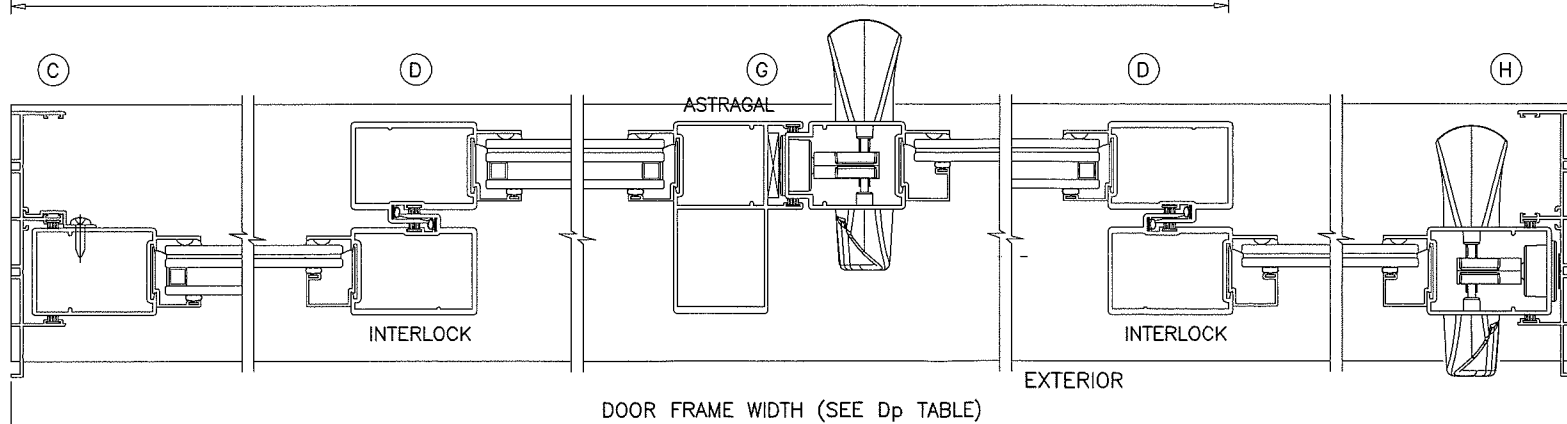
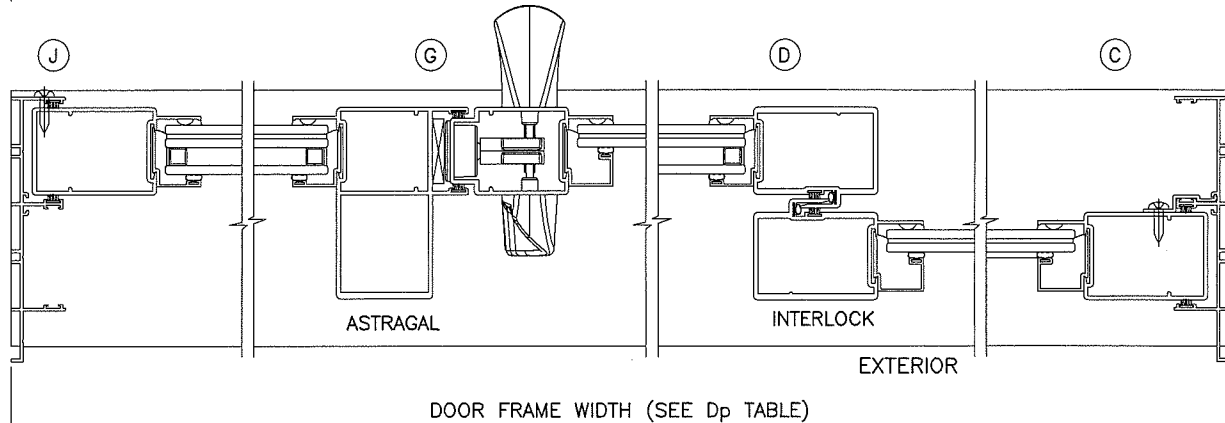
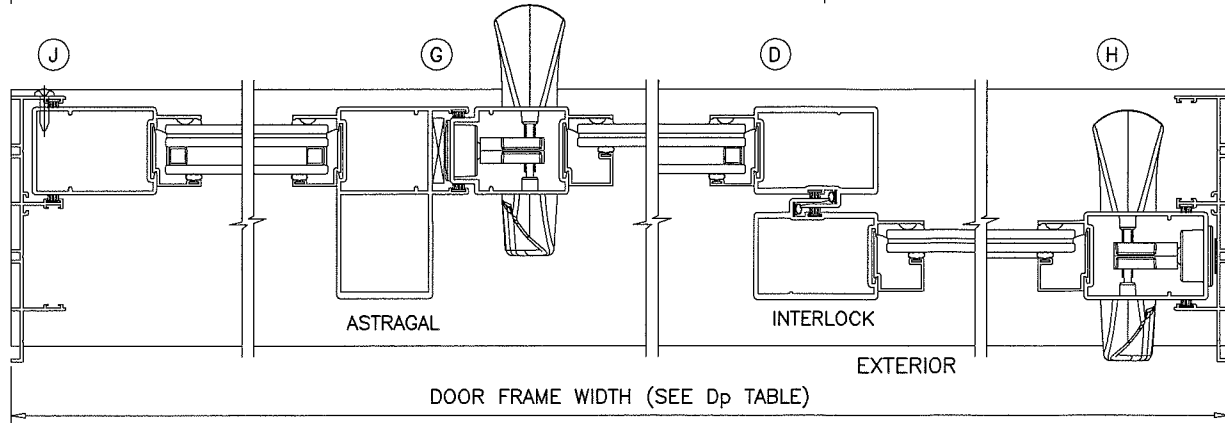
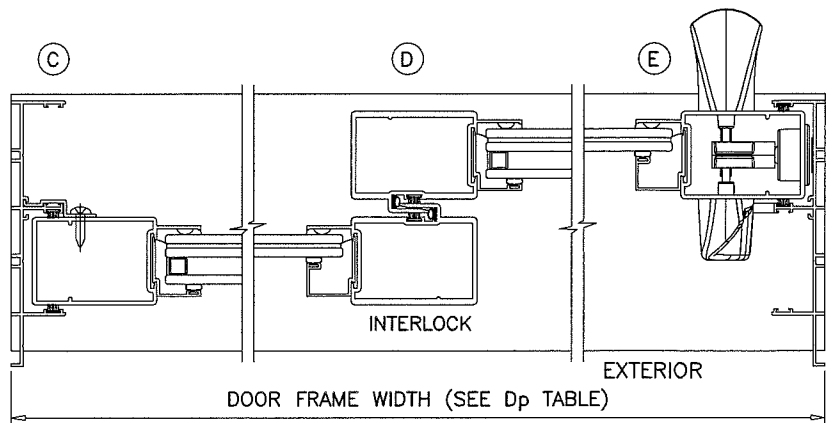

- NOTE:
1. CONFIGURATIONS SHOWN FOR ILLUSTRATION PURPOSES ONLY.
  2. FOR APPLICABLE DESIGN PRESSURES AND REINFORCEMENTS REQUIREMENTS SEE SHEET 5.
  3. FOR ANCHOR DETAILS SEE SHEETS 7 THRU 9.

**PRODUCT REVISED**  
as complying with the Florida  
Building Code  
Acceptance No 18-1220-09  
Expiration Date 3/20/24  
By Shaykh I. Chaudhry  
Miami Door Product Control

**PRODUCT REVISED**  
as complying with the Florida  
Building Code  
Acceptance No 18-0129-13  
Expiration Date 3/20/19  
By Shaykh I. Chaudhry  
Miami Door Product Control

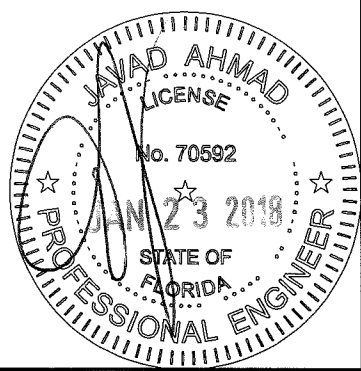

**af c**  
**AL-FAROOQ CORPORATION**  
ENGINEERS & PRODUCT DEVELOPMENT  
9360 SUNSET DRIVE, SUITE 220  
MIAMI, FLORIDA 33173 (C.A.N. 3538)  
TEL. (305) 264-8100 FAX. (305) 262-6978  
COMP-ANL\W13-49ECO

SERIES-700 ALUM SLIDING GLASS DOOR (L.M.I.)  
**ECO WINDOW SYSTEMS, LLC.**  
8502 N.W. 80th STREET  
MEDLEY, FL. 33166  
TEL. (305) 885-5299 FAX (305) 885-5902

no	date	by	description
A	01.16.14	REV. PER PER COMMENTS	REV. PER PER COMMENTS
B	06.08.15	UPDATED TO 2014 FBC	UPDATED TO 2014 FBC
C	12.01.15	REV. PER PER COMMENTS	REV. PER PER COMMENTS
D	01.11.18	UPDATED TO 2017 FBC	UPDATED TO 2017 FBC

date: 09-27-13  
scale: 1/2"=1'-0"  
dr. by: TARIQ  
chk. by:

drawing no.  
**W13-49**  
sheet 4 of 12

CHART #1

DESIGN LOAD CAPACITY - PSF (GLASS)					
AVERAGE PANEL WIDTH INCHES	DOOR FRAME HEIGHT INCHES	GLASS TYPES 'B', 'B1'		GLASS TYPES 'A', 'A1'	
		WITHOUT REINF.		WITH REINF.	
		EXT.(+)	INT.(-)	EXT.(+)	INT.(-)
30	82	70.0	80.0	70.0	80.0
36		70.0	80.0	70.0	80.0
42		70.0	80.0	70.0	80.0
48		70.0	80.0	70.0	80.0
54		62.2	71.1	62.2	71.1
30	84	70.0	80.0	70.0	80.0
36		70.0	80.0	70.0	80.0
42		70.0	80.0	70.0	80.0
48		70.0	80.0	70.0	80.0
54		62.2	71.1	62.2	71.0
30	90	70.0	80.0	70.0	80.0
36		70.0	80.0	70.0	80.0
42		70.0	80.0	70.0	80.0
48		70.0	80.0	70.0	80.0
54		-	-	62.2	71.1
30	96	70.0	80.0	70.0	80.0
36		70.0	80.0	70.0	80.0
42		70.0	80.0	70.0	80.0
48		70.0	80.0	70.0	80.0
54		-	-	62.2	71.1
30	98	70.0	80.0	70.0	80.0
36		70.0	80.0	70.0	80.0
42		70.0	80.0	70.0	80.0
48		70.0	80.0	70.0	80.0
54		-	-	62.2	71.1
30	102	-	-	70.0	80.0
36		-	-	70.0	80.0
42		-	-	70.0	80.0
48		-	-	70.0	80.0
54		-	-	70.0	80.0
30	108	-	-	70.0	80.0
36		-	-	70.0	80.0
42		-	-	70.0	80.0
48		-	-	70.0	80.0
54		-	-	70.0	80.0

CHART #2

LOAD CAPACITY - PSF (ANCHORS)					
AVERAGE PANEL WIDTH INCHES	DOOR FRAME HEIGHT INCHES	6 ANCHORS AT MTG. STILE ENDS			
		EXT.(+)		INT.(-)	
		EXT.(+)	INT.(-)	EXT.(+)	INT.(-)
30	82	70.0	80.0	70.0	80.0
36		70.0	80.0	70.0	80.0
42		70.0	80.0	70.0	80.0
48		70.0	80.0	70.0	80.0
54		62.2	71.1	62.2	71.1
30	84	70.0	80.0	70.0	80.0
36		70.0	80.0	70.0	80.0
42		70.0	80.0	70.0	80.0
48		70.0	80.0	70.0	80.0
54		62.2	71.1	62.2	71.1
30	90	70.0	80.0	70.0	80.0
36		70.0	80.0	70.0	80.0
42		70.0	80.0	70.0	80.0
48		70.0	80.0	70.0	80.0
54		62.2	71.1	62.2	71.1
30	96	70.0	80.0	70.0	80.0
36		70.0	80.0	70.0	80.0
42		70.0	80.0	70.0	80.0
48		70.0	80.0	70.0	80.0
54		62.2	71.1	62.2	71.1
30	98	70.0	80.0	70.0	80.0
36		70.0	80.0	70.0	80.0
42		70.0	80.0	70.0	80.0
48		70.0	80.0	70.0	80.0
54		62.2	71.1	62.2	71.1
30	102	70.0	80.0	70.0	80.0
36		70.0	80.0	70.0	80.0
42		70.0	80.0	70.0	80.0
48		70.0	80.0	70.0	80.0
54		62.2	71.1	62.2	71.1
30	108	70.0	80.0	70.0	80.0
36		70.0	80.0	70.0	80.0
42		70.0	80.0	70.0	80.0
48		70.0	80.0	70.0	80.0
54		62.2	71.1	62.2	71.1

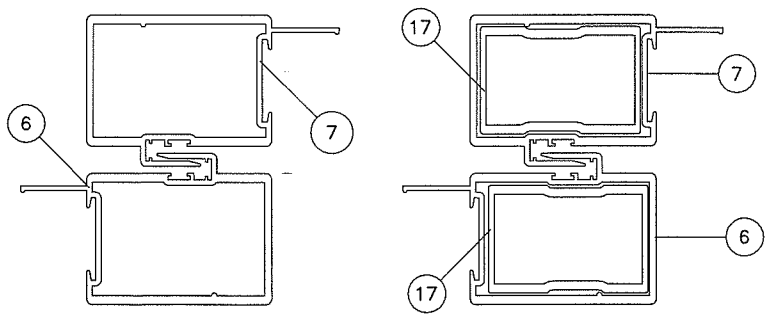
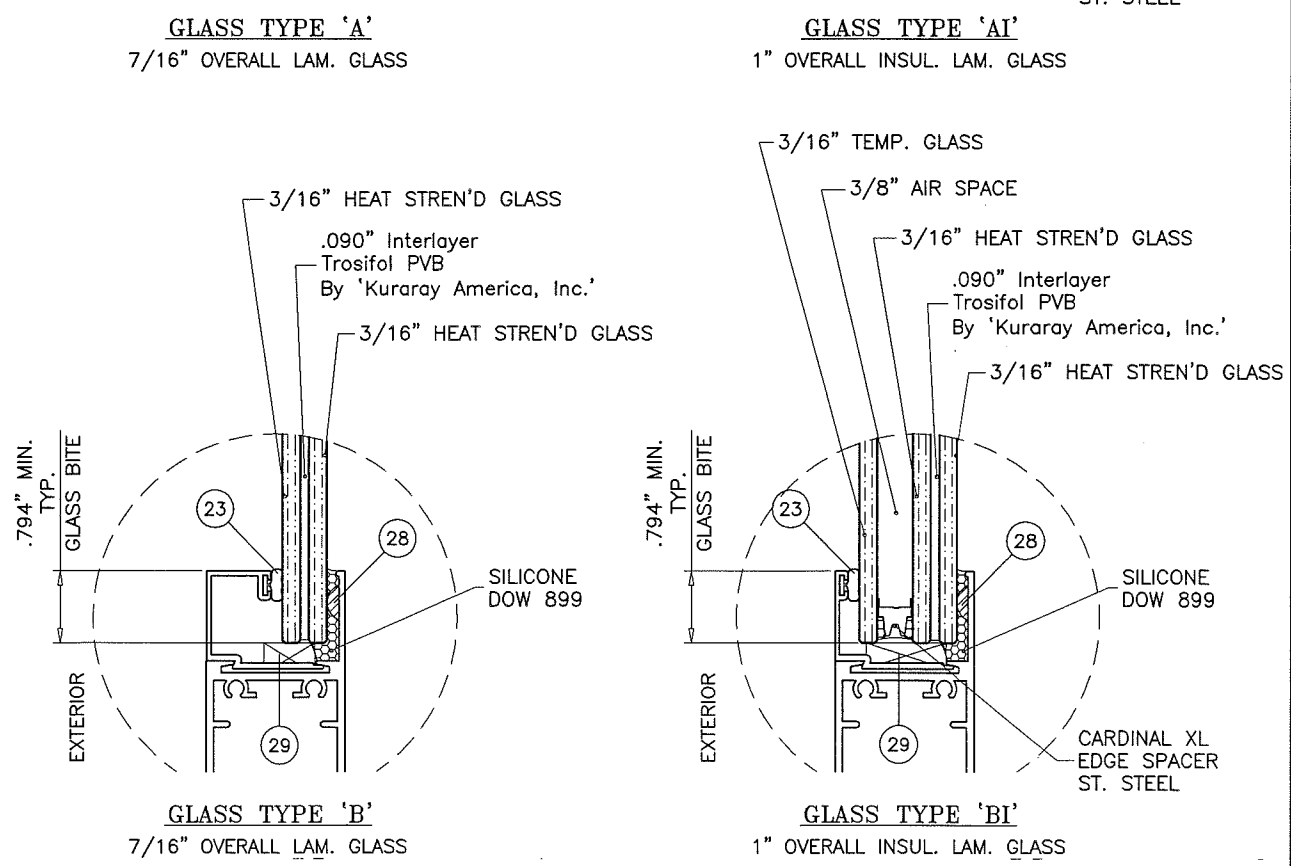
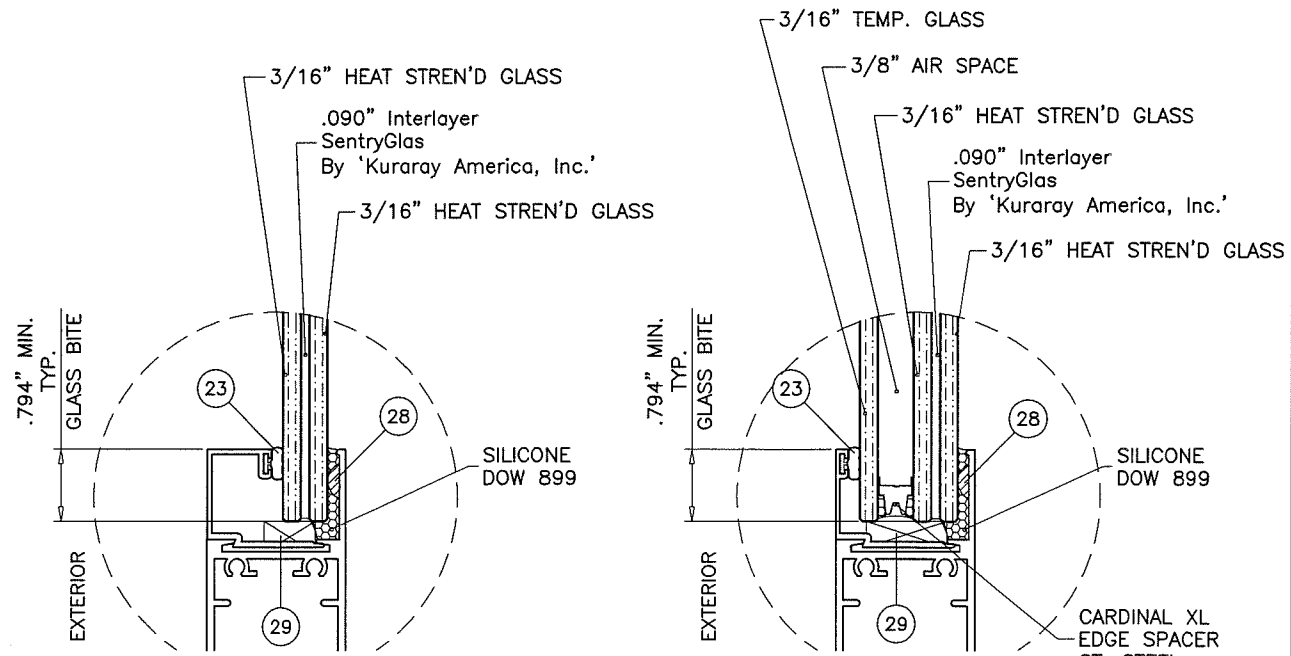

INTERLOCKS WITHOUT REINF. INTERLOCKS WITH REINF.

ALL EXTERIOR(+) LOADS SHOWN IN CHARTS ABOVE ARE FOR DOORS WITH 2-3/4" SILL HEIGHTS. FOR 2" SILL HEIGHT LIMIT EXT.(+) LOADS TO 47.0 PSF DOORS WITH 1-1/8" SILL HEIGHTS ARE NOT APPROVED FOR WATER INFILTRATION RESISTANCE SEE SHEET 7 FOR DETAILS

NOTE: SEE CHART #1 FOR DESIGN LOAD CAPACITY OF DESIRED GLASS SIZE AND REINFORCEMENT. SEE CHART #2 FOR ANCHORS CAPACITY. LOWER VALUES FROM GLASS OR ANCHOR CHART WILL APPLY TO ENTIRE SYSTEM.

NOTE: GLASS CAPACITIES ON THIS SHEET ARE BASED ON ASTM E1300-09 (3 SEC. GUSTS) AND FLORIDA BUILDING COMMISSION DECLARATORY STATEMENT DCA05-DEC-219

**GLAZING OPTIONS**  
 PRODUCT REVISED as complying with the Florida Building Code  
 Acceptance No. 18-1220.09 Expiration Date 3/20/24  
 By Ishag I. Ahmad Miami Dade Product Control  
 PRODUCT REVISED as complying with the Florida Building Code  
 Acceptance No. 18-0129.13 Expiration Date 3/20/19  
 By Ishag I. Ahmad Miami Dade Product Control

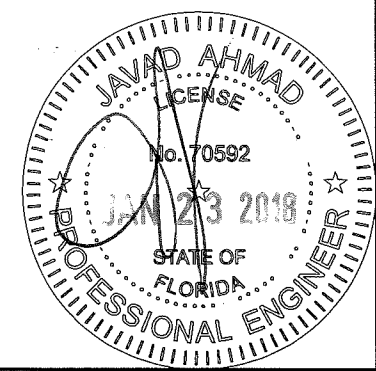

**afC**  
**AL-FAROOQ CORPORATION**  
 ENGINEERS & PRODUCT DEVELOPMENT  
 9360 SUNSET DRIVE, SUITE 220  
 MIAMI, FLORIDA 33173  
 TEL. (305) 264-8100 FAX. (305) 262-6978  
 COMP-ANL\W13-49ECO

SERIES-700 ALUM SLIDING GLASS DOOR (L.M.I.)  
**ECO WINDOW SYSTEMS, LLC.**  
 8502 N.W. 80th STREET  
 MEDLEY, FL. 33166  
 TEL. (305) 885-5299 FAX (305) 885-5902

no	date	description
A	01.16.14	REV. PER PER COMMENTS
B	06.08.15	UPDATED TO 2014 FBC
C	12.01.15	REV. PER PER COMMENTS
D	01.11.18	UPDATED TO 2017 FBC

date: 09-27-13  
 scale: 1/2" = 1"  
 dr. by: TARIQ  
 chk. by:  
 drawing no. **W13-49**  
 sheet 5 of 12



1BY OR 2BY WOOD BUCKS AND METAL STRUCTURE NOT BY ECO WINDOWS  
MUST SUSTAIN LOADS IMPOSED BY GLAZING SYSTEM  
AND TRANSFER THEM TO THE BUILDING STRUCTURE.

**TYPICAL ANCHORS:** SEE ELEV. FOR SPACING

— AT HEAD —

- TYPE 'A'— 1/4" DIA. ULTRACON BY 'ELCO' (Fu=177 KSI, Fy=155 KSI)  
THRU 1BY OR 2BY BUCKS INTO CONCRETE  
1-1/4" MIN. EMBED INTO CONCRETE
- TYPE 'B'— 1/4" DIA. ULTRACON BY 'ELCO' (Fu=177 KSI, Fy=155 KSI)  
DIRECTLY INTO CONCRETE  
1-3/4" MIN. EMBED
- TYPE 'C'— 1/4" DIA. SELF DRILLING SCREWS (GRADE 5 CRS)  
INTO MIAMI-DADE COUNTY APPROVED MULLIONS  
OR  
INTO METAL STRUCTURES  
(3) THREADS MIN. TO EXTEND BEYOND METAL THICKNESS  
ALUMINUM: 1/8" THK. MIN. (6063-T5 MIN.)  
STEEL: 1/8" THK. MIN. (Fy = 36 KSI MIN.)  
(STEEL IN CONTACT WITH ALUMINUM TO BE PLATED OR PAINTED)

— AT SILL —

- TYPE 'B'— 1/4" DIA. ULTRACON BY 'ELCO' (Fu=177 KSI, Fy=155 KSI)  
DIRECTLY INTO CONCRETE  
1-3/4" MIN. EMBED

— AT JAMBS —

- TYPE 'A'— 1/4" DIA. ULTRACON BY 'ELCO' (Fu=177 KSI, Fy=155 KSI)  
INTO 2BY WOOD BUCKS OR WOOD STRUCTURES  
1-1/2" MIN. PENETRATION INTO WOOD  
THRU 1BY BUCKS INTO CONC. OR BLOCKS  
1-1/4" MIN. EMBED INTO CONC. OR BLOCKS
- TYPE 'B'— 1/4" DIA. ULTRACON BY 'ELCO' (Fu=177 KSI, Fy=155 KSI)  
DIRECTLY INTO CONC. OR BLOCKS  
1-1/4" MIN. EMBED INTO CONC. OR BLOCKS
- TYPE 'C'— 1/4" DIA. SELF DRILLING SCREWS (GRADE 5 CRS)  
INTO MIAMI-DADE COUNTY APPROVED MULLIONS  
OR  
INTO METAL STRUCTURES  
(3) THREADS MIN. TO EXTEND BEYOND METAL THICKNESS  
ALUMINUM: 1/8" THK. MIN. (6063-T5 MIN.)  
STEEL: 1/8" THK. MIN. (Fy = 36 KSI MIN.)  
(STEEL IN CONTACT WITH ALUMINUM TO BE PLATED OR PAINTED)

**ANCHOR EDGE DISTANCES**

INTO CONCRETE AND BLOCKS = 2-1/2" MIN.  
INTO WOOD STRUCTURE = 1" MIN.  
INTO METAL STRUCTURE = 3/4" MIN.

WOOD AT HEAD OR JAMBS SG = 0.55 MIN.  
CONCRETE AT HEAD, SILL OR JAMBS f'c = 3000 PSI MIN.  
C-90 HOLLOW/FILLED BLOCK AT JAMBS f'm = 2000 PSI MIN.

**PRODUCT REVISED**  
as complying with the Florida  
Building Code  
Acceptance No. 18-1220-09  
Expiration Date 3/20/24  
By Ishag L. Chanda  
Alum. Glass Product Control

**PRODUCT REVISED**  
as complying with the Florida  
Building Code  
Acceptance No. 18-0129-13  
Expiration Date 3/20/19  
By Ishag L. Chanda  
Alum. Glass Product Control

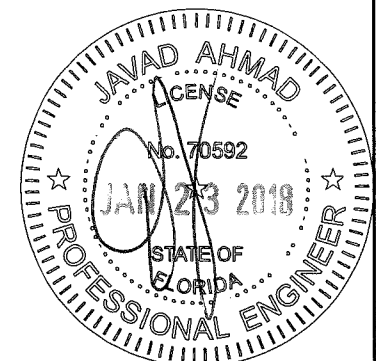

**afc**

**AL-FAROOQ CORPORATION**  
ENGINEERS & PRODUCT DEVELOPMENT  
9360 SUNSET DRIVE, SUITE 220  
MIAMI, FLORIDA 33173 (C.A.N. 3538)  
TEL. (305) 264-8100 FAX. (305) 262-6978  
COMP-ANL\W13-49ECO

SERIES-700 ALUM SLIDING GLASS DOOR (L.M.I.)  
**ECO WINDOW SYSTEMS, LLC.**  
8502 N.W. 80th STREET  
MEDLEY, FL. 33166  
TEL. (305) 885-5299 FAX (305) 885-5902

revisions:		no	date	by	description
A	01.16.14				REV. PER PER COMMENTS
B	06.08.15				UPDATED TO 2014 FBC
C	12.01.15				REV. PER PER COMMENTS
D	01.11.18				UPDATED TO 2017 FBC

date: 09-27-13  
scale: 1/2" = 1"  
dr. by: TARIQ  
chk. by:

drawing no.  
**W13-49**  
sheet 6 of 12

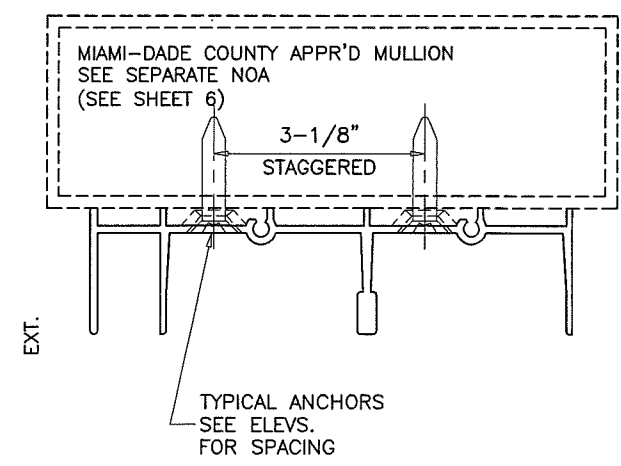
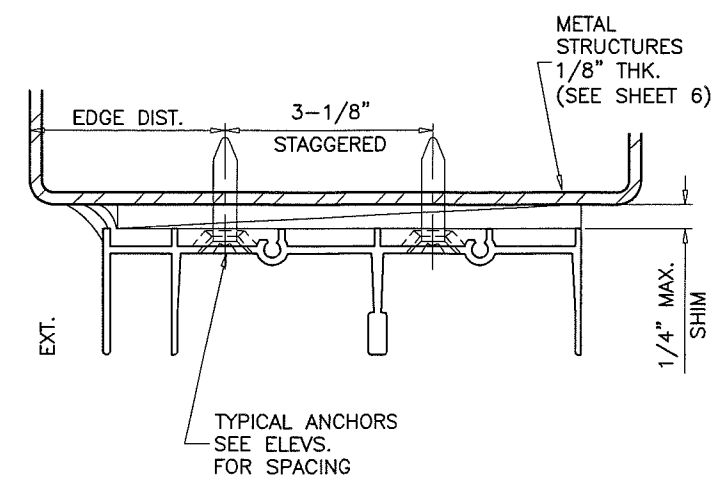
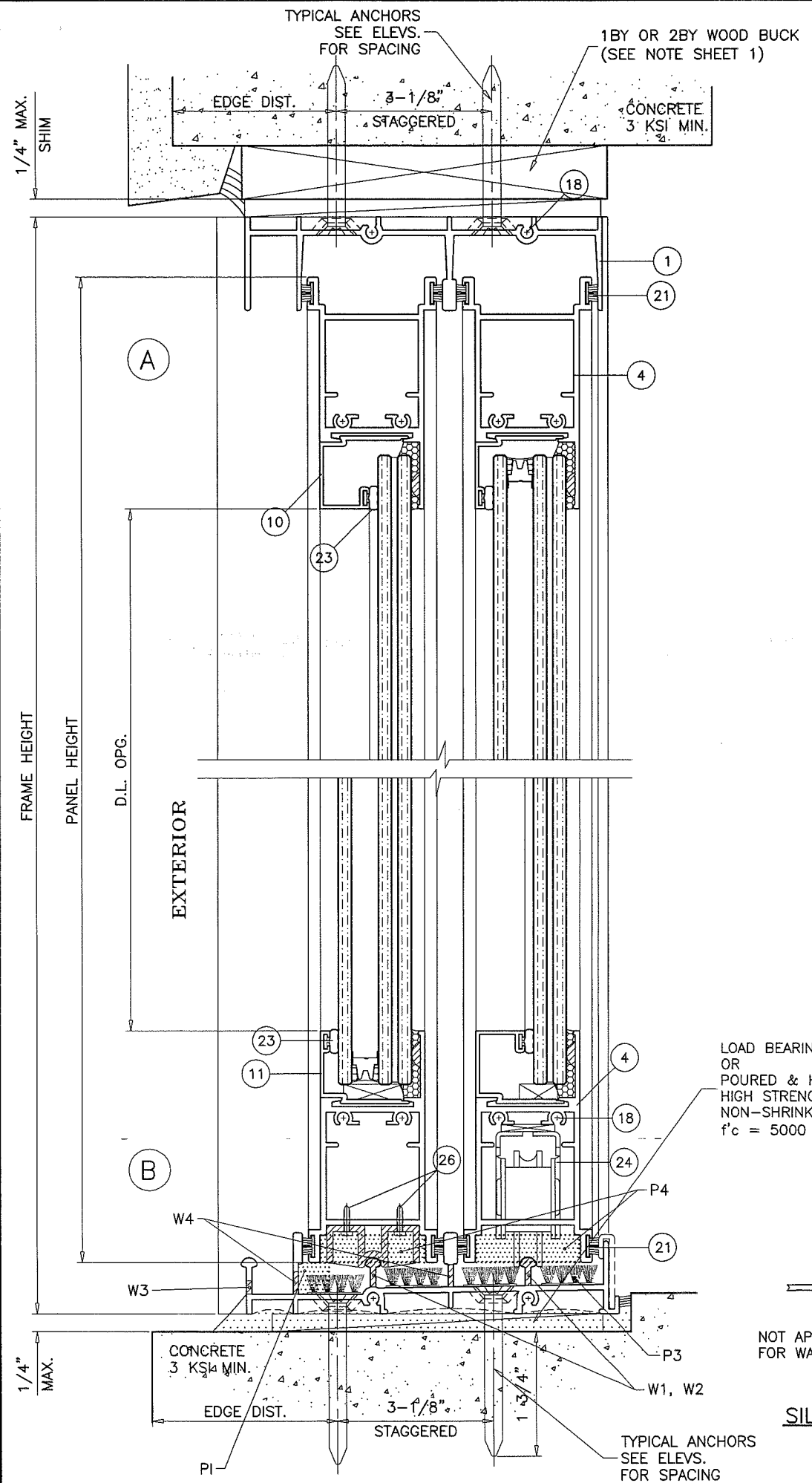

LOAD BEARING SHIMS OR  
POURED & HARDENED  
HIGH STRENGTH GROUT  
NON-SHRINK, NON-METALLIC  
f'c = 5000 PSI MIN.

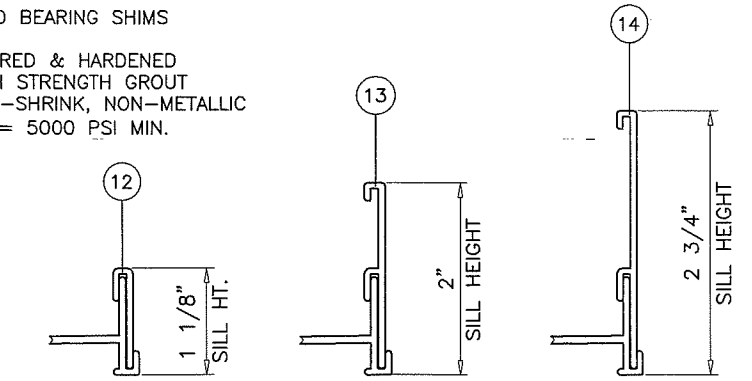

**SILL HEIGHT VS WATER RESISTANCE EXT.(+) LOAD**  
SEE SHEET 5 CHART 1 FOR DOOR CAPACITY

**WEEPHOLES:**

- W1 = 1-1/2" LONG NOTCH AT EACH END.
- W2 = 3/16" X 3/4" LONG WEEP NOTCH AT 22" FROM ENDS AND 36" O.C.
- W3 = 3/16" X 1" LONG WEEP NOTCH AT 5" FROM ENDS AND 36" O.C.
- W4 = 1/4" X 1" LONG WEEP NOTCH AT 5" FROM ENDS AND 36" O.C.

**PILE PADS:**

- P1 = OPEN CELL FOAM AT EACH WEEP HOLE LOCATION  
1-1/16" LONG X 7/16" WIDE X 7/16" HIGH
- P2 = SELF ADHESIVE PILE PAD  
1" X 3/8" X 1/4" HIGH
- P3 = SELF ADHESIVE PILE PAD WITH MULTI INTEGRAL FIN  
2-1/2" X 1" X 3/8" HIGH
- P4 = OPEN CELL FOAM AT INTERLOCK & ASTRAGAL  
2" LONG X 1-7/16" WIDE X 7/16" HIGH

**PRODUCT REVIEWED**  
as complying with the Florida  
Building Code  
Acceptance No. 18-1220-09  
Expiration Date 3/20/24  
By: *Ishtay I. Chank*  
Miami Dade Product Control

**PRODUCT REVIEWED**  
as complying with the Florida  
Building Code  
Acceptance No. 18-0129-13  
Expiration Date 3/20/19  
By: *Ishtay I. Chank*  
Miami Dade Product Control

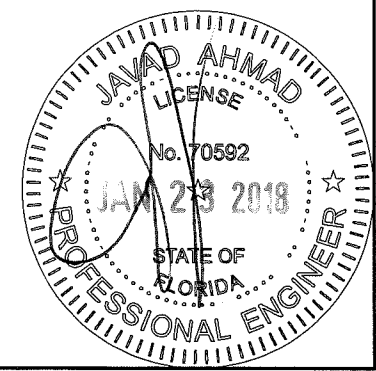

**afC**  
**AL-FAROOQ CORPORATION**  
ENGINEERS & PRODUCT DEVELOPMENT  
9360 SUNSET DRIVE, SUITE 220  
MIAMI, FLORIDA 33173  
TEL. (305) 264-8100 FAX. (305) 262-6978  
COMP-ANL\W13-49ECO

SERIES-700 ALUM SLIDING GLASS DOOR (L.M.I.)  
**ECO WINDOW SYSTEMS, LLC.**  
8502 N.W. 80th STREET  
MEDLEY, FL. 33166  
TEL. (305) 885-5299 FAX (305) 885-5902

no	date	description
A	01.16.14	REV. PER PER COMMENTS
B	06.08.15	UPDATED TO 2014 FBC
C	12.01.15	REV. PER PER COMMENTS
D	01.11.18	UPDATED TO 2017 FBC

date: 09-27-13  
scale: 1/2" = 1"  
dr. by: TARIQ  
chk. by:

drawing no.  
**W13-49**

sheet 7 of 12

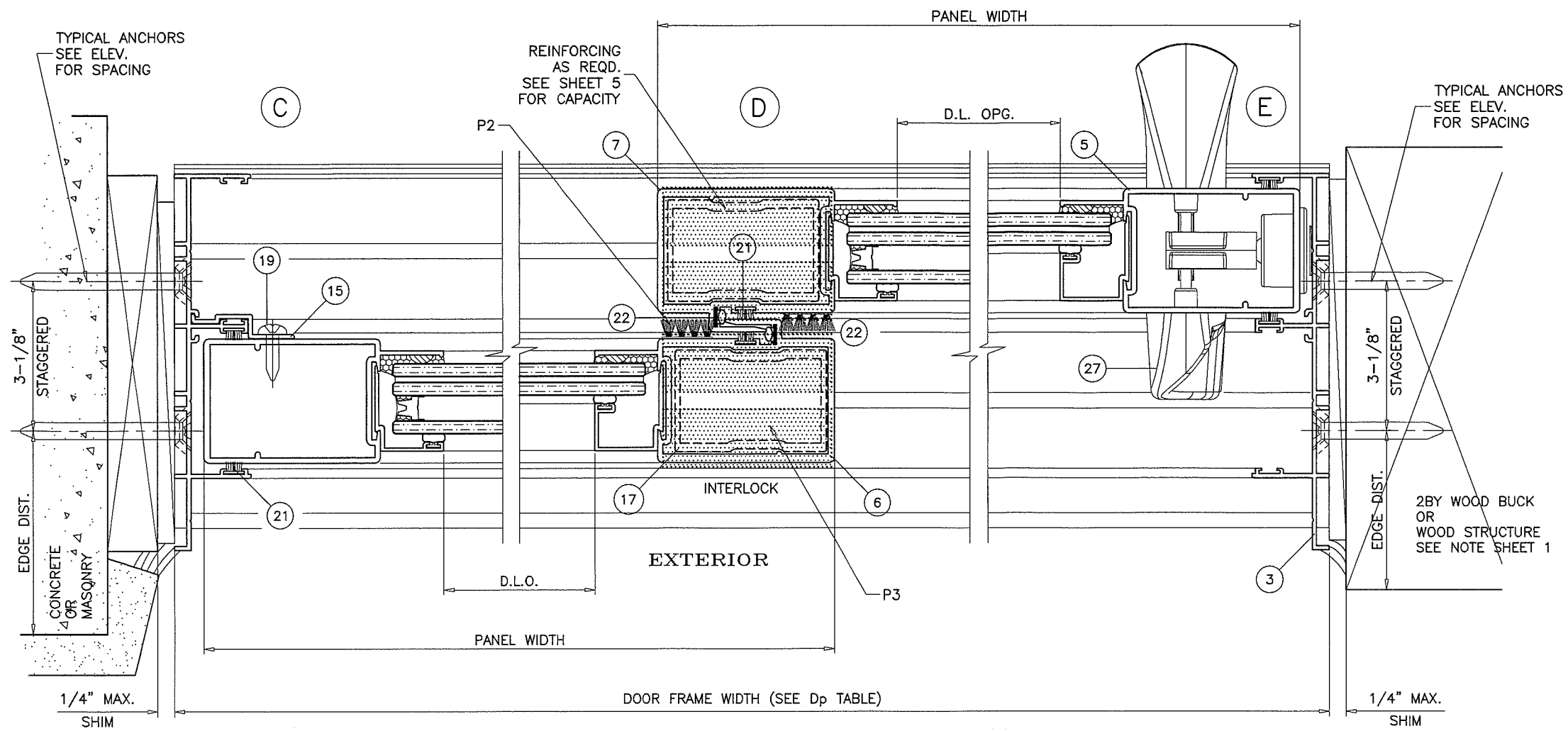

**PRODUCT RENEWED**  
 as complying with the Florida  
 Building Code  
 Acceptance No. 18-1220-09  
 Expiration Date 3/20/24  
 By Ishag I. Chaudhry  
 Miami Desk Product Control

**PRODUCT REVISED**  
 as complying with the Florida  
 Building Code  
 Acceptance No. 18-0129.13  
 Expiration Date 3/20/19  
 By Ishag I. Chaudhry  
 Miami Desk Product Control

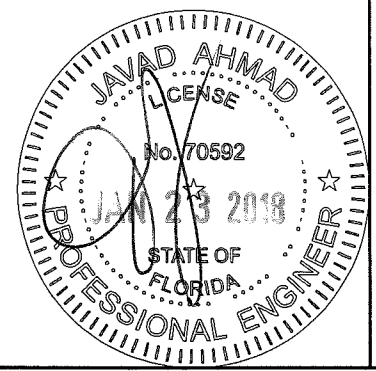

**af c**  
**AL-FAROOQ CORPORATION**  
 ENGINEERS & PRODUCT DEVELOPMENT  
 9360 SUNSET DRIVE, SUITE 220 (C.A.N. 3538)  
 MIAMI, FLORIDA 33173  
 TEL. (305) 264-8100 FAX. (305) 262-6978  
 COMP-ANL W13-49ECO

SERIES-700 ALUM SLIDING GLASS DOOR (L.M.I.)  
**ECO WINDOW SYSTEMS, LLC.**  
 8502 N.W. 80th STREET  
 MEDLEY, FL. 33166  
 TEL. (305) 885-5299 FAX (305) 885-5902

no	date	description
A	01.16.14	REV. PER RER COMMENTS
B	06.08.15	UPDATED TO 2014 FBC
C	12.01.15	REV. PER RER COMMENTS
D	01.11.18	UPDATED TO 2017 FBC

date: 09-27-13  
 scale: 1/2" = 1"  
 dr. by: TARIQ  
 chk. by:

drawing no.  
**W13-49**  
 sheet 8 of 12

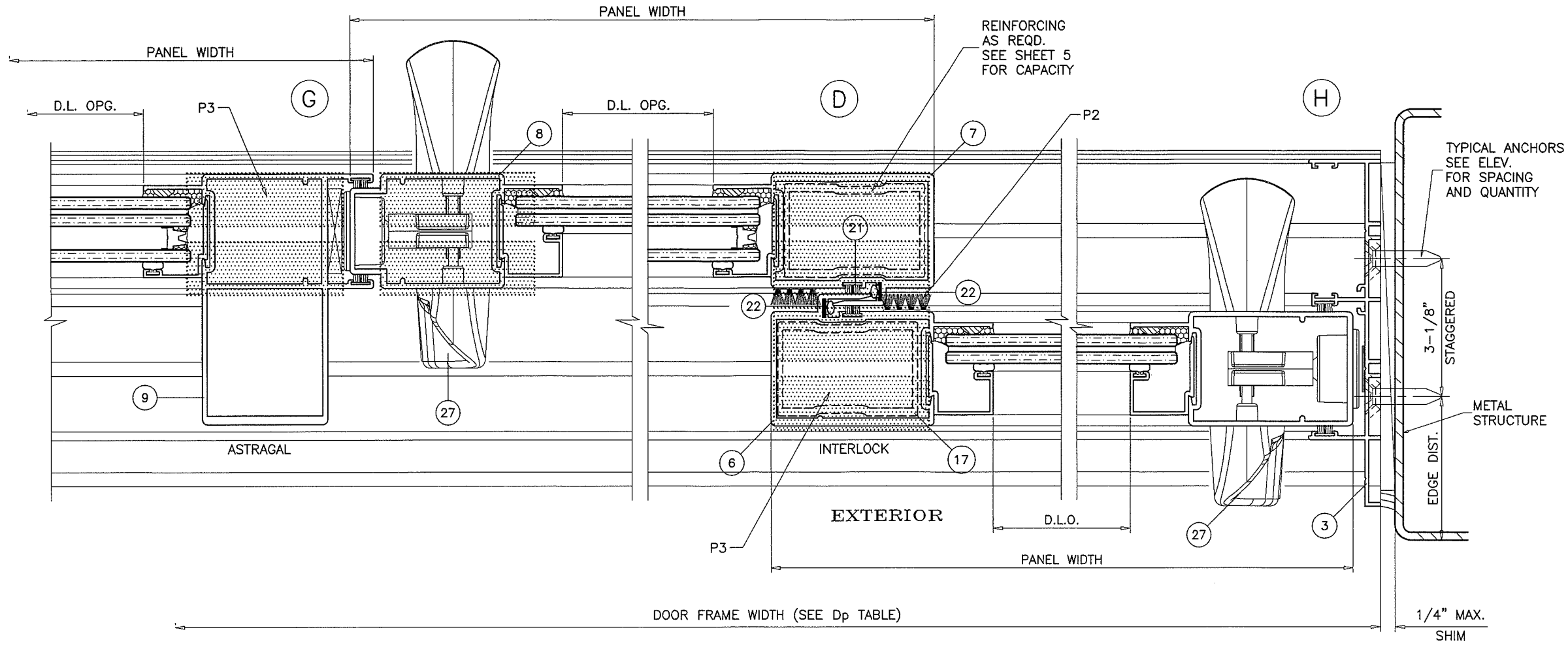

REINFORCING  
AS REQD.  
SEE SHEET 5  
FOR CAPACITY

TYPICAL ANCHORS  
SEE ELEV.  
FOR SPACING  
AND QUANTITY

DOOR FRAME WIDTH (SEE Dp TABLE)

1/4" MAX.  
SHIM

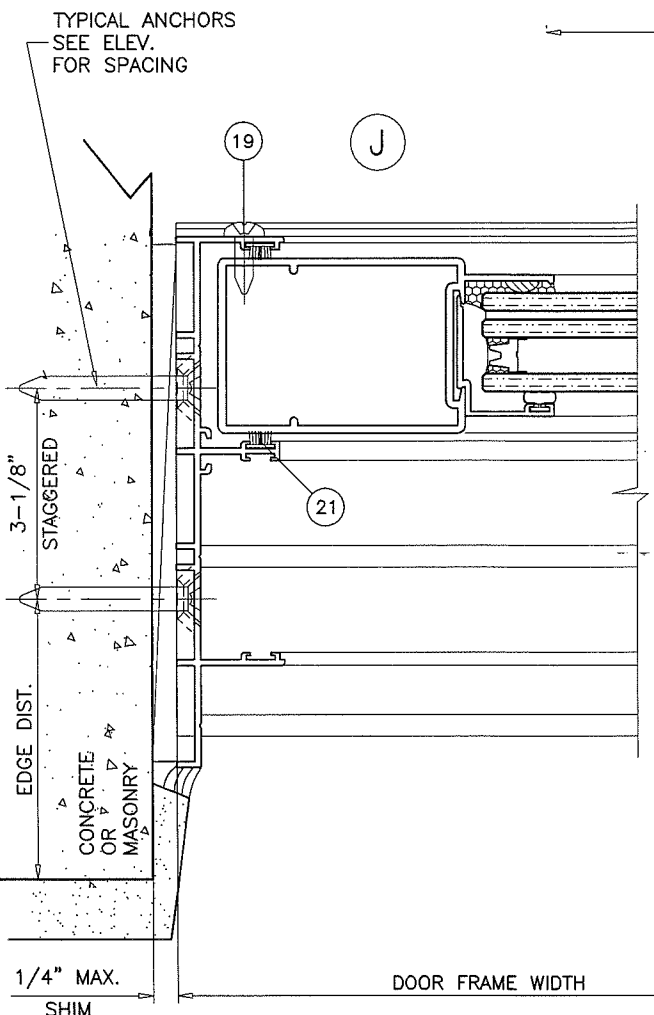

**PRODUCT REVISION**  
as complying with the Florida  
Building Code  
Acceptance No. 18-1220.6.9  
Expiration Date 3/20/21  
By *Michael J. Chang*  
Miami Dade Product Control

**PRODUCT REVISION**  
as complying with the Florida  
Building Code  
Acceptance No. 18-0129.13  
Expiration Date 3/20/19  
By *Michael J. Chang*  
Miami Dade Product Control

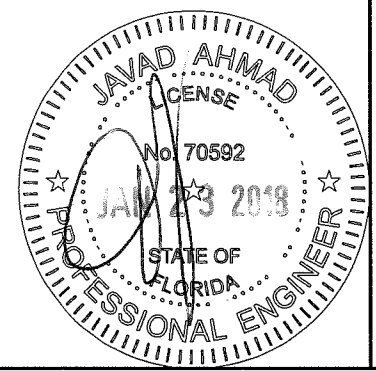

**af c**  
**AL-FAROOQ CORPORATION**  
ENGINEERS & PRODUCT DEVELOPMENT  
9360 SUNSET DRIVE, SUITE 220  
MIAMI, FLORIDA 33173 (C.A.N. 3538)  
TEL. (305) 262-6978 FAX. (305) 262-6978  
COMP-ANL W13-49ECO

SERIES-700 ALUM SLIDING GLASS DOOR (L.M.I.)  
**ECO WINDOW SYSTEMS, LLC.**  
8502 N.W. 80th STREET  
MEDLEY, FL. 33166  
TEL. (305) 885-5299 FAX (305) 885-5902

no	date	by	description
A	01.16.14	REV. PER RER COMMENTS	REV. PER RER COMMENTS
B	06.08.15	REV. PER RER COMMENTS	UPDATED TO 2014 FBC
C	12.01.15	REV. PER RER COMMENTS	REV. PER RER COMMENTS
D	01.11.18	REV. PER RER COMMENTS	UPDATED TO 2017 FBC

date: 09-27-13  
scale: 1/2" = 1"  
dr. by: TARIQ  
chk. by:

drawing no.  
**W13-49**  
sheet 9 of 12

ITEM #	PART #	QUANTITY	DESCRIPTION	MATERIAL	MANF./SUPPLIER/REMARKS
1	E701	1	FRAME HEAD	6005-T5	-
2	E702	1	FRAME SILL	6005-T5	-
3	E703	2	FRAME JAMB	6063-T6	-
4	E704	2/ PANEL	PANEL TOP AND BOTTOM RAIL	6063-T6	-
5	E705	AS REQD.	PANEL LOCK STILE	6063-T6	-
6	E706	AS REQD.	PANEL OUTER INTERLOCK	6063-T6	-
7	E707	AS REQD.	PANEL INNER INTERLOCK	6063-T6	-
8	E708	AS REQD.	PANEL MALE ASTRAGAL	6063-T6	-
9	E709	AS REQD.	PANEL FEMALE ASTRAGAL	6063-T6	-
10	E710	AS REQD.	GLAZING BEAD 7/16" LAMINATED GLASS	6063-T6	-
11	E711	AS REQD.	GLAZING BEAD 1" INSULATED GLASS	6063-T6	-
12	E712	AS REQD.	SILL TRIM	6063-T6	OPTIONAL
13	E713	AS REQD.	2" SILL RISER	6063-T6	-
14	E714	AS REQD.	2-3/4" SILL RISER	6063-T6	-
15	E715	AS REQD.	FIXED PANEL CLIP (CONTINUOUS)	6063-T6	-
17	E717	AS REQD.	INTERLOCK STIFFENER (FULL PANEL LENGTH)	6063-T6	-
18	#10 X 3/4" HWH SMS	AS REQD.	FRAME ASSY. SCREWS	ST. STEEL	-
18A	#10 X 1" FH SMS	AS REQD.	PANEL ASSY. SCREWS	ST. STEEL	-
19	#8 X 1/2" PH SMS	2/CLIP	FIXED PANEL CLIP SCREWS	ST. STEEL	AT 3" FROM ENDS & 16" O.C.
20	#10 X 1-1/4" PH SMS	1/ ROLLER	ROLLER INST. SCREWS	-	NOT SHOWN
21	WEATHERSTRIP	AS REQD.	FRAME AND PANEL WEATHERSTRIP	-	FIN SEAL .190 HIGH BY ULTRAFAB
22	E235	AS REQD.	INTERLOCK BUMPER BULB	SANTOPRENE	ULTRAFAB
23	E203	AS REQD.	GLAZING BEAD BULB	SANTOPRENE	ULTRAFAB, DUROMETER 65±5
24	PRO3-6005	2/ MOV. PANEL	TANDEM NYLON WHEELS IN ST. STEEL HOUSING	-	INTERLOCK (1/2" MTG. SPACER REQD.)
25	E718	2/PANEL	FIXED PANEL SKATE	DELRIN	-
26	#8 X 1/2" PH SMS	2/CLIP	FIXED PANEL SKATE INST. SCREWS	ST. STEEL	-
27	-	AS REQD.	3 PLY DUAL POINT LOCK ASSEMBLY	-	BY INTERLOCK
28	-	AS REQD.	BUMPON (SILICONE SPACER)	SILICONE	BY FRANK LOWE
29	-	AS REQD.	SETTING BLOCKS AT 1/4 POINTS	EPDM	DUROMETER 80±5 SHORE A

**SEALANT:**

ALL JOINTS AND FRAME CONNECTIONS SEALED WITH WHITE/ALUMINUM COLORED SILICONE.

**PRODUCT REVIEWED**  
 as complying with the Florida  
 Building Code  
 Acceptance No. 18-1220-09  
 Expiration Date 3/20/24  
 By: Ishaq I. Chaudhry  
 Miami-Build Product Control

**PRODUCT REVIEWED**  
 as complying with the Florida  
 Building Code  
 Acceptance No. 18-0129-13  
 Expiration Date 3/20/19  
 By: Ishaq I. Chaudhry  
 Miami-Build Product Control

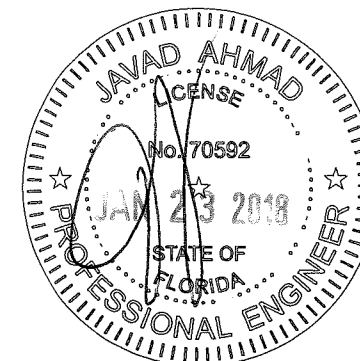

**afC**  
**AL-FAROOQ CORPORATION**  
 ENGINEERS & PRODUCT DEVELOPMENT  
 9360 SUNSET DRIVE, SUITE 220  
 MIAMI, FLORIDA 33173 (C.A.N. 3538)  
 TEL. (305) 264-8100 FAX. (305) 262-6978  
 COMP-ANL W13-49ECCO

SERIES-700 ALUM SLIDING GLASS DOOR (L.M.I.)  
**ECO WINDOW SYSTEMS, LLC.**  
 8502 N.W. 80th STREET  
 MEDLEY, FL. 33166  
 TEL. (305) 885-5299 FAX (305) 885-5902

no	date	by	description
A	01.16.14		REV. PER PER COMMENTS
B	06.08.15		UPDATED TO 2014 FBC
C	12.01.15		REV. PER PER COMMENTS
D	01.11.18		UPDATED TO 2017 FBC

date: 09-27-13  
 scale: 1/2" = 1"  
 dr. by: TARIQ  
 chk. by:

drawing no.  
**W13-49**  
 sheet 10 of 12

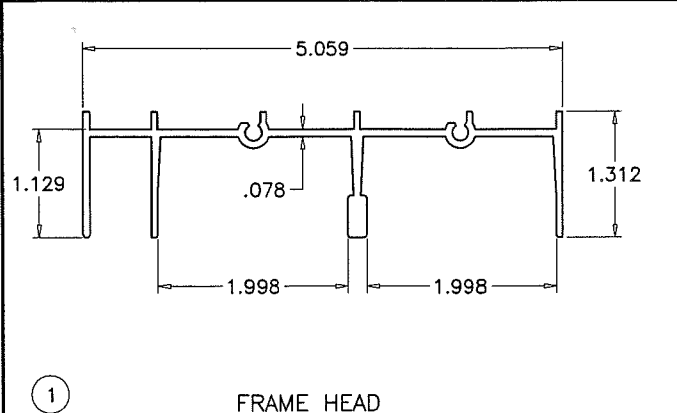

① FRAME HEAD

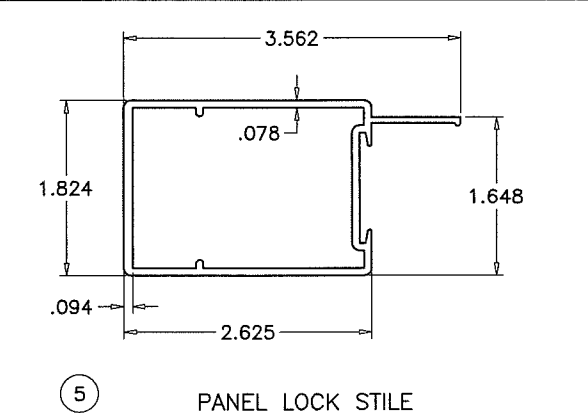

⑤ PANEL LOCK STILE

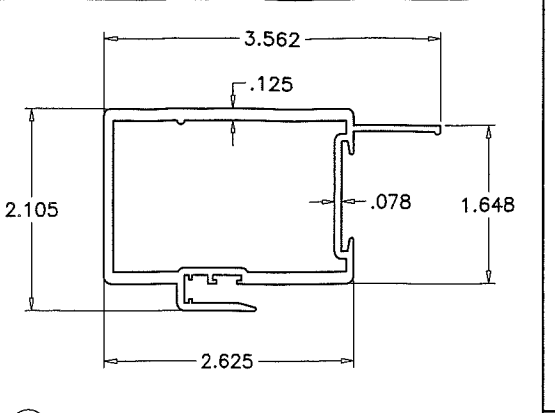

⑦ PANEL INNER INTERLOCK

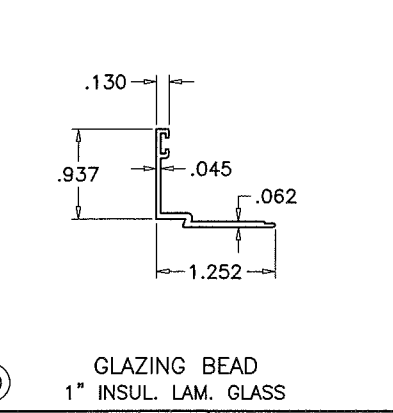

⑩ GLAZING BEAD  
1" INSUL. LAM. GLASS

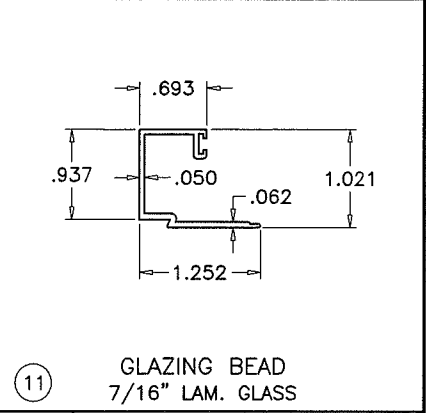

⑪ GLAZING BEAD  
7/16" LAM. GLASS

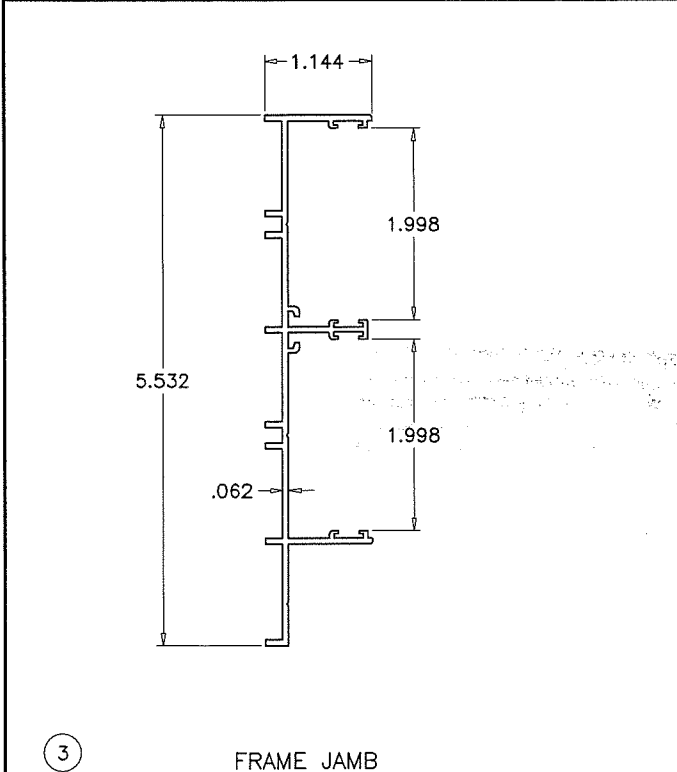

③ FRAME JAMB

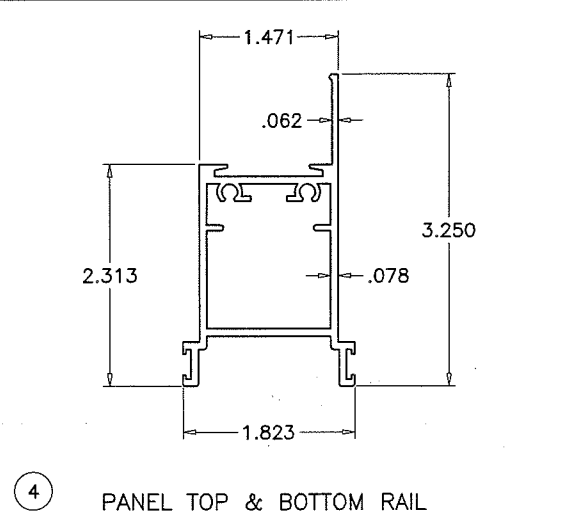

④ PANEL TOP & BOTTOM RAIL

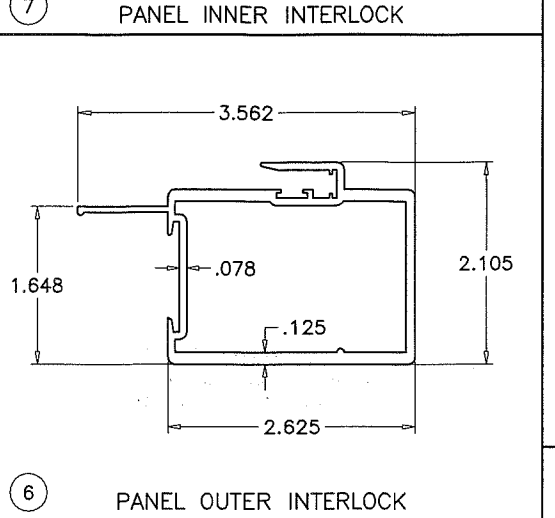

⑥ PANEL OUTER INTERLOCK

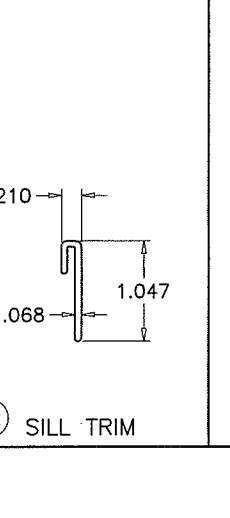

⑫ SILL TRIM

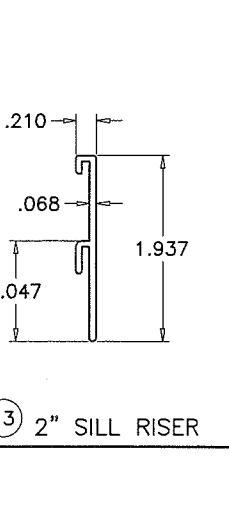

⑬ 2" SILL RISER

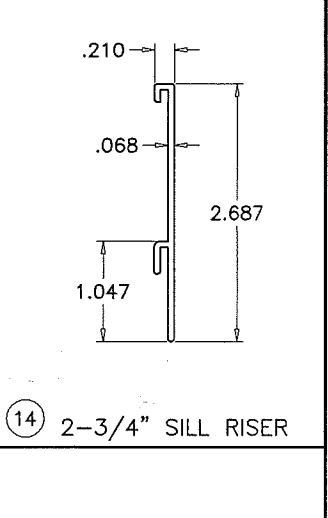

⑭ 2-3/4" SILL RISER

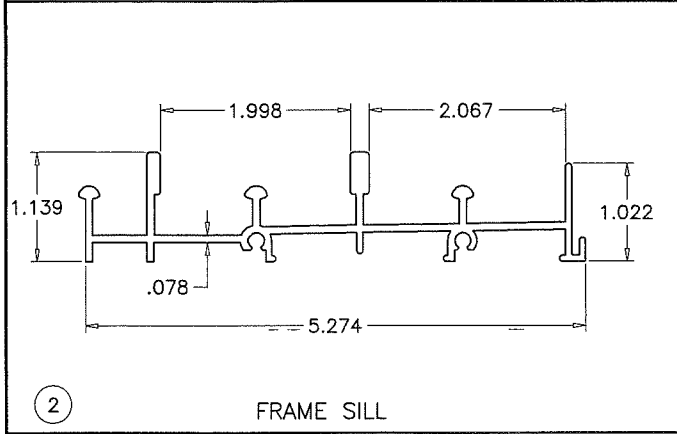

② FRAME SILL

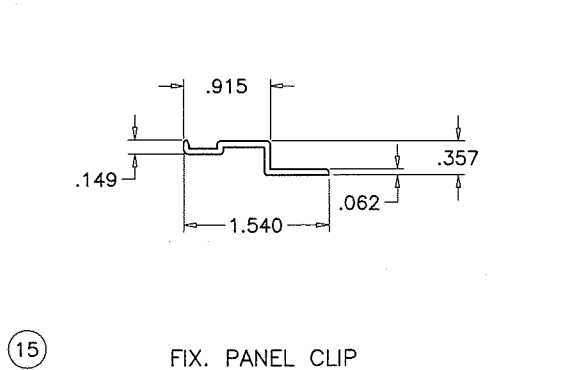

⑮ FIX. PANEL CLIP

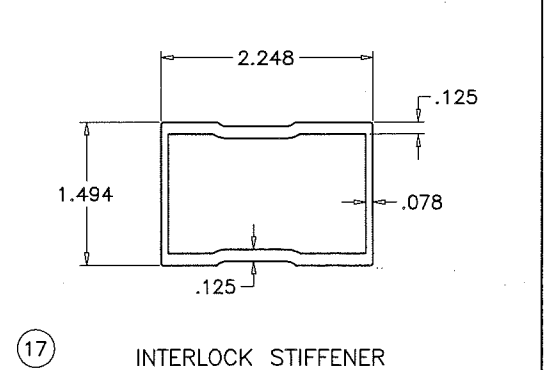

⑰ INTERLOCK STIFFENER

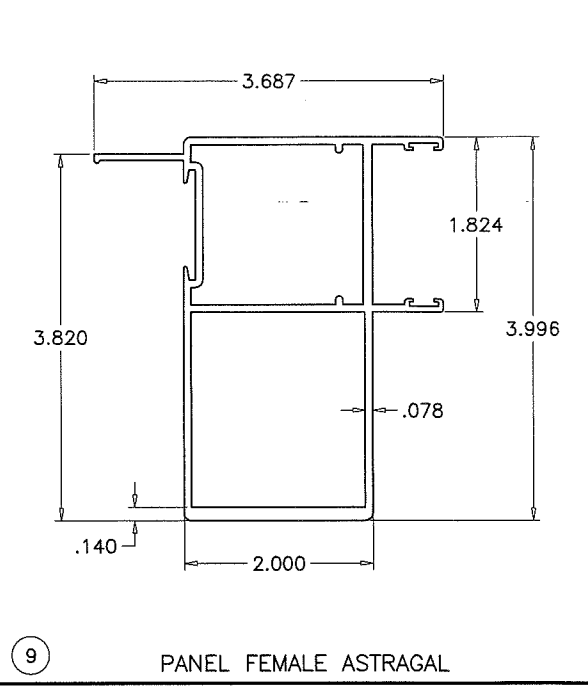

⑨ PANEL FEMALE ASTRAGAL

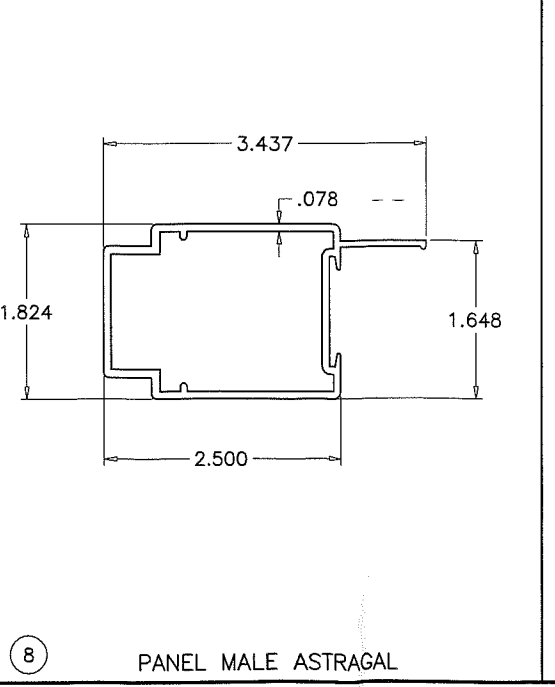

⑧ PANEL MALE ASTRAGAL

PRODUCT REVISED  
as complying with the Florida  
Building Code  
Acceptance No. 18-0129.13  
Expiration Date 3/20/19  
By Ismael L. Chavira  
Senior Code Product Control

PRODUCT RENEWED  
as complying with the Florida  
Building Code  
Acceptance No. 18-1220.09  
Expiration Date 3/20/24  
By Ismael L. Chavira  
Senior Code Product Control

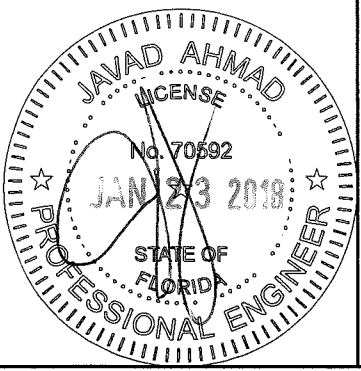

**af c**  
**AL-FAROOQ CORPORATION**  
ENGINEERS & PRODUCT DEVELOPMENT  
9360 SUNSET DRIVE, SUITE 220  
MIAMI, FLORIDA 33173 (C.A.N. 3538)  
TEL. (305) 262-6978 FAX. (305) 264-8100  
COMP-ANL W13-49ECCO

SERIES-700 ALUM SLIDING GLASS DOOR (L.M.I.)  
**ECO WINDOW SYSTEMS, LLC.**  
8502 N.W. 80th STREET  
MEDLEY, FL. 33166  
TEL. (305) 885-5299 FAX (305) 885-5902

no	date	by	description
A	01.16.14	REV. PER PER	COMMENTS
B	06.08.15	UPDATED TO	2014 FBC
C	12.01.15	NO CHANGE	THIS SHEET
D	01.11.18	UPDATED TO	2017 FBC

date: 09-27-13  
scale: 1/2" = 1"  
dr. by: TARIQ  
chk. by:  
drawing no.  
**W13-49**  
sheet 11 of 12

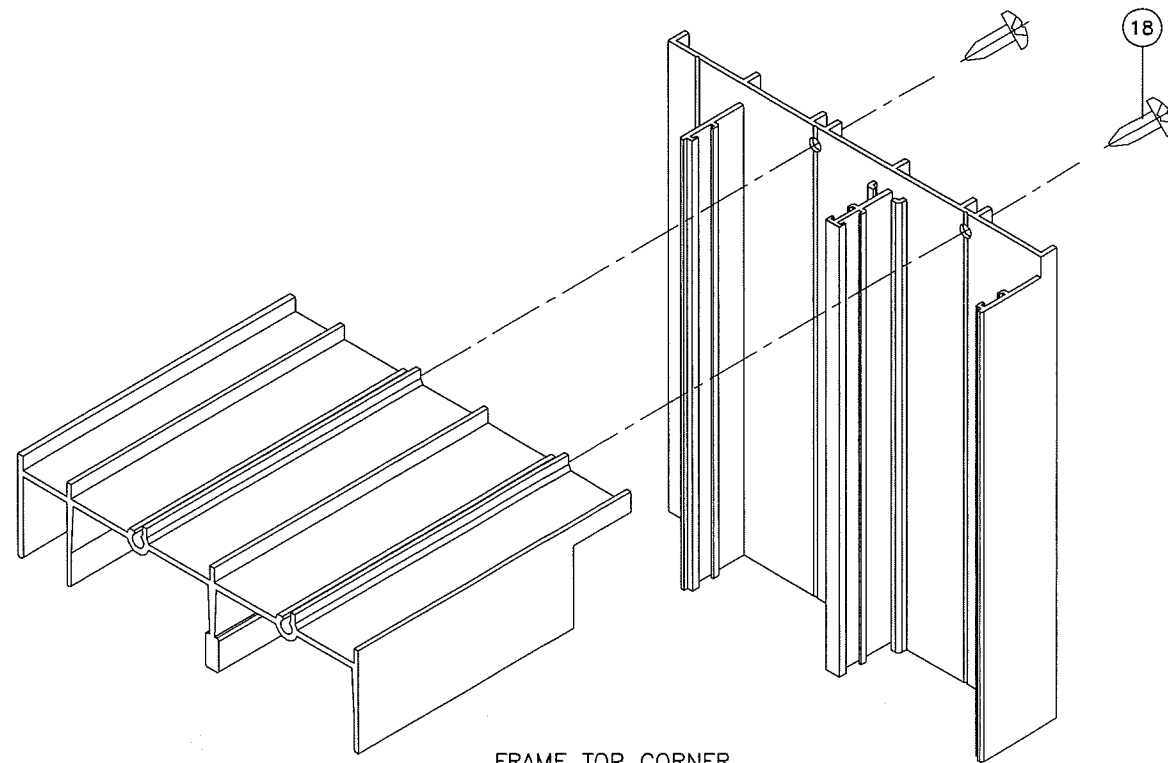

FRAME TOP CORNER

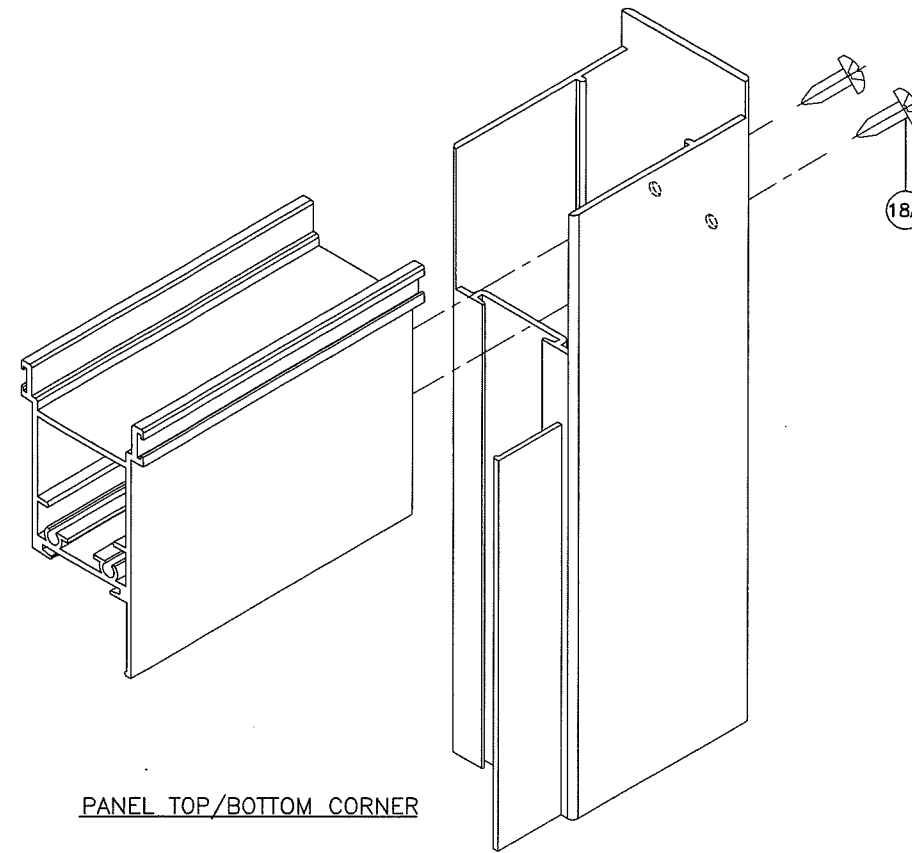

PANEL TOP/BOTTOM CORNER

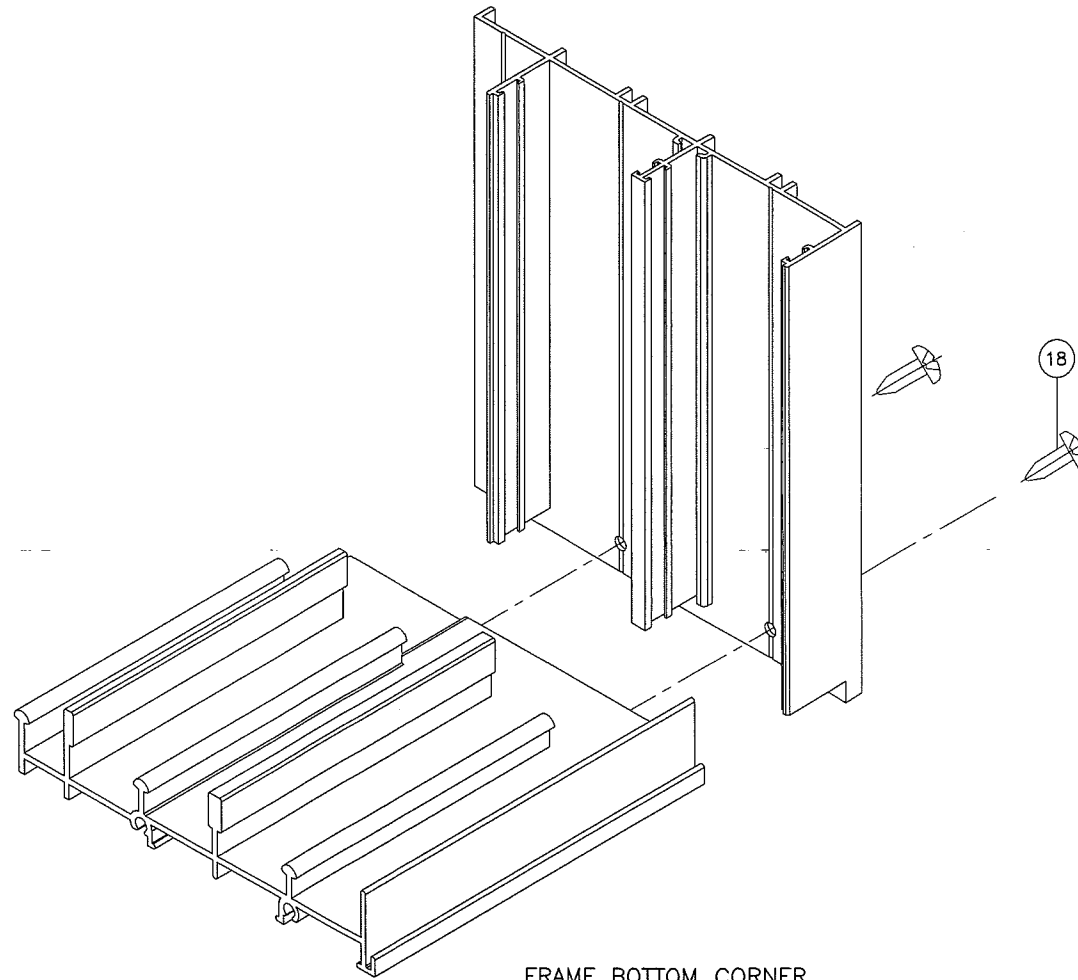

FRAME BOTTOM CORNER

**PRODUCT RENEWED**  
 as complying with the Florida  
 Building Code  
 Acceptance No. 18-1220-09  
 Expiration Date MAR 30, 2024  
 By Kshugl. Chank  
 Miami Code Product Control

**PRODUCT REVISED**  
 as complying with the Florida  
 Building Code  
 Acceptance No. 18-0129-13  
 Expiration Date MAR 30, 2019  
 By Kshugl. Chank  
 Miami Code Product Control

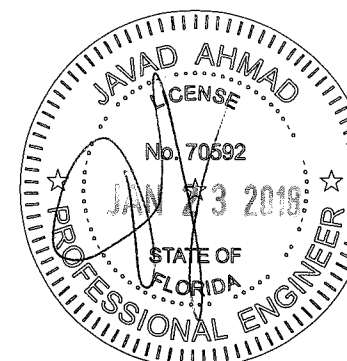

**af c**  
**AL-FAROOQ CORPORATION**  
 ENGINEERS & PRODUCT DEVELOPMENT  
 9360 SUNSET DRIVE, SUITE 220 (C.A.N. 9538)  
 MIAMI, FLORIDA 33173  
 TEL. (305) 264-8100 FAX. (305) 262-6978  
 COMP-ANL W13-49ECO

SERIES-700 ALUM SLIDING GLASS DOOR (L.M.I.)  
**ECO WINDOW SYSTEMS, LLC.**  
 8502 N.W. 80th STREET  
 MEDLEY, FL. 33166  
 TEL. (305) 885-5299 FAX (305) 885-5902

no	date	by	description
A	01.16.14		NO CHANGE THIS SHEET
B	06.08.15		UPDATED TO 2014 FBC
C	12.01.15		NO CHANGE THIS SHEET
D	01.11.18		UPDATED TO 2017 FBC

date: 09-27-13  
 scale: 1/2" = 1"  
 dr. by: TARIQ  
 chk. by:

drawing no.  
**W13-49**  
 sheet 12 of 12