



DEPARTMENT OF REGULATORY AND ECONOMIC RESOURCES (RER)
BOARD AND CODE ADMINISTRATION DIVISION

MIAMI-DADE COUNTY
PRODUCT CONTROL SECTION

11805 SW 26 Street, Room 208
T (786) 315-2590 F (786) 315-2599

NOTICE OF ACCEPTANCE (NOA)

www.miamidade.gov/economy

Eco Window Systems, LLC
8502 NW 80 Street
Medley, FL 33166

SCOPE:

This NOA is being issued under the applicable rules and regulations governing the use of construction materials. The documentation submitted has been reviewed and accepted by Miami-Dade County RER - Product Control Section to be used in Miami Dade County and other areas where allowed by the Authority Having Jurisdiction (AHJ).

This NOA shall not be valid after the expiration date stated below. The Miami-Dade County Product Control Section (In Miami Dade County) and/or the AHJ (in areas other than Miami Dade County) reserve the right to have this product or material tested for quality assurance purposes. If this product or material fails to perform in the accepted manner, the manufacturer will incur the expense of such testing and the AHJ may immediately revoke, modify, or suspend the use of such product or material within their jurisdiction. RER reserves the right to revoke this acceptance, if it is determined by Miami-Dade County Product Control Section that this product or material fails to meet the requirements of the applicable building code.

This product is approved as described herein, and has been designed to comply with the Florida Building Code, including the High Velocity Hurricane Zone.

DESCRIPTION: Series "Eco-Guard 60" Aluminum Horizontal Rolling Window – L.M.I.

APPROVAL DOCUMENT: Drawing No. **W14-11 Rev B**, titled "Eco-Guard Series-60 Alum Horiz. Rolling Wdw. (L.M.I.)", sheets 1 through 5 of 5, dated 03/28/14 and last revised on 10/19/17, prepared by Al-Farooq Corporation, signed and sealed by Javad Ahmad, P.E., bearing the Miami-Dade County Product Control Renewal stamp with the Notice of Acceptance number and expiration date by the Miami-Dade County Product Control Section.

MISSILE IMPACT RATING: Large and Small Missile Impact Resistant

LABELING: Each unit shall bear a permanent label with the manufacturer's name or logo, city, state, model/series, and following statement: "Miami-Dade County Product Control Approved", unless otherwise noted herein.

RENEWAL of this NOA shall be considered after a renewal application has been filed and there has been no change in the applicable building code negatively affecting the performance of this product.

TERMINATION of this NOA will occur after the expiration date or if there has been a revision or change in the materials, use, and/or manufacture of the product or process. Misuse of this NOA as an endorsement of any product, for sales, advertising or any other purposes shall automatically terminate this NOA. Failure to comply with any section of this NOA shall be cause for termination and removal of NOA.

ADVERTISEMENT: The NOA number preceded by the words Miami-Dade County, Florida, and followed by the expiration date may be displayed in advertising literature. If any portion of the NOA is displayed, then it shall be done in its entirety.

INSPECTION: A copy of this entire NOA shall be provided to the user by the manufacturer or its distributors and shall be available for inspection at the job site at the request of the Building Official.

This NOA **renews NOA No. 17-1102.22** and consists of this page 1 and evidence page E-1, E-2 and E-3, as well as approval document mentioned above.

The submitted documentation was reviewed by **Ishaq I. Chanda, P.E.**



3/12/19

NOA No. 19-0219.08
Expiration Date: June 19, 2024
Approval Date: March 21, 2019
Page 1

NOTICE OF ACCEPTANCE: EVIDENCE SUBMITTED

1. EVIDENCE SUBMITTED UNDER PREVIOUS NOA No. 14-0403.09

A. DRAWINGS

1. Manufacturer's die drawings and sections.
2. Drawing No **W14-11**, titled "Eco-Guard Series-60 Alum. Horiz. Rolling Wdw. (L.M.I.)", sheets 1 through 5 of 5, dated 03/28/14, with revision **A** dated 05/23/14, prepared by Al-Farooq Corporation, signed and sealed by Javad Ahmad, P.E.

B. TESTS

1. Test reports on:
 - 1) Air Infiltration Test, per FBC, TAS 202-94
 - 2) Uniform Static Air Pressure Test, Loading per FBC, TAS 202-94
 - 3) Water Resistance Test, per FBC, TAS 202-94
 - 4) Large Missile Impact Test per FBC, TAS 201-94
 - 5) Cyclic Wind Pressure Loading per FBC, TAS 203-94along with marked-up drawings and installation diagram of an Eco-Guard series 60 aluminum horizontal rolling window, prepared by Fenestration Testing Laboratory, Inc., Test Report No. **FTL-7634**, dated 12/09/14, signed and sealed by Marlin Brinson, P.E.

C. CALCULATIONS

1. Anchor verification calculations and structural analysis, complying with **FBC 5th Edition (2014)**, dated 03/19/14, prepared by Al-Farooq Corporation, signed and sealed by Javad Ahmad, P.E.
2. Glazing complies with **ASTM E1300-09**

D. QUALITY ASSURANCE

1. Miami-Dade Department of Regulatory and Economic Resources (RER)

E. MATERIAL CERTIFICATIONS

1. Notice of Acceptance No. **13-0129.27** issued to **E.I. DuPont DeNemours & Co., Inc.** for their "**DuPont Butacite® PVB Interlayer**" dated 04/11/13, expiring on 12/11/16.
2. Notice of Acceptance No. **12-1231.09** issued to **Eastman Chemical Company (MA)** for their "**Saflex HP Clear or Color Glass Interlayers**" dated 03/28/13, expiring on 04/14/18.

F. STATEMENTS

1. Statement letter of conformance, complying with **FBC-5th Edition (2014)**, and of no financial interest, dated March 31, 2014, issued by Al-Farooq Corporation, signed and sealed by Javad Ahmad, P.E.

G. OTHER

1. None.

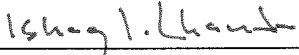

Ishaq I. Chanda, P.E.
Product Control Unit Supervisor
NOA No. 19-0219.08
Expiration Date: June 19, 2024
Approval Date: March 21, 2019

NOTICE OF ACCEPTANCE: EVIDENCE SUBMITTED

2. EVIDENCE SUBMITTED UNDER PREVIOUS NOA #17-1102.22

A. DRAWINGS

1. Drawing No **W14-11**, titled "Eco-Guard Series-60 Alum. Horiz. Rolling Wdw. (L.M.I.)", sheets 1 through 5 of 5, dated 03/28/14, with revision **B** dated 10/19/17, prepared by Al-Farooq Corporation, signed and sealed by Javad Ahmad, P.E.

B. TESTS

1. None.

C. CALCULATIONS

1. None.

D. QUALITY ASSURANCE

1. Miami-Dade Department of Regulatory and Economic Resources (RER)

E. MATERIAL CERTIFICATIONS

1. Notice of Acceptance No. **17-0712.05** issued to **Eastman Chemical Company (MA)** for their "**Saflex Clear and Color Glass Interlayers**" dated 09/07/17, expiring on 05/21/21.
2. Notice of Acceptance No. **16-1117.01** issued to **Kuraray America, Inc.** for their "**Trosifol® Ultraclear, Clear and Color PVB Interlayers**" dated 01/19/17, expiring on 07/08/19.

F. STATEMENTS

1. Statement letter of conformance, complying with **FBC 5th Edition (2014)**, with **FBC 6th Edition (2017)**, and of no financial interest, dated October 12, 2017, issued by Al-Farooq Corporation, signed and sealed by Javad Ahmad, P.E.

G. OTHER

1. Notice of Acceptance No. **14-0910.09**, issued to Eco Window Systems, LLC for their Series "Eco-Guard 60" Aluminum Horizontal Rolling Window -L.M.I., approved on 06/19/14 and expiring on 06/19/19.

3. NEW EVIDENCE SUBMITTED

A. DRAWINGS

1. Drawing No. **W14-11 Rev B**, titled "Eco-Guard Series-60 Alum Horiz. Rolling Wdw. (L.M.I.)", sheets 1 through 5 of 5, dated 03/28/14 and last revised on 10/19/17, prepared by Al-Farooq Corporation, signed and sealed by Javad Ahmad, P.E.

B. TESTS

1. None.



Ishaq I. Chanda, P.E.
Product Control Unit Supervisor
NOA No. 19-0219.08
Expiration Date: June 19, 2024
Approval Date: March 21, 2019

NOTICE OF ACCEPTANCE: EVIDENCE SUBMITTED

C. CALCULATIONS

1. None.

D. QUALITY ASSURANCE

1. Miami-Dade Department of Regulatory and Economic Resources (RER)

E. MATERIAL CERTIFICATIONS

1. Notice of Acceptance No. **17-0712.05** issued to **Eastman Chemical Company (MA)** for their "**Saflex Clear and Color Glass Interlayers**" dated 09/07/17, expiring on 05/21/21.
2. Notice of Acceptance No. **16-1117.01** issued to **Kuraray America, Inc.** for their "**Trosifol® Ultraclear, Clear and Color PVB Interlayers**" dated 01/19/17, expiring on 07/08/19.

F. STATEMENTS

1. Statement letter of conformance, complying with **FBC 6th Edition (2017)**, dated February 07, 2019, issued by Al-Farooq Corporation, signed and sealed by Javad Ahmad, P.E.

G. OTHER

1. Notice of Acceptance No. **17-1102.22**, issued to Eco Window Systems, LLC for their Series "Eco-Guard 60" Aluminum Horizontal Rolling Window -L.M.I., expiring on 06/19/19.



Ishaq I. Chanda, P.E.
Product Control Unit Supervisor
NOA No. 19-0219.08
Expiration Date: June 19, 2024
Approval Date: March 21, 2019

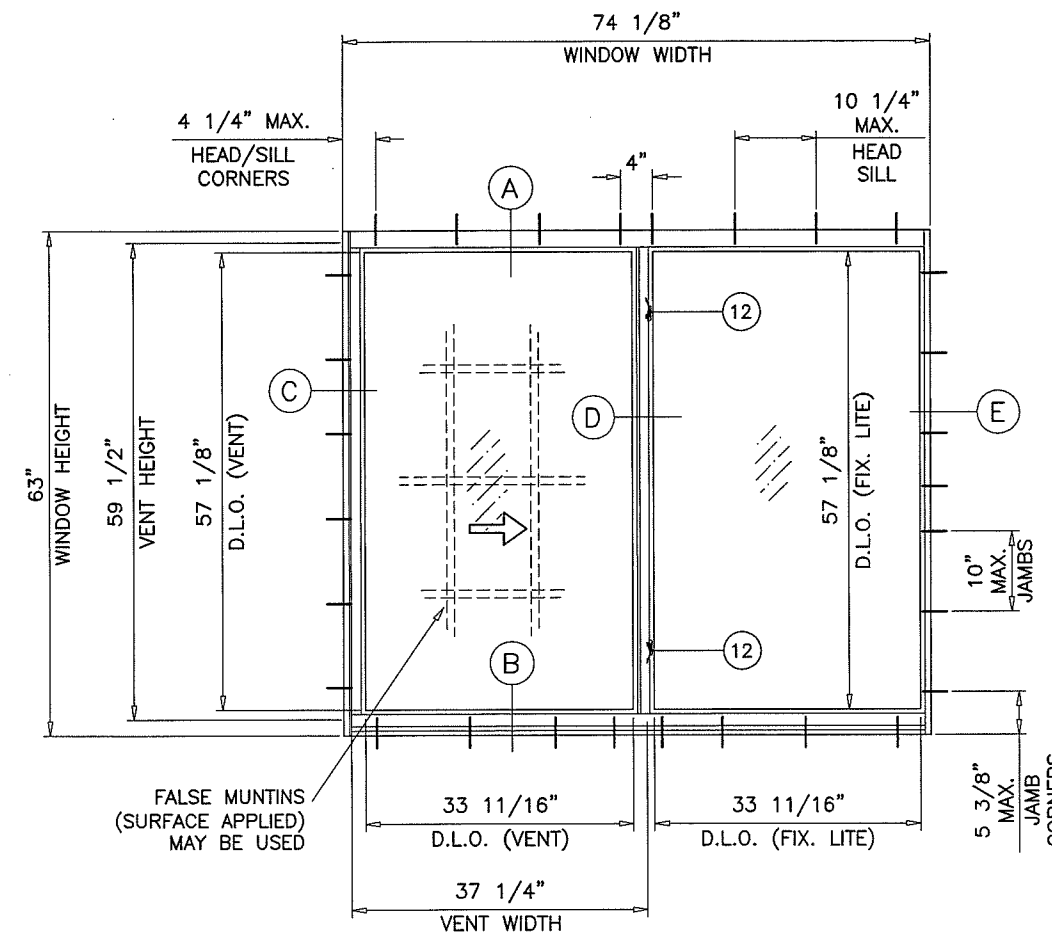

TYPICAL ELEVATION

THESE WINDOWS ARE RATED FOR LARGE & SMALL MISSILE IMPACT. SHUTTERS ARE NOT REQUIRED.

MAXIMUM DESIGN LOAD RATING = + 55.0 PSF
 (FOR SIZES SHOWN ABOVE OR SMALLER) - 60.0 PSF

ECO-GUARD SERIES-60
ALUMINUM HORIZONTAL ROLLING WINDOW

APPROVAL APPLIES TO SINGLE UNITS OR SIDE BY SIDE COMBINATIONS OF H.R./H.R. OR HORIZONTAL ROLLING WITH OTHER WINDOW TYPES IN MODULES OF TWO OR MORE WINDOWS USING MIAMI-DADE COUNTY APPROVED MULLIONS IN BETWEEN. LOWER DESIGN PRESSURE FROM WINDOWS OR MULLION APPROVAL WILL APPLY TO ENTIRE SYSTEM.

THIS PRODUCT HAS BEEN DESIGNED AND TESTED TO COMPLY WITH THE REQUIREMENTS OF THE 2014 (5TH EDITION)/2017 (6TH EDITION) FLORIDA BUILDING CODE INCLUDING HIGH VELOCITY HURRICANE ZONE (HVHZ).

1BY OR 2BY WOOD BUCKS & BUCK FASTENERS BY OTHERS, MUST BE DESIGNED AND INSTALLED ADEQUATELY TO TRANSFER APPLIED PRODUCT LOADS TO THE BUILDING STRUCTURE.

ANCHORS SHALL BE CORROSION RESISTANT, SPACED AS SHOWN ON DETAILS AND INSTALLED PER MANUF'S INSTRUCTIONS. SPECIFIED EMBEDMENT TO BASE MATERIAL SHALL BE BEYOND WALL DRESSING OR STUCCO.

A LOAD DURATION INCREASE IS USED IN DESIGN OF ANCHORS INTO WOOD ONLY.

ALL SHIMS TO BE HIGH IMPACT, NON-METALLIC AND NON-COMPRESSIBLE.

MATERIALS INCLUDING BUT NOT LIMITED TO STEEL/METAL SCREWS, THAT COME INTO CONTACT WITH OTHER DISSIMILAR MATERIALS SHALL MEET THE REQUIREMENTS OF THE 2014/2017 FLORIDA BLDG. CODE & ADOPTED STANDARDS.

THIS PRODUCT APPROVAL IS GENERIC AND DOES NOT PROVIDE INFORMATION FOR A SITE SPECIFIC PROJECT, i.e. LIFE SAFETY OF THIS PRODUCT, ADEQUACY OF STRUCTURE RECEIVING THIS PRODUCT AND SEALING AROUND OPENING FOR WATER INFILTRATION RESISTANCE ETC. CONDITIONS NOT SHOWN IN THIS DRAWING ARE TO BE ANALYZED SEPARATELY, AND TO BE REVIEWED BY BUILDING OFFICIAL.

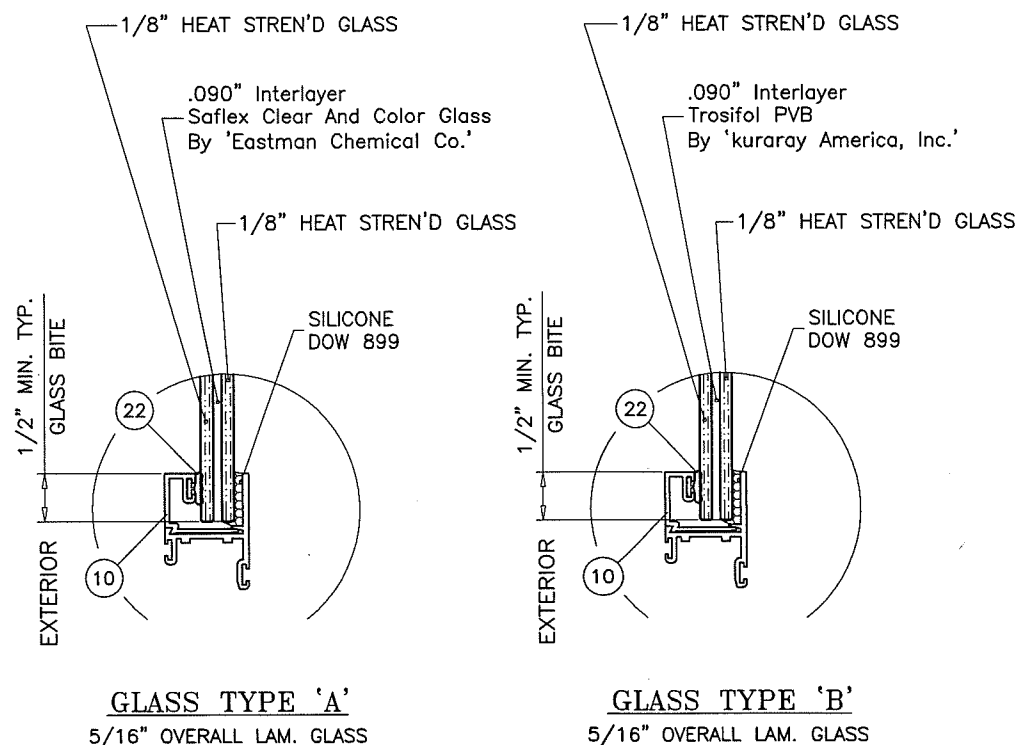

GLASS TYPE 'A'
 5/16" OVERALL LAM. GLASS

GLASS TYPE 'B'
 5/16" OVERALL LAM. GLASS

GLAZING OPTIONS

PRODUCT RENEWED
 as complying with the Florida Building Code
 Acceptance No. 19-0219-08
 Expiration Date June 19, 2024
 By: *Sheng J. Chang*
 Miami Dade Product Control

NOTE:
 GLASS CAPACITIES ON THIS SHEET ARE BASED ON ASTM E1300-09 (3 SEC. GUSTS) AND FLORIDA BUILDING COMMISSION DECLARATORY STATEMENT DCA05-DEC-219

PRODUCT REVISED
 as complying with the Florida Building Code
 Acceptance No. 17-1102-22
 Expiration Date 06/19/2019
 By: *Sifang Zhao*
 Miami Dade Product Control

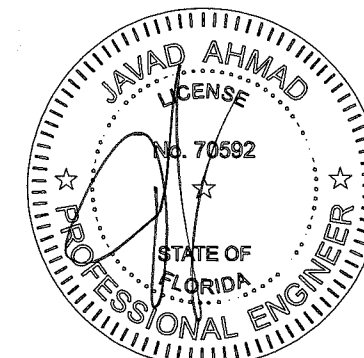

ECO-GUARD SERIES-60 ALUM. HORIZ. ROLLING WDW. (L.M.I.)
ECO WINDOW SYSTEMS, LLC.
 8502 N.W. 80th STREET
 MEDLEY, FL. 33166
 TEL. (305) 885-5299 FAX (305) 885-5902

revisions:	no.	date	description	by
	A	05.23.14	REV. PER PER COMMENTS	
	B	10.19.17	UPDATED TO 2017 FBC	

date:	03-28-14
scale:	1/2" = 1'-0"
dr. by:	TARIQ
chk. by:	

drawing no.	W14-11
sheet	1 of 5

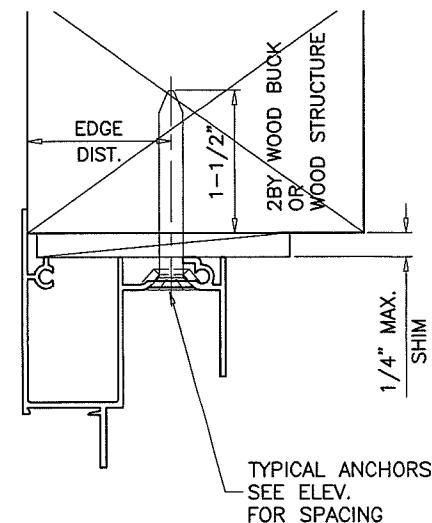
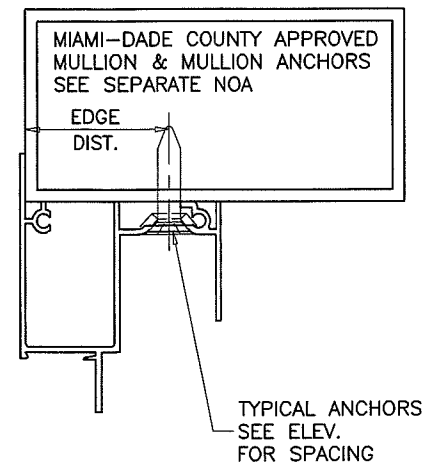
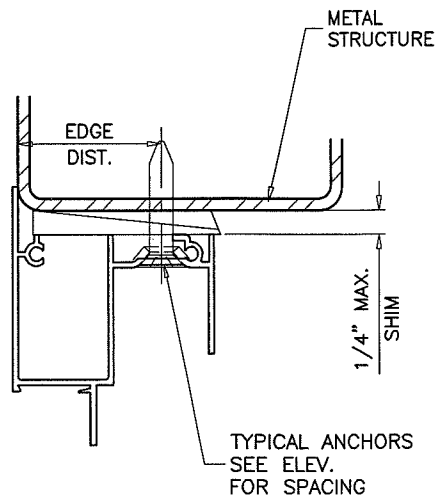
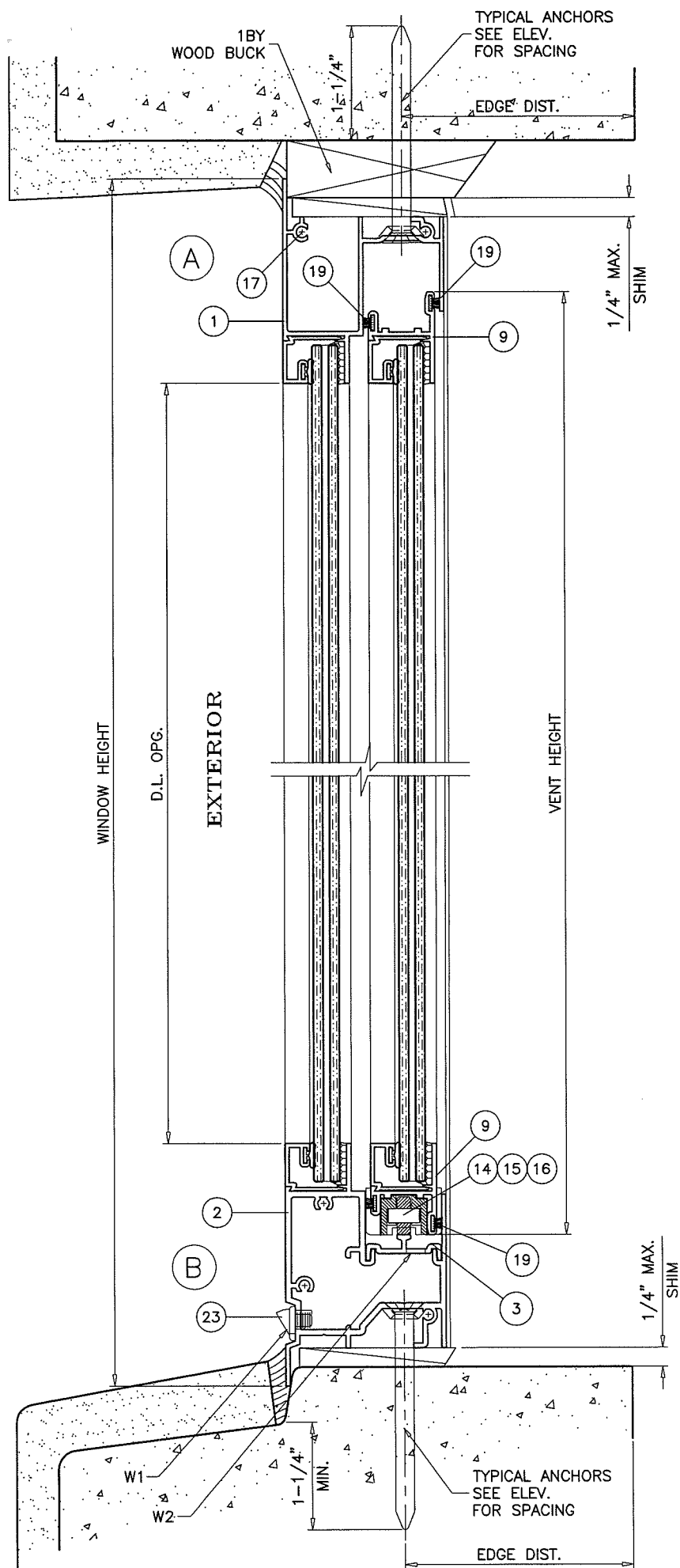

WOOD BUCKS AND METAL STRUCTURE NOT BY ECO WDW. MUST SUSTAIN LOADS IMPOSED BY GLAZING SYSTEM AND TRANSFER THEM TO THE BUILDING STRUCTURE.

WEEPHOLES:

- W1 = 1/4" X 1-5/8" WEEPHOLES WITH BAFFLE AT 4" FROM EACH END AND AT MIDSPAN
- W2 = 1/4" X 1" WEEPHOLES AT 2-1/4" FROM EACH END AND AT MIDSPAN

SEALANT:

ALL JOINTS AND FRAME CONNECTIONS SEALED WITH JOINT SEALER.

TYPICAL ANCHORS: SEE ELEV. FOR SPACING

- 1/4" DIA. TAPCON BY 'ITW' (Fu=125 KSI, Fy=100 KSI)
- 1/4" DIA. ULTRACON BY 'ELCO' (Fu=177 KSI, Fy=155 KSI)
- INTO 2BY WOOD BUCKS OR WOOD STRUCTURES
- 1-1/2" MIN. PENETRATION INTO WOOD (HEAD/SILL/JAMBS)
- THRU 1BY BUCKS INTO CONC. OR BLOCKS
- 1-1/4" MIN. EMBED INTO CONCRETE (HEAD/SILL/JAMBS)
- 1-1/4" MIN. EMBED INTO BLOCKS (JAMBS)
- DIRECTLY INTO CONCRETE OR BLOCKS
- 1-1/4" MIN. EMBED INTO CONCRETE (HEAD/SILL/JAMBS)
- 1-1/4" MIN. EMBED INTO BLOCKS (JAMBS)

#14 SMS OR SELF DRILLING SCREWS (GRADE 2 CRS)
 INTO MIAMI-DADE COUNTY APPROVED MULLIONS OR
 INTO METAL STRUCTURES (HEAD/SILL/JAMBS)
 (3) THREADS MIN. PENETRATION BEYOND SUBSTRATE
 ALUMINUM: 1/8" THK. MIN. (6063-T5 MIN.)
 STEEL: 1/8" THK. MIN. (Fy = 36 KSI MIN.)
 (STEEL IN CONTACT WITH ALUMINUM TO BE PLATED OR PAINTED)

TYPICAL EDGE DISTANCE

- INTO CONCRETE AND MASONRY = 2-1/2" MIN.
- INTO WOOD STRUCTURE = 1" MIN.
- INTO METAL STRUCTURE = 3/4" MIN.

WOOD AT HEAD, SILL OR JAMBS SG = 0.55 MIN.
 CONCRETE AT HEAD, SILL OR JAMBS f'c = 3000 PSI MIN.
 C-90 HOLLOW/FILLED BLOCK AT JAMBS f'm = 2000 PSI MIN.

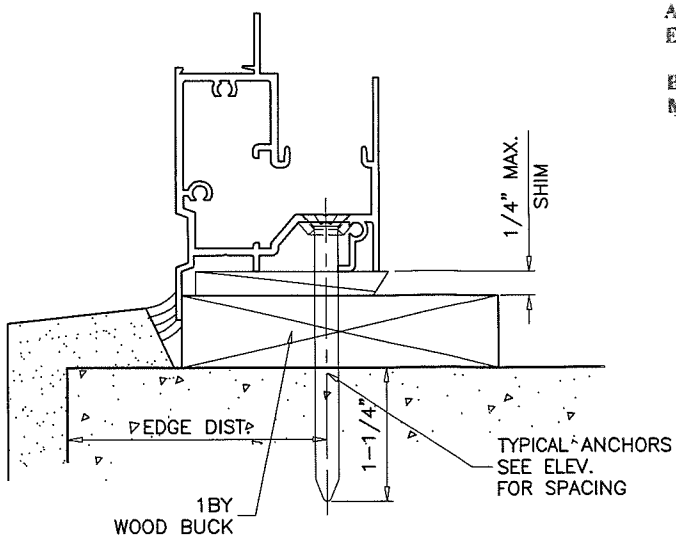

PRODUCT RENEWED
 as complying with the Florida Building Code
 Acceptance No. 19-0219-08
 Expiration Date 6/19/2024
 By *Kamal L. Chaudhry*
 Miami Dade Product Control

PRODUCT REVISED
 as complying with the Florida Building Code
 Acceptance No. 17-1102-22
 Expiration Date 06/19/2024
 By *Sifang Zhao*
 Miami Dade Product Control

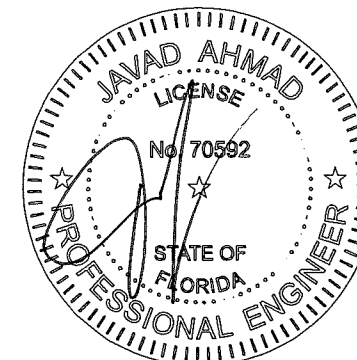

af c
AL-FAROOQ CORPORATION
 ENGINEERS & PRODUCT DEVELOPMENT
 9360 SUNSET DRIVE, SUITE 220
 MIAMI, FLORIDA 33173
 TEL. (305) 264-8100 FAX. (305) 262-6978
 COMP-ANL\W14-11ECO

ECO-GUARD SERIES-60 ALUM. HORIZ. ROLLING WDW. (L.M.I.)
ECO WINDOW SYSTEMS, LLC.
 8502 N.W. 80th STREET
 MEDLEY, FL. 33166
 TEL. (305) 885-5299 FAX (305) 885-5902

revisions:	no.	date	description
	A	05.23.14	REV. PER RER COMMENTS
	B	10.19.17	UPDATED TO 2017 FBC

date:	03-28-14
scale:	1/2" = 1"
dr. by:	TARIQ
chk. by:	

drawing no.	W14-11
sheet	2 of 5

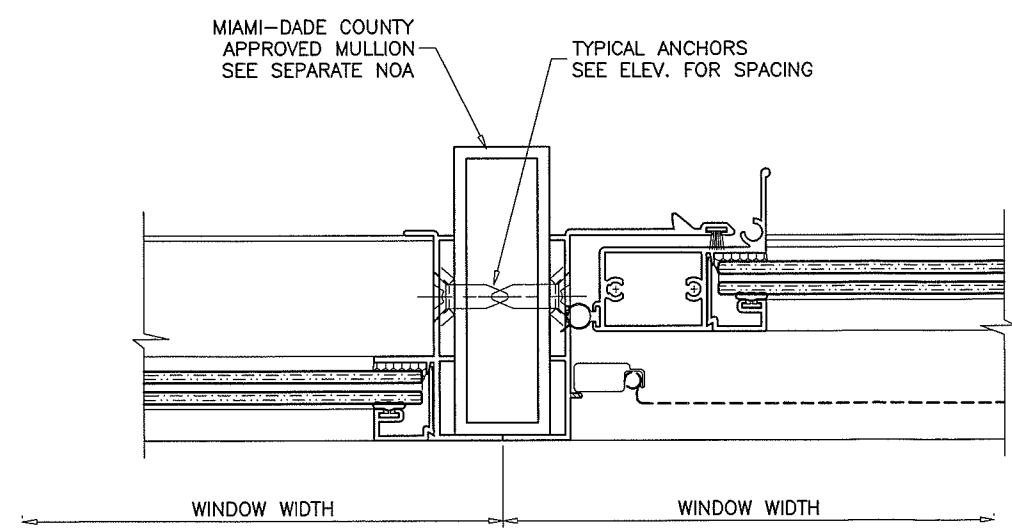
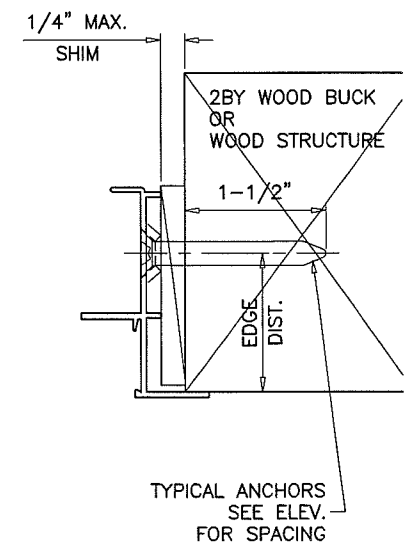
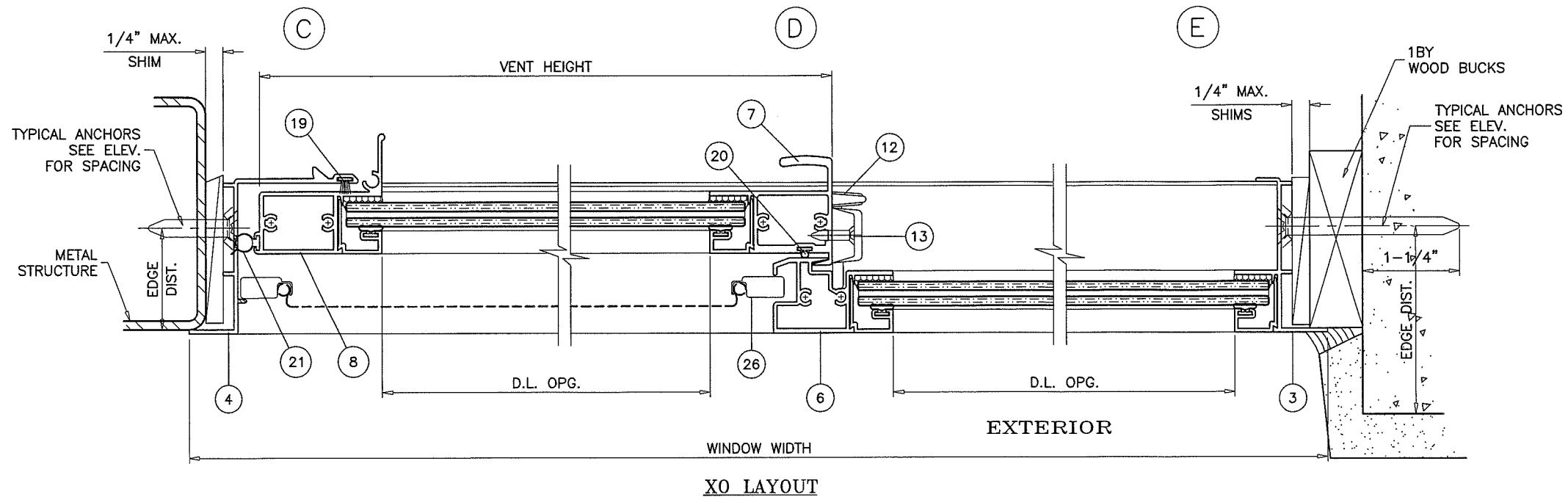

PRODUCT REVISED
 as complying with the Florida
 Building Code
 Acceptance No. 17-1102.22
 Expiration Date 06/19/2019
 By Sifeng Zhao
 Miami Dade Product Control

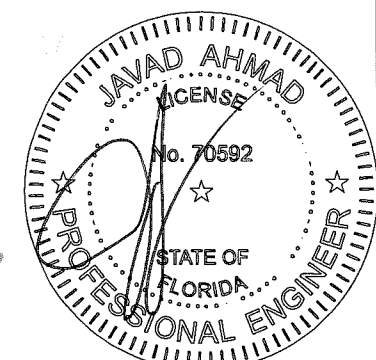

PRODUCT RENEWED
 as complying with the Florida
 Building Code
 Acceptance No. 19-0219.08
 Expiration Date 6/19/2024
 By Leung J. Chong
 Miami Dade Product Control

afc
AL-FAROOQ CORPORATION
 ENGINEERS & PRODUCT DEVELOPMENT
 9360 SUNSET DRIVE, SUITE 220
 MIAMI, FLORIDA 33173 (C.A.N. 3538)
 TEL. (305) 264-8100 FAX. (305) 262-6978
 COMP-ANL\W14-11ECO

ECO-GUARD SERIES-60 ALUM. HORIZ. ROLLING WDW. (L.M.I.)
ECO WINDOW SYSTEMS, LLC.
 8502 N.W. 80th STREET
 MEDLEY, FL. 33166
 TEL. (305) 885-5299 FAX (305) 885-5902

revisions:	no.	date	description
	A	05.23.14	REV. PER RER COMMENTS
	B	10.19.17	UPDATED TO 2017 FBC

date:	03-28-14
scale:	1/2" = 1"
dr. by:	TARIQ
chk. by:	

drawing no.
W14-11
 sheet 3 of 5

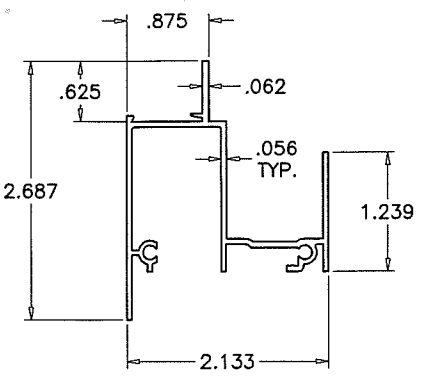

① FRAME HEAD

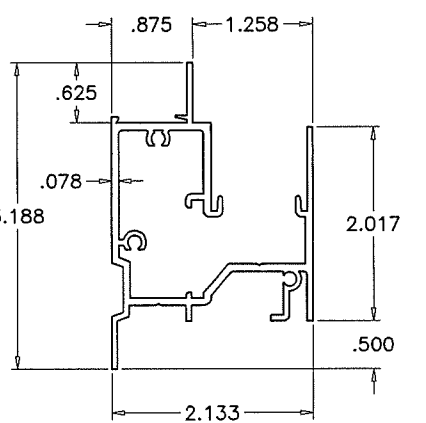

② FRAME SILL

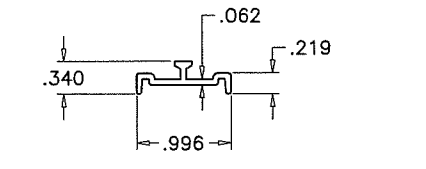

③ SILL TRACK

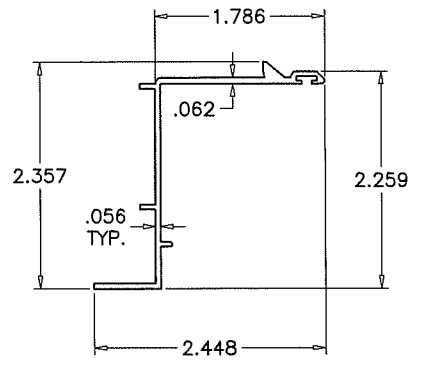

④ MOV. FRAME JAMB

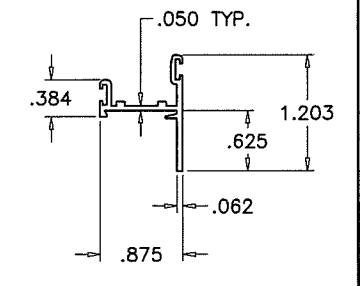

⑨ VENT TOP/BOTTOM RAIL

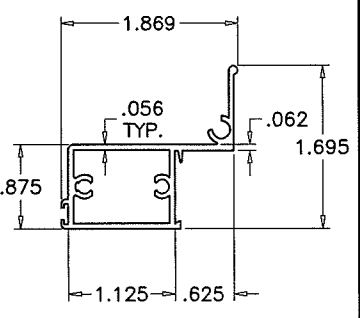

⑧ JAMB STILE

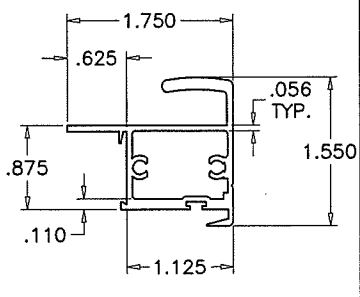

⑦ MEETING RAIL

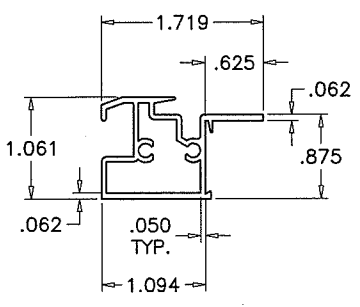

⑥ FIXED MTG. RAIL

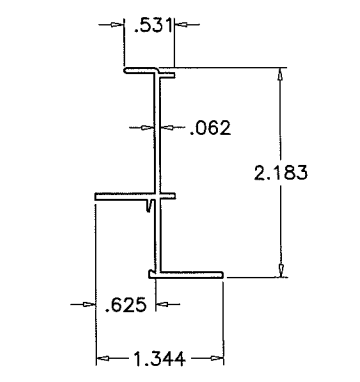

⑤ FIXED FRAME JAMB

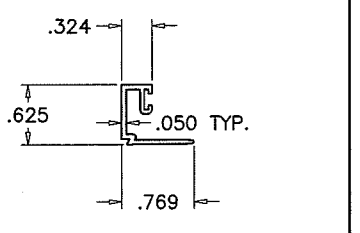

⑩ GLAZING BEAD

ITEM	PART #	QUANTITY	DESCRIPTION	MATERIAL	MANF./SUPPLIER/REMARKS
1	E53	1	FRAME HEAD	6063-T6	-
2	E61	1	FRAME SILL	6063-T6	-
3	E62	1	SILL TRACK INSERT	6063-T6	-
4	E52	AS REQD.	MOV. FRAME JAMB	6063-T6	-
5	E51	AS REQD.	FIXED FRAME JAMB	6063-T6	-
6	E54	1/ VENT	FIXED MTG. RAIL	6063-T6	-
7	E66	1/ VENT	VENT MEETING STILE	6063-T6	-
8	E56	1/ VENT	VENT JAMB STILE	6063-T6	-
9	E57	2/ VENT	TOP AND BOTTOM RAIL	6063-T6	-
10	E58	AS REQD.	GLAZING BEAD	6063-T6	-
12	SL203P	2/ VENT	SWEEP LATCH, AT 9-1/2" FROM TOP & BOTTOM	-	SULLIVAN & ASSOC.
13	#8 X 5/8"	2/ LATCH	LATCH INST. SCREW	ST. STEEL	FH SMS
14	E63	2/ VENT	ROLLER HOUSING & GUIDE	CELCON	-
15	E64	2/ VENT	ROLLER	BRASS	-
16	E65	2/ VENT	ROLLER PIN	ST. STEEL	-
17	#8 X 1"	AS REQD.	FRAME/VENT ASSEMBLY SCREWS	CRS	P.H. SMS
18	#8 X 3"	2/ VENT	FIX. RAIL SILL SCREWS (SILL END)	CRS	P.H. SMS
19	W23181	AS REQD.	PILE WITH INTEGRAL FIN W'STRIPPING	-	ULTRAFAB
21	E207	AS REQD.	BULB SEAL	SANTOPRENE	ULTRAFAB, DUROMETER 65±5
22	E203	AS REQD.	GLAZING BEAD BULB	SANTOPRENE	ULTRAFAB, DUROMETER 65±5
23	WA2L	2/ WDW.	WEEP VALVE	-	PREFERRED ENG. PRODUCTS
24	-	1/ VENT	5/16" BOX SCREEN	-	OPTIONAL

PRODUCT REVISED
as complying with the Florida
Building Code
Acceptance No 17-1102-22
Expiration Date 06/19/2019
By Sifang Zhao
Miami Dade Product Control

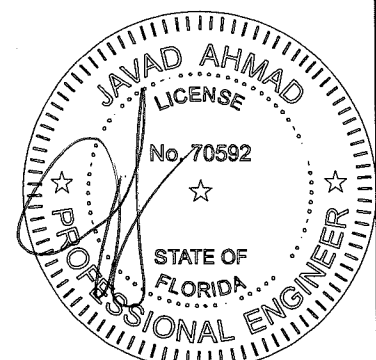

PRODUCT RENEWED
as complying with the Florida
Building Code
Acceptance No 19-0219-08
Expiration Date 02/19/2024
By Ishtiaq J. Chaudhry
Miami Dade Product Control

revisions:	no	date	description
	A	05.23.14	NO CHANGE THIS SHEET
	B	10.19.17	UPDATED TO 2017 FBC

date: 03-28-14
scale: 1/2" = 1"
dr. by: TARIQ
chk. by:

drawing no.
W14-11
sheet 4 of 5

af c
AL-FAROOQ CORPORATION
ENGINEERS & PRODUCT DEVELOPMENT
9360 SUNSET DRIVE, SUITE 220 (C.A.N. 3538)
MIAMI, FLORIDA 33173 FAX. (305) 262-6978
TEL. (305) 264-8100 COMP-ANL\W14-11ECO

ECO-GUARD SERIES-60 ALUM HORIZ. ROLLING WDW. (L.M.I.)
ECO WINDOW SYSTEMS, LLC.
8502 N.W. 80th STREET
MEDLEY, FL. 33166
TEL. (305) 885-5299 FAX (305) 885-5902

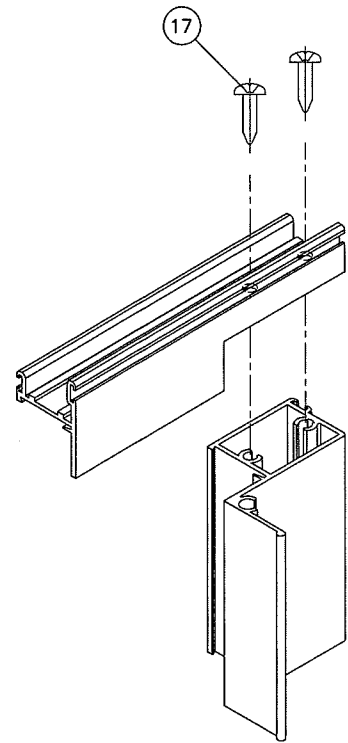

VENT TOP/BOTTOM CORNERS

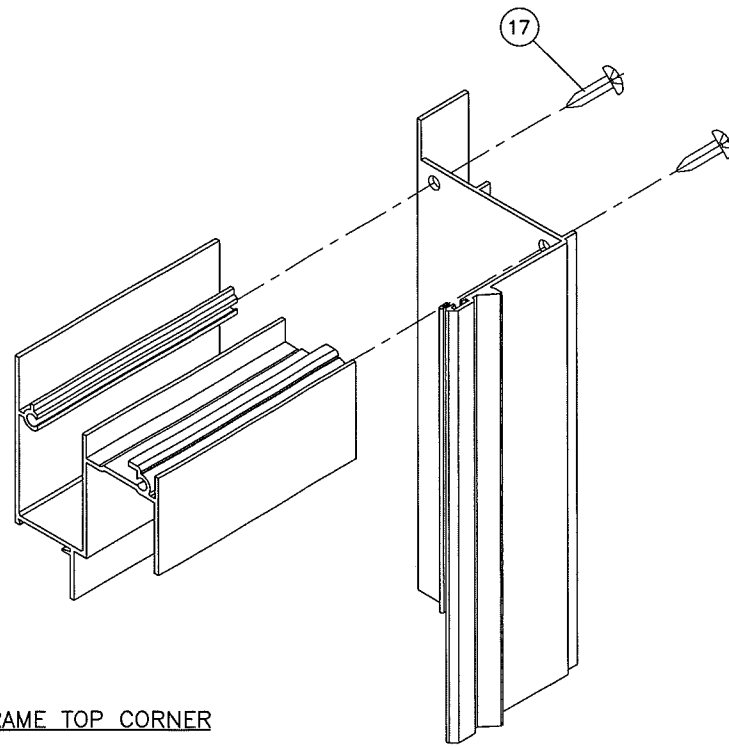

FRAME TOP CORNER

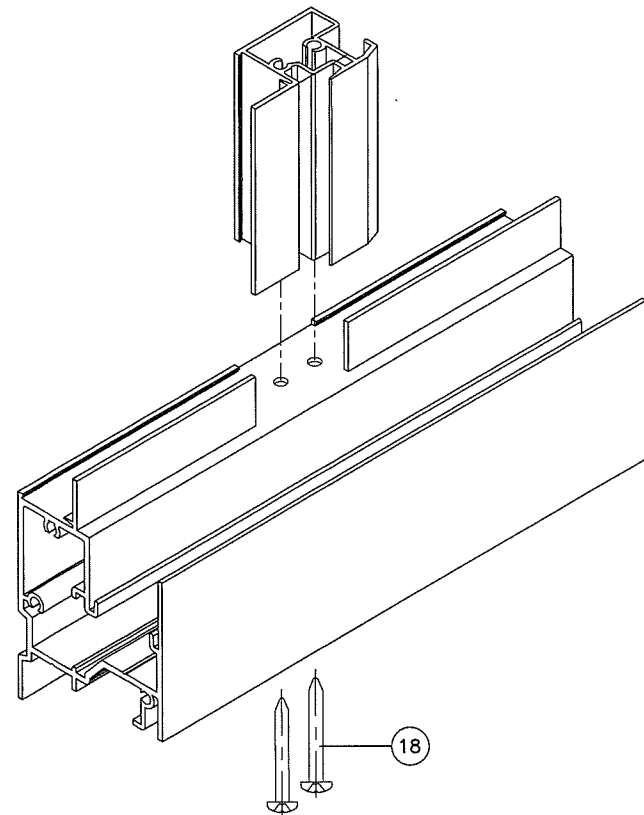

FIXED MTG. RAIL CORNER

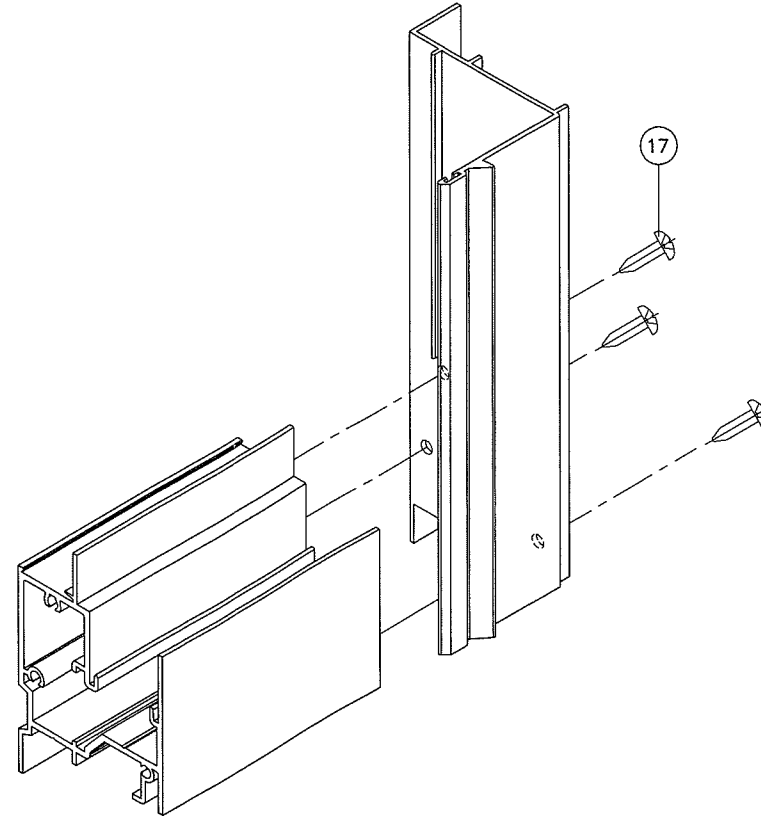

FRAME BOTTOM CORNER

PRODUCT RENEWED
 as complying with the Florida
 Building Code
 Acceptance No 19-0219.08
 Expiration Date 6/19/2024
 By Shay I. Chanda
 Miami Dade Product Control

PRODUCT REVISED
 as complying with the Florida
 Building Code
 Acceptance No 17-1102.22
 Expiration Date 06/19/2019
 By Sifang zhan
 Miami Dade Product Control

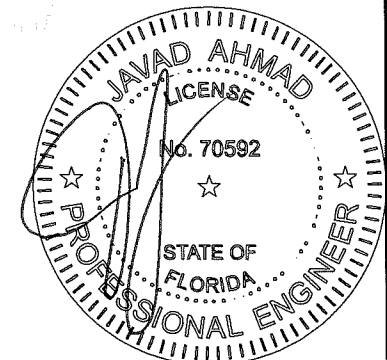

AL-FAROOQ CORPORATION
 ENGINEERS & PRODUCT DEVELOPMENT
 9360 SUNSET DRIVE, SUITE 220
 MIAMI, FLORIDA 33173 (C.A.N. 3538)
 TEL. (305) 264-8100 FAX. (305) 262-6978

ECO-GUARD SERIES-60 ALUM. HORIZ. ROLLING WDW. (L.M.I.)
ECO WINDOW SYSTEMS, LLC.
 8502 N.W. 80th STREET
 MEDLEY, FL. 33166
 TEL. (305) 885-5299 FAX (305) 885-5902

revisions:	no	date	description
	A	05.23.14	NO CHANGE THIS SHEET
	B	10.19.17	UPDATED TO 2017 FBC

date:	03-28-14
scale:	1/2" = 1"
dr. by:	TARIQ
chk. by:	

drawing no.
W14-11
 sheet 5 of 5

COMP-ANL\W14-11ECO