



DEPARTMENT OF REGULATORY AND ECONOMIC RESOURCES (RER)
NOTICE OF ACCEPTANCE (NOA)

PGT Industries, Inc.
1070 Technology Drive
North Venice, FL 34275

SCOPE:

This NOA is being issued under the applicable rules and regulations governing the use of construction materials. The documentation submitted has been reviewed and accepted by Miami-Dade County RER - Product Control Section to be used in Miami Dade County and other areas where allowed by the Authority Having Jurisdiction (AHJ).

This NOA shall not be valid after the expiration date stated below. The Miami-Dade County Product Control Section (In Miami-Dade County) and/or the AHJ (in areas other than Miami-Dade County) reserve the right to have this product or material tested for quality assurance purposes. If this product or material fails to perform in the accepted manner, the manufacturer will incur the expense of such testing and the AHJ may immediately revoke, modify, or suspend the use of such product or material within their jurisdiction. RER reserves the right to revoke this acceptance if it is determined by Miami-Dade County Product Control Section that this product or material fails to meet the requirements of the applicable building code.

This product is approved as described herein and has been designed to comply with the Florida Building Code, including the High Velocity Hurricane Zone.

DESCRIPTION: Series "HR7710A" Aluminum Horizontal Roller Window – L.M.I.

APPROVAL DOCUMENT: Drawing No. 7710NOA-1, titled "Aluminum Horiz. Roller Install (LM)", sheets 1 through 19 of 19, dated 06/30/18, with revision A dated 03/11/20, prepared by manufacturer, signed and sealed by Anthony Lynn Miller, P.E., bearing the Miami-Dade County Product Control Revision stamp with the Notice of Acceptance number and expiration date by the Miami-Dade County Product Control Section.

MISSILE IMPACT RATING: Large and Small Missile Impact Resistant

LABELING: Each unit shall bear a permanent label with the manufacturer's name or logo, city, state, model/series, and following statement: "Miami-Dade County Product Control Approved", unless otherwise noted herein.

RENEWAL of this NOA shall be considered after a renewal application has been filed and there has been no change in the applicable building code negatively affecting the performance of this product.

TERMINATION of this NOA will occur after the expiration date or if there has been a revision or change in the materials, use, and/or manufacture of the product or process. Misuse of this NOA as an endorsement of any product, for sales, advertising or any other purposes shall automatically terminate this NOA. Failure to comply with any section of this NOA shall be cause for termination and removal of NOA.

ADVERTISEMENT: The NOA number preceded by the words Miami-Dade County, Florida, and followed by the expiration date may be displayed in advertising literature. If any portion of the NOA is displayed, then it shall be done in its entirety.

INSPECTION: A copy of this entire NOA shall be provided to the user by the manufacturer or its distributors and shall be available for inspection at the job site at the request of the Building Official.

This NOA **revises NOA No. 18-0627.01** and consists of this page 1 and evidence pages E-1, E-2, E-3 and E-4, as well as approval document mentioned above.

The submitted documentation was reviewed by **Manuel Perez, P.E.**

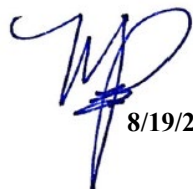

8/19/20

NOA No. 20-0406.04
Expiration Date: August 23, 2023
Approval Date: August 27, 2020
Page 1

NOTICE OF ACCEPTANCE: EVIDENCE SUBMITTED

1. EVIDENCE SUBMITTED UNDER PREVIOUS NOA's

A. DRAWINGS

1. Manufacturer's die drawings and sections.
(Submitted under NOA No. 18-0627.01)
2. Drawing No. **7710NOA-1**, titled "Aluminum Horiz. Roller Install (LM), sheets 1 through 19 of 19, dated 06/30/18, prepared by manufacturer, signed and sealed by Anthony Lynn Miller, P.E.
(Submitted under NOA No. 18-0627.01)

B. TESTS

1. Test reports on: 1) Air Infiltration Test, per FBC, TAS 202-94
2) Uniform Static Air Pressure Test, Loading per FBC, TAS 202-94
3) Water Resistance Test, per FBC, TAS 202-94
4) Large Missile Impact Test per FBC, TAS 201-94
5) Cyclic Wind Pressure Loading per FBC, TAS 203-94
6) Forced Entry Test, per FBC 2411.3.2.1, and TAS 202-94
along with marked-up drawings and installation diagram of an aluminum horizontal sliding window, prepared by Fenestration Testing Laboratory, Inc., Test Report No. **FTL-18-7891**, dated 06/06/18, signed and sealed by Idalmis Ortega, P.E.
(Submitted under NOA No. 18-0627.01)
2. Test reports on: 1) Air Infiltration Test, per FBC, TAS 202-94
2) Uniform Static Air Pressure Test, Loading per FBC, TAS 202-94
3) Water Resistance Test, per FBC, TAS 202-94
4) Large Missile Impact Test per FBC, TAS 201-94
5) Cyclic Wind Pressure Loading per FBC, TAS 203-94
6) Forced Entry Test, per FBC 2411.3.2.1, and TAS 202-94
along with marked-up drawings and installation diagram of an aluminum horizontal sliding window, prepared by Fenestration Testing Laboratory, Inc., Test Report No. **FTL-18-7891.01**, dated 07/03/18, signed and sealed by Idalmis Ortega, P.E.
(Submitted under NOA No. 18-0627.01)

C. CALCULATIONS

1. Anchor verification calculations and structural analysis, complying with **FBC 6th Edition (2017)**, dated 06/18/18 and updated on 07/25/18, prepared by manufacturer, signed and sealed by Anthony Lynn Miller, P.E.
(Submitted under NOA No. 18-0627.01)
2. Glazing complies with **ASTM E1300-09**



Manuel Perez, P.E.
Product Control Examiner
NOA No. 20-0406.04
Expiration Date: August 23, 2023
Approval Date: August 27, 2020

PGT Industries, Inc.

NOTICE OF ACCEPTANCE: EVIDENCE SUBMITTED

1. EVIDENCE SUBMITTED UNDER PREVIOUS NOA's (CONTINUED)

D. QUALITY ASSURANCE

1. Miami-Dade Department of Regulatory and Economic Resources (RER).

E. MATERIAL CERTIFICATIONS

1. Notice of Acceptance No. **17-1114.14** issued to **Kuraray America, Inc.** for their "Trosifol® Ultraclear, Clear and Color PVB Glass Interlayers" dated 01/18/18, expiring on 07/08/19.
2. Notice of Acceptance No. **17-0808.02** issued to **Kuraray America, Inc.** for their "SentryGlas® (Clear and White) Glass Interlayers" dated 12/28/17, expiring on 07/04/23.

F. STATEMENTS

1. Statement letter of conformance to **FBC 6th Edition (2017)**, dated July 25, 2018, issued by manufacturer, signed and sealed by Anthony Lynn Miller, P.E.
(Submitted under NOA No. 18-0627.01)
2. Statement letter of no financial interest, dated July 25, 2018, issued by manufacturer, signed and sealed by Anthony Lynn Miller, P.E.
(Submitted under NOA No. 18-0627.01)
3. Proposal No. **18-0289** issued by the Product Control Section, dated 02/20/18, signed by Manuel Perez, P.E.
(Submitted under NOA No. 18-0627.01)

G. OTHERS

1. None.

Manuel Perez, P.E.
Product Control Examiner
NOA No. 20-0406.04
Expiration Date: August 23, 2023
Approval Date: August 27, 2020

NOTICE OF ACCEPTANCE: EVIDENCE SUBMITTED

2. NEW EVIDENCE SUBMITTED

A. DRAWINGS

1. Drawing No. **7710NOA-1**, titled “Aluminum Horiz. Roller Install (LM), sheets 1 through 19 of 19, dated 06/30/18, with revision A dated 03/11/20, prepared by manufacturer, signed and sealed by Anthony Lynn Miller, P.E.

B. TESTS

1. Test reports on: 1) Air Infiltration Test, per FBC, TAS 202-94
2) Uniform Static Air Pressure Test, Loading per FBC, TAS 202-94
3) Water Resistance Test, per FBC, TAS 202-94
4) Large Missile Impact Test per FBC, TAS 201-94
5) Cyclic Wind Pressure Loading per FBC, TAS 203-94
6) Forced Entry Test, per ASTM F588 and TAS 202-94

along with marked-up drawings and installation diagram of all PGT Industries, Inc. representative units listed below and tested to qualify **Dowsil 791** and **Dowsil 983** silicones, prepared by Fenestration Testing Laboratory, Inc., Test Reports No.: **FTL-7897**, PGT PW5520 PVC Fixed Window (unit 6 in proposal), dated 09/03/14 **FTL-20-2107.1**, PGT SGD780 Aluminum Sliding Glass Door (unit 7 in proposal) **FTL-20-2107.2**, PGT CA740 Alum. Outswing Casement Window (unit 8 in proposal) **FTL-20-2107.3**, PGT PW7620A Aluminum Fixed Window (unit 9 in proposal) and **FTL-20-2107.4**, PGT PW7620A Aluminum Fixed Window (unit 10 in proposal) dated 07/13/20, all signed and sealed by Idalmis Ortega, P.E

C. CALCULATIONS

1. Anchor verification calculations and structural analysis, complying with **FBC 6th Edition (2017)**, prepared by manufacturer, dated 06/18/18, revised on 07/25/18 and updated to the **FBC 7th Edition (2020)** on 04/02/20, signed and sealed by Anthony Lynn Miller, P.E.

D. QUALITY ASSURANCE

1. Miami-Dade Department of Regulatory and Economic Resources (RER)

E. MATERIAL CERTIFICATIONS

1. Notice of Acceptance No. **19-0305.02** issued to **Kuraray America, Inc.** for their “**Trosifol® Ultraclear, Clear and Color PVB Glass Interlayers**” dated 05/09/19, expiring on 07/08/24.
2. Notice of Acceptance No. **18-0725.11** issued to **Kuraray America, Inc.** for their “**Kuraray SentryGlas® Xtra™ (SGX™) Clear Glass Interlayer**” dated 05/23/19, expiring on 05/23/24.

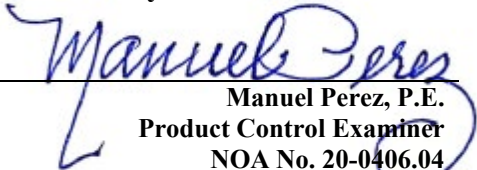
Manuel Perez, P.E.
Product Control Examiner
NOA No. 20-0406.04
Expiration Date: August 23, 2023
Approval Date: August 27, 2020

PGT Industries, Inc.

NOTICE OF ACCEPTANCE: EVIDENCE SUBMITTED

2. NEW EVIDENCE SUBMITTED (CONTINUED)

F. STATEMENTS

1. Statement letter of conformance, complying with **FBC 6th Edition (2017)** and the **FBC 7th Edition (2020)**, dated March 10, 2020, issued by manufacturer, signed and sealed by Anthony Lynn Miller, P.E.
2. Statement letter of no financial interest, dated March 10, 2020, issued by manufacturer, signed and sealed by Anthony Lynn Miller, P.E.
3. Proposal No. **19-1155 TP** issued by the Product Control Section, dated January 10, 2020, signed by Ishaq Chanda, P.E.

G. OTHERS

1. Notice of Acceptance No. **18-0627.01**, issued to PGT Industries, Inc. for their Series "HR7710A" Aluminum Horizontal Roller Window - L.M.I. approved on 08/23/18 and expiring on 08/23/23.

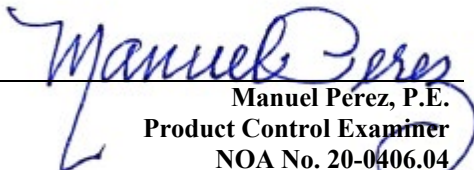

Manuel Pérez, P.E.

Product Control Examiner

NOA No. 20-0406.04

Expiration Date: August 23, 2023

Approval Date: August 27, 2020

SERIES HR7710A IMPACT RESISTANT HORIZONTAL ROLLER WINDOW

- 1) THIS PRODUCT HAS BEEN DESIGNED & TESTED TO COMPLY WITH THE REQUIREMENTS OF THE FLORIDA BUILDING CODE, INCLUDING THE HIGH VELOCITY HURRICANE ZONE (HVHZ).
- 2) SHUTTERS ARE NOT REQUIRED WHEN USED IN WIND-BORNE DEBRIS REGIONS. FOR INSULATED GLASS INSTALLATIONS ABOVE 30' IN THE HVHZ, THE OUTBOARD LITE (CAP) MUST BE TEMPERED.
- 3) FOR MASONRY APPLICATIONS IN MIAMI-DADE COUNTY, USE ONLY MIAMI-DADE COUNTY APPROVED MASONRY ANCHORS. MATERIALS USED FOR ANCHOR EVALUATIONS WERE SOUTHERN PINE, ASTM C90 CONCRETE MASONRY UNITS AND CONCRETE WITH MIN. KSI PER ANCHOR TYPE.
- 4) ALL WOOD BUCKS LESS THAN 1-1/2" THICK ARE TO BE CONSIDERED 1X INSTALLATIONS. 1X WOOD BUCKS ARE OPTIONAL IF UNIT IS INSTALLED DIRECTLY TO SUBSTRATE. WOOD BUCKS DEPICTED AS 2X ARE 1-1/2" THICK OR GREATER. 1X AND 2X BUCKS (WHEN USED) SHALL BE DESIGNED AND SECURED TO PROPERLY TRANSFER LOADS TO THE STRUCTURE. WOOD BUCK DESIGN AND INSTALLATION IS THE RESPONSIBILITY OF THE ENGINEER, (EOR) OR ARCHITECT OF RECORD, (AOR).
- 5) ANCHOR EMBEDMENT TO BASE MATERIAL SHALL BE BEYOND WALL DRESSING OR STUCCO. USE ANCHORS OF SUFFICIENT LENGTH TO ACHIEVE REQUIRED MIN. EMBEDMENT. SILL ANCHORS MUST BE SEALED. OVERALL SEALING & FLASHING STRATEGY FOR WATER RESISTANCE OF INSTALLATION SHALL BE DONE BY OTHERS AND IS BEYOND THE SCOPE OF THESE INSTRUCTIONS.
- 6) 1/4" MAX. SHIMS ARE REQUIRED AT EACH ANCHOR LOCATION WHERE THE PRODUCT IS NOT FLUSH TO THE SUBSTRATE. USE SHIMS CAPABLE OF TRANSFERRING APPLIED LOADS.
- 7) DESIGN PRESSURES:
 - A. NEGATIVE DESIGN LOADS BASED ON STRUCTURAL & CYCLE TESTING AND GLASS PER ASTM E1300.
 - B. POSITIVE DESIGN LOADS BASED ON WATER TEST PRESSURE, STRUCTURAL & CYCLE TESTING AND GLASS PER ASTM E1300.
 - C. DESIGN LOADS ARE BASED ON ALLOWABLE STRESS DESIGN, ASD.
- 8) THE ANCHORAGE METHODS SHOWN HAVE BEEN DESIGNED TO RESIST THE WINDLOADS CORRESPONDING TO THE REQUIRED DESIGN PRESSURE. THE 33-1/3% STRESS INCREASE HAS NOT BEEN USED IN THE DESIGN OF THIS PRODUCT. THE 1.6 LOAD DURATION FACTOR WAS USED FOR THE EVALUATION OF ANCHORS INTO WOOD. ANCHORS THAT COME INTO CONTACT WITH OTHER DISSIMILAR MATERIALS SHALL MEET THE REQUIREMENTS OF THE FLORIDA BUILDING CODE FOR CORROSION RESISTANCE.
- 9) METAL SUBSTRATE TO MEET MIN. STRENGTH AND THICKNESS REQUIREMENTS PER CURRENT FLORIDA BUILDING CODE AND TO BE REVIEWED BY THE AUTHORITY HAVING JURISDICTION.
- 10) REFERENCES: TEST REPORTS FTL 18-7891 & 18-7891.01; ELCO ULTRACON NOA; DEWALT/ELCO CRETEFLEX NOA; DEWALT ULTRACON+ NOA; NATIONAL DESIGN SPECIFICATION FOR WOOD CONSTRUCTION, ANSI/AF&PA NDS & ALUMINUM DESIGN MANUAL
- 11) APPLICABLE EGRESS REQUIREMENTS TO BE REVIEWED BY BUILDING OFFICIAL.

TABLE 1:

Glass Type	Description (Listed from Exterior to Interior)	DP Table #		Anchor Table #			
		XO / OX		XOX		XOX	
		STD	HD	STD	HD	STD	
1	1/8" AN, .090" PVB, 1/8" AN	2	-	7	12	-	15
2	1/8" HS, .090" PVB, 1/8" HS	3	-	8	12	-	16
3	3/16" AN, .090" PVB, 3/16" AN	3	-	8	12	-	16
4	13/16" LIG: 1/8" AN CAP, AIRSPACE, 1/8" AN, .090" PVB, 1/8" AN	4	-	7	12	-	15
5	13/16" LIG: 1/8" TP CAP, AIRSPACE, 1/8" AN, .090" PVB, 1/8" AN	3	-	7	12	-	15
6	13/16" LIG: 3/16" AN CAP, AIRSPACE, 1/8" AN, .090" PVB, 1/8" AN	3	-	9	12	-	16
7	13/16" LIG: 3/16" TP CAP, AIRSPACE, 1/8" AN, .090" PVB, 1/8" AN	3	-	9	12	-	16
8	3/16" AN, .090" SG, 3/16" AN	5	6	10	13	14	17
9	3/16" HS, .090" SG, 3/16" HS	5	6	11	13	14	18
10	13/16" LIG: 1/8" AN CAP, AIRSPACE, 3/16" AN, .090" SG, 3/16" AN	5	6	10	13	14	17
11	13/16" LIG: 1/8" TP CAP, AIRSPACE, 3/16" AN, .090" SG, 3/16" AN	5	6	10	13	14	17
12	13/16" LIG: 1/8" AN CAP, AIRSPACE, 1/8" HS, .090" SG, 1/8" HS	5	6	11	13	14	18
13	13/16" LIG: 1/8" TP CAP, AIRSPACE, 1/8" HS, .090" SG, 1/8" HS	5	6	11	13	14	18
14	13/16" LIG: 3/16" AN CAP, AIRSPACE, 1/8" HS, .090" SG, 1/8" HS	5	6	11	13	14	18
15	13/16" LIG: 3/16" TP CAP, AIRSPACE, 1/8" HS, .090" SG, 1/8" HS	5	6	11	13	14	18

SG= KURARAY SENTRYGLAS® INTERLAYER BY KURARAY AMERICA, INC.
 PVB = KURARAY TROSIFOL® PVB INTERLAYER BY KURARAY AMERICA, INC.
 AN = ANNEALED
 HS = HEAT-STRENGTHENED
 TP = TEMPERED

DESIGN PRESSURE RATING VARIES PER GLASS TYPE, SEE TABLES 2-11	IMPACT RATING LARGE & SMALL MISSILE IMPACT RESISTANT
---	--

USER INSTRUCTIONS:

- 1) DETERMINE THE SITE SPECIFIC, WINDOW OPENING'S DESIGN PRESSURE REQUIREMENT FROM ASCE 7.
 - 2) KNOWING YOUR GLAZING OPTION (TABLE 1), WINDOW CONFIGURATION AND SIZE, DETERMINE YOUR WINDOW'S DESIGN PRESSURE FROM TABLES 2-11. IT MUST EQUAL OR EXCEED THE DESIGN PRESSURE REQUIREMENT FOR THE WINDOW OPENING OBTAINED IN STEP 1.
 - 3) DETERMINE THE ANCHOR QUANTITY FROM TABLES 12-18.
 - 4) INSTALL AS PER SHEET 15 FOR FLANGE INSTALLATION, SHEET 16 FOR EQUAL LEG INSTALLATION OR SHEET 17 FOR INTEGRAL FIN INSTALLATION.
- NOTE: DESIGN PRESSURE RATING DETERMINATION IS THE SAME PROCESS FOR ALL FRAME TYPES (FLANGE, INTEGRAL FIN OR EQUAL LEG/BOX).

WEEPHOLE NOTES:
 1) 1-5/8" X .300" WITH PLASTIC BAFFLE.
 2) 1 WEEPHOLE LOCATED AT 4" FROM EACH END.
 3) 1 WEEPHOLE LOCATED UNDER EACH MEETING RAIL.

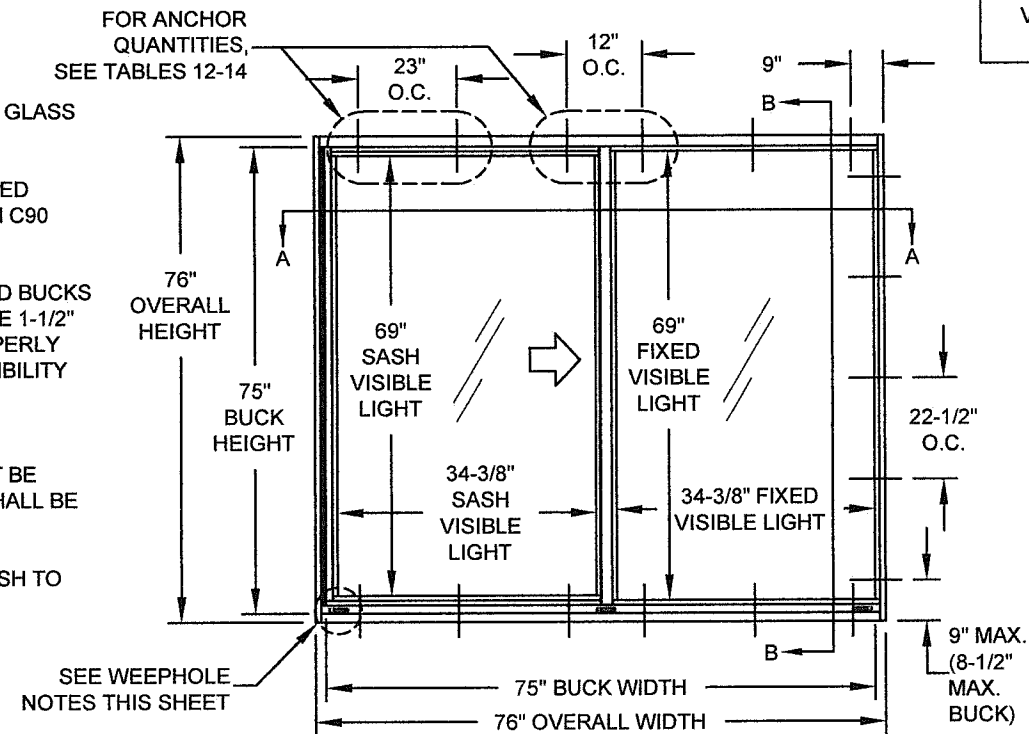

TYP. FLANGE XO ELEVATION (OX SIM.)
MAX. DIMENSIONS ALLOWED SHOWN

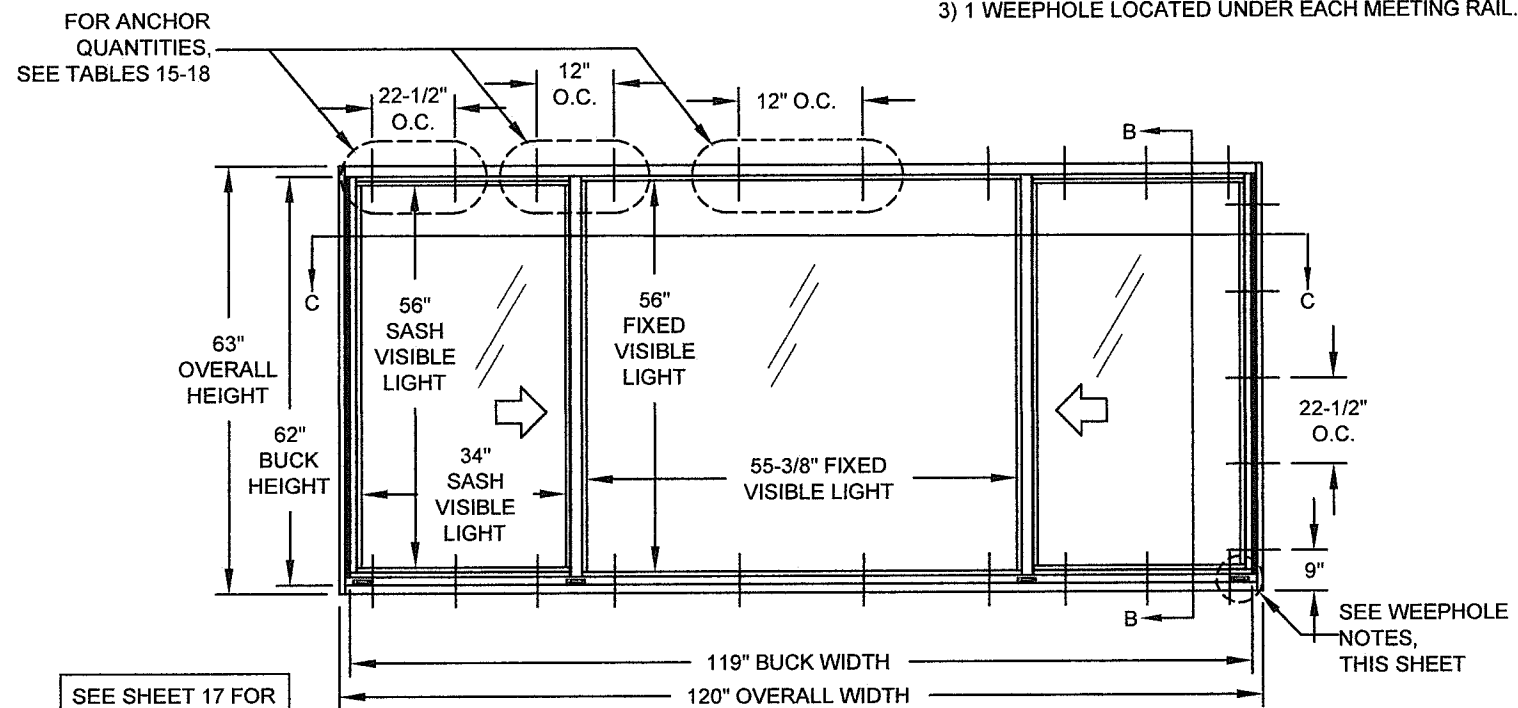

TYP. FLANGE XOX ELEVATION
MAX. DIMENSIONS ALLOWED SHOWN

- CODES / STANDARDS USED:**
- 2020 FLORIDA BUILDING CODE (FBC), 7TH EDITION
 - 2017 FLORIDA BUILDING CODE (FBC), 6TH EDITION
 - ASTM E1300-09
 - ANSI/AF&PA NDS-2018 FOR WOOD CONSTRUCTION
 - ALUMINUM DESIGN MANUAL, ADM-2015
 - AISI S100-16
 - AISC 360-16

GENERAL NOTES.....	1
ELEVATIONS.....	1
GLASS TYPES TABLE.....	1
DESIGN PRESSURES.....	2-9
ANCHOR QUANTITIES.....	10-14
INSTALLATION / ANCHOR SPECS.....	15-17
EXTRUSION PROFILES.....	18
CORNER ASSEMBLY.....	19
PARTS LIST.....	19

PRODUCT REVISED
 as complying with the Florida Building Code
 NOA-No. **20-0406.04**
 Expiration Date: **08/23/2023**
 By: *Manuel Perez*
 Miami-Dade Product Control

Revisions:
 A) UPDATED TO FBC 2020, REVISED ANCHOR TYPE TABLE.
 JR - 03/11/20

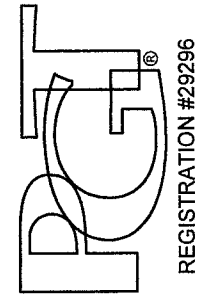
1070 TECHNOLOGY DRIVE N. VENICE, FL 34275 (941) 480-1600	Date	06/30/18	JENS ROSOWSKI	7710NOA-1	A
	Drawn By				
 REGISTRATION #29296 ALUMINUM HORIZ. ROLLER INSTALL. (LM) GENERAL NOTES & ELEVATION	No.	1 OF 19	HR-7710A	Sheet	Title
	Desc.				



 ANTHONY LYNN MILLER
 LICENSE No. 58705
 STATE OF FLORIDA
 PROFESSIONAL ENGINEER
 A. LYNN MILLER, P.E.
 P.E.# 58705

TABLE 2:

Overall Width	Design Pressure (lbs/ft ²) for XO & OX Windows									
	Glass Type: 1 Meeting Rail: Standard									
	21-1/8" Overall Hgt.		37" Overall Hgt.		49" Overall Hgt.		55" Overall Hgt.		63" Overall Hgt.	
20"	+65.0	-65.0	+65.0	-65.0	+65.0	-65.0	+65.0	-65.0	+65.0	-65.0
25"	+65.0	-65.0	+65.0	-65.0	+65.0	-65.0	+65.0	-65.0	+65.0	-65.0
37"	+65.0	-65.0	+65.0	-65.0	+65.0	-65.0	+65.0	-65.0	+65.0	-65.0
49"	+65.0	-65.0	+65.0	-65.0	+65.0	-65.0	+65.0	-65.0	+65.0	-65.0
61"	+65.0	-65.0	+65.0	-65.0	+65.0	-65.0	+65.0	-65.0	+65.0	-65.0
67"	+65.0	-65.0	+65.0	-65.0	+65.0	-65.0	+65.0	-65.0	+65.0	-65.0
74"	+65.0	-65.0	+65.0	-65.0	+65.0	-65.0	+65.0	-65.0	+63.3	-63.3

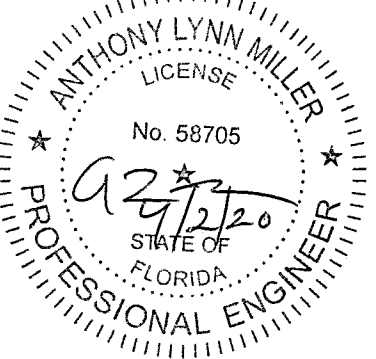
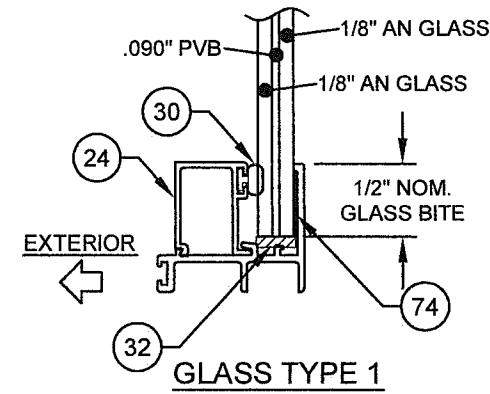
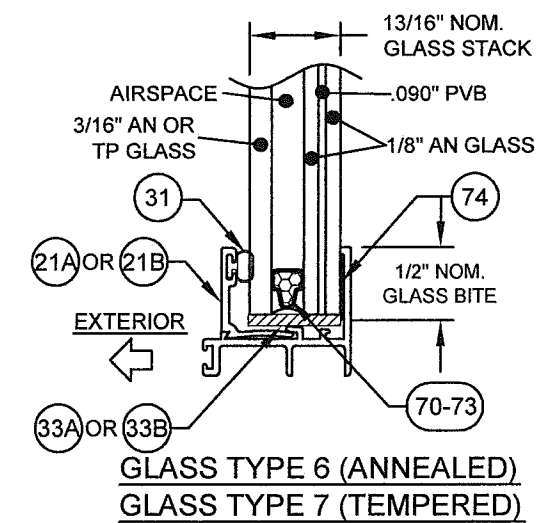
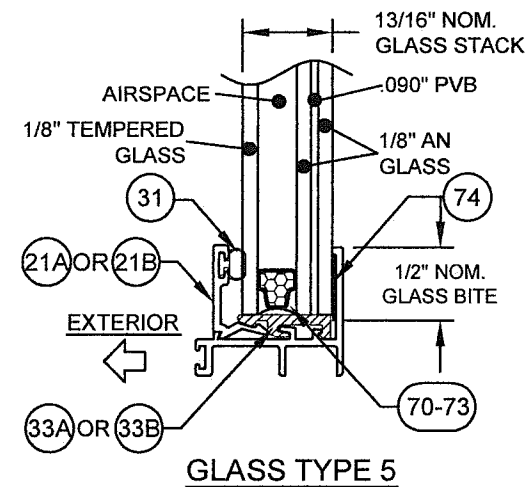
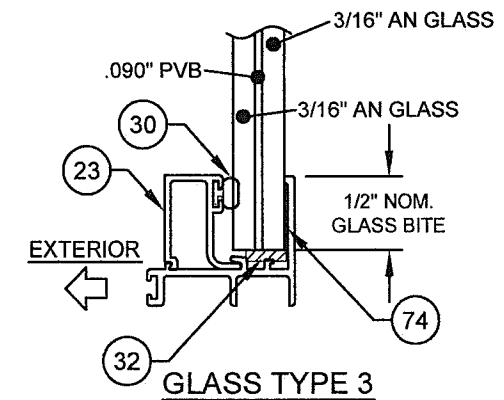
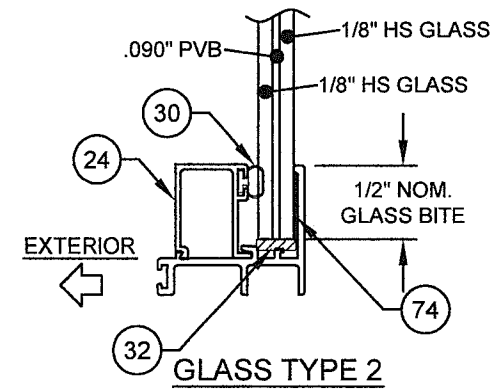

TABLE 3:

Overall Width	Design Pressure (lbs/ft ²) for XO & OX Windows									
	Glass Types: 2, 3, 5, 6, 7 Meeting Rail: Standard									
	21-1/8" Overall Hgt.		37" Overall Hgt.		49" Overall Hgt.		55" Overall Hgt.		63" Overall Hgt.	
20"	+65.0	-80.0	+65.0	-80.0	+65.0	-80.0	+65.0	-80.0	+65.0	-80.0
25"	+65.0	-80.0	+65.0	-80.0	+65.0	-80.0	+65.0	-80.0	+65.0	-80.0
37"	+65.0	-80.0	+65.0	-80.0	+65.0	-80.0	+65.0	-80.0	+65.0	-80.0
49"	+65.0	-80.0	+65.0	-80.0	+65.0	-80.0	+65.0	-80.0	+65.0	-80.0
61"	+65.0	-80.0	+65.0	-80.0	+65.0	-80.0	+65.0	-80.0	+65.0	-80.0
67"	+65.0	-80.0	+65.0	-80.0	+65.0	-80.0	+65.0	-80.0	+65.0	-79.2*
74"	+65.0	-80.0	+65.0	-80.0	+65.0	-80.0	+65.0	-80.0	+65.0	-72.2*

*-80.0 FOR GLASS TYPES 2, 3, 6 & 7



NOTES:

1) OVERALL (TIP TO TIP) DIMENSIONS SHOWN. FOR INTEGRAL FIN AND EQUAL-LEG WINDOWS, SUBTRACT 1" FROM THE TIP TO TIP DIMENSION IN THE TABLE TO DETERMINE THE WINDOW SIZE.

2) FOR SIZES NOT SHOWN, ROUND UP TO THE NEXT AVAILABLE SIZE.

PRODUCT REVISED
as complying with the Florida Building Code
NOA-No. **20-0406.04**
Expiration Date: **08/23/2023**
By: *Manuel Perez*
Miami-Dade Product Control

Revision:
A) NO CHANGES THIS SHEET.
JR - 03/11/20

1070 TECHNOLOGY DRIVE N. VENICE, FL 34275 (941) 480-1600	Date	06/30/18	Rev	A
	Drawn By	JENS ROSOWSKI	No.	7710NOA-1
	Desc.	DESIGN PRESSURE TABLES	Sheet	2 OF 19
	Series	HR-7710A	Registration #	29296

REGISTRATION #29296

ALUMINUM HORIZ. ROLLER INSTALL. (LM)

ANTHONY LYNN MILLER
LICENSE
No. 58705
9/2/20
STATE OF FLORIDA
PROFESSIONAL ENGINEER

A. LYNN MILLER, P.E.
P.E.# 58705

TABLE 4:

Overall Width	Design Pressure (lbs/ft ²) for XO & OX Windows									
	Glass Type: 4 Meeting Rail: Standard									
	21-1/8" Overall Hgt.		37" Overall Hgt.		49" Overall Hgt.		55" Overall Hgt.		63" Overall Hgt.	
20"	+65.0	-80.0	+65.0	-80.0	+65.0	-80.0	+65.0	-80.0	+65.0	-80.0
25"	+65.0	-80.0	+65.0	-80.0	+65.0	-80.0	+65.0	-80.0	+65.0	-80.0
37"	+65.0	-80.0	+65.0	-80.0	+65.0	-80.0	+65.0	-80.0	+65.0	-80.0
49"	+65.0	-80.0	+65.0	-80.0	+65.0	-80.0	+65.0	-80.0	+65.0	-80.0
61"	+65.0	-80.0	+65.0	-80.0	+65.0	-80.0	+65.0	-80.0	+65.0	-76.8
67"	+65.0	-80.0	+65.0	-80.0	+65.0	-80.0	+65.0	-80.0	+65.0	-71.3
74"	+65.0	-80.0	+65.0	-80.0	+65.0	-80.0	+65.0	-77.1	+64.9	-64.9

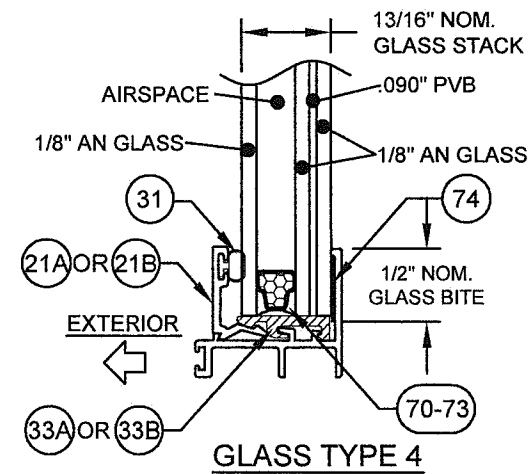

TABLE 5:

Overall Width	Design Pressure (lbs/ft ²) for XO & OX Windows									
	Glass Types: 8 thru 15 Meeting Rail: Standard									
	21-1/8" Overall Hgt.		37" Overall Hgt.		49" Overall Hgt.		55" Overall Hgt.		63" Overall Hgt.	
20"	+80.0	-110.0	+80.0	-110.0	+80.0	-110.0	+80.0	-110.0	+80.0	-110.0
25"	+80.0	-110.0	+80.0	-110.0	+80.0	-110.0	+80.0	-110.0	+80.0	-110.0
37"	+80.0	-110.0	+80.0	-110.0	+80.0	-110.0	+80.0	-110.0	+80.0	-110.0
49"	+80.0	-110.0	+80.0	-110.0	+80.0	-110.0	+80.0	-110.0	+80.0	-110.0
61"	+80.0	-110.0	+80.0	-110.0	+80.0	-110.0	+80.0	-110.0	+80.0	-101.9*
67"	+80.0	-110.0	+80.0	-110.0	+80.0	-110.0	+80.0	-110.0	+80.0	-95.7*
74"	+80.0	-110.0	+80.0	-110.0	+80.0	-110.0	+80.0	-110.0	+80.0	-90.0*

*-110.0 FOR GLASS TYPES 9, 12, 13, 14 & 15

GLASS TYPES 8 - 15
MAY NOT BE USED
WITH INTEGRAL FIN
FRAMES

NOTES:

1) OVERALL (TIP TO TIP) DIMENSIONS SHOWN. FOR INTEGRAL FIN AND EQUAL-LEG WINDOWS, SUBTRACT 1" FROM THE TIP TO TIP DIMENSION IN THE TABLE TO DETERMINE THE WINDOW SIZE.

2) FOR SIZES NOT SHOWN, ROUND UP TO THE NEXT AVAILABLE SIZE.

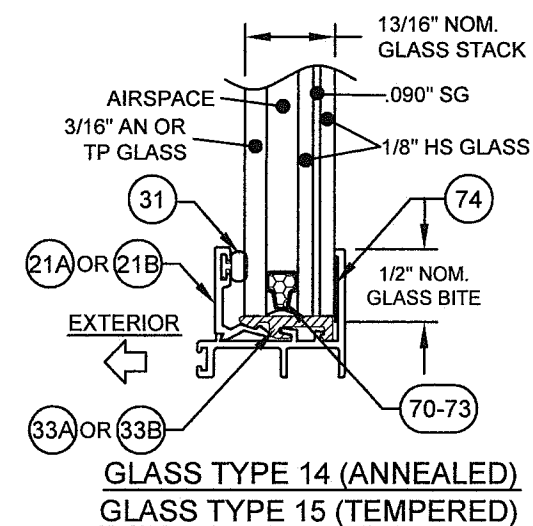
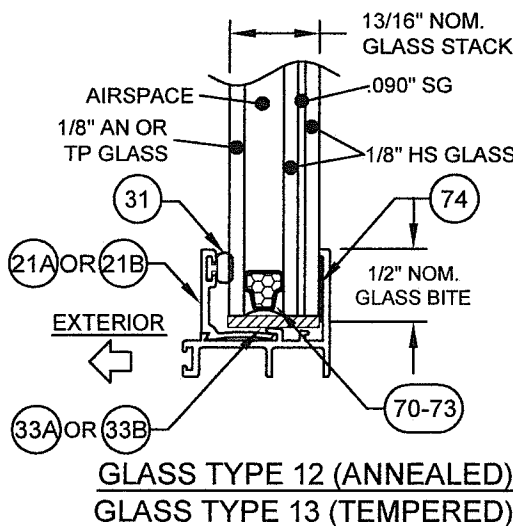
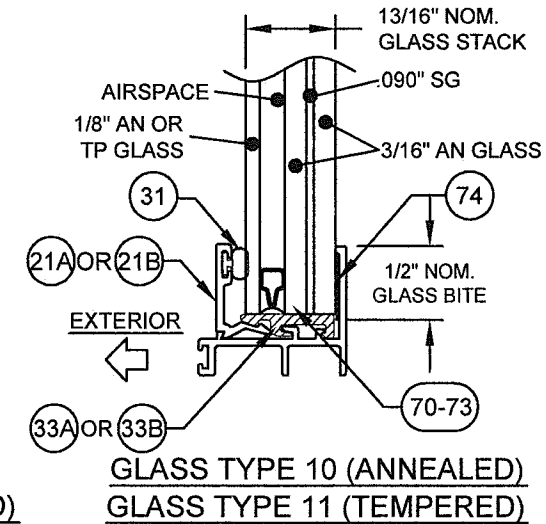
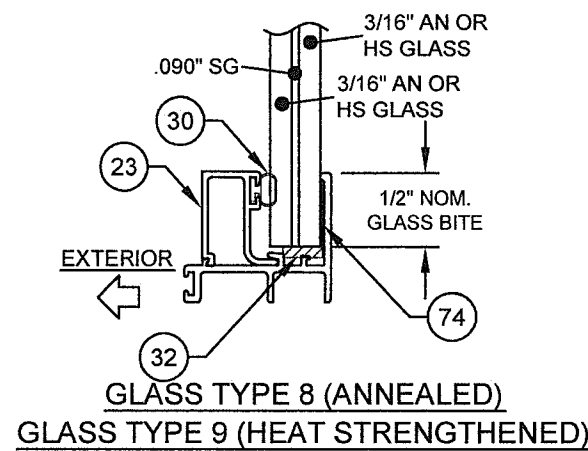

PRODUCT REVISED
as complying with the Florida
Building Code
NOA-No. **20-0406.04**
Expiration Date: **08/23/2023**
By: *Manuel Perez*
Miami-Dade Product Control

Revision: A) NO CHANGES THIS SHEET.
JR - 03/11/20

1070 TECHNOLOGY DRIVE
N. VENICE, FL 34275
(941) 480-1600

REGISTRATION #29296

ALUMINUM HORIZ. ROLLER INSTALL. (LM)

DESIGN PRESSURE TABLES

DATE: 06/30/18
BY: JENS ROSOWSKI
NO. 7710NOA-1
3 OF 19
HR-7710A

Rev. A

ANTHONY LYNN MILLER
LICENSE
No. 58705
9/2/20
STATE OF FLORIDA
PROFESSIONAL ENGINEER

A. LYNN MILLER, P.E.
P.E.# 58705

TABLE 6:

Overall Width	Design Pressure (lbs/ft ²) for XO & OX Windows											
	Glass Types: 8 thru 15				Meeting Rail: Heavy-Duty							
	21-1/8" Overall Hgt.	37" Overall Hgt.	49" Overall Hgt.	55" Overall Hgt.	63" Overall Hgt.	76" Overall Hgt.	21-1/8" Overall Hgt.	37" Overall Hgt.	49" Overall Hgt.	55" Overall Hgt.	63" Overall Hgt.	76" Overall Hgt.
20"	+80.0	-110.0	+80.0	-110.0	+80.0	-110.0	+80.0	-110.0	+80.0	-110.0	+80.0	-110.0
25"	+80.0	-110.0	+80.0	-110.0	+80.0	-110.0	+80.0	-110.0	+80.0	-110.0	+80.0	-110.0
37"	+80.0	-110.0	+80.0	-110.0	+80.0	-110.0	+80.0	-110.0	+80.0	-110.0	+80.0	-110.0
49"	+80.0	-110.0	+80.0	-110.0	+80.0	-110.0	+80.0	-110.0	+80.0	-110.0	+80.0	-110.0
61"	+80.0	-110.0	+80.0	-110.0	+80.0	-110.0	+80.0	-110.0	+80.0	-110.0	+80.0	-110.0
67"	+80.0	-110.0	+80.0	-110.0	+80.0	-110.0	+80.0	-110.0	+80.0	-110.0	+80.0	-109.8*
76"	+80.0	-110.0	+80.0	-110.0	+80.0	-110.0	+80.0	-110.0	+80.0	-110.0	+80.0	-105.8*

*-110.0 FOR GLASS TYPES 8-13 & 15

GLASS TYPES 8 - 15
MAY NOT BE USED
WITH INTEGRAL FIN
FRAMES

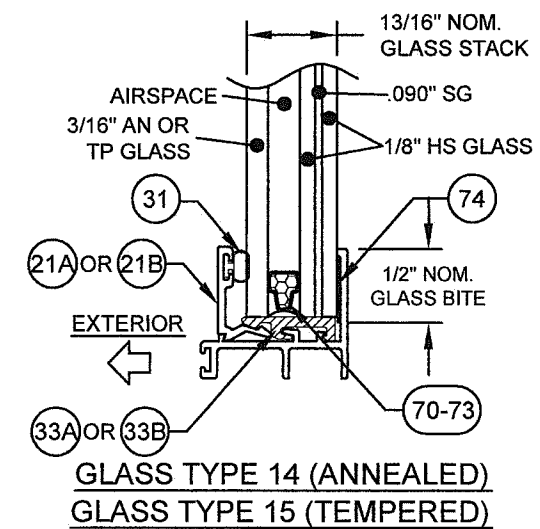
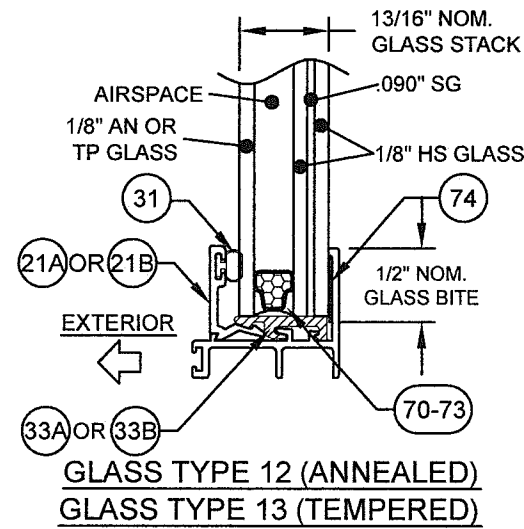
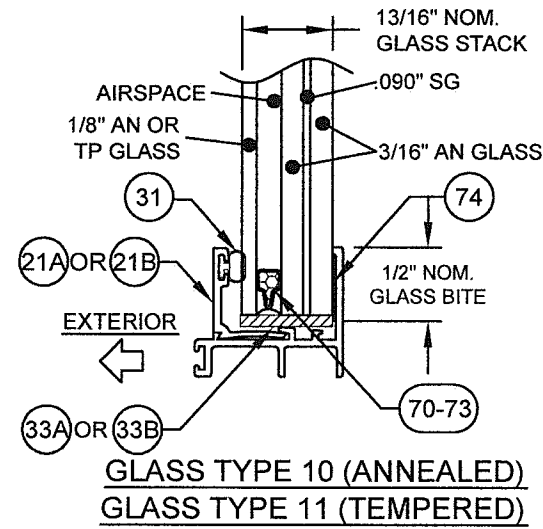
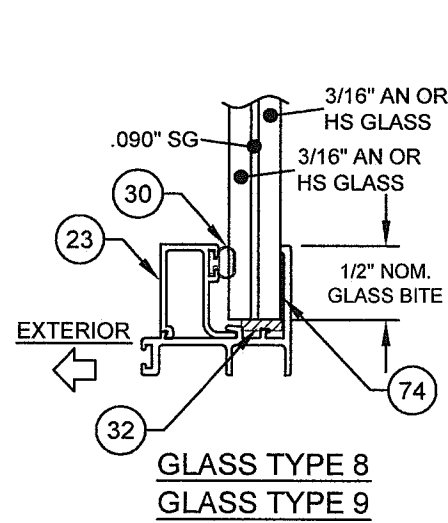

NOTES:

1) OVERALL (TIP TO TIP) DIMENSIONS SHOWN. FOR EQUAL-LEG WINDOWS, SUBTRACT 1" FROM THE TIP TO TIP DIMENSION IN THE TABLE TO DETERMINE THE WINDOW SIZE.

2) FOR SIZES NOT SHOWN, ROUND UP TO THE NEXT AVAILABLE SIZE.

PRODUCT REVISED
as complying with the Florida Building Code
NOA-No. **20-0406.04**
Expiration Date: **08/23/2023**
By: *Manuel Perez*
Miami-Dade Product Control

Revision: A) NO CHANGES THIS SHEET.
JR - 03/11/20

1070 TECHNOLOGY DRIVE N. VENICE, FL 34275 (941) 480-1600	Date	06/30/18	Rev	A
	By	JENS ROSOWSKI	DWG No.	7710NOA-1
REGISTRATION #29296	ALUMINUM HORIZ. ROLLER INSTALL. (LM)	DESIGN PRESSURE TABLES	4 OF 19	HR-7710A

ANTHONY LYNN MILLER
LICENSE
No. 58705
4/2/20
STATE OF FLORIDA
PROFESSIONAL ENGINEER

A. LYNN MILLER, P.E.
P.E.# 58705

TABLE 7:

Overall Width	Sash Configuration	Sash Width Range (in)	Design Pressure (lbs/ft ²) for XOX Windows										Glass Types: 1, 4, 5		
													Meeting Rail: Standard		
			21-1/8" Overall Hgt.	29" Overall Hgt.	37" Overall Hgt.	49" Overall Hgt.	55" Overall Hgt.	63" Overall Hgt.	63" Overall Hgt.	63" Overall Hgt.	63" Overall Hgt.	63" Overall Hgt.	63" Overall Hgt.	63" Overall Hgt.	63" Overall Hgt.
44"	1/4-1/2-1/4	12.038 - 12.052	+60.0	-60.0	+60.0	-60.0	+60.0	-60.0	+60.0	-60.0	+60.0	-60.0	+60.0	-60.0	
	1/3-1/3-1/3	12.053 - 15.008	+60.0	-60.0	+60.0	-60.0	+60.0	-60.0	+60.0	-60.0	+60.0	-60.0	+60.0	-60.0	
49"	1/4-1/2-1/4	12.038 - 13.302	+60.0	-60.0	+60.0	-60.0	+60.0	-60.0	+60.0	-60.0	+60.0	-60.0	+60.0	-60.0	
	1/3-1/3-1/3	13.303 - 16.675	+60.0	-60.0	+60.0	-60.0	+60.0	-60.0	+60.0	-60.0	+60.0	-60.0	+60.0	-60.0	
53-1/8"	1/4-1/2-1/4	12.038 - 14.333	+60.0	-60.0	+60.0	-60.0	+60.0	-60.0	+60.0	-60.0	+60.0	-60.0	+60.0	-60.0	
	1/3-1/3-1/3	14.334 - 18.050	+60.0	-60.0	+60.0	-60.0	+60.0	-60.0	+60.0	-60.0	+60.0	-60.0	+60.0	-60.0	
61"	1/4-1/2-1/4	12.038 - 16.302	+60.0	-60.0	+60.0	-60.0	+60.0	-60.0	+60.0	-60.0	+60.0	-60.0	+60.0	-60.0	
	1/3-1/3-1/3	16.303 - 20.675	+60.0	-60.0	+60.0	-60.0	+60.0	-60.0	+60.0	-60.0	+60.0	-60.0	+60.0	-60.0	
76"	1/4-1/2-1/4	12.038 - 20.052	+60.0	-60.0	+60.0	-60.0	+60.0	-60.0	+60.0	-60.0	+60.0	-60.0	+60.0	-60.0	
	custom	20.053 - 22.185	+60.0	-60.0	+60.0	-60.0	+60.0	-60.0	+60.0	-60.0	+60.0	-60.0	+60.0	-60.0	
92-1/8"	1/3-1/3-1/3	22.186 - 25.675	+60.0	-60.0	+60.0	-60.0	+60.0	-60.0	+60.0	-60.0	+60.0	-60.0	+60.0	-60.0	
	1/4-1/2-1/4	** - 24.082	+60.0	-60.0	+60.0	-60.0	+60.0	-60.0	+60.0	-60.0	+58.2	-58.2	+53.9	-53.9	
	custom	24.083 - 26.185	+60.0	-60.0	+60.0	-60.0	+60.0	-60.0	+60.0	-60.0	+60.0	-60.0	+60.0	-60.0	
97"	1/3-1/3-1/3	26.186 - 31.038	+60.0	-60.0	+60.0	-60.0	+60.0	-60.0	+60.0	-60.0	+60.0	-60.0	+60.0	-60.0	
	1/4-1/2-1/4	** - 25.302	+60.0	-60.0	+60.0	-60.0	+60.0	-60.0	+60.0	-60.0	+58.2	-58.2	+53.9	-53.9	
	custom	25.303 - 27.185	+60.0	-60.0	+60.0	-60.0	+60.0	-60.0	+60.0	-60.0	+60.0	-60.0	+60.0	-60.0	
109"	custom	27.186 - 31.038	+60.0	-60.0	+60.0	-60.0	+60.0	-60.0	+60.0	-60.0	+60.0	-60.0	+60.0	-60.0	
	1/4-1/2-1/4	** - 28.302	+60.0	-60.0	+60.0	-60.0	+60.0	-60.0	+60.0	-60.0	+58.2	-58.2	+53.9	-53.9	
	custom	28.303 - 29.185	+60.0	-60.0	+60.0	-60.0	+60.0	-60.0	+60.0	-60.0	+59.8	-59.8	+51.3	-51.3	
120"	custom	29.186 - 31.038	+60.0	-60.0	+60.0	-60.0	+60.0	-60.0	+60.0	-60.0	+60.0	-60.0	+60.0	-60.0	
	1/4-1/2-1/4	** - 31.038	+60.0	-60.0	+60.0	-60.0	+60.0	-60.0	+60.0	-60.0	+58.2	-58.2	+53.9	-53.9	

** MIN. SASH WIDTH (FLANGE WINDOWS) = $\frac{\text{OVERALL WIDTH} - 57.924}{2}$

** MIN. SASH WIDTH (FIN & EQUAL-LEG WINDOWS) = $\frac{\text{OVERALL WIDTH} - 56.924}{2}$

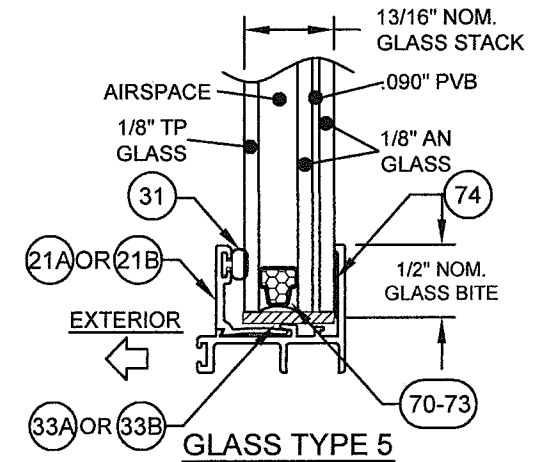
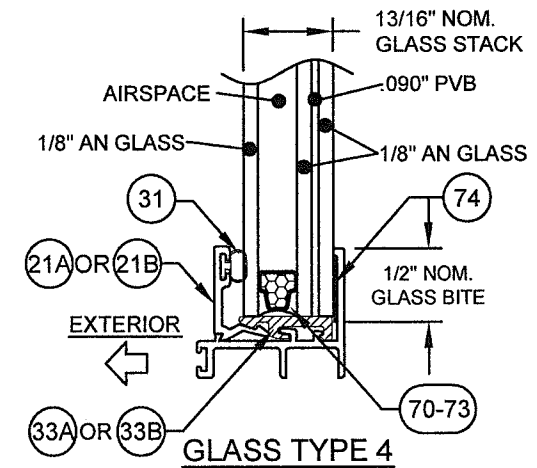
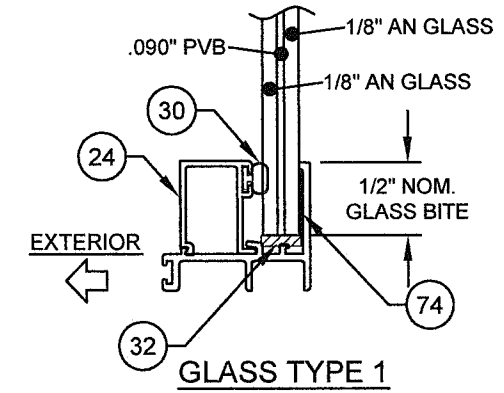

PRODUCT REVISED
 as complying with the Florida Building Code
 NOA-No. **20-0406.04**
 Expiration Date: **08/23/2023**
 By: *Manuel Perez*
 Miami-Dade Product Control

Revision: A) NO CHANGES THIS SHEET.
 JR - 03/11/20

1070 TECHNOLOGY DRIVE
 N. VENICE, FL 34275
 (941) 480-1600

REGISTRATION #29296

ALUMINUM HORIZ. ROLLER INSTALL. (LM)

DESIGN PRESSURE TABLES

DATE: 06/30/18
 DRAWN BY: JENS ROSOWSKI
 NO. 7710NOA-1
 SHEET 5 OF 19
 HR-7710A

ANTHONY LYNN MILLER
 LICENSE
 No. 58705
 4/2/20
 STATE OF FLORIDA
 PROFESSIONAL ENGINEER

A. LYNN MILLER, P.E.
 P.E.# 58705

- NOTES:
- 1) OVERALL (TIP TO TIP) DIMENSIONS SHOWN. FOR INTEGRAL FIN AND EQUAL-LEG WINDOWS, SUBTRACT 1" FROM THE TIP TO TIP DIMENSION IN THE TABLE TO DETERMINE THE WINDOW SIZE.
 - 2) FOR SIZES NOT SHOWN, ROUND UP TO THE NEXT AVAILABLE SIZE.

TABLE 8:

Overall Width	Sash Configuration	Sash Width Range (in)	Design Pressure (lbs/ft ²) for XOX Windows											
			Glass Types: 2, 3 Meeting Rail: Standard											
			21-1/8" Overall Hgt.		29" Overall Hgt.		37" Overall Hgt.		49" Overall Hgt.		55" Overall Hgt.		63" Overall Hgt.	
44"	1/4-1/2-1/4	12.038 - 12.052	+65.0	-80.0	+65.0	-80.0	+65.0	-80.0	+65.0	-80.0	+65.0	-80.0	+65.0	-80.0
	1/3-1/3-1/3	12.053 - 15.008	+65.0	-80.0	+65.0	-80.0	+65.0	-80.0	+65.0	-80.0	+65.0	-80.0	+65.0	-80.0
49"	1/4-1/2-1/4	12.038 - 13.302	+65.0	-80.0	+65.0	-80.0	+65.0	-80.0	+65.0	-80.0	+65.0	-80.0	+65.0	-80.0
	1/3-1/3-1/3	13.303 - 16.675	+65.0	-80.0	+65.0	-80.0	+65.0	-80.0	+65.0	-80.0	+65.0	-80.0	+65.0	-80.0
53-1/8"	1/4-1/2-1/4	12.038 - 14.333	+65.0	-80.0	+65.0	-80.0	+65.0	-80.0	+65.0	-80.0	+65.0	-80.0	+65.0	-80.0
	1/3-1/3-1/3	14.334 - 18.050	+65.0	-80.0	+65.0	-80.0	+65.0	-80.0	+65.0	-80.0	+65.0	-80.0	+65.0	-80.0
61"	1/4-1/2-1/4	12.038 - 16.302	+65.0	-80.0	+65.0	-80.0	+65.0	-80.0	+65.0	-80.0	+65.0	-80.0	+65.0	-80.0
	1/3-1/3-1/3	16.303 - 20.675	+65.0	-80.0	+65.0	-80.0	+65.0	-80.0	+65.0	-80.0	+65.0	-80.0	+65.0	-80.0
76"	1/4-1/2-1/4	12.038 - 20.052	+65.0	-80.0	+65.0	-80.0	+65.0	-80.0	+65.0	-80.0	+65.0	-80.0	+65.0	-80.0
	custom	20.053 - 22.185	+65.0	-80.0	+65.0	-80.0	+65.0	-80.0	+65.0	-80.0	+65.0	-80.0	+65.0	-80.0
	1/3-1/3-1/3	22.186 - 25.675	+65.0	-80.0	+65.0	-80.0	+65.0	-80.0	+65.0	-80.0	+65.0	-80.0	+65.0	-80.0
92-1/8"	1/4-1/2-1/4	** - 24.082	+65.0	-80.0	+65.0	-80.0	+65.0	-80.0	+65.0	-80.0	+65.0	-80.0	+65.0	-80.0
	custom	24.083 - 26.185	+65.0	-80.0	+65.0	-80.0	+65.0	-80.0	+65.0	-80.0	+65.0	-80.0	+65.0	-80.0
	1/3-1/3-1/3	26.186 - 31.048	+65.0	-80.0	+65.0	-80.0	+65.0	-80.0	+65.0	-80.0	+65.0	-80.0	+65.0	-80.0
97"	1/4-1/2-1/4	** - 25.302	+65.0	-80.0	+65.0	-80.0	+65.0	-80.0	+65.0	-80.0	+65.0	-80.0	+65.0	-80.0
	custom	25.303 - 27.185	+65.0	-80.0	+65.0	-80.0	+65.0	-80.0	+65.0	-80.0	+65.0	-80.0	+65.0	-80.0
	1/3-1/3-1/3	27.186 - 32.675	+65.0	-80.0	+65.0	-80.0	+65.0	-80.0	+65.0	-80.0	+65.0	-80.0	+65.0	-80.0
109"	1/4-1/2-1/4	** - 28.302	+65.0	-80.0	+65.0	-80.0	+65.0	-80.0	+65.0	-80.0	+65.0	-80.0	+65.0	-80.0
	custom	28.303 - 30.185	+65.0	-80.0	+65.0	-80.0	+65.0	-80.0	+65.0	-80.0	+65.0	-80.0	+65.0	-80.0
	1/3-1/3-1/3	30.186 - 36.675	+65.0	-80.0	+65.0	-80.0	+65.0	-80.0	+65.0	-80.0	+65.0	-80.0	+65.0	-80.0
113-5/8"	1/4-1/2-1/4	** - 29.463	+65.0	-80.0	+65.0	-80.0	+65.0	-80.0	+65.0	-80.0	+65.0	-80.0	+65.0	-80.0
	custom	29.464 - 33.185	+65.0	-80.0	+65.0	-80.0	+65.0	-80.0	+65.0	-80.0	+65.0	-80.0	+65.0	-80.0
	1/3-1/3-1/3	33.186 - 38.222	+65.0	-80.0	+65.0	-80.0	+65.0	-80.0	+65.0	-80.0	+65.0	-80.0	+65.0	-80.0
120"	1/4-1/2-1/4	** - 31.052	+65.0	-80.0	+65.0	-80.0	+65.0	-80.0	+65.0	-80.0	+65.0	-80.0	+65.0	-80.0
	custom	31.053 - 33.185	+65.0	-80.0	+65.0	-80.0	+65.0	-80.0	+65.0	-80.0	+65.0	-80.0	+65.0	-80.0
	custom	33.186 - 38.222	+65.0	-80.0	+65.0	-80.0	+65.0	-80.0	+65.0	-80.0	+65.0	-80.0	+65.0	-80.0

** MIN. SASH WIDTH (FLANGE WINDOWS) = $\frac{\text{OVERALL WIDTH} - 58.556}{2}$

** MIN. SASH WIDTH (FIN & EQUAL-LEG WINDOWS) = $\frac{\text{OVERALL WIDTH} - 57.556}{2}$

NOTES:

1) OVERALL (TIP TO TIP) DIMENSIONS SHOWN. FOR INTEGRAL FIN AND EQUAL-LEG WINDOWS, SUBTRACT 1" FROM THE TIP TO TIP DIMENSION IN THE TABLE TO DETERMINE THE WINDOW SIZE.

2) FOR SIZES NOT SHOWN, ROUND UP TO THE NEXT AVAILABLE SIZE.

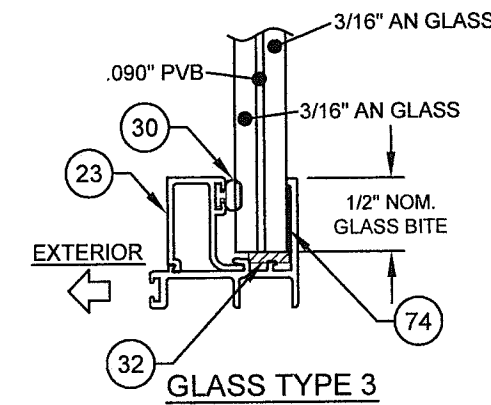
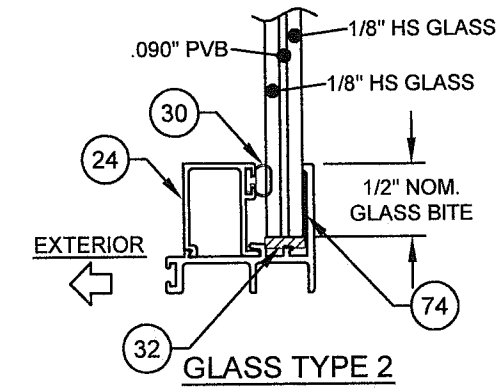

PRODUCT REVISED
as complying with the Florida Building Code
NOA-No. **20-0406.04**
Expiration Date: **08/23/2023**
By: *Manuel Perez*
Miami-Dade Product Control

Revision: A) NO CHANGES THIS SHEET.
JR - 03/11/20

1070 TECHNOLOGY DRIVE N. VENICE, FL 34275 (941) 480-1600	Date	06/30/18	JENS ROSOWSKI	7710NOA-1	A
	Drawn By	JENS ROSOWSKI			
	ALUMINUM HORIZ. ROLLER INSTALL. (LM)		DESIGN PRESSURE TABLES	6 OF 19	HR-7710A
	REGISTRATION #29296				
SERIES		TITLE		SHEET	

ANTHONY LYNN MILLER
 LICENSE
 No. 58705
 9/2/20
 STATE OF FLORIDA
 PROFESSIONAL ENGINEER
 A. LYNN MILLER, P.E.
 P.E.# 58705

TABLE 9:

Overall Width	Sash Configuration	Sash Width Range (in)	Design Pressure (lbs/ft ²) for XOX Windows											
			Glass Types: 6, 7 Meeting Rail: Standard											
			21-1/8" Overall Hgt.	29" Overall Hgt.	37" Overall Hgt.	49" Overall Hgt.	55" Overall Hgt.	63" Overall Hgt.						
44"	1/4-1/2-1/4	12.038 - 12.052	+65.0	-80.0	+65.0	-80.0	+65.0	-80.0	+65.0	-80.0	+65.0	-80.0	+65.0	-80.0
	1/3-1/3-1/3	12.053 - 15.008	+65.0	-80.0	+65.0	-80.0	+65.0	-80.0	+65.0	-80.0	+65.0	-80.0	+65.0	-80.0
49"	1/4-1/2-1/4	12.038 - 13.302	+65.0	-80.0	+65.0	-80.0	+65.0	-80.0	+65.0	-80.0	+65.0	-80.0	+65.0	-80.0
	1/3-1/3-1/3	13.303 - 16.675	+65.0	-80.0	+65.0	-80.0	+65.0	-80.0	+65.0	-80.0	+65.0	-80.0	+65.0	-80.0
53-1/8"	1/4-1/2-1/4	12.038 - 14.333	+65.0	-80.0	+65.0	-80.0	+65.0	-80.0	+65.0	-80.0	+65.0	-80.0	+65.0	-80.0
	1/3-1/3-1/3	14.334 - 18.050	+65.0	-80.0	+65.0	-80.0	+65.0	-80.0	+65.0	-80.0	+65.0	-80.0	+65.0	-80.0
61"	1/4-1/2-1/4	12.038 - 16.302	+65.0	-80.0	+65.0	-80.0	+65.0	-80.0	+65.0	-80.0	+65.0	-80.0	+65.0	-80.0
	1/3-1/3-1/3	16.303 - 20.675	+65.0	-80.0	+65.0	-80.0	+65.0	-80.0	+65.0	-80.0	+65.0	-80.0	+65.0	-80.0
76"	1/4-1/2-1/4	12.038 - 20.052	+65.0	-80.0	+65.0	-80.0	+65.0	-80.0	+65.0	-80.0	+65.0	-80.0	+65.0	-72.9 ^B
	custom	20.053 - 22.185	+65.0	-80.0	+65.0	-80.0	+65.0	-80.0	+65.0	-80.0	+65.0	-80.0	+65.0	-80.0
	1/3-1/3-1/3	22.186 - 25.675	+65.0	-80.0	+65.0	-80.0	+65.0	-80.0	+65.0	-80.0	+65.0	-80.0	+65.0	-80.0
92-1/8"	1/4-1/2-1/4	** - 24.082	+65.0	-80.0	+65.0	-80.0	+65.0	-80.0	+65.0	-80.0	+65.0	-74.1 ^A	+65.0	-67.5 ^B
	custom	24.083 - 26.185	+65.0	-80.0	+65.0	-80.0	+65.0	-80.0	+65.0	-80.0	+65.0	-80.0	+65.0	-80.0
	1/3-1/3-1/3	26.186 - 31.048	+65.0	-80.0	+65.0	-80.0	+65.0	-80.0	+65.0	-80.0	+65.0	-80.0	+65.0	-80.0
97"	1/4-1/2-1/4	** - 25.302	+65.0	-80.0	+65.0	-80.0	+65.0	-80.0	+65.0	-80.0	+65.0	-74.1 ^A	+65.0	-67.5 ^B
	custom	25.303 - 27.185	+65.0	-80.0	+65.0	-80.0	+65.0	-80.0	+65.0	-80.0	+65.0	-80.0	+65.0	-77.9
	1/3-1/3-1/3	27.186 - 32.675	+65.0	-80.0	+65.0	-80.0	+65.0	-80.0	+65.0	-80.0	+65.0	-80.0	+65.0	-80.0
109"	1/4-1/2-1/4	** - 28.302	+65.0	-80.0	+65.0	-80.0	+65.0	-80.0	+65.0	-80.0	+65.0	-74.1 ^A	+65.0	-67.5 ^B
	custom	28.303 - 30.185	+65.0	-80.0	+65.0	-80.0	+65.0	-80.0	+65.0	-80.0	+65.0	-80.0	+65.0	-72.0
	1/3-1/3-1/3	30.186 - 36.675	+65.0	-80.0	+65.0	-80.0	+65.0	-80.0	+65.0	-80.0	+65.0	-80.0	+65.0	-75.8
113-5/8"	1/4-1/2-1/4	** - 29.463	+65.0	-80.0	+65.0	-80.0	+65.0	-80.0	+65.0	-80.0	+65.0	-74.1 ^A	+65.0	-67.5 ^B
	custom	29.464 - 33.185	+65.0	-80.0	+65.0	-80.0	+65.0	-80.0	+65.0	-80.0	+65.0	-80.0	+65.0	-70.6
	1/3-1/3-1/3	33.186 - 38.222	+65.0	-80.0	+65.0	-80.0	+65.0	-80.0	+65.0	-80.0	+65.0	-80.0	+65.0	-76.9
120"	1/4-1/2-1/4	** - 31.052	+65.0	-80.0	+65.0	-80.0	+65.0	-80.0	+65.0	-80.0	+65.0	-74.1 ^A	+65.0	-67.5 ^B
	custom	31.053 - 33.185	+65.0	-80.0	+65.0	-80.0	+65.0	-80.0	+65.0	-80.0	+65.0	-75.7	+65.0	-68.4
	custom	33.186 - 38.222	+65.0	-80.0	+65.0	-80.0	+65.0	-80.0	+65.0	-80.0	+65.0	-80.0	+65.0	-71.3

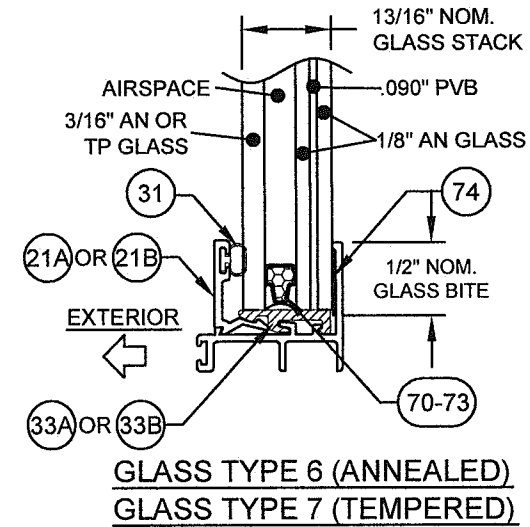

PRODUCT REVISED
 as complying with the Florida Building Code
NOA-No. 20-0406.04
Expiration Date: 08/23/2023
 By: *Manuel Perez*
 Miami-Dade Product Control

Revision: A) NO CHANGES THIS SHEET.
 JR - 03/11/20

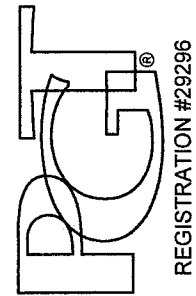
1070 TECHNOLOGY DRIVE N. VENICE, FL 34275 (941) 480-1600	Date	06/30/18	JENS ROSOWSKI	7710NOA-1	A
	Drawn By	JENS ROSOWSKI			
	ALUMINUM HORIZ. ROLLER INSTALL. (LM)		DESIGN PRESSURE TABLES	7 OF 19	A
	REGISTRATION #29296				
HR-7710A		Series Desc. Title		7 OF 19	

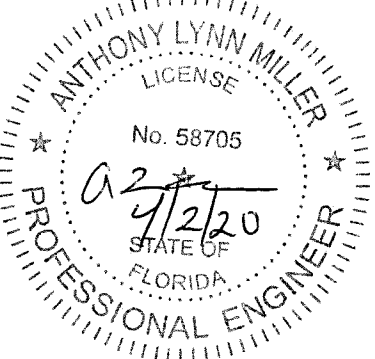

 ANTHONY LYNN MILLER
 LICENSE
 No. 58705
 4/2/20
 STATE OF FLORIDA
 PROFESSIONAL ENGINEER
 A. LYNN MILLER, P.E.
 P.E.# 58705

** MIN. SASH WIDTH (FLANGE WINDOWS) = $\frac{\text{OVERALL WIDTH} - 58.556}{2}$

^A-80.0 FOR GLASS TYPE 7
^B-75.0 FOR GLASS TYPE 7

** MIN. SASH WIDTH (FIN & EQUAL-LEG WINDOWS) = $\frac{\text{OVERALL WIDTH} - 57.556}{2}$

NOTES:

1) OVERALL (TIP TO TIP) DIMENSIONS SHOWN. FOR INTEGRAL FIN AND EQUAL-LEG WINDOWS, SUBTRACT 1" FROM THE TIP TO TIP DIMENSION IN THE TABLE TO DETERMINE THE WINDOW SIZE.

2) FOR SIZES NOT SHOWN, ROUND UP TO THE NEXT AVAILABLE SIZE.

TABLE 10:

Overall Width	Sash Configuration	Sash Width Range (in)	Design Pressure (lbs/ft ²) for XOX Windows											
			Glass Types: 8, 10, 11 Meeting Rail: Standard											
			21-1/8" Overall Hgt.		29" Overall Hgt.		37" Overall Hgt.		49" Overall Hgt.		55" Overall Hgt.		63" Overall Hgt.	
44"	1/4-1/2-1/4	12.038 - 12.052	+80.0	-110.0	+80.0	-110.0	+80.0	-110.0	+80.0	-110.0	+80.0	-110.0	+80.0	-110.0
	1/3-1/3-1/3	12.053 - 15.008	+80.0	-110.0	+80.0	-110.0	+80.0	-110.0	+80.0	-110.0	+80.0	-110.0	+80.0	-110.0
49"	1/4-1/2-1/4	12.038 - 13.302	+80.0	-110.0	+80.0	-110.0	+80.0	-110.0	+80.0	-110.0	+80.0	-110.0	+80.0	-110.0
	1/3-1/3-1/3	13.303 - 16.675	+80.0	-110.0	+80.0	-110.0	+80.0	-110.0	+80.0	-110.0	+80.0	-110.0	+80.0	-110.0
53-1/8"	1/4-1/2-1/4	12.038 - 14.333	+80.0	-110.0	+80.0	-110.0	+80.0	-110.0	+80.0	-110.0	+80.0	-110.0	+80.0	-110.0
	1/3-1/3-1/3	14.334 - 18.050	+80.0	-110.0	+80.0	-110.0	+80.0	-110.0	+80.0	-110.0	+80.0	-110.0	+80.0	-110.0
61"	1/4-1/2-1/4	12.038 - 16.302	+80.0	-110.0	+80.0	-110.0	+80.0	-110.0	+80.0	-110.0	+80.0	-110.0	+80.0	-110.0
	1/3-1/3-1/3	16.303 - 20.675	+80.0	-110.0	+80.0	-110.0	+80.0	-110.0	+80.0	-110.0	+80.0	-110.0	+80.0	-110.0
76"	1/4-1/2-1/4	12.038 - 20.052	+80.0	-110.0	+80.0	-110.0	+80.0	-110.0	+80.0	-110.0	+80.0	-110.0	+80.0	-99.2
	custom	20.053 - 22.185	+80.0	-110.0	+80.0	-110.0	+80.0	-110.0	+80.0	-110.0	+80.0	-110.0	+80.0	-110.0
	1/3-1/3-1/3	22.186 - 25.675	+80.0	-110.0	+80.0	-110.0	+80.0	-110.0	+80.0	-110.0	+80.0	-110.0	+80.0	-110.0
92-1/8"	1/4-1/2-1/4	** - 24.082	+80.0	-110.0	+80.0	-110.0	+80.0	-110.0	+80.0	-110.0	+80.0	-101.0	+80.0	-90.5
	custom	24.083 - 26.185	+80.0	-110.0	+80.0	-110.0	+80.0	-110.0	+80.0	-110.0	+80.0	-110.0	+80.0	-105.2
	1/3-1/3-1/3	26.186 - 31.048	+80.0	-110.0	+80.0	-110.0	+80.0	-110.0	+80.0	-110.0	+80.0	-110.0	+80.0	-102.3
97"	1/4-1/2-1/4	** - 25.302	+80.0	-110.0	+80.0	-110.0	+80.0	-110.0	+80.0	-110.0	+80.0	-101.0	+80.0	-90.5
	custom	25.303 - 27.185	+80.0	-110.0	+80.0	-110.0	+80.0	-110.0	+80.0	-110.0	+80.0	-110.0	+80.0	-102.7
	1/3-1/3-1/3	27.186 - 32.675	+80.0	-110.0	+80.0	-110.0	+80.0	-110.0	+80.0	-110.0	+80.0	-110.0	+80.0	-98.9
109"	1/4-1/2-1/4	** - 28.302	+80.0	-110.0	+80.0	-110.0	+80.0	-110.0	+80.0	-110.0	+80.0	-101.0	+80.0	-90.5
	custom	28.303 - 30.185	+80.0	-110.0	+80.0	-110.0	+80.0	-110.0	+80.0	-110.0	+80.0	-110.0	+80.0	-97.3
	1/3-1/3-1/3	30.186 - 36.675	+80.0	-110.0	+80.0	-110.0	+80.0	-110.0	+80.0	-110.0	+80.0	-110.0	+80.0	-92.9
113-5/8"	1/4-1/2-1/4	** - 29.463	+80.0	-110.0	+80.0	-110.0	+80.0	-110.0	+80.0	-110.0	+80.0	-101.0	+80.0	-90.5
	custom	29.464 - 33.185	+80.0	-110.0	+80.0	-110.0	+80.0	-110.0	+80.0	-110.0	+80.0	-108.5	+80.0	-94.1
	1/3-1/3-1/3	33.186 - 38.222	+80.0	-110.0	+80.0	-110.0	+80.0	-110.0	+80.0	-110.0	+80.0	-110.0	+80.0	-92.3
120"	1/4-1/2-1/4	** - 31.052	+80.0	-110.0	+80.0	-110.0	+80.0	-110.0	+80.0	-110.0	+80.0	-101.0	+80.0	-90.5
	custom	31.053 - 33.185	+80.0	-110.0	+80.0	-110.0	+80.0	-110.0	+80.0	-110.0	+80.0	-102.9	+80.0	-91.5
	custom	33.186 - 38.222	+80.0	-110.0	+80.0	-110.0	+80.0	-110.0	+80.0	-110.0	+80.0	-110.0	+80.0	-90.6

** MIN. SASH WIDTH (FLANGE WINDOWS) = $\frac{\text{OVERALL WIDTH} - 58.556}{2}$

** MIN. SASH WIDTH (EQUAL-LEG WINDOWS) = $\frac{\text{OVERALL WIDTH} - 57.556}{2}$

NOTES:

1) OVERALL (TIP TO TIP) DIMENSIONS SHOWN. FOR EQUAL-LEG WINDOWS, SUBTRACT 1" FROM THE TIP TO TIP DIMENSION IN THE TABLE TO DETERMINE THE WINDOW SIZE.

2) FOR SIZES NOT SHOWN, ROUND UP TO THE NEXT AVAILABLE SIZE.

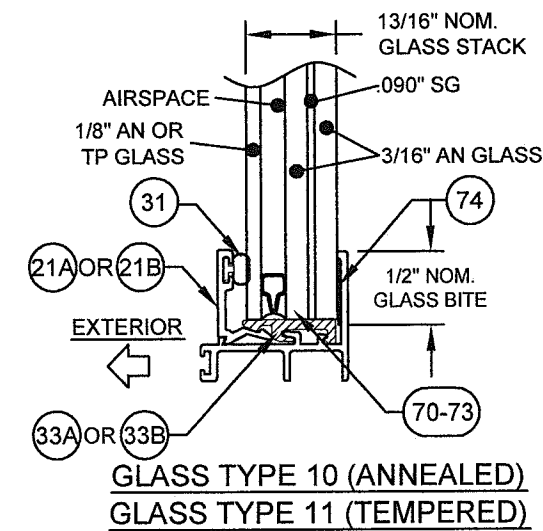
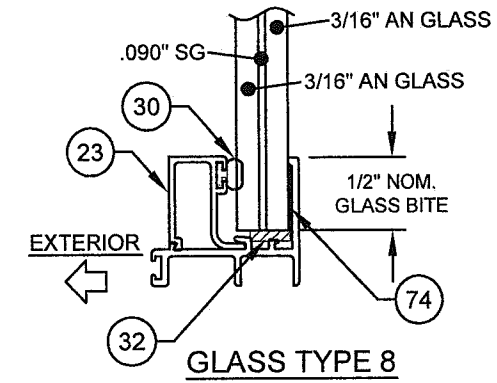

GLASS TYPES 8 - 15
MAY NOT BE USED
WITH INTEGRAL FIN
FRAMES

PRODUCT REVISED
as complying with the Florida
Building Code
NOA-No. **20-0406.04**
Expiration Date: **08/23/2023**
By: *Manuel Perez*
Miami-Dade Product Control

Revision: A) NO CHANGES THIS SHEET.
JR - 03/11/20

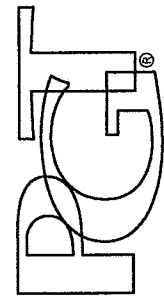
1070 TECHNOLOGY DRIVE N. VENICE, FL 34275 (941) 480-1600	Date	06/30/18	JENS ROSOWSKI	7710NOA-1	A
	By	JENS ROSOWSKI			
 REGISTRATION #29296 ALUMINUM HORIZ. ROLLER INSTALL. (LM) DESIGN PRESSURE TABLES HR-7710A	No.	7710NOA-1	8 OF 19	Sheet	Series
	Desc.	ALUMINUM HORIZ. ROLLER INSTALL. (LM)			

ANTHONY LYNN MILLER
LICENSE
No. 58705
02/2/20
STATE OF
FLORIDA
PROFESSIONAL ENGINEER
A. LYNN MILLER, P.E.
P.E.# 58705

TABLE 11:

Overall Width	Sash Configuration	Sash Width Range (in)	Design Pressure (lbs/ft ²) for XOX Windows											
			Glass Types: 9, 12, 13, 14, 15 Meeting Rail: Standard											
			21-1/8" Overall Hgt.		29" Overall Hgt.		37" Overall Hgt.		49" Overall Hgt.		55" Overall Hgt.		63" Overall Hgt.	
44"	1/4-1/2-1/4	12.038 - 12.052	+80.0	-110.0	+80.0	-110.0	+80.0	-110.0	+80.0	-110.0	+80.0	-110.0	+80.0	-110.0
	1/3-1/3-1/3	12.053 - 15.008	+80.0	-110.0	+80.0	-110.0	+80.0	-110.0	+80.0	-110.0	+80.0	-110.0	+80.0	-110.0
49"	1/4-1/2-1/4	12.038 - 13.302	+80.0	-110.0	+80.0	-110.0	+80.0	-110.0	+80.0	-110.0	+80.0	-110.0	+80.0	-110.0
	1/3-1/3-1/3	13.303 - 16.675	+80.0	-110.0	+80.0	-110.0	+80.0	-110.0	+80.0	-110.0	+80.0	-110.0	+80.0	-110.0
53-1/8"	1/4-1/2-1/4	12.038 - 14.333	+80.0	-110.0	+80.0	-110.0	+80.0	-110.0	+80.0	-110.0	+80.0	-110.0	+80.0	-110.0
	1/3-1/3-1/3	14.334 - 18.050	+80.0	-110.0	+80.0	-110.0	+80.0	-110.0	+80.0	-110.0	+80.0	-110.0	+80.0	-110.0
61"	1/4-1/2-1/4	12.038 - 16.302	+80.0	-110.0	+80.0	-110.0	+80.0	-110.0	+80.0	-110.0	+80.0	-110.0	+80.0	-110.0
	1/3-1/3-1/3	16.303 - 20.675	+80.0	-110.0	+80.0	-110.0	+80.0	-110.0	+80.0	-110.0	+80.0	-110.0	+80.0	-110.0
76"	1/4-1/2-1/4	12.038 - 20.052	+80.0	-110.0	+80.0	-110.0	+80.0	-110.0	+80.0	-110.0	+80.0	-110.0	+80.0	-110.0
	custom	20.053 - 22.185	+80.0	-110.0	+80.0	-110.0	+80.0	-110.0	+80.0	-110.0	+80.0	-110.0	+80.0	-110.0
	1/3-1/3-1/3	22.186 - 25.675	+80.0	-110.0	+80.0	-110.0	+80.0	-110.0	+80.0	-110.0	+80.0	-110.0	+80.0	-110.0
92-1/8"	1/4-1/2-1/4	** - 24.082	+80.0	-110.0	+80.0	-110.0	+80.0	-110.0	+80.0	-110.0	+80.0	-110.0	+80.0	-106.7*
	custom	24.083 - 26.185	+80.0	-110.0	+80.0	-110.0	+80.0	-110.0	+80.0	-110.0	+80.0	-110.0	+80.0	-110.0
	1/3-1/3-1/3	26.186 - 31.048	+80.0	-110.0	+80.0	-110.0	+80.0	-110.0	+80.0	-110.0	+80.0	-110.0	+80.0	-110.0
97"	1/4-1/2-1/4	** - 25.302	+80.0	-110.0	+80.0	-110.0	+80.0	-110.0	+80.0	-110.0	+80.0	-110.0	+80.0	-106.7*
	custom	25.303 - 27.185	+80.0	-110.0	+80.0	-110.0	+80.0	-110.0	+80.0	-110.0	+80.0	-110.0	+80.0	-110.0
	1/3-1/3-1/3	27.186 - 32.675	+80.0	-110.0	+80.0	-110.0	+80.0	-110.0	+80.0	-110.0	+80.0	-110.0	+80.0	-110.0
109"	1/4-1/2-1/4	** - 28.302	+80.0	-110.0	+80.0	-110.0	+80.0	-110.0	+80.0	-110.0	+80.0	-110.0	+80.0	-106.7*
	custom	28.303 - 30.185	+80.0	-110.0	+80.0	-110.0	+80.0	-110.0	+80.0	-110.0	+80.0	-110.0	+80.0	-110.0
	1/3-1/3-1/3	30.186 - 36.675	+80.0	-110.0	+80.0	-110.0	+80.0	-110.0	+80.0	-110.0	+80.0	-110.0	+80.0	-110.0
113-5/8"	1/4-1/2-1/4	** - 29.463	+80.0	-110.0	+80.0	-110.0	+80.0	-110.0	+80.0	-110.0	+80.0	-110.0	+80.0	-106.7*
	custom	29.464 - 33.185	+80.0	-110.0	+80.0	-110.0	+80.0	-110.0	+80.0	-110.0	+80.0	-110.0	+80.0	-110.0
	1/3-1/3-1/3	33.186 - 38.222	+80.0	-110.0	+80.0	-110.0	+80.0	-110.0	+80.0	-110.0	+80.0	-110.0	+80.0	-110.0
120"	1/4-1/2-1/4	** - 31.052	+80.0	-110.0	+80.0	-110.0	+80.0	-110.0	+80.0	-110.0	+80.0	-110.0	+80.0	-106.7*
	custom	31.053 - 33.185	+80.0	-110.0	+80.0	-110.0	+80.0	-110.0	+80.0	-110.0	+80.0	-110.0	+80.0	-107.8
	custom	33.186 - 38.222	+80.0	-110.0	+80.0	-110.0	+80.0	-110.0	+80.0	-110.0	+80.0	-110.0	+80.0	-110.0

** MIN. SASH WIDTH (FLANGE WINDOWS) = $\frac{\text{OVERALL WIDTH} - 58.556}{2}$

** MIN. SASH WIDTH (EQUAL-LEG WINDOWS) = $\frac{\text{OVERALL WIDTH} - 57.556}{2}$

*-110.0 FOR GLASS TYPES 9, 12, 13 & 15

GLASS TYPES 8 - 15
MAY NOT BE USED
WITH INTEGRAL FIN
FRAMES

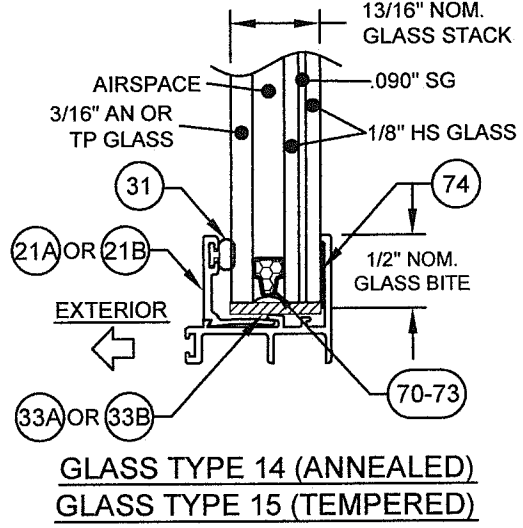
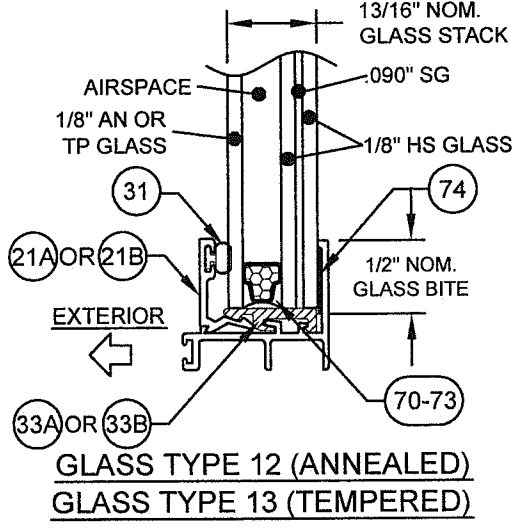
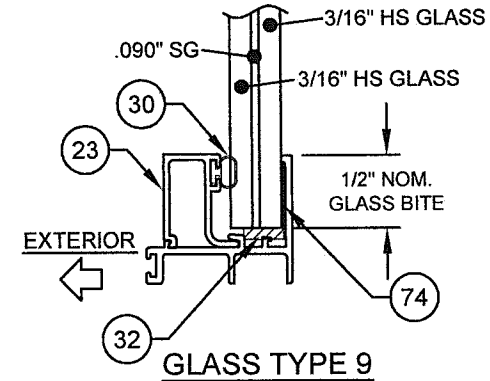

PRODUCT REVISED
as complying with the Florida
Building Code
NOA-No. **20-0406.04**
Expiration Date: **08/23/2023**
By: *Manuel Perez*
Miami-Dade Product Control

Revision: A) NO CHANGES THIS SHEET.
JR - 03/11/20

1070 TECHNOLOGY DRIVE N. VENICE, FL 34275 (941) 480-1600	Date	06/30/18	JENS ROSOWSKI	7710NOA-1	A
	Drawn By				
REGISTRATION #29296	ALUMINUM HORIZ. ROLLER INSTALL. (LM)		DESIGN PRESSURE TABLES	HR-7710A	9 OF 19
	7710NOA-1				

ANTHONY LYNN MILLER
LICENSE
No. 58705
08/23/20
STATE OF FLORIDA
PROFESSIONAL ENGINEER
A. LYNN MILLER, P.E.
P.E.# 58705

- NOTES:
- OVERALL (TIP TO TIP) DIMENSIONS SHOWN. FOR EQUAL-LEG WINDOWS, SUBTRACT 1" FROM THE TIP TO TIP DIMENSION IN THE TABLE TO DETERMINE THE WINDOW SIZE.
 - FOR SIZES NOT SHOWN, ROUND UP TO THE NEXT AVAILABLE SIZE.

TABLE 12:

Overall Width	Anchor Quantities for XO & OX Windows									
	Glass Types: 1 thru 7 Meeting Rail: Standard									
	21-1/8" Overall Hgt.		37" Overall Hgt.		49" Overall Hgt.		55" Overall Hgt.		63" Overall Hgt.	
	Head & Sill	Jamb	Head & Sill	Jamb	Head & Sill	Jamb	Head & Sill	Jamb	Head & Sill	Jamb
20"	1+C2+1	2	1+C2+1	2	1+C2+1	3	1+C2+1	3	1+C2+1	3
25"	1+C2+1	2	1+C2+1	2	1+C2+1	3	1+C2+1	3	1+C2+1	3
37"	1+C2+1	2	1+C2+1	2	1+C2+1	3	1+C2+1	3	1+C2+1	3
49"	1+C2+1	2	1+C2+1	2	1+C2+1	3	1+C2+1	3	1+C2+1	3
61"	1+C2+1	2	1+C2+1	2	1+C2+1	3	1+C2+1	3	1+C2+1	3
67"	1+C2+1	2	1+C2+1	2	1+C2+1	3	1+C2+1	3	1+C3+1 *	3
74"	1+C2+1	2	1+C2+1	2	1+C2+1	3	1+C2+1	3	1+C3+1 *	3

*1+C2+1 FOR GLASS TYPES 1, 4 & 5

TABLE 13:

Overall Width	Anchor Quantities for XO & OX Windows									
	Glass Types: 8 thru 15 Meeting Rail: Standard									
	21-1/8" Overall Hgt.		37" Overall Hgt.		49" Overall Hgt.		55" Overall Hgt.		63" Overall Hgt.	
	Head & Sill	Jamb	Head & Sill	Jamb	Head & Sill	Jamb	Head & Sill	Jamb	Head & Sill	Jamb
20"	1+C2+1	2	1+C2+1	2	1+C2+1	3	1+C2+1	3	1+C2+1	3
25"	1+C2+1	2	1+C2+1	2	1+C2+1	3	1+C2+1	3	1+C2+1	3
37"	1+C2+1	2	1+C2+1	2	1+C2+1	3	1+C2+1	3	1+C2+1	3
49"	1+C2+1	2	1+C2+1	2	1+C2+1	3	1+C2+1	3	1+C3+1	3
61"	1+C2+1	2	1+C2+1	2	1+C2+1	3	1+C3+1	3	1+C3+1	3
67"	1+C2+1	2	2+C2+2	2	2+C2+2	3	2+C3+2	3	2+C3+2	3
74"	2+C2+2	2	2+C2+2	2	2+C2+2	3	2+C3+2	3	2+C3+2	4

TABLE 14:

Overall Width	Anchor Quantities for XO & OX Windows											
	Glass Types: 8 thru 15 Meeting Rail: Heavy-Duty											
	21-1/8" Overall Hgt.		37" Overall Hgt.		49" Overall Hgt.		55" Overall Hgt.		63" Overall Hgt.		76" Overall Hgt.	
	Head & Sill	Jamb	Head & Sill	Jamb	Head & Sill	Jamb	Head & Sill	Jamb	Head & Sill	Jamb	Head & Sill	Jamb
20"	1+C2+1	2	1+C2+1	2	1+C2+1	3	1+C2+1	3	1+C2+1	3	1+C2+1	4
25"	1+C2+1	2	1+C2+1	2	1+C2+1	3	1+C2+1	3	1+C2+1	3	1+C2+1	4
37"	1+C2+1	2	1+C2+1	2	1+C2+1	3	1+C2+1	3	1+C2+1	3	1+C3+1	4
49"	1+C2+1	2	1+C2+1	2	1+C2+1	3	1+C2+1	3	1+C3+1	3	1+C3+1	4
61"	1+C2+1	2	1+C2+1	2	1+C2+1	3	1+C3+1	3	1+C3+1	3	1+C4+1	4
67"	1+C2+1	2	2+C2+2	2	2+C2+2	3	2+C3+2	3	2+C3+2	3	2+C4+2	4
76"	2+C2+2	2	2+C2+2	2	2+C3+2	3	2+C3+2	3	2+C3+2	4	2+C4+2	5

GUIDE TO USING ANCHOR QUANTITY TABLES FOR XO/OX WINDOWS:

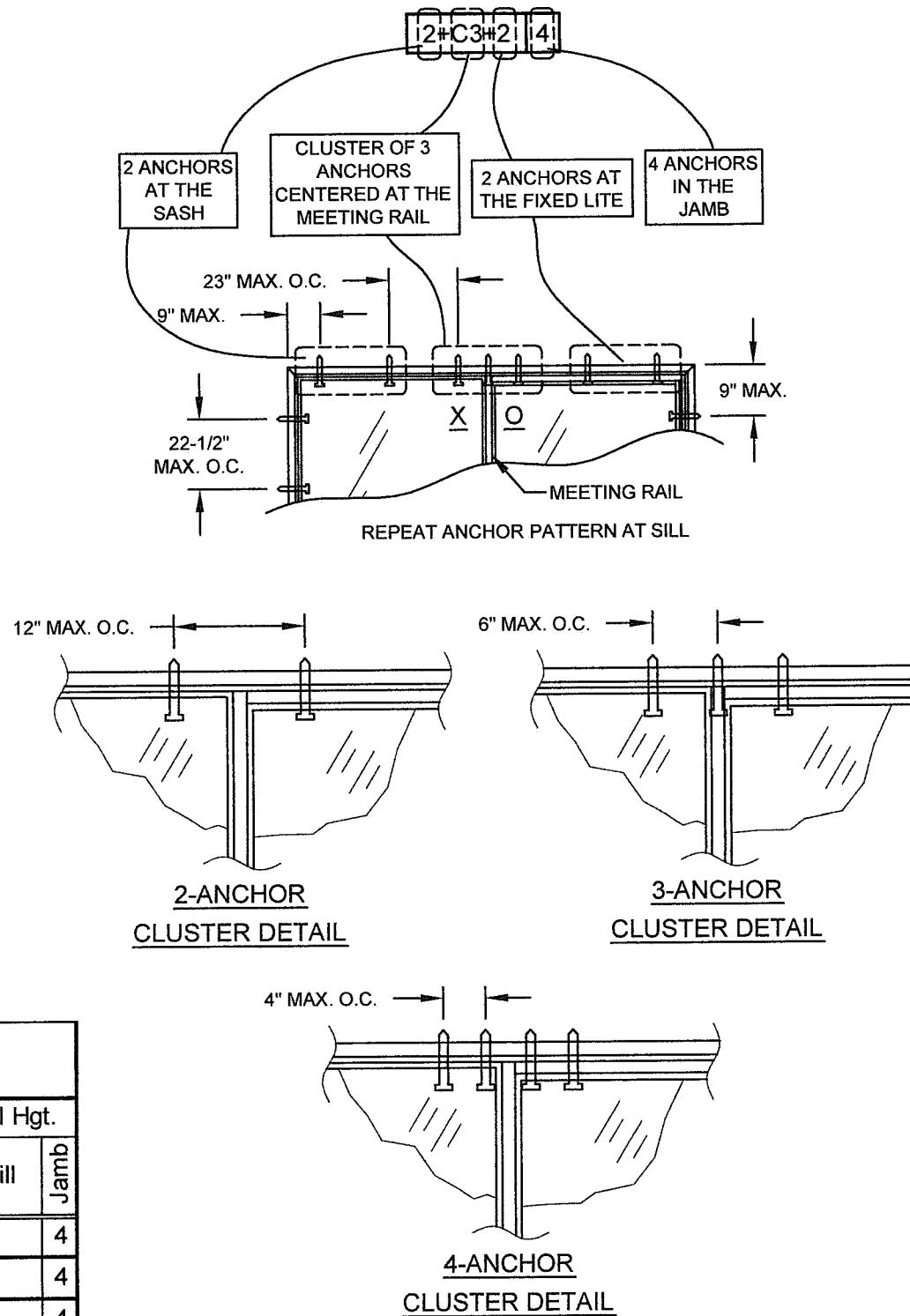

NOTES:

- 1) OVERALL (TIP TO TIP) DIMENSIONS SHOWN. FOR EQUAL-LEG WINDOWS, SUBTRACT 1" FROM THE TIP TO TIP DIMENSION IN THE TABLE TO DETERMINE THE WINDOW SIZE.
- 2) FOR SIZES NOT SHOWN, ROUND UP TO THE NEXT AVAILABLE SIZE.

PRODUCT REVISED
as complying with the Florida Building Code
NOA-No. **20-0406.04**
Expiration Date: **08/23/2023**
By: *Manuel Perez*
Miami-Dade Product Control

Revision: A) NO CHANGES THIS SHEET.
JR - 03/11/20

1070 TECHNOLOGY DRIVE
N. VENICE, FL 34275
(941) 480-1600

REGISTRATION #29296

ALUMINUM HORIZ. ROLLER INSTALL. (LM) 06/30/18
ANCHOR QUANTITY TABLES JENS ROSOWSKI
HR-7710A 10 OF 19 7710NOA-1 A

ANTHONY LYNN MILLER
LICENSE
No. 58705
9/2/20
STATE OF FLORIDA
PROFESSIONAL ENGINEER
A. LYNN MILLER, P.E.
P.E.# 58705

TABLE 15:

Overall Width	Sash Configuration	Sash Width Range (in)	Anchor Quantities for XOX Windows															
			21-1/8" Overall Hgt.						29" Overall Hgt.		37" Overall Hgt.		49" Overall Hgt.		55" Overall Hgt.		63" Overall Hgt.	
			Head & Sill		Jamb	Head & Sill		Jamb	Head & Sill		Jamb	Head & Sill		Jamb	Head & Sill		Jamb	
44"	1/4-1/2-1/4	12.038 - 12.052	1+C2+1+C2+1	2	1+C2+1+C2+1	2	1+C2+1+C2+1	2	1+C2+1+C2+1	2	1+C2+1+C2+1	3	1+C2+1+C2+1	3	1+C2+1+C2+1	3		
	1/3-1/3-1/3	12.053 - 15.008	1+C2+1+C2+1	2	1+C2+1+C2+1	2	1+C2+1+C2+1	2	1+C2+1+C2+1	2	1+C2+1+C2+1	3	1+C2+1+C2+1	3	1+C2+1+C2+1	3		
49"	1/4-1/2-1/4	12.038 - 13.302	1+C2+1+C2+1	2	1+C2+1+C2+1	2	1+C2+1+C2+1	2	1+C2+1+C2+1	2	1+C2+1+C2+1	3	1+C2+1+C2+1	3	1+C2+1+C2+1	3		
	1/3-1/3-1/3	13.303 - 16.675	1+C2+1+C2+1	2	1+C2+1+C2+1	2	1+C2+1+C2+1	2	1+C2+1+C2+1	2	1+C2+1+C2+1	3	1+C2+1+C2+1	3	1+C2+1+C2+1	3		
53-1/8"	1/4-1/2-1/4	12.038 - 14.333	1+C2+1+C2+1	2	1+C2+1+C2+1	2	1+C2+1+C2+1	2	1+C2+1+C2+1	2	1+C2+1+C2+1	3	1+C2+1+C2+1	3	1+C2+1+C2+1	3		
	1/3-1/3-1/3	14.334 - 18.050	1+C2+1+C2+1	2	1+C2+1+C2+1	2	1+C2+1+C2+1	2	1+C2+1+C2+1	2	1+C2+1+C2+1	3	1+C2+1+C2+1	3	1+C2+1+C2+1	3		
61"	1/4-1/2-1/4	12.038 - 16.302	1+C2+1+C2+1	2	1+C2+1+C2+1	2	1+C2+1+C2+1	2	1+C2+1+C2+1	2	1+C2+1+C2+1	3	1+C2+1+C2+1	3	1+C2+1+C2+1	3		
	1/3-1/3-1/3	16.303 - 20.675	1+C2+1+C2+1	2	1+C2+1+C2+1	2	1+C2+1+C2+1	2	1+C2+1+C2+1	2	1+C2+1+C2+1	3	1+C2+1+C2+1	3	1+C2+1+C2+1	3		
76"	1/4-1/2-1/4	12.038 - 20.052	1+C2+2+C2+1	2	1+C2+2+C2+1	2	1+C2+2+C2+1	2	1+C2+2+C2+1	2	1+C2+2+C2+1	3	1+C2+2+C2+1	3	1+C2+2+C2+1	3		
	custom	20.053 - 22.185	1+C2+1+C2+1	2	1+C2+1+C2+1	2	1+C2+1+C2+1	2	1+C2+1+C2+1	2	1+C2+1+C2+1	3	1+C2+1+C2+1	3	1+C2+1+C2+1	3		
	1/3-1/3-1/3	22.186 - 25.675	1+C2+1+C2+1	2	1+C2+1+C2+1	2	1+C2+1+C2+1	2	1+C2+1+C2+1	2	1+C2+1+C2+1	3	1+C2+1+C2+1	3	1+C2+1+C2+1	3		
92-1/8"	1/4-1/2-1/4	** - 24.082	1+C2+3+C2+1	2	1+C2+3+C2+1	2	1+C2+3+C2+1	2	1+C2+3+C2+1	2	1+C2+3+C2+1	3	1+C2+3+C2+1	3	1+C2+3+C2+1	3		
	custom	24.083 - 26.185	1+C2+2+C2+1	2	1+C2+2+C2+1	2	1+C2+2+C2+1	2	1+C2+2+C2+1	2	1+C2+2+C2+1	3	1+C2+2+C2+1	3	1+C2+2+C2+1	3		
	1/3-1/3-1/3	26.186 - 31.038	1+C2+1+C2+1	2	1+C2+1+C2+1	2	1+C2+1+C2+1	2	1+C2+1+C2+1	2	1+C2+1+C2+1	3	1+C2+1+C2+1	3	1+C2+1+C2+1	3		
97"	1/4-1/2-1/4	** - 25.302	1+C2+3+C2+1	2	1+C2+3+C2+1	2	1+C2+3+C2+1	2	1+C2+3+C2+1	2	1+C2+3+C2+1	3	1+C2+3+C2+1	3	1+C2+3+C2+1	3		
	custom	25.303 - 27.185	1+C2+2+C2+1	2	1+C2+2+C2+1	2	1+C2+2+C2+1	2	1+C2+2+C2+1	2	1+C2+2+C2+1	3	1+C2+2+C2+1	3	1+C2+2+C2+1	3		
	custom	27.186 - 31.038	1+C2+2+C2+1	2	1+C2+2+C2+1	2	1+C2+2+C2+1	2	1+C2+2+C2+1	2	1+C2+2+C2+1	3	1+C2+2+C2+1	3	1+C2+2+C2+1	3		
109"	1/4-1/2-1/4	** - 28.302	1+C2+3+C2+1	2	1+C2+3+C2+1	2	1+C2+3+C2+1	2	1+C2+3+C2+1	2	1+C2+3+C2+1	3	1+C2+3+C2+1	3	1+C2+3+C2+1	3		
	custom	28.303 - 29.185	1+C2+3+C2+1	2	1+C2+3+C2+1	2	1+C2+3+C2+1	2	1+C2+3+C2+1	2	1+C2+3+C2+1	3	1+C2+3+C2+1	3	1+C2+3+C2+1	3		
	custom	29.186 - 31.038	1+C2+3+C2+1	2	1+C2+3+C2+1	2	1+C2+3+C2+1	2	1+C2+3+C2+1	2	1+C2+3+C2+1	3	1+C2+3+C2+1	3	1+C2+3+C2+1	3		
120"	1/4-1/2-1/4	** - 31.038	1+C2+3+C2+1	2	1+C2+3+C2+1	2	1+C2+3+C2+1	2	1+C2+3+C2+1	2	1+C2+3+C2+1	3	1+C2+3+C2+1	3	1+C2+3+C2+1	3		

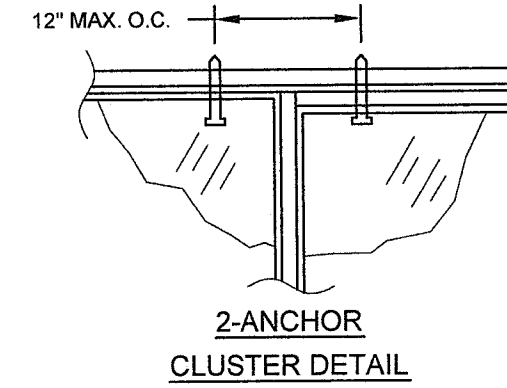

** MIN. SASH WIDTH (FLANGE WINDOWS) = $\frac{\text{OVERALL WIDTH} - 57.924}{2}$

** MIN. SASH WIDTH (EQUAL-LEG WINDOWS) = $\frac{\text{OVERALL WIDTH} - 56.924}{2}$

GUIDE TO USING ANCHOR QUANTITY TABLES FOR XOX WINDOWS:

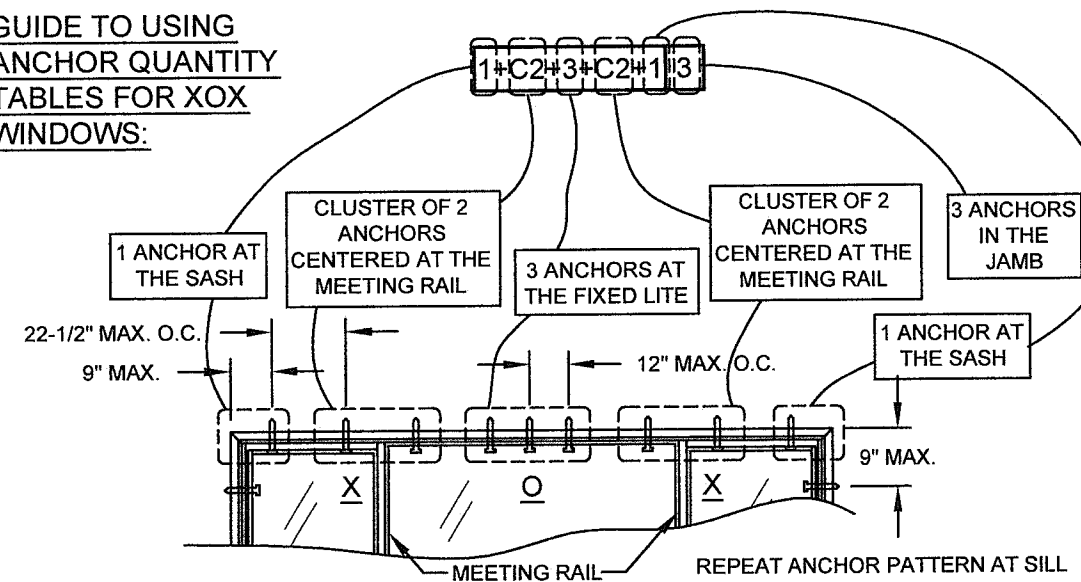

- NOTES:
- OVERALL (TIP TO TIP) DIMENSIONS SHOWN. FOR EQUAL-LEG WINDOWS, SUBTRACT 1" FROM THE TIP TO TIP DIMENSION IN THE TABLE TO DETERMINE THE WINDOW SIZE.
 - FOR SIZES NOT SHOWN, ROUND UP TO THE NEXT AVAILABLE SIZE.

PRODUCT REVISED
 as complying with the Florida Building Code
 NOA-No. **20-0406.04**
 Expiration Date: **08/23/2023**
 By: *Manuel Perez*
 Miami-Dade Product Control

Revision: A) NO CHANGES THIS SHEET.
 JR - 03/11/20

1070 TECHNOLOGY DRIVE N. VENICE, FL 34275 (941) 480-1600	Date	06/30/18	Rev	A
	Drawn By	JENS ROSOWSKI	No.	7710NOA-1
	Series	HR-7710A	Sheet	11 OF 19

REGISTRATION #29296
 ALUMINUM HORIZ. ROLLER INSTALL. (LM)
 ANCHOR QUANTITY TABLES

ANTHONY LYNN MILLER
 LICENSE No. 58705
 9/2/20
 STATE OF FLORIDA
 PROFESSIONAL ENGINEER
 A. LYNN MILLER, P.E.
 P.E.# 58705

TABLE 16:

Overall Width	Sash Configuration	Sash Width Range (in)	Anchor Quantities for XOX Windows											
			Glass Types: 2, 3, 6, 7 Meeting Rail: Standard											
			21-1/8" Overall Hgt.		29" Overall Hgt.		37" Overall Hgt.		49" Overall Hgt.		55" Overall Hgt.		63" Overall Hgt.	
Head & Sill	Jamb	Head & Sill	Jamb	Head & Sill	Jamb	Head & Sill	Jamb	Head & Sill	Jamb	Head & Sill	Jamb			
44"	1/4-1/2-1/4	12.038 - 12.052	1+C2+1+C2+1	2	1+C2+1+C2+1	2	1+C2+1+C2+1	2	1+C2+1+C2+1	3	1+C2+1+C2+1	3	1+C2+1+C2+1	3
	1/3-1/3-1/3	12.053 - 15.008	1+C2+1+C2+1	2	1+C2+1+C2+1	2	1+C2+1+C2+1	2	1+C2+1+C2+1	3	1+C2+1+C2+1	3	1+C2+1+C2+1	3
49"	1/4-1/2-1/4	12.038 - 13.302	1+C2+1+C2+1	2	1+C2+1+C2+1	2	1+C2+1+C2+1	2	1+C2+1+C2+1	3	1+C2+1+C2+1	3	1+C2+1+C2+1	3
	1/3-1/3-1/3	13.303 - 16.675	1+C2+1+C2+1	2	1+C2+1+C2+1	2	1+C2+1+C2+1	2	1+C2+1+C2+1	3	1+C2+1+C2+1	3	1+C2+1+C2+1	3
53-1/8"	1/4-1/2-1/4	12.038 - 14.333	1+C2+1+C2+1	2	1+C2+1+C2+1	2	1+C2+1+C2+1	2	1+C2+1+C2+1	3	1+C2+1+C2+1	3	1+C2+1+C2+1	3
	1/3-1/3-1/3	14.334 - 18.050	1+C2+1+C2+1	2	1+C2+1+C2+1	2	1+C2+1+C2+1	2	1+C2+1+C2+1	3	1+C2+1+C2+1	3	1+C2+1+C2+1	3
61"	1/4-1/2-1/4	12.038 - 16.302	1+C2+1+C2+1	2	1+C2+1+C2+1	2	1+C2+1+C2+1	2	1+C2+1+C2+1	3	1+C2+1+C2+1	3	1+C2+1+C2+1	3
	1/3-1/3-1/3	16.303 - 20.675	1+C2+1+C2+1	2	1+C2+1+C2+1	2	1+C2+1+C2+1	2	1+C2+1+C2+1	3	1+C2+1+C2+1	3	1+C2+1+C2+1	3
76"	1/4-1/2-1/4	12.038 - 20.052	1+C2+2+C2+1	2	1+C2+2+C2+1	2	1+C2+2+C2+1	2	1+C2+2+C2+1	3	1+C2+2+C2+1	3	1+C2+2+C2+1	3
	custom	20.053 - 22.185	1+C2+1+C2+1	2	1+C2+1+C2+1	2	1+C2+1+C2+1	2	1+C2+1+C2+1	3	1+C2+1+C2+1	3	1+C2+1+C2+1	3
	1/3-1/3-1/3	22.186 - 25.675	1+C2+1+C2+1	2	1+C2+1+C2+1	2	1+C2+1+C2+1	2	1+C2+1+C2+1	3	1+C2+1+C2+1	3	1+C2+1+C2+1	3
92-1/8"	1/4-1/2-1/4	** - 24.082	1+C2+3+C2+1	2	1+C2+3+C2+1	2	1+C2+3+C2+1	2	1+C2+3+C2+1	3	1+C2+3+C2+1	3	1+C3+3+C3+1	3
	custom	24.083 - 26.185	1+C2+2+C2+1	2	1+C2+2+C2+1	2	1+C2+2+C2+1	2	1+C2+2+C2+1	3	1+C2+2+C2+1	3	1+C3+2+C3+1	3
	1/3-1/3-1/3	26.186 - 31.048	1+C2+1+C2+1	2	1+C2+2+C2+1	2	1+C2+2+C2+1	2	1+C2+2+C2+1	3	1+C2+2+C2+1	3	1+C3+2+C3+1	3
97"	1/4-1/2-1/4	** - 25.302	1+C2+3+C2+1	2	1+C2+3+C2+1	2	1+C2+3+C2+1	2	1+C2+3+C2+1	3	1+C2+3+C2+1	3	1+C3+3+C3+1	3
	custom	25.303 - 27.185	1+C2+2+C2+1	2	1+C2+2+C2+1	2	1+C2+2+C2+1	2	1+C2+2+C2+1	3	1+C2+2+C2+1	3	1+C3+2+C3+1	3
	1/3-1/3-1/3	27.186 - 32.675	1+C2+1+C2+1	2	1+C2+2+C2+1	2	1+C2+2+C2+1	2	1+C2+2+C2+1	3	1+C2+2+C2+1	3	1+C3+2+C3+1	3
109"	1/4-1/2-1/4	** - 28.302	1+C2+3+C2+1	2	1+C2+3+C2+1	2	1+C2+3+C2+1	2	1+C2+3+C2+1	3	1+C2+3+C2+1	3	1+C3+3+C3+1	3
	custom	28.303 - 30.185	1+C2+3+C2+1	2	1+C2+3+C2+1	2	1+C2+3+C2+1	2	1+C2+3+C2+1	3	1+C2+3+C2+1	3	1+C3+3+C3+1	3
113-5/8"	1/4-1/2-1/4	** - 29.463	1+C2+3+C2+1	2	1+C2+3+C2+1	2	1+C2+3+C2+1	2	1+C2+3+C2+1	3	1+C2+3+C2+1	3	1+C3+3+C3+1	3
	custom	29.464 - 33.185	1+C2+3+C2+1	2	1+C2+3+C2+1	2	1+C2+3+C2+1	2	1+C2+3+C2+1	3	1+C2+3+C2+1	3	1+C3+3+C3+1	3
120"	1/4-1/2-1/4	** - 31.052	1+C2+3+C2+1	2	1+C2+3+C2+1	2	1+C2+3+C2+1	2	1+C2+3+C2+1	3	1+C2+3+C2+1	3	1+C3+3+C3+1	3
	custom	31.053 - 33.185	1+C2+3+C2+1	2	1+C2+3+C2+1	2	1+C2+3+C2+1	2	1+C2+3+C2+1	3	1+C2+3+C2+1	3	1+C3+3+C3+1	3
	custom	33.186 - 38.222	1+C2+2+C2+1	2	1+C2+2+C2+1	2	1+C2+2+C2+1	2	1+C2+2+C2+1	3	1+C2+3+C2+1	3	1+C3+3+C3+1	3

** MIN. SASH WIDTH (FLANGE WINDOWS) = $\frac{\text{OVERALL WIDTH} - 58.556}{2}$

** MIN. SASH WIDTH (EQUAL-LEG WINDOWS) = $\frac{\text{OVERALL WIDTH} - 57.556}{2}$

- NOTES:
- 1) OVERALL (TIP TO TIP) DIMENSIONS SHOWN. FOR EQUAL-LEG WINDOWS, SUBTRACT 1" FROM THE TIP TO TIP DIMENSION IN THE TABLE TO DETERMINE THE WINDOW SIZE.
 - 2) FOR SIZES NOT SHOWN, ROUND UP TO THE NEXT AVAILABLE SIZE.

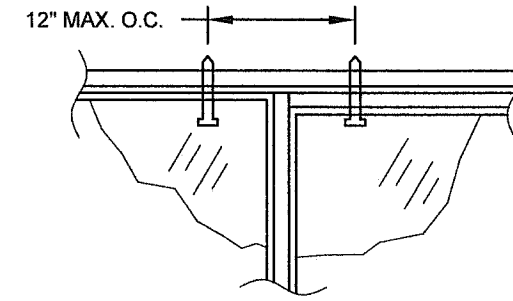

2-ANCHOR CLUSTER DETAIL

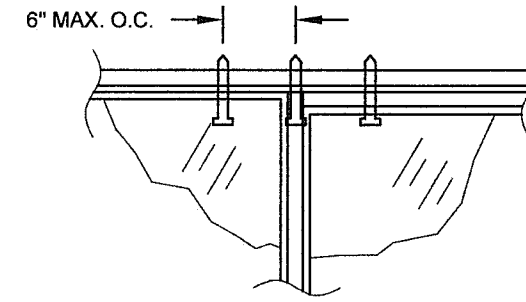

3-ANCHOR CLUSTER DETAIL

GUIDE TO USING ANCHOR QUANTITY TABLES FOR XOX WINDOWS:

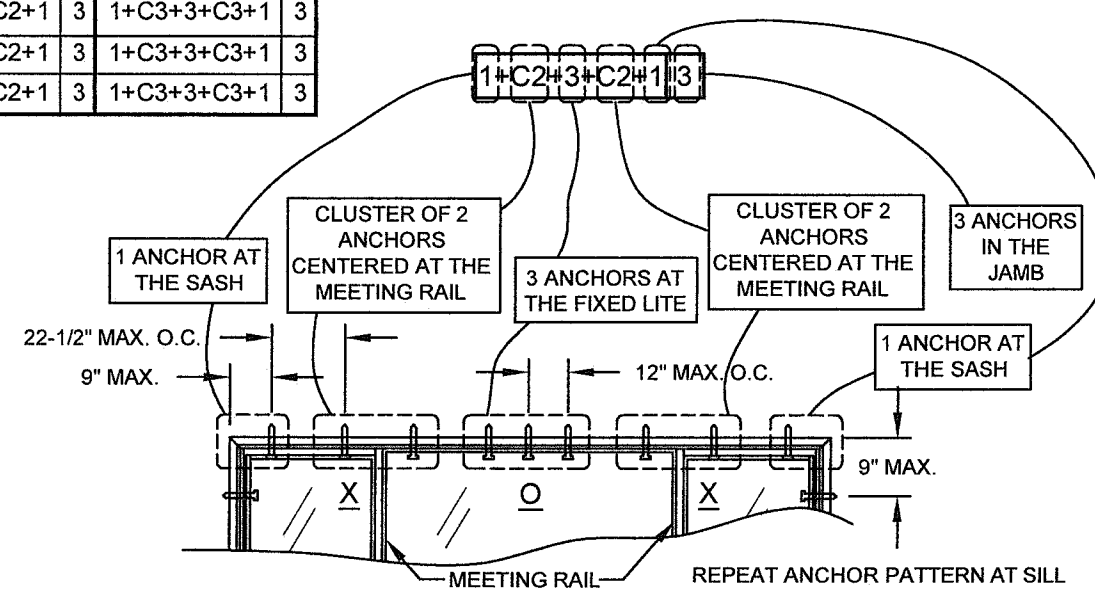

PRODUCT REVISED
as complying with the Florida Building Code
NOA-No. **20-0406.04**
Expiration Date: **08/23/2023**
By: *Manuel Perez*
Miami-Dade Product Control

Revision: A) NO CHANGES THIS SHEET.
JR - 03/11/20

1070 TECHNOLOGY DRIVE
N. VENICE, FL 34275
(941) 480-1600

REGISTRATION #29296

ALUMINUM HORIZ. ROLLER INSTALL. (LM)

ANCHOR QUANTITY TABLES

HR-7710A

12 OF 19

JENS ROSOWSKI

7710NOA-1

06/30/18

Rev. A

ANTHONY LYNN MILLER
LICENSE
No. 58705
4/2/20
STATE OF FLORIDA
PROFESSIONAL ENGINEER
A. LYNN MILLER, P.E.
P.E.# 58705

TABLE 17:

Overall Width	Sash Configuration	Sash Width Range (in)	Anchor Quantities for XOX Windows											
			Glass Types: 8, 10, 11 Meeting Rail: Standard											
			21-1/8" Overall Hgt.		29" Overall Hgt.		37" Overall Hgt.		49" Overall Hgt.		55" Overall Hgt.		63" Overall Hgt.	
Head & Sill	Jamb	Head & Sill	Jamb	Head & Sill	Jamb	Head & Sill	Jamb	Head & Sill	Jamb	Head & Sill	Jamb			
44"	1/4-1/2-1/4	12.038 - 12.052	1+C2+1+C2+1	2	1+C2+1+C2+1	2	1+C2+1+C2+1	2	1+C2+1+C2+1	3	1+C2+1+C2+1	3	1+C2+1+C2+1	3
	1/3-1/3-1/3	12.053 - 15.008	1+C2+1+C2+1	2	1+C2+1+C2+1	2	1+C2+1+C2+1	2	1+C2+1+C2+1	3	1+C2+1+C2+1	3	1+C2+1+C2+1	3
49"	1/4-1/2-1/4	12.038 - 13.302	1+C2+1+C2+1	2	1+C2+1+C2+1	2	1+C2+1+C2+1	2	1+C2+1+C2+1	3	1+C2+1+C2+1	3	1+C2+1+C2+1	3
	1/3-1/3-1/3	13.303 - 16.675	1+C2+1+C2+1	2	1+C2+1+C2+1	2	1+C2+1+C2+1	2	1+C2+1+C2+1	3	1+C2+1+C2+1	3	1+C2+1+C2+1	3
53-1/8"	1/4-1/2-1/4	12.038 - 14.333	1+C2+1+C2+1	2	1+C2+1+C2+1	2	1+C2+1+C2+1	2	1+C2+1+C2+1	3	1+C2+1+C2+1	3	1+C2+1+C2+1	3
	1/3-1/3-1/3	14.334 - 18.050	1+C2+1+C2+1	2	1+C2+1+C2+1	2	1+C2+1+C2+1	2	1+C2+1+C2+1	3	1+C2+1+C2+1	3	1+C2+1+C2+1	3
61"	1/4-1/2-1/4	12.038 - 16.302	1+C2+2+C2+1	2	1+C2+2+C2+1	2	1+C2+2+C2+1	2	1+C2+2+C2+1	3	1+C2+2+C2+1	3	1+C3+2+C3+1	3
	1/3-1/3-1/3	16.303 - 20.675	1+C2+1+C2+1	2	1+C2+1+C2+1	2	1+C2+1+C2+1	2	1+C2+1+C2+1	3	1+C2+1+C2+1	3	1+C3+1+C3+1	3
76"	1/4-1/2-1/4	12.038 - 20.052	1+C2+2+C2+1	2	1+C2+3+C2+1	2	1+C2+3+C2+1	2	1+C2+3+C2+1	3	1+C3+3+C3+1	3	1+C3+3+C3+1	3
	custom	20.053 - 22.185	1+C2+1+C2+1	2	1+C2+2+C2+1	2	1+C2+2+C2+1	2	1+C2+2+C2+1	3	1+C3+2+C3+1	3	1+C3+2+C3+1	3
	1/3-1/3-1/3	22.186 - 25.675	1+C2+1+C2+1	2	1+C2+1+C2+1	2	1+C2+1+C2+1	2	1+C2+1+C2+1	3	1+C3+1+C3+1	3	1+C3+1+C3+1	3
92-1/8"	1/4-1/2-1/4	** - 24.082	1+C2+3+C2+1	2	1+C2+3+C2+1	2	1+C2+3+C2+1	2	1+C2+4+C2+1	3	1+C3+4+C3+1	3	1+C3+3+C3+1	3
	custom	24.083 - 26.185	1+C2+2+C2+1	2	1+C2+2+C2+1	2	1+C2+2+C2+1	2	1+C2+2+C2+1	3	1+C3+2+C3+1	3	1+C3+2+C3+1	3
	1/3-1/3-1/3	26.186 - 31.048	1+C2+2+C2+1	2	1+C2+2+C2+1	2	1+C2+2+C2+1	2	1+C2+2+C2+1	3	1+C3+2+C3+1	3	1+C3+2+C3+1	3
97"	1/4-1/2-1/4	** - 25.302	1+C2+3+C2+1	2	1+C2+3+C2+1	2	1+C2+3+C2+1	2	1+C2+4+C2+1	3	1+C3+4+C3+1	3	1+C3+3+C3+1	3
	custom	25.303 - 27.185	1+C2+2+C2+1	2	1+C2+2+C2+1	2	1+C2+2+C2+1	2	1+C2+3+C2+1	3	1+C3+3+C3+1	3	1+C3+2+C3+1	3
	1/3-1/3-1/3	27.186 - 32.675	1+C2+2+C2+1	2	1+C2+2+C2+1	2	1+C2+2+C2+1	2	1+C2+2+C2+1	3	1+C3+2+C3+1	3	1+C3+2+C3+1	3
109"	1/4-1/2-1/4	** - 28.302	1+C2+3+C2+1	2	1+C2+3+C2+1	2	1+C2+3+C2+1	2	1+C2+4+C2+1	3	1+C3+4+C3+1	3	1+C3+3+C3+1	3
	custom	28.303 - 30.185	1+C2+3+C2+1	2	1+C2+3+C2+1	2	1+C2+3+C2+1	2	1+C2+3+C2+1	3	1+C3+3+C3+1	3	1+C3+3+C3+1	3
113-5/8"	1/4-1/2-1/4	** - 29.463	1+C2+3+C2+1	2	1+C2+3+C2+1	2	1+C2+3+C2+1	2	1+C2+4+C2+1	3	1+C3+4+C3+1	3	1+C3+3+C3+1	3
	custom	29.464 - 33.185	1+C2+3+C2+1	2	1+C2+3+C2+1	2	1+C2+3+C2+1	2	1+C3+3+C3+1	3	1+C3+3+C3+1	3	1+C3+3+C3+1	3
120"	1/4-1/2-1/4	** - 31.052	1+C2+3+C2+1	2	1+C2+3+C2+1	2	1+C2+3+C2+1	2	1+C2+4+C2+1	3	1+C3+4+C3+1	3	1+C3+3+C3+1	3
	custom	31.053 - 33.185	1+C2+3+C2+1	2	1+C2+3+C2+1	2	1+C2+3+C2+1	2	1+C3+4+C3+1	3	1+C3+4+C3+1	3	1+C3+3+C3+1	3
	custom	33.186 - 38.222	2+C2+2+C2+2	2	2+C2+3+C2+2	2	2+C2+3+C2+2	2	2+C3+3+C3+2	3	2+C3+3+C3+2	3	2+C3+3+C3+2	3

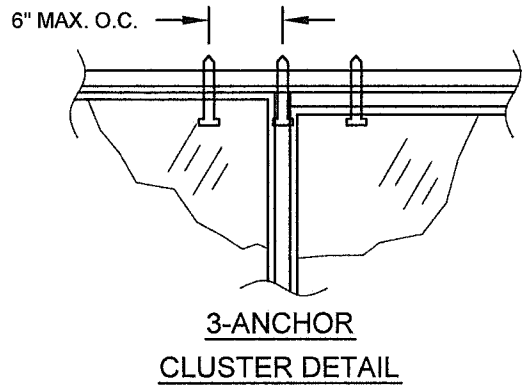
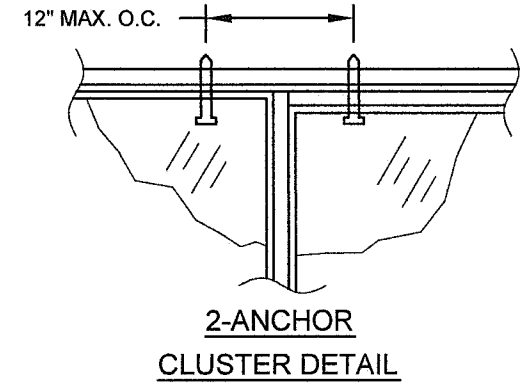

GUIDE TO USING ANCHOR QUANTITY TABLES FOR XOX WINDOWS:

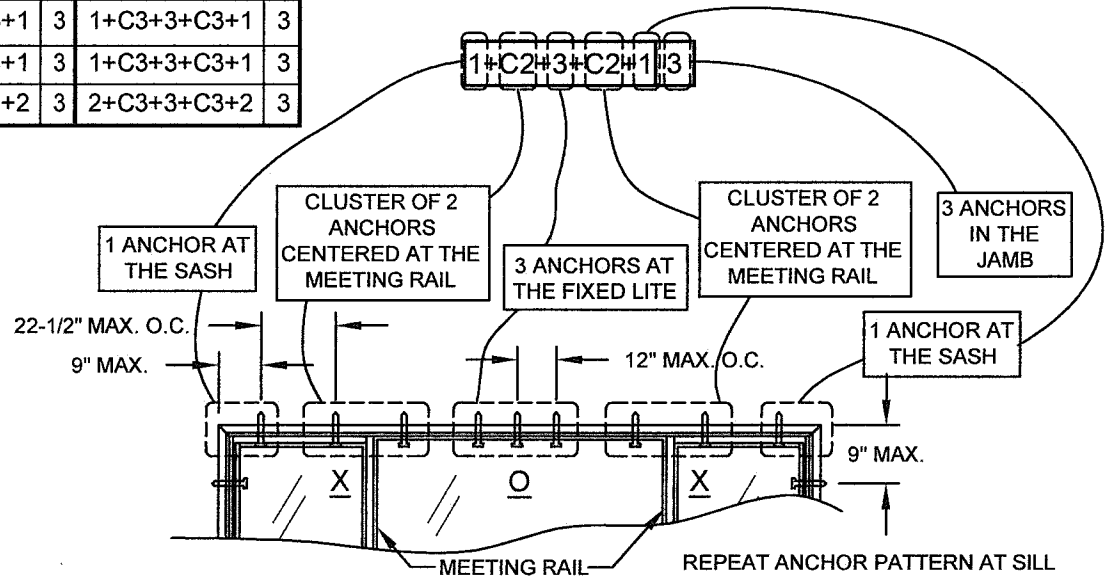

** MIN. SASH WIDTH (FLANGE WINDOWS) = $\frac{\text{OVERALL WIDTH} - 58.556}{2}$
 ** MIN. SASH WIDTH (EQUAL-LEG WINDOWS) = $\frac{\text{OVERALL WIDTH} - 57.556}{2}$

- NOTES:**
- 1) OVERALL (TIP TO TIP) DIMENSIONS SHOWN. FOR EQUAL-LEG WINDOWS, SUBTRACT 1" FROM THE TIP TO TIP DIMENSION IN THE TABLE TO DETERMINE THE WINDOW SIZE.
 - 2) FOR SIZES NOT SHOWN, ROUND UP TO THE NEXT AVAILABLE SIZE.

PRODUCT REVISED
 as complying with the Florida Building Code
NOA-No. 20-0406.04
Expiration Date: 08/23/2023
 By: *Manuel Perez*
 Miami-Dade Product Control

Revision: A) NO CHANGES THIS SHEET.
 JR - 03/11/20

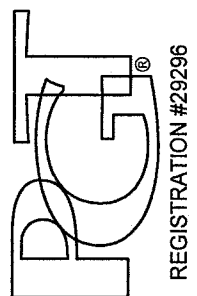
1070 TECHNOLOGY DRIVE N. VENICE, FL 34275 (941) 480-1600	Date	06/30/18	JENS ROSOWSKI	7710NOA-1	A
	Drawn By	JENS ROSOWSKI			
	No.	DWG			
	ALUMINUM HORIZ. ROLLER INSTALL. (LM)		ANCHOR QUANTITY TABLES	13 OF 19	HR-7710A
	REGISTRATION #29296				
Series		Title		Sheet	

ANTHONY LYNN MILLER
 LICENSE
 No. 58705
A 2
4/2/20
 STATE OF FLORIDA
 PROFESSIONAL ENGINEER
 A. LYNN MILLER, P.E.
 P.E.# 58705

TABLE 18:

Overall Width	Sash Configuration	Sash Width Range (in)	Anchor Quantities for XOX Windows											
			Glass Types: 9, 12, 13, 14, 15 Meeting Rail: Standard											
			21-1/8" Overall Hgt.		29" Overall Hgt.		37" Overall Hgt.		49" Overall Hgt.		55" Overall Hgt.		63" Overall Hgt.	
Head & Sill		Jamb	Head & Sill		Jamb	Head & Sill		Jamb	Head & Sill		Jamb	Head & Sill		Jamb
44"	1/4-1/2-1/4	12.038 - 12.052	1+C2+1+C2+1	2	1+C2+1+C2+1	2	1+C2+1+C2+1	2	1+C2+1+C2+1	3	1+C2+1+C2+1	3	1+C2+1+C2+1	3
	1/3-1/3-1/3	12.053 - 15.008	1+C2+1+C2+1	2	1+C2+1+C2+1	2	1+C2+1+C2+1	2	1+C2+1+C2+1	3	1+C2+1+C2+1	3	1+C2+1+C2+1	3
49"	1/4-1/2-1/4	12.038 - 13.302	1+C2+1+C2+1	2	1+C2+1+C2+1	2	1+C2+1+C2+1	2	1+C2+1+C2+1	3	1+C2+1+C2+1	3	1+C2+1+C2+1	3
	1/3-1/3-1/3	13.303 - 16.675	1+C2+1+C2+1	2	1+C2+1+C2+1	2	1+C2+1+C2+1	2	1+C2+1+C2+1	3	1+C2+1+C2+1	3	1+C2+1+C2+1	3
53-1/8"	1/4-1/2-1/4	12.038 - 14.333	1+C2+1+C2+1	2	1+C2+1+C2+1	2	1+C2+1+C2+1	2	1+C2+1+C2+1	3	1+C2+1+C2+1	3	1+C2+1+C2+1	3
	1/3-1/3-1/3	14.334 - 18.050	1+C2+1+C2+1	2	1+C2+1+C2+1	2	1+C2+1+C2+1	2	1+C2+1+C2+1	3	1+C2+1+C2+1	3	1+C2+1+C2+1	3
61"	1/4-1/2-1/4	12.038 - 16.302	1+C2+2+C2+1	2	1+C2+2+C2+1	2	1+C2+2+C2+1	2	1+C2+2+C2+1	3	1+C2+2+C2+1	3	1+C3+2+C3+1	3
	1/3-1/3-1/3	16.303 - 20.675	1+C2+1+C2+1	2	1+C2+1+C2+1	2	1+C2+1+C2+1	2	1+C2+1+C2+1	3	1+C2+1+C2+1	3	1+C3+1+C3+1	3
76"	1/4-1/2-1/4	12.038 - 20.052	1+C2+2+C2+1	2	1+C2+3+C2+1	2	1+C2+3+C2+1	2	1+C2+3+C2+1	3	1+C3+3+C3+1	3	1+C3+3+C3+1	3
	custom	20.053 - 22.185	1+C2+1+C2+1	2	1+C2+2+C2+1	2	1+C2+2+C2+1	2	1+C2+2+C2+1	3	1+C3+2+C3+1	3	1+C3+2+C3+1	3
	1/3-1/3-1/3	22.186 - 25.675	1+C2+1+C2+1	2	1+C2+1+C2+1	2	1+C2+1+C2+1	2	1+C2+1+C2+1	3	1+C3+1+C3+1	3	1+C3+1+C3+1	3
92-1/8"	1/4-1/2-1/4	** - 24.082	1+C2+3+C2+1	2	1+C2+3+C2+1	2	1+C2+3+C2+1	2	1+C2+4+C2+1	3	1+C3+4+C3+1	3	1+C3+4+C3+1	3
	custom	24.083 - 26.185	1+C2+2+C2+1	2	1+C2+2+C2+1	2	1+C2+2+C2+1	2	1+C2+2+C2+1	3	1+C3+2+C3+1	3	1+C3+2+C3+1	3
	1/3-1/3-1/3	26.186 - 31.048	1+C2+2+C2+1	2	1+C2+2+C2+1	2	1+C2+2+C2+1	2	1+C2+2+C2+1	3	1+C3+2+C3+1	3	1+C3+2+C3+1	3
97"	1/4-1/2-1/4	** - 25.302	1+C2+3+C2+1	2	1+C2+3+C2+1	2	1+C2+3+C2+1	2	1+C2+4+C2+1	3	1+C3+4+C3+1	3	1+C3+4+C3+1	3
	custom	25.303 - 27.185	1+C2+2+C2+1	2	1+C2+2+C2+1	2	1+C2+2+C2+1	2	1+C2+3+C2+1	3	1+C3+3+C3+1	3	1+C3+3+C3+1	3
	1/3-1/3-1/3	27.186 - 32.675	1+C2+2+C2+1	2	1+C2+2+C2+1	2	1+C2+2+C2+1	2	1+C2+2+C2+1	3	1+C3+2+C3+1	3	1+C3+2+C3+1	3
109"	1/4-1/2-1/4	** - 28.302	1+C2+3+C2+1	2	1+C2+3+C2+1	2	1+C2+3+C2+1	2	1+C2+4+C2+1	3	1+C3+4+C3+1	3	1+C3+4+C3+1	3
	custom	28.303 - 30.185	1+C2+3+C2+1	2	1+C2+3+C2+1	2	1+C2+3+C2+1	2	1+C2+3+C2+1	3	1+C3+3+C3+1	3	1+C4+3+C4+1	3
113-5/8"	1/4-1/2-1/4	** - 29.463	1+C2+3+C2+1	2	1+C2+3+C2+1	2	1+C2+3+C2+1	2	1+C2+4+C2+1	3	1+C3+4+C3+1	3	1+C4+4+C4+1	3
	1/3-1/3-1/3	33.186 - 38.222	2+C2+2+C2+2	2	2+C2+2+C2+2	2	2+C2+3+C2+2	2	2+C3+3+C3+2	3	2+C3+3+C3+2	3	2+C4+3+C4+2	4
120"	1/4-1/2-1/4	** - 31.052	1+C2+3+C2+1	2	1+C2+3+C2+1	2	1+C2+3+C2+1	2	1+C2+4+C2+1	3	1+C3+4+C3+1	3	1+C4+4+C4+1	3
	custom	31.053 - 33.185	1+C2+3+C2+1	2	1+C2+3+C2+1	2	1+C2+3+C2+1	2	1+C3+4+C3+1	3	1+C3+4+C3+1	3	1+C4+4+C4+1	3
	custom	33.186 - 38.222	2+C2+2+C2+2	2	2+C2+3+C2+2	2	2+C2+3+C2+2	2	2+C3+3+C3+2	3	2+C3+3+C3+2	3	2+C4+3+C4+2	4

** MIN. SASH WIDTH (FLANGE WINDOWS) = $\frac{\text{OVERALL WIDTH} - 58.556}{2}$

** MIN. SASH WIDTH (EQUAL-LEG WINDOWS) = $\frac{\text{OVERALL WIDTH} - 57.556}{2}$

- NOTES:
- OVERALL (TIP TO TIP) DIMENSIONS SHOWN. FOR EQUAL-LEG WINDOWS, SUBTRACT 1" FROM THE TIP TO TIP DIMENSION IN THE TABLE TO DETERMINE THE WINDOW SIZE.
 - FOR SIZES NOT SHOWN, ROUND UP TO THE NEXT AVAILABLE SIZE.

GUIDE TO USING ANCHOR QUANTITY TABLES FOR XOX WINDOWS:

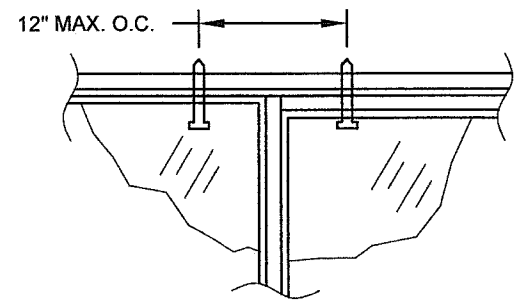
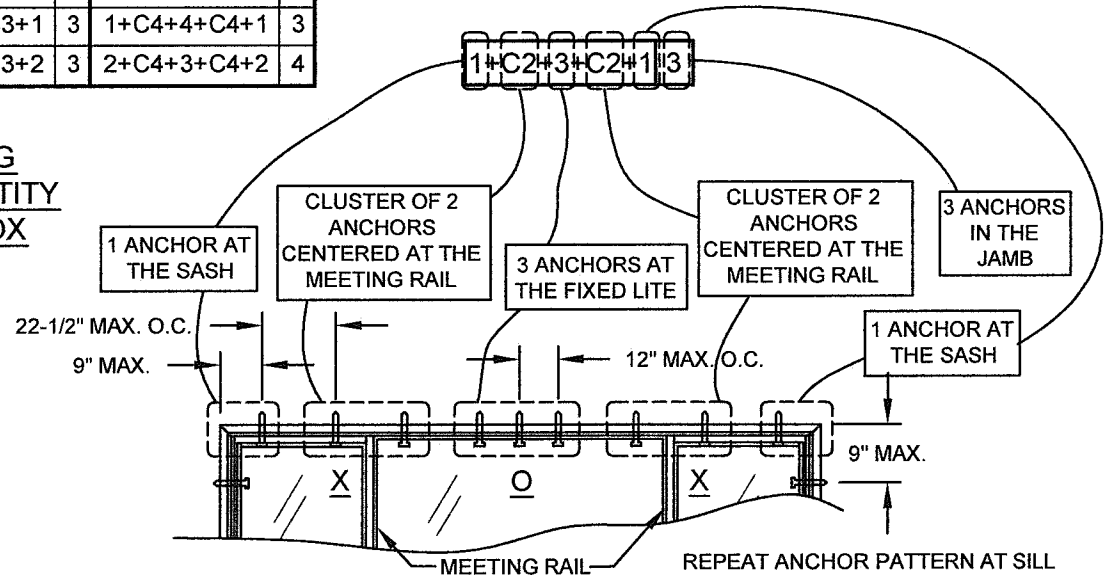

2-ANCHOR CLUSTER DETAIL

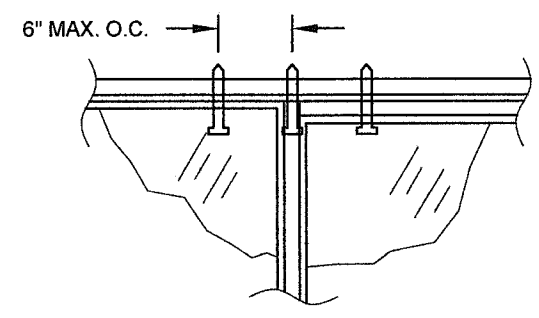

3-ANCHOR CLUSTER DETAIL

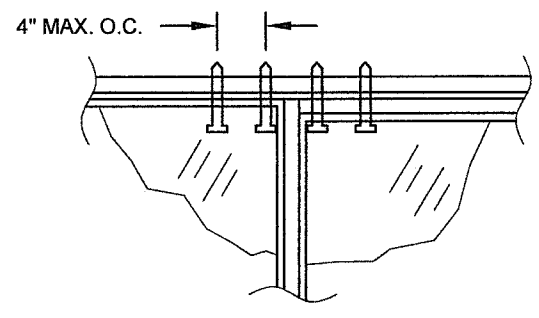

4-ANCHOR CLUSTER DETAIL

PRODUCT REVISED
as complying with the Florida Building Code
NOA-No. **20-0406.04**
Expiration Date: **08/23/2023**
By: *Manuel Perez*
Miami-Dade Product Control

Revision: A) NO CHANGES THIS SHEET.
JR - 03/11/20

1070 TECHNOLOGY DRIVE N. VENICE, FL 34275 (941) 480-1600	Date	06/30/18	JENS ROSOWSKI	7710NOA-1	A
	By				
REGISTRATION #29296	ALUMINUM HORIZ. ROLLER INSTALL. (LM)		ANCHOR QUANTITY TABLES	HR-7710A	14 OF 19
	Series Desc. Title				

ANTHONY LYNN MILLER
LICENSE
No. 58705
4/2/20
STATE OF FLORIDA
PROFESSIONAL ENGINEER
A. LYNN MILLER, P.E.
P.E.# 58705

INSTALLATION OPTION 1
 ANCHORED THROUGH FRAME INTO 2X WOOD FRAME
 OR BUCKSTRIP. SEE NOTE 2, THIS SHEET.

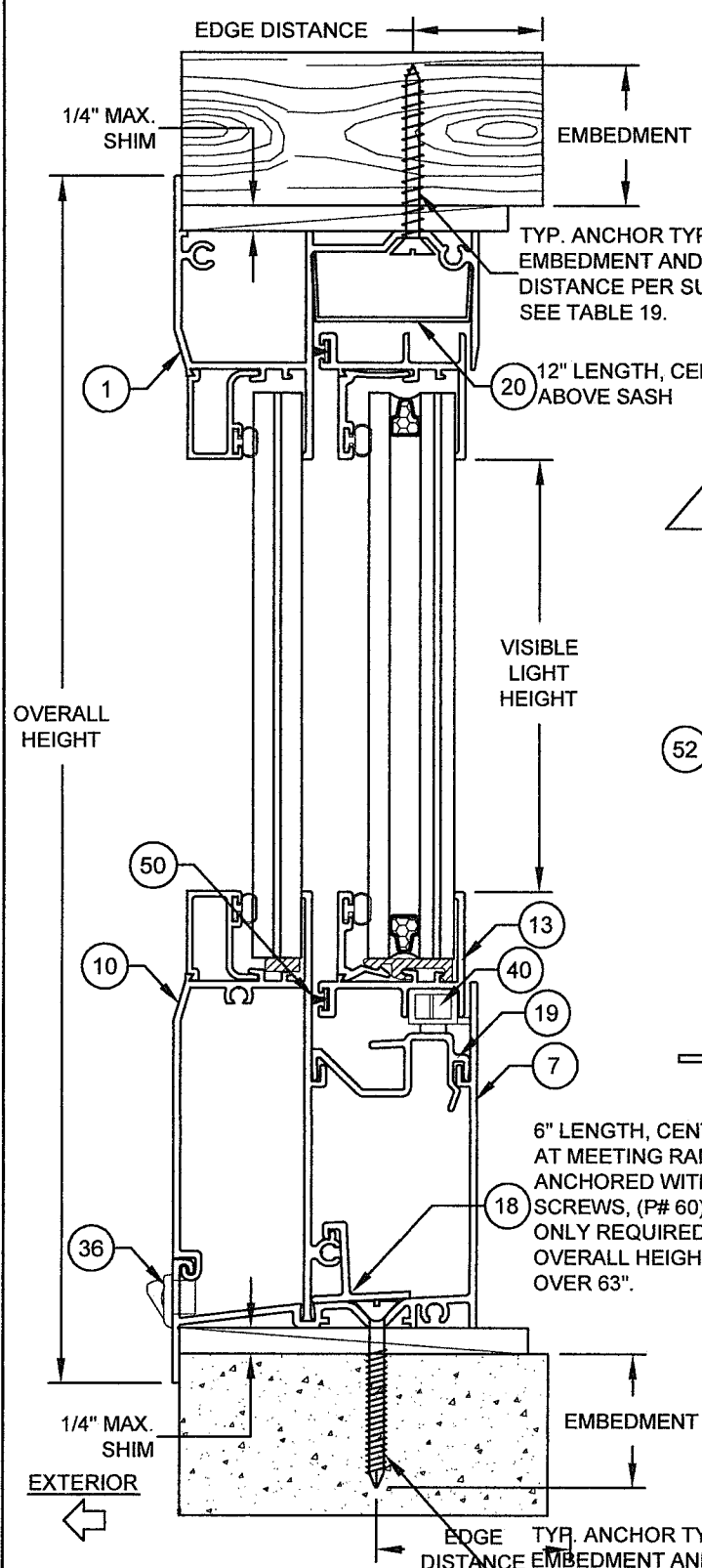

INSTALLATION OPTION 2
 ANCHORED THROUGH FRAME
 DIRECTLY INTO CONCRETE/CMU.
VERTICAL SECTION B-B

INSTALLATION OPTION 2
 ANCHORED THROUGH FRAME
 DIRECTLY INTO CONCRETE/CMU.

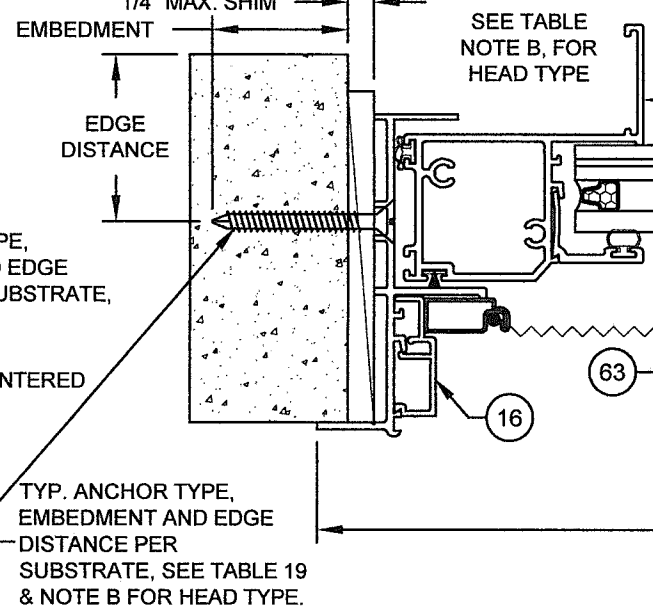

HORIZONTAL SECTION A-A
 (SHOWN WITH I.G. GLAZING)

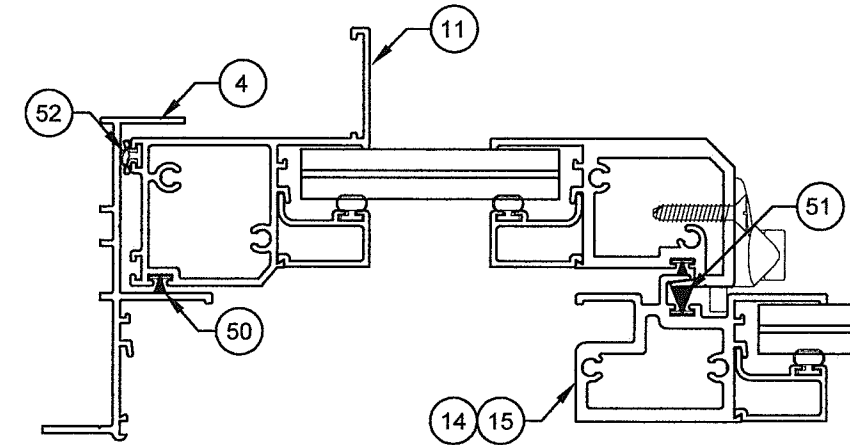

HORIZONTAL SECTION C-C
 (SHOWN WITH MONO. GLAZING)

INSTALLATION OPTION 3
 ANCHORED THROUGH FRAME AND 1X BUCKSTRIP
 INTO CONCRETE/CMU. SEE NOTE 2, THIS SHEET.

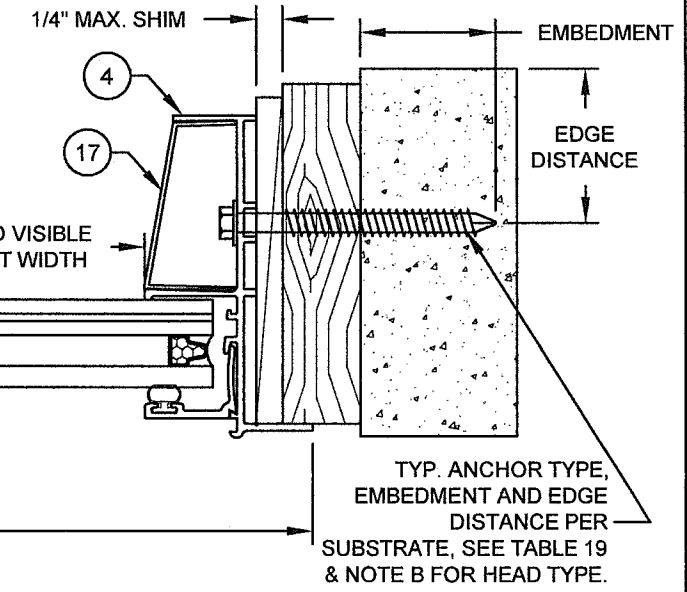

TYP. ANCHOR TYPE,
 EMBEDMENT AND EDGE
 DISTANCE PER
 SUBSTRATE, SEE TABLE 19
 & NOTE B FOR HEAD TYPE.

**INSTALLATION
 OPTION 4**
 ANCHORED THROUGH
 FRAME INTO METAL

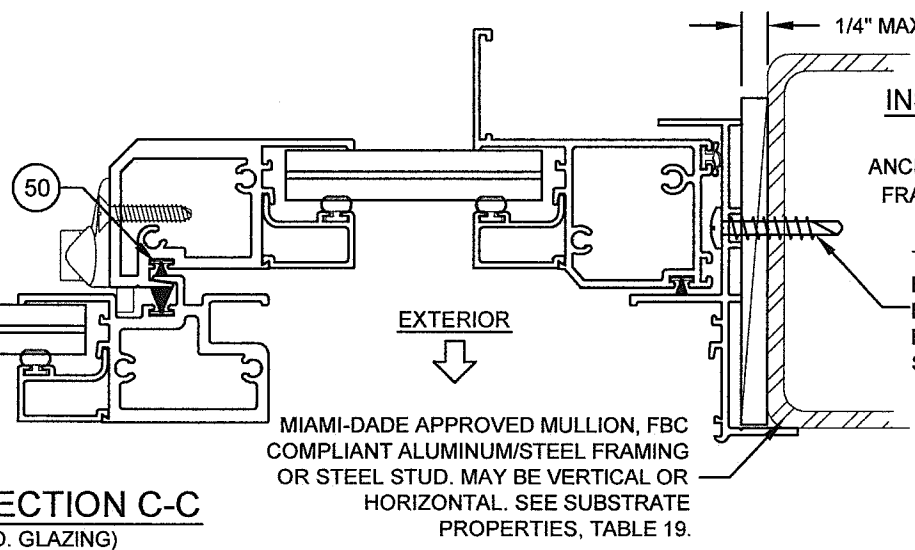

TYP. ANCHOR TYPE,
 EMBEDMENT AND
 EDGE DISTANCE
 PER SUBSTRATE,
 SEE TABLE 19.

MIAMI-DADE APPROVED MULLION, FBC
 COMPLIANT ALUMINUM/STEEL FRAMING
 OR STEEL STUD. MAY BE VERTICAL OR
 HORIZONTAL. SEE SUBSTRATE
 PROPERTIES, TABLE 19.

NOTES:

- 1) USE ONLY SUBSTRATE-APPROPRIATE ANCHORS LISTED ON TABLE 19. FOLLOW EMBEDMENT AND EDGE DISTANCE LIMITS. ANY INSTALLATION OPTION SHOWN MAY BE USED ON ANY SIDE OF THE WINDOW.
- 2) MASONRY ANCHORS MAY BE USED INTO WOOD AS PER TABLE 19. ALL WOOD BUCKS LESS THAN 1-1/2" THICK ARE TO BE CONSIDERED 1X INSTALLATIONS. 1X WOOD BUCKS ARE OPTIONAL IF UNIT IS INSTALLED DIRECTLY TO SUBSTRATE. WOOD BUCKS DEPICTED AS 2X ARE 1-1/2" THICK OR GREATER. 1X AND 2X BUCKS (WHEN USED) SHALL BE DESIGNED TO PROPERLY TRANSFER LOADS TO THE STRUCTURE. WOOD BUCK DESIGN AND INSTALLATION IS THE RESPONSIBILITY OF THE ENGINEER OR ARCHITECT OF RECORD.
- 3) VISIBLE LIGHT WIDTH OR HEIGHT (ALSO REFERRED TO AS DAYLIGHT OPENING) IS MEASURED FROM BEADING TO BEADING.

TABLE 19:

Anchor	Substrate	Min. Edge Distance	Min. Embedment
#12 Steel, 18-8 or 410 SS Screw	Southern Pine (SG=0.55)	9/16"	1-3/8"
	Aluminum, 6063-T5 min.	3/8"	0.063"
	A36 Steel	3/8"	0.063"
	Steel Stud, Gr. 33 min.	3/8"	0.045" (18 Ga)
1/4" 410 SS CreteFlex	Concrete (min. 3.35 ksi)	1"	1-3/4"
	UngROUTED CMU, (ASTM C-90)	2-1/2"	1-1/4"
	Southern Pine (SG=0.55)	1"	1-3/8"
1/4" Steel Ultracon	Concrete (min. 2.85 ksi)	1"	1-3/8"
	UngROUTED CMU, (ASTM C-90)	2-1/2"	1-1/4"
	Southern Pine (SG=0.55)	1"	1-3/8"
1/4" Steel Ultracon +	Concrete (min. 3.00 ksi)	1-3/16"	1-3/8"
	UngROUTED CMU, (ASTM C-90)	1-1/2"	1-1/4"
	Southern Pine (SG=0.55)	1"	1-3/8"

A) MIN. OF 3 THREADS BEYOND THE METAL SUBSTRATE.

B) USE ONLY FLATHEAD ANCHORS IN HEAD AND SILL. PAN/HEX/FLAT HEAD TYPE IS ALLOWABLE FOR ANCHORS IN THE JAMBS.

C) "UNGROUTED CMU" VALUES MAY BE USED FOR GROUTED CMU APPLICATIONS.

PRODUCT REVISED
 as complying with the Florida Building Code
NOA-No. 20-0406.04
 Expiration Date: **08/23/2023**
 By: *Manuel Perez*
 Miami-Dade Product Control

Revision: A) REVISED ANCHOR TYPE TABLE.
 JR - 03/11/20

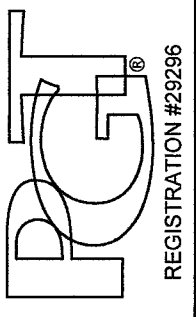
1070 TECHNOLOGY DRIVE N. VENICE, FL 34275 (941) 480-1600	Date	06/30/18	JENS ROSOWSKI	7710NOA-1	A
	Drawn By				
	DWG No.				
 REGISTRATION #29296 ALUMINUM HORIZ. ROLLER INSTALL. (LM) INSTALLATION, FLANGE	Sheet	15 OF 19	HR-7710A		
	Series				
	Title				

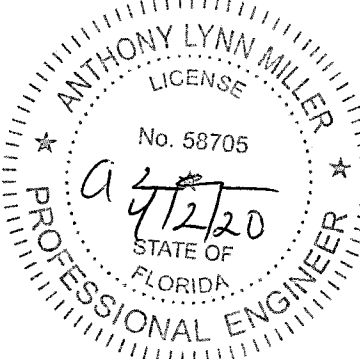
 ANTHONY LYNN MILLER
 LICENSE
 No. 58705
 STATE OF FLORIDA
 PROFESSIONAL ENGINEER
 A. LYNN MILLER, P.E.
 P.E.# 58705

INSTALLATION OPTION 1

ANCHORED THROUGH FRAME INTO 2X WOOD FRAME OR BUCKSTRIP. SEE NOTE 2, THIS SHEET.

INSTALLATION OPTION 2

ANCHORED THROUGH FRAME DIRECTLY INTO CONCRETE/CMU.

INSTALLATION OPTION 3

ANCHORED THROUGH FRAME AND 1X BUCKSTRIP INTO CONCRETE/CMU. SEE NOTE 2, THIS SHEET.

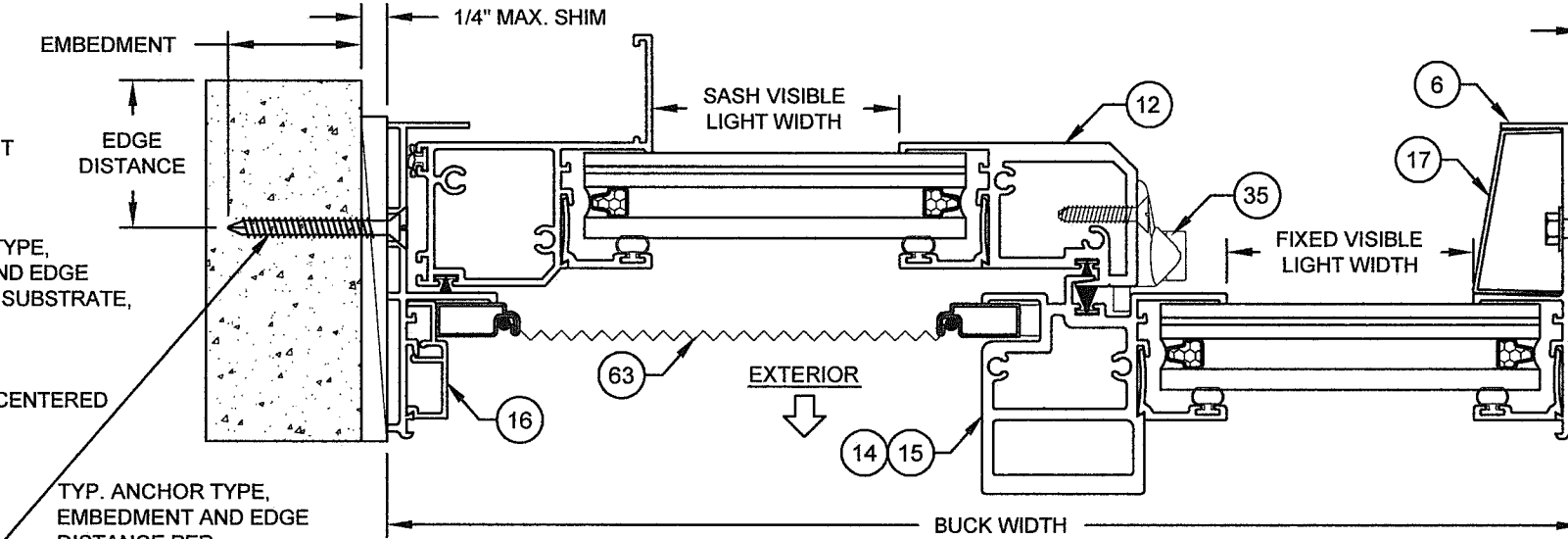
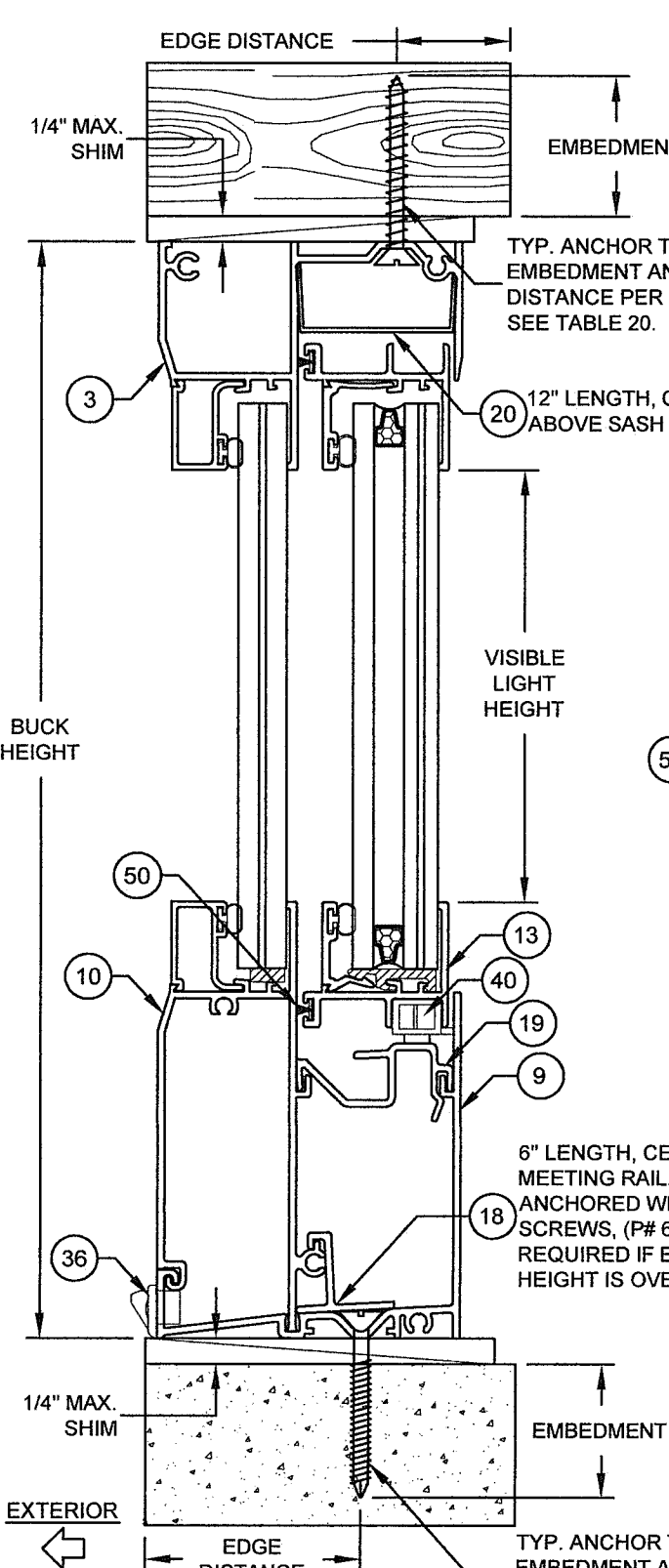

HORIZONTAL SECTION A-A
(SHOWN WITH I.G. GLAZING)

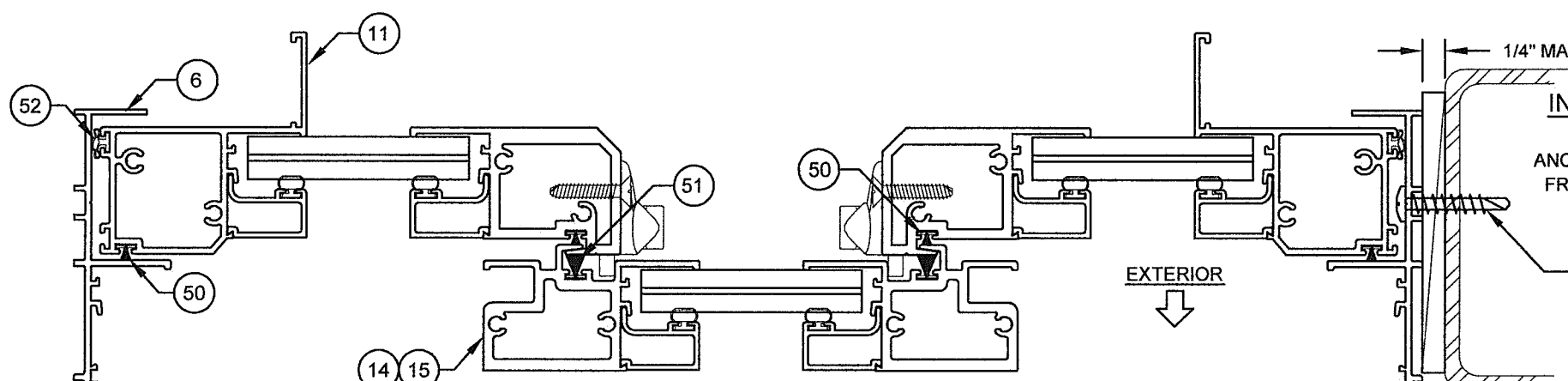

HORIZONTAL SECTION C-C
(SHOWN WITH MONO. GLAZING)



VERTICAL SECTION B-B

NOTES:

- 1) USE ONLY SUBSTRATE-APPROPRIATE ANCHORS LISTED ON TABLE 20. FOLLOW EMBEDMENT AND EDGE DISTANCE LIMITS. ANY INSTALLATION OPTION SHOWN MAY BE USED ON ANY SIDE OF THE WINDOW.
- 2) MASONRY ANCHORS MAY BE USED INTO WOOD AS PER TABLE 20. ALL WOOD BUCKS LESS THAN 1-1/2" THICK ARE TO BE CONSIDERED 1X INSTALLATIONS. 1X WOOD BUCKS ARE OPTIONAL IF UNIT IS INSTALLED DIRECTLY TO SUBSTRATE. WOOD BUCKS DEPICTED AS 2X ARE 1-1/2" THICK OR GREATER. 1X AND 2X BUCKS (WHEN USED) SHALL BE DESIGNED TO PROPERLY TRANSFER LOADS TO THE STRUCTURE. WOOD BUCK DESIGN AND INSTALLATION IS THE RESPONSIBILITY OF THE ENGINEER OR ARCHITECT OF RECORD.
- 3) VISIBLE LIGHT WIDTH OR HEIGHT (ALSO REFERRED TO AS DAYLIGHT OPENING) IS MEASURED FROM BEADING TO BEADING.

TABLE 20:

Anchor	Substrate	Min. Edge Distance	Min. Embedment
#12 Steel, 18-8 or 410 SS Screw	Southern Pine (SG=0.55)	9/16"	1-3/8"
	Aluminum, 6063-T5 min.	3/8"	0.063"
	A36 Steel	3/8"	0.063"
1/4" 410 SS CreteFlex	Concrete (min. 3.35 ksi)	1"	1-3/4"
	UngROUTED CMU, (ASTM C-90)	2-1/2"	1-1/4"
	Southern Pine (SG=0.55)	1"	1-3/8"
1/4" Steel Ultracon	Concrete (min. 2.85 ksi)	1"	1-3/8"
	UngROUTED CMU, (ASTM C-90)	2-1/2"	1-1/4"
	Southern Pine (SG=0.55)	1"	1-3/8"
1/4" Steel Ultracon +	Concrete (min. 3.00 ksi)	1-3/16"	1-3/8"
	UngROUTED CMU, (ASTM C-90)	1-1/2"	1-1/4"
	Southern Pine (SG=0.55)	1"	1-3/8"

- A) MIN. OF 3 THREADS BEYOND THE METAL SUBSTRATE.
- B) USE ONLY FLATHEAD ANCHORS IN HEAD AND SILL. PAN/HEX/FLAT HEAD TYPE IS ALLOWABLE FOR ANCHORS IN THE JAMBS.
- C) "UNGRouted CMU" VALUES MAY BE USED FOR GRouted CMU APPLICATIONS.

PRODUCT REVISED
as complying with the Florida Building Code
NOA-No. **20-0406.04**
Expiration Date: **08/23/2023**
By: *Manuel Perez*
Miami-Dade Product Control

Revision: A) REVISED ANCHOR TYPE TABLE.
JR - 03/11/20

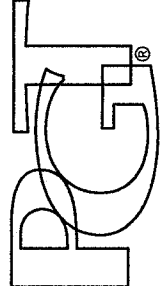
1070 TECHNOLOGY DRIVE N. VENICE, FL 34275 (941) 480-1600	Date	06/30/18	JENS ROSOWSKI	A
	Drawn By	JENS ROSOWSKI		
	No.	7710NOA-1		
	DWG	16 OF 19		
 REGISTRATION #29296 ALUMINUM HORIZ. ROLLER INSTALL. (LM) INSTALLATION, EQUAL-LEG	Sheet	HR-7710A	Series	
	Title			

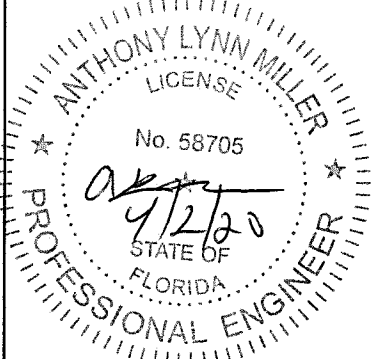

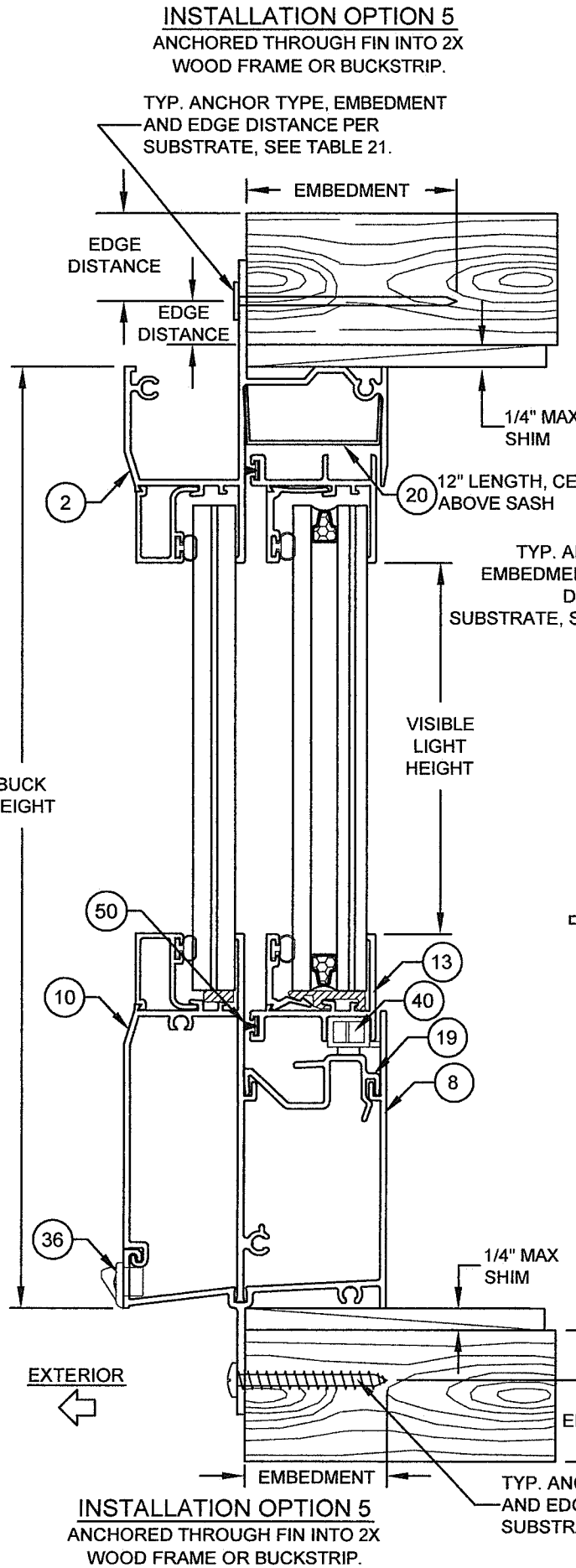
 ANTHONY LYNN MILLER
 LICENSE
 No. 58705
 STATE OF FLORIDA
 PROFESSIONAL ENGINEER
 A. LYNN MILLER, P.E.
 P.E.# 58705

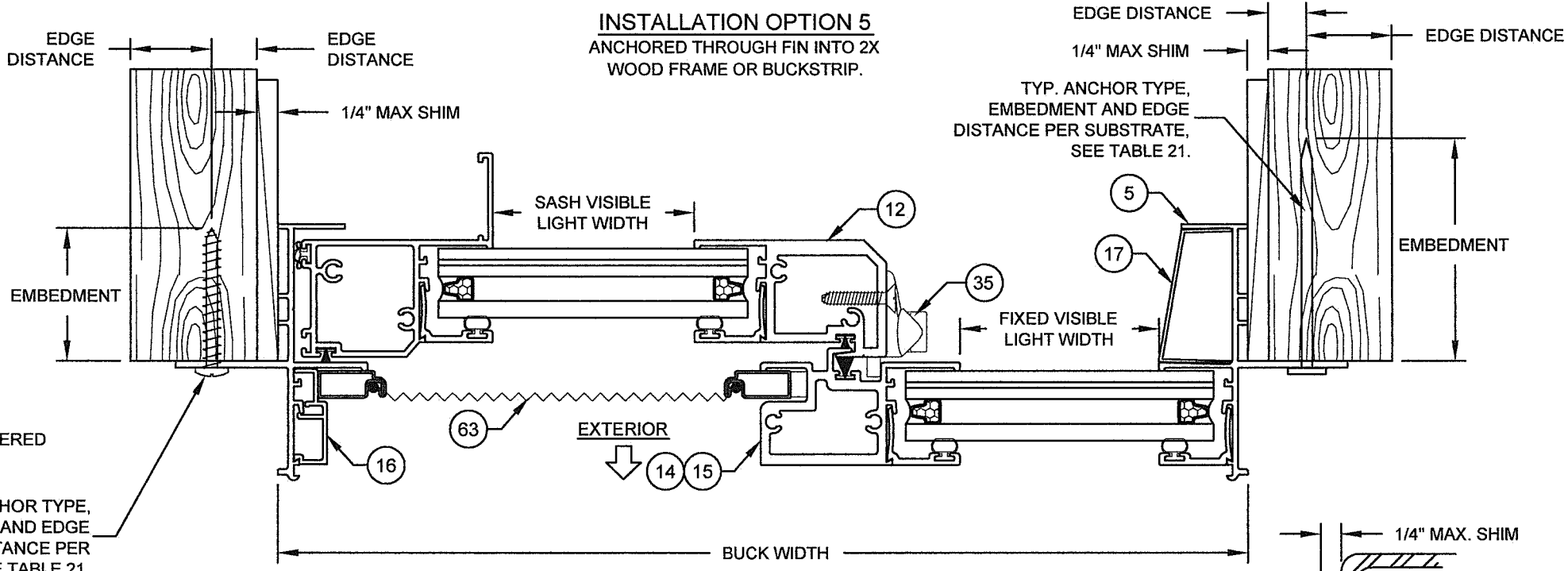

VERTICAL SECTION B-B

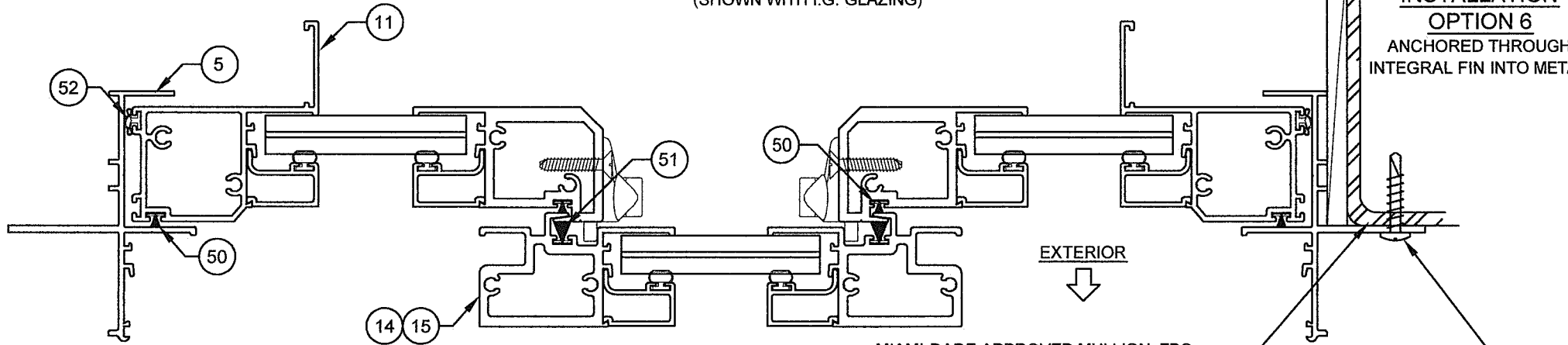

HORIZONTAL SECTION A-A
(SHOWN WITH I.G. GLAZING)



HORIZONTAL SECTION C-C
(SHOWN WITH MONO. GLAZING)

- NOTES:**
- 1) USE ONLY SUBSTRATE-APPROPRIATE ANCHORS LISTED ON TABLE 21. FOLLOW EMBEDMENT AND EDGE DISTANCE LIMITS. ANY INSTALLATION OPTION SHOWN MAY BE USED ON ANY SIDE OF THE WINDOW.
 - 2) VISIBLE LIGHT WIDTH OR HEIGHT (ALSO REFERRED TO AS DAYLIGHT OPENING) IS MEASURED FROM BEADING TO BEADING.
 - 3) ANCHOR TO BE INSTALLED WITHIN 2-1/2" OF FIN CORNER.

TABLE 21:

Anchor	Substrate	Min. Edge Distance	Max. O.C.	Min. Embedment
2-1/2" x .113" Box Nail	Southern Pine (SG=0.55)	5/16"	5"	2-7/16"
2-1/2" x .131" Common Nail	Southern Pine (SG=0.55)	3/8"	5"	2-7/16"
2-1/2" x .145" Roofing Nail	Southern Pine (SG=0.55)	3/8"	5"	2-7/16"
2-1/2" x .145" Roofing Nail	Southern Pine (SG=0.55)	3/8"	5"	2-7/16"
#10 Steel Trusshead Screw or #12 Steel, 18-8 or 410 SS Screw	Southern Pine (SG=0.55)	1/2"	5"	1-3/8"
	0.125" Aluminum, 6063-T5 min.	5/16"	5"	0.09"
	0.050" A36 Steel	5/16"	5"	0.050"
	0.045" (18 Ga) Steel Stud, Gr. 33 min.	5/16"	5"	0.045"

1) MIN. OF 3 THREADS BEYOND THE METAL SUBSTRATE.

PRODUCT REVISED
as complying with the Florida Building Code
NOA-No. **20-0406.04**
Expiration Date: **08/23/2023**
By: *Manuel Ferrer*
Miami-Dade Product Control

Revision: A) NO CHANGES THIS SHEET.
JR - 03/11/20

1070 TECHNOLOGY DRIVE
N. VENICE, FL 34275
(941) 480-1600

REGISTRATION #29296

ALUMINUM HORIZ. ROLLER INSTALL. (LM) 06/30/18
JENS ROSOWSKI
INSTALLATION, INTEGRAL FIN
HR-7710A 17 OF 19
7710NOA-1 A

ANTHONY LYNN MILLER
LICENSE
No. 58705
4/2/20
STATE OF FLORIDA
PROFESSIONAL ENGINEER
A. LYNN MILLER, P.E.
P.E.# 58705

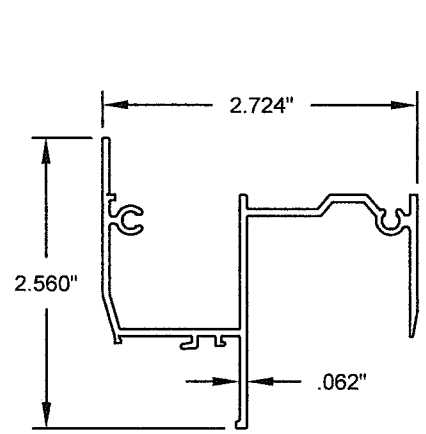

① HEAD, FLANGE FRAME

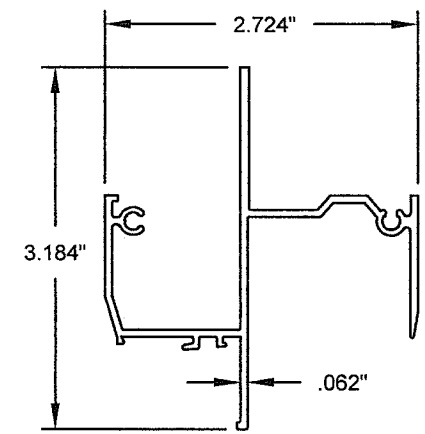

② HEAD, INTEGRAL FIN FRAME

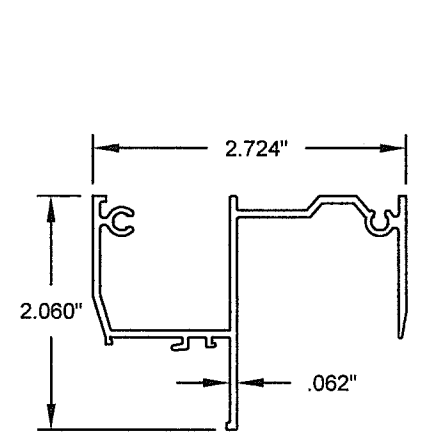

③ HEAD, EQUAL LEG FRAME

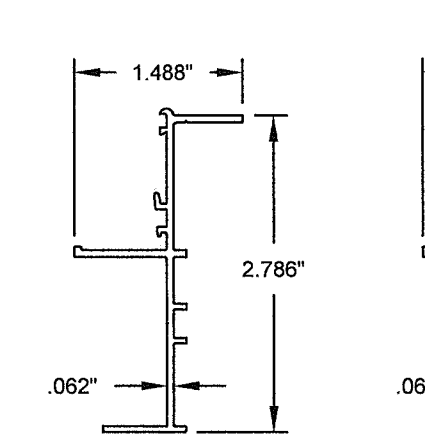

④ JAMB, FLANGE FRAME

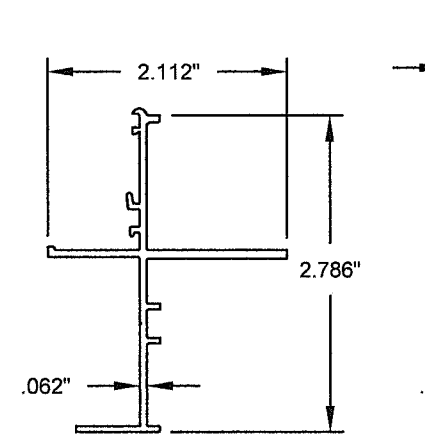

⑤ JAMB, INTEGRAL FIN FRAME

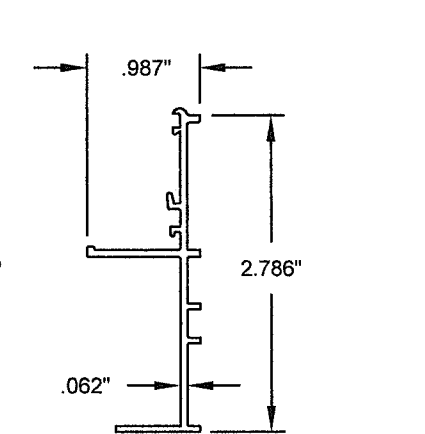

⑥ JAMB, EQUAL LEG FRAME

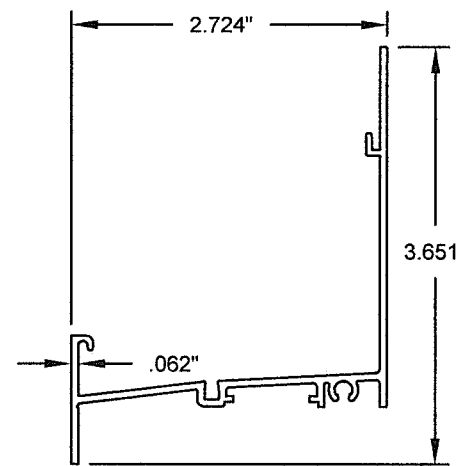

⑦ SILL, FLANGE FRAME

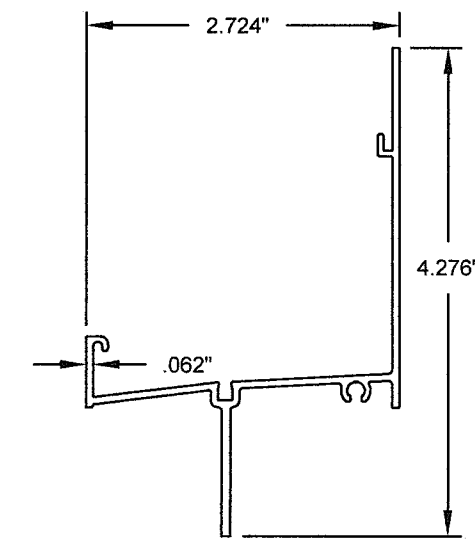

⑧ SILL, INTEGRAL FIN FRAME

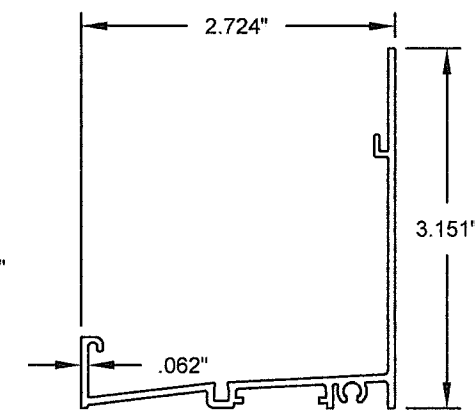

⑨ SILL, EQUAL LEG FRAME

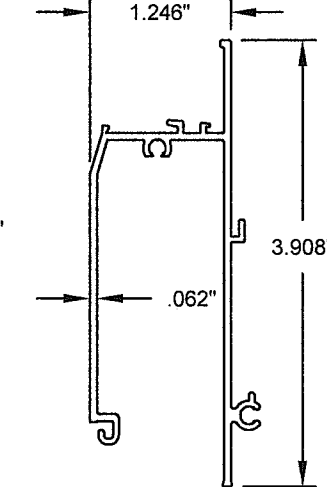

⑩ SILL ADAPTER

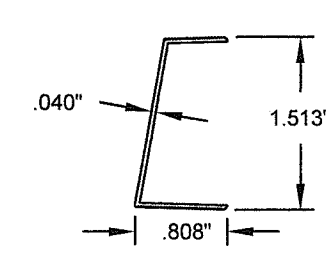

⑪ INSTALLATION HOLE COVER

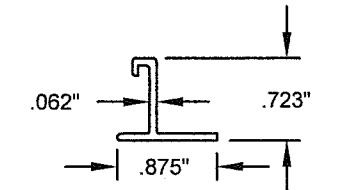

⑫ WINDLOAD ADAPTER

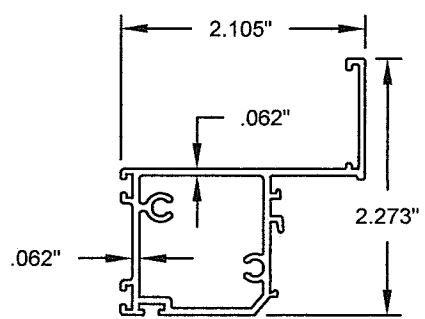

⑬ SASH PULL RAIL

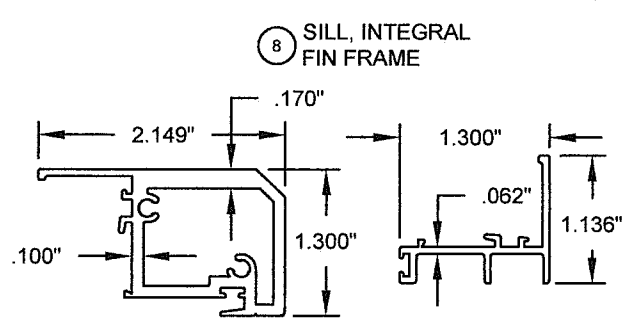

⑭ SASH LOCK RAIL

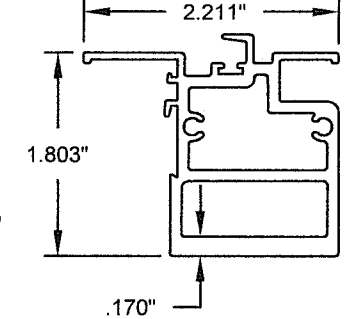

⑮ SASH TOP & BOTTOM RAIL

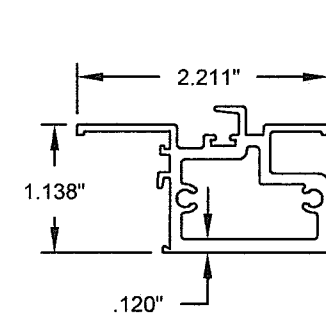

⑯ HD MEETING RAIL

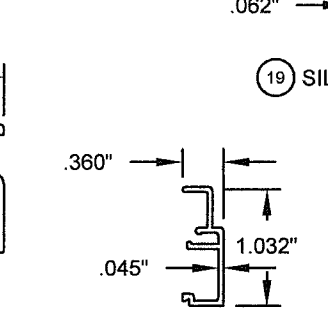

⑰ STD MEETING RAIL

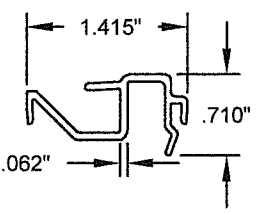

⑱ SILL TRACK

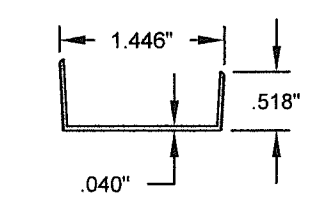

⑲ ANTI-LIFT CLIP

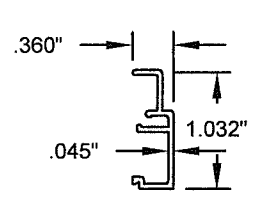

⑳ SCREEN ADAPTER

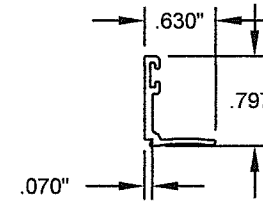

㉑ IG BEAD

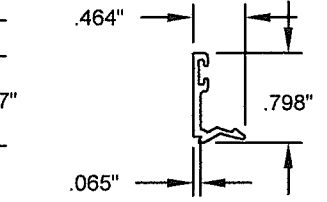

㉒ IG SNAP BEAD

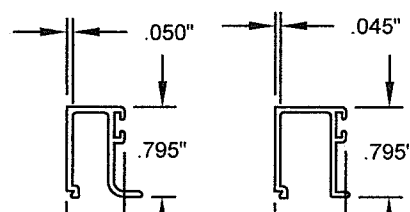

㉓ 7/16" BEAD

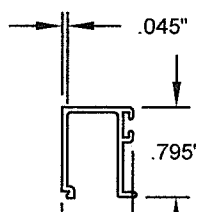

㉔ 5/16" BEAD

TABLE 22: MATERIAL PROPERTIES USED FOR ANCHORAGE CALCULATIONS:

Material	Min. F _y	Min. F _u
Steel Screw	92 ksi	120 ksi
18-8 Screw	60 ksi	95 ksi
410 Screw	90 ksi	110 ksi
Elco UltraCon®	155 ksi	177 ksi
1/4" DeWalt UltraCon+®	148 ksi	164 ksi
410 SS DeWalt/Elco CreteFlex®	127.4 ksi	189.7 ksi
6063-T5 Aluminum	16 ksi	22 ksi
A36 Steel	36 ksi	58 ksi
Gr. 33 Steel Stud	33 ksi	45 ksi

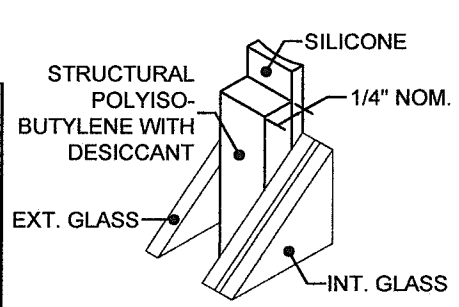

㉕ KODISPACE 4SG TPS

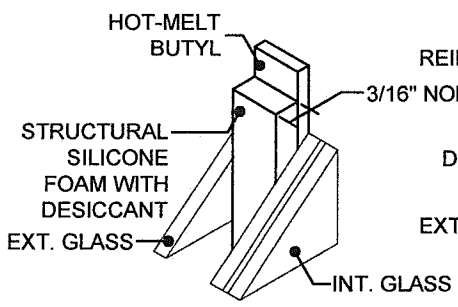

㉖ SUPER SPACER[®] NXT[™]

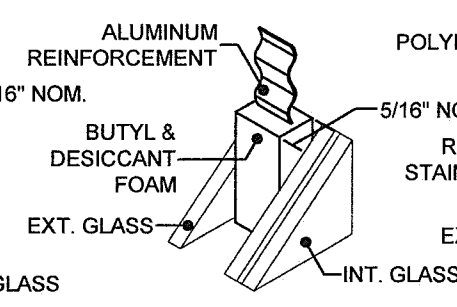

㉗ DURASEAL[®] SPACER

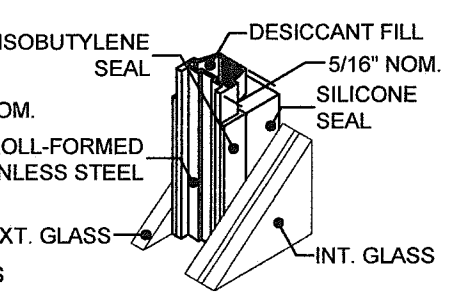

㉘ XL EDGE[™] SPACER

PRODUCT REVISED
as complying with the Florida Building Code
NOA-No. **20-0406.04**
Expiration Date: **08/23/2023**
By: *Manuel Perez*
Miami-Dade Product Control

Revision: A) UPDATED MATERIAL PROP. TABLE.
JR - 03/11/20

1070 TECHNOLOGY DRIVE N. VENICE, FL 34275 (941) 480-1600	Date	06/30/18	Rev.	A
	Drawn By	JENS ROSOWSKI	Sheet	18 OF 19
ALUMINUM HORIZ. ROLLER INSTALL. (LM)	No.	7710NOA-1	Series	
EXTRUSIONS	Desc. Title	HR-7710A	Title	

ANTHONY LYNN MILLER
LICENSE
No. 58705
9/2/20
STATE OF FLORIDA
PROFESSIONAL ENGINEER
A. LYNN MILLER, P.E.
P.E.# 58705

TABLE 23:

Item #	Part #	Description	Material
1	624038	Head, Flange Frame	Alum. 6063-T6
2	624039	Head, Integral Fin Frame	Alum. 6063-T6
3	624040	Head, Equal-leg Frame	Alum. 6063-T6
4	624001	Jamb, Flange Frame	Alum. 6063-T6
5	624017	Jamb, Integral Fin Frame	Alum. 6063-T6
6	624028	Jamb, Equal-leg Frame	Alum. 6063-T6
7	624035	Sill, Flange Frame	Alum. 6063-T6
8	624036	Sill, Integral Fin Frame	Alum. 6063-T6
9	624037	Sill, Equal-leg Frame	Alum. 6063-T6
10	624034	Sill Adaptor	Alum. 6063-T6
11	624043	Sash Pull Rail	Alum. 6063-T6
12	624006	Sash Lock Rail	Alum. 6005A-T61
13	624041	Sash Top & Bottom Rail	Alum. 6063-T6
14	624027	HD Meeting Rail	Alum. 6063-T6
15	624005	Std. Meeting Rail	Alum. 6005A-T61
16	624047	Screen Adapter	Alum. 6063-T6
17	624051	Installation Hole Cover	Alum. 6063-T6
18	64125M	Windload Adapter	Alum. 6063-T6
19	624042	Sill Track	Alum. 6063-T6
20	624015	Anti-Lift Clip	Alum. 6063-T6
21A	624009	IG Bead	Alum. 6063-T5
21B	624011	IG Snap Bead	Alum. 6063-T5
23	624026	7/16" Lami Glaz. Bead	Alum. 6063-T6
24	624013	5/16" Lami Glaz. Bead	Alum. 6063-T6
30	6TP247	Glazing Bead, Bulb Vinyl for #624013 & #624026	Vinyl
31	6TP248	Glazing Bead, Bulb Vinyl for #624009 & #624011	Vinyl
32	712653K	Mono setting Block 3/32" X 1/4" X 1"	Neoprene
33A	71715K	Lami IG Setting Block 1/8" x 3/4" x 1-1/14"	Neoprene
33B	624014	IG Snap Setting Block	Vinyl
35	724045	Sweep Latch	Cast Zinc
36	71298	Weep Hole Cover	Vinyl
37	41722	Hole Plug	Vinyl
38	724021	Lock Rail Cover, (LH & RH)	Vinyl
39	724050	Pull Rail End Cap	Vinyl
40	724048	Roller Housing & Sash Guide	Vinyl
41	724052	Roller Wheels	Stainless Steel
42	724054	Sash Top Rail Gasket, (LH & RH)	Polyethylene
43	724055	Sash Bot Rail Gasket, (LH & RH)	Polyethylene
44	724057	Frame Header Gasket, (LH & RH)	Polyethylene
45	724058	Frame Sill Gasket, (LH & RH)	Polyethylene
46	724063	Meeting Rail Gasket	Polyethylene
50		Weatherstrip, .187" x .170", Fin Seal @ Sash	
51		Weatherstrip, .187" x .270", Fin Seal @ MR	
52	67070	Bulb Vinyl	
60	710X38PPAX	#10 X 3/8" Ph. PH SMS (Windload Adapter)	Stainless Steel
61	781PQX	#8 X 1" Qd. PH SMS (Frame & Sash Assembly)	Stainless Steel
63	-	Aluminum Screen with Fiberglass Mesh	Varies
70	-	Kommerling Kodispace 4SG TPS	See Sheet 18 for Materials
71	-	Quanex Super Spacer nXT	
72	-	Quanex Duraseal Spacer	
73	-	Cardinal XL Edge Spacer	
74	-	Dow 791, 899, 983 or GE 7700 Backbedding	Silicone

ASSEMBLY DETAILS FOR XO FLANGE FRAMES

(OTHER FRAME TYPES &
CONFIGURATIONS SIMILAR)

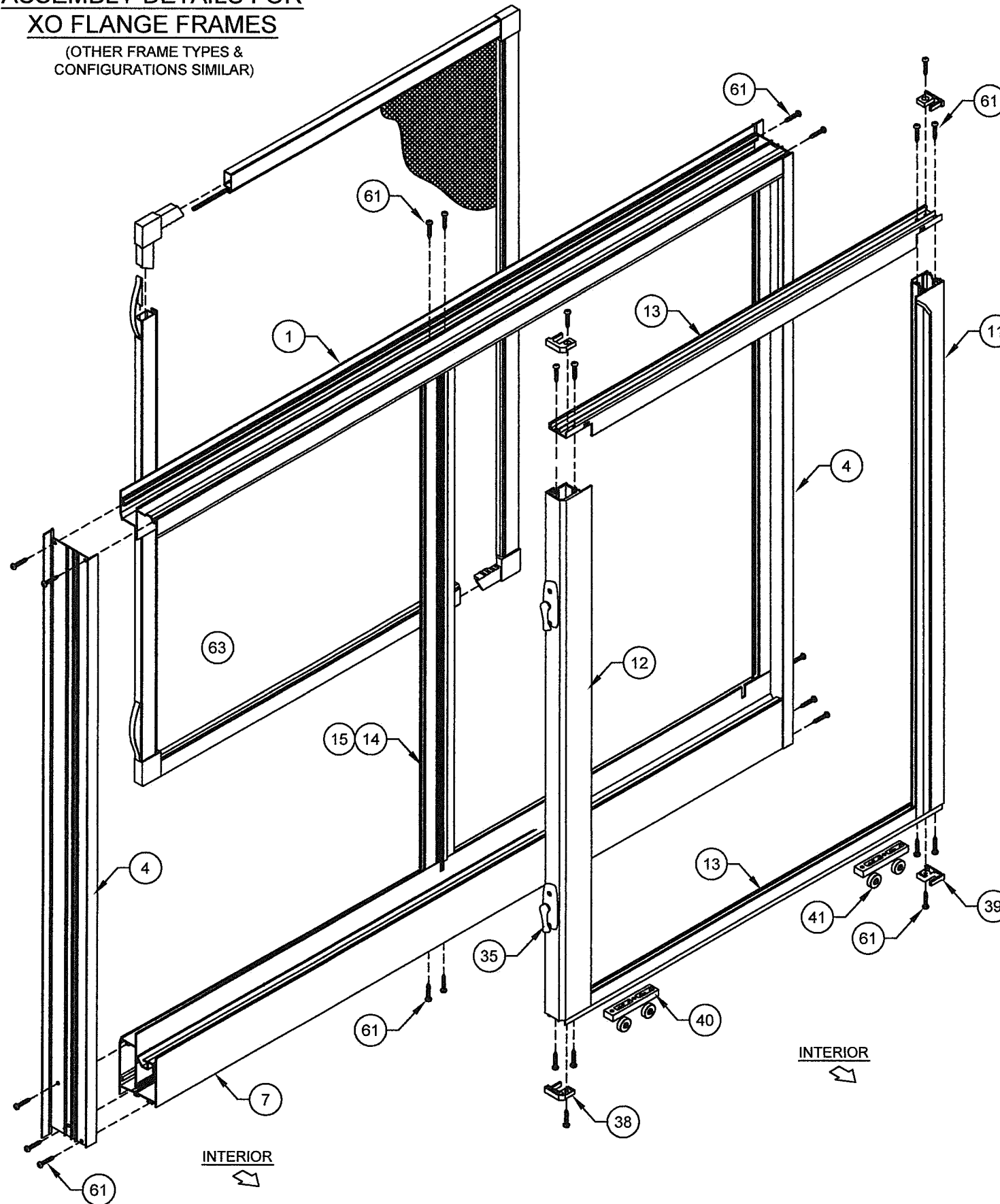

PRODUCT REVISED
as complying with the Florida
Building Code
NOA-No. **20-0406.04**
Expiration Date: **08/23/2023**
By: *Manuel Ferns*
Miami-Dade Product Control

Revision: A) ADDED BACKBEDDING
JR - 03/11/20

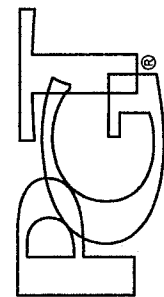
1070 TECHNOLOGY DRIVE N. VENICE, FL 34275 (941) 480-1600	Date	06/30/18	Rev	A
	Drawn By	JENS ROSOWSKI	DWC No.	7710NOA-1
 REGISTRATION #29296 ALUMINUM HORIZ. ROLLER INSTALL. (LM)	Sheet	19 OF 19		
	Series Desc. Title	HR-7710A		

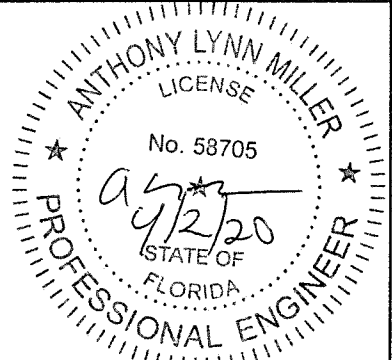
 ANTHONY LYNN MILLER
 LICENSE
 No. 58705
 4/2/20
 STATE OF
 FLORIDA
 PROFESSIONAL ENGINEER
 A. LYNN MILLER, P.E.
 P.E.# 58705