



DEPARTMENT OF REGULATORY AND ECONOMIC RESOURCES (RER)  
 BOARD AND CODE ADMINISTRATION DIVISION  
**NOTICE OF ACCEPTANCE (NOA)**

MIAMI-DADE COUNTY  
 PRODUCT CONTROL SECTION  
 11805 SW 26 Street, Room 208  
 Miami, Florida 33175-2474  
 T (786) 315-2590 F (786) 315-2599  
[www.miamidade.gov/economy](http://www.miamidade.gov/economy)

**Haas Door Company**  
**320 Sycamore Street**  
**Wauseon, OH 43567**

**SCOPE:** This NOA is being issued under the applicable rules and regulations governing the use of construction materials. The documentation submitted has been reviewed and accepted by Miami-Dade County RER-Product Control Section to be used in Miami-Dade County and other areas, where allowed by the Authority Having Jurisdiction (AHJ). This NOA shall not be valid after the expiration date stated below. The Miami-Dade County Product Control Section (In Miami-Dade County) and/or the AHJ (in areas other than Miami-Dade County) reserve the right to have this product or material tested for quality assurance purposes. If this product or material fails to perform in the accepted manner, the manufacturer will incur the expense of such testing and the AHJ may immediately revoke, modify, or suspend the use of such product or material within their jurisdiction. RER reserves the right to revoke this acceptance if it is determined by Miami-Dade County Product Control Section that this product or material fails to meet the requirements of the applicable building code.

This product is approved as described herein and has been designed to comply with the Florida Building Code, including the High Velocity Hurricane Zone.

**DESCRIPTION: Series HT 5000 Insulated Aluminum Sectional Garage Door up to 18ft.-2in. Wide**

**APPROVAL DOCUMENT:** Drawing No. **WL-5000-0218-08-45-50M-D**, titled “18’-2” HT 5000 Aluminum Series HVHZ Wind Load Sectional Door”, sheets 1 through 3 of 3, dated 03/11/2015, with revision **C** dated 10/12/2020, prepared by Haas Door Company, signed and sealed by John E. Scates, P.E., bearing the Miami-Dade County Product Control revision stamp with the Notice of Acceptance number and expiration date by the Miami-Dade County Product Control Section.

**MISSILE IMPACT RATING: Large and Small Missile Impact Resistant**

**LABELING:** A permanent label with the manufacturer’s name or logo, manufacturing address, model number, the positive and negative design pressure rating, indicate impact rated if applicable, installation instruction drawing reference number, approval number (NOA), the applicable test standards, and the statement reading ‘Miami-Dade County Product Control Approved’ is to be located on the door’s side track, bottom angle, or inner surface of a panel.

**RENEWAL** of this NOA shall be considered after a renewal application has been filed and there has been no change in the applicable building code negatively affecting the performance of this product.

**TERMINATION** of this NOA will occur after the expiration date or if there has been a revision or change in the materials, use, and/or manufacture of the product or process. Misuse of this NOA as an endorsement of any product, for sales, advertising or any other purposes shall automatically terminate this NOA. Failure to comply with any section of this NOA shall be cause for termination and removal of NOA.

**ADVERTISEMENT:** The NOA number preceded by the words Miami-Dade County, Florida, and followed by the expiration date may be displayed in advertising literature. If any portion of the NOA is displayed, then it shall be done in its entirety.

**INSPECTION:** A copy of this entire NOA shall be provided to the user by the manufacturer or its distributors and shall be available for inspection at the job site at the request of the Building Official.

This NOA **renews and revises NOA #17-1023.16** and consists of this page 1 and evidence pages E-1, E-2 and E-3, as well as approval document mentioned above.

The submitted documentation was reviewed by **Carlos M. Utrera, P.E.**



NOA-No. 20-1104.12  
 Expiration Date: February 18, 2026  
 Approval Date: January 21, 2021  
 Page 1

**NOTICE OF ACCEPTANCE: EVIDENCE SUBMITTED**

**1. EVIDENCE SUBMITTED UNDER PREVIOUS NOA's**

**A. DRAWINGS “Submitted under NOA #17-0313.13”**

1. Drawing No. **WL-5000-0218-08-45-50M-D**, titled “18'-2” HT 5000 Aluminum Series HVHZ Wind Load Sectional Door”, sheets 1 through 3 of 3, dated 03/11/2015, with revision **A** dated 01/20/2017, prepared by Haas Door Company, signed and sealed by Thomas D. Sullivan, P.E.

**B. TESTS “Submitted under NOA #15-1104.06”**

1. Test reports on 1) Uniform Static Air Pressure Test, Loading per FBC TAS 202-94  
2) Large Missile Impact Test per FBC, TAS 201-94  
3) Cyclic Wind Pressure Loading per FBC, TAS 203-94  
4) Forced Entry Resistance Test, per TAS 202-94  
along with marked-up drawings and installation diagram of 9'-2" wide x 8" height HT 5000 Series Aluminum Sectional Garage Doors, prepared by Intertek/ATI, Test Report No. **E1289.09-550-18**, dated 02/10/2015, signed and sealed by Justin P. McDonald, P.E.
2. Test report on Tensile Test per ASTM E8, of steel sheets, prepared by Intertek/ATI, Test Report No. **E1289.13-106-18**, dated 02/26/2015, signed and sealed by Gary T. Hartman, P.E.

**C. CALCULATIONS “Submitted under NOA #15-1104.06”**

1. Anchor calculations prepared by JB&B Engineering Consultants, LLC, dated 07/01/2015, signed and sealed by Thomas D. Sullivan, P.E.

**D. QUALITY ASSURANCE**

1. Miami-Dade Department of Regulatory and Economic Resources (RER).

**E. MATERIAL CERTIFICATIONS**

1. Test report on Surface Burning Characteristics of the Rubitherm WP 19669 polyurethane foam insulation per ASTM E84, prepared by QAI Laboratories, Test Reports No. **RJ5251F-1** and **RJ5251F-2**, both dated 01/26/2017, signed and sealed by V. Andrew Tan, P.E.
2. Test report on Ignition Temperature of Plastics of the Rubitherm WP 19669 polyurethane foam insulation per ASTM D1929, prepared by QAI Laboratories, Test Report No. **RJ5255F-1**, dated 02/02/2017, signed and sealed by V. Andrew Tan, P.E.



---

**Carlos M. Utrera, P.E.**  
**Product Control Examiner**  
**NOA-No. 20-1104.12**  
**Expiration Date: February 18, 2026**  
**Approval Date: January 21, 2021**

**Haas Door Company**

**NOTICE OF ACCEPTANCE: EVIDENCE SUBMITTED**

**F. STATEMENTS “Submitted under NOA #17-0313.13”**

1. Statement letter of code conformance to the 5<sup>th</sup> edition (2014) FBC issued by JB&B Engineering Consultants, LLC, dated 02/27/2017, signed and sealed by Thomas D. Sullivan, P.E.
2. Statement letter of no financial interest issued by JB&B Engineering Consultants, LLC, dated 02/27/2017, signed and sealed by Thomas D. Sullivan, P.E.

**2. EVIDENCE SUBMITTED UNDER PREVIOUS NOA-No. 17-1023.16**

**A. DRAWINGS**

1. Drawing No. **WL-5000-0218-08-45-50M-D**, titled “18’-2” HT 5000 Aluminum Series HVHZ Wind Load Sectional Door”, sheets 1 through 3 of 3, dated 03/11/2015, with revision **B** dated 10/25/2017, prepared by Haas Door Company, signed and sealed by John E. Scates, P.E.

**B. TESTS**

1. None.

**C. CALCULATIONS**

1. Anchor calculations, dated 10/27/2017, prepared, signed and sealed by John E. Scates, P.E.

**D. QUALITY ASSURANCE**

1. Miami-Dade Department of Regulatory and Economic Resources (RER).

**E. MATERIAL CERTIFICATIONS**

1. None.

**F. STATEMENTS**

1. Statement letter of code conformance to **6<sup>th</sup> Edition (2017) FBC**, dated 10/27/2017, prepared, signed and sealed by John E. Scates, P.E.
2. Statement letter of no financial interest, dated 10/27/2017, issued, signed and sealed by John E. Scates, P.E.



---

**Carlos M. Utrera, P.E.**  
**Product Control Examiner**  
**NOA-No. 20-1104.12**  
**Expiration Date: February 18, 2026**  
**Approval Date: January 21, 2021**

**NOTICE OF ACCEPTANCE: EVIDENCE SUBMITTED**

**3. NEW EVIDENCE SUBMITTED**

**A. DRAWINGS**

1. Drawing No. **WL-5000-0218-08-45-50M-D**, titled “18’-2” HT 5000 Aluminum Series HVHZ Wind Load Sectional Door”, sheets 1 through 3 of 3, dated 03/11/2015, with revision **C** dated 10/12/2020, prepared by Haas Door Company, signed and sealed by John E. Scates, P.E.

**B. TESTS**

1. None.

**C. CALCULATIONS**

1. None.

**D. QUALITY ASSURANCE**

1. Miami-Dade Department of Regulatory and Economic Resources (RER).

**E. MATERIAL CERTIFICATIONS**

1. None.

**F. STATEMENTS**

1. Statement letter of code conformance to **7<sup>th</sup> Edition (2020) FBC**, dated 10/20/2020, prepared, signed and sealed by John E. Scates, P.E.
2. Statement letter of no financial interest, dated 10/20/2020, issued, signed and sealed by John E. Scates, P.E.



---

**Carlos M. Utrera, P.E.**  
**Product Control Examiner**  
**NOA-No. 20-1104.12**  
**Expiration Date: February 18, 2026**  
**Approval Date: January 21, 2021**

REVISIONS				
REV.	ZONE	BY	DESCRIPTION	DATE
A1			Sheet 2 Added "NOTE: The flat...mount"	
A2			Sheet 2 Added "3" Nominal...on Alternate."	
A	E6&D1&2	MVS	Sheet 2 Added 3 Alternate Bottom Brackets To <u>DETAIL C</u> .	1/20/17
E3			Sheet 3 Added "WOOD JAMB ATTACHMENT"	
B2			Sheet 3 Changed FR Polyurethane Foam	
B	D3,D4,E3&E4	MVS	Sheet 3 Changed some values in the WOOD JAMB ATTACHMENT chart	10/25/17
C	A4	MVS	Changed the roller hub distance from 1/4" to 1/2" in <u>DETAIL K</u> on sheet 2 of 3.	10/12/20

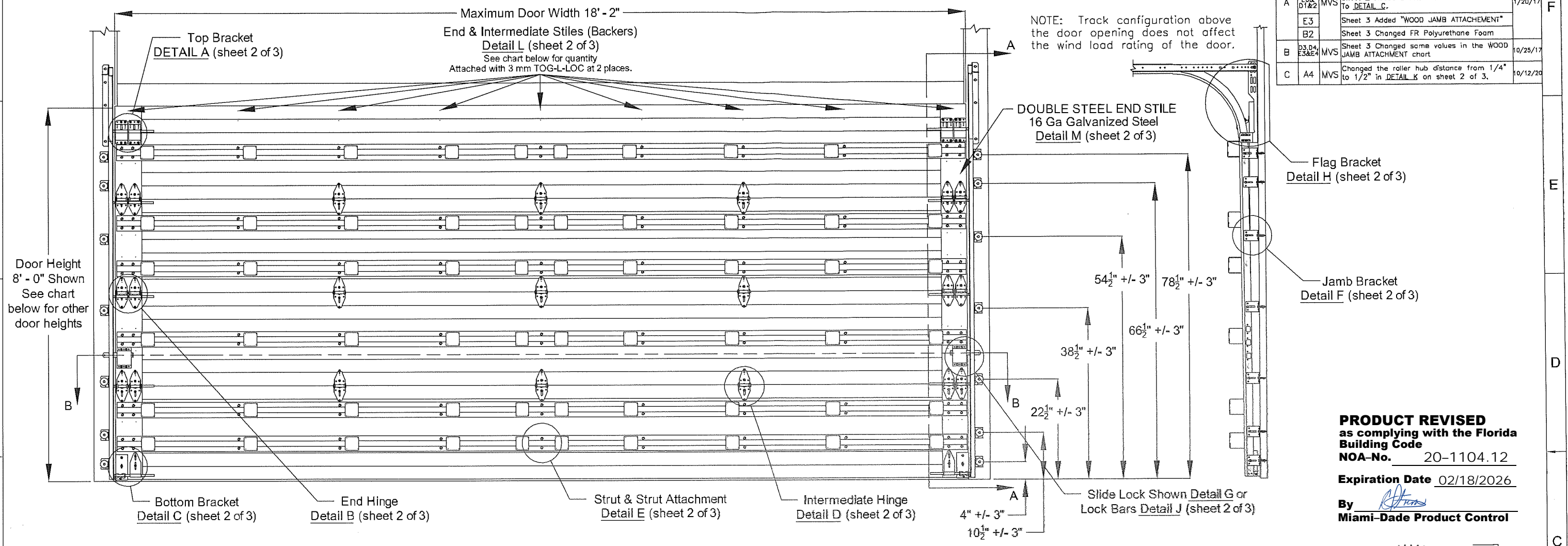

**PRODUCT REVISED**  
as complying with the Florida Building Code  
NOA-No. 20-1104.12  
Expiration Date 02/18/2026  
By *[Signature]*  
Miami-Dade Product Control

This product has been tested per TAS202-94 for static air pressure.  
This product has been tested per TAS201/203-94 for large missile impact and cyclic wind pressure.

Door Width	Design Pressures		End Backers	Model Number										Impact Resistant
	+ psf	- psf		Center		Center		Center		Center				
				Stiles	Hinges	Stiles	Hinges	Stiles	Hinges	Stiles	Hinges			
16'-3" thru 18'-2"	45	-50	Double	7	3	7	3	7	3	7	3	7	3	YES

This product is available in narrower sizes with the same PSF and constructed as shown.  
This product is designed and sold by PSF. The AHJ or Engineer of Record is responsible for determining the PSF required for any given site.

Jamb bracket quantities shown are for use with grade 2 or better southern pine jambs.  
Supporting structural element designs are to be the responsibility of the professional of record for the building or structure for the loads listed on this drawing.

Door Height	Total No. of Sections	Total No. of Struts	Strut Configuration	Jamb Brkts/ Side
6'-0"	3	5	SEE SHEET 3 OF 3	5
6'-0"	4	6		5
6'-3"	4	6		5
6'-6"	4	6		6
6'-9"	4	6		6
7'-0"	4	6		6
7'-3"	4	6		6
7'-6"	4	6		7
7'-6"	5	8		7
7'-9"	4	6		7
7'-9"	5	8		7
8'-0"	4	6		7
8'-0"	5	8	7	

**NOTICE:**  
These drawings are a supplement to the installation instructions for a standard door and only covers those procedures that vary from standard door installation. If these specific procedures are not followed, the door may not perform as designed.

*John E Scates*  
10/16/2020

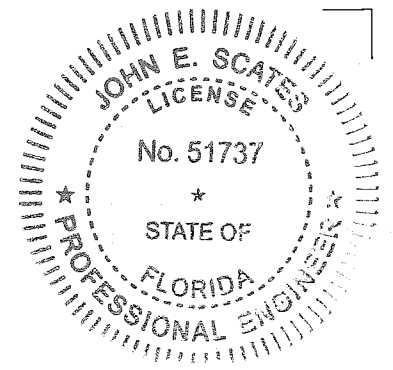

John E Scates, P.E.  
2560 King Arthur Blvd, Ste 124-54  
Lewisville, Texas 75056  
Florida P.E. # 51737

	IMPACT RESISTANT	This product has been evaluated for use in the High Velocity Hurricane Zone (HVHZ).
	18'2" HT 5000 ALUMINUM SERIES HVHZ WIND LOAD SECTIONAL DOOR DESIGN PRESSURE +45.0/-50.0 PSF	
320 Sycamore Wauseon, Ohio 43567 419-337-9900 <small>© Copyrig 42014</small>	DRAWING NO.: WL-5000-0218-08-45-50M-D REV. C DATE DRN: 3/11/15 DRAWN BY: MVS REV. DATE: 10/12/2020 MODEL(S): See Sheet 3 SHEET: 1 OF 3	

Maximum section height is 24 in.  
Maximum door height is 16 ft.  
All doors, even those above the tested height, are available with jamb brackets or commercial full angle. The quantity and dimensional location of the jamb brackets/track clips and the jamb mounting shown above should be maintained.

REVISIONS				
REV.	ZONE	BY	DESCRIPTION	DATE
A1			Sheet 2 Added "NOTE: The flat...mount"	
A2			Sheet 2 Added "3" Nominal...an Alternate."	
E3			Sheet 2 Added 3 Alternate Bottom Brackets To <u>DETAIL C</u> .	1/20/17
B2			Sheet 3 Added "WOOD JAMB ATTACHMENT"	
B3			Sheet 3 Changed FR Polyurethane Foam	
B3, D4, E3 & E4		MVS	Sheet 3 Changed some values in the WOOD JAMB ATTACHMENT chart	10/25/17
C	A4	MVS	Changed the roller hub distance from 1/4" to 1/2" in <u>DETAIL K</u> on sheet 2 of 3.	10/12/20

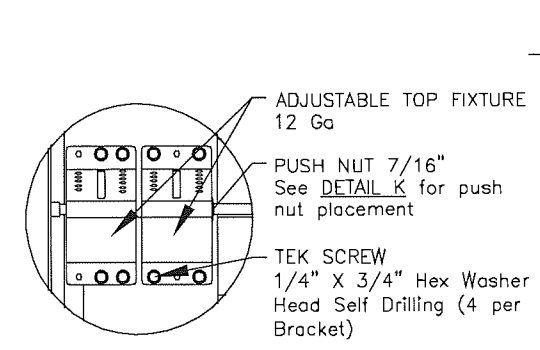

**DETAIL A**

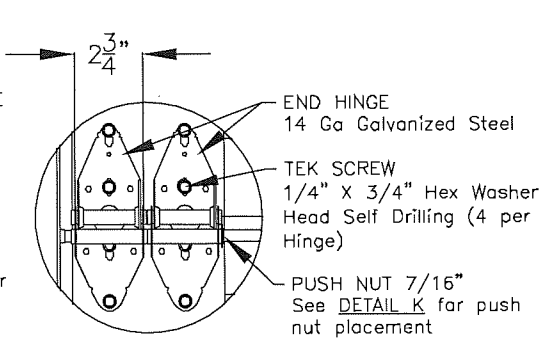

**DETAIL B**

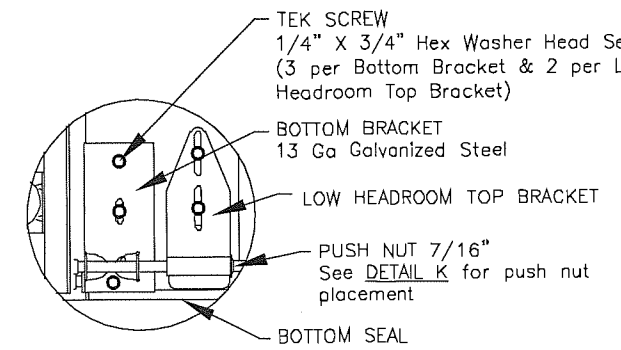

**DETAIL C**

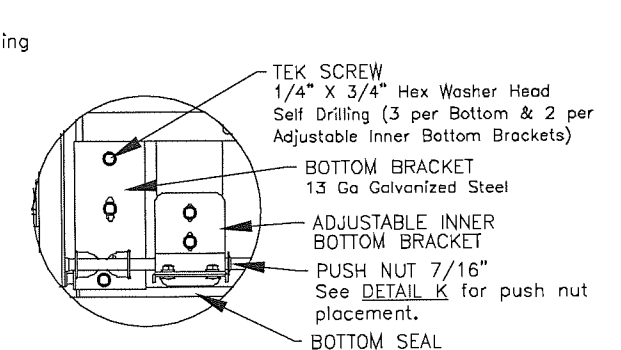

**ALTERNATE #1 TO DETAIL C**

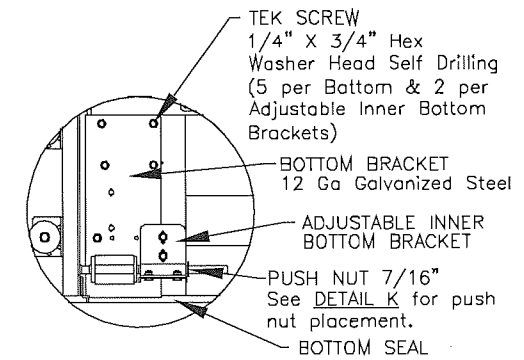

**ALTERNATE #2 TO DETAIL C**

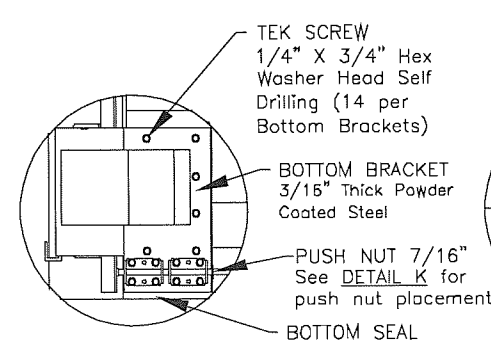

**ALTERNATE #3 TO DETAIL C**

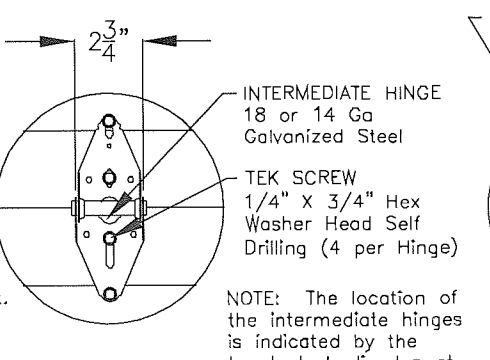

**DETAIL D**

NOTE: The location of the intermediate hinges is indicated by the toggle lock dimples at the top of each section.

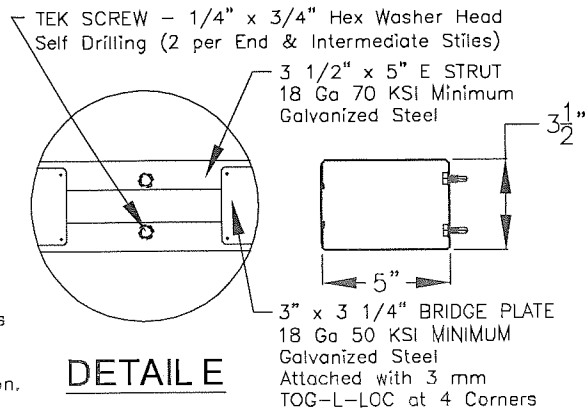

**DETAIL E**

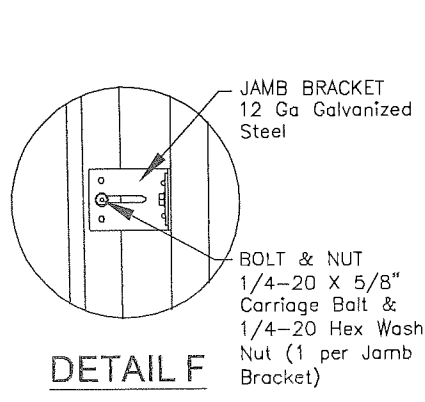

**DETAIL F**

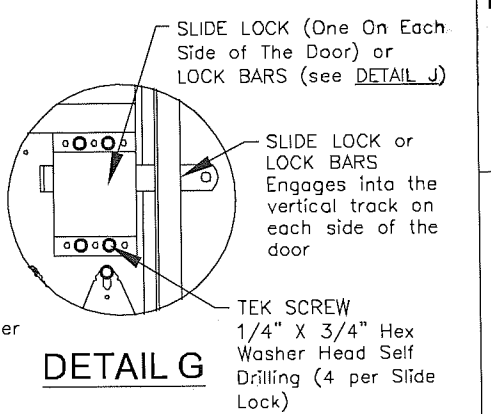

**DETAIL G**

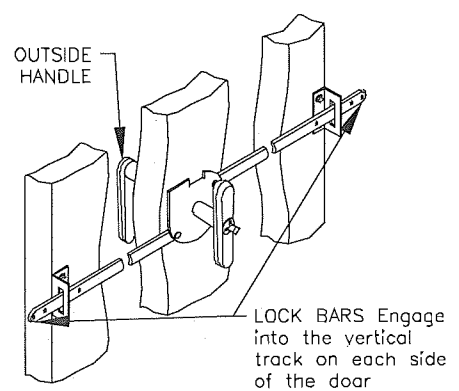

**DETAIL J**

Alternate Lock Configuration

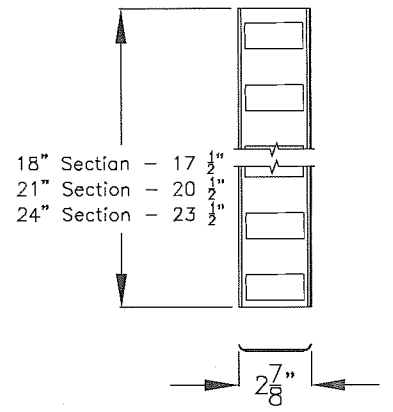

**DETAIL L**

MATERIAL: 20 GA CS Steel, G40 Min. Hot Dipped Galvanized

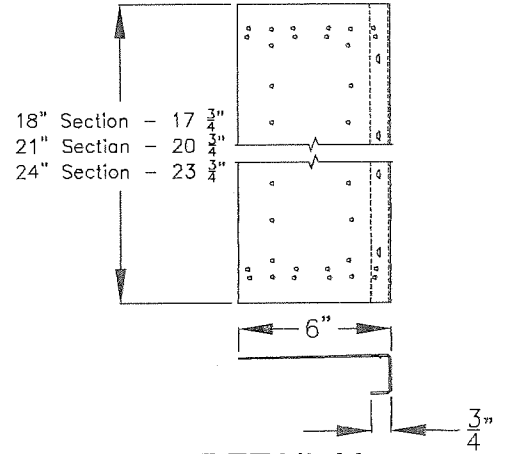

**DETAIL M**

MATERIAL: 16 GA CS Steel, G40+ Min. Hot Dipped Galvanized

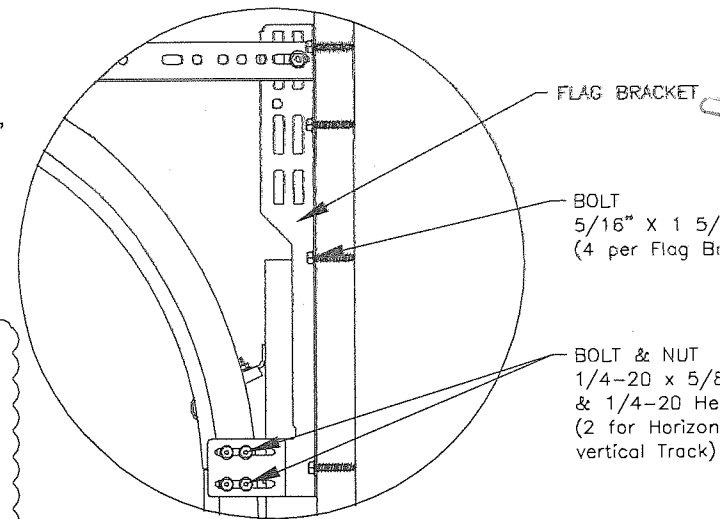
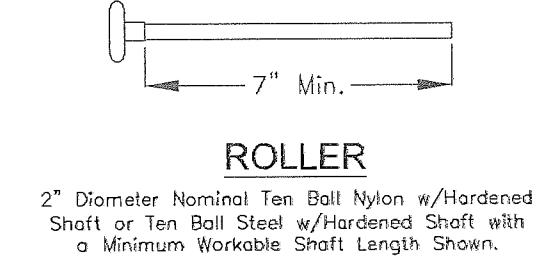

**DETAIL H**

NOTE: Details on some views omitted for clarity. Double end stiles and end hardware may be required on wider or heavier doors.

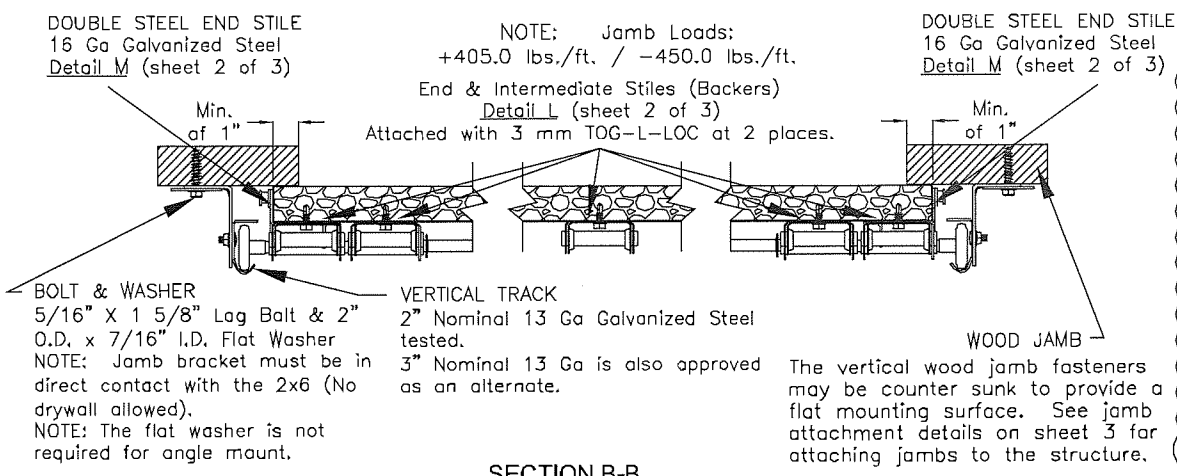
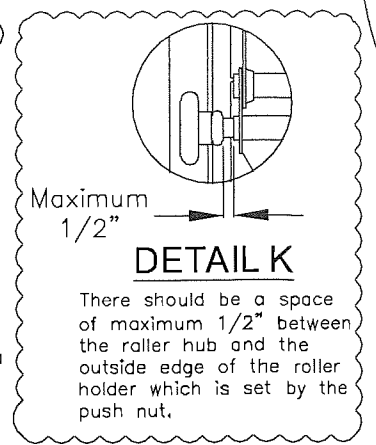

**PRODUCT REVISED**  
as complying with the Florida Building Code  
NOA-No. 20-1104.12  
Expiration Date 02/18/2026  
By *[Signature]*  
Miami-Dade Product Control

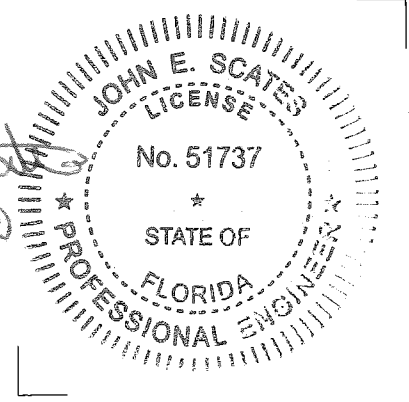

John E. Scates, P.E.  
2560 King Arthur Blvd. Ste 124-54  
Lewisville, Texas 75056  
Florida P.E. # 51737

IMPACT RESISTANT	This product has been evaluated for use in the High Velocity Hurricane Zone (HVHZ).
	18'2" HT 5000 ALUMINUM SERIES HVHZ WIND LOAD SECTIONAL DOOR DESIGN PRESSURE +45.0/-50.0 PSF
320 Sycamore Wauseon, Ohio 43567 419-337-9900 © Copyright 2014	DRAWING NO.: WL-5000-0218-08-45-50M-D REV. C DATE DRN: 3/11/15 DRAWN BY: MVS REV. DATE: 10/12/2020 MODEL(S): See Sheet 3 SHEET: 2 OF 3

REVISIONS				
REV.	ZONE	BY	DESCRIPTION	DATE
A1			Sheet 2 Added "NOTE: The flat...mount"	
A2			Sheet 2 Added "3" Nominal...on Alternate."	
A	E6&D1&2	MVS	Sheet 2 Added 3 Alternate Bottom Brackets To DETAIL C.	1/20/17
E3			Sheet 3 Added "WOOD JAMB ATTACHEMENT"	
B2			Sheet 3 Changed FR Polyurethane Foam	
B	03,04, E3&E4	MVS	Sheet 3 Changed some values in the WOOD JAMB ATTACHEMENT chart	10/25/17
C	A4	MVS	Changed the roller hub distance from 1/4" to 1/2" in DETAIL K on sheet 2 of 3.	10/12/20

WOOD JAMB ATTACHMENT						
Building Structure	Fastener Type	Minimum Embedment	Minimum Edge Distance	Minimum on Center Spacing	Maximum on Center Spacing	Allowable Tension Load
Min. 2000 PSI Concrete	Tapcon 1/4" w/ 1" OD washer	1 3/4"	2 1/2"	4"	12"	443 #
Southern Pine (G = 0.55)	3/8" Lag w/ 1 1/8" OD washer	1 1/2"	1 1/2"	4"	12"	620 #
Spruce Pine Fir (G = 0.42)	3/8" Lag w/ 1 1/8" OD washer	1 1/2"	2"	4"	12"	482 #

NOTE: 2X6 mounted to the wall must be Southern Pine Grade 2 or better.

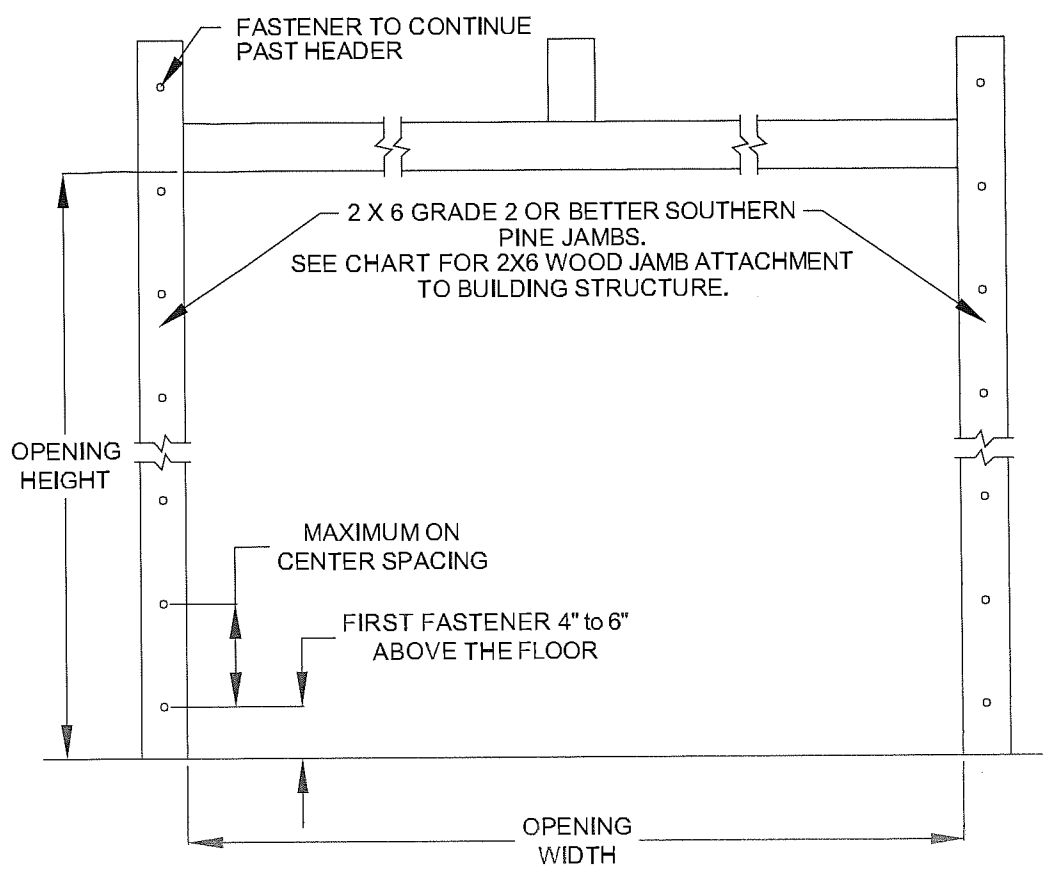

### MODEL NUMBERS

MODEL NUMBERS AVAILABLE
HT 5 _10 SERIES
HT 5 _12 SERIES
HT 5 _14 SERIES
HT 5 _16 SERIES
HT 5 _70 SERIES
HT5 _80 SERIES

**PRODUCT REVISED**  
 as complying with the Florida Building Code  
 NOA-No. 20-1104.12  
 Expiration Date 02/18/2026  
 By *[Signature]*  
 Miami-Dade Product Control

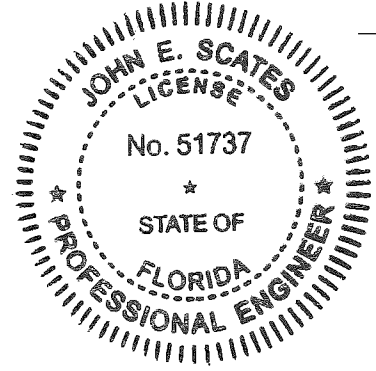

*John E. Scates*  
 10/16/2020

John E. Scates, P.E.  
 2560 King Arthur Blvd. Ste 124-54  
 Lewisville, Texas 75056  
 Florida P.E. # 51737

IMPACT RESISTANT	This product has been evaluated for use in the High Velocity Hurricane Zone (HVHZ).
Haas Door A Noeliger Company	18'2" HT 5000 ALUMINUM SERIES HVHZ WIND LOAD SECTIONAL DOOR DESIGN PRESSURE +45.0/-50.0 PSF
320 Sycamore Wauseon, Ohio 43567 419-337-9900 © Copyright 2014	DRAWING NO.: WL-5000-0218-08-45-50M-D REV. C DATE DRN: 3/11/15 DRAWN BY: MVS REV. DATE: 10/12/2020 MODEL(S): See Sheet 3 SHEET: 3 OF 3

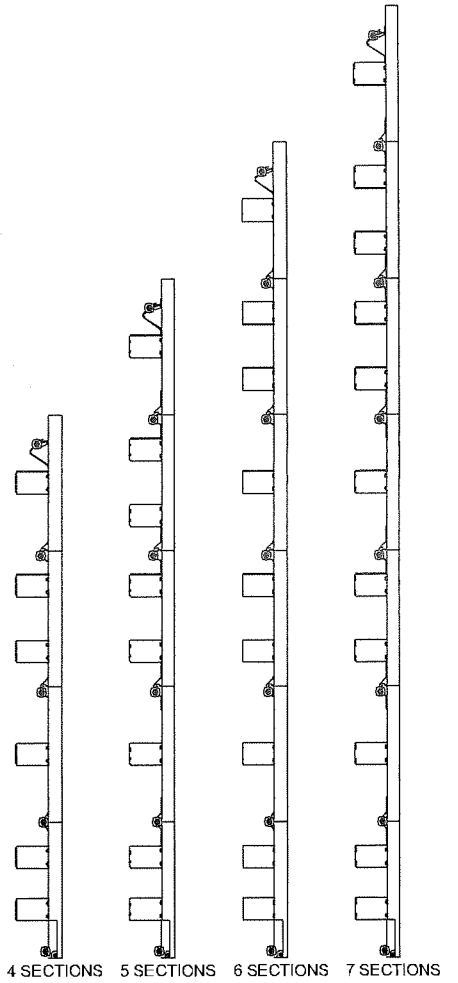
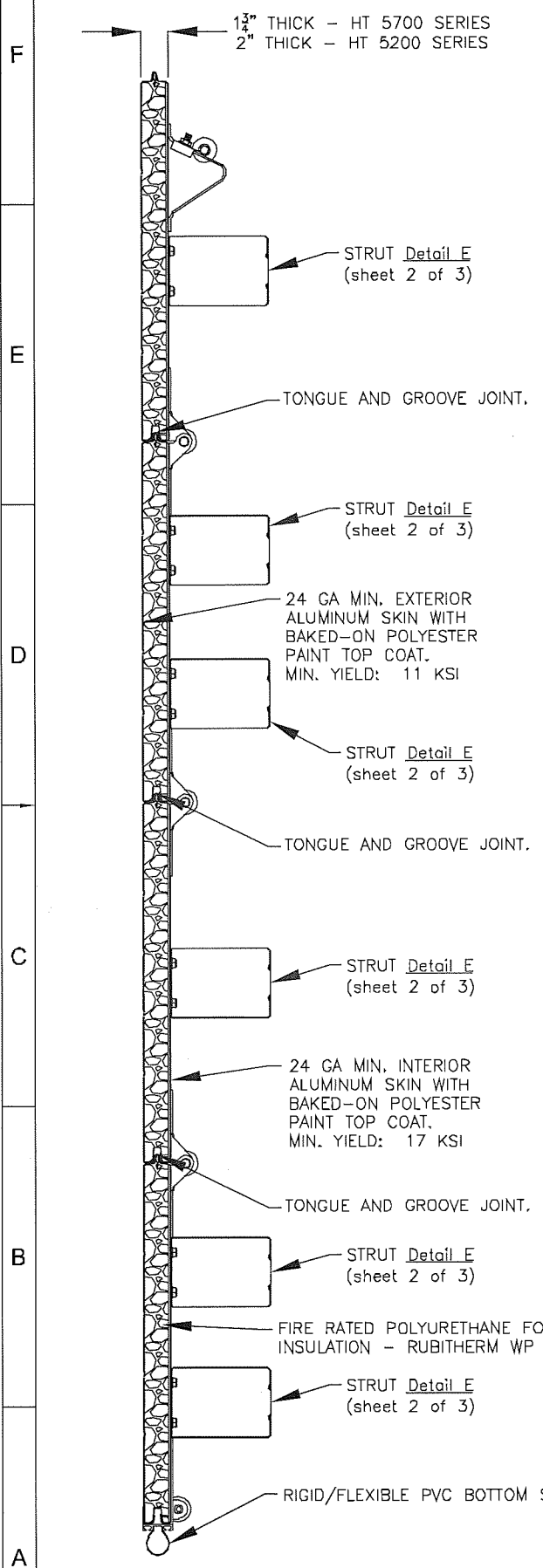

4 SECTIONS 5 SECTIONS 6 SECTIONS 7 SECTIONS  
 STRUT CONFIGURATION

SECTION A-A