



DEPARTMENT OF REGULATORY AND ECONOMIC RESOURCES (RER)
BOARD AND CODE ADMINISTRATION DIVISION

MIAMI-DADE COUNTY
PRODUCT CONTROL SECTION

11805 SW 26 Street, Room 208
Miami, Florida 33175-2474
T (786) 315-2590 F (786) 315-2599

www.miamidade.gov/economy

NOTICE OF ACCEPTANCE (NOA)

Dan's Custom Sheet Metal, Inc.
5700 Washington Street
Naples, FL. 34109

SCOPE:

This NOA is being issued under the applicable rules and regulations governing the use of construction materials. The documentation submitted has been reviewed and accepted by Miami-Dade County RER - Product Control Section to be used in Miami-Dade County and other areas where allowed by the Authority Having Jurisdiction (AHJ).

This NOA shall not be valid after the expiration date stated below. The Miami-Dade County Product Control Section (in Miami-Dade County) and/or the AHJ (in areas other than Miami-Dade County) reserve the right to have this product or material tested for quality assurance purposes. If this product or material fails to perform in the accepted manner, the manufacturer will incur the expense of such testing and the AHJ may immediately revoke, modify, or suspend the use of such product or material within their jurisdiction. RER reserves the right to revoke this acceptance, if it is determined by Miami-Dade County Product Control Section that this product or material fails to meet the requirements of the applicable building code.

This product is approved as described herein, and has been designed to comply with the Florida Building Code including the High Velocity Hurricane Zone of the Florida Building Code.

DESCRIPTION: D.C.S.M. R-Panel

LABELING: Each unit shall bear a permanent label with the manufacturer's name or logo, city, state and the following statement: "Miami-Dade County Product Control Approved", unless otherwise noted herein.

RENEWAL of this NOA shall be considered after a renewal application has been filed and there has been no change in the applicable building code negatively affecting the performance of this product.

TERMINATION of this NOA will occur after the expiration date or if there has been a revision or change in the materials, use, and/or manufacture of the product or process. Misuse of this NOA as an endorsement of any product, for sales, advertising or any other purposes shall automatically terminate this NOA. Failure to comply with any section of this NOA shall be cause for termination and removal of NOA.

ADVERTISEMENT: The NOA number preceded by the words Miami-Dade County, Florida, and followed by the expiration date may be displayed in advertising literature. If any portion of the NOA is displayed, then it shall be done in its entirety.

INSPECTION: A copy of this entire NOA shall be provided to the user by the manufacturer or its distributors and shall be available for inspection at the job site at the request of the Building Official.

This NOA renews NOA #15-0709.18 and consists of pages 1 through 5.
The submitted documentation was reviewed by Alex Tigera.



NOA No: 21-0112.03
Expiration Date: 11/03/26
Approval Date: 09/23/21
Page 1 of 5

ROOFING ASSEMBLY APPROVAL

Category: Roofing
Sub-Category: Metal, Panels (Non-Structural)
Material: Steel
Deck Type: Wood
Maximum Design Pressure: -84.25 psf

TRADE NAMES OF PRODUCTS MANUFACTURED OR LABELED BY APPLICANT:

<u>Product</u>	<u>Dimensions</u>	<u>Test Specifications</u>	<u>Product Description</u>
D.C.S.M. R-Panel	L = 119-1/2" W = 36" H = 1-1/4" Thickness = 0.019" (26GA)	TAS 125	Galvalume, preformed, coated panels.
Trim Pieces	L = varies W = varies Thickness = 0.019" (26GA)	TAS 110	Standard flashing and trim pieces. Manufactured for each panel.

MANUFACTURING LOCATION:

- Naples, FL

EVIDENCE SUBMITTED

<u>Test Agency</u>	<u>Test Identifier</u>	<u>Test Name/Report</u>	<u>Date</u>
PRI Construction Materials Technologies	DCSM-026-02-01	TAS 100	10/23/15
	VLS-015-02-01	ASTM B117	05/15/18
	VLS-015-02-01	ASTM G 155	05/15/18
Hurricane Test Laboratory, Inc.	0302-0403-05	TAS 125	07/07/05



APPROVED ASSEMBLIES:

System: D.C.S.M. R-Panel
Deck Type: Wood, Non-Insulated
Deck Description: New Construction ¹⁹/₃₂" or greater plywood or wood plank.
Slope Range: 2": 12" or greater
Maximum Uplift Pressure: See Table A below

Deck Attachment: Deck shall be attached in accordance with applicable Building Code, but in no case shall it be less than 8d x 2-1/2" galvanized ring shank roofing nails spaced 6" OC at roof perimeter and field. In reroofing, where the deck is less than ¹⁹/₃₂" thick (Minimum ¹⁵/₃₂") the above attachment method must be in addition to existing attachment.

Underlayment: Minimum underlayment shall be an ASTM D 226 Type II installed with a minimum 4" side-lap and 6" end-laps. Underlayment shall be fastened with corrosion resistant 32 gauge tin-caps and 12 gauge 1-1/4" annular galvanized ring-shank roofing nails, spaced 6" OC at all laps and two staggered rows 12" OC in the field of the roll or any approved underlayment having a current NOA.

Fire Barrier Board: Any approved fire barrier having a current NOA. Refer to a current fire directory listing for fire ratings of this roofing system assembly as well as the location of the fire barrier within the assembly. See Limitation # 1.

Valleys: Valley construction shall be in compliance with Roofing Application Standard RAS 133 and with Dan's Custom Sheet Metal, Inc.'s current published installation instructions.

Metal Panels and Accessories: Install the "D.C.S.M. R-Panel" and accessories in compliance with Dan's Custom Sheet Metal, Inc. current published installation instructions and details. Flashing, penetrations, valley construction and other details shall be constructed in compliance with the minimum requirements provided in Roofing Application Standards RAS 133.

Each roof panel is attached to the plywood substrate along its center rib and overlaps using min. #10 hex head screw with neoprene seal washers of sufficient length to penetrate through the sheathing a minimum of 3/16" located 2" from each panel end and 16" OC thereafter.

Panel ends shall be attached to the plywood substrate using min. #10 hex head screw with neoprene seal washers of sufficient length to penetrate through the sheathing a minimum of 3/16" located 2" from each panel end and 6" OC thereafter

**TABLE A
 MAXIMUM DESIGN PRESSURES**

Roof Areas	Field	Perimeter and Corner¹
Maximum Design Pressures	-73 psf	-84.25 psf
Maximum Fastener Spacing	16" o.c.	12" o.c.

1. Extrapolation shall not be allowed



SYSTEM LIMITATIONS

- 1 Fire classification is not part of this acceptance; refer to a current Approved Roofing Materials Directory for fire ratings of this product.
- 2 The maximum designed pressure listed herein shall be applicable to all roof pressure zones (i.e. field, perimeters, and corners). Neither rational analysis, nor extrapolation shall be permitted for enhanced fastening at enhanced pressure zones (i.e. perimeters, extended corners and corners).
- 3 Panels may be rolls formed in continuous lengths from eave to ridge. Maximum lengths shall be as described in Roofing Application Standard RAS 133
- 4 All panels shall be permanently labeled with the manufacturer's name and/or logo, and the following statement: "Miami-Dade County Product Control Approved" **or** with the Miami-Dade County Product Control Seal as seen below. All clips shall be permanently labeled with the manufacturer's name and/or logo, and/or model.



5. All products listed herein shall have a quality assurance audit in accordance with the Florida Building Code and Rule 61G20-3 of the Florida Administrative Code.



PROFILE DRAWINGS

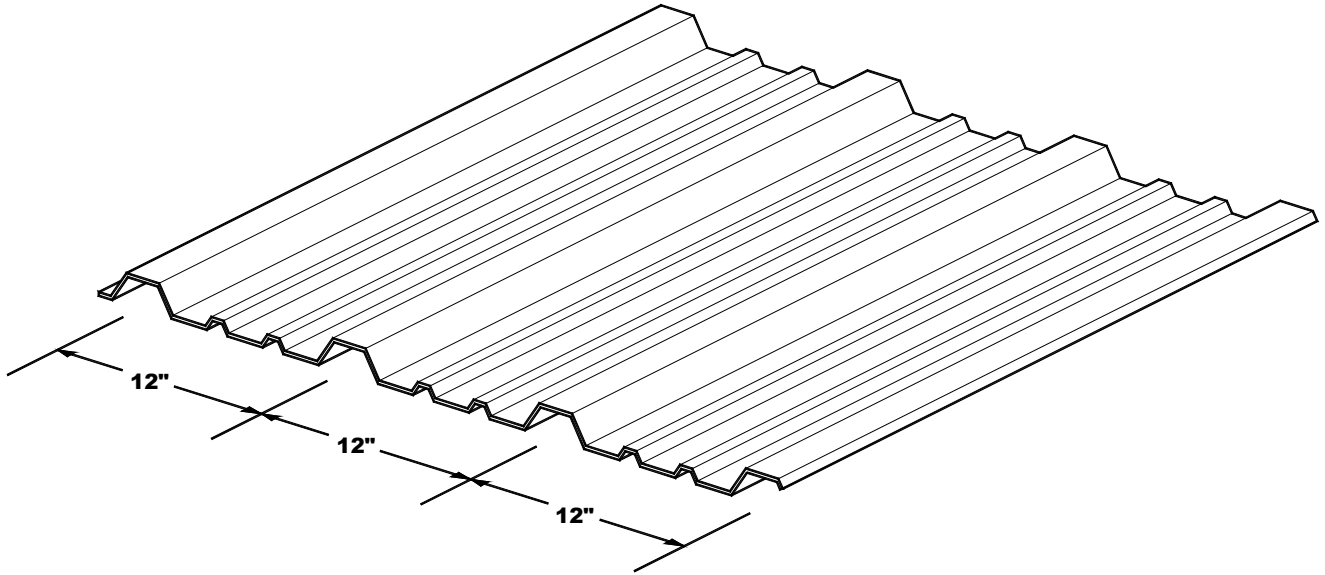

D.C.S.M. R-PANEL METAL PANEL

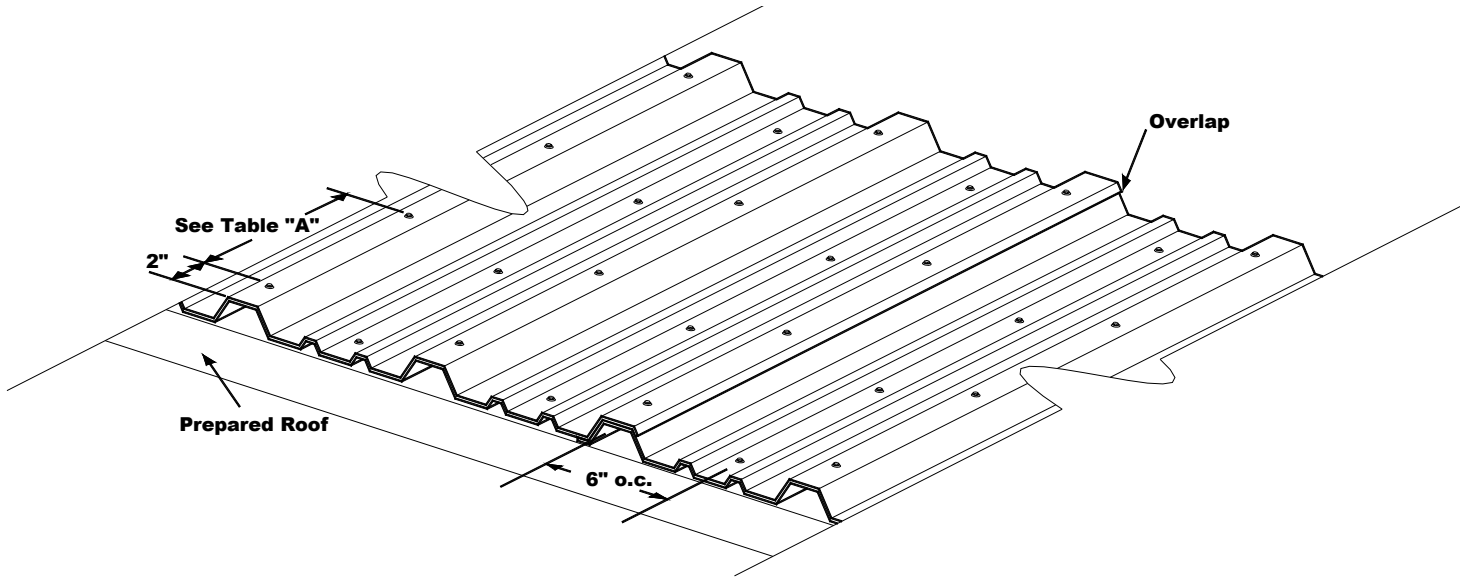

FASTENING PATTERN

END OF THIS ACCEPTANCE

