



DEPARTMENT OF REGULATORY AND ECONOMIC RESOURCES (RER)
BOARD AND CODE ADMINISTRATION DIVISION

MIAMI-DADE COUNTY
PRODUCT CONTROL SECTION

11805 SW 26 Street, Room 208
Miami, Florida 33175-2474
T (786) 315-2590 F (786) 315-2599
www.miamidade.gov/economy

NOTICE OF ACCEPTANCE (NOA)

Lomanco, Inc.
2101 West Main Street
Jacksonville, AR 72076

SCOPE:

This NOA is being issued under the applicable rules and regulations governing the use of construction materials. The documentation submitted has been reviewed and accepted by Miami-Dade County RER - Product Control Section to be used in Miami-Dade County and other areas where allowed by the Authority Having Jurisdiction (AHJ).

This NOA shall not be valid after the expiration date stated below. The Miami-Dade County Product Control Section (in Miami-Dade County) and/or the AHJ (in areas other than Miami-Dade County) reserve the right to have this product or material tested for quality assurance purposes. If this product or material fails to perform in the accepted manner, the manufacturer will incur the expense of such testing and the AHJ may immediately revoke, modify, or suspend the use of such product or material within their jurisdiction. RER reserves the right to revoke this acceptance, if it is determined by Miami-Dade County Product Control Section that this product or material fails to meet the requirements of the applicable building code.

This product is approved as described herein, and has been designed to comply with the Florida Building Code including the High Velocity Hurricane Zone of the Florida Building Code.

DESCRIPTION: 135 Roof Vent, Lomancool 2000 Power Vent

LABELING: Each unit shall bear a permanent label with the manufacturer's name or logo, city, state and following statement: "Miami-Dade County Product Control Approved", unless otherwise noted herein.

RENEWAL of this NOA shall be considered after a renewal application has been filed and there has been no change in the applicable building code negatively affecting the performance of this product.

TERMINATION of this NOA will occur after the expiration date or if there has been a revision or change in the materials, use, and/or manufacture of the product or process. Misuse of this NOA as an endorsement of any product, for sales, advertising or any other purposes shall automatically terminate this NOA. Failure to comply with any section of this NOA shall be cause for termination and removal of NOA.

ADVERTISEMENT: The NOA number preceded by the words Miami-Dade County, Florida, and followed by the expiration date may be displayed in advertising literature. If any portion of the NOA is displayed, then it shall be done in its entirety.

INSPECTION: A copy of this entire NOA shall be provided to the user by the manufacturer or its distributors and shall be available for inspection at the job site at the request of the Building Official.

This NOA renews NOA No.16-0510.25 and consists of pages 1 through 4.
The submitted documentation was reviewed by Alex Tigera.



NOA No.: 21-0323.07
Expiration Date: 08/17/26
Approval Date: 07/29/21
Page 1 of 4

ROOFING COMPONENT APPROVAL

Category: Roofing
Sub-Category: Ventilation
Material: Aluminum

TRADE NAMES OF PRODUCTS MANUFACTURED OR LABELED BY APPLICANT:

<u>Product</u>	<u>Dimensions</u>	<u>Test Specification</u>	<u>Product Description</u>
135 Roof Vent, Lomancool 2000 Power Vent	9" x 28.5"	TAS 100	Powered Roof Vent, with fan and thermostat with a aluminum hood.

MANUFACTURING LOCATION

1. Jacksonville, AR

EVIDENCE SUBMITTED:

<u>Test Agency</u>	<u>Test Name/Report</u>	<u>Test Identifier</u>	<u>Date</u>
Intertek-ATI	TAS 100(A)	F7517.03-801-18	07/08/16



NOA No.: 21-0323.07
Expiration Date: 08/17/26
Approval Date: 07/29/21
Page 2 of 4

APPROVED APPLICATIONS

Cutout: Vent must be located 18" from ridgeline. At chosen location and centered between two roof rafters, cut a 14" diameter hole through shingles and sheathing boards.

Using marked position as center point; scribe a circle that is the same diameter as the vent throat opening. Starting with the drill hole cut vent hole.

Installation: Vents should be evenly spaced on the rear slope of the roof.

Remove roofing nails from top row of shingles so the flashing of the roof vent will slide under shingles. Apply approved roof cement around the edge of the hole. Carefully slide base of vent under shingles with arrow facing up. Make sure the throat of the vent is centered over vent hole. Fasten the base to roof decking at corners, and approx. 4" o.c. 1" from the outside edge of the flange and 1" from stack every 45° with approved roofing nails, keeping heads of nails under shingles where possible. Use a minimum of 32 nails and shall be of sufficient length to penetrate through roof sheathing a minimum of ½". See details drawings herein. Seal all seams and nails with roofing cement.

Net Free Area: Refer to manufacturers published literature

LIMITATIONS:

1. Refer to applicable building codes for required ventilation.
2. 135 Roof Vent, Lomancool 2000 Power Vent, thermostat and wiring shall be installed in compliance with Lomanco, Inc. published instructions, and in accordance with applicable Building Codes.
3. This acceptance is for installations over asphaltic shingle roofs only.
4. 135 Roof Vent, Lomancool 2000 Power Vent, shall not be installed on roof mean heights greater than 33 feet.
5. All products listed herein shall have a quality assurance audit in accordance with the Florida Building Code and Rule 61G20-3 of the Florida Administrative Code



NOA No.: 21-0323.07
Expiration Date: 08/17/26
Approval Date: 07/29/21
Page 3 of 4

DETAIL DRAWINGS

135 Roof Vent, Lomancool 2000 Power Vent

PART #	ITEM	REQ	DESCRIPTION	MATERIAL	MAT WT
0201-501	1	1	DOME	.032±.0025 X 28.50 X 28.50 5005-0 AL	3.250#
0201-502	2	1	BASE	.032±.0025 X 20 X 23 5005-0 AL	1.840#
0201-503	3	1	RAINSHIELD	.019±.0025 X 19.50 X 19.50 5005-0 AL	.913#
0410-501	4	3	BRACKET	16 GA. X 1.250 X 7.580 GALV. STEEL	.195#
0201-507	5	1	SCREEN	.028 X 5 X 41.375-8X8 MESH PERM-A-KOTE	
1404000165	6	12	RIVET	3/16ø X 7/32 OVAL HD. AL	
1405000281	7	3	SCREW	#14 X 1/2 HWUHD TYPEN "AB" ZINC PLT	

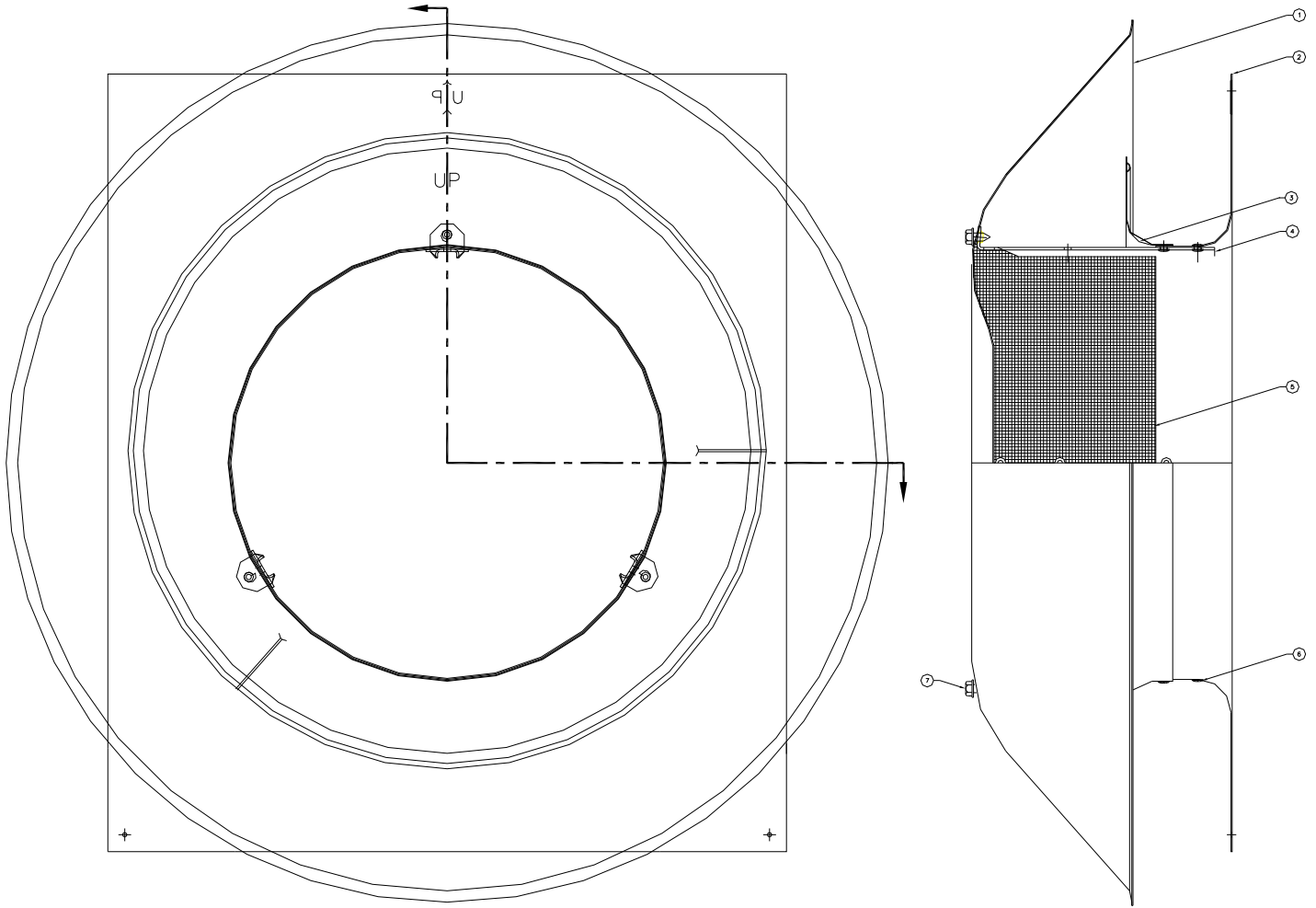

END OF THIS ACCEPTANCE



NOA No.: 21-0323.07
 Expiration Date: 08/17/26
 Approval Date: 07/29/21
 Page 4 of 4