



DEPARTMENT OF REGULATORY AND ECONOMIC RESOURCES (RER)
BOARD AND CODE ADMINISTRATION DIVISION
NOTICE OF ACCEPTANCE (NOA)

MIAMI-DADE COUNTY
PRODUCT CONTROL SECTION
11805 SW 26 Street, Room 208
Miami, Florida 33175-2474
T (786) 315-2590 F (786) 315-2599
www.miamidade.gov/economy

Dryvit Systems, Inc.
One Energy Way
West Warwick, RI 02893

SCOPE: This NOA is being issued under the applicable rules and regulations governing the use of construction materials. The documentation submitted has been reviewed and accepted by Miami-Dade County RER-Product Control Section to be used in Miami Dade County and other areas where allowed by the Authority Having Jurisdiction (AHJ).

This NOA shall not be valid after the expiration date stated below. The Miami-Dade County Product Control Section (In Miami Dade County) and/or the AHJ (in areas other than Miami Dade County) reserve the right to have this product or material tested for quality assurance purposes. If this product or material fails to perform in the accepted manner, the manufacturer will incur the expense of such testing and the AHJ may immediately revoke, modify, or suspend the use of such product or material within their jurisdiction. RER reserves the right to revoke this acceptance, if it is determined by Miami-Dade County Product Control Section that this product or material fails to meet the requirements of the applicable building code.

This product is approved as described herein and has been designed to comply with the Florida Building Code, including the High Velocity Hurricane Zone.

DESCRIPTION: Outsulation and Outsulation Plus MD EIF Systems over Concrete/Concrete Blocks

APPROVAL DOCUMENT: Drawing No. **OSOPLCONCBLK**, titled "Outsulation System or Outsulation Plus MD System over Concrete or Concrete Block", sheets 1 through 3 of 3, dated 10/08/2009, prepared by Dryvit Systems, Inc, signed and sealed by Scott Wolters, P.E., bearing the Miami-Dade County Product Control revision stamp with the Notice of Acceptance number and expiration date by the Miami-Dade County Product Control Section.

MISSILE IMPACT RATING: Large and Small Missile Impact Resistant.

LABELING: Each unit shall bear a permanent label with the manufacturer's name or logo, city, state and following statement: "Miami-Dade County Product Control Approved", unless otherwise noted herein. Each container (bucket or drum) needs to be labeled. Unit is further defined as each roll of reinforcing mesh.

RENEWAL of this NOA shall be considered after a renewal application has been filed and there has been no change in the applicable building code negatively affecting the performance of this product.

TERMINATION of this NOA will occur after the expiration date or if there has been a revision or change in the materials, use, and/or manufacture of the product or process. Misuse of this NOA as an endorsement of any product, for sales, advertising or any other purposes shall automatically terminate this NOA. Failure to comply with any section of this NOA shall be cause for termination and removal of NOA.

ADVERTISEMENT: The NOA number preceded by the words Miami-Dade County, Florida, and followed by the expiration date may be displayed in advertising literature. If any portion of the NOA is displayed, then it shall be done in its entirety.

INSPECTION: A copy of this entire NOA shall be provided to the user by the manufacturer or its distributors and shall be available for inspection at the job site at the request of the Building Official. This NOA revises **NOA # 17-0807.13** and consists of this page 1 and evidence pages E-1, E-2 and E-3, as well as approval document mentioned above.

The submitted documentation was reviewed by **Ishaq I. Chanda, P.E.**



Ishaq I. Chanda

NOA No. 21-0521.07
Expiration Date: August 15, 2022
Approval Date: July 08, 2021
Page 1

NOTICE OF ACCEPTANCE: EVIDENCE SUBMITTED

1. EVIDENCE SUBMITTED UNDER PREVIOUS NOAs

A. DRAWINGS “Submitted under NOA # 10-0209.11”

1. Drawing No. **OSOPLCONCBLK**, titled “Outsulation System or Outsulation Plus MD System over Concrete or Concrete Block”, sheets 1 through 3 of 3, dated 10/08/2009, prepared by Dryvit Systems, Inc, signed and sealed by Scott Wolters, P.E.

B. TESTS “Submitted under NOA # 10-0209.11”

1. Test reports on 1) Air Infiltration Test, per FBC, TAS 202-94
2) Uniform Static Air Pressure Test, Loading per FBC TAS 202-94
3) Water Resistance Test, per FBC, TAS 202-94
4) Cyclic Wind Pressure Loading per FBC, TAS 203-94
along with marked-up drawings and installation diagram of Dryvit Outsulation Plus MD System over Concrete Masonry, prepared by Hurricane Test Laboratory, LLC, Test Report No. **G387-0701-09**, dated 12/01/2009, signed and sealed by Vinu J. Abraham, P.E.

“Submitted under NOA # 08-0729.13”

2. Test report on Tensile Bond per ASTM C297 of Dryvit Primus (P) Mixture to Various Substrates, prepared by ETC Laboratories, Test Report No. **ETC-06-1059-18353.1**, dated 12/01/2006, signed and sealed by Joseph L. Doldan, P.E.
3. Test report on Tensile Bond per ASTM C297 of Dryvit Primus (P) Mixture to Dryvit Backstop NT, prepared by ETC Laboratories, Test Report No. **ETC-06-1059-18354.1**, dated 12/05/2006, signed and sealed by Joseph L. Doldan, P.E.
4. Test report on Tensile Bond per ASTM C297 of Dryvit Genesis (G) Mixture to Various Substrates, prepared by ETC Laboratories, Test Report No. **ETC-06-1059-18355.1**, dated 12/01/2006, signed and sealed by Joseph L. Doldan, P.E.
5. Test report on Tensile Bond per ASTM C297 of Dryvit Genesis (G) Mixture to Dryvit Backstop NT, prepared by ETC Laboratories, Test Report No. **ETC-06-1059-18356.1**, dated 12/05/2006, signed and sealed by Joseph L. Doldan, P.E.
6. Test report on Tensile Bond per ASTM C297 of Dryvit Genesis DM (GDM) Mixture to Various Substrates, prepared by ETC Laboratories, Test Report No. **ETC-06-1059-18357.1**, dated 12/05/2006, signed and sealed by Joseph L. Doldan, P.E.

“Submitted under NOA # 08-0729.13”

7. Test report on Tensile Bond per ASTM C297 of Dryvit Genesis (DM) to Dryvit Backstop NT to Various Substrates, prepared by ETC Laboratories, Test Report No. **ETC-06-1059-18358.1**, dated 12/05/2006, signed and sealed by Joseph L. Doldan, P.E.
8. Test report on Tensile Bond per ASTM C297 of Dryvit Backstop NT to Various Substrates, prepared by ETC Laboratories, Test Report No. **ETC-06-1059-18360.1**, dated 12/05/2006, signed and sealed by Joseph L. Doldan, P.E.

Ishaq I. Chanda

Ishaq I. Chanda, P.E.
Product Control Unit Supervisor
NOA No. 21-0521.07
Expiration Date: August 15, 2022
Approval Date: July 08, 2021

Dryvit Systems, Inc.

NOTICE OF ACCEPTANCE: EVIDENCE SUBMITTED

C. CALCULATIONS

1. None.

D. QUALITY ASSURANCE

1. Miami-Dade Department of Regulatory and Economic Resources (RER)

E. MATERIAL CERTIFICATIONS

1. None.

F. STATEMENTS “Submitted under NOA # 15-0929.20”

1. Statement letter of code conformance to the 5th edition (2014) FBC issued by Wolters Engineering, dated 09/10/2015, signed and sealed by Scott Wolters, P.E.

“Submitted under NOA # 12-0703.03”

2. Statement letter of code conformance to 2010 FBC issued by Wolters Engineering, dated 06/27/2012, signed and sealed by Scott Wolters, P.E.

2. EVIDENCE SUBMITTED UNDER PREVIOUS NOAs

A. DRAWINGS

1. None.

B. TESTS

1. None.

C. CALCULATIONS

1. None.

D. QUALITY ASSURANCE

1. Miami-Dade Department of Regulatory and Economic Resources (RER)

E. MATERIAL CERTIFICATIONS

1. None.

F. STATEMENTS

1. Statement letter of code conformance to the 6th Edition (2017) FBC issued by Wolters Engineering, dated 07/12/2017, signed and sealed by Scott Wolters, P.E.

Ishaq I. Chanda

Ishaq I. Chanda, P.E.
Product Control Unit Supervisor
NOA No. 21-0521.07
Expiration Date: August 15, 2022
Approval Date: July 08, 2021

NOTICE OF ACCEPTANCE: EVIDENCE SUBMITTED

3. NEW EVIDENCE SUBMITTED

A. DRAWINGS

1. Drawing No. **OSOPLCONCBLK**, titled “Outsulation System or Outsulation Plus MD System over Concrete or Concrete Block”, sheets 1 through 3 of 3, dated 10/08/2009, prepared by Dryvit Systems, Inc, signed and sealed by Scott Wolters, P.E.

B. TESTS

1. None.

C. CALCULATIONS

1. None.

D. QUALITY ASSURANCE

1. Miami-Dade Department of Regulatory and Economic Resources (RER)

E. MATERIAL CERTIFICATIONS

1. None.

F. STATEMENTS

1. Statement letter of code conformance to the 7th Edition (2020) FBC issued by Wolters Engineering, dated May 10, 2021, signed and sealed by Scott Wolters, P.E.

G. OTHER

1. This NOA revises NOA # 17-0807.13, expiring 08/15/2022.

Ishaq I. Chanda

Ishaq I. Chanda, P.E.
Product Control Unit Supervisor
NOA No. 21-0521.07
Expiration Date: August 15, 2022
Approval Date: July 08, 2021

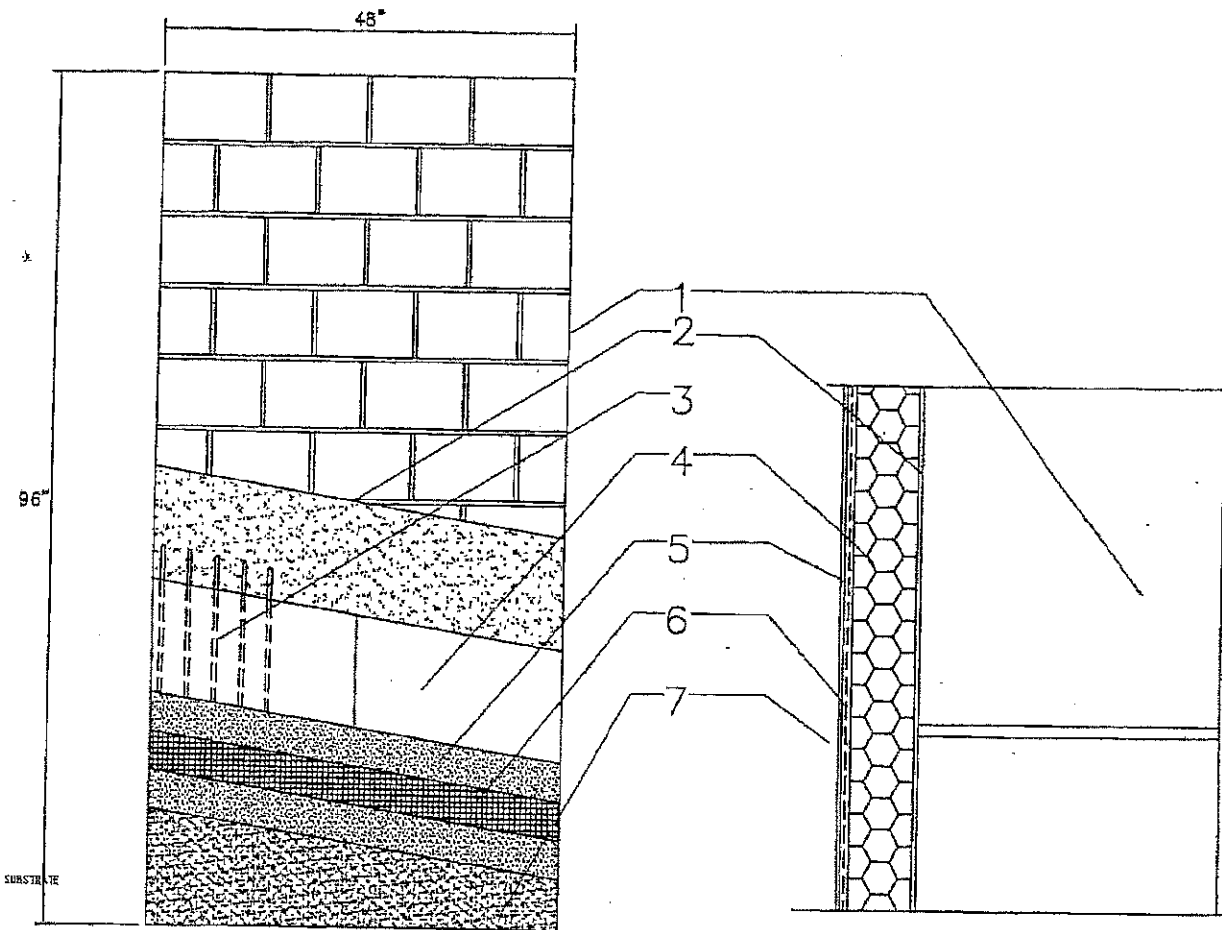

MATERIAL LIST

- ① CONCRETE WALL (ACI 318) CONCRETE MASONRY STRUCTURE (ASTM C90) AND TYPE S MORTAR (ASTM C270) COMPLYING WITH S.F.B.C.
- ② DRYVIT BACKSTOP® NT REQUIRED FOR OUTSULATION PLUS MD SYSTEM
- ③ ADHERE THE EXPANDED POLYSTYRENE (EPS) INSULATION BOARD WITH DRYVIT'S PRIMUS®, GENESIS® OR GENESIS® DM MIXTURE. PRIMUS IS AN ACRYLIC MODIFIED PRODUCT AND GENESIS IS AN ACRYLIC MODIFIED FIBER REINFORCED BASED PRODUCT. THEY ARE MIXED 1:1 BY WEIGHT WITH PORTLAND CEMENT AND WATER. GENESIS DM IS A DRYMIX POLYMER MODIFIED CEMENTITIOUS FIBER REINFORCED MATERIAL WHICH IS MIXED WITH WATER. THE ADHESIVE IS APPLIED WITH A 3/8" X 1/2" NOTCHED TROWEL WITH NOTCHES SPACED A MAXIMUM OF 1 1/2" O.C. THE ADHESIVE SHALL BE APPLIED TO THE BACK OF THE INSULATION BOARD SO THAT THE BEADS RUN VERTICALLY WHEN THE INSULATION BOARD IS PLACED ON THE WALL
- ④ MINIMUM 1" THICK INSULATION BOARD MEETING DRYVIT SPECIFICATION DS 131. INSULATION BOARD SUPPLIER SHALL POSSESS A CURRENT NOA WITH MIAMI DADE COUNTY
- ⑤ DRYVIT BASE COAT: PRIMUS®, GENESIS®, OR GENESIS® DM; PRIMUS OR GENESIS IS MIXED 1:1 BY WEIGHT WITH PORTLAND CEMENT AND WATER. PRIMUS AND GENESIS ARE 100 PERCENT ACRYLIC MODIFIED PRODUCTS. GENESIS DM IS A DRY MIX THAT IS MIXED WITH WATER
- ⑥ DRYVIT'S STANDARD REINFORCING MESH; 4.3 OZ/SQ. YD FIBERGLASS REINFORCING MESH EMBEDDED IN THE DRYVIT BASE COAT. THE STANDARD REINFORCING MESH SHALL BE LAPPED A MINIMUM OF 2 1/2" AT ALL EDGES.
- ⑦ DRYVIT FINISH: A 100 PERCENT ACRYLIC BASED MATERIAL AVAILABLE IN VARIOUS TEXTURES.

GENERAL NOTES

1. THE SYSTEM HAS BEEN DESIGNED IN ACCORDANCE WITH THE LATEST EDITION OF THE FLORIDA BUILDING CODE INCLUDING THE LATEST SUPPLEMENTS.
2. THIS SYSTEM SHALL BE APPLIED BY A LICENSED PLASTERING CONTRACTOR FOLLOWING THIS NOTICE OF ACCEPTANCE THE RECOMMENDATION OF DRYVIT SYSTEMS, INC. AND THE APPLICABLE SECTIONS OF THE FLORIDA BUILDING CODE.
3. THE ENGINEER AND/OR ARCHITECT OF RECORD FOR EACH PROJECT USING THE SYSTEM SHALL DESIGN THE CONCRETE OR BLOCK WALL TO ENSURE CONFORMANCE WITH ALL GOVERNING CODES AND THIS DOCUMENT
4. INSULATION BOARDS SHALL BE POSITIONED IN A RUNNING BOND PATTERN.
5. THE CONCRETE OR BLOCK WALL SURFACE SHALL BE DRY CLEAN AND FREE OF ALL LOOSE DEBRIS PRIOR TO PLACING THE SYSTEM
6. DETAILS ON SHEETS 2 AND 3 OF 3 ARE TYPICAL AND SHOW INTENT TO PREVENT WATER INFILTRATION INTO AND BEHIND THIS SYSTEM. ALTERNATE DETAILS AND SPECIFIC CONDITIONS NOT COVERED BY THE TYPICAL DETAILS ARE THE RESPONSIBILITY OF THE LICENSED DESIGN PROFESSIONALS

PRODUCT RENEWED
 as complying with the Florida
 Building Code
 Acceptance No. 12-0703.03
 Expiration Date 08/15/2017
 By *[Signature]*
 Miami-Dade Product Control

PRODUCT REVISED
 as complying with the Florida
 Building Code
 Acceptance No. 10-0249.11
 Expiration Date 08/15/2017
 By *[Signature]*
 Miami-Dade Product Control
 Division

DESIGN PRESSURE
±160 PSF

PRODUCT REVISED
 as complying with the Florida
 Building Code
 NOA-No. 21-0521.07
 Expiration Date 08/15/2022
 By *[Signature]*
 Miami-Dade Product Control

PRODUCT REVISED
 as complying with the Florida
 Building Code
 NOA-No. 17-0807.13
 Expiration Date 08/15/2022
 By *[Signature]*
 Miami-Dade Product Control

PRODUCT RENEWED
 as complying with the Florida
 Building Code
 NOA-No. 17-0531.03
 Expiration Date 08/15/2022
 By *[Signature]*
 Miami-Dade Product Control

PRODUCT REVISED
 as complying with the Florida
 Building Code
 Acceptance No. 15-0929.20
 Expiration Date 08/15/2017
 By *[Signature]*
 Miami-Dade Product Control

SCOTT WOLTERS
 FL PE# 62354
 WOLTERS ENGINEERING
 (COA# 27194)
 1271 GRANT STREET
 HOLLYWOOD, FL 33019
 PH/FAX: (954) 921-5828

SEAL: *[Signature]*
 1-15-10

DRYVIT SYSTEMS, INC. *dryvit®*
 One Energy Way
 West Warwick, Rhode Island
 DWG. NO.: 050PLCONCRBK
 SHEET NO: 1 OF 3
 ISSUE DATE: 10/08/09
 REV/DATE:
 OUTSULATION® SYSTEM OR OUTSULATION® PLUS MD SYSTEM® OVER CONCRETE OR CONCRETE BLOCK

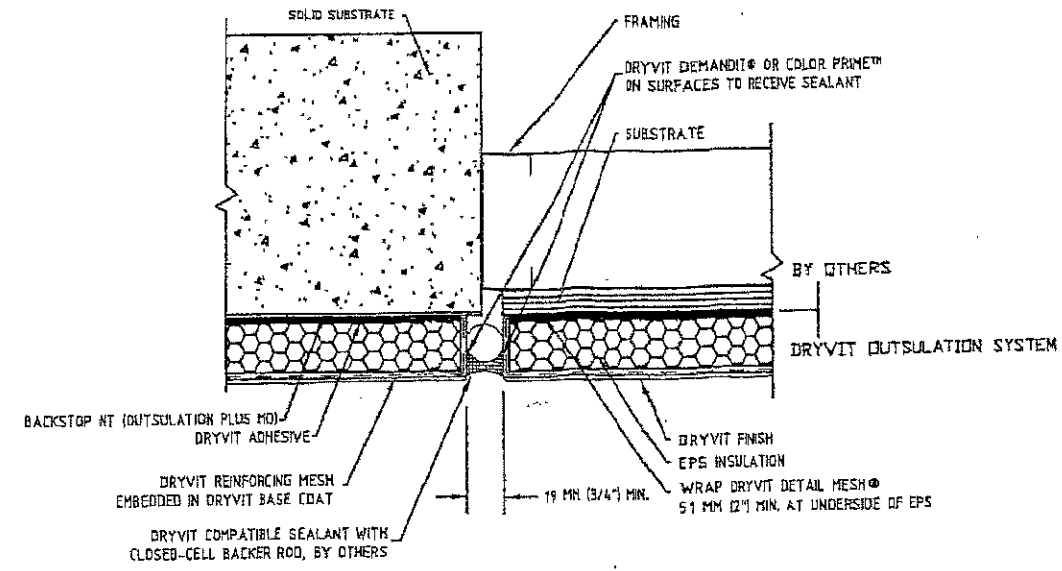

EXPANSION JOINT

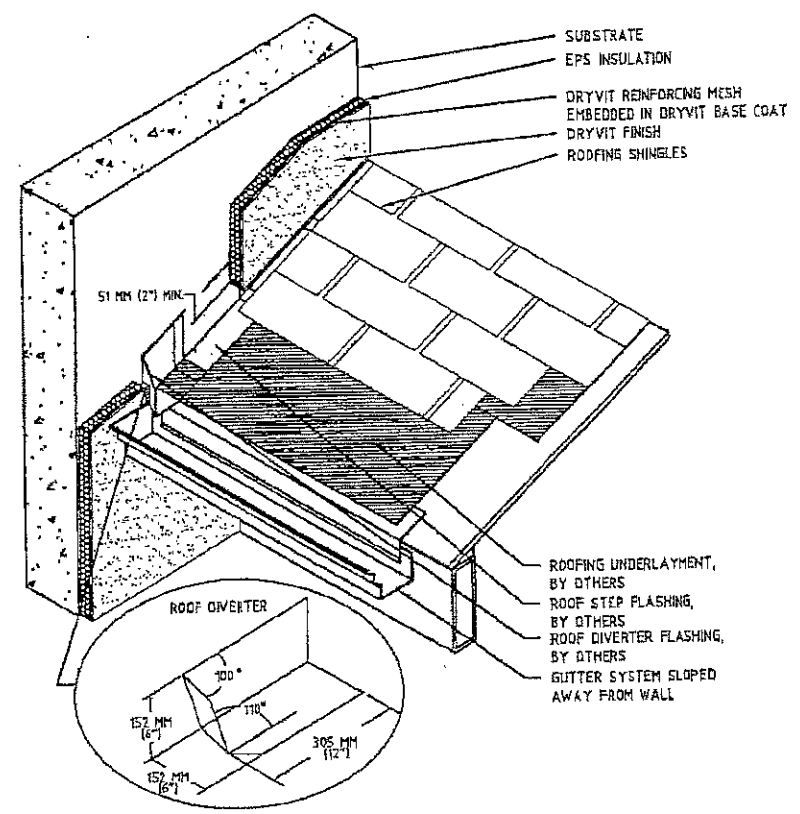

TERMINATION AT SLOPED ROOF

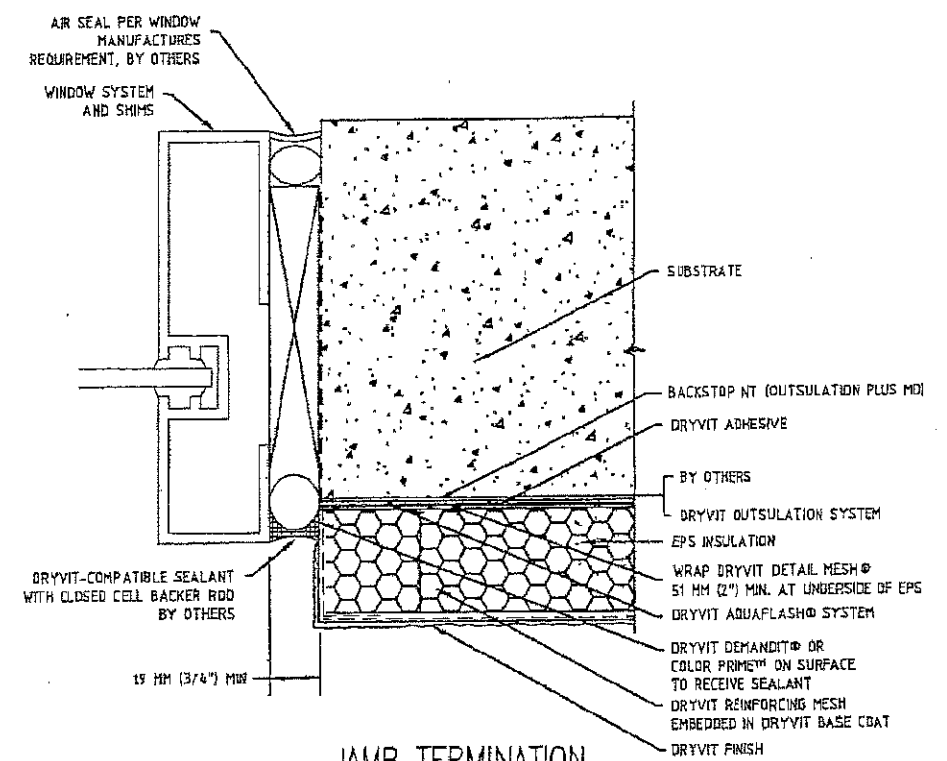

JAMB TERMINATION

PRODUCT RENEWED
 as complying with the Florida
 Building Code
 Acceptance No. 12-0703-03
 Expiration Date 08/15/2017
 By *[Signature]*
 Miami-Dade Product Control

PRODUCT REVISED
 as complying with the Florida
 Building Code
 Acceptance No. 10-0209-11
 Expiration Date 08/15/2012
 By *[Signature]*
 Miami-Dade Product Control
 Division

DESIGN PRESSURE
 ± 160 PSF

PRODUCT REVISED
 as complying with the Florida
 Building Code
 NOA-No. 21-0521.07
 Expiration Date 08/15/2022
 By *[Signature]*
 Miami-Dade Product Control

PRODUCT REVISED
 as complying with the Florida
 Building Code
 NOA-No. 17-0807.13
 Expiration Date 08/15/2022
 By *[Signature]*
 Miami-Dade Product Control

PRODUCT RENEWED
 as complying with the Florida
 Building Code
 NOA-No. 17-0531.03
 Expiration Date 08/15/2022
 By *[Signature]*
 Miami-Dade Product Control

PRODUCT REVISED
 as complying with the Florida
 Building Code
 Acceptance No. 15-0929-20
 Expiration Date 08/15/2017
 By *[Signature]*
 Miami-Dade Product Control

SCOTT WOLTERS
 FL-PE# 62354
 WOLTERS ENGINEERING
 (COA# 27194)
 1271 GRANT STREET
 HOLLYWOOD, FL 33019
 PH/FAX: (954) 921-5828
 SEAL: *[Signature]*
 1-15-10

DRYVIT SYSTEMS, INC. *[Logo]*
 One Energy Way
 West Warwick, Rhode Island
 DWG. NO.: OSOPLCONCBLK
 SHEET NO: 2 OF 3
 ISSUE DATE: 10/08/09
 REV/DATE:
 OUTSULATION SYSTEM OR OUTSULATION PLUS MD SYSTEM
 OVER CONCRETE OR CONCRETE BLOCK

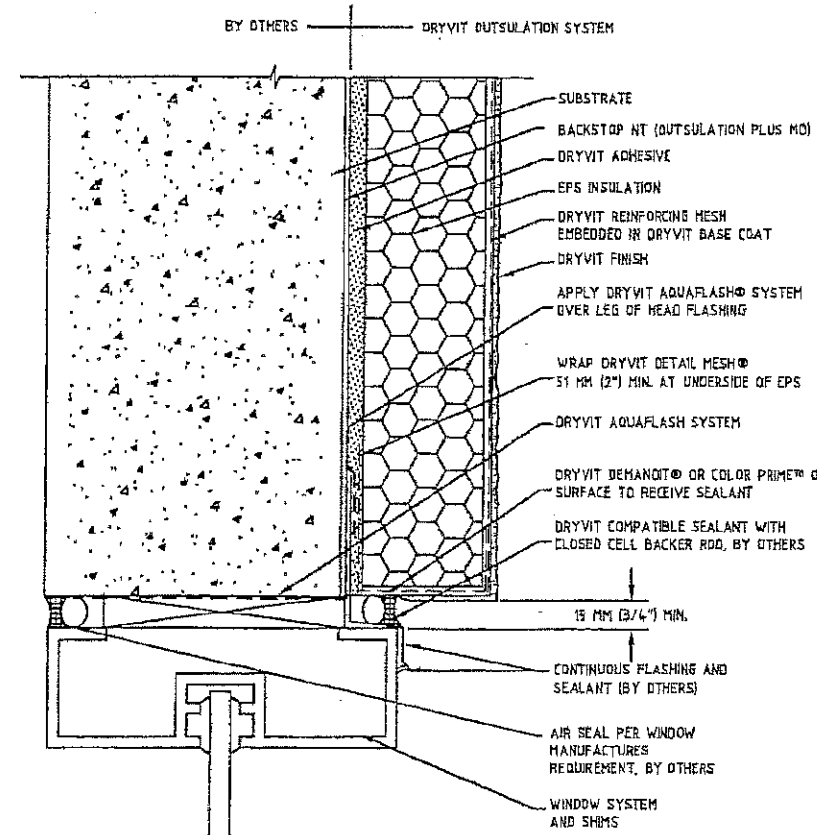

HEAD TERMINATION

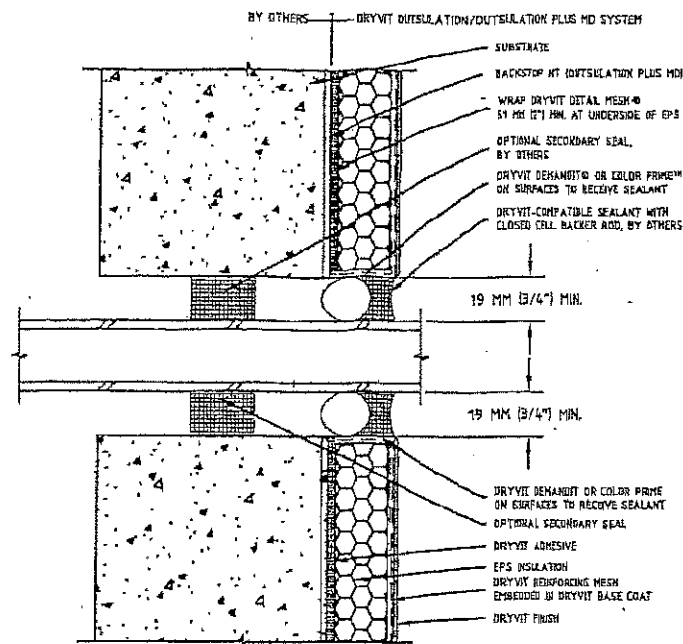

PENETRATIONS

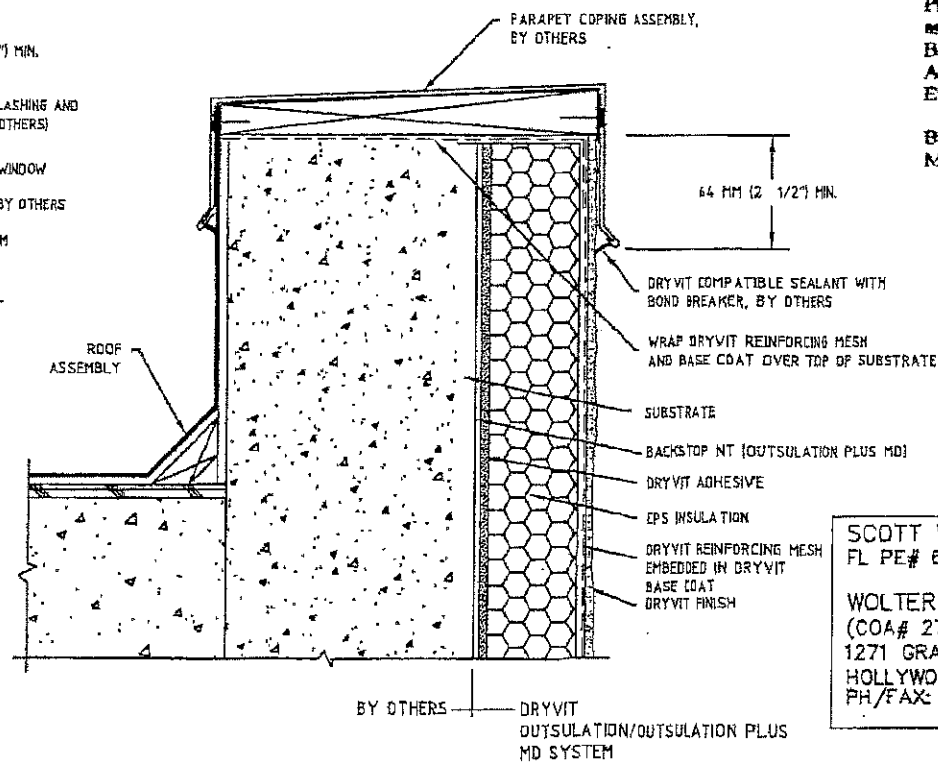

PARAPET

PRODUCT REVISED
as complying with the Florida Building Code
NOA-No. 17-0807.13
Expiration Date 08/15/2022
By [Signature]
Miami-Dade Product Control

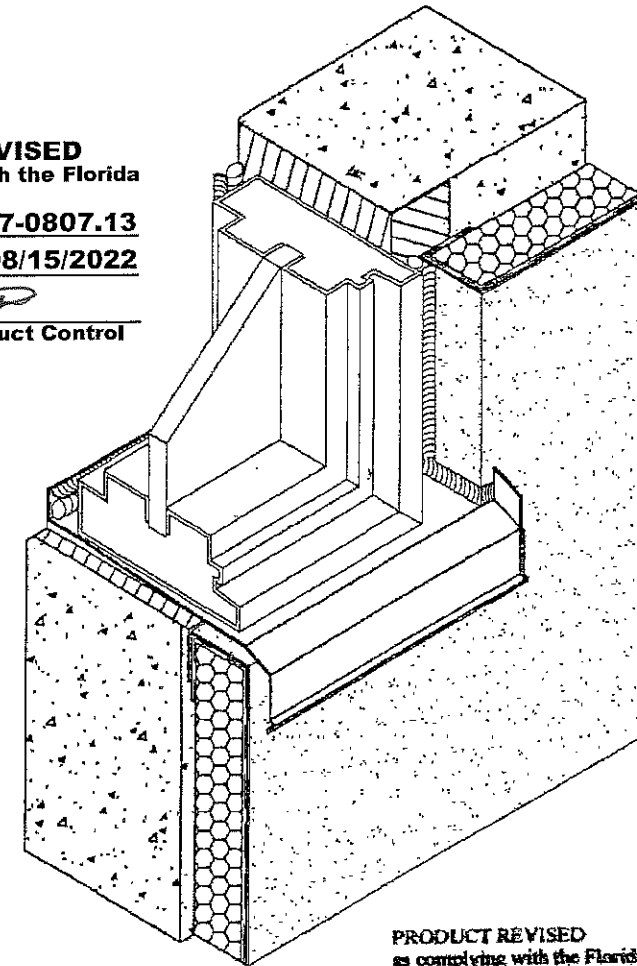

WINDOW OPENING

PRODUCT RENEWED
as complying with the Florida Building Code
Acceptance No. 12-0703.03
Expiration Date 03/15/2017
By [Signature]
Miami-Dade Product Control

PRODUCT REVISED
as complying with the Florida Building Code
Acceptance No. 15-0929.20
Expiration Date 08/15/2017
By [Signature]
Miami-Dade Product Control

PRODUCT REVISED
as complying with the Florida Building Code
Acceptance No. 10-0209.11
Expiration Date 08/15/2012
By [Signature]
Miami-Dade Product Control Division

DESIGN PRESSURE
± 160 PSF

PRODUCT REVISED
as complying with the Florida Building Code
NOA-No. 21-0521.07
Expiration Date 08/15/2022
By [Signature]
Miami-Dade Product Control

PRODUCT RENEWED
as complying with the Florida Building Code
NOA-No. 17-0531.03
Expiration Date 08/15/2022
By [Signature]
Miami-Dade Product Control

SCOTT WOLTERS
FL PE# 62354
WOLTERS ENGINEERING
(COA# 27194)
1271 GRANT STREET
HOLLYWOOD, FL 33019
PH/FAX: (954) 921-5628

SEAL: [Signature]
1-15-10

DRYVIT SYSTEMS, INC.
One Energy Way
West Warwick, Rhode Island
DWG. NO.: OSOPLCONCBLK

dryvit®

SHEET NO: 3 OF 3
ISSUE DATE: 10/08/09
REV. DATE: / /

OUTSULATION SYSTEM OR OUTSULATION PLUS MD SYSTEM OVER CONCRETE OR CONCRETE BLOCK