



DEPARTMENT OF REGULATORY AND ECONOMIC RESOURCES (RER)  
BOARD AND CODE ADMINISTRATION DIVISION  
**NOTICE OF ACCEPTANCE (NOA)**

MIAMI-DADE COUNTY  
PRODUCT CONTROL SECTION  
11805 SW 26 Street, Room 208  
Miami, Florida 33175-2474  
T (786) 315-2590 F (786) 315-2599  
[www.miamidade.gov/economy](http://www.miamidade.gov/economy)

**Dryvit Systems, Inc.**  
**One Energy Way**  
**West Warwick, RI 02893**

**SCOPE:** This NOA is being issued under the applicable rules and regulations governing the use of construction materials. The documentation submitted has been reviewed and accepted by Miami-Dade County RER-Product Control Section to be used in Miami Dade County and other areas where allowed by the Authority Having Jurisdiction (AHJ).

This NOA shall not be valid after the expiration date stated below. The Miami-Dade County Product Control Section (In Miami Dade County) and/or the AHJ (in areas other than Miami Dade County) reserve the right to have this product or material tested for quality assurance purposes. If this product or material fails to perform in the accepted manner, the manufacturer will incur the expense of such testing and the AHJ may immediately revoke, modify, or suspend the use of such product or material within their jurisdiction. RER reserves the right to revoke this acceptance, if it is determined by Miami-Dade County Product Control Section that this product or material fails to meet the requirements of the applicable building code.

This product is approved as described herein and has been designed to comply with the Florida Building Code, including the High Velocity Hurricane Zone.

**DESCRIPTION: Dryvit Outsulation with Standard Plus EIF System over 1/2" Gypsum Sheathing**

**APPROVAL DOCUMENT:** Drawing No. **OSLSM12STDPLUS**, titled "Outsulation with Std. Plus over 1/2" Sheathing", sheets 1 through 3 of 3, dated 08/25/2006, with revision 2 dated 09/06/2016, prepared by Dryvit Systems, Inc., signed and sealed by Scott Wolters, P.E., bearing the Miami-Dade County Product Control revision stamp with the Notice of Acceptance number and expiration date by the Miami-Dade County Product Control Section.

**MISSILE IMPACT RATING: Large and Small Missile Impact Resistant.**

**LABELING:** Each unit shall bear a permanent label with the manufacturer's name or logo, city, state and following statement: "Miami-Dade County Product Control Approved", unless otherwise noted herein. Each container (bucket or drum) needs to be labeled. Unit is further defined as each roll of reinforcing mesh.

**RENEWAL** of this NOA shall be considered after a renewal application has been filed and there has been no change in the applicable building code negatively affecting the performance of this product.

**TERMINATION** of this NOA will occur after the expiration date or if there has been a revision or change in the materials, use, and/or manufacture of the product or process. Misuse of this NOA as an endorsement of any product, for sales, advertising or any other purposes shall automatically terminate this NOA. Failure to comply with any section of this NOA shall be cause for termination and removal of NOA.

**ADVERTISEMENT:** The NOA number preceded by the words Miami-Dade County, Florida, and followed by the expiration date may be displayed in advertising literature. If any portion of the NOA is displayed, then it shall be done in its entirety.

**INSPECTION:** A copy of this entire NOA shall be provided to the user by the manufacturer or its distributors and shall be available for inspection at the job site at the request of the Building Official.

This NOA **revises & renews NOA #17-0807.14** and consists of this page 1 and evidence pages E-1, E-2 and E-3, as well as approval document mentioned above.

The submitted documentation was reviewed by **Ishaq I. Chanda, P.E.**



*Ishaq I. Chanda*

NOA No. 21-0521.08  
Expiration Date: September 17, 2022  
Approval Date: July 29, 2021  
Page 1

**NOTICE OF ACCEPTANCE: EVIDENCE SUBMITTED**

**1. EVIDENCE SUBMITTED UNDER PREVIOUS NOAs**

**A. DRAWINGS “Submitted under NOA # 16-0615.02”**

1. Drawing No. **OSLSM12STDPLUS**, titled “Outsulation with Std. Plus over ½” Sheathing”, sheets 1 through 3 of 3, dated 08/25/2006, with revision 2 dated 09/06/2016, prepared by Dryvit Systems, Inc., signed and sealed by Scott Wolters, P.E.

**B. TESTS “Submitted under NOA # 09-0824.10”**

1. Test reports on 1) Uniform Static Air Pressure Test, Loading per FBC TAS 202-94  
2) Large Missile Impact Test per FBC, TAS 201-94  
3) Cyclic Wind Pressure Loading per FBC, TAS 203-94  
along with marked-up drawings and installation diagram of Dryvit Outsulation System over ½” Sheathing, prepared by Hurricane Test Laboratory, LLC, Test Report No. **G141-0405-09**, dated 06/29/2009, signed and sealed by Vinu J. Abraham, P.E.

**“Submitted under NOA # 09-0824.10”**

2. Test reports on 1) Uniform Static Air Pressure Test, Loading per FBC TAS 202-94  
2) Large Missile Impact Test per FBC, TAS 201-94  
3) Cyclic Wind Pressure Loading per FBC, TAS 203-94  
along with marked-up drawings and installation diagram of Dryvit Outsulation System with Standard Plus over ½” Sheathing, prepared by Hurricane Test Laboratory, LLC, Test Report No. **G537-0302-09**, dated 06/24/2009, signed and sealed by Vinu J. Abraham, P.E.

**“Submitted under NOA # 06-0608.04”**

3. Test reports on 1) Air Infiltration Test, per FBC, TAS 202-94  
2) Uniform Static Air Pressure Test, Loading per FBC TAS 202-94  
3) Water Resistance Test, per FBC, TAS 202-94  
4) Large Missile Impact Test per FBC, TAS 201-94  
5) Cyclic Wind Pressure Loading per FBC, TAS 203-94  
along with marked-up drawings and installation diagram of “Exterior Insulation and Finish System”, prepared by ETC Laboratories, Test Report No. **ETC-06-1059-17956.0**, dated October 30, 2006, signed and sealed by Joseph Labora Doldan, P.E.

**“Submitted under NOA # 06-0608.04”**

4. Tensile Test Report per ASTM C297 on Primus & Genesis Products by Architectural Testing Inc., Test Report No. **01-30333.02**, dated 12/15/1997, signed and sealed by R. E. Kroll, P.E.

**C. CALCULATIONS “Submitted under NOA # 09-0824.10”**

1. Anchor verification calculations prepared by Wolters Engineering, dated 08/10/2009, signed and sealed by Scott Wolters, P.E.

Ishaq I. Chanda

---

Ishaq I. Chanda, P.E.  
Product Control Unit Supervisor  
NOA No. 21-0521.08  
Expiration Date: September 17, 2022  
Approval Date: July 29, 2021

**NOTICE OF ACCEPTANCE: EVIDENCE SUBMITTED**

**D. QUALITY ASSURANCE**

1. Miami-Dade Department of Regulatory and Economic Resources (RER)

**E. MATERIAL CERTIFICATIONS**

1. None.

**F. STATEMENTS “Submitted under NOA # 16-0615.02”**

1. Statement letter of code conformance to the 5<sup>th</sup> edition (2014) FBC issued by Wolters Engineering, dated 06/01/2016, signed and sealed by Scott Wolters, P.E.

**“Submitted under NOA # 12-0312.04”**

2. Statement letter of code conformance to 2010 FBC issued by Wolters Engineering, dated 02/28/2012, signed and sealed by Scott Wolters, P.E.

**2. EVIDENCE SUBMITTED under previous approval**

**A. DRAWINGS**

1. None.

**B. TESTS**

1. None.

**C. CALCULATIONS**

1. None.

**D. QUALITY ASSURANCE**

1. Miami-Dade Department of Regulatory and Economic Resources (RER)

**E. MATERIAL CERTIFICATIONS**

1. None.

**F. STATEMENTS**

1. Statement letter of code conformance to the 6<sup>th</sup> Edition (2017) FBC issued by Wolters Engineering, dated 07/12/2017, signed and sealed by Scott Wolters, P.E.

Ishaq I. Chanda

---

Ishaq I. Chanda, P.E.  
Product Control Unit Supervisor  
NOA No. 21-0521.08  
Expiration Date: September 17, 2022  
Approval Date: July 29, 2021

**NOTICE OF ACCEPTANCE: EVIDENCE SUBMITTED**

**3. NEW EVIDENCE SUBMITTED**

**A. DRAWINGS**

1. Drawing No. **OSLSM12STDPLUS**, titled “Outsulation with Std. Plus over ½” Sheathing”, sheets 1 through 3 of 3, dated 08/25/2006, with revision 2 dated 09/06/2016, prepared by Dryvit Systems, Inc., signed and sealed by Scott Wolters, P.E.

**B. TESTS**

1. None.

**C. CALCULATIONS**

1. None.

**D. QUALITY ASSURANCE**

1. Miami-Dade Department of Regulatory and Economic Resources (RER)

**E. MATERIAL CERTIFICATIONS**

1. None.

**F. STATEMENTS**

1. Statement letter of code conformance to the FBC 2020(7<sup>th</sup> Edition) issued by Wolters Engineering, dated May 04, 2021, signed and sealed by Scott Wolters, P.E.
2. Statement dated July 02, 2021 issued by Intertek Lab of upcoming schedule test for DryVit EIF’s system, signed by Vicki McElwain.

**G. OTHER**

1. This NOA **revises & conditionally renews NOA # 17-0807.14**, expiring **09/17/22** with balance of regular renewal upon submittal of test.

*Ishaq I. Chanda*

---

**Ishaq I. Chanda, P.E.**  
**Product Control Unit Supervisor**  
**NOA No. 21-0521.08**  
**Expiration Date: September 17, 2022**  
**Approval Date: July 29, 2021**

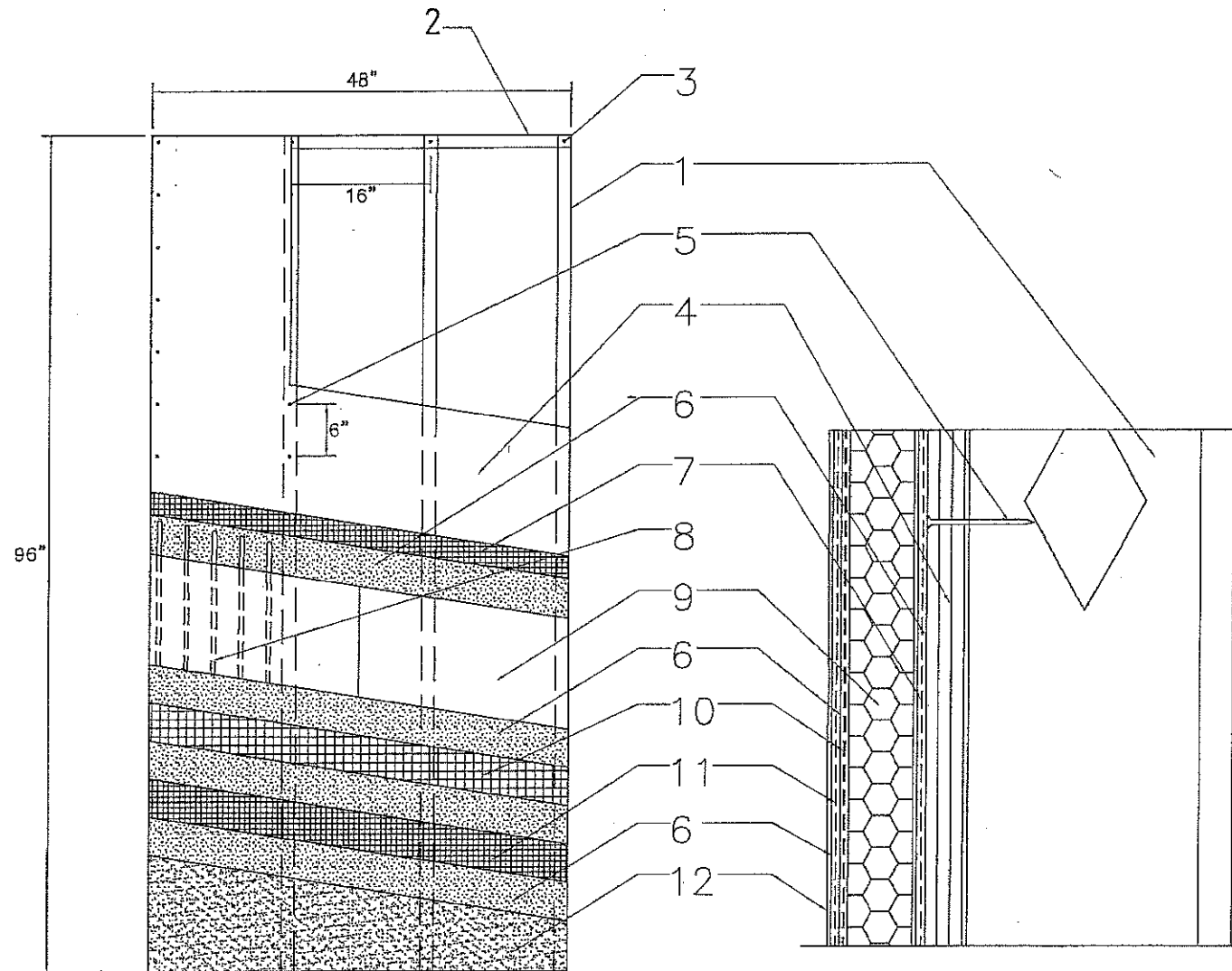

**MATERIAL LIST**

- ① MINIMUM 3 5/8" X 1 5/8" X 18 GAUGE STEEL STUDS AT 16" O.C.
- ② MINIMUM 3 5/8" X 18 GA. STEEL TRACK
- ③ MINIMUM 1/2 TEK SCREWS TO SECURE STEEL TRACK TO STEEL STUDS ON INTERIOR AND EXTERIOR
- ④ MINIMUM 1/2" EXTERIOR GRADE GYPSUM SHEATHING MEETING ASTM C 1396 (FORMALLY ASTM C 79) OR 1/2" DENS-GLASS GOLD, USG SECUROCK, OR NATIONAL GYPSUM e2XP SHEATHING, MEETING ASTM C 1177
- ⑤ MINIMUM NO. 8 x 1 5/8" WAFER HEAD SCREWS SPACED AT 6" O.C. ALONG VERTICAL STUDS
- ⑥ DRYVIT BASE COAT: PRIMUS®, GENESIS®, OR GENESIS® DM; PRIMUS OR GENESIS IS MIXED 1:1 BY WEIGHT WITH PORTLAND CEMENT AND WATER. PRIMUS AND GENESIS ARE 100 PERCENT POLYMER-BASED PRODUCTS. GENESIS DM IS A DRY MIX THAT IS MIXED WITH WATER
- ⑦ DRYVIT'S STANDARD PLUS REINFORCING MESH: 6 OZ/ SQ. YD. FIBERGLASS REINFORCING MESH EMBEDDED IN THE DRYVIT BASE COAT. THE STANDARD PLUS REINFORCING MESH SHALL BE LAPPED A MINIMUM OF 2 1/2" AT ALL EDGES
- ⑧ ADHERE THE EXPANDED POLYSTYRENE (EPS) INSULATION BOARD WITH DRYVIT'S PRIMUS, GENESIS OR GENESIS DM MIXTURE. THE ADHESIVE IS APPLIED WITH A 3/8" X 1/2" NOTCHED TROWEL WITH NOTCHES SPACED A MAXIMUM OF 1 1/2" O.C. THE ADHESIVE SHALL BE APPLIED TO THE BACK SIDE OF THE EPS IN A VERTICAL ORIENTATION
- ⑨ MINIMUM 1" THICK INSULATION BOARD MEETING THE FBC SECTION 2612. INSULATION BOARD SUPPLIER SHALL POSSESS A CURRENT NOA WITH MIAMI DADE COUNTY
- ⑩ DRYVIT PANZER® 20 REINFORCING MESH: 20.5 OZ/ SQ. YD. FIBERGLASS REINFORCING MESH EMBEDDED IN THE DRYVIT BASE COAT. PANZER 20 MESH EDGES SHALL BE ABUTTED TIGHTLY. DO NOT OVERLAP
- ⑪ DRYVIT'S STANDARD REINFORCING MESH: 4.3 OZ/SQ. YD FIBERGLASS REINFORCING MESH EMBEDDED IN THE DRYVIT BASE COAT. THE STANDARD REINFORCING MESH SHALL BE LAPPED A MINIMUM OF 2 1/2" AT ALL EDGES.
- ⑫ DRYVIT FINISH: A 100 PERCENT ACRYLIC BASED MATERIAL AVAILABLE IN VARIOUS TEXTURES.

**GENERAL NOTES**

- 1. THE SYSTEM HAS BEEN DESIGNED IN ACCORDANCE WITH THE LATEST EDITION OF THE FLORIDA BUILDING CODE INCLUDING THE LATEST SUPPLEMENTS.
- 2. THIS SYSTEM HAS BEEN TESTED IN ACCORDANCE WITH MIAMI DADE COUNTY PROTOCOLS TAS 201, TAS 202 AND TAS 203; IMPACT, STRUCTURAL AND CYCLIC TESTING
- 3. THIS SYSTEM SHALL BE APPLIED BY A LICENSED PLASTERING CONTRACTOR FOLLOWING THIS NOTICE OF ACCEPTANCE THE RECOMMENDATION OF DRYVIT SYSTEMS, INC. AND THE APPLICABLE SECTIONS OF THE FLORIDA BUILDING CODE.
- 4. THE ENGINEER AND/OR ARCHITECT OF RECORD FOR EACH PROJECT USING THIS SYSTEM SHALL SIZE ALL STUD FRAMING TO ENSURE CONFORMANCE WITH STUD DEFLECTION AND STRESS LIMITATIONS AS REQUIRED BY ALL GOVERNING CODES AND THIS DOCUMENT.
- 5. INSULATION BOARDS SHALL BE POSITIONED IN A RUNNING BOND PATTERN.
- 6. ALL STUDS USED WITH THIS SYSTEM SHALL BE COMPLETELY SHEATHED AT THE INTERIOR FLANGE OR BRIDGED AT A MAXIMUM OF EVERY 5' OF STUD LENGTH OR AS SPECIFIED BY THE STUD MANUFACTURER.
- 7. ALL STEEL STUDS SHALL BE STRUCTURAL WITH 1 5/8" MINIMUM FLANGE WIDTH AND HAVE A MINIMUM YIELD STRENGTH OF 33000 PSI.
- 8. DETAILS ON SHEETS 2 AND 3 OF 3 ARE TYPICAL AND SHOW INTENT TO PREVENT WATER INFILTRATION INTO AND BEHIND THIS SYSTEM. ALTERNATE DETAILS AND SPECIFIC CONDITIONS NOT COVERED BY THE TYPICAL DETAILS ARE THE RESPONSIBILITY OF THE LICENSED DESIGN PROFESSIONALS IN CONSULTATION WITH DRYVIT SYSTEMS, INC.

DESIGN PRESSURE
+/- 75.0 PSF

**PRODUCT REVISED**  
 as complying with the Florida  
 Building Code  
 NOA-No. 21-0521.08  
 Expiration Date 09/17/2022  
 By Ishag I. Chank  
 Miami-Dade Product Control

**PRODUCT REVISED**  
 as complying with the Florida  
 Building Code  
 NOA-No. 17-0807.14  
 Expiration Date 09/17/2021  
 By [Signature]  
 Miami-Dade Product Control

**PRODUCT RENEWED**  
 as complying with the Florida  
 Building Code  
 Acceptance No. 16-0615.02  
 Expiration Date 09/17/2021  
 By [Signature]  
 Miami-Dade Product Control

SCOTT WOLTERS  
 FL PE# 62354  
 WOLTERS ENGINEERING  
 (COA# 27194)  
 15211 97th ROAD N  
 WEST PALM BEACH, FL 33412  
 PH/FAX: (561) 225-1982

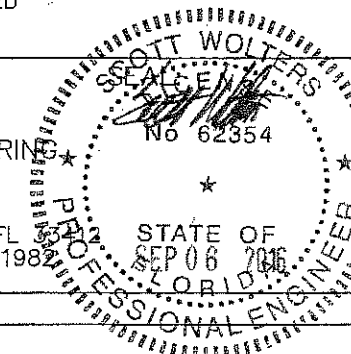

DRYVIT SYSTEMS, INC.

One Energy Way  
 West Warwick, Rhode Island

DWG. NO.: OSLSM12STDPLUS  
 SHEET NO: 1 OF 3  
 ISSUE DATE: 08/25/06  
 REV /2 09/06/16  
 OUTSULATION WITH STD. PLUS OVER 1/2" SHEATHING



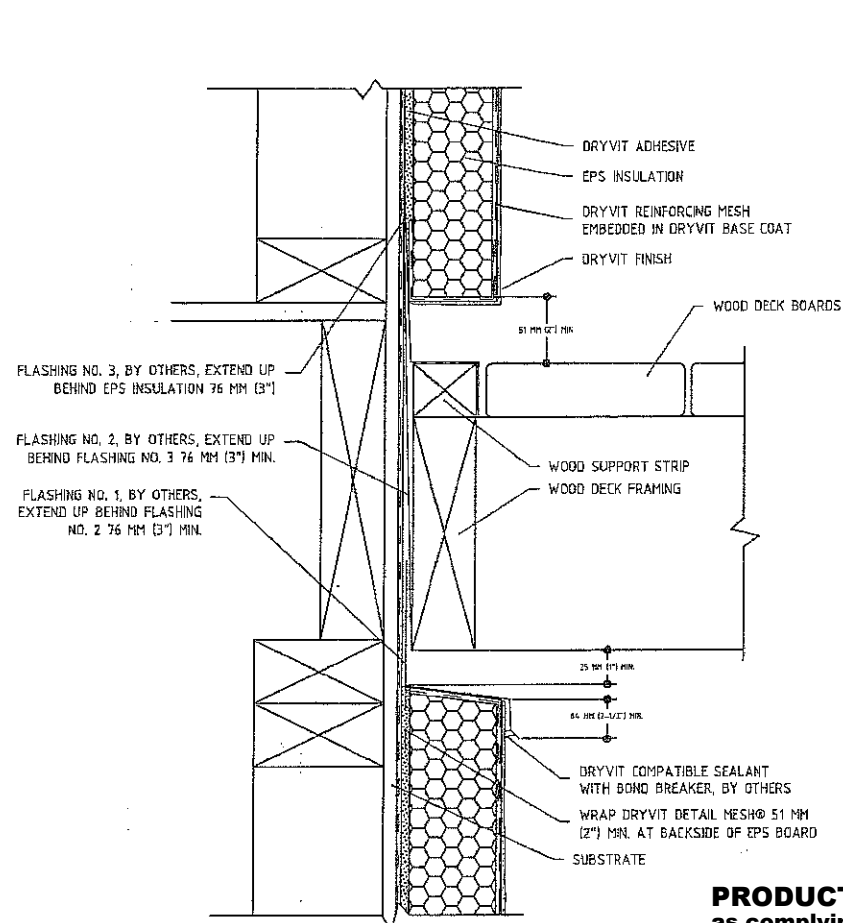

**PRODUCT REVISED**  
 as complying with the Florida  
 Building Code  
 NOA-No. 21-0521.08  
 Expiration Date 09/17/2022  
 By Ishag I. Chank  
 Miami-Dade Product Control

**Notes:**

1. Gap wood sheathing edge and end joints in accordance with APA (American Plywood Association) recommendations.
2. Seal Penetrations through flashing where attached to framing.
3. Distance of EIFS to deck varies with climate. Allow sufficient distance to prevent snow/ice and puddling water against system.
4. provide end dams where flashings terminate at ends of deck.
5. Pressure treated wood (space from flashing or rout backside to provide drainage)

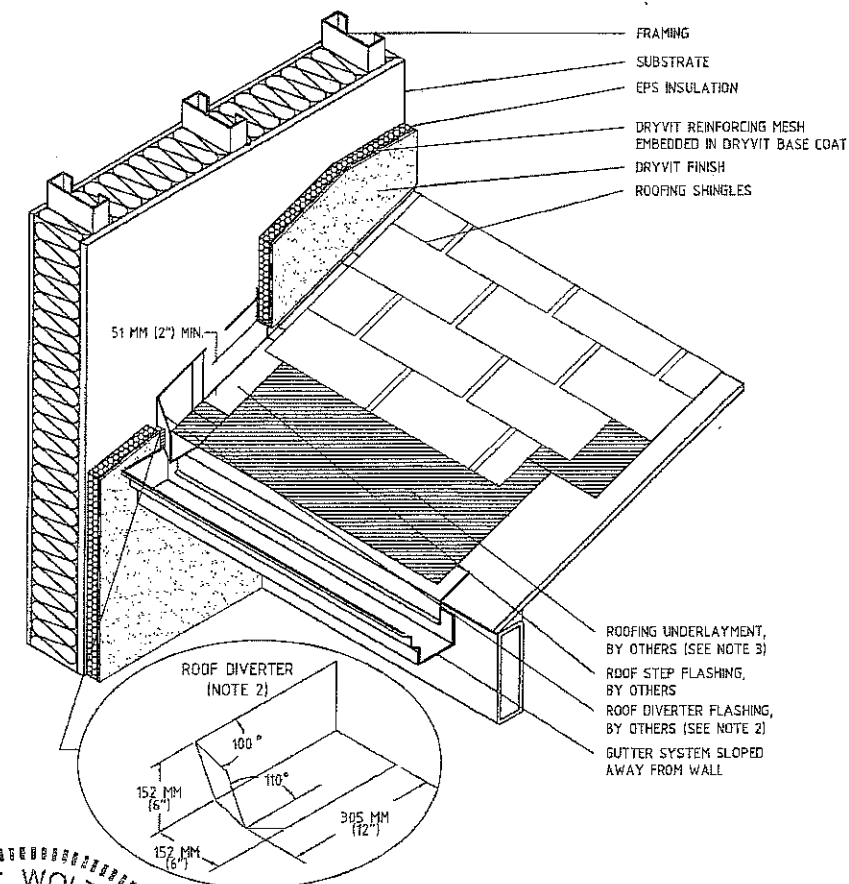
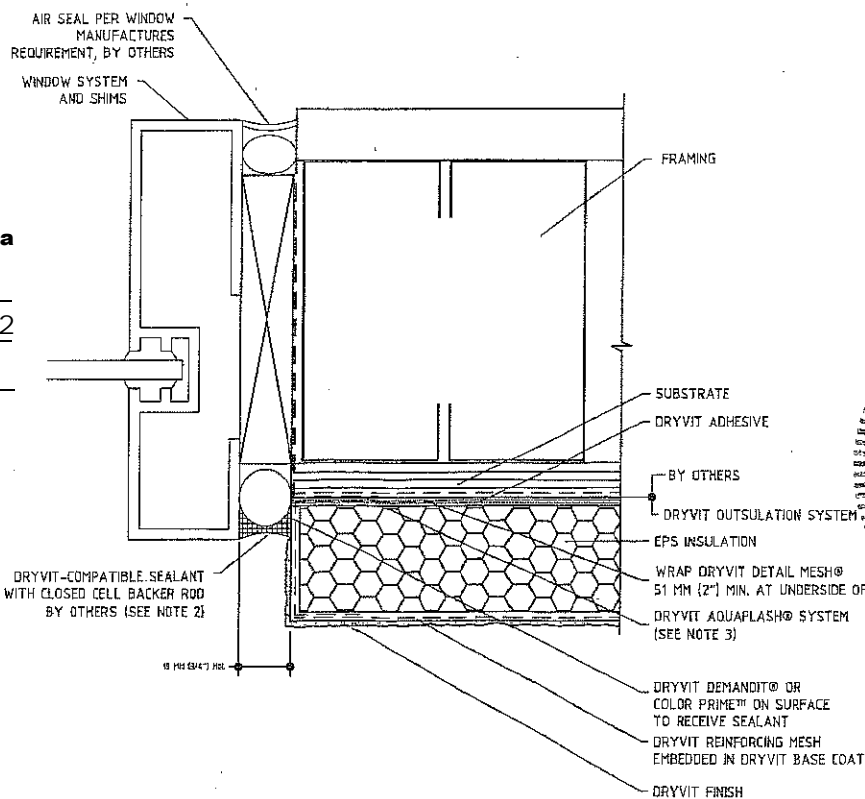
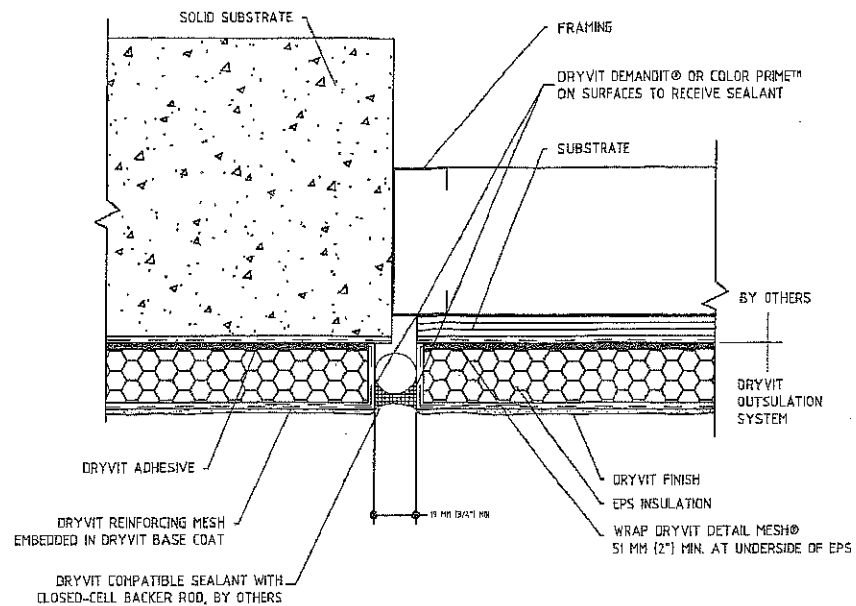

SCOTT WOLTERS  
 SEAL CENTER  
 No. 62354  
 STATE OF  
 FLORIDA  
 PROFESSIONAL ENGINEER  
 SEP 06 2016  
 SCOTT WOLTERS  
 FL PE# 82354

**PRODUCT RENEWED**  
 as complying with the Florida  
 Building Code  
 Acceptance No. 16-0615-02  
 Expiration Date 09/17/2021  
 By [Signature]  
 Miami-Dade Product Control

**PRODUCT REVISED**  
 as complying with the Florida  
 Building Code  
 NOA-No. 17-0807.14  
 Expiration Date 09/17/2021  
 By [Signature]  
 Miami-Dade Product Control

WOLTERS ENGINEERING  
 (COA# 27194)  
 15211 97th ROAD N  
 WEST PALM BEACH, FL 33412  
 PH/FAX: (561) 225-1982

DRYVIT SYSTEMS, INC.   
 One Energy Way  
 West Warwick, Rhode Island  
 DWG. NO.: OSLSM12STDPLUS  
 SHEET NO: 2 OF 3 | ISSUE DATE: 08/25/06 | REV /2 09/06/16  
 OUTSULATION WITH STD. PLUS OVER 1/2" SHEATHING

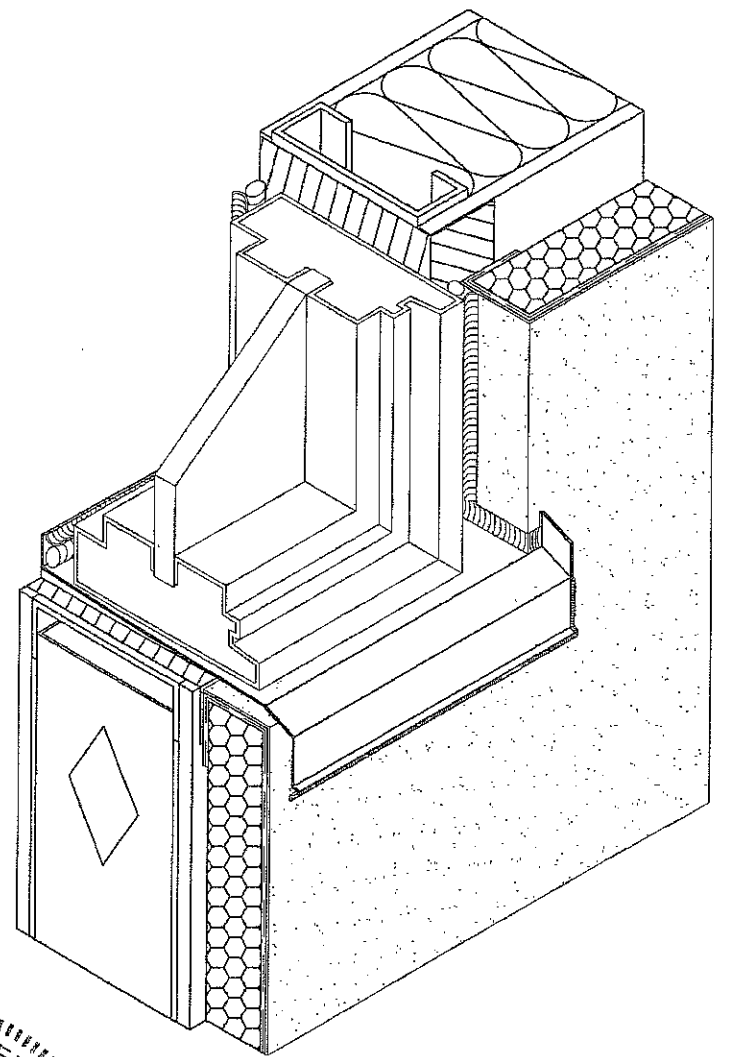
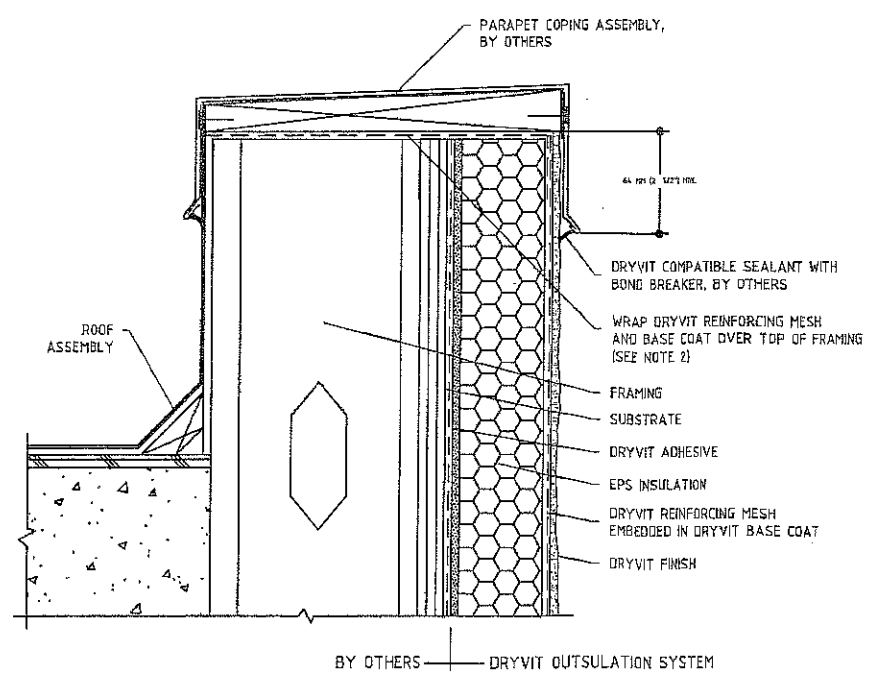
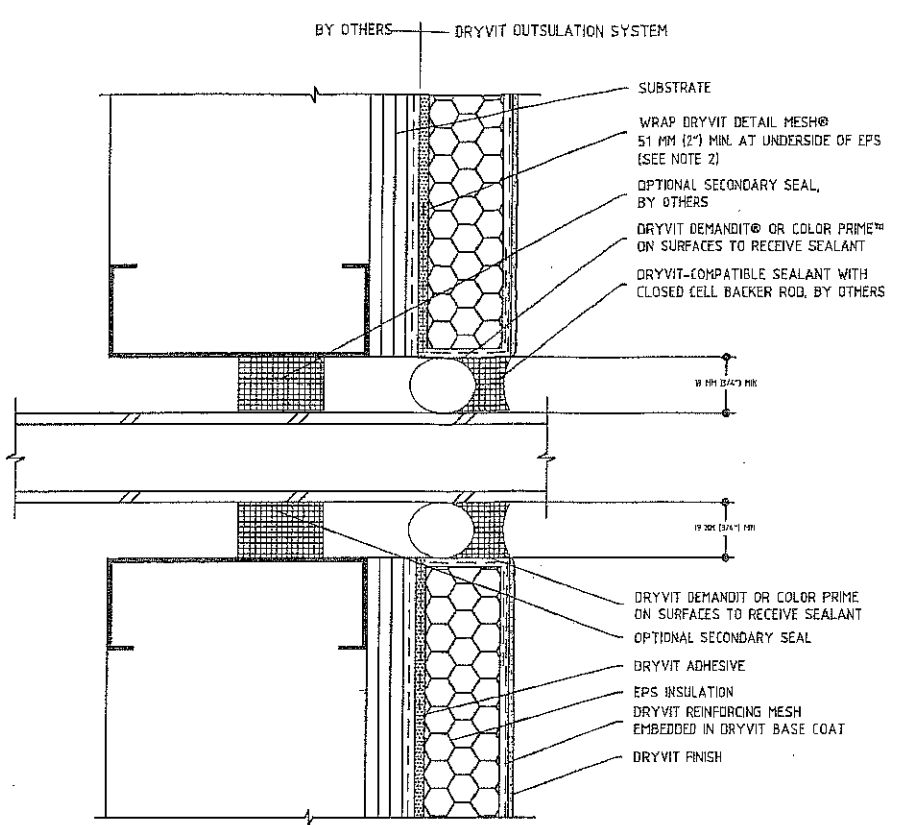
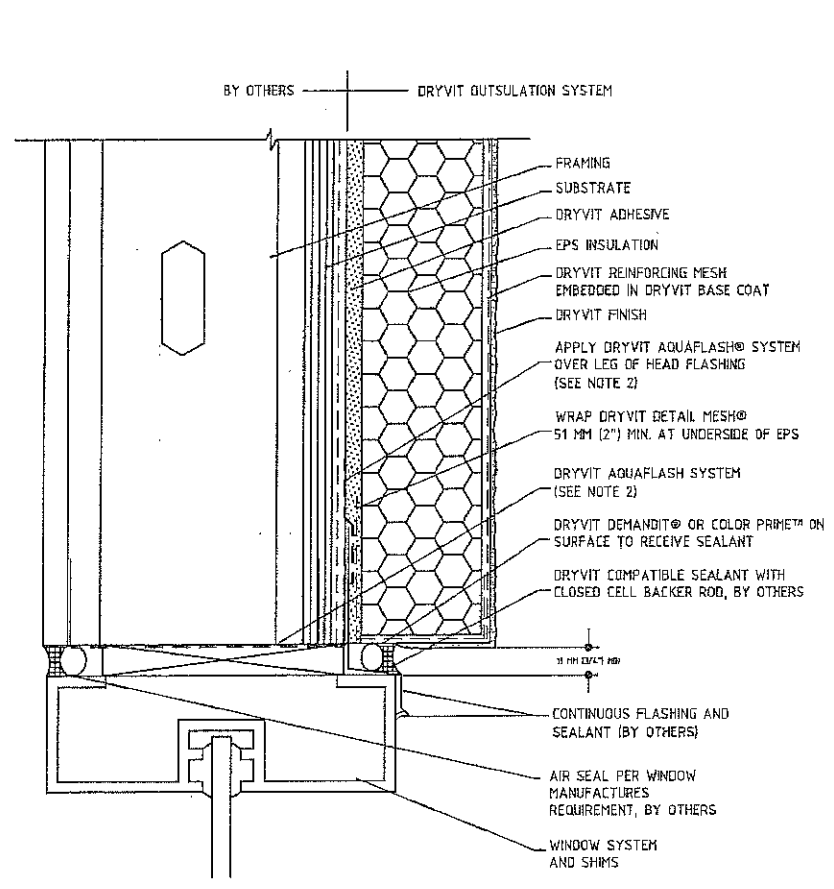

**PRODUCT REVISED**  
 as complying with the Florida  
 Building Code  
 NOA-No. 21-0521.08  
 Expiration Date 09/17/2022  
 By Ishtay I. Chandra  
 Miami-Dade Product Control

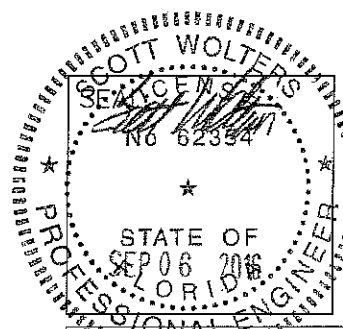

**PRODUCT RENEWED**  
 as complying with the Florida  
 Building Code  
 Acceptance No. 16-0615.02  
 Expiration Date 09/17/2021  
 By [Signature]  
 Miami-Dade Product Control

**PRODUCT REVISED**  
 as complying with the Florida  
 Building Code  
 NOA-No. 17-0807.14  
 Expiration Date 09/17/2021  
 By [Signature]  
 Miami-Dade Product Control

SCOTT WOLTERS  
 FL PE# 62354  
 WOLTERS ENGINEERING  
 (COA# 27194)  
 15211 97th ROAD N  
 WEST PALM BEACH, FL 33412  
 PH/FAX: (561) 225-1982

DRYVIT SYSTEMS, INC.  
 One Energy Way  
 West Warwick, Rhode Island  
 DWG. NO.: OLSM12STDPLUS  
 SHEET NO: 3 OF 3  
 ISSUE DATE: 08/25/06  
 REV /2 09/06/16  
 OUTSULATION WITH STD. PLUS OVER 1/2" SHEATHING