



DEPARTMENT OF REGULATORY AND ECONOMIC RESOURCES (RER)
BOARD AND CODE ADMINISTRATION DIVISION
NOTICE OF ACCEPTANCE (NOA)

MIAMI-DADE COUNTY
PRODUCT CONTROL SECTION
11805 SW 26 Street, Room 208
Miami, Florida 33175-2474
T (786) 315-2590 F (786) 315-2599
www.miamidade.gov/economy

Dryvit Systems, Inc.
One Energy Way
West Warwick, RI 02893

SCOPE: This NOA is being issued under the applicable rules and regulations governing the use of construction materials. The documentation submitted has been reviewed and accepted by Miami-Dade County RER-Product Control Section to be used in Miami-Dade County and other areas where allowed by the Authority Having Jurisdiction (AHJ).

This NOA shall not be valid after the expiration date stated below. The Miami-Dade County Product Control Section (In Miami-Dade County) and/ or the AHJ (in areas other than Miami-Dade County) reserve the right to have this product or material tested for quality assurance purposes. If this product or material fails to perform in the accepted manner, the manufacturer will incur the expense of such testing and the AHJ may immediately revoke, modify, or suspend the use of such product or material within their jurisdiction. RER reserves the right to revoke this acceptance, if it is determined by Miami-Dade County Product Control Section that this product or material fails to meet the requirements of the applicable building code.

This product is approved as described herein and has been designed to comply with the Florida Building Code, including the High Velocity Hurricane Zone.

DESCRIPTION: Outsulation and Outsulation Plus MD EIF System over 5/8” Gypsum Sheathing

APPROVAL DOCUMENT: Drawing No. **OSOPL58SMI** and **OSOPLNGHI58**, titled “Outsulation/ Outsulation Plus MD System over ASTM C1177 Sheathing”, sheets 1 and 2 of 2, prepared by Dryvit Systems, Inc., dated 03/23/2012, with revision **1** dated 12/07/2017, signed and sealed by Scott Wolters, P.E., bearing the Miami-Dade County Product Control revision stamp with the Notice of Acceptance number and expiration date by the Miami-Dade County Product Control Section.

MISSILE IMPACT RATING: Small Missile Impact Resistant

LABELING: Each unit shall bear a permanent label with the manufacturer's name or logo, Columbus, GA and following statement: "Miami-Dade County Product Control Approved", unless otherwise noted herein. Each container (bucket or drum) needs to be labeled. Unit is further defined as each roll of reinforcing mesh.

RENEWAL of this NOA shall be considered after a renewal application has been filed and there has been no change in the applicable building code negatively affecting the performance of this product.

TERMINATION of this NOA will occur after the expiration date or if there has been a revision or change in the materials, use, and/ or manufacture of the product or process. Misuse of this NOA as an endorsement of any product, for sales, advertising or any other purposes shall automatically terminate this NOA. Failure to comply with any section of this NOA shall be cause for termination and removal of NOA.

ADVERTISEMENT: The NOA number preceded by the words Miami-Dade County, Florida, and followed by the expiration date may be displayed in advertising literature. If any portion of the NOA is displayed, then it shall be done in its entirety.

INSPECTION: A copy of this entire NOA shall be provided to the user by the manufacturer or its distributors and shall be available for inspection at the job site at the request of the Building Official.

This NOA **revises NOA # 18-0123.09** and consists of this page 1 and evidence pages E-1, E-2 and E-3, as well as approval document mentioned above.

The submitted documentation was reviewed by **Ishaq I. Chanda, P.E.**



Ishaq I. Chanda

NOA No. 21-0521.14
Expiration Date: February 28, 2023
Approval Date: July 08, 2021
Page 1

Dryvit Systems, Inc.

NOTICE OF ACCEPTANCE: EVIDENCE SUBMITTED

1. EVIDENCE SUBMITTED UNDER PREVIOUS NOA's

A. DRAWINGS “Submitted under NOA # 12-0628.11”

1. Drawing No. OSOPL58SMI and OSOPLNGHI58, titled “Outsulation/Outsulation Plus MD System over ASTM C1177 Sheathing”, sheets 1 and 2 of 2, prepared by Dryvit Systems, Inc., dated 03/23/2012, signed and sealed by Scott Wolters, P.E.

B. TESTS “Submitted under NOA # 12-0628.11”

1. Test reports on
 - 1) Air Infiltration Test, per FBC, TAS 202-94
 - 2) Uniform Static Air Pressure Test, Loading per FBC TAS 202-94
 - 3) Water Resistance Test, per FBC, TAS 202-94
 - 4) Small Missile Impact Test per FBC, TAS 201-94
 - 5) Cyclic Wind Pressure Loading per FBC, TAS 203-94along with marked-up drawings and installation diagram of Outsulation Plus MD with Georgia Pacific Dens Glass Gold Sheathing EIF System, prepared by Architectural Testing, Inc, Report No. **B6765.03-550-18**, dated 05/16/2012, signed and sealed by Vinu J. Abraham, P.E.

C. CALCULATIONS “Submitted under NOA # 12-0628.11”

1. Anchorage to stud's calculations prepared by Wolters Engineering, Inc, dated 06/20/2012, signed and sealed by Scott Wolters, P.E.

D. QUALITY ASSURANCE

1. Miami-Dade Department of Regulatory and Economic Resources (RER)

E. MATERIAL CERTIFICATIONS

1. None.

F. STATEMENTS “Submitted under NOA # 15-0929.19”

1. Statement letter of code conformance to the 5th edition (2014) FBC issued by Wolters Engineering, Inc, dated 09/10/2015, signed and sealed by Scott Wolters, P.E.

“Submitted under NOA # 12-0628.11”
2. No financial interest letter issued by Wolters Engineering, Inc, dated 06/20/2012, signed and sealed by Scott Wolters, P.E.

Ishaq I. Chanda

Ishaq I. Chanda, P.E.
Product Control Unit supervisor
NOA No. 21-0521.14
Expiration Date: February 28, 2023
Approval Date: July 08, 2021

Dryvit Systems, Inc.

NOTICE OF ACCEPTANCE: EVIDENCE SUBMITTED

2. EVIDENCE SUBMITTED under previous approval

A. DRAWINGS

1. Drawing No. OSOPL58SMI and OSOPLNGHI58, titled "Outsulation/ Outsulation Plus MD System over ASTM C1177 Sheathing", sheets 1 and 2 of 2, prepared by Dryvit Systems, Inc., dated 03/23/2012, with revision 1 dated 12/07/2017, signed and sealed by Scott Wolters, P.E.

B. TESTS

1. Test Report on Tensile Bond Adhesion Performance per ASTM C 297 of the Dryvit NewBrick adhered with Dryvit Primus to a Dryvit base coat, prepared by Radco, Inc., compliance letter and Test Report No. RAD-5896, dated 01/20/2017, signed by Michael L. Zieman, P.E.
2. Test Report on Tensile Bond Adhesion Performance per ASTM C 297 of the Dryvit NewBrick adhered with Dryvit Genesis to a Dryvit base coat, prepared by Radco, Inc., compliance letter and Test Report No. RAD-5891, dated 01/20/2017, signed by Michael L. Zieman, P.E.
3. Test Report on Tensile Bond Adhesion Performance per ASTM C 297 of the Dryvit NewBrick adhered with Dryvit Genesis DM to a Dryvit base coat, prepared by Radco, Inc., compliance letter and Test Report No. RAD-5898, dated 01/20/2017, signed by Michael L. Zieman, P.E.
4. Test Reports on Tensile Bond Adhesion Performance per ASTM C 297 of the Dryvit NewBrick adhered with AP adhesive to a Dryvit base coat, prepared by Dryvit Systems, Inc., compliance letter and Test Report No. ES.00.07.235, dated 11/22/2017, signed by Bill Preston.

C. CALCULATIONS

1. None.

D. QUALITY ASSURANCE

1. Miami-Dade Department of Regulatory and Economic Resources (RER)

E. MATERIAL CERTIFICATIONS

1. None.

F. STATEMENTS

1. Statement letter of code conformance to **FBC 6th Edition (2017)**, dated January 04, 2018, issued by Wolters Engineering, signed and sealed by Scott Wolters P.E.

Ishaq I. Chanda

Ishaq I. Chanda, P.E.
Product Control Unit supervisor
NOA No. 21-0521.14
Expiration Date: February 28, 2023
Approval Date: July 08, 2021

Dryvit Systems, Inc.

NOTICE OF ACCEPTANCE: EVIDENCE SUBMITTED

3. NEW EVIDENCE SUBMITTED

A. DRAWINGS

2. Drawing No. OSOPL58SMI and OSOPLNGHI58, titled “Outsulation/ Outsulation Plus MD System over ASTM C1177 Sheathing”, sheets 1 and 2 of 2, prepared by Dryvit Systems, Inc., dated 03/23/2012, with revision 1 dated 12/07/2017, signed and sealed by Scott Wolters, P.E.

B. TESTS

1. None.

C. CALCULATIONS

1. None.

D. QUALITY ASSURANCE

1. Miami-Dade Department of Regulatory and Economic Resources (RER)

E. MATERIAL CERTIFICATIONS

1. None.

F. STATEMENTS

1. Statement letter of code conformance to the 7th Edition (2020) FBC issued by Wolters Engineering, Inc, dated May 10, 2021, signed and sealed by Scott Wolters, P.E.

G. OTHER

1. This NOA revises NOA # # 18-0123.09, expiring 02/28/23.

Ishaq I. Chanda

Ishaq I. Chanda, P.E.
Product Control Unit supervisor
NOA No. 21-0521.14
Expiration Date: February 28, 2023
Approval Date: July 08, 2021

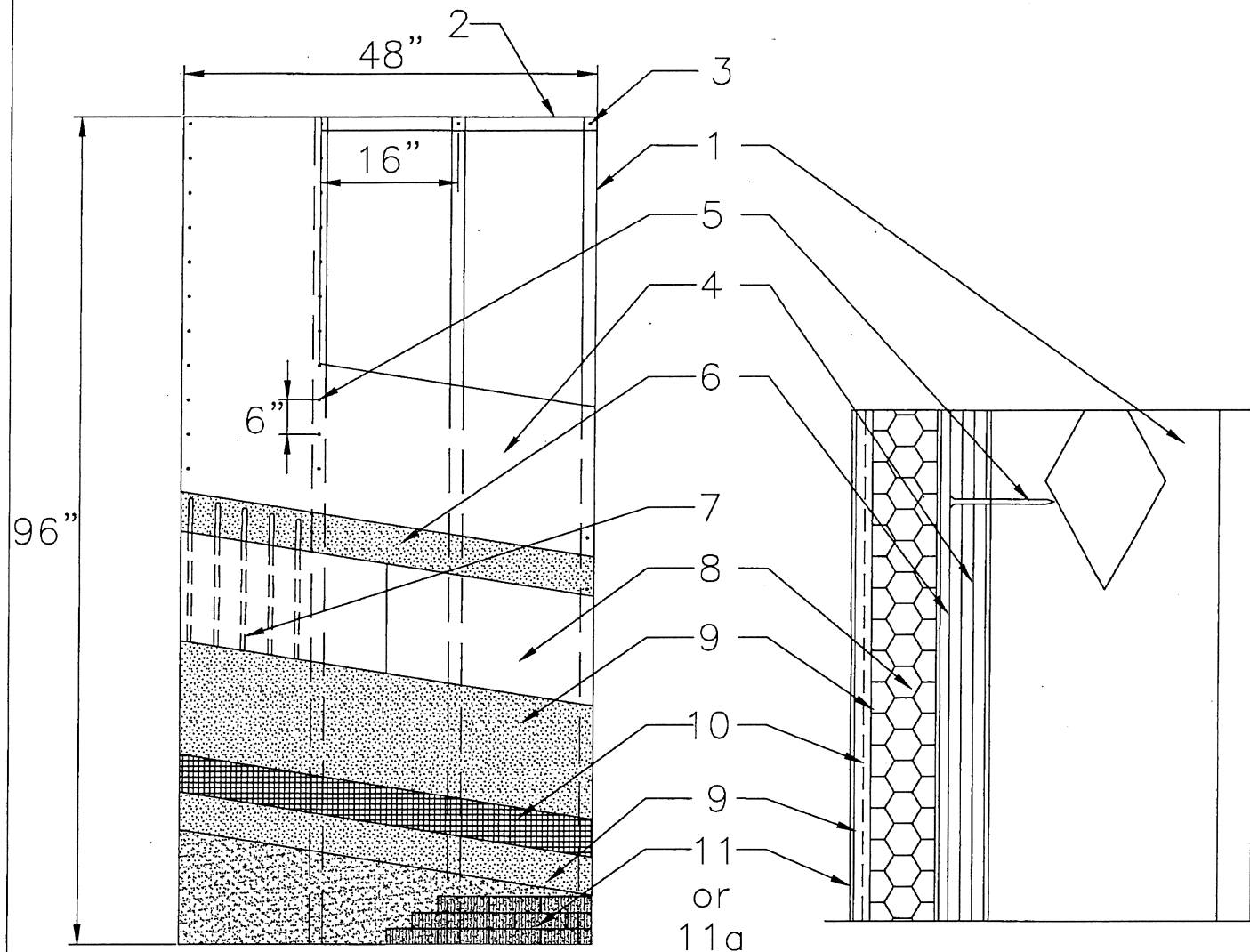

MATERIAL LIST

- ① 3 5/8" X 18 GAUGE STEEL STUDS AT 16" O.C.
- ② 3 5/8" X 18 GA. STEEL TRACK
- ③ MINIMUM 1/2" TEK SCREWS OR EQUIVALENT. TACK WELD IS ALSO ACCEPTABLE
- ④ MINIMUM 5/8" ASTM C 1177 SHEATHING
- ⑤ MINIMUM NO. 6 x 1 1/4" BUGLE HEAD SCREWS SPACED AT 6" O.C. ALONG VERTICAL STUDS
- ⑥ DRYVIT BACKSTOP NT REQUIRED FOR OUTSULATION PLUS MD SYSTEM ONLY
- ⑦ ADHERE THE EXPANDED POLYSTYRENE (EPS) INSULATION BOARD WITH DRYVIT'S PRIMUS, GENESIS OR GENESIS DM MIXTURE. THE ADHESIVE IS APPLIED WITH A 3/8" X 1/2" NOTCHED TROWEL WITH NOTCHES SPACED A MAXIMUM OF 1 1/2" O.C. THE ADHESIVE SHALL BE APPLIED TO THE BACK SIDE OF THE EPS IN A VERTICAL ORIENTATION
- ⑧ MINIMUM 1" THICK INSULATION BOARD MEETING THE FBC SECTION 2612. INSULATION BOARD SUPPLIER SHALL POSSESS A CURRENT NOA WITH MIAMI DADE COUNTY
- ⑨ DRYVIT BASE COAT: PRIMUS®, GENESIS®, OR GENESIS® DM; PRIMUS OR GENESIS IS MIXED 1:1 BY WEIGHT WITH PORTLAND CEMENT AND WATER. PRIMUS AND GENESIS ARE 100 PERCENT POLYMER-BASED PRODUCTS. GENESIS DM IS A DRY MIX THAT IS MIXED WITH WATER
- ⑩ DRYVIT'S STANDARD REINFORCING MESH: 4.3 OZ/SQ. YD FIBERGLASS REINFORCING MESH EMBEDDED IN THE DRYVIT BASE COAT. THE STANDARD REINFORCING MESH SHALL BE LAPPED A MINIMUM OF 2 1/2" AT ALL EDGES.
- ⑪ DRYVIT FINISH: A 100 PERCENT ACRYLIC BASED MATERIAL AVAILABLE IN VARIOUS TEXTURES; OR
- ⑪a DRYVIT NEWBRICK ADHERED TO BASE COAT WITH DRYVIT PRIMUS, GENESIS, GENESIS DM MIXTURE OR AP ADHESIVE.

GENERAL NOTES

- 1. THE SYSTEM HAS BEEN DESIGNED IN ACCORDANCE WITH THE LATEST EDITION OF THE FLORIDA BUILDING CODE INCLUDING THE LATEST SUPPLEMENTS.
- 2. THIS SYSTEM HAS BEEN TESTED IN ACCORDANCE WITH MIAMI DADE COUNTY PROTOCOLS TAS 201, TAS 202 AND TAS 203; IMPACT, STRUCTURAL AND CYCLIC TESTING.
- 3. THIS SYSTEM SHALL BE APPLIED BY A LICENSED PLASTERING CONTRACTOR FOLLOWING THIS NOTICE OF ACCEPTANCE THE RECOMMENDATION OF DRYVIT SYSTEMS, INC. AND THE APPLICABLE SECTIONS OF THE FLORIDA BUILDING CODE.
- 4. THE ENGINEER AND/OR ARCHITECT OF RECORD FOR EACH PROJECT USING THIS SYSTEM SHALL SIZE ALL STUD FRAMING TO ENSURE CONFORMANCE WITH STUD DEFLECTION AND STRESS LIMITATIONS AS REQUIRED BY ALL GOVERNING CODES AND THIS DOCUMENT.
- 5. INSULATION BOARDS SHALL BE POSITIONED IN A RUNNING BOND PATTERN.
- 6. ALL STUDS USED WITH THIS SYSTEM SHALL BE COMPLETELY SHEATHED AT THE INTERIOR FLANGE OR BRIDGED AT A MAXIMUM OF EVERY 5' OF STUD LENGTH OR AS SPECIFIED BY THE STUD MANUFACTURER.
- 7. ALL STEEL STUDS SHALL BE STRUCTURAL WITH 1 5/8" MINIMUM FLANGE WIDTH AND HAVE A MINIMUM YIELD STRENGTH OF 33000 PSI.
- 8. DETAILS ON SHEET 2 ARE TYPICAL AND SHOW INTENT TO PREVENT WATER INFILTRATION INTO AND BEHIND THIS SYSTEM. ALTERNATE DETAILS AND SPECIFIC CONDITIONS NOT COVERED BY THE TYPICAL DETAILS ARE THE RESPONSIBILITY OF THE LICENSED DESIGN PROFESSIONALS IN CONSULTATION WITH DRYVIT SYSTEMS, INC.

DESIGN PRESSURE
±93 psf

PRODUCT REVISED
as complying with the Florida Building Code
NOA-No. 21-0521.14
Expiration Date 02/28/2023
By *Ishtaq I. Chaudhry*
Miami-Dade Product Control

PRODUCT REVISED
as complying with the Florida Building Code
NOA-No. 18-0123.09
Expiration Date 02/28/2023
By *[Signature]*
Miami-Dade Product Control

SCOTT WOLTERS
FL PE# 62354
WOLTERS ENGINEERING
(COA# 27194)
15211 97th ROAD N
WEST PALM BEACH, FL 33412
PH/FAX: (561) 225-1982

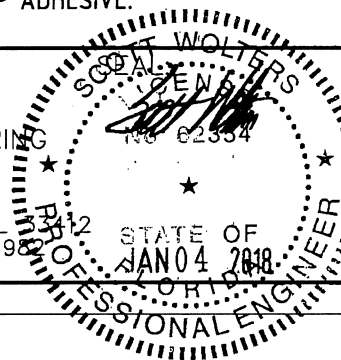

DRYVIT SYSTEMS, INC.

One Energy Way
West Warwick, Rhode Island

DWG. NO.: OSOPL58SMI

SHEET NO: 1 OF 2	ISSUE DATE: 08/29/08	REV /1 DATE 12/07/17
---------------------	-------------------------	-------------------------

OUTSULATION® SYSTEM OR OUTSULATION® PLUS MD SYSTEM® OVER ASTM C1177 SHEATHING

PRODUCT REVISED
 as complying with the Florida
 Building Code
 NOA-No. 21-0521.14
 Expiration Date 02/28/2023

By Ishag I. Chank
 Miami-Dade Product Control

PRODUCT REVISED
 as complying with the Florida
 Building Code
 NOA-No. 18-0123.09
 Expiration Date 02/28/2023
 By [Signature]
 Miami-Dade Product Control

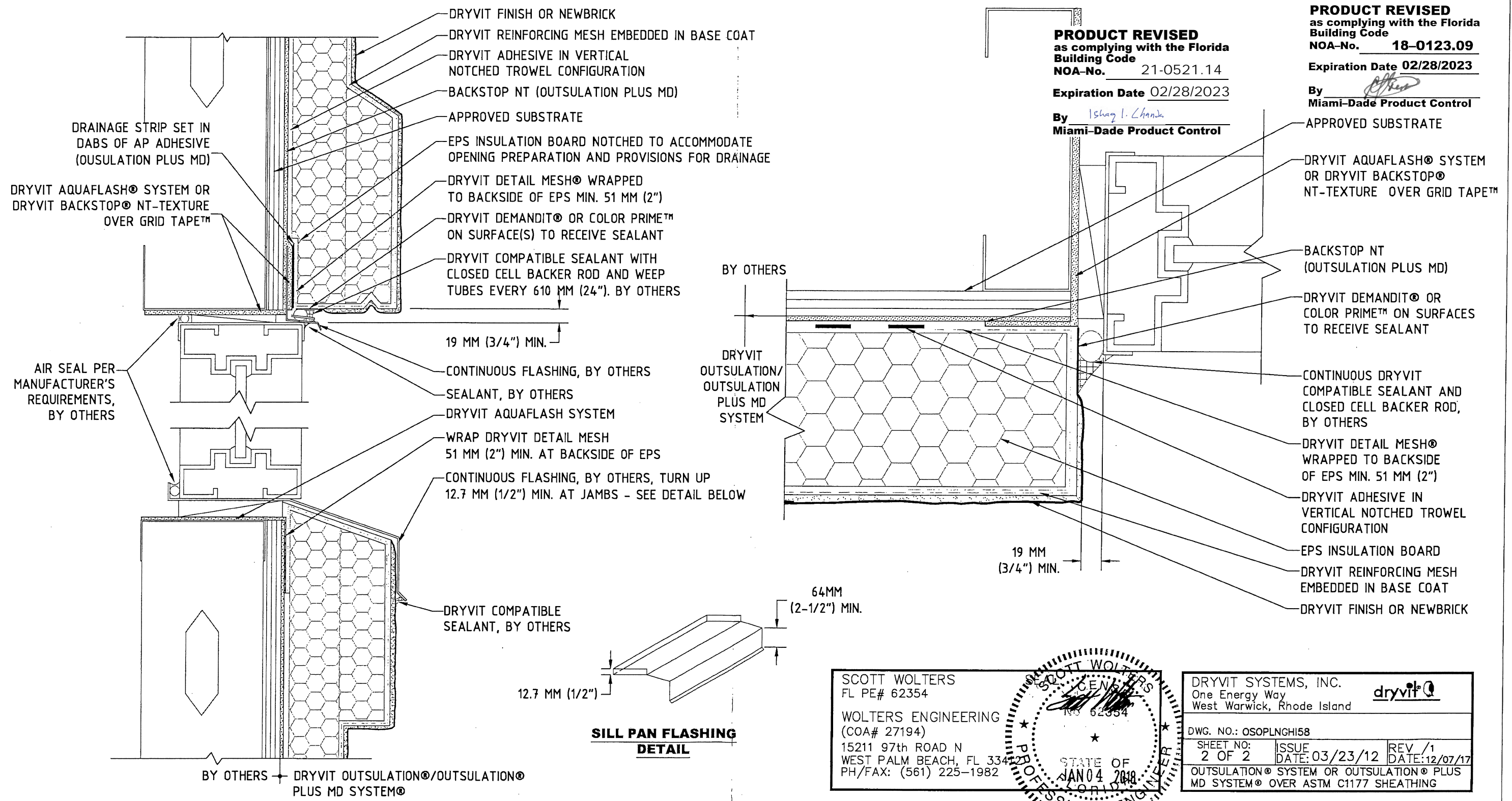

**SILL PAN FLASHING
 DETAIL**

SCOTT WOLTERS
 FL PE# 62354
 WOLTERS ENGINEERING
 (COA# 27194)
 15211 97th ROAD N
 WEST PALM BEACH, FL 33412
 PH/FAX: (561) 225-1982

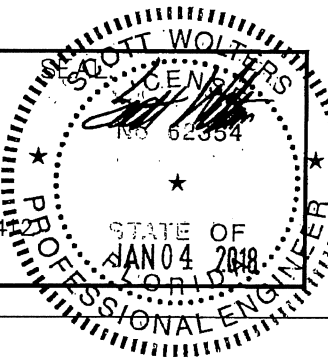

DRYVIT SYSTEMS, INC. One Energy Way West Warwick, Rhode Island			
DWG. NO.: OSOPLNGH158			
SHEET NO: 2 OF 2	ISSUE DATE: 03/23/12	REV. /1 DATE: 12/07/17	
OUTSULATION® SYSTEM OR OUTSULATION® PLUS MD SYSTEM® OVER ASTM C1177 SHEATHING			