



DEPARTMENT OF REGULATORY AND ECONOMIC RESOURCES (RER)  
BOARD AND CODE ADMINISTRATION DIVISION  
**NOTICE OF ACCEPTANCE (NOA)**

MIAMI-DADE COUNTY  
PRODUCT CONTROL SECTION  
11805 SW 26 Street, Room 208  
Miami, Florida 33175-2474  
T (786) 315-2590 F (786) 315-2599  
[www.miamidade.gov/building](http://www.miamidade.gov/building)

**CDM Impact System, Inc.**  
**8303 NW 27 Street, Suite 17**  
**Doral, FL 33122**

**SCOPE:**

This NOA is being issued under the applicable rules and regulations governing the use of construction materials. The documentation submitted has been reviewed and accepted by Miami-Dade County RER-Product Control Section to be used in Miami-Dade County and other areas where allowed by the Authority Having Jurisdiction (AHJ).

This NOA shall not be valid after the expiration date stated below. The Miami-Dade County Product Control Section (In Miami-Dade County) and/ or the AHJ (in areas other than Miami-Dade County) reserve the right to have this product or material tested for quality assurance purposes. If this product or material fails to perform in the accepted manner, the manufacturer will incur the expense of such testing and the AHJ may immediately revoke, modify, or suspend the use of such product or material within their jurisdiction. RER reserves the right to revoke this acceptance if it is determined by Miami-Dade County Product Control Section that this product or material fails to meet the requirements of the applicable building code.

This product is approved as described herein and has been designed to comply with the Florida Building Code, including the High Velocity Hurricane Zone.

**DESCRIPTION: Series "AC-0113" Aluminum Window Wall System - S.M.I.**

**APPROVAL DOCUMENT:** Drawing No. **CDM2021-06**, titled "Series 'AC0113' Window Wall System (SMI)", sheets 1 through 7 of 7, dated 07/05/21, prepared by AM American Consulting, Inc., signed and sealed by Daniel Gonzalez, P.E., bearing the Miami-Dade County Product Control Approval stamp with the Notice of Acceptance number and approval date by the Miami-Dade County Product Control Section.

**MISSILE IMPACT RATING: Small Missile Impact Resistant**

**LABELING:** Each unit shall bear a permanent label with the manufacturer's name or logo, city, state, model/series, and following statement: "Miami-Dade County Product Control Approved", unless otherwise noted herein.

**RENEWAL** of this NOA shall be considered after a renewal application has been filed and there has been no change in the applicable building code negatively affecting the performance of this product.

**TERMINATION** of this NOA will occur after the expiration date or if there has been a revision or change in the materials, use, and/ or manufacture of the product or process. Misuse of this NOA as an endorsement of any product, for sales, advertising or any other purposes shall automatically terminate this NOA. Failure to comply with any section of this NOA shall be cause for termination and removal of NOA.

**ADVERTISEMENT:** The NOA number preceded by the words Miami-Dade County, Florida, and followed by the expiration date may be displayed in advertising literature. If any portion of the NOA is displayed, then it shall be done in its entirety.

**INSPECTION:** A copy of this entire NOA shall be provided to the user by the manufacturer or its distributors and shall be available for inspection at the job site at the request of the Building Official.

This NOA consists of this page 1 and evidence pages E-1, E-2, E-3, E-4, E-5 and E-6, as well as approval document mentioned above.

The submitted documentation was reviewed by **Manuel Perez, P.E.**

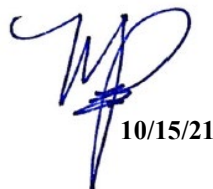

  
10/15/21

NOA No. 21-0823.02  
Expiration Date: February 21, 2024  
Approval Date: October 21, 2021  
Page 1

**NOTICE OF ACCEPTANCE: EVIDENCE SUBMITTED**

**1. EVIDENCE SUBMITTED UNDER PREVIOUS NOA's**

**A. DRAWINGS**

1. Manufacturer's die drawings and sections.  
*(Submitted under NOA No. 18-1031.05)*
2. Drawing No **CDM2017-02**, titled "Series 'AC0113' Window Wall System", sheets 1 through 9 of 9, dated 08/20/18, with revision #1 dated 01/15/21, prepared by AM American Consulting, Inc., signed and sealed by Daniel Gonzalez, P.E.  
*(Submitted under NOA No. 21-0205.10) This is a spinoff from this L.M.I. NOA*

**B. TESTS**

1. Test report on: 1) Uniform Static Air Pressure Test, Loading per PA 202-94 along with marked-up drawings and installation diagram of an aluminum window wall system, prepared by Hurricane Engineering & Testing, Inc., Test Report No. **HETI-17-5098**, dated 08/03/18, signed and sealed by Rafael E. Droz-Seda, P.E.  
*(Submitted under NOA No. 18-1031.05)*
2. Test reports on: 1) Air Infiltration Test, per PA 202-94  
2) Uniform Static Air Pressure Test, Loading per PA 202-94  
3) Water Resistance Test, per PA 202-94  
along with marked-up drawings and installation diagram of an aluminum window wall system, prepared by Hurricane Engineering & Testing, Inc., Test Report No. **HETI-18-6018**, dated 08/03/18, signed and sealed by Rafael E. Droz-Seda, P.E.  
*(Submitted under NOA No. 18-1031.05)*
3. Test reports on: 1) Large Missile Impact Test per PA 201-94  
2) Cyclic Wind Pressure Loading per PA 203-94  
along with marked-up drawings and installation diagram of an aluminum window wall system, prepared by Hurricane Engineering & Testing, Inc., Test Report No. **HETI-18-6019**, dated 08/03/18, signed and sealed by Rafael E. Droz-Seda, P.E.  
*(Submitted under NOA No. 18-1031.05)*
4. Test reports on: 1) Air Infiltration Test, per PA 202-94  
2) Uniform Static Air Pressure Test, Loading per PA 202-94  
3) Water Resistance Test, per PA 202-94  
along with marked-up drawings and installation diagram of an aluminum window wall system, prepared by Hurricane Engineering & Testing, Inc., Test Report No. **HETI-18-6020**, dated 08/03/18, signed and sealed by Rafael E. Droz-Seda, P.E.  
*(Submitted under NOA No. 18-1031.05)*
5. Test report on: 1) Uniform Static Air Pressure Test, Loading per PA 202-94 along with marked-up drawings and installation diagram of an aluminum window wall system, prepared by Hurricane Engineering & Testing, Inc., Test Report No. **HETI-18-6028**, dated 08/03/18, signed and sealed by Rafael E. Droz-Seda, P.E.  
*(Submitted under NOA No. 18-1031.05)*

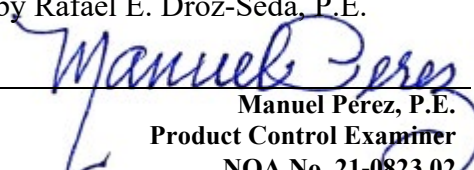
  
\_\_\_\_\_  
Manuel Pérez, P.E.  
Product Control Examiner  
NOA No. 21-0823.02  
Expiration Date: February 21, 2024  
Approval Date: October 21, 2021

**NOTICE OF ACCEPTANCE: EVIDENCE SUBMITTED**

**1. EVIDENCE SUBMITTED UNDER PREVIOUS NOA's (CONTINUED)**  
**B. TESTS (CONTINUED)**

6. Test reports on: 1) Large Missile Impact Test per PA 201-94  
2) Cyclic Wind Pressure Loading per PA 203-94  
along with marked-up drawings and installation diagram of an aluminum window wall system, prepared by Hurricane Engineering & Testing, Inc., Test Report No. **HETI-18-6029**, dated 08/03/18, signed and sealed by Rafael E. Droz-Seda, P.E.  
**(Submitted under NOA No. 18-1031.05)**
7. Test reports on: 1) Large Missile Impact Test per PA 201-94  
2) Cyclic Wind Pressure Loading per PA 203-94  
along with marked-up drawings and installation diagram of an aluminum window wall system, prepared by Hurricane Engineering & Testing, Inc., Test Report No. **HETI-18-6030**, dated 08/03/18, signed and sealed by Rafael E. Droz-Seda, P.E.  
**(Submitted under NOA No. 18-1031.05)**
8. Test report on: 1) Uniform Static Air Pressure Test, Loading per PA 202-94  
along with marked-up drawings and installation diagram of an aluminum window wall system, prepared by Hurricane Engineering & Testing, Inc., Test Report No. **HETI-18-6031**, dated 08/03/18, signed and sealed by Rafael E. Droz-Seda, P.E.  
**(Submitted under NOA No. 18-1031.05)**
9. Test reports on: 1) Large Missile Impact Test per PA 201-94  
2) Cyclic Wind Pressure Loading per PA 203-94  
along with marked-up drawings and installation diagram of an aluminum window wall system, prepared by Hurricane Engineering & Testing, Inc., Test Report No. **HETI-18-6032**, dated 08/03/18, signed and sealed by Rafael E. Droz-Seda, P.E.  
**(Submitted under NOA No. 18-1031.05)**
10. Test report on: 1) Safety Performance Test, (class A) per ANSI Z97.1-84 Sect. 5 and CPSC 16 CFR CH II Part 1201`  
along with marked-up drawings and installation diagram of an aluminum window wall system, prepared by Hurricane Engineering & Testing, Inc., Test Report No. **HETI-18-6039**, dated 08/03/18, signed and sealed by Rafael E. Droz-Seda, P.E.  
**(Submitted under NOA No. 18-1031.05)**
11. Test report on: 1) Uniform Static Air Pressure Test, Loading per PA 202-94  
along with marked-up drawings and installation diagram of an aluminum window wall system, prepared by Hurricane Engineering & Testing, Inc., Test Report No. **HETI-18-6048**, dated 08/03/18, signed and sealed by Rafael E. Droz-Seda, P.E.  
**(Submitted under NOA No. 18-1031.05)**

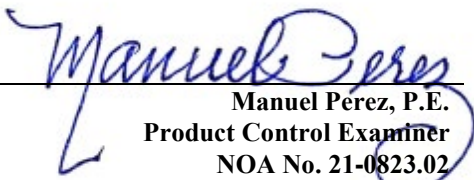
  
Manuel Perez, P.E.  
Product Control Examiner  
NOA No. 21-0823.02  
Expiration Date: February 21, 2024  
Approval Date: October 21, 2021

**NOTICE OF ACCEPTANCE: EVIDENCE SUBMITTED**

**1. EVIDENCE SUBMITTED UNDER PREVIOUS NOA's (CONTINUED)**

**B. TESTS (CONTINUED)**

12. Test reports on: 1) Air Infiltration Test, per PA 202-94  
2) Uniform Static Air Pressure Test, Loading per PA 202-94  
3) Water Resistance Test, per PA 202-94  
along with marked-up drawings and installation diagram of an aluminum window wall system, prepared by Hurricane Engineering & Testing, Inc., Test Report No. **HETI-18-6052**, dated 08/03/18, signed and sealed by Rafael E. Droz-Seda, P.E.  
**(Submitted under NOA No. 18-1031.05)**
13. Test reports on: 1) Large Missile Impact Test per PA 201-94  
2) Cyclic Wind Pressure Loading per PA 203-94  
along with marked-up drawings and installation diagram of an aluminum window wall system, prepared by Hurricane Engineering & Testing, Inc., Test Report No. **HETI-18-6053**, dated 08/03/18, signed and sealed by Rafael E. Droz-Seda, P.E.  
**(Submitted under NOA No. 18-1031.05)**
14. Test report on: 1) Uniform Static Air Pressure Test, Loading per PA 202-94  
along with marked-up drawings and installation diagram of an aluminum window wall system, prepared by Hurricane Engineering & Testing, Inc., Test Report No. **HETI-18-6075**, dated 11/08/18, signed and sealed by Rafael E. Droz-Seda, P.E.  
**(Submitted under NOA No. 18-1031.05)**
15. Test reports on: 1) Large Missile Impact Test per PA 201-94  
2) Cyclic Wind Pressure Loading per PA 203-94  
along with marked-up drawings and installation diagram of an aluminum window wall system, prepared by Hurricane Engineering & Testing, Inc., Test Report No. **HETI-18-6076**, dated 11/08/18, signed and sealed by Rafael E. Droz-Seda, P.E.  
**(Submitted under NOA No. 18-1031.05)**

**C. CALCULATIONS**

1. Anchor verification calculations and structural analysis, complying with **FBC-6<sup>th</sup> Edition (2017)**, dated 10/30/18 and 02/06/19, prepared by AM American Consulting, Inc., signed and sealed by Daniel Gonzalez, P.E.  
**(Submitted under NOA No. 18-1031.05)**
2. Glazing complies with **ASTM E1300-09**

**D. QUALITY ASSURANCE**

1. Miami-Dade Department of Regulatory and Economic Resources (RER)

  
Manuel Perez, P.E.  
Product Control Examiner  
NOA No. 21-0823.02  
Expiration Date: February 21, 2024  
Approval Date: October 21, 2021

**CDM Impact System, Inc.**

**NOTICE OF ACCEPTANCE: EVIDENCE SUBMITTED**

**1. EVIDENCE SUBMITTED UNDER PREVIOUS NOA's (CONTINUED)**

**E. MATERIAL CERTIFICATIONS**

1. Notice of Acceptance No. **18-0725.11** issued to **Kuraray America, Inc.** for their “**Kuraray SentryGlas® Xtra™ (SGX™) Clear Glass Interlayer**” dated 05/23/19, expiring on 05/23/24.
2. Notice of Acceptance No. **19-0305.02** issued to **Kuraray America, Inc.** for their “**Trosifol® Ultraclear, Clear and Color PVB Glass Interlayers**” dated 05/09/19, expiring on 07/08/24.

**F. STATEMENTS**

1. Statement letter of conformance, complying with the **FBC 7<sup>th</sup> Edition (2020)**, dated January 18, 2021, issued by AM American Consulting, Inc., signed and sealed by Daniel Gonzalez, P.E.  
*(Submitted under NOA No. 21-0205.10)*
2. Statement letter of no financial interest with the laboratories, dated October 30, 2018, issued by AM American Consulting, Inc., signed and sealed by Daniel Gonzalez, P.E.  
*(Submitted under NOA No. 18-1031.05)*
3. Proposal No. **17-0374R2** issued by the Product Control Section, dated September 26, 2018, signed by Manuel Perez, P.E.  
*(Submitted under NOA No. 18-1031.05)*

**G. OTHERS**

1. Notice of Acceptance No. **18-1031.05**, issued to CDM Impact System, Inc. for their Series “**AC-0113**” Aluminum Window Wall System – L.M.I., approved on 02/21/19 and expiring on 02/21/24.

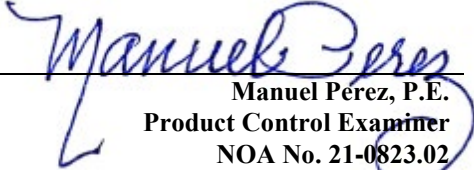
  
Manuel Pérez, P.E.  
Product Control Examiner  
NOA No. 21-0823.02  
Expiration Date: February 21, 2024  
Approval Date: October 21, 2021

**CDM Impact System, Inc.**

**NOTICE OF ACCEPTANCE: EVIDENCE SUBMITTED**

**2. NEW EVIDENCE SUBMITTED**

**A. DRAWINGS**

1. Drawing No **CDM2021-06**, titled “Series ‘AC0113’ Window Wall System (SMI)”, sheets 1 through 7 of 7, dated 07/05/21, prepared by AM American Consulting, Inc., signed and sealed by Daniel Gonzalez, P.E.

**B. TESTS**

1. Test reports on: 1) Small Missile Impact Test per TAS 201-94  
2) Cyclic Wind Pressure Loading per TAS 203-94  
along with marked-up drawings and installation diagram of an aluminum window wall system, prepared by Hurricane Engineering & Testing, Inc., Test Report No. **HETI-21-7028**, dated 05/10/21, signed and sealed by Rafael E. Droz-Seda, P.E.
2. Test reports on: 1) Air Infiltration Test, per PA 202-94  
2) Uniform Static Air Pressure Test, Loading per TAS 202-94  
3) Water Resistance Test, per TAS 202-94  
4) Small Missile Impact Test per TAS 201-94  
5) Cyclic Wind Pressure Loading per TAS 203-94  
along with marked-up drawings and installation diagram of an aluminum window wall system, prepared by Hurricane Engineering & Testing, Inc., Test Report No. **HETI-21-7029**, dated 05/10/21, signed and sealed by Rafael E. Droz-Seda, P.E.
3. Test reports on: 1) Air Infiltration Test, per PA 202-94  
2) Uniform Static Air Pressure Test, Loading per TAS 202-94  
3) Water Resistance Test, per TAS 202-94  
4) Small Missile Impact Test per TAS 201-94  
5) Cyclic Wind Pressure Loading per TAS 203-94  
along with marked-up drawings and installation diagram of an aluminum window wall system, prepared by Hurricane Engineering & Testing, Inc., Test Report No. **HETI-21-7031**, dated 05/10/21, signed and sealed by Rafael E. Droz-Seda, P.E.

**C. CALCULATIONS**

1. Anchor verification calculations and structural analysis, complying with **FBC 7<sup>th</sup> Edition (2020)**, dated 08/16/21, prepared by AM American Consulting, Inc., signed and sealed by Daniel Gonzalez, P.E.
2. Glazing complies with **ASTM E1300-09**.

**D. QUALITY ASSURANCE**

1. Miami-Dade Department of Regulatory and Economic Resources (RER)

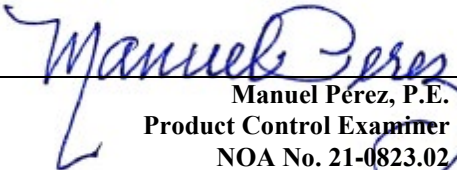
  
Manuel Pérez, P.E.  
Product Control Examiner  
NOA No. 21-0823.02  
Expiration Date: February 21, 2024  
Approval Date: October 21, 2021

**CDM Impact System, Inc.**

**NOTICE OF ACCEPTANCE: EVIDENCE SUBMITTED**

**2. NEW EVIDENCE SUBMITTED (CONTINUED)**

**E. MATERIAL CERTIFICATIONS**

1. Notice of Acceptance No. **20-0915.19** issued to **Kuraray America, Inc.** for their “**SentryGlas® (Clear and White) Glass Interlayers**” dated 11/19/20, expiring on 07/04/23.
2. Notice of Acceptance No. **20-0915.22** issued to **Kuraray America, Inc.** for their “**Trosifol® Ultraclear, Clear and Color PVB Glass Interlayers**” dated 11/19/20, expiring on 07/08/24.

**F. STATEMENTS**

1. Statement letter of conformance, complying with **FBC 7<sup>th</sup> Edition (2020)**, dated August 10, 2021, issued by AM American Consulting, Inc., signed and sealed by Daniel Gonzalez, P.E.
2. Statement letter of no financial interest, dated August 10, 2021, issued by AM American Consulting, Inc., signed and sealed by Daniel Gonzalez, P.E.
3. Proposal No. **19-1285** issued by the Product Control Section, dated December 6, 2019, signed by Manuel Perez, P.E.

**G. OTHERS**

1. Notice of Acceptance No. **21-0205.10**, issued to CDM Impact System, Inc. for their Series “**AC-0113**” Aluminum Window Wall System – L.M.I., approved on 05/06/21 and expiring on 02/21/24.  
*(For reference only – Used as original NOA base of this spin-off)*

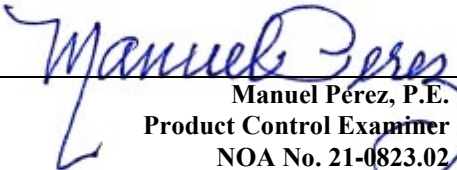
  
Manuel Pérez, P.E.  
Product Control Examiner  
NOA No. 21-0823.02  
Expiration Date: February 21, 2024  
Approval Date: October 21, 2021

# SERIES "AC-0113" WINDOW WALL SYSTEM

LAMINATED GLASS / INSULATED LAMINATED GLASS  
SMALL MISSILE IMPACT.

THIS PRODUCT HAS BEEN DESIGNED AND TESTED TO COMPLY WITH THE REQUIREMENTS OF THE 2020 (7TH EDITION) FLORIDA BUILDING CODE INCLUDING HIGH VELOCITY HURRICANE ZONE (HVHZ).

THIS SYSTEM IS RATED FOR SMALL MISSILE IMPACT  
SHUTTERS NOT REQUIRED FOR INSTALLATIONS ABOVE 30 FT OF GRADE.  
MIAMI DADE COUNTY APPROVED IMPACT RESISTANT SHUTTERS REQUIRED FOR INSTALLATIONS UP TO 30 FT OF GRADE.

ANCHORS SHALL BE CORROSION RESISTANT, SPACED AS SHOWN ON DETAILS AND INSTALLED PER MANUFACTURER'S INSTRUCTIONS. SPECIFIED EMBEDMENT TO BASE MATERIAL SHALL BE BEYOND WALL DRESSING OR STUCCO.

ALL SHIMS TO BE HIGH IMPACT, NON-METALLIC AND NON-COMPRESSIBLE.

MATERIALS INCLUDING BUT NOT LIMITED TO STEEL/METAL SCREWS, THAT COME INTO CONTACT WITH OTHER DISSIMILAR MATERIALS SHALL MEET THE REQUIREMENTS OF THE 2020 FLORIDA BLDG. CODE & ADOPTED STANDARDS.

THIS PRODUCT APPROVAL IS GENERIC AND DOES NOT PROVIDE INFORMATION FOR A SITE SPECIFIC PROJECT, i.e. LIFE SAFETY OF THIS PRODUCT, ADEQUACY OF STRUCTURE RECEIVING THIS PRODUCT AND SEALING AROUND OPENING FOR WATER INFILTRATION ETC. CONDITIONS NOT SHOWN IN THIS DRAWING ARE TO BE ANALYZED SEPARATELY AND TO BE REVIEWED BY BUILDING OFFICIAL.

PRODUCT COMPLIES WITH  
REQUIREMENTS OF ANSI Z97.1

## DESIGN INSTRUCTIONS:

**STEP 1:** DETERMINE DESIGN WIND LOAD REQUIREMENT BASED ON WIND VELOCITY, BLDG. HEIGHT, WIND ZONE USING APPLICABLE ASCE-07 STANDARD.

**STEP 2:** SEE CHARTS ON SHEET 2 FOR DESIGN LOAD CAPACITY OF DESIRED GLASS.

**STEP 3:** CHECK JAMB & MULLION CAPACITY FOR A GIVEN SPACING AND HEIGHT USING CHARTS ON SHEET 2.

**STEP 4:** CHECK ANCHORS QUANTITIES FOR WINDOW WALL SYSTEM USING CHARTS ON SHEET 3.

**STEP 5:** THE LOWEST VALUE RESULTING FROM STEPS 2, 3 & 4 SHALL APPLY TO THE ENTIRE SYSTEM.

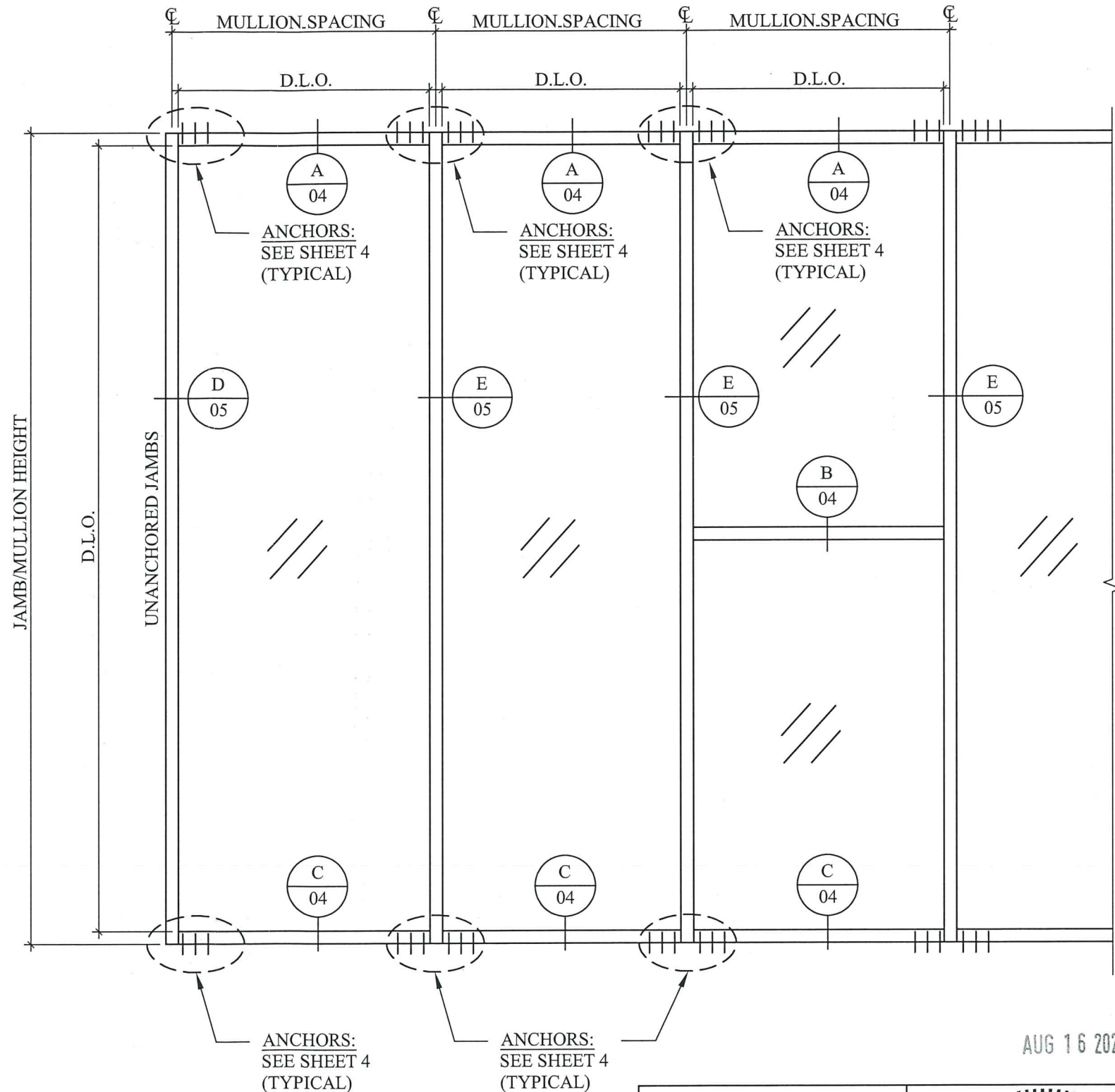

AUG 16 2021

**PRODUCT REVISED**  
as complying with the Florida  
Building Code  
NOA-No. **21-0823.02**  
Expiration Date: **02/21/2024**  
By: *Manuel Perez*  
Miami-Dade Product Control

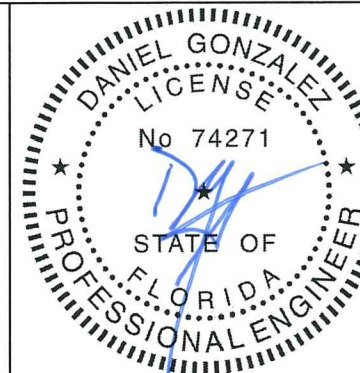

AM American Consulting, Inc.  
10300 SW 72nd Street, Suite 455, Miami, FL 33173  
Ph (786) 219 9490 / www.americanconsulting.com  
Cert. Authorization No. 31388



8303 NW 27th Street, Suite 17, Doral, FL 33122 / Ph: 305-267-1011

NO.	DATE	BY	REVISION

SERIES "AC0113" WINDOW WALL SYSTEM (SMI)	
Drawings No:	CDM 2021-06
Drawn by:	AP
Checked by:	DG
Date:	07/5/21
Scale:	
SHEET No: 1 of 7	

GLASS LOAD CAPACITY - PSF		
NOMINAL DIMS. (INCH)		G2 & G2A
D.L.O. WIDTH (in)	D.L.O. HEIGHT (in)	EXT. (+) INT. (-)
up to:	up to:	
76	84	150.0
86		130.0
71	90	150.0
80		130.0
66	96	150.0
75		130.0
62	102	150.0
71		130.0
59	108	150.0
67		130.0
56	114	150.0
63 1/2		130.0
53	120	150.0
60		150.0
50	126	150.0
57		130.0
48	132	150.0
54 1/2		130.0
46	138	150.0
52 1/2		130.0
45	142	150.0
51		130.0

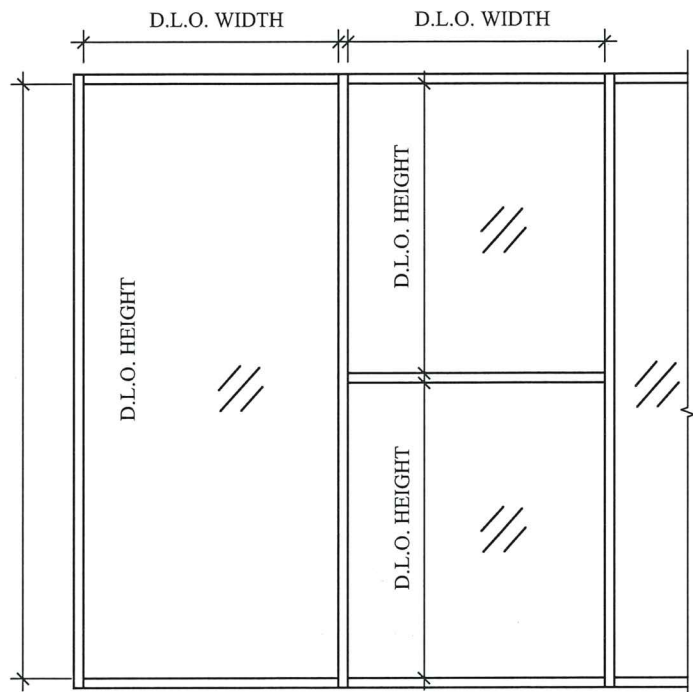

D.L.O. WIDTH = MULLIONS SPACING - 3"  
D.L.O. HEIGHT = FRAME HEIGHT - 6"

MULLION/JAMB LOAD CAPACITY - PSF		
NOMINAL DIMS.		JAMB "HV" MULL "HV"
MULLION SPACING	JAMB/MULLION HEIGHT	EXT. (+) INT. (-)
up to:	up to:	
89	90	130.0
83.5	96	130.0
78.5	102	130.0
74	108	130.0
70	114	130.0
66	120	130.0
63.5	126	130.0
60	132	130.0
58	138	130.0
55	144	130.0
54	148	130.0

MULLION/JAMB LOAD CAPACITY - PSF		
NOMINAL DIMS.		JAMB "HV" MULL "HVR"
MULLION SPACING	JAMB/MULLION HEIGHT	EXT. (+) INT. (-)
up to:	up to:	
79	90	150.0
74	96	150.0
69.5	102	150.0
66	108	150.0
62.5	114	150.0
59	120	150.0
56.5	126	150.0
54	132	150.0
51.5	138	150.0
49.5	144	150.0
48	148	150.0

NOTES:  
1. INTERPOLATION ALLOWED.  
2. BOXES WITH "-" MEANS THIS COMBINATION IS NOT QUALIFIED

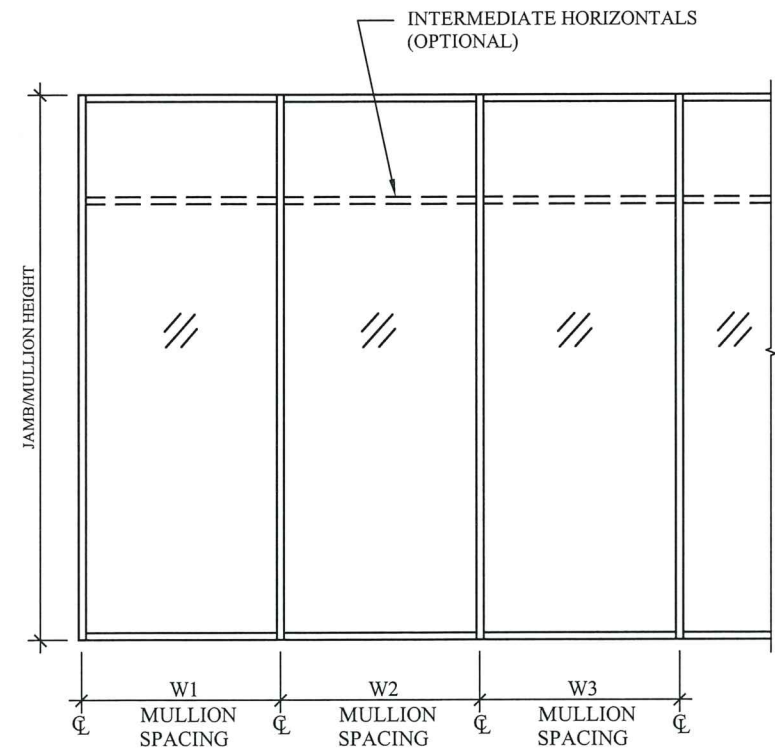

WIDTH (W) AT JAMB = W1  
WIDTH (W) AT INT. MULLION =  $\frac{W2+W3}{2}$

NOTES:  
1. INTERPOLATION ALLOWED  
2. GLASS CAPACITIES ARE BASED ASTM E1300-09 (3 SEC. GUSTS)

GLAZING OPTIONS:

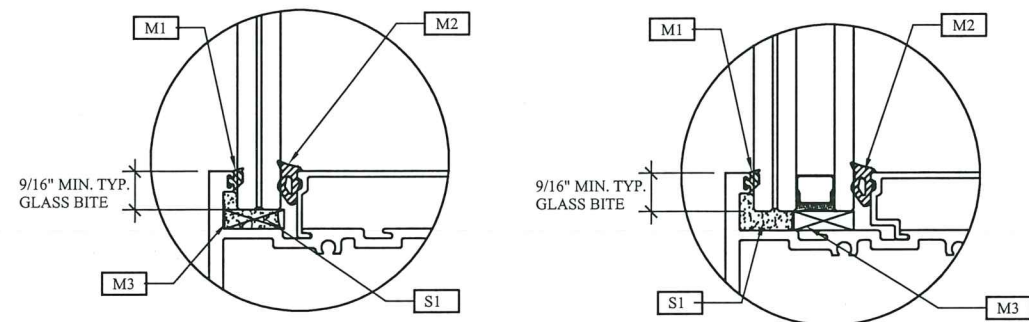

**GLASS TYPE "G-2"**  
9/16" LAMINATED GLASS  
1/4" HEAT STRENGTH GLASS  
0.090" SENTRYGLAS INTERLAYER BY KURARAY AMERICA, INC.  
1/4" HEAT STRENGTH GLASS

**GLASS TYPE "G-2A"**  
1 5/16" INSULATED -LAMINATED GLASS  
1/4" HEAT STRENGTH GLASS  
0.090" SENTRYGLAS INTERLAYER BY KURARAY AMERICA, INC.  
1/4" HEAT STRENGTH GLASS  
0.50" AIR SPACE  
1/4" TEMPERED GLASS

JAMB/MULLIONS OPTIONS:

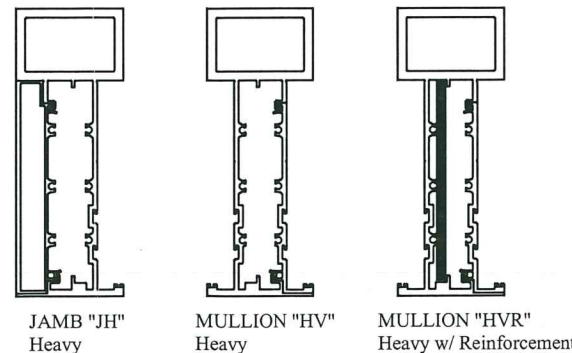

	Ix (in4)	Sx (in3)
JAMB "JH" Heavy	42.1485	9.8473
MULLION "HV" Heavy		
MULLION "HVR" Heavy w/ Reinforcement		
ALUMINUM	42.1485	9.8473
STEEL	3.4661	1.2604
TOTAL	52.2001	
Ix ALUM. + (2.9) Ix STEEL		

AUG 16 2021

**PRODUCT REVISED**  
as complying with the Florida Building Code  
NOA-No. **21-0823.02**  
Expiration Date: **02/21/2024**  
By: *Manuel Perez*  
Miami-Dade Product Control

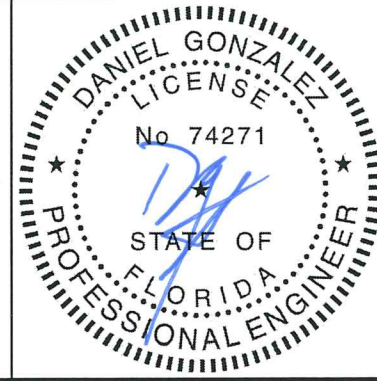

SERIES "AC0113"  
WINDOW WALL SYSTEM (SMI)  
Drawings No: CDM 2021-06  
Drawn by: AP  
Checked by: DG  
Date: 07/5/21  
Scale:  
SHEET No: 2 of 7

**AM**  
AM American Consulting, Inc.  
10300 SW 72nd Street, Suite 455, Miami, FL 33173  
Ph (786) 219 9490 / www.americanconsulting.com  
Cert. Authorization No. 31388

**IMPACT SYSTEM**  
8303 NW 27th Street, Suite 17, Doral, FL 33122 / Ph: 305-267-1011

NOMINAL DIMS. (in)		ANCHOR LOAD CAPACITY - PSF (HEAD & SILL) EXT. (+) & INT. (-) (PSF)												
FRAME WIDTH	FRAME HEIGHT	1/4" MAX. SHIM												
		ANCHORS TYPE "A"			ANCHORS TYPE "B"			ANCHORS TYPE "C"			ANCHORS TYPE "D"			
		A4	A5	A6	B4	B5	B6	C4	C5	D6	D7	D8	D9	D10
48	90	116.0	145.0	150.0	150.0	150.0	150.0	150.0	150.0	108.8	126.9	145.1	150.0	150.0
54	90	103.1	128.9	150.0	150.0	150.0	150.0	150.0	150.0	96.7	112.8	128.9	145.1	150.0
60	90	92.8	116.0	139.2	150.0	150.0	150.0	150.0	150.0	87.0	101.5	116.1	130.6	145.1
66	90	84.4	105.5	126.5	139.6	150.0	150.0	145.5	150.0	79.1	92.3	105.5	118.7	131.9
72	90	77.3	96.7	116.0	128.0	150.0	150.0	133.3	150.0	72.5	84.6	96.7	108.8	120.9
78	90	71.4	89.2	107.1	118.2	147.7	150.0	123.1	150.0	67.0	78.1	89.3	100.4	111.6
84	90	66.3	82.9	99.4	109.7	137.1	150.0	114.3	142.9	62.2	72.5	82.9	93.3	103.6
90	90	61.9	77.3	92.8	102.4	128.0	150.0	106.7	133.3	58.0	67.7	77.4	87.0	96.7
48	96	108.8	135.9	150.0	150.0	150.0	150.0	150.0	150.0	102.0	119.0	136.0	150.0	150.0
54	96	96.7	120.8	145.0	150.0	150.0	150.0	150.0	150.0	90.7	105.8	120.9	136.0	150.0
60	96	87.0	108.8	130.5	144.0	150.0	150.0	150.0	150.0	81.6	95.2	108.8	122.4	136.0
66	96	79.1	98.9	118.6	130.9	150.0	150.0	136.4	150.0	74.2	86.5	98.9	111.3	123.6
72	96	72.5	90.6	108.8	120.0	150.0	150.0	125.0	150.0	68.0	79.3	90.7	102.0	113.3
78	96	66.9	83.7	100.4	110.8	138.5	150.0	115.4	144.2	62.8	73.2	83.7	94.2	104.6
84	96	62.1	77.7	93.2	102.9	128.6	150.0	107.1	133.9	58.3	68.0	77.7	87.4	97.1
48	102	102.4	127.9	150.0	150.0	150.0	150.0	150.0	150.0	96.0	112.0	128.0	144.0	150.0
54	102	91.0	113.7	136.5	150.0	150.0	150.0	150.0	150.0	85.3	99.6	113.8	128.0	142.2
60	102	81.9	102.4	122.8	135.5	150.0	150.0	141.2	150.0	76.8	89.6	102.4	115.2	128.0
66	102	74.4	93.0	111.7	123.2	150.0	150.0	128.3	150.0	69.8	81.5	93.1	104.7	116.4
72	102	68.2	85.3	102.4	112.9	141.2	150.0	117.6	147.1	64.0	74.7	85.3	96.0	106.7
78	102	63.0	78.7	94.5	104.3	130.3	150.0	108.6	135.7	59.1	68.9	78.8	88.6	98.5
48	108	96.7	120.8	145.0	150.0	150.0	150.0	150.0	150.0	90.7	105.8	120.9	136.0	150.0
54	108	85.9	107.4	128.9	142.2	150.0	150.0	148.1	150.0	80.6	94.0	107.5	120.9	134.3
60	108	77.3	96.7	116.0	128.0	150.0	150.0	133.3	150.0	72.5	84.6	96.7	108.8	120.9
66	108	70.3	87.9	105.5	116.4	145.5	150.0	121.2	150.0	65.9	76.9	87.9	98.9	109.9
72	108	64.4	80.6	96.7	106.7	133.3	150.0	111.1	138.9	60.4	70.5	80.6	90.7	100.7
74	108	62.7	78.4	94.1	103.8	129.7	150.0	108.1	135.1	58.8	68.6	78.4	88.2	98.0
48	114	91.6	114.5	137.4	150.0	150.0	150.0	150.0	150.0	85.9	100.2	114.5	128.8	143.2
54	114	81.4	101.8	122.1	134.7	150.0	150.0	140.4	150.0	76.4	89.1	101.8	114.5	127.3
60	114	73.3	91.6	109.9	121.3	150.0	150.0	126.3	150.0	68.7	80.2	91.6	103.1	114.5
66	114	66.6	83.3	99.9	110.2	137.8	150.0	114.8	143.5	62.5	72.9	83.3	93.7	104.1
70	114	62.8	78.5	94.2	103.9	129.9	150.0	108.3	135.3	58.9	68.7	78.5	88.3	98.2
48	120	87.0	108.8	130.5	144.0	150.0	150.0	150.0	150.0	81.6	95.2	108.8	122.4	136.0
54	120	77.3	96.7	116.0	128.0	150.0	150.0	133.3	150.0	72.5	84.6	96.7	108.8	120.9
60	120	69.6	87.0	104.4	115.2	144.0	150.0	120.0	150.0	65.3	76.2	87.0	97.9	108.8
66	120	63.3	79.1	94.9	104.7	130.9	150.0	109.1	136.4	59.3	69.2	79.1	89.0	98.9
48	126	82.9	103.6	124.3	137.1	150.0	150.0	142.9	150.0	77.7	90.7	103.6	116.6	129.5
54	126	73.7	92.1	110.5	121.9	150.0	150.0	127.0	150.0	69.1	80.6	92.1	103.6	115.1
60	126	66.3	82.9	99.4	109.7	137.1	150.0	114.3	142.9	62.2	72.5	82.9	93.3	103.6
63	126	63.1	78.9	94.7	104.5	130.6	150.0	108.8	136.1	59.2	69.1	78.9	88.8	98.7
48	132	79.1	98.9	118.6	130.9	150.0	150.0	136.4	150.0	74.2	86.5	98.9	111.3	123.6
54	132	70.3	87.9	105.5	116.4	145.5	150.0	121.2	150.0	65.9	76.9	87.9	98.9	109.9
60	132	63.3	79.1	94.9	104.7	130.9	150.0	109.1	136.4	59.3	69.2	79.1	89.0	98.9
48	138	75.7	94.6	113.5	125.2	150.0	150.0	130.4	150.0	71.0	82.8	94.6	106.4	118.3
54	138	67.2	84.1	100.9	111.3	139.1	150.0	115.9	144.9	63.1	73.6	84.1	94.6	105.1
58	138	62.6	78.3	93.9	103.6	129.5	150.0	107.9	134.9	58.7	68.5	78.3	88.1	97.9
48	144	72.5	90.6	108.8	120.0	150.0	150.0	125.0	150.0	68.0	79.3	90.7	102.0	113.3
55	144	63.3	79.1	94.9	104.7	130.9	150.0	109.1	136.4	59.3	69.2	79.1	89.0	98.9
48	148	70.5	88.2	105.8	116.8	145.9	150.0	121.6	150.0	66.2	77.2	88.2	99.2	110.3
54	148	62.7	78.4	94.1	103.8	129.7	150.0	108.1	135.1	58.8	68.6	78.4	88.2	98.0

**TYPICAL ANCHORS:**

**TYPE "A"**

1/4" ULTRACON BY "DEWALT"  
(Fu=177 KSI, Fy=155 KSI)

DIRECTLY INTO CONCRETE  
WITH 1-3/4" MIN. EMBED INTO CONCRETE

ANCHOR EDGE DISTANCES  
INTO CONCRETE AND MASONRY = 2-1/2" MIN.

**TYPE "B"**

5/16" DIA ULTRACON BY "DEWALT"  
(Fu=177 KSI, Fy=155 KSI)

DIRECTLY INTO CONCRETE  
WITH 2" MIN. EMBED INTO CONCRETE

ANCHOR EDGE DISTANCES  
INTO CONCRETE AND MASONRY = 3-1/8" MIN.

**TYPE "C"**

1/4" DIA TEKS OR SELF DRILLING SCREWS  
(Fu=120 KSI, Fy=92 KSI) (SAE GRADE 5)

INTO METAL STRUCTURES  
(3) THREADS MIN. PENETRATION BEYOND SUBSTRATE  
ALUMINUM: 1/8" THK. MIN (6063-T6 MIN.)  
STEEL: 1/8" THK. MIN (Fy = 36 KSI MIN.)  
(STEEL IN CONTACT WITH ALUMINUM TO BE PLATED  
OR PAINTED)

ANCHOR EDGE DISTANCES  
INTO METAL STRUCTURE = 1/2" MIN.

**TYPE "D"**

1/4" ULTRACON BY "DEWALT"  
(Fu=177 KSI, Fy=155 KSI)

INTO 2BY WOOD BUCKS OR WOOD STRUCTURES  
WITH 1-1/2" MIN. PENETRATION INTO WOOD

THRU 1BY WOOD BUCKS INTO CONCRETE  
WITH 1-3/4" MIN. EMBED INTO CONCRETE

ANCHOR EDGE DISTANCES  
INTO CONCRETE AND MASONRY = 2-1/2" MIN.  
INTO WOOD STRUCTURE = 1" MIN.

WOOD AT HEAD, SILL SG = 0.55 MIN.  
CONCRETE AT HEAD, SILL Fc = 3000 PSI MIN.

**SEALANTS:**

ALL FRAME CORNERS, JOINTS, MULLION SEAMS,  
AND PERIMETER OF GLAZING BEAD TO FRAME  
SEALED WITH SILICONE SEALANT.

HEX AND/OR FLAT HEAD ARE ALLOWED.

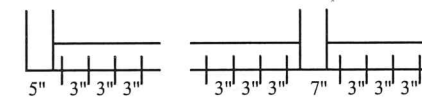

A4, B4, C4, D4 (4) ANCHORS AT EACH SIDE OF  
JAMB AND MULLION

FOR ANCHORS TYPE B  
USE 3 3/4" SPACING INSTEAD 3"

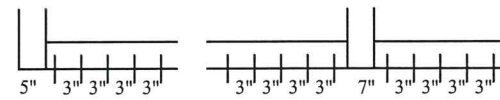

A5, B5, C5, D5 (5) ANCHORS AT EACH SIDE OF  
JAMB AND MULLION

FOR ANCHORS TYPE B  
USE 3 3/4" SPACING INSTEAD 3"

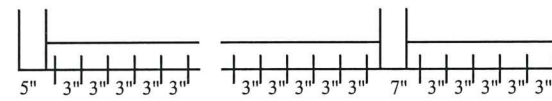

A6, B6, C6, D6 (6) ANCHORS AT EACH SIDE OF  
JAMB AND MULLION

FOR ANCHORS TYPE B  
USE 3 3/4" SPACING INSTEAD 3"

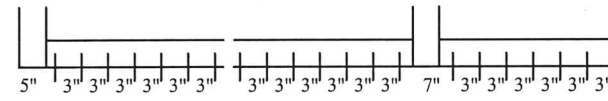

D7 (7) ANCHORS AT EACH SIDE OF JAMB AND MULLION

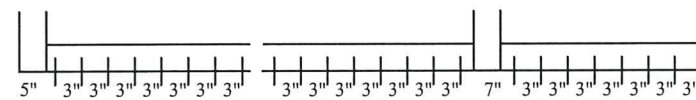

D8 (8) ANCHORS AT EACH SIDE OF JAMB AND MULLION

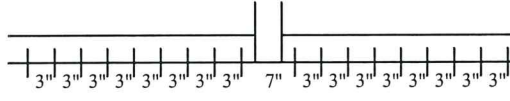
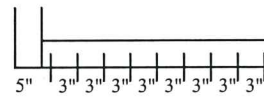

D9 (9) ANCHORS AT EACH SIDE OF JAMB AND MULLION

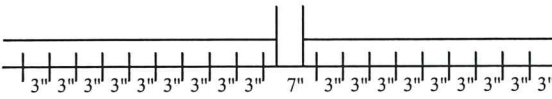
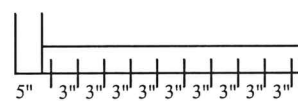

D10 (10) ANCHORS AT EACH SIDE OF JAMB AND MULLION

**PRODUCT REVISED**  
as complying with the Florida  
Building Code  
NOA-No. **21-0823.02**  
Expiration Date: **02/21/2024**  
By: *Manuel Perez*  
Miami-Dade Product Control

**DANIEL GONZALEZ**  
LICENSE  
No 74271  
STATE OF  
FLORIDA  
PROFESSIONAL ENGINEER

SERIES "AC0113"  
WINDOW WALL  
SYSTEM  
(SMI)  
Drawings No:  
CDM 2021-06  
Drawn by: AP  
Checked by: DG  
Date: 07/5/21  
Scale:  
SHEET No:  
3 of 7

**ACM**  
AM American Consulting, Inc.  
10300 SW 72nd Street, Suite 455, Miami, FL 33173  
Ph (786) 219 9490 / www.americanconsulting.com  
Cert. Authorization No. 31388

**IMPACT SYSTEM**  
8303 NW 27th Street, Suite 17, Doral, FL 33122 / Ph: 305-267-1011

NO.	
DATE	
BY	
REVISION	

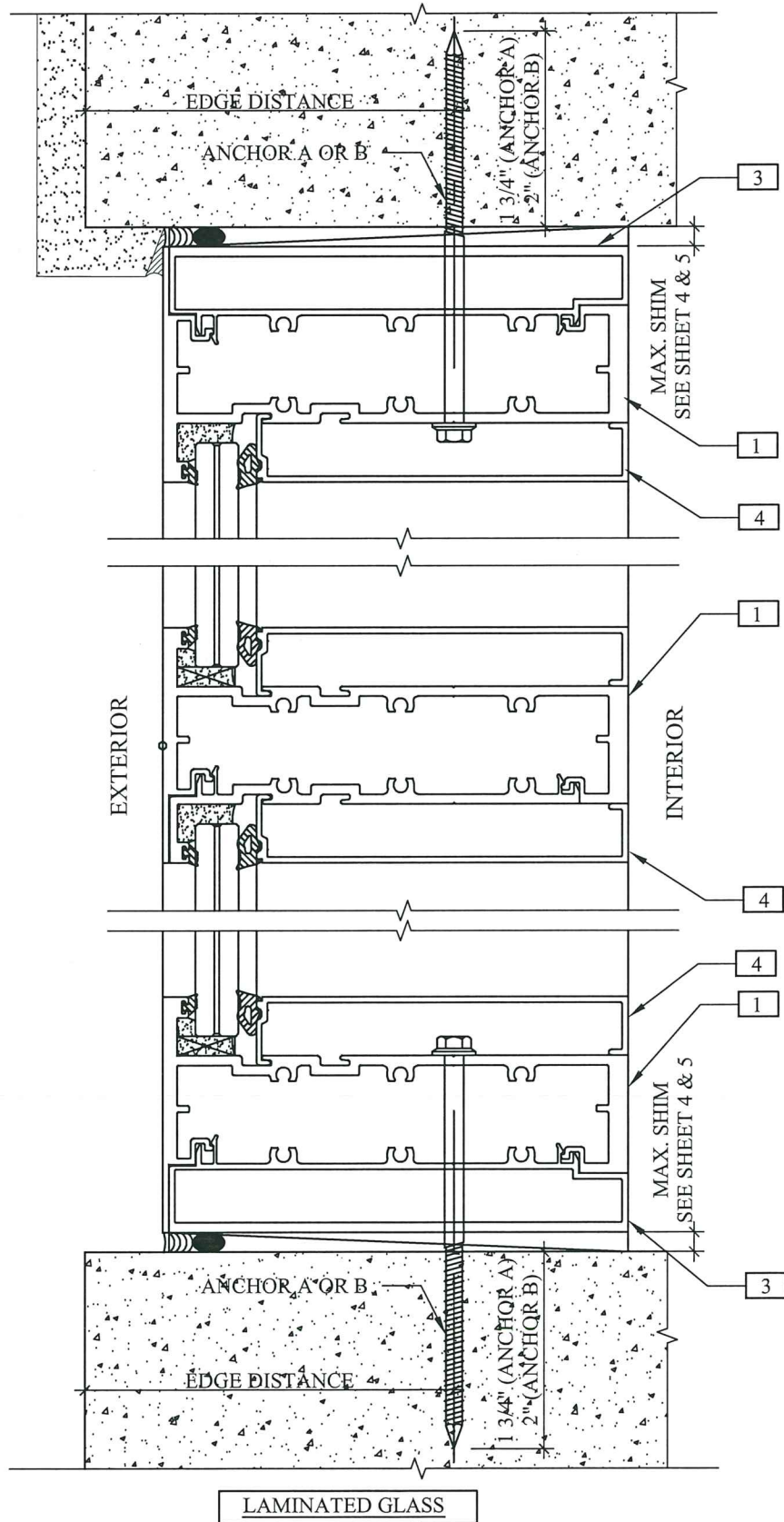

DETAIL A

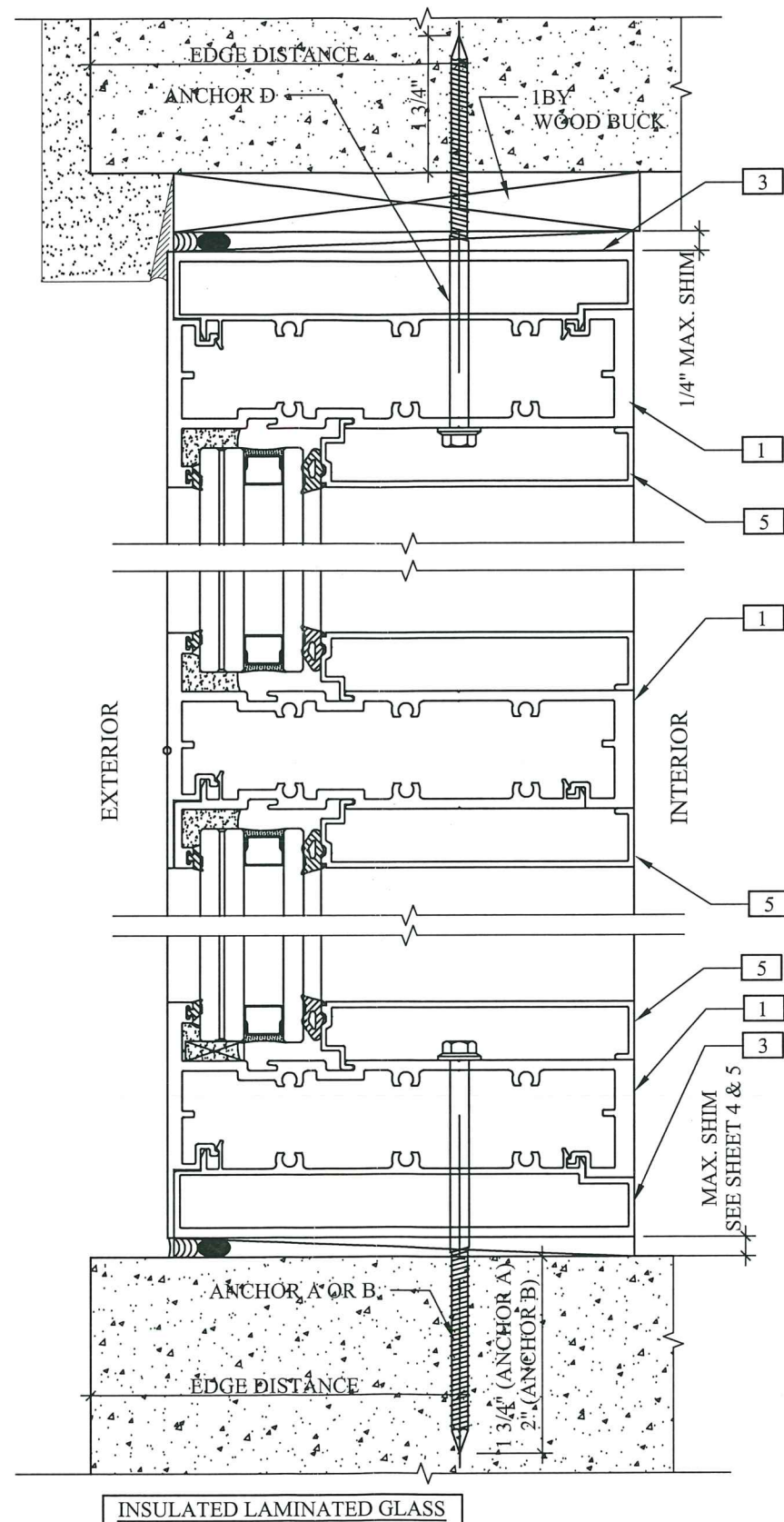

DETAIL B

LAMINATED GLASS

INSULATED LAMINATED GLASS

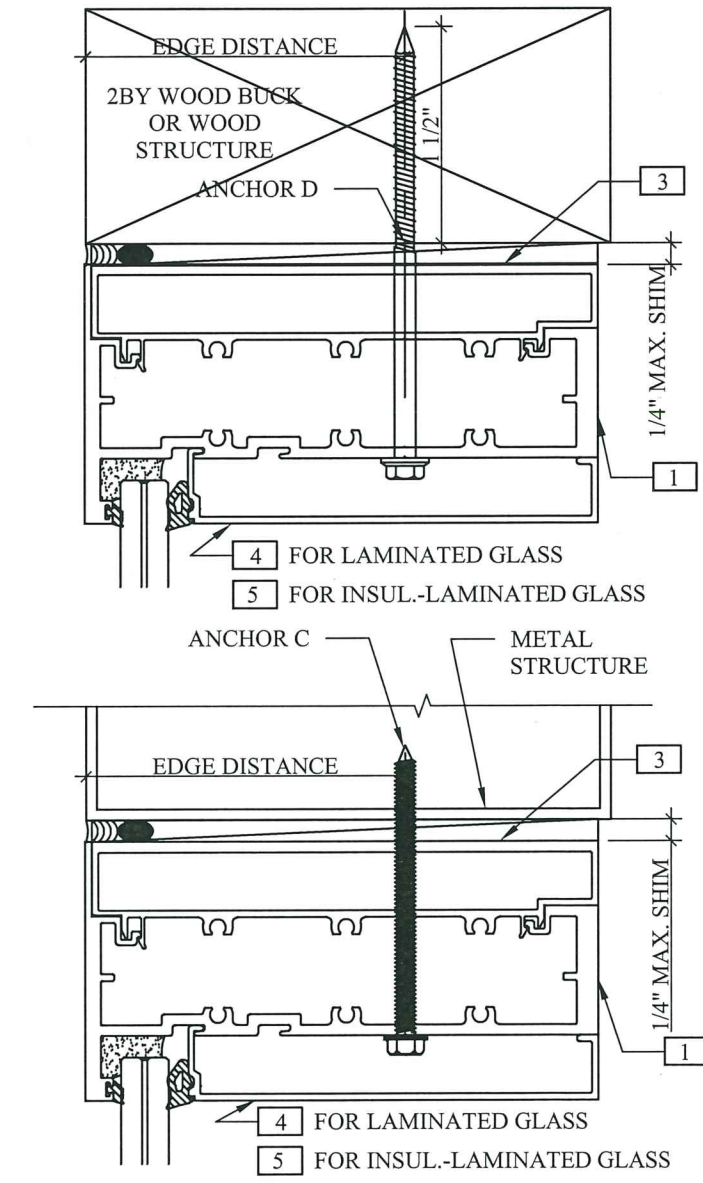

WOOD BUCKS AND METAL STRUCTURES NOT BY CDM MUST SUPPORT LOADS IMPOSED BY GLAZING SYSTEM AND TRANSFER THEM TO THE BUILDING STRUCTURE.

SEE SHEET 3 FOR ANCHOR DESCRIPTION.

**PRODUCT REVISED**  
 as complying with the Florida Building Code  
 NOA-No. **21-0823.02**  
 Expiration Date: **02/21/2024**  
 By: *Manuel Torres*  
 Miami-Dade Product Control

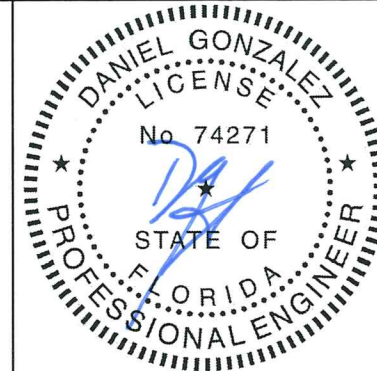

**AM**  
 AM American Consulting, Inc.  
 10300 SW 72nd Street, Suite 455, Miami, FL 33173  
 Ph: (786) 219 9490 / www.americanconsulting.com  
 Cert. Authorization No. 31388

**CDM**  
 IMPACT SYSTEM  
 8303 NW 27th Street, Suite 17, Doral, FL 33122 / Ph: 305-267-1011

NO.	DATE	BY	REVISION

SERIES "AC0113"  
 WINDOW WALL SYSTEM (SMI)  
 Drawings No: CDM 2021-06  
 Drawn by: AP  
 Checked by: DG  
 Date: 07/5/21  
 Scale:  
 SHEET No: 4 of 7

AUG 16 2021

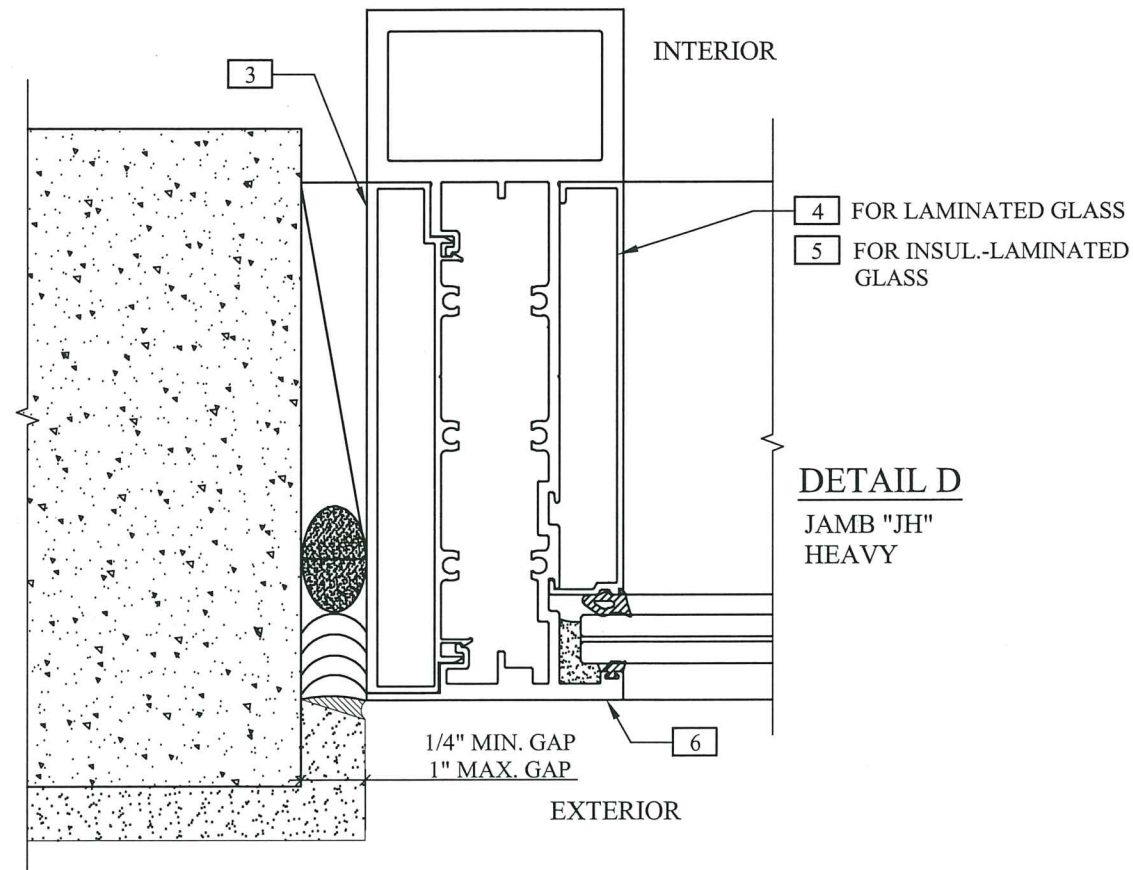

**DETAIL D**  
JAMB "JH"  
HEAVY

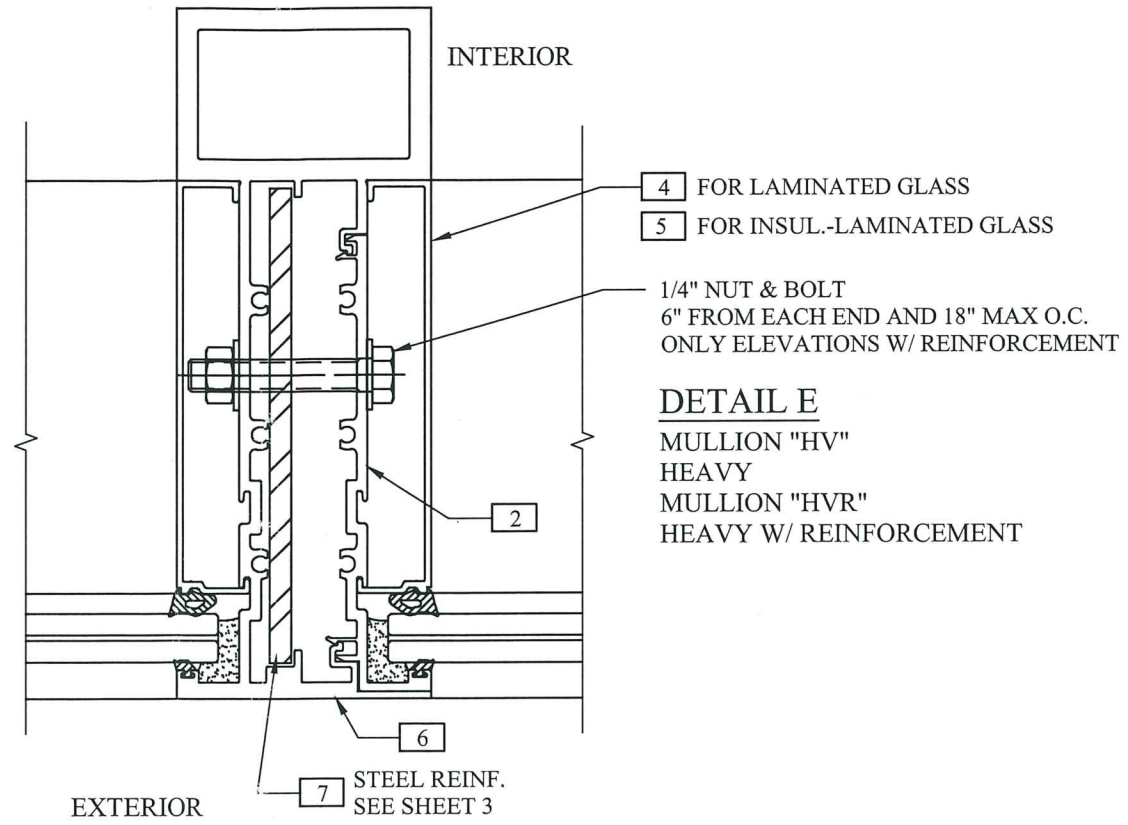

**DETAIL E**  
MULLION "HV"  
HEAVY  
MULLION "HVR"  
HEAVY W/ REINFORCEMENT



AM American Consulting, Inc.  
10300 SW 72nd Street, Suite 455, Miami, FL 33173  
Ph: (786) 219 9490 / www.americanconsulting.com  
Cert. Authorization No. 31388



8303 NW 27th Street, Suite 17, Doral, FL 33122 / Ph: 305-267-1011

NO.	DATE	BY	REVISION

AUG 16 2021

**PRODUCT REVISED**  
as complying with the Florida  
Building Code  
NOA-No. **21-0823.02**  
Expiration Date: **02/21/2024**  
By: *Manuel Perez*  
Miami-Dade Product Control

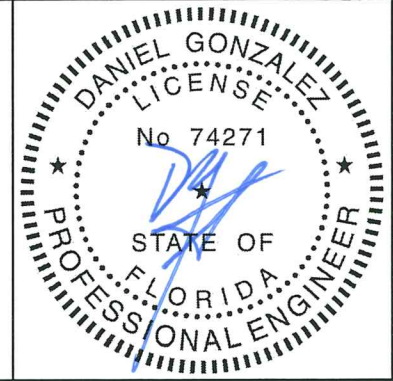

SERIES "AC0113"  
WINDOW WALL  
SYSTEM  
(SMI)  
Drawings No:  
CDM 2021-06  
Drawn by: AP  
Checked by: DG  
Date: 07/5/21  
Scale:  
SHEET No:  
5 of 7

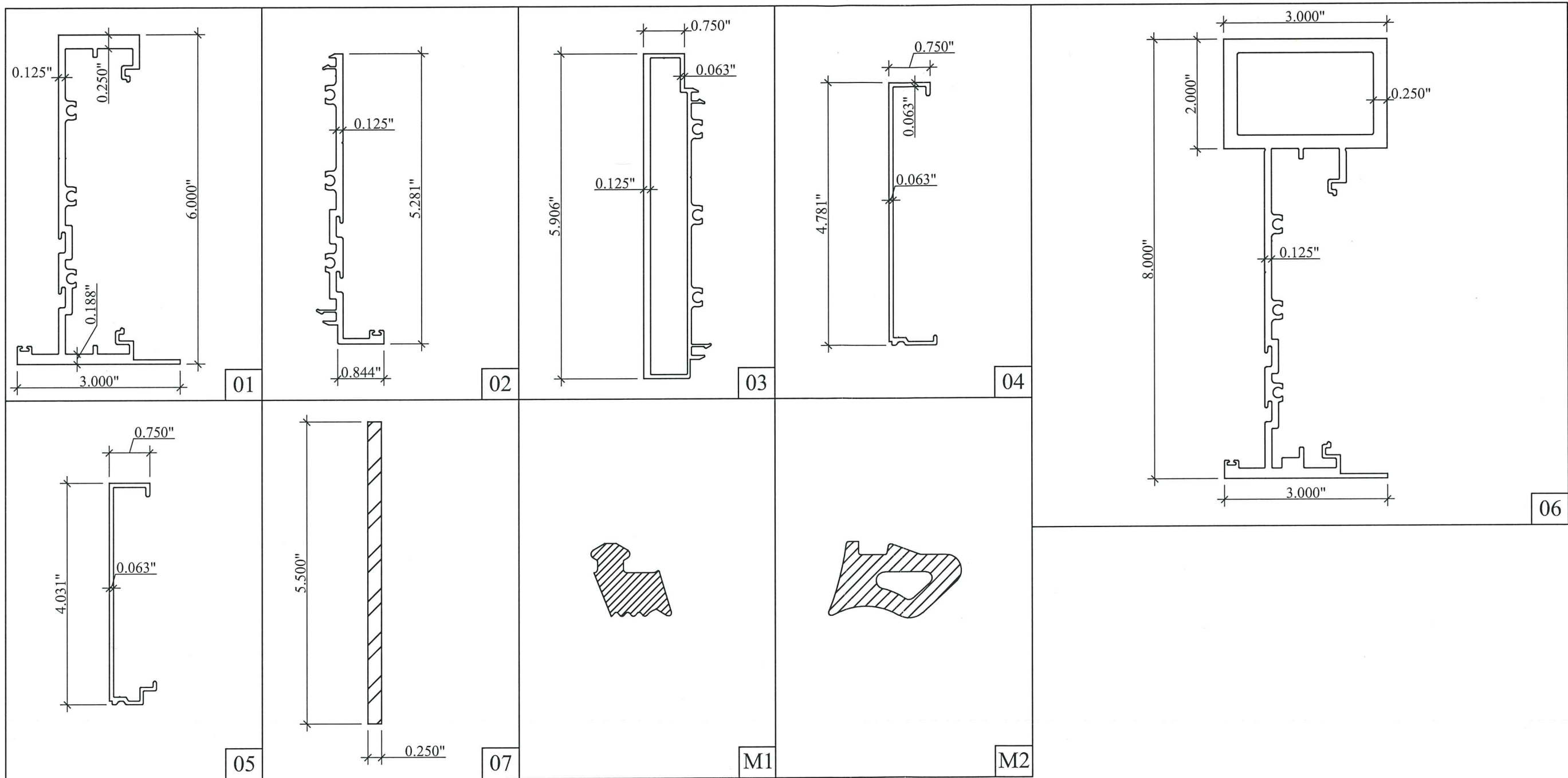

ITEM NO.	PART NUMBER	QUANTITY	DESCRIPTION	MATERIAL	OBSERVATIONS
1	AC-001	AS REQD.	STANDARD FEMALE MULLION	ALUMINUM	ALLOY 6063-T6
2	AC-002	AS REQD.	MALE MULLION	ALUMINUM	ALLOY 6063-T6
3	AC-003	AS REQD.	SNAP COVER	ALUMINUM	ALLOY 6063-T6
4	AC-004	AS REQD.	GLASS STOP FOR LAMINATED GLASS	ALUMINUM	ALLOY 6063-T6
5	AC-005	AS REQD.	GLASS STOP FOR INSULATED LAMINATED GLASS	ALUMINUM	ALLOY 6063-T6
6	AC-006	AS REQD.	HEAVY FEMALE MULLION	ALUMINUM	ALLOY 6063-T6
7	AC-007	AS REQD.	1/4" STEEL REINFORCEMENT	STEEL	A36
M1	G-01	AS REQD.	SPACER GASKET	SILICONE	70 +/- 5 DUROMETER
M2	G-02	AS REQD.	WEDGE GASKET	SILICONE	80 +/- 5 DUROMETER
M3	-	2/ LITE	3/16" X 1/2" X 2" LONG SETTING BLOCK, AT 1/4" POINTS	EPDM OR SILICONE	-
S1	-	AS REQD.	SILICONE DC983 OR DC995	SILICONE	DOW CORNING
F1	-	AS REQD.	#12 X 1-1/2" FH SMS	S.S.	ASSEMBLY SCREW
F2	-	AS REQD.	#12 X 1-1/2" HWH SMS	S.S.	ASSEMBLY SCREW

**PRODUCT REVISED**  
 as complying with the Florida  
 Building Code  
 NOA-No. **21-0823.02**  
 Expiration Date: **02/21/2024**  
 By: *Manuel Perez*  
 Miami-Dade Product Control

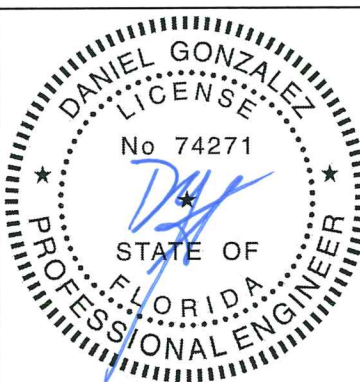

SERIES "AC0113"  
 WINDOW WALL  
 SYSTEM  
 (SMI)  
 Drawings No:  
 CDM 2021-06  
 Drawn by: AP  
 Checked by: DG  
 Date: 07/5/21  
 Scale:  
 SHEET No:  
 6 of 7



8303 NW 27th Street, Suite 17, Doral, FL 33122 / Ph: 305-267-1011

**AM**  
 AM American Consulting, Inc.  
 10300 SW 72nd Street, Suite 455, Miami, FL 33173  
 Ph (786) 219-9490 / www.amamericanc consulting.com  
 Cert. Authorization No. 31388

AUG 16 2021

NO.	DATE	BY	REVISION

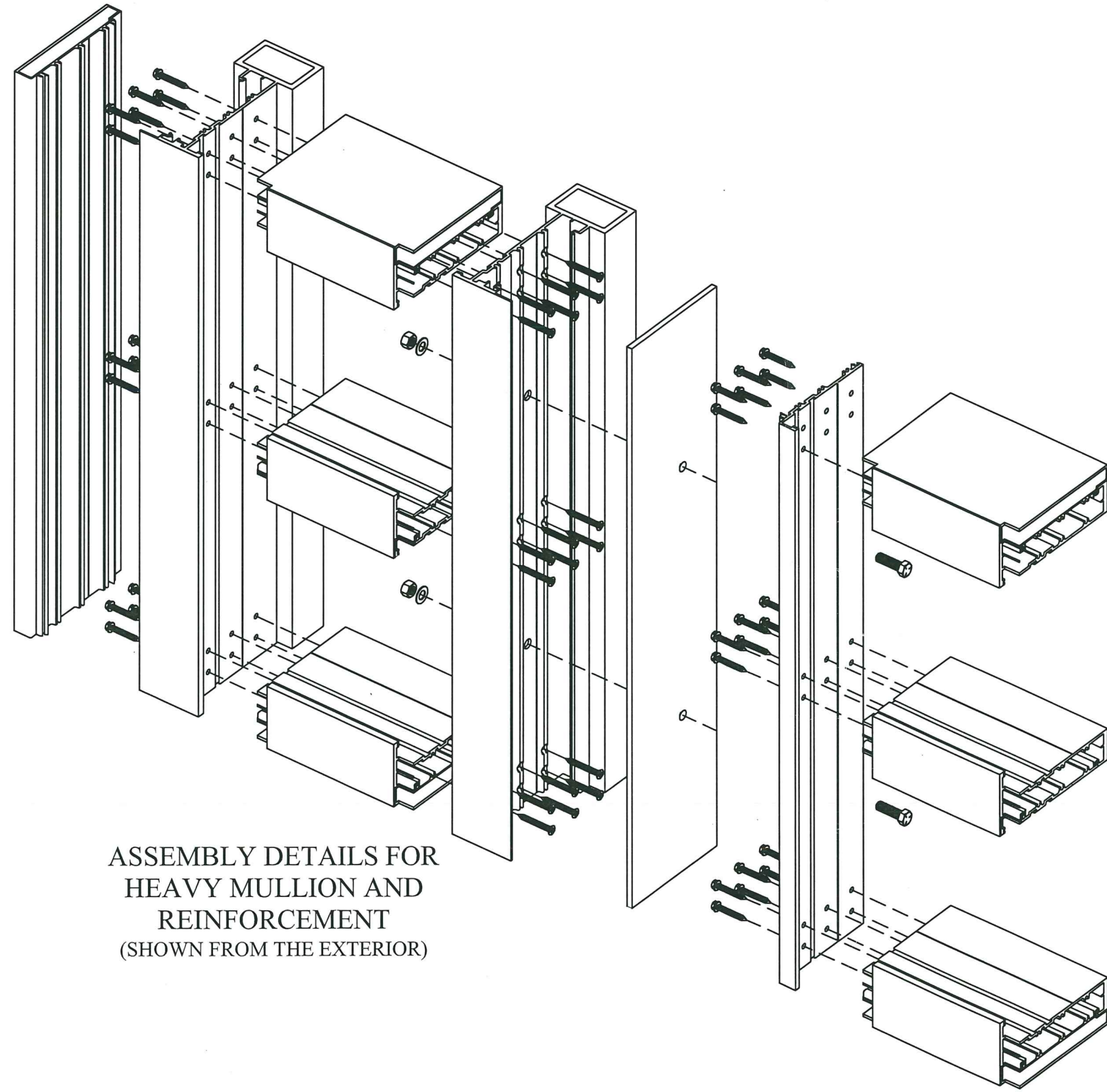

ASSEMBLY DETAILS FOR  
HEAVY MULLION AND  
REINFORCEMENT  
(SHOWN FROM THE EXTERIOR)

AUG 16 2021

**PRODUCT REVISED**  
as complying with the Florida  
Building Code  
NOA-No. **21-0823.02**  
Expiration Date: **02/21/2024**  
By: *Manuel Perez*  
Miami-Dade Product Control

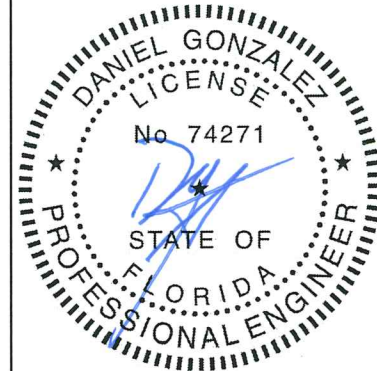

SERIES "AC0113"  
WINDOW WALL  
SYSTEM  
(SMI)  
Drawings No:  
CDM 2021-06  
Drawn by: AP  
Checked by: DG  
Date: 07/5/21  
Scale:  
SHEET No:  
7 of 7

NO.	DATE	BY	REVISION

**CDM**  
IMPACT SYSTEM  
8303 NW 27th Street, Suite 17, Doral, FL 33122 / Ph: 305-267-1011

**ACM**  
AM American Consulting, Inc.  
10300 SW 72nd Street, Suite 455, Miami, FL 33173  
Ph (786) 219-9490 / www.americanconsulting.com  
Cert. Authorization No. 31388