



DEPARTMENT OF REGULATORY AND ECONOMIC RESOURCES (RER)
BOARD AND CODE ADMINISTRATION DIVISION

NOTICE OF ACCEPTANCE (NOA)

MIAMI-DADE COUNTY
PRODUCT CONTROL SECTION
11805 SW 26 Street, Room 208
Miami, Florida 33175-2474
T (786) 315-2590 F (786) 315-2599
www.miamidade.gov/economy

Dryvit Systems, Inc.
One Energy Way
West Warwick, RI 02893

SCOPE:

This NOA is being issued under the applicable rules and regulations governing the use of construction materials. The documentation submitted has been reviewed and accepted by Miami-Dade County RER-Product Control Section to be used in Miami Dade County and other areas where allowed by the Authority Having Jurisdiction (AHJ).

This NOA shall not be valid after the expiration date stated below. The Miami-Dade County Product Control Section (In Miami Dade County) and/or the AHJ (in areas other than Miami Dade County) reserve the right to have this product or material tested for quality assurance purposes. If this product or material fails to perform in the accepted manner, the manufacturer will incur the expense of such testing and the AHJ may immediately revoke, modify, or suspend the use of such product or material within their jurisdiction. RER reserves the right to revoke this acceptance, if it is determined by Miami-Dade County Product Control Section that this product or material fails to meet the requirements of the applicable building code.

This product is approved as described herein and has been designed to comply with the Florida Building Code, including the High Velocity Hurricane Zone.

DESCRIPTION: Dryvit Outsulation X EIF System over 5/8” Gypsum Sheathing

APPROVAL DOCUMENT: Drawing No. **OXLSM**, titled “Outsulation® X System over 5/8” Gypsum Sheathing”, sheets 1 through 3 of 3, dated 09/19/2016, prepared by Dryvit Systems, Inc., signed and sealed by Scott Wolters, P.E. on 02/28/2017, bearing the Miami-Dade County Product Control renewal stamp with the Notice of Acceptance number and expiration date by the Miami-Dade County Product Control Section.

MISSILE IMPACT RATING: Large and Small Missile Impact Resistant.

LABELING: Each unit shall bear a permanent label with the manufacturer's name or logo, city, state and following statement: "Miami-Dade County Product Control Approved", unless otherwise noted herein. Each container (bucket or drum) needs to be labeled. Unit is further defined as each roll of reinforcing mesh.

RENEWAL of this NOA shall be considered after a renewal application has been filed and there has been no change in the applicable building code negatively affecting the performance of this product.

TERMINATION of this NOA will occur after the expiration date or if there has been a revision or change in the materials, use, and/or manufacture of the product or process. Misuse of this NOA as an endorsement of any product, for sales, advertising or any other purposes shall automatically terminate this NOA. Failure to comply with any section of this NOA shall be cause for termination and removal of NOA.

ADVERTISEMENT: The NOA number preceded by the words Miami-Dade County, Florida, and followed by the expiration date may be displayed in advertising literature. If any portion of the NOA is displayed, then it shall be done in its entirety.

INSPECTION: A copy of this entire NOA shall be provided to the user by the manufacturer or its distributors and shall be available for inspection at the job site at the request of the Building Official. This NOA **renews NOA # 21-0521.12** and consists of this page 1 and evidence pages E-1, E-2 and E-3, as well as approval document mentioned above.

The submitted documentation was reviewed by **Carlos M. Utrera, P.E.**



NOA No. 22-0124.04
Expiration Date: March 30, 2027
Approval Date: February 24, 2022
Page 1

NOTICE OF ACCEPTANCE: EVIDENCE SUBMITTED

1. EVIDENCE SUBMITTED UNDER NOA # 17-0112.04

A. DRAWINGS

1. Drawing No. **OXLSM**, titled “Outsulation ® X System over 5/8” Gypsum Sheathing”, sheets 1 through 3 of 3, dated 09/19/2016, prepared by Dryvit Systems, Inc., signed and sealed by Scott Wolters, P.E.

B. TESTS

1. Test reports on 1) Uniform Static Air Pressure Test, Loading per FBC TAS 202-94
2) Large Missile Impact Test per FBC, TAS 201-94
3) Cyclic Wind Pressure Loading per FBC, TAS 203-94
along with marked-up drawings and installation diagram of Dryvit Outsulation X EIF System over 5/8” Sheathing, prepared by Intertek/ATI, Test Report No. **G1213.02-550-18**, dated 10/28/2016, signed and sealed by Justin P. McDonald, P.E.

C. CALCULATIONS

1. Anchor verification calculations prepared by Wolters Engineering, dated 12/09/2016, signed and sealed by Scott Wolters, P.E.

D. QUALITY ASSURANCE

1. Miami-Dade Department of Regulatory and Economic Resources (RER)

E. MATERIAL CERTIFICATIONS

1. None.

F. STATEMENTS

1. Statement letter of code conformance to the 5th edition (2014) FBC issued by Wolters Engineering, dated 12/09/2016, signed and sealed by Scott Wolters, P.E.
2. Statement letter of no financial interest issued by Wolters Engineering, dated 12/09/2016, signed and sealed by Scott Wolters, P.E.



Carlos M. Utrera, P.E.
Product Control Examiner
NOA No. 22-0124.04
Expiration Date: March 30, 2027
Approval Date: February 24, 2022

NOTICE OF ACCEPTANCE: EVIDENCE SUBMITTED

2. EVIDENCE SUBMITTED UNDER NOA # 17-0807.18

A. DRAWINGS

1. None.

B. TESTS

1. None.

C. CALCULATIONS

1. None.

D. QUALITY ASSURANCE

1. Miami-Dade Department of Regulatory and Economic Resources (RER)

E. MATERIAL CERTIFICATIONS

1. None.

F. STATEMENTS

1. Statement letter of code conformance to the 6th Edition (2017) FBC issued by Wolters Engineering, dated 07/11/2017, signed and sealed by Scott Wolters, P.E.



Carlos M. Utrera, P.E.
Product Control Examiner
NOA No. 22-0124.04
Expiration Date: March 30, 2027
Approval Date: February 24, 2022

NOTICE OF ACCEPTANCE: EVIDENCE SUBMITTED

3. EVIDENCE SUBMITTED UNDER NOA # 21-0521.12

A. DRAWINGS

1. Drawing No. **OXL5M**, titled “Outsulation ® X System over 5/8” Gypsum Sheathing”, sheets 1 through 3 of 3, dated 09/19/2016, prepared by Dryvit Systems, Inc., signed and sealed by Scott Wolters, P.E. on 02/28/2017.

B. TESTS

1. None.

C. CALCULATIONS

1. None.

D. QUALITY ASSURANCE

1. Miami-Dade Department of Regulatory and Economic Resources (RER).

E. MATERIAL CERTIFICATIONS

1. None.

F. STATEMENTS

1. Statement letter of code conformance to the 7th Edition (2020) FBC issued by Wolters Engineering, Inc, dated May 10, 2021, signed and sealed by Scott Wolters, P.E.



Carlos M. Utrera, P.E.
Product Control Examiner
NOA No. 22-0124.04
Expiration Date: March 30, 2027
Approval Date: February 24, 2022

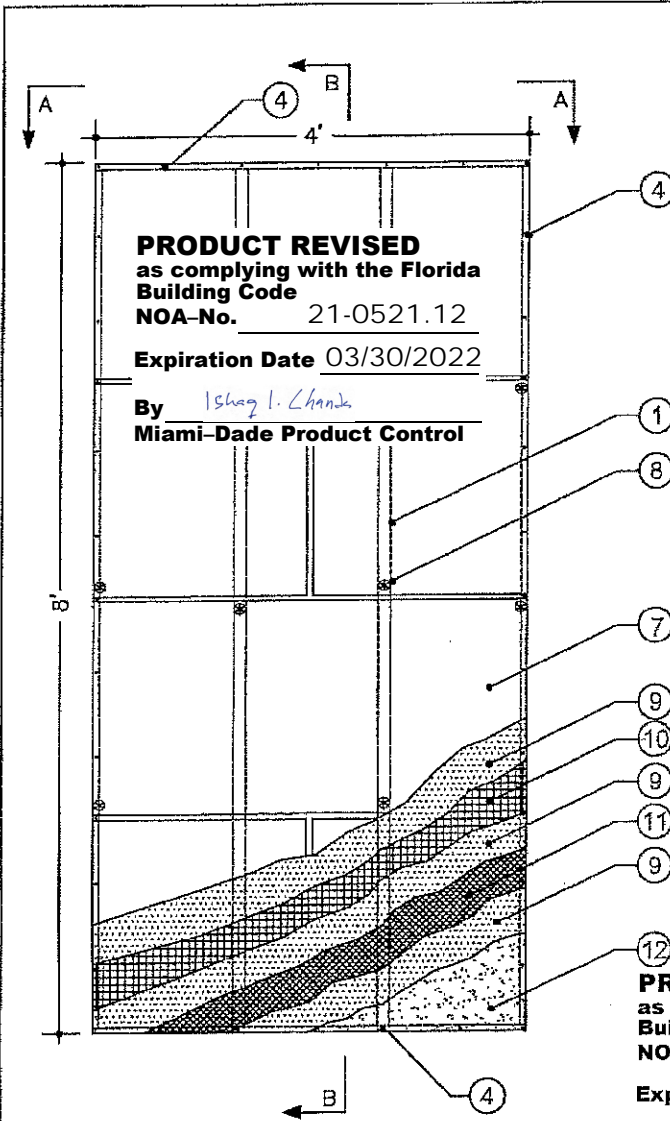

PRODUCT APPROVED
 as complying with the Florida
 Building Code
 NOA-No. **17-0112.04**
 Approval Date **03/30/2017**
 By *[Signature]*
 Miami-Dade Product Control

SECTION B-B

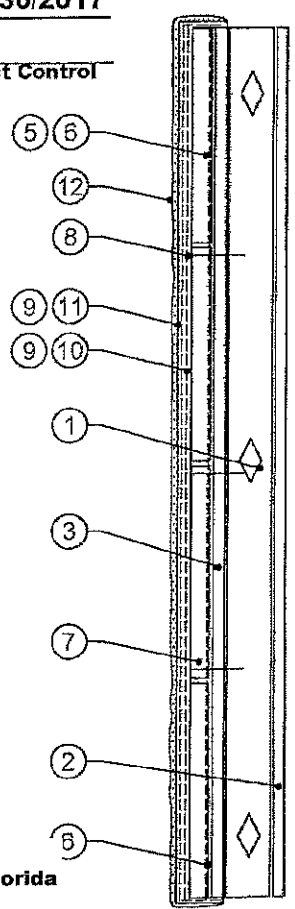

PRODUCT REVISED
 as complying with the Florida
 Building Code
 NOA-No. **17-0807.18**
 Expiration Date **03/30/2022**
 By *[Signature]*
 Miami-Dade Product Control

SCOTT WOLTERS
 FL PE# 62354
 WOLTERS ENGINEERING
 (COA# 27194)
 15211 97th ROAD N
 WEST PALM BEACH, FL 33411
 PH/FAX: (561) 225-1982

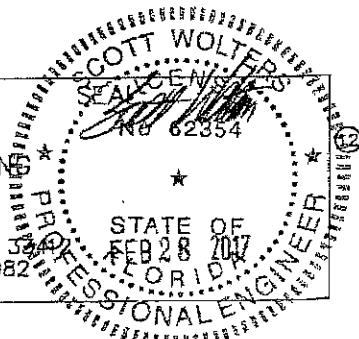

MATERIAL LIST

- ① MINIMUM 3 5/8" X 1 5/8" X 18 GAUGE STEEL STUDS AT 16" O.C. - SEE NOTES 4 AND 7
- ② MINIMUM 1/2" GYPSUM SHEATHING
- ③ MINIMUM 5/8" ASTM C1177 GLASS MAT FACED GYPSUM SHEATHING (EXP)
- ④ MINIMUM NO. 6 X 1 1/4" WAFER HEAD SELF TAPPING SCREWS SPACED 6" O.C.
- ⑤ DRYVIT BACKSTOP® NT WATER AND AIR BARRIER
- ⑥ ADHERE THE EXTRUDED INSULATION BOARD WITH DRYVIT'S GENESIS MIXTURE GENESIS IS A FIBER REINFORCED 100 PERCENT ACRYLIC BASED PRODUCT. GENESIS IS MIXED 1:1 BY WEIGHT WITH PORTLAND CEMENT AND WATER. THE ADHESIVE IS APPLIED WITH A 3/8" WIDE X 1/2" DEEP NOTCH TROWEL WITH NOTCHES SPACED A MAXIMUM OF 1 1/2" O.C. THE ADHESIVE SHALL BE APPLIED TO THE BACK OF THE INSULATION BOARD VERTICALLY.
- ⑦ MINIMUM 1" THICK EXTRUDED INSULATION BOARD MEETING THE FBC SECTION 2612 WITH A MIAMI DADE CO. NOA.
- ⑧ WINDLOCK WINDEVIL 2 FASTENERS - 4 PER 2'-0" X 4'-0" BOARD.
- ⑨ DRYVIT GENESIS® BASE COAT: GENESIS IS MIXED 1:1 BY WEIGHT WITH PORTLAND CEMENT AND WATER. GENESIS IS A 100 PERCENT POLYMER-BASED PRODUCT.
- ⑩ DRYVIT PANZER® 20 REINFORCING MESH: 20.5 OZ/SQ. YD FIBERGLASS REINFORCING MESH EMBEDDED IN DRYVIT BASE COAT. PANZER 20 MESH EDGES SHALL BE ABUTTED TIGHTLY. DO NOT OVERLAP.
- ⑪ DRYVIT STANDARD PLUS REINFORCING MESH: 6.0 OZ/SQ. YD FIBERGLASS REINFORCING MESH EMBEDDED IN THE DRYVIT BASE COAT. THE STANDARD PLUS REINFORCING MESH SHALL BE LAPPED A MINIMUM OF 2 1/2" AT ALL EDGES.

DRYVIT FINISH: A 100 PERCENT ACRYLIC BASED MATERIAL AVAILABLE IN VARIOUS TEXTURES.

PRODUCT RENEWED
 as complying with the Florida
 Building Code
 NOA-No. **22-0124.04**
 Expiration Date **03/30/2027**
 By *[Signature]*
 Miami-Dade Product Control

GENERAL NOTES

1. THE SYSTEM HAS BEEN DESIGNED IN ACCORDANCE WITH THE LATEST EDITION OF THE FLORIDA BUILDING CODE INCLUDING THE LATEST SUPPLEMENTS.
2. THIS SYSTEM HAS BEEN TESTED IN ACCORDANCE WITH DADE COUNTY PROTOCOLS TAS-201, TAS-202, AND TAS-203 FOR LARGE MISSILE IMPACT, STRUCTURAL AND CYCLIC TESTING.
3. THIS SYSTEM SHALL BE APPLIED BY A LICENSED PLASTERING CONTRACTOR FOLLOWING THIS NOTICE OF ACCEPTANCE THE RECOMMENDATION OF DRYVIT SYSTEMS, INC. AND THE APPLICABLE SECTIONS OF THE FLORIDA BUILDING CODE.
4. THE ENGINEER AND/OR ARCHITECT OF RECORD FOR EACH PROJECT USING THIS SYSTEM SHALL SIZE ALL STUD FRAMING TO ENSURE CONFORMANCE WITH STUD DEFLECTION AND STRESS LIMITATIONS AS REQUIRED BY ALL GOVERNING CODES AND THIS DOCUMENT.
5. INSULATION BOARDS SHALL BE POSITIONED IN A RUNNING BOND PATTERN.
6. ALL STUDS USED WITH THIS SYSTEM SHALL BE COMPLETELY SHEATHED AT THE INTERIOR FLANGE OR BRIDGED AT A MAXIMUM OF EVERY 5' OF STUD LENGTH OR AS SPECIFIED BY THE STUD MANUFACTURER.
7. ALL STEEL STUDS SHALL BE STRUCTURAL WITH 1 5/8" MINIMUM FLANGE WIDTH AND HAVE A MINIMUM YIELD STRENGTH OF 33000 PSI.
8. DETAILS ON SHEET 2 AND 3 OF 3 ARE TYPICAL AND SHOW INTENT TO PREVENT WATER INFILTRATION INTO AND BEHIND THIS SYSTEM. ALTERNATE DETAILS AND SPECIFIC CONDITIONS NOT COVERED BY THE TYPICAL DETAILS ARE THE RESPONSIBILITY OF THE LICENSED DESIGN PROFESSIONALS IN CONSULTATION WITH DRYVIT SYSTEMS, INC.

| |
|-----------------|
| DESIGN PRESSURE |
| ±93 PSF |

| | | |
|---|-------------------------|-------|
| DRYVIT SYSTEMS, INC. | | |
| One Energy Way West Warwick, Rhode Island | | |
| DWG. NO.: OXLSM | | |
| SHEET NO: 1 OF 3 | ISSUE DATE: 09/19/16 | REV / |
| OUTSULATION @ X SYSTEM OVER 5/8" GYPSUM SHEATHING | | |

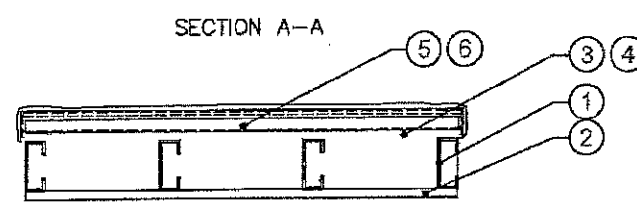

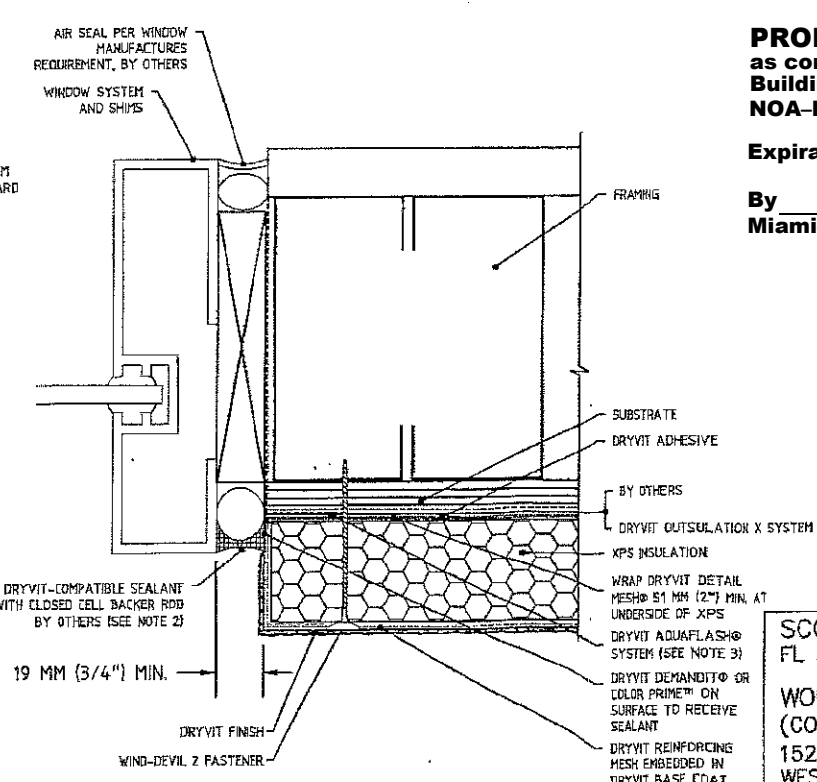
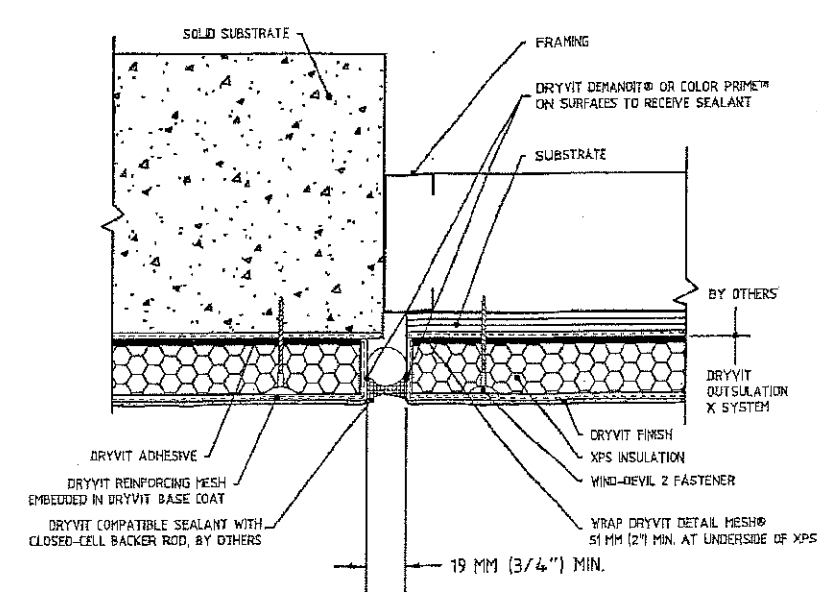
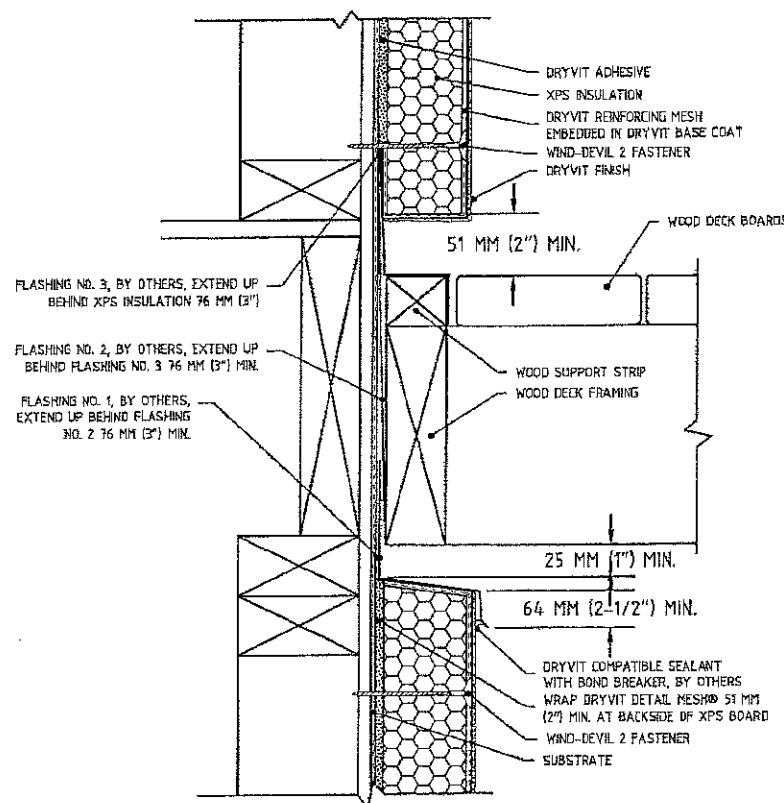

PRODUCT RENEWED
 as complying with the Florida Building Code
 NOA-No. 22-0124.04
 Expiration Date 03/30/2027
 By *[Signature]*
 Miami-Dade Product Control

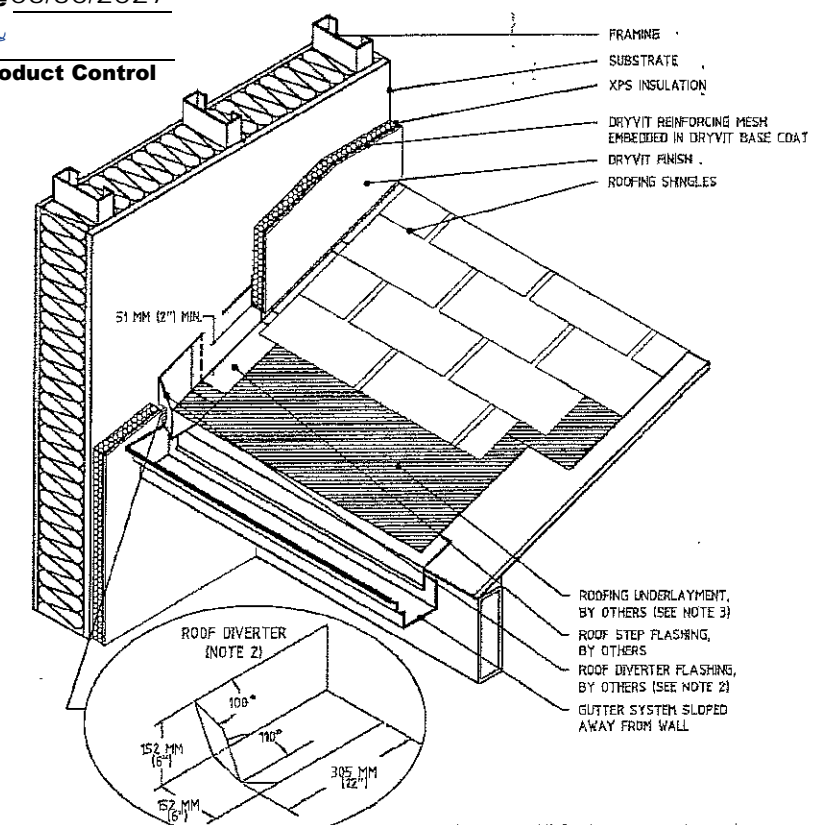

PRODUCT REVISED
 as complying with the Florida Building Code
 NOA-No. 21-0521.12
 Expiration Date 03/30/2022
 By *Ishag I. Chank*
 Miami-Dade Product Control

PRODUCT REVISED
 as complying with the Florida Building Code
 NOA-No. 17-0807.18
 Expiration Date 03/30/2022
 By *[Signature]*
 Miami-Dade Product Control

PRODUCT APPROVED
 as complying with the Florida Building Code
 NOA-No. 17-0112.04
 Approval Date 03/30/2017
 By *[Signature]*
 Miami-Dade Product Control

- Notes:
1. Gap wood sheathing edge and end joints in accordance with APA (American Plywood Association) recommendations.
 2. Seal Penetrations through flashing where attached to framing
 3. Distance of EIFS to deck varies with climate. Allow sufficient distance to prevent snow/ice and puddling water against system.
 4. Provide end dams where flashings terminate at ends of deck.
 5. Pressure treated wood (space from flashing or rout backside to provide drainage)

SCOTT WOLTERS
 FL PE# 62354
 WOLTERS ENGINEERING
 (COA# 27194)
 15211 97th ROAD N
 WEST PALM BEACH, FL 33411
 PH/FAX: (561) 225-1982

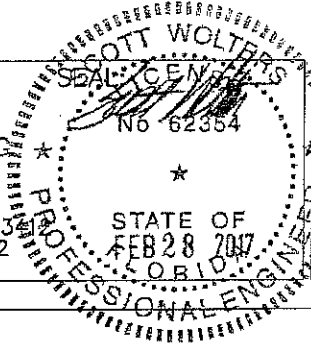

| | | | |
|--|------------------|----------------------|--|
| DRYVIT SYSTEMS, INC. One Energy Way West Warwick, Rhode Island | | | |
| DWG. NO.: OXLSM | SHEET NO: 2 OF 3 | ISSUE DATE: 09/19/16 | |
| OUTSULATION @ X SYSTEM OVER 5/8" GYPSUM SHEATHING | | | |

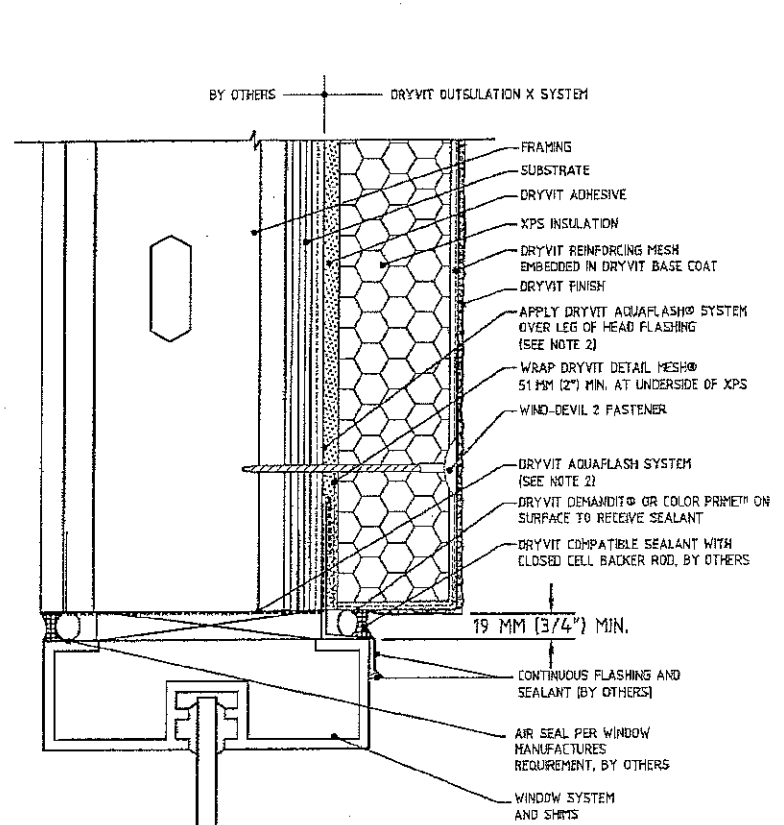

PRODUCT RENEWED
 as complying with the Florida
 Building Code
 NOA-No. 22-0124.04
 Expiration Date 03/30/2027
 By [Signature]
 Miami-Dade Product Control

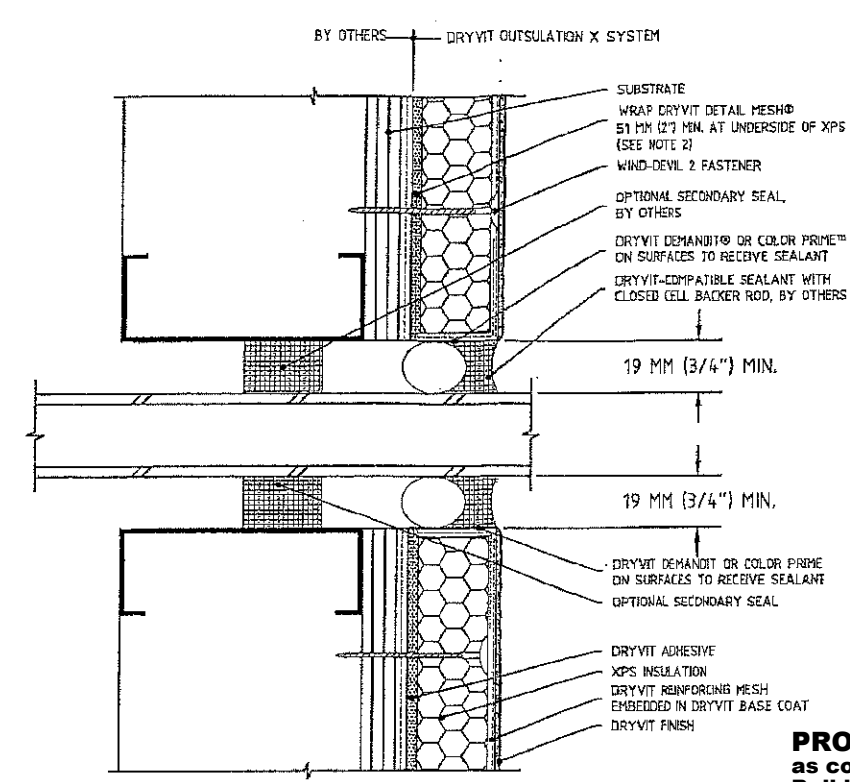

PRODUCT REVISED
 as complying with the Florida
 Building Code
 NOA-No. 21-0521.12
 Expiration Date 03/30/2022
 By [Signature]
 Miami-Dade Product Control

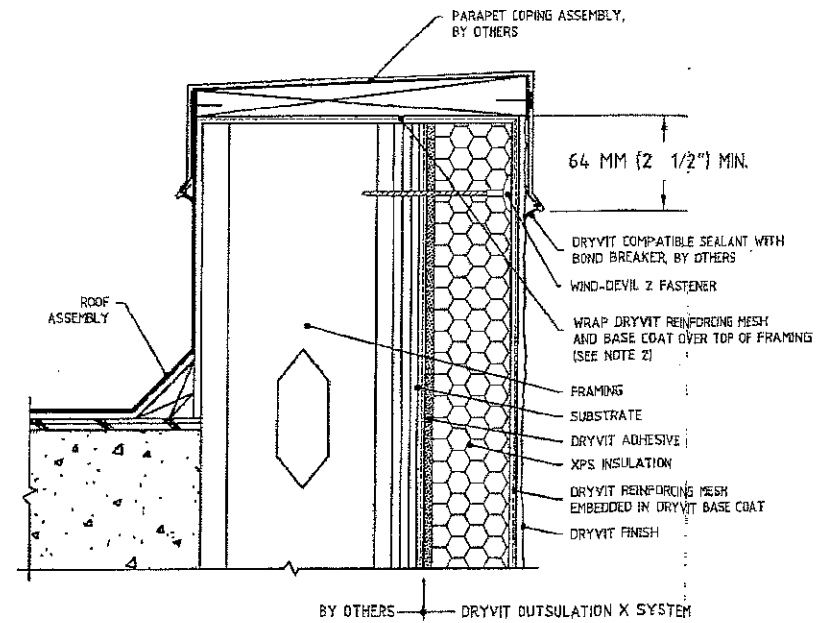

PRODUCT REVISED
 as complying with the Florida
 Building Code
 NOA-No. 17-0807.18
 Expiration Date 03/30/2022
 By [Signature]
 Miami-Dade Product Control

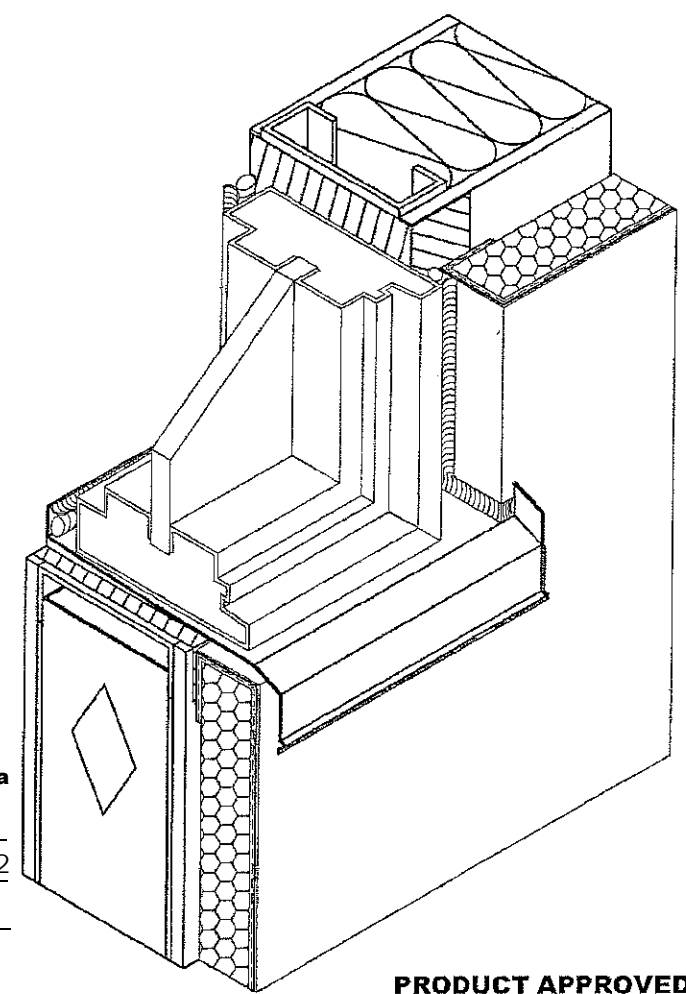

PRODUCT APPROVED
 as complying with the Florida
 Building Code
 NOA-No. 17-0112.04
 Approval Date 03/30/2017
 By [Signature]
 Miami-Dade Product Control

SCOTT WOLTERS
 FL PE# 62354
 WOLTERS ENGINEERING
 (COA# 27194)
 15211 97th ROAD N
 WEST PALM BEACH, FL 33413
 PH/FAX: (561) 225-1982

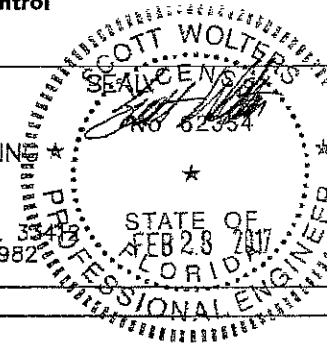

| | |
|---|-------------------------|
| DRYVIT SYSTEMS, INC. | |
| One Energy Way West Warwick, Rhode Island | |
| DWG. NO.: OXLSM | REV / |
| SHEET NO: 3 OF 3 | ISSUE DATE: 09/19/16 |
| OUTSULATION X SYSTEM OVER 5/8" GYPSUM SHEATHING | |