



DEPARTMENT OF REGULATORY AND ECONOMIC RESOURCES (RER)
BOARD AND CODE ADMINISTRATION DIVISION

MIAMI-DADE COUNTY
PRODUCT CONTROL SECTION

11805 SW 26 Street, Room 208

Miami, Florida 33175-2474

T (786) 315-2590 F (786) 315-2599

www.miamidade.gov/pera

NOTICE OF ACCEPTANCE (NOA)

Terracotagres USA LLC
8115 NW 74th Ave
Medley, FL. 33166

SCOPE:

This NOA is being issued under the applicable rules and regulations governing the use of construction materials. The documentation submitted has been reviewed and accepted by Miami-Dade County RER - Product Control Section to be used in Miami Dade County and other areas where allowed by the Authority Having Jurisdiction (AHJ).

This NOA shall not be valid after the expiration date stated below. The Miami-Dade County Product Control Section (in Miami-Dade County) and/or the AHJ (in areas other than Miami-Dade County) reserve the right to have this product or material tested for quality assurance purposes. If this product or material fails to perform in the accepted manner, the manufacturer will incur the expense of such testing and the AHJ may immediately revoke, modify, or suspend the use of such product or material within their jurisdiction. RER reserves the right to revoke this acceptance, if it is determined by Miami-Dade County Product Control Section that this product or material fails to meet the requirements of the applicable building code.

This product is approved as described herein, and has been designed to comply with the Florida Building Code including the High Velocity Hurricane Zone of the Florida Building Code.

DESCRIPTION: Brastile "S" Clay Roof Tile

LABELING: Each unit shall bear a permanent label with the manufacturer's name or logo, city, state and following statement: "Miami-Dade County Product Control Approved", unless otherwise noted herein.

RENEWAL of this NOA shall be considered after a renewal application has been filed and there has been no change in the applicable building code negatively affecting the performance of this product.

TERMINATION of this NOA will occur after the expiration date or if there has been a revision or change in the materials, use, and/or manufacture of the product or process. Misuse of this NOA as an endorsement of any product, for sales, advertising or any other purposes shall automatically terminate this NOA. Failure to comply with any section of this NOA shall be cause for termination and removal of NOA.

ADVERTISEMENT: The NOA number preceded by the words Miami-Dade County, Florida, and followed by the expiration date may be displayed in advertising literature. If any portion of the NOA is displayed, then it shall be done in its entirety.

INSPECTION: A copy of this entire NOA shall be provided to the user by the manufacturer or its distributors and shall be available for inspection at the job site at the request of the Building Official.

This NOA renews and revises NOA# 16-1213.03 and consists of pages 1 through 7.
The submitted documentation was reviewed by Alex Tigera.



NOA No.: 22-0301.03
Expiration Date: 03/02/27
Approval Date: 04/07/22
Page 1 of 7

ROOFING ASSEMBLY APPROVAL

Category: Roofing
Sub Category: Roofing Tiles
Material: Clay

1. SCOPE

This approves a roofing system using **Brastile “S” Clay Roof Tile** manufactured by **Terracotagres Ceramica LTDA** in **Sangao SC Brazil** and distributed by Miami Terracota LLC., as described in Section 2 of this Notice of Acceptance. For locations where the pressure requirements, as determined by applicable Building Code does not exceed the design pressure values obtained by calculations in compliance with RAS 127 using the values listed in section 4 herein. The attachment calculations shall be done as a moment based system.

2. PRODUCT DESCRIPTION

<u>Manufactured by Applicant</u>	<u>Dimensions</u>	<u>Test Specifications</u>	<u>Product Description</u>
Brastile “S” Clay Roof Tile	L = 20.4” W = 12” 0.38” thick nominal 3.5” high	TAS 112 Type 1 Grade 3	High profile clay roof tile. For direct deck adhesive set applications with the nominal interlocking headlap.
Trim Pieces	Length: varies Width: varies varying thickness	TAS 112	Accessory trim, clay roof pieces for use at hips, rakes, ridges and valley terminations manufactured for each tile profile.

2.1 PRODUCTS MANUFACTURED BY OTHERS

<u>Product Name</u>	<u>Product Description</u>	<u>Manufacturer (With Current NOA)</u>
ICP Adhesives Polyset AH-160	Two component polyurethane foam adhesive.	ICP Adhesives and Sealants, Inc.
TILE BOND™ Roof Tile Adhesive	Single component polyurethane foam roof tile adhesive.	DuPont de Nemours, Inc.
“Tile Tite” Roof Tile Mortar	Premixed, pre-bagged roof tile mortar.	Premix-Marbletite Manufacturing Co.
“Quikrete” Roof Tile Mortar, FL-15	Premixed, pre-bagged gray roof tile mortar.	The Quikrete Companies, Inc.

2.2 MANUFACTURING LOCATION

2.2 Sangao SC Brazil



NOA No.: 22-0301.03
Expiration Date: 03/02/27
Approval Date: 04/07/22
Page 2 of 7

2.3 SUBMITTED EVIDENCE:

<u>Test Agency</u>	<u>Test Identifier</u>	<u>Test Name/Report</u>	<u>Date</u>
Redland Technologies	7161-03 Appendix III	PA 102 & PA 102(A)	Dec. 1991
	Letter	PA 108 (Nail-On)	Aug. 1994
	P09647-01	PA 108 (Mortar Set)	July 1994
	P0402	Withdrawal Resistance Testing of screw vs. smooth shank nails	Sept. 1993
The Center for Applied Engineering, Inc.	94-083	PA 101 (Adhesive Set)	April 1994
	94-084	PA 101 (Mortar Set)	May 1994
	25-7094-(3, 6 & 9)	PA 102	Oct. 1994
	25-7120-(1 & 2)	PA 102	Nov. 1994
	25-7183-(3 & 4)	PA 102	Feb. 1995
	25-7214-(3, 4, &7)	PA 102	March, 1995
	25-7804-4	PA 102	Sept. 1996
Celotex Corporation Testing Services	520111-3	PA 101	Dec. 1998
	520191-2-1	PA 101	March 1999
Walker Engineering, Inc.	Calculations	25-7094	February 1996
	Calculations	25-7496	April 1996
	Calculations	25-7584	December 1996
	Calculations	25-7804b-8	December 1996
	Calculations	25-7804-4 & 5	December 1996
	Calculations	25-7848-6	December 1996
	Calculations	25-7183	March 1995
ATL of South Florida	RT0429.03-21	ASTM C 1167	05/04/21
	RT1110.02-16	TAS 101	12/06/16
	RT0208.01-22	TAS 101	02/18/22
	RT0217.01-22	TAS 101	02/22/22

3. LIMITATIONS:

- 3.1 Fire classification is not part of this acceptance.
- 3.2 For mortar or adhesive set tile applications, a static field uplift test in accordance with TAS 106 may required, refer to applicable building code.
- 3.3 Applicant shall retain the services of a Miami-Dade County Certified Laboratory to perform quarterly test in accordance with TAS 112, appendix 'A'. Such testing shall be submitted to the Regulatory and Economic Development Department – Product Control Section for review.
- 3.4 Minimum underlayment shall be in compliance with the applicable Roofing Applications Standards listed section 4.1 herein.
- 3.5 30/90 hot mopped underlayment applications may be installed perpendicular to the roof slope unless stated otherwise by the underlayment material manufacturers published literature.
- 3.6 This acceptance is for wood deck applications. Minimum deck requirements shall be in compliance with applicable building code.
- 3.7 May be installed on sloped 7:12 or greater.

4. INSTALLATION

4.1 Brastile "S" Clay Roof Tile and its components shall be installed in strict compliance with Roofing Application Standard RAS 118, RAS 119, and RAS 120

4.2 Data For Attachment Calculations.

Table 1: Average Weight (W) and Dimensions (l x w)

Tile Profile	Weight-W (lbf)	Length-l (ft)	Width-w (ft)
Brastile "S"	9.3	1.70	1

Table 2: Aerodynamic Multipliers - λ (ft³)

Tile Profile	λ (ft ³) Batten Application	λ (ft ³) Direct Deck Application
Brastile "S"	N/A	0.35

Table 3: Restoring Moments due to Gravity - M_g (ft-lbf)

Tile Profile	2":12"		3":12"		4":12"		5":12"		6":12"		7":12" or greater	
	Battens	Direct Deck	Battens	Direct Deck	Battens	Direct Deck	Battens	Direct Deck	Battens	Direct Deck	Battens	Direct Deck
Brastile "S"	N/A	7.7	N/A	7.6	N/A	7.45	N/A	7.27	N/A	7.07	N/A	6.85

Table 4: Attachment Resistance Expressed as a Moment - M_r (ft-lbf) for Mechanically Attached Systems

Tile Profile	Fastener Type	Direct Deck (min 15/32" plywood)	Direct Deck (min. 19/32" plywood)	Battens
Brastile "S"	2-10d Ring Shank Nails	28.6	41.2	N/A
	1-10d Smooth or Screw Shank Nail	5.1	6.8	N/A
	2-10d Smooth or Screw Shank Nails	6.9	9.2	N/A
	1 #8 Screw	20.7	20.7	N/A
	2 #8 Screw	43.2	43.2	N/A
	1-10d Smooth or Screw Shank Nail (Field Clip)	23.1	23.1	N/A
	1-10d Smooth or Screw Shank Nail (Eave Clip)	29.3	29.3	N/A
	2-10d Smooth or Screw Shank Nails (Field Clip)	27.6	27.6	N/A
2-10d Smooth or Screw Shank Nails (Eave Clip)	38.1	38.1	N/A	

**Table 5: Attachment Resistance Expressed as a Moment - M_r (ft-lbf)
for Mechanically Attached Systems**

Tile Profile	Fastener Type	Direct Deck (min 15/32" plywood)	Direct Deck (min. 19/32" plywood)	Battens
Brastile "S"	2-10d Ring Shank Nails ¹	33.1	48.1	45.2

¹ Installation with a 4" tile headlap and fasteners are located a min. of 2½" from head of tile.

**Table 6: Attachment Resistance Expressed as a Moment M_r (ft-lbf)
for Two Paddy Adhesive Set Systems**

Tile Profile	Tile Application	Minimum Attachment Resistance
Brastile "S"	TILE BOND Roof Tile Adhesive	29.3 ²
	Polyset AH-160	29.3 ³

¹ See manufactures component approval for installation requirements.
² TILE BOND™ Roof Tile Adhesive; Medium paddy placement of 10.7 grams
³ ICP Adhesives and Sealants, Inc.'s ICP Adhesives Polyset AH-160; Medium paddy placement of 8 grams.

**Table 7: Attachment Resistance Expressed as a Moment - M_r (ft-lbf)
for Single Paddy Adhesive Set Systems**

Tile Profile	Tile Application	Minimum Attachment Resistance
Brastile "S"	Polyset AH-160	66.5 ⁴
	Polyset AH-160	61.8 ⁵
	Polyset AH-160	38.7 ⁶
	TILE BOND Roof Tile Adhesive	44.5 ⁶

⁴ ICP Adhesives and Sealants, Inc.'s ICP Adhesives Polyset AH-160; Large paddy placement of 63 grams
⁵ ICP Adhesives and Sealants, Inc.'s ICP Adhesives Polyset AH-160; Large paddy placement of 42 grams
⁶ ICP Adhesives and Sealants, Inc.'s ICP Adhesives Polyset AH-160; Medium paddy placement of 24 grams
⁷ TILE BOND™ Roof Tile Adhesive; Medium paddy placement of 38 grams

**Table 8: Attachment Resistance Expressed as a Moment - M_r (ft-lbf)
for Mortar Set Systems**

Tile Profile	Tile Application	Attachment Resistance
Brastile "S"	Mortar Set ⁸	24.5

⁸ See specific mortar manufacturers Notice of Acceptance



5. LABELING

- 5.1 All tiles shall bear the imprint or identifiable marking of the manufacturer's name or logo as detailed below, or following statement: "Miami-Dade County Product Control Approved".



BRASTILE
Sangão – SC
Made in Brazil

LABEL FOR BRASTILE “S” CLAY ROOF TILE
(LOCATED ON THE SIDE OF TILE)

6. BUILDING PERMIT REQUIREMENTS:

- 6.1 Application for building permit shall be accompanied by copies of the following:
- 6.1.1 This Notice of Acceptance.
 - 6.1.2 Any other documents required by Building Official or Applicable building code in order to properly evaluate the installation of this system.



NOA No.: 22-0301.03
Expiration Date: 03/02/27
Approval Date: 04/07/22
Page 6 of 7

PROFILE DRAWING

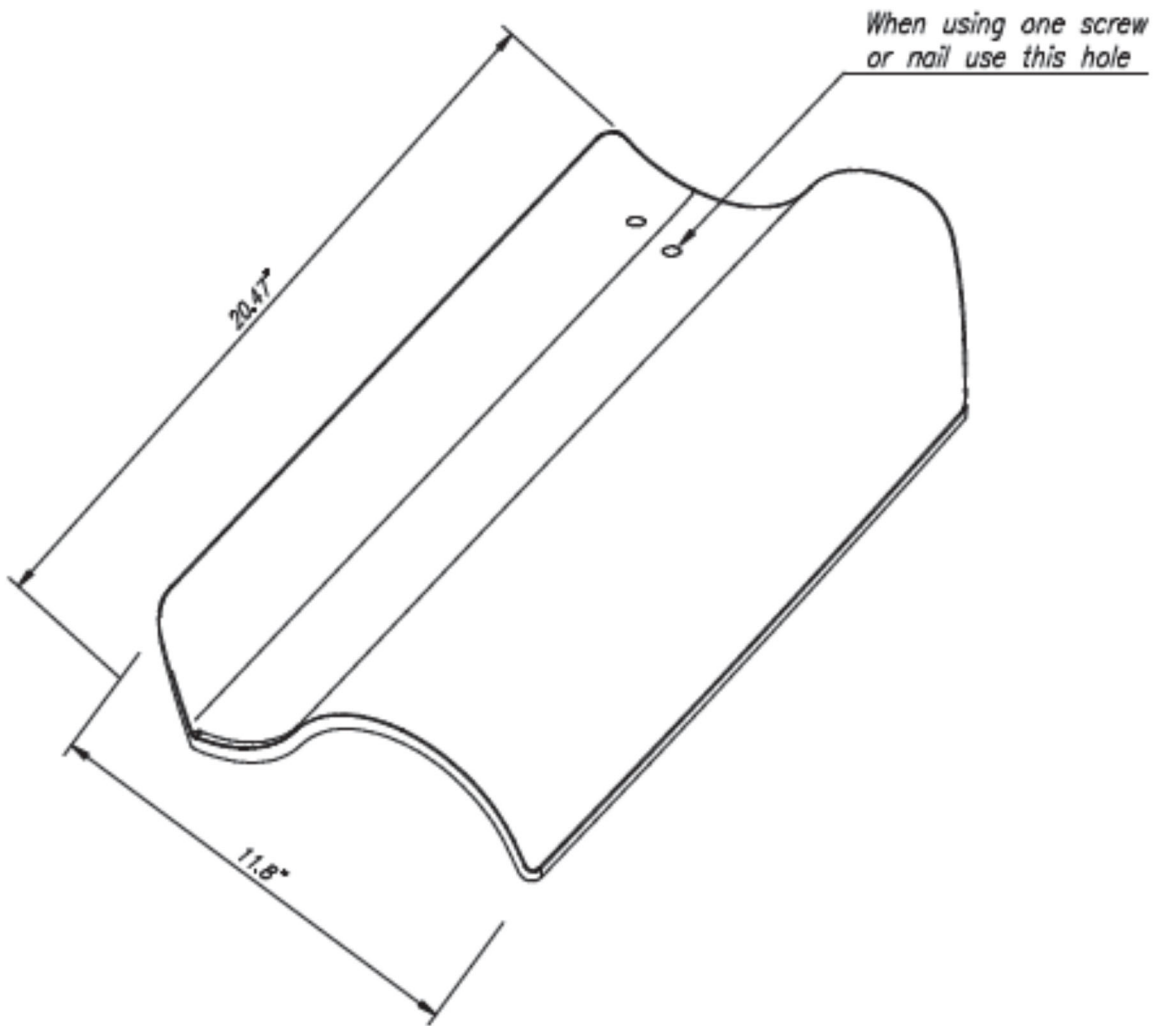

TOPTELHA M14 SPANISH 'S' CLAY ROOF TILE

END OF THIS ACCEPTANCE