



DEPARTMENT OF REGULATORY AND ECONOMIC RESOURCES (RER)
BOARD AND CODE ADMINISTRATION DIVISION

NOTICE OF ACCEPTANCE (NOA)

MIAMI-DADE COUNTY
PRODUCT CONTROL SECTION

11805 SW 26 Street, Room 208
Miami, Florida 33175-2474
T (786) 315-2590 F (786) 315-2599

www.miamidade.gov/economy

Westlake Royal Roofing, LLC
7575 Irvine Center Drive, Suite 100
Irvine, CA 92618

SCOPE:

This NOA is being issued under the applicable rules and regulations governing the use of construction materials. The documentation submitted has been reviewed and accepted by Miami-Dade County RER -Product Control Section to be used in Miami-Dade County and other areas where allowed by the Authority Having Jurisdiction (AHJ).

This NOA shall not be valid after the expiration date stated below. The Miami-Dade County Product Control Section (in Miami-Dade County) and/or the AHJ (in areas other than Miami-Dade County) reserve the right to have this product or material tested for quality assurance purposes. If this product or material fails to perform in the accepted manner, the manufacturer will incur the expense of such testing and the AHJ may immediately revoke, modify, or suspend the use of such product or material within their jurisdiction. RER reserves the right to revoke this acceptance, if it is determined by Miami-Dade County Product Control Section that this product or material fails to meet the requirements of the applicable building code.

This product is approved as described herein, and has been designed to comply with the Florida Building Code including the High Velocity Hurricane Zone of the Florida Building Code.

DESCRIPTION: Plantation Roof Tile

LABELING: Each unit shall bear a permanent label with the manufacturer's name or logo, city, state and following statement: "Miami-Dade County Product Control Approved", unless otherwise noted herein.

RENEWAL of this NOA shall be considered after a renewal application has been filed and there has been no change in the applicable building code negatively affecting the performance of this product.

TERMINATION of this NOA will occur after the expiration date or if there has been a revision or change in the materials, use, and/or manufacture of the product or process. Misuse of this NOA as an endorsement of any product, for sales, advertising or any other purposes shall automatically terminate this NOA. Failure to comply with any section of this NOA shall be cause for termination and removal of NOA.

ADVERTISEMENT: The NOA number preceded by the words Miami-Dade County, Florida, and followed by the expiration date may be displayed in advertising literature. If any portion of the NOA is displayed, then it shall be done in its entirety.

INSPECTION: A copy of this entire NOA shall be provided to the user by the manufacturer or its distributors and shall be available for inspection at the job site at the request of the Building Official.

This NOA revises NOA# 21-0420.07 and consists of pages 1 through 7.
The submitted documentation was reviewed by Alex Tigera.



NOA No.: 22-0331.15
Expiration Date: 12/08/25
Approval Date: 08/11/22
Page 1 of 7

ROOFING ASSEMBLY APPROVAL

Category: Roofing
Sub-Category: Roofing Tiles
Material: Concrete

1. SCOPE

This approves a roofing system using **Plantation Concrete Roof Tile**, as manufactured by Westlake Royal Roofing, LLC in Okeechobee, FL as described in Section 2 of this Notice of Acceptance, designed to comply with the Florida Building Code for High Velocity Hurricane Zone. For use in locations where the pressure requirements, as determined by applicable Building Code, do not exceed the design pressure values obtain by calculations in compliance with RAS 127 using the values listed in section 4 herein. The attachment calculations shall be prepared as a moment based system.

2. PRODUCT DESCRIPTION

<u>Manufactured by Applicant</u>	<u>Dimensions</u>	<u>Test Specifications</u>	<u>Product Description</u>
Plantation Tile	Length: 16½" Width: 13"	TAS 112	Flat profile concrete roof tile, Type 3a Interlocking, Class III; for direct deck or battened nail-on, mortar or adhesive set applications.
Trim Pieces	L = varies W = varies Varying thickness	TAS 112	Accessory trim, concrete roof pieces for use at hips, rakes, ridges and valley terminations. Manufactured for each tile profile.

2.1. MANUFACTURING LOCATION

1. Okeechobee, FL

2.2 PRODUCTS MANUFACTURED BY OTHERS

<u>Product Name</u>	<u>Product Description</u>	<u>Manufacturer (With Current NOA)</u>
ICP Adhesives Polyset® AH-160	Two component polyurethane foam adhesive.	ICP Adhesives and Sealants, Inc.
TILE BOND™ Roof Tile Adhesive	Single component polyurethane foam roof tile adhesive.	The Dow Chemical Company
Touch ‘N Seal StormBond® 2 Two-Component Polyurethane Roof Tile Adhesive	Two component polyurethane foam adhesive.	DAP Foam, Inc.
Touch ‘N Seal StormBond® One Component Polyurethane Roof Tile Adhesive	One component polyurethane foam adhesive.	DAP Foam, Inc.
Quikrete® Roof Tile Mortar, FL-15	Premixed, pre-bagged gray roof tile mortar.	The Quikrete Companies, Inc.



NOA No.: 22-0331.15
Expiration Date: 12/08/25
Approval Date: 08/11/22
Page 2 of 7

2.3 SUBMITTED EVIDENCE:

<u>Test Agency</u>	<u>Test Identifier</u>	<u>Test Name/Report</u>	<u>Date</u>
American Test Lab of South Florida	RT0624.05-14	TAS 112	07/03/14
	RT0817.07-20	TAS 112	08/14/20
Redland Technologies	7161-03 Appendix III	Static Uplift Testing PA 102 & PA 102(A)	Dec. 1991
The Center for Applied Engineering, Inc.	94-060B	Static Uplift Testing PA 101 (Adhesive Set)	March 1994
	94-084	Static Uplift Testing PA 101 (Mortar Set)	May 1994
Redland Technologies	7161-03 Appendix II Letter Dated Aug. 1, 1994	Wind Tunnel Testing PA 108 (Nail-On)	Dec. 1991
		Wind Tunnel Testing PA 108 (Nail-On)	Aug. 1994
	P0631-01	Wind Tunnel Testing PA 108 (Mortar Set)	July 1994
	P0402	Withdrawal Resistance Testing of screw vs. smooth shank nails	Sept. 1993
The Center for Applied Engineering, Inc.	Project No. 307025 Test #MDC-76	Wind Driven Rain PA 100	Oct. 1994
Walker Engineering, Inc.	Calculations	Aerodynamic Multiplier	March 1999
	Calculations	25-7183	April 1999
		25-7094	March 1995
		25-7496	February 1996
	Calculations	25-7584	April 1996
		25-7804b-8 25-7804-4 & 5 25-7848-6	December 1996
	Calculations	Two Patty Adhesive Set System	April 1999
Farabaugh Engineering and Testing Inc.	T295-11	TAS-108	10/05/11
	T306-11	TAS-108	10/04/11
	T279-11	TAS-108	09/23/11
PRI Construction Material Technologies	DAPF-004-02-08	TAS 101	07/26/18
	DAPF-004-02-09	TAS 101	07/26/18
	DAPF-004-02-10	TAS 101	07/26/18
	2002T0003.05	TAS 101	11/06/20



3. LIMITATIONS

- 3.1 Fire classification is not part of this acceptance.
- 3.2 For mortar or adhesive set tile applications, a static field uplift test shall be performed in accordance with TAS 106.
- 3.3 Applicant shall retain the services of a Miami-Dade County Certified Laboratory to perform quarterly test in accordance with TAS 112, appendix 'A'. Such testing shall be submitted to the Miami-Dade Product Control office for review.
- 3.4 Minimum underlayment shall be in compliance with the applicable Roofing Applications Standards listed section 4.1 herein.
- 3.5 Minimum 4/12 slope requirement for mechanically attached tiles.
- 3.6 30/90 hot mopped underlayment applications may be installed perpendicular to the roof slope unless stated otherwise by the underlayment material manufacturers published literature.
- 3.7 This acceptance is for wood deck applications. Minimum deck requirements shall be in compliance with applicable building code.
- 3.8 All products listed herein shall have a quality assurance audit in accordance with the Florida Building Code and Rule 61G20-3 of the Florida Administrative Code.

4. INSTALLATION

- 4.1 **Plantation Roof Tile** and its components shall be installed in strict compliance with Roofing Application Standard RAS 118, RAS 119 and RAS 120.
- 4.2 Data For Attachment Calculations

Table 1: Average Weight (W) and Dimensions (l x w)			
Tile Profile	Weight-W (lbf)	Length-l (ft)	Width-w (ft)
Plantation Tile	11.6	1.375	1.08

Table 2: Aerodynamic Multipliers - λ (ft ³)		
Tile Profile	λ (ft ³) Batten Application	λ (ft ³) Direct Deck Application
Plantation Tile	0.267	0.289

Table 3: Restoring Moments due to Gravity - M_g (ft.-lbf)												
Tile Profile	2": 12"		3": 12"		4": 12"		5": 12"		6": 12"		Greater than 7": 12"	
	Battens	Direct Deck	Battens	Direct Deck	Battens	Direct Deck	Battens	Direct Deck	Battens	Direct Deck	Battens	Direct Deck
Plantation Tile	N/A	7.91	N/A	7.79	6.75	7.67	6.61	7.52	6.44	7.32	6.26	7.04



**Table 4: Attachment Resistance Expressed as a Moment - M_r (ft-lbf)
For Nail-On Systems**

Tile Profile	Fastener Type	Direct Deck (Min 15/32" plywood)	Direct Deck (Min. 19/32" plywood)	Battens
Plantation Tile	2-10d Ring Shank Nails	30.9	38.1	17.2
	1-10d Smooth or Screw Shank Nail	7.3	9.8	4.9
	2-10d Smooth or Screw Shank Nails	14.0	18.8	7.4
	1 #8 Screw	30.8	30.8	18.2
	2 #8 Screw	51.7	51.7	24.4
	1-10d Smooth or Screw Shank Nail (Field Clip)	24.3	24.3	24.2
	1-10d Smooth or Screw Shank Nail (Eave Clip)	19.0	19.0	22.1
	2-10d Smooth or Screw Shank Nails (Field Clip)	35.5	35.5	34.8
	2-10d Smooth or Screw Shank Nails (Eave Clip)	31.9	31.9	32.2
	2-10d Ring Shank Nails ¹	50.3	65.5	48.3

¹ Installation with a 4" tile headlap and fasteners are located a minimum of 2½" from the head of tile.

**Table 5: Attachment Resistance Expressed as a Moment M_r (ft-lbf)
for Two Paddy Adhesive² Set Systems**

Tile Profile	Tile Application	Minimum Attachment Resistance
Plantation Tile	TILE BOND™ Roof Tile Adhesive	31.3 ³
	ICP Adhesives Polyset® AH-160	31.3 ⁴
	Touch 'N Seal StormBond® 2	45 ⁵
	Touch 'N Seal StormBond®	76 ⁶

² See foam adhesive manufacturer's component approval for installation requirements

³ Medium paddy weight of 13.9 grams per paddy of TILE BOND™ Roof Tile Adhesive

⁴ Medium paddy weight of 8 grams per paddy of Polyset® AH-160

⁵ Medium paddy weight of 8 grams per paddy of Touch 'N Seal StormBond® 2

⁶ Medium paddy weight of 18.7 grams between tile and underlayment, paddy weight of 10.5 grams on overlap of tile of Touch 'N Seal StormBond® (one-component)



**Table 6: Attachment Resistance Expressed as a Moment - M_f (ft-lbf)
for Single Paddy Adhesive Set Systems**

Tile Profile	Tile Application	Minimum Attachment Resistance
Plantation Tile	ICP Adhesives Polyset® AH-160	118.9 ⁷
	ICP Adhesives Polyset® AH-160	40.4 ⁸
	Touch 'N Seal StormBond® 2	73 ⁹
	Touch 'N Seal StormBond® 2	48 ¹⁰

- 7 Large paddy weight of 45 grams of Polyset® AH-160
- 8 Medium paddy weight of 24 grams of Polyset® AH-160
- 9 Large paddy weight of 45 grams of Touch 'N Seal StormBond® 2
- 10 Medium paddy weight of 24 grams of Touch 'N Seal StormBond® 2

**Table 7: Attachment Resistance Expressed as a Moment - M_f (ft-lbf)
for Mortar Set Systems**

Tile Profile	Tile Application	Attachment Resistance
Plantation Tile	Mortar Set ⁶	39.0

See specific mortar manufacturer's Notice of Acceptance.

5. LABELING

All tiles shall bear the imprint or identifiable marking of the manufacturer's name or logo as seen below or following statement: "Miami-Dade County Product Control Approved".

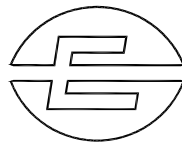

OR



PLANTATION ROOF TILE LABEL (LOCATED ON UNDERSIDE OF TILE)

6. BUILDING PERMIT REQUIREMENTS:

- 6.1 Application for building permit shall be accompanied by copies of the following:
 - 6.1.1 This Notice of Acceptance.
 - 6.1.2 Any other documents required by Building Official or Applicable building code in order to properly evaluate the installation of this system.



NOA No.: 22-0331.15
 Expiration Date: 12/08/25
 Approval Date: 08/11/22
 Page 6 of 7

PROFILE DRAWING

PLANTATION FLAT CONCRETE TILE

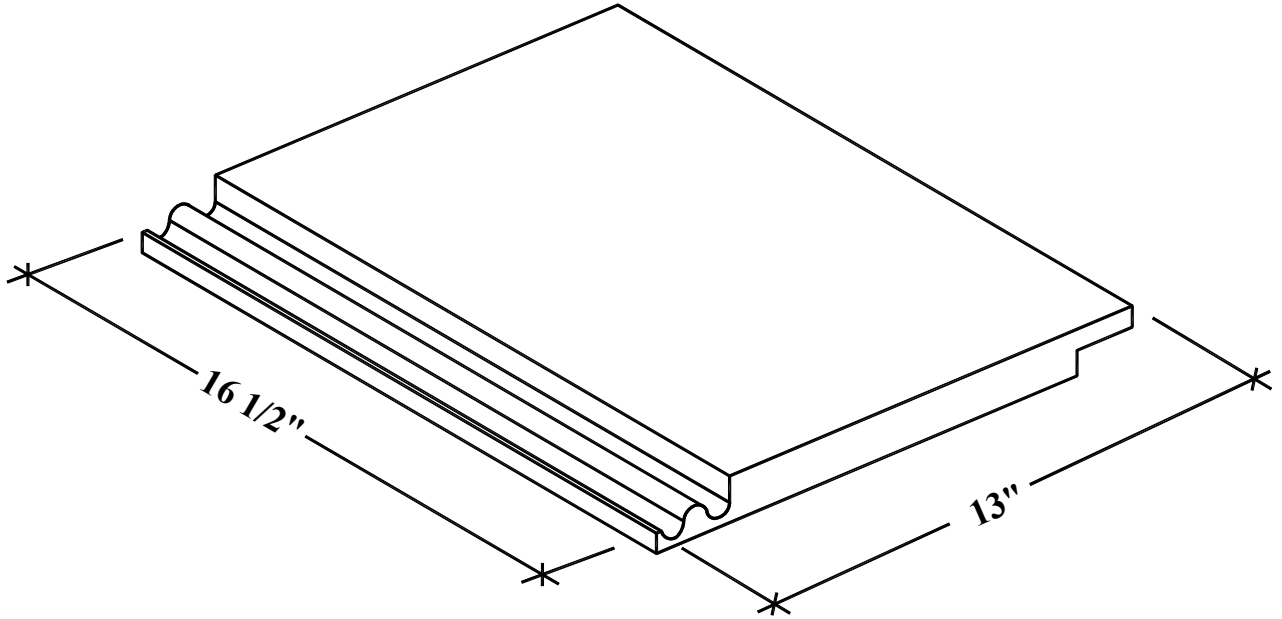

END OF THIS ACCEPTANCE



NOA No.: 22-0331.15
Expiration Date: 12/08/25
Approval Date: 08/11/22
Page 7 of 7