



DEPARTMENT OF REGULATORY AND ECONOMIC RESOURCES (RER)  
BOARD AND CODE ADMINISTRATION DIVISION

MIAMI-DADE COUNTY  
PRODUCT CONTROL SECTION  
11805 SW 26 Street, Room 208  
Miami, Florida 33175-2474  
T (786) 315-2590 F (786) 315-2599  
[www.miamidade.gov/economy](http://www.miamidade.gov/economy)

## NOTICE OF ACCEPTANCE (NOA)

Westlake Royal Roofing, LLC  
7575 Irvine Center Drive, Suite 100  
Irvine, CA 92618

### SCOPE:

This NOA is being issued under the applicable rules and regulations governing the use of construction materials. The documentation submitted has been reviewed and accepted by Miami-Dade County RER - Product Control Section to be used in Miami-Dade County and other areas where allowed by the Authority Having Jurisdiction (AHJ).

This NOA shall not be valid after the expiration date stated below. The Miami-Dade County Product Control Section (in Miami-Dade County) and/or the AHJ (in areas other than Miami-Dade County) reserve the right to have this product or material tested for quality assurance purposes. If this product or material fails to perform in the accepted manner, the manufacturer will incur the expense of such testing and the AHJ may immediately revoke, modify, or suspend the use of such product or material within their jurisdiction. RER reserves the right to revoke this acceptance, if it is determined by Miami-Dade County Product Control Section that this product or material fails to meet the requirements of the applicable building code.

This product is approved as described herein, and has been designed to comply with the Florida Building Code including the High Velocity Hurricane Zone of the Florida Building Code.

### DESCRIPTION: Saxony 900 Concrete Roof Tile

**LABELING:** Each unit shall bear a permanent label with the manufacturer's name or logo, city, state and following statement: "Miami-Dade County Product Control Approved", unless otherwise noted herein.

**RENEWAL** of this NOA shall be considered after a renewal application has been filed and there has been no change in the applicable building code negatively affecting the performance of this product.

**TERMINATION** of this NOA will occur after the expiration date or if there has been a revision or change in the materials, use, and/or manufacture of the product or process. Misuse of this NOA as an endorsement of any product, for sales, advertising or any other purposes shall automatically terminate this NOA. Failure to comply with any section of this NOA shall be cause for termination and removal of NOA.

**ADVERTISEMENT:** The NOA number preceded by the words Miami-Dade County, Florida, and followed by the expiration date may be displayed in advertising literature. If any portion of the NOA is displayed, then it shall be done in its entirety.

**INSPECTION:** A copy of this entire NOA shall be provided to the user by the manufacturer or its distributors and shall be available for inspection at the job site at the request of the Building Official.

This NOA revises NOA# 22-0714.17 and consists of pages 1 through 11.  
The submitted documentation was reviewed by Alex Tigera.

01/04/24



NOA No.: 22-1118.07  
Expiration Date: 04/26/27  
Approval Date: 01/04/24  
Page 1 of 11

## ROOFING ASSEMBLY APPROVAL

**Category:** Roofing  
**Sub-Category:** Roofing Tiles  
**Material:** Concrete  
**Deck Type:** Wood

### 1. SCOPE

This NOA approves a system using **Saxony 900 (Slate, Shake & Split Shake) Concrete Roof Tile**, as manufactured Westlake Royal Roofing LLC in Lake Wales, FL and described this Notice of Acceptance. For locations where the pressure requirements, as determined by applicable Building Code, do not exceed the design pressure values obtained by calculations in compliance with RAS 127 using the values listed in the installation section herein. The attachment calculations shall be done as a moment based system.

### 2. PRODUCT DESCRIPTION

<u>Manufactured by Applicant</u>	<u>Dimensions</u>	<u>Test Specifications</u>	<u>Product Description</u>
Saxony 900-Slate	Length = 17" Width = 13" thickness = 1-5/32"	TAS 112	Flat/Low profile, interlocking, high-pressure extruded concrete roof tile with two nail holes. For direct deck, batten, mortar set or adhesive set applications.
Saxony 900 - Split Shake	Length = 17" Width = 13" thickness = 1-9/32"	TAS 112	Flat/Low profile, interlocking, high-pressure extruded concrete roof tile with two nail holes. For direct deck, batten, mortar set or adhesive set applications. Top surface produced with 4 different configurations: <ol style="list-style-type: none"><li>1. Complete tile brushed</li><li>2. Right half brushed (shown in drawing)</li><li>3. Left half brushed</li><li>4. No brush</li></ol>
Saxony 900-Shake	Length = 17" Width = 13" thickness = 1-9/32"	TAS 112	Flat/Low profile, interlocking, high-pressure extruded concrete roof tile with two nail holes. For direct deck, batten, mortar set or adhesive set applications.
Trim Pieces	Length: varies Width: varies varying thickness	TAS-112	Accessory trim, boosted Barcelona, concrete roof pieces for use at hips, ridges and rakes.



## 2.1 PRODUCTS MANUFACTURED BY OTHERS

<u>Product Name</u>	<u>Product Description</u>	<u>Manufacturer (With Current NOA)</u>
Polyset® AH-160	Two component polyurethane foam adhesive.	ICP Construction Inc.
APOC® Polyset® RTA-1	Single component polyurethane foam roof tile adhesive.	ICP Construction Inc.
TILE BOND™ Roof Tile Adhesive	Single component polyurethane foam roof tile adhesive.	DuPont de Nemours, Inc.
“Tile Tite” Roof Tile Mortar	Premixed, pre-bagged roof tile mortar.	Bermuda Roof Co. Inc.
Touch ‘N Seal StormBond® 2 Two-Component Polyurethane Roof Tile Adhesive	Two component polyurethane foam adhesive.	DAP Foam, Inc.
Touch ‘N Seal StormBond® One Component Polyurethane Roof Tile Adhesive	One component polyurethane foam adhesive.	DAP Foam, Inc.

## 2.2 MANUFACTURING LOCATION

### 2.2.1. Lake Wales, FL

## 2.3 EVIDENCE SUBMITTED:

<u>Test Agency</u>	<u>Test Identifier</u>	<u>Test Name/Report</u>	<u>Date</u>
The Center for Applied Engineering, Inc.	94-084	Static Uplift Testing TAS 101 (Mortar Set)	May 1994
	94-060A	Static Uplift Testing TAS 101 (Adhesive Set)	March, 1994
	25-7183-6	Static Uplift Testing TAS 102 (2 Quik-Drive Screws, Direct Deck)	Feb. 1995
	25-7183-5	Static Uplift Testing TAS 102 (2 Quik-Drive Screws, Battens)	Feb. 1995
	25-7214-1	Static Uplift Testing TAS 102 (1 Quik-Drive Screw, Direct Deck)	March, 1995
	25-7214-5	Static Uplift Testing TAS 102 (1 Quik-Drive Screw, Battens)	March, 1995
	Project No. 307025 Test #MDC-77	Wind Driven Rain TAS 100	Oct. 1994
Redland Technologies	7161-03	Wind Tunnel Testing TAS 108 (Nail-On)	Dec. 1991
	Appendix II & III Letter Dated Aug. 1, 1994	Wind Tunnel Testing TAS 108 (Nail-On)	Aug. 1994



	P0631-01	Wind Tunnel Testing TAS 108 (Mortar Set)	July 1994
	P0402	Withdrawal Resistance Testing of screw vs. smooth shank nails	Sept. 1993
Atlanta Testing & Engineering, Inc.	R1.894/R2.894/R3.894	Physical Properties TAS 112	Aug. 1994
Celotex Corporation Testing Service	520109-1	Static Uplift Testing TAS 101	Dec. 1998
	520111-4	Static Uplift Testing TAS 101	March 1999
	520191-1		
Walker Engineering, Inc.	Evaluation Calculations	25-7094	February 1996
	Evaluation Calculations	25-7496	April 1996
	Evaluation Calculations	25-7584/25-7804b-8/25-7804-4 & 5 25-7848-6	December 1996
	Evaluation Calculations	25-7183	March 1995
	Evaluation Calculations Calculations	Aerodynamic Multipliers Two Patty Adhesive Set System	09/01/16 April 1999
	Evaluation Calculations	Restoring Moments Due to Gravity	09/01/16
American Test Lab of South Florida	RT0617.04-16	TAS 112	06/29/16
	RT0209.01-22	TAS 112	02/01/22
	RT0209.04-22	TAS 112	02/17/22
PRI Construction Material Technologies	COPO-002-02-12	TAS 101	10/12/2016
	COPO-002-02-06	TAS 101	10/12/2016
	COPO-002-02-05	TAS 101	10/12/2016
	BORR-022-02-01	TAS 101	02/25/2019
	BORR-022-02-02	TAS 101	02/25/2019
	BORR-022-02-03	TAS 101	02/25/2019
	BORR-022-02-04	TAS 101	02/28/2019
2002T0003.03	TAS 101	11/06/20	
NEMO ETC, LLC	4c-DPBS-20-LSOTM-1.C.R1	TAS 101	12/17/20
	4c-ICP-21-LSOTM-01.A	TAS 101	01/26/22



### 3. LIMITATIONS:

- 3.1 Fire classification is not part of this acceptance.
- 3.2 For mortar or adhesive set tile applications, a static field uplift test shall be performed in accordance with TAS 106.
- 3.3 Applicant shall retain the services of a Miami-Dade County Certified Laboratory to perform quarterly test in accordance with TAS 112, appendix 'A'. Such testing shall be submitted to the Building Code Compliance Office for review.
- 3.4 Minimum underlayment shall be in compliance with the applicable Roofing Applications Standards listed section 4.1 herein.
- 3.5 30/90 hot mopped underlayment applications may be installed perpendicular to the roof slope unless stated otherwise by the underlayment material manufacturers published literature.
- 3.6 This acceptance is for wood deck applications. Minimum deck requirements shall be in compliance with applicable building code.

### 4. INSTALLATION

- 4.1 Saxony 900 (Slate, Shake & Split Shake) Concrete Roof Tile and its components shall be installed in strict compliance with Roofing Application Standard RAS 118, RAS 119, and RAS 120.
- 4.2 Data For Attachment Calculations

Table 1: Average Weight (W) and Dimensions (l x w )			
Tile Profile	Weight-W (lbf)	Length-l (ft)	Width-w (ft)
Saxony 900 Slate, Shake & Split Shake	10.9	1.417	1.08

Table 2: Aerodynamic Multipliers - $\lambda$ (ft <sup>3</sup> )		
Tile Profile	$\lambda$ (ft <sup>3</sup> ) Batten Application	$\lambda$ (ft <sup>3</sup> ) Direct Deck Application
Saxony 900 Slate, Shake & Split Shake	0.291	0.315

Table 3: Restoring Moments due to Gravity - $M_g$ (ft-lbf)												
Tile Profile	2":12"		3":12"		4":12"		5":12"		6":12"		7":12" or greater	
	Direct Deck	Direct Deck	Battens	Direct Deck	Battens	Direct Deck	Battens	Direct Deck	Battens	Direct Deck	Battens	Direct Deck
Saxony 900 Slate &, Shake & Split Shake	7.70	7.62	6.61	7.50	6.48	7.34	6.31	7.16	6.13	6.95		



**Table 4: Attachment Resistance Expressed as a Moment - M<sub>r</sub> (ft-lbf)  
for Mechanically Fastened Systems**

Tile Profile	Fastener Type	Direct Deck (min 15/32" plywood)	Direct Deck (min. 19/32" plywood)	Battens
Saxony 900 Slate, Shake & Split Shake	2-10d Ring Shank Nails	30.9	38.1	17.2
	1-10d Smooth or Screw Shank Nail	7.3	9.8	4.9
	2-10d Smooth or Screw Shank Nails	14.0	18.8	7.4
	1 #8 Screw	30.8	30.8	18.2
	2 #8 Screw	51.7	51.7	24.4
	1-10d Smooth or Screw Shank Nail (Field Clip)	24.3	24.3	24.2
	1-10d Smooth or Screw Shank Nail (Eave Clip)	19.0	19.0	22.1
	2-10d Smooth or Screw Shank Nails (Field Clip)	35.5	35.5	34.8
	2-10d Smooth or Screw Shank Nails (Eave Clip)	31.9	31.9	32.2

**Table 5: Attachment Resistance Expressed as a Moment M<sub>r</sub> (ft-lbf)  
for Two Paddy Adhesive<sup>1</sup> Set Systems**

Tile Profile	Tile Application	Minimum Attachment Resistance
Saxony 900 Slate &, Shake & Split Shake	TILE BOND™ Roof Tile Adhesive	63 <sup>2</sup>
	TILE BOND™ Roof Tile Adhesive	65 <sup>3</sup>
	Polyset® AH-160	31.3 <sup>4</sup>
	APOC® Polyset® RTA-1	38.3 <sup>5</sup>
	Touch 'N Seal StormBond® 2	59 <sup>6</sup>
	Touch 'N Seal StormBond® (one component)	105 <sup>7</sup>

- 1 See foam adhesive manufacturer's component approval for installation requirements.
- 2 Medium paddy weight of 8 grams per paddy of TILE BOND™ Roof Tile Adhesive
- 3 Medium paddy weight of 16 grams per paddy of TILE BOND™ Roof Tile Adhesive
- 4 Medium paddy weight of 8 grams per paddy of Polyset® AH-160
- 5 Medium paddy weight of 11 grams per paddy of APOC® Polyset® RTA-1
- 6 Medium paddy weight of 8 grams per paddy of Touch 'N Seal StormBond® 2
- 7 Medium paddy weight of 18.7 grams between tile and underlayment, paddy weight of 10.5 grams on overlap of tile of Touch 'N Seal StormBond® (one component)



**Table 6: Attachment Resistance Expressed as a Moment -  $M_r$  (ft.-lbf)  
for Single Paddy Adhesive<sup>1</sup> Set Systems**

Tile Profile	Tile Application	Minimum Attachment Resistance
Saxony 900 Slate &, Shake & Split Shake	Polyset® AH-160	119 <sup>8</sup>
	Polyset® AH-160	115 <sup>9</sup>
	Polyset® AH-160	83 <sup>10</sup>
	Polyset® AH-160	60 <sup>11</sup>
	Touch 'N Seal StormBond® 2	93 <sup>12</sup>
	Touch 'N Seal StormBond® 2	62 <sup>13</sup>

- 8 Large paddy weight of 45 grams of Polyset® AH-160  
 9 Medium paddy weight of 34 grams of Polyset® AH-160  
 10 Medium paddy weight of 24 grams of Polyset® AH-160  
 11 Medium paddy weight of 18 grams of Polyset® AH-160  
 12 Large paddy weight of 45 grams of Touch 'N Seal StormBond® 2  
 13 Medium paddy weight of 24 grams of Touch 'N Seal StormBond® 2

**Table 7: Attachment Resistance Expressed as a Moment -  $M_r$  (ft.-lbf)  
for Mortar Set Systems**

Tile Profile	Tile Application	Attachment Resistance
Saxony 900 Slate &, Shake & Split Shake	Mortar Set <sup>14</sup>	43.9

- 14 Bermuda Roof Co. Inc. Tile-Tite Roof Tile Mortar.

**Table 8: Attachment Resistance Expressed as a Moment  $M_f$  (ft.-lbf)  
for Hybrid Attachment**

Tile Profile	Tile Application	Minimum Attachment Resistance
Saxony 900 Slate &, Shake & Split Shake	Two (2) #8 Screws and ICP Construction Inc.'s APOC® Polyset® RTA-1	39.4 <sup>15</sup>

- 15 Medium paddy weight of 11 grams per paddy of APOC® Polyset® RTA-1 at headlap.



**5. LABELING**

5.1 All tiles shall bear the imprint or identifiable marking of the manufacturer's name or logo as detailed below, or following statement: "Miami-Dade County Product Control Approved".



**OR**

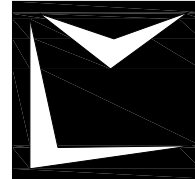

**LABEL FOR SAXONY 900 TILES (LAKE WALES FL PLANT)  
LOCATED UNDERNEATH TILE**

**6. BUILDING PERMIT REQUIREMENTS**

6.1 Application for building permit shall be accompanied by copies of the following:

6.1.1 This Notice of Acceptance.

6.1.2 Any other documents required by the Building Official or applicable building code in order to properly evaluate the installation of this system.



**NOA No.: 22-1118.07  
Expiration Date: 04/26/27  
Approval Date: 01/04/24  
Page 8 of 11**



# PROFILE DRAWINGS

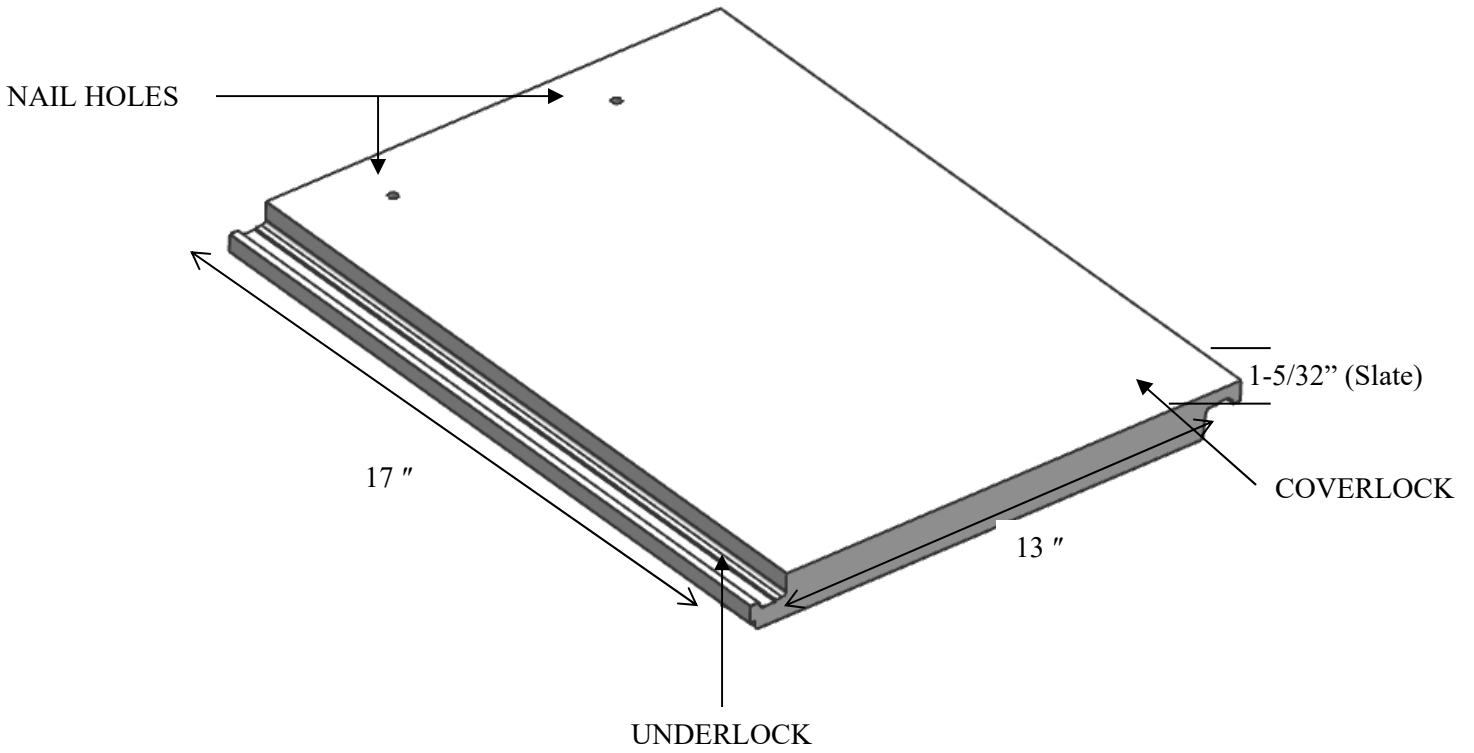

**SAXONY 900 - SLATE**



## PROFILE DRAWINGS

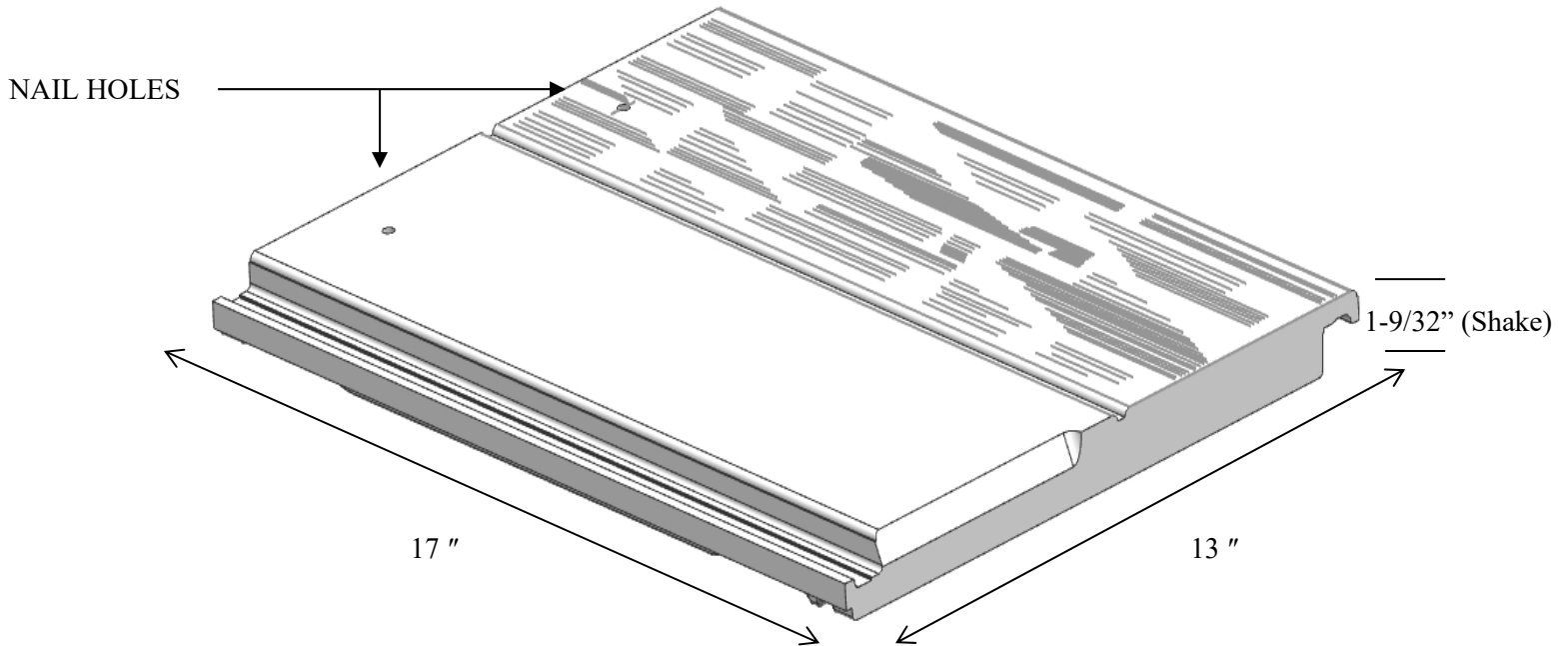

**Note: Available Top Surface Finishes**

1. Complete tile brushed
2. Right half brushed (shown in drawing)
3. Left half brushed
4. No brush

### SAXONY 900 - SPLIT SHAKE



**PROFILE DRAWINGS**

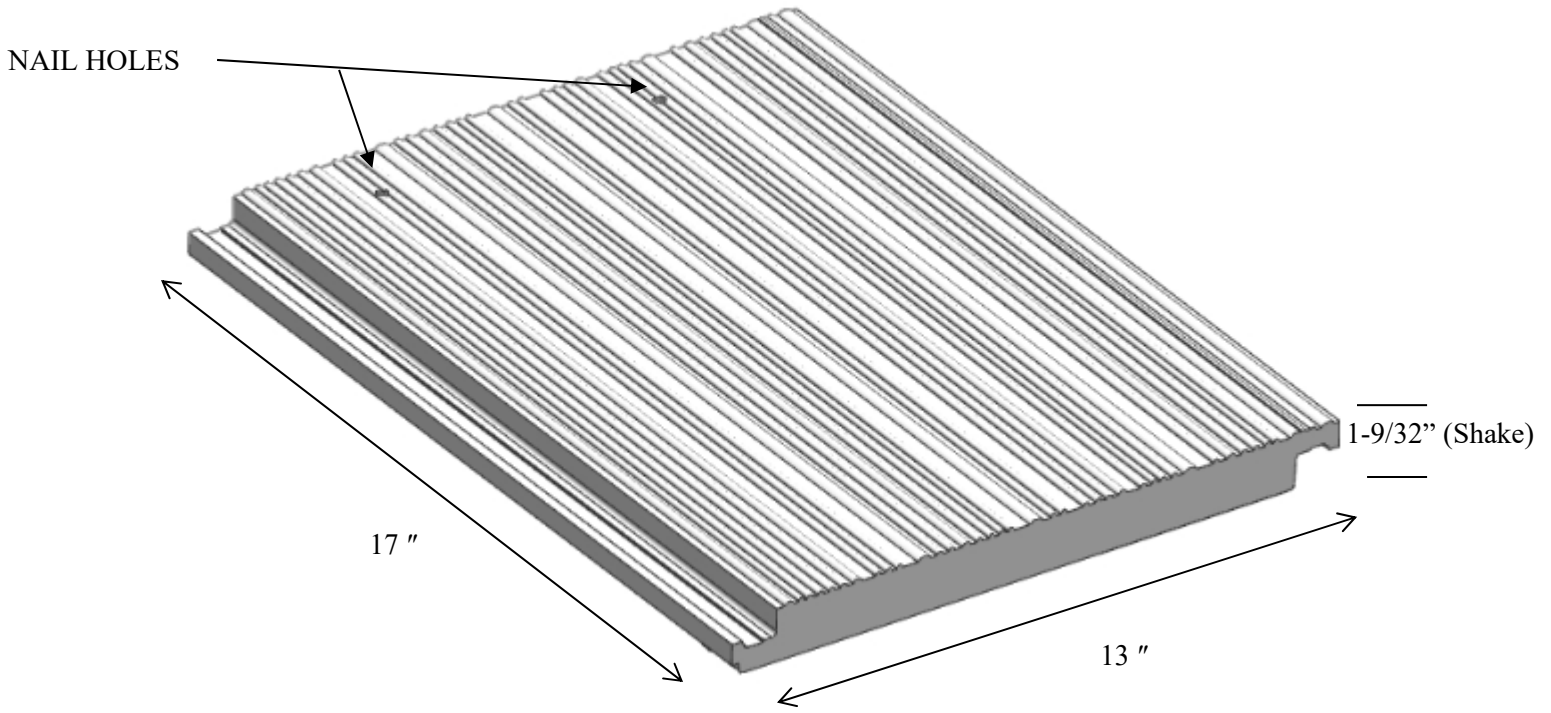

**SAXONY 900- SHAKE**

**END OF THIS ACCEPTANCE**

