



DEPARTMENT OF REGULATORY AND ECONOMIC RESOURCES (RER)
BOARD AND CODE ADMINISTRATION DIVISION

MIAMI-DADE COUNTY
PRODUCT CONTROL SECTION
11805 SW 26 Street, Room 208
Miami, Florida 33175-2474
T (786) 315-2590 F (786) 315-2599
www.miamidade.gov/economy

NOTICE OF ACCEPTANCE (NOA)

Westlake Royal Roofing LLC
7575 Irvine Center Drive, Suite 100
Irvine, CA 92618

SCOPE:

This NOA is being issued under the applicable rules and regulations governing the use of construction materials. The documentation submitted has been reviewed and accepted by Miami-Dade County RER - Product Control Section to be used in Miami-Dade County and other areas where allowed by the Authority Having Jurisdiction (AHJ).

This NOA shall not be valid after the expiration date stated below. The Miami-Dade County Product Control Section (in Miami-Dade County) and/or the AHJ (in areas other than Miami-Dade County) reserve the right to have this product or material tested for quality assurance purposes. If this product or material fails to perform in the accepted manner, the manufacturer will incur the expense of such testing and the AHJ may immediately revoke, modify, or suspend the use of such product or material within their jurisdiction. RER reserves the right to revoke this acceptance, if it is determined by Miami-Dade County Product Control Section that this product or material fails to meet the requirements of the applicable building code.

This product is approved as described herein, and has been designed to comply with the Florida Building Code including the High Velocity Hurricane Zone of the Florida Building Code.

DESCRIPTION: Barcelona 900 Concrete Roof Tile

LABELING: Each unit shall bear a permanent label with the manufacturer's name or logo, city, state and following statement: "Miami-Dade County Product Control Approved", unless otherwise noted herein.

RENEWAL of this NOA shall be considered after a renewal application has been filed and there has been no change in the applicable building code negatively affecting the performance of this product.

TERMINATION of this NOA will occur after the expiration date or if there has been a revision or change in the materials, use, and/or manufacture of the product or process. Misuse of this NOA as an endorsement of any product, for sales, advertising or any other purposes shall automatically terminate this NOA. Failure to comply with any section of this NOA shall be cause for termination and removal of NOA.

ADVERTISEMENT: The NOA number preceded by the words Miami-Dade County, Florida, and followed by the expiration date may be displayed in advertising literature. If any portion of the NOA is displayed, then it shall be done in its entirety.

INSPECTION: A copy of this entire NOA shall be provided to the user by the manufacturer or its distributors and shall be available for inspection at the job site at the request of the Building Official.

This NOA revises NOA# 22-0714.18 and consists of pages 1 through 8.
The submitted documentation was reviewed by Alex Tigera.

01/22/24



NOA No.: 22-1118.08
Expiration Date: 04/26/27
Approval Date: 01/04/24
Page 1 of 8

ROOFING ASSEMBLY APPROVAL

Category: Roofing
Sub-Category: Roofing Tiles
Material: Concrete

1. SCOPE

This renews a system using **Barcelona 900 Concrete Roof Tile**, as manufactured Westlake Royal Roofing LLC in Lake Wales, FL and described in Section 2 of this Notice of Acceptance. For locations where the pressure requirements, as determined by applicable Building Code, do not exceed the design pressure values obtained by calculations in compliance with RAS 127 using the values listed in section 4 herein. The attachment calculations shall be done as a moment based system.

2. PRODUCT DESCRIPTION

<u>Manufactured by Applicant</u>	<u>Dimensions</u>	<u>Test Specifications</u>	<u>Product Description</u>
Barcelona 900	Length = 17" Width = 13" ½" thick	TAS 112 Type – 1a	High profile, interlocking, one-piece, 'S' shaped, high-pressure extruded concrete roof tile equipped with three nail holes. For direct deck or battened nail-on, mechanically fastened, mortar set or adhesive set applications.
Trim Pieces	Length: varies Width: varies varying thickness	TAS-112	Accessory trim, boosted Barcelona, concrete roof pieces for use at hips, rakes, ridges and valley terminations manufactured for each tile profile.

2.1 PRODUCTS MANUFACTURED BY OTHERS

<u>Product Name</u>	<u>Product Description</u>	<u>Manufacturer (With Current NOA)</u>
Polyset® AH-160	Two component polyurethane foam adhesive.	ICP Construction Inc.
APOC® Polyset® RTA-1	Single component polyurethane foam roof tile adhesive.	ICP Construction Inc.
TILE BOND™ Roof Tile Adhesive	Single component polyurethane foam roof tile adhesive.	DuPont de Nemours, Inc.
Touch 'N Seal StormBond® 2 Two-Component Polyurethane Roof Tile Adhesive	Two component polyurethane foam adhesive.	DAP Foam, Inc.
Touch 'N Seal StormBond® One Component Polyurethane Roof Tile Adhesive	One component polyurethane foam adhesive.	DAP Foam, Inc.



NOA No.: 22-1118.08
 Expiration Date: 04/26/27
 Approval Date: 01/04/24
 Page 2 of 8

2.2 MANUFACTURING LOCATION

2.2.1. Lake Wales, FL

2.3 SUBMITTED EVIDENCE:

<u>Test Agency</u>	<u>Test Identifier</u>	<u>Test Name/Report</u>	<u>Date</u>
Redland Technologies	7161-03	Static Uplift Testing	Dec. 1991
	Appendix III	TAS 102 & TAS 102(A)	
	7161-03	Wind Tunnel Testing	Dec. 1991
	Appendix II	TAS 108(Nail-On)	
	P0402	Withdrawal Resistance	Sept. 1993
		Testing of screw vs. smooth shank nails	
	Letter Dated Aug. 1, 1994	Wind Tunnel Testing	Aug. 1994
	P0631-01	TAS 108 (Nail-On)	
		Wind Tunnel Testing	July 1994
		TAS 108 (Mortar Set)	
Professional Service Industries, Inc.	IC-1320-94	Physical Properties	Feb. 1995
		TAS 112	
The Center for Applied Engineering, Inc.	25-7688-3	TAS 101 (Adhesive Set)	June 1996
	25-7688-10	TAS 101 (Mortar Set)	July 1996
	25-7688-5	Static Uplift Testing	June 1996
		TAS 102	
		(3" Headlap, Nails, Direct Deck, New Construction)	
	25-7688-4	Static Uplift Testing	June 1996
		TAS 102	
		(4" Headlap, Nails, Clips)	
Celotex Corporation Testing Services	520111-3	Static Uplift Testing	Dec. 1998
	520191-2-1	TAS 101	March 1999
Walker Engineering, Inc.	Calculations	Aerodynamic Multiplier	09/01/16
	Evaluation Calculations	Restoring Moments Due to Gravity	09/01/16
American Test Lab of South Florida	RT0617.03-16	TAS 112	06/29/16
	RT0209.05-22	TAS 112	02/17/22
PRI Construction Materials Technologies	COPO-002-02-10	TAS 101	10/12/2016
	COPO-002-02-02	TAS 101	10/12/2016
	COPO-002-02-01	TAS 101	10/12/2016
	2002T0003.01	TAS 101	11/06/20
NEMO ETC, LLC	4c-DPBS-20-LSOTM-01.C.R1	TAS 101	12/17/20
	4c-ICP-21-LSOTM-01.A	TAS 101	01/26/22



3. LIMITATIONS:

- 3.1 Fire classification is not part of this acceptance.
- 3.2 For mortar or adhesive set tile applications, a static field uplift test in accordance with TAS 106 may require, refer to applicable building code.
- 3.3 Applicant shall retain the services of a Miami-Dade County Certified Laboratory to perform quarterly test in accordance with TAS 112, appendix 'A'. Such testing shall be submitted to the Department of Regulatory and Economic Development – Product Control Section for review.
- 3.4 Minimum underlayment shall be in compliance with the applicable Roofing Applications Standards listed section 4.1 herein.
- 3.5 Minimum slope 4/12 for mechanically attached tiles.
- 3.6 30/90 hot mopped underlayment applications may be installed perpendicular to the roof slope unless stated otherwise by the underlayment material manufacturers published literature.
- 3.7 This acceptance is for wood deck applications. Minimum deck requirements shall be in compliance with applicable building code.

4. INSTALLATION

- 4.1 Barcelona 900 Concrete Roof Tile and its components shall be installed in strict compliance with Roofing Application Standard RAS 118, RAS 119, and RAS 120.
- 4.2 Data For Attachment Calculations

Table 1: Average Weight (W) and Dimensions (l x w)			
Tile Profile	Weight-W (lbf)	Length-l (ft.)	Width-w (ft.)
Barcelona 900	11.5	1.417	1.08

Table 2: Aerodynamic Multipliers - λ (ft ³)		
Tile Profile	λ (ft ³) Batten Application	λ (ft ³) Direct Deck Application
Barcelona 900	0.286	0.301

Table 3: Restoring Moments due to Gravity - M _g (ft.-lbf)												
Tile Profile	2":12"		3":12"		4":12"		5":12"		6":12"		7":12" or greater	
	Battens	Direct Deck	Battens	Direct Deck	Battens	Direct Deck	Battens	Direct Deck	Battens	Direct Deck	Battens	Direct Deck
Barcelona 900	N/A	7.07	N/A	7.00	6.19	6.90	6.06	6.76	5.92	6.60	5.76	6.42



**Table 4: Attachment Resistance Expressed as a Moment - M_r (ft.-lbf)
for Mechanically Attached Systems**

Tile Profile	Fastener Type	Direct Deck (min 15/32" plywood)	Direct Deck (min. 19/32" plywood)	Battens
Barcelona 900	2-10d Ring Shank Nails	28.6	41.2	19.4
	1-10d Smooth or Screw Shank Nail	5.1	6.8	2.8
	2-10d Smooth or Screw Shank Nails	6.9	9.2	7.3
	1 #8 Screw	20.7	20.7	18.1
	2 #8 Screw	43.2	43.2	29.8
	1-10d Smooth or Screw Shank Nail (Field Clip)	23.1	23.1	19.0
	1-10d Smooth or Screw Shank Nail (Eave Clip)	29.3	29.3	24.0
	2-10d Smooth or Screw Shank Nails (Field Clip)	27.6	27.6	38.6
	2-10d Smooth or Screw Shank Nails (Eave Clip)	38.1	38.1	41.8
	2-10d Ring Shank Nails ¹	33.1	48.1	45.2

1. Installation with a 4" tile headlap and fasteners are located a min. of 2½" from head of tile.

**Table 5: Attachment Resistance Expressed as a Moment M_r (ft.-lbf)
for Two Paddy Adhesive² Set Systems**

Tile Profile	Tile Application	Minimum Attachment Resistance
Barcelona 900	TILE BOND™ Roof Tile Adhesive	19 ³
	TILE BOND™ Roof Tile Adhesive	29.3 ⁴
	Polyset® AH-160	29.3 ⁵
	Touch 'N Seal StormBond® 2	66 ⁶
	Touch 'N Seal StormBond®	48 ⁷

2 See foam adhesive manufacturer's component approval for installation requirements.

3 Medium paddy weight of 8 grams per paddy of TILE BOND™ Roof Tile Adhesive

4 Medium paddy weight of 10.7 grams per paddy of TILE BOND™ Roof Tile Adhesive

5 Medium paddy weight of 8 grams per paddy of Polyset® AH-160

6 Medium paddy weight of 8 grams per paddy of Touch 'N Seal StormBond® 2

7 Medium paddy weight of 8 grams between tile and underlayment, paddy weight of 4 grams on overlap of tile of Touch 'N Seal StormBond® (one component)



**Table 6: Attachment Resistance Expressed as a Moment - M_r (ft.-lbf)
for Single Paddy Adhesive² Set Systems**

Tile Profile	Tile Application	Minimum Attachment Resistance
Barcelona 900	Polyset® AH-160	66.5 ⁸
	Polyset® AH-160	38.7 ⁹
	Touch 'N Seal StormBond® 2	82 ¹⁰
	Touch 'N Seal StormBond® 2	63 ¹¹
	TILE BOND™ Roof Tile Adhesive	58 ¹²

- 8 Large paddy weight of 63 grams of Polyset® AH-160
 9 Medium paddy weight of 24 grams of Polyset® AH-160
 10 Large paddy weight of 60 grams of Touch 'N Seal StormBond® 2
 11 Medium paddy weight of 30 grams of Touch 'N Seal StormBond® 2
 12 Two paddys combined to form one. Place one 10 gram paddy on the center of the underside of the tile, place a second paddy of 20 grams on the deck. When tile is placed the two paddys combine to create one paddy weight of 30 grams total of TILE BOND™ Roof Tile Adhesive.

**Table 7: Attachment Resistance Expressed as a Moment - M_r (ft.-lbf)
for Mortar Set Systems**

Tile Profile	Tile Application	Attachment Resistance
Barcelona 900	Mortar Set ¹³	24.5

13 See specific mortar manufacturers Notice of Acceptance

**Table 8: Attachment Resistance Expressed as a Moment M_f (ft.-lbf)
for Hybrid Attachment**

Tile Profile	Tile Application	Minimum Attachment Resistance
Barcelona 900	Two (2) #8 Screws and ICP Construction Inc.'s APOC® Polyset® RTA-1	57.1 ¹⁴

14 Medium paddy weight of 11 grams per paddy of APOC® Polyset® RTA-1 at headlap.



5. LABELING

- 5.1 All tiles shall bear the imprint or identifiable marking of the manufacturer's name or logo as detailed below, or following statement: "Miami-Dade County Product Control Approved".

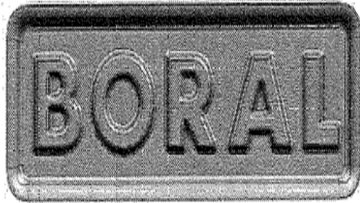

OR

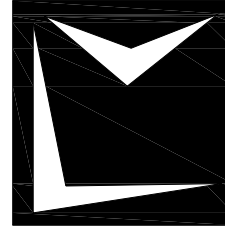

**LABEL FOR BARCELONA 900 TILE (LAKE WALES FL PLANT 2)
LOCATED UNDERNEATH TILE**

6. BUILDING PERMIT REQUIREMENTS

- 6.1 Application for building permit shall be accompanied by copies of the following:
- 6.1.1 This Notice of Acceptance.
 - 6.1.2 Any other documents required by the Building Official or applicable building code in order to properly evaluate the installation of this system.



NOA No.: 22-1118.08
Expiration Date: 04/26/27
Approval Date: 01/04/24
Page 7 of 8

PROFILE DRAWING

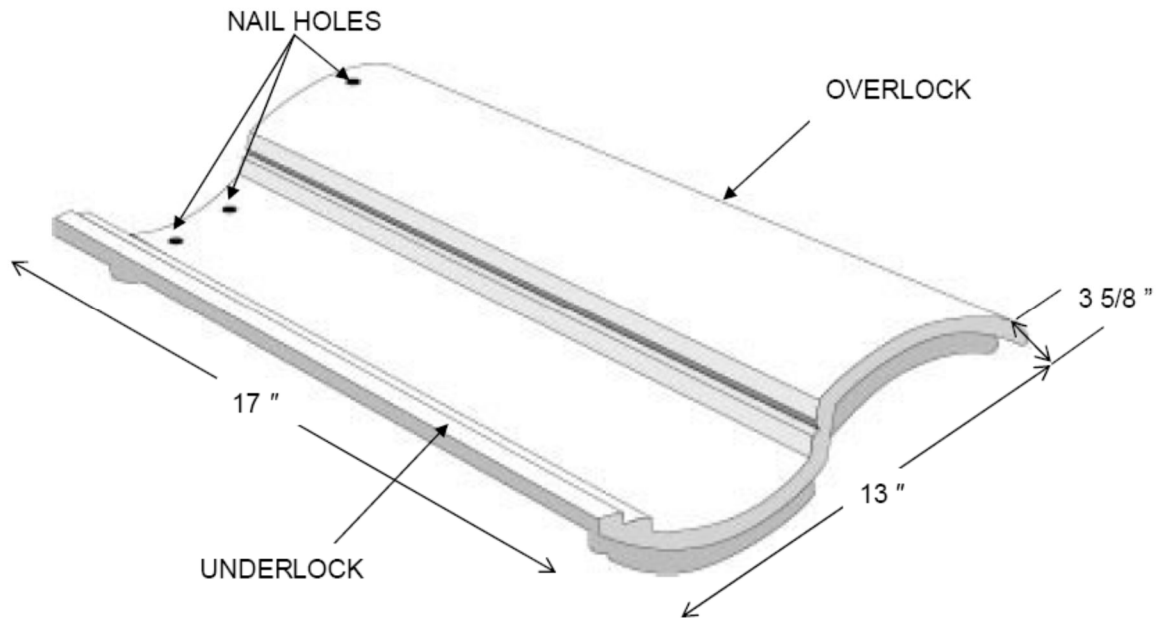

BARCELONA 900 CONCRETE ROOF TILE

END OF THIS ACCEPTANCE



NOA No.: 22-1118.08
Expiration Date: 04/26/27
Approval Date: 01/04/24
Page 8 of 8