



DEPARTMENT OF REGULATORY AND ECONOMIC RESOURCES (RER)
BOARD AND CODE ADMINISTRATION DIVISION

MIAMI-DADE COUNTY
PRODUCT CONTROL SECTION
11805 SW 26 Street, Room 208
Miami, Florida 33175-2474
T (786) 315-2590 F (786) 315-2599
www.miamidade.gov/economy

NOTICE OF ACCEPTANCE (NOA)

CertainTeed LLC
20 Moores Road
Malvern, PA 19355

SCOPE:

This NOA is being issued under the applicable rules and regulations governing the use of construction materials. The documentation submitted has been reviewed and accepted by Miami-Dade County RER - Product Control Section to be used in Miami Dade County and other areas where allowed by the Authority Having Jurisdiction (AHJ).

This NOA shall not be valid after the expiration date stated below. The Miami-Dade County Product Control Section (In Miami Dade County) and/or the AHJ (in areas other than Miami Dade County) reserve the right to have this product or material tested for quality assurance purposes. If this product or material fails to perform in the accepted manner, the manufacturer will incur the expense of such testing and the AHJ may immediately revoke, modify, or suspend the use of such product or material within their jurisdiction. RER reserves the right to revoke this acceptance, if it is determined by Miami-Dade County Product Control Section that this product or material fails to meet the requirements of the applicable building code.

This product is approved as described herein, and has been designed to comply with the Florida Building Code including the High Velocity Hurricane Zone of the Florida Building Code.

DESCRIPTION: CertainTeed Shingle Ridge, Shadow Ridge, and Cedar Crest Hip and Ridge Shingles

LABELING: Each unit shall bear a permanent label with the manufacturer's name or logo, city, state and following statement: "Miami-Dade County Product Control Approved", unless otherwise noted herein.

RENEWAL of this NOA shall be considered after a renewal application has been filed and there has been no change in the applicable building code negatively affecting the performance of this product.

TERMINATION of this NOA will occur after the expiration date or if there has been a revision or change in the materials, use, and/or manufacture of the product or process. Misuse of this NOA as an endorsement of any product, for sales, advertising or any other purposes shall automatically terminate this NOA. Failure to comply with any section of this NOA shall be cause for termination and removal of NOA.

ADVERTISEMENT: The NOA number preceded by the words Miami-Dade County, Florida, and followed by the expiration date may be displayed in advertising literature. If any portion of the NOA is displayed, then it shall be done in its entirety.

INSPECTION: A copy of this entire NOA shall be provided to the user by the manufacturer or its distributors and shall be available for inspection at the job site at the request of the Building Official.

This NOA renews and revises NOA# 22-0901.04 and consists of pages 1 through 7.
The submitted documentation was reviewed by Alex Tigera.



NOA No.: 23-0118.03
Expiration Date: 11/15/28
Approval Date: 10/12/23
Page 1 of 7

ROOFING ASSEMBLY APPROVAL

Category:	Roofing
Sub-Category:	Asphalt Shingles
Materials	Laminated
Deck Type:	Wood

SCOPE

This approves CertainTeed Shangle Ridge, Shadow Ridge, and Cedar Crest Hip and Ridge Shingles as manufactured by CertainTeed LLC and described in Section 2 of this Notice of Acceptance.

PRODUCT DESCRIPTION

<u>Product</u>	<u>Dimensions</u>	<u>Test Specifications</u>	<u>Product Description</u>
Shangle Ridge <i>Manufacturing Location(s) # 1</i>	12" x 18"	TAS 110	A pre-assembled, double layer hip and ridge fiberglass reinforced asphalt shingle with an 8" exposure.
Shadow Ridge <i>Manufacturing Location(s) # 1, 2, 3</i>	12" x 12"	TAS 110	A pre-assembled hip and ridge fiberglass reinforced asphalt shingle with an 5" exposure.
Cedar Crest <i>Manufacturing Location(s) # 1</i>	12" x 12"	TAS 110	A pre-assembled hip and ridge fiberglass reinforced asphalt shingle with an 8" exposure.

PRODUCTS MANUFACTURED BY OTHERS

<u>Product</u>	<u>Product Description</u>	<u>Size</u>	<u>Manufacturer</u>
Any approved sealant with a current Miami Dade NOA	Sealant	various	Any approved manufacturer (with a current Miami Dade NOA)
Any approved adhesive with a current Miami Dade NOA	ASTM C920, Type S, Grade NS, min Class 25	various	Any approved manufacturer (with a current Miami Dade NOA)



MANUFACTURING LOCATION

1. Oxford, NC.
2. Shakopee, MN.
3. Norwood, MA.

EVIDENCE SUBMITTED

<u>Test Agency</u>	<u>Test Identifier</u>	<u>Test Name/Report</u>	<u>Date</u>
PRI Asphalt Technologies, Inc.	CTC-028-02-01	ASTM D 6381	08/06/07
	CTC-021-02-01	TAS 100(A)	05/16/06
	CTC-029-02-01	TAS 100(A)	08/06/07
	CTC-030-02-01	TAS 100(A)	08/06/07
	CTC-020-02-01	TAS 100(A)	05/16/06
	CTC-072-02-01	TAS 100(A)	02/10/11
	CTC-334-02-01	TAS 107	08/29/17
	CTC-330-02-01	TAS 107	08/27/17
	CTC-310-02-01	TAS 100(A)	05/31/17
	CTC-311-02-01	TAS 100(A)	05/31/17
	CTC-312-02-01	TAS 100(A)	05/31/17
	CTC-315-02-01	TAS 100(A)	06/19/17
	CTC-314-02-01	TAS 100(A)	06/19/17
Underwriters Laboratories, Inc.	07CA30825	ASTM D 3161	08/06/07
	R684	ASTM D 3462	08/04/04
	R684	ASTM D 3462	08/05/04
	10CA44960	ASTM D 3462	11/11/10
	10CA44960	ASTM D 3161	11/11/10
	4787855169	ASTM D 3161/3462	07/27/17
	4787855164	ASTM D 3161/3462	06/27/17
	4787867612	ASTM D 3161/3462	07/26/17
	4787855162	ASTM D 3161/3462	06/26/17
	4787855167	ASTM D 3161/3462	06/30/17

LIMITATIONS

1. Fire classification is not part of this acceptance; refer to a current Approved Roofing Materials Directory for fire ratings of this product.
2. Shall not be installed on roof mean heights in excess of 33 ft.
3. All products listed herein shall have a quality assurance audit in accordance with the Florida Building Code and Rule 61G20-3 of the Florida Administrative Code.

INSTALLATION

1. Ridge Cap Shingles shall be installed in compliance with Roofing Application Standard RAS 115.
2. Flashing shall be in accordance with Roofing Application Standard RAS 115
3. The manufacturer shall provide clearly written application instructions.
4. Exposure and course layout shall be in compliance with Layout Details herein

LABELING



NOA No.: 23-0118.03
Expiration Date: 11/15/28
Approval Date: 10/12/23
Page 3 of 7

1. Ridge Cap Shingles shall be labeled with the Miami-Dade Seal as seen below, or the wording "Miami-Dade County Product Control Approved".



BUILDING PERMIT REQUIREMENTS

1. Application for building permit shall be accompanied by copies of the following:
 - 1.1 This Notice of Acceptance.
 - 1.2 Any other documents required by the Building Official or the applicable code in order to properly evaluate the installation of this system.

LAYOUT DETAILS

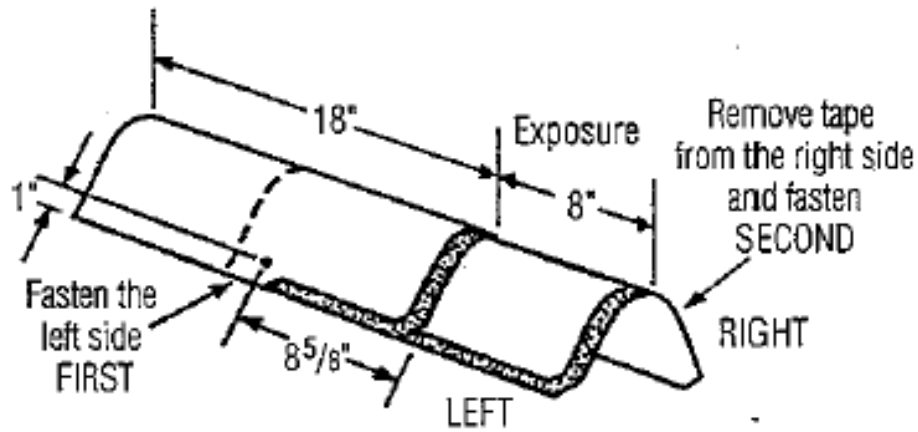

SHANGLE RIDGE



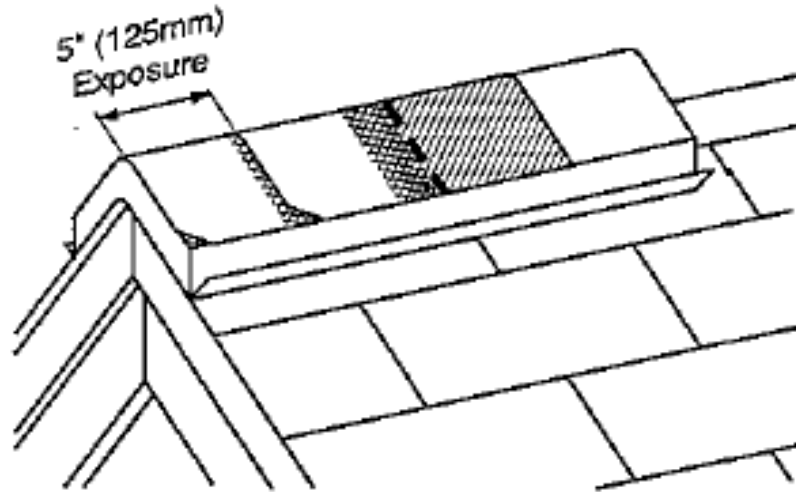

SHADOW RIDGE

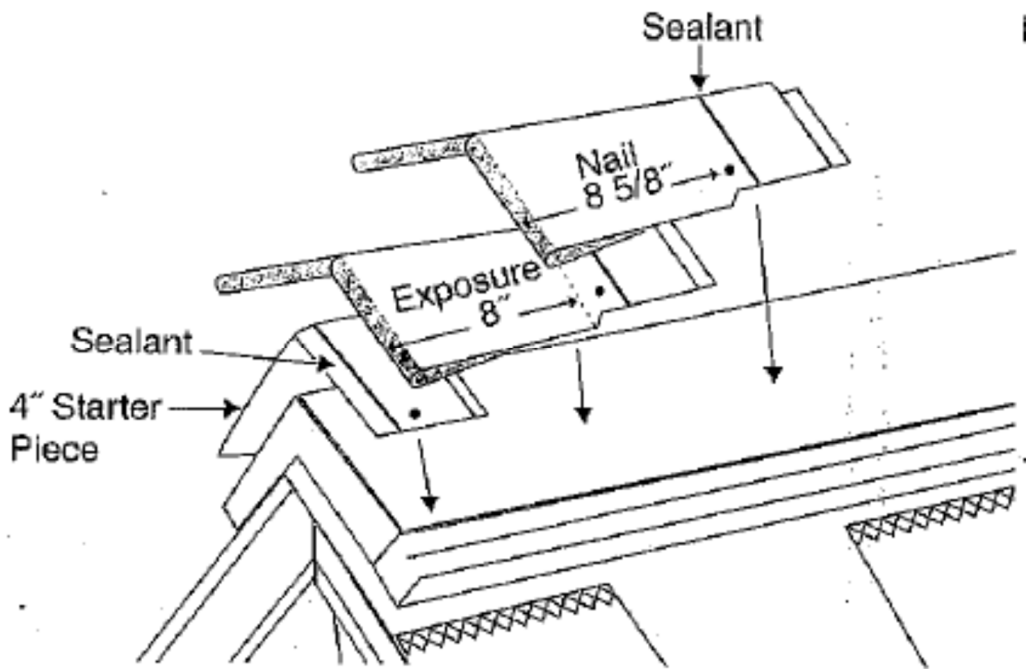

CEDAR CREST

NAILING DETAILS

SHANGLE RIDGE

1/4" wide bead of adhesive, 7" long,
3/4"-1" from side edge of cap shingle

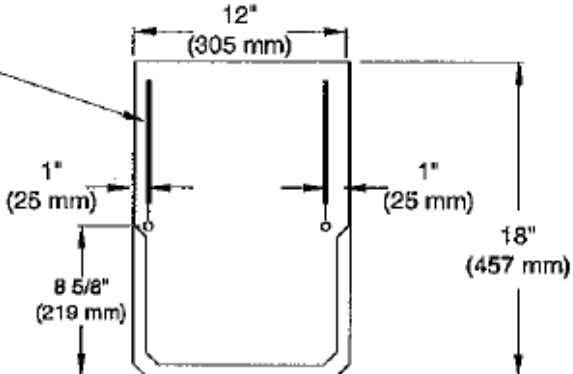

Nailing pattern all applications - two nails per shingle.

SHADOW RIDGE

1/4" wide bead of adhesive, 3"-3 1/2" long,
3/4"-1" from side edge of cap shingle

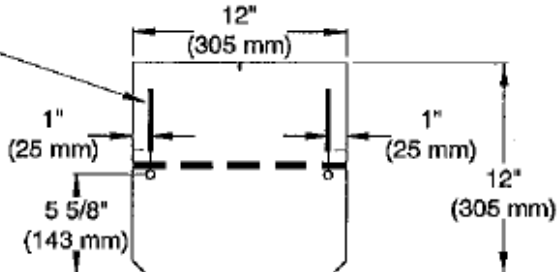

Nailing pattern all applications - two nails per shingle.



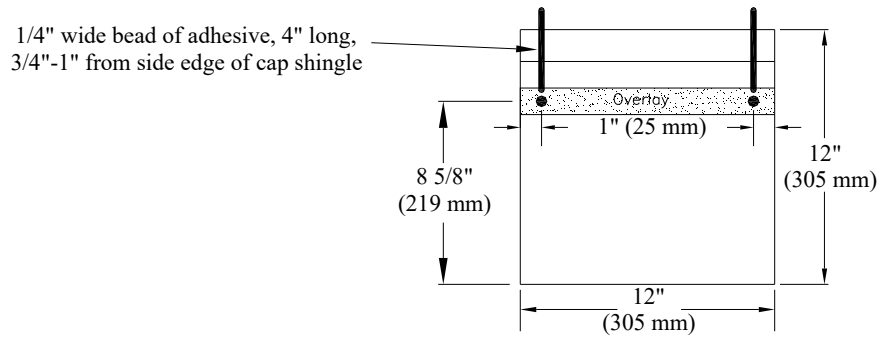

Nailing pattern all applications - two nails per shingle.

CEDAR CREST

END OF THIS ACCEPTANCE

