



DEPARTMENT OF REGULATORY AND ECONOMIC RESOURCES (RER)
BOARD AND CODE ADMINISTRATION DIVISION

MIAMI-DADE COUNTY
PRODUCT CONTROL SECTION
11805 SW 26 Street, Room 208
Miami, Florida 33175-2474
T (786) 315-2590 F (786) 315-2599
www.miamidade.gov/economy

NOTICE OF ACCEPTANCE (NOA)

ArteZanos®, Inc.
9455 SW 78th Street
Miami, FL 33173

SCOPE:

This NOA is being issued under the applicable rules and regulations governing the use of construction materials. The documentation submitted has been reviewed and accepted by Miami-Dade County RER - Product Control Section to be used in Miami Dade County and other areas where allowed by the Authority Having Jurisdiction (AHJ).

This NOA shall not be valid after the expiration date stated below. The Miami-Dade County Product Control Section (In Miami Dade County) and/or the AHJ (in areas other than Miami Dade County) reserve the right to have this product or material tested for quality assurance purposes. If this product or material fails to perform in the accepted manner, the manufacturer will incur the expense of such testing and the AHJ may immediately revoke, modify, or suspend the use of such product or material within their jurisdiction. RER reserves the right to revoke this acceptance, if it is determined by Miami-Dade County Product Control Section that this product or material fails to meet the requirements of the applicable building code.

This product is approved as described herein, and has been designed to comply with the Florida Building Code including the High Velocity Hurricane Zone of the Florida Building Code.

DESCRIPTION: ArteZanos® World Class – Hybrid Systems

LABELING: Each unit shall bear a permanent label with the manufacturer's name or logo, city, state and following statement: "Miami-Dade County Product Control Approved", unless otherwise noted herein.

RENEWAL of this NOA shall be considered after a renewal application has been filed and there has been no change in the applicable building code negatively affecting the performance of this product.

TERMINATION of this NOA will occur after the expiration date or if there has been a revision or change in the materials, use, and/or manufacture of the product or process. Misuse of this NOA as an endorsement of any product, for sales, advertising or any other purposes shall automatically terminate this NOA. Failure to comply with any section of this NOA shall be cause for termination and removal of NOA.

ADVERTISEMENT: The NOA number preceded by the words Miami-Dade County, Florida, and followed by the expiration date may be displayed in advertising literature. If any portion of the NOA is displayed, then it shall be done in its entirety.

INSPECTION: A copy of this entire NOA shall be provided to the user by the manufacturer or its distributors and shall be available for inspection at the job site at the request of the Building Official.

This NOA renews NOA# 20-0908.03 and consists of pages 1 through 33.
The submitted documentation was reviewed by Alex Tigera.



NOA No.: 23-0302.02
Expiration Date: 05/14/28
Approval Date: 05/04/23
Page 1 of 34

ROOFING ASSEMBLY APPROVAL

Category: Roofing
Sub-Category: Hybrid Roofing System
Material: Clay / Steel / Aluminum
Deck Type: Wood

1. SCOPE

This approves a roofing system using **ArteZanos® World Class – Hybrid Systems**, as manufactured by ArteZanos®, Inc. as described in Section 2 of this Notice of Acceptance. For the locations where the pressure requirements, as determined by applicable Building Code, does not exceed the values listed in section 4 herein. The attachment calculations shall be done as a moment based system.

2.1 TRADE NAMES OF PRODUCTS MANUFACTURED OR LABELED BY APPLICANT:

TABLE 1

<u>Manufactured by Applicant</u>	<u>Dimensions</u>	<u>Test Specifications</u>	<u>Product Description</u>
2 Piece Handmade Tapered Mission Barrel Tile <i>Manufacturing Location #1</i>	l = 18" w = 8" ½" thick	ASTM C 1167	High profile, two piece, barrel, clay roof tile for use as the cover in combination with the Aluminum Pans. For adhesive set applications.
2 Piece Rustic Machine Barrel Tile <i>Manufacturing Location #1</i>	l = 17" w = 8.5" ½" thick	ASTM C 1167	High profile, barrel, clay roof tile for use as the cover in combination with the Aluminum Pans. For adhesive set applications.
ArteZanos® Tegole (Italian Flat Tile) <i>Manufacturing Location #1</i>	l = 13.5" w = 9.5" .69" thick	ASTM C 1167	Low profile, two piece, barrel, clay roof tile. For direct deck adhesive or mortar set applications.
Steel Pan <i>Manufacturing Location #2</i>	l = 21"- 84" w = 7.5" – 18" .0179" thick (26 ga.)	TAS 110	Kynar or Hylar coated steel pan tile to be used in conjunction with Handmade Tapered Mission Barrel Tile as the cap. For direct deck adhesive set applications.
Aluminum Pan #1 <i>Manufacturing Location #2</i>	l = 21"-84" w = 7.5 – 18" .025" thick (22 ga.)	TAS 110	Aluminum pan tile (with optional coating of Kynar or Hylar) to be used in conjunction with Handmade Tapered Mission Barrel Tile as the cap. The bent edges each contain one row of perforations. For direct deck adhesive set applications.



<p>Aluminum Pan #2</p> <p><i>Manufacturing Location #2</i></p>	<p>l = 21"-84" w = 8.5" – 18" .025" thick (22 ga.)</p>	<p>TAS 110</p>	<p>Aluminum pan tile (with optional coating of Kynar or Hylar) to be used in conjunction with Handmade Tapered Mission Barrel Tile as the cap. The bent edges each contain two rows of perforations. For direct deck adhesive set applications.</p>
<p>Magnetic Self Sealing Tin Caps</p> <p><i>Manufacturing Location #3</i></p>	<p>Diameter = 1-7/8" .058" thick</p>	<p>TAS 110</p>	<p>A 1-7/8" flexible self-sealing UV resistant magnetic stress plate used with Miami Dade Approved 1-5/8" tin caps.</p>
<p>Trim Pieces</p>	<p>l = varies w = varies varying thickness</p>	<p>ASTM C 1167</p>	<p>Accessory trim, clay roof pieces for use at hips, rakes, ridges and valley terminations.</p>



2.2 TRADE NAMES OF PRODUCTS MANUFACTURED BY OTHERS

TABLE 2

<u>Product Name</u>	<u>Product Description</u>	<u>Manufacturer (With Current NOA)</u>
ICP Adhesives Polyset® AH-160	Two component polyurethane foam adhesive	ICP Adhesives and Sealants, Inc.
Touch ‘n Seal® Storm Bond™ Roof Tile Adhesive	Single component polyurethane foam roof tile adhesive.	DAP Foam, Inc.
REX™ Synfelt	Woven polypropylene coated with a layer of UV stabilized polypropylene on both sides.	Alpha ProTech Engineered Products, Inc.
Sharkskin Ultra®	A multi-layer laminated roof underlayment comprised of a high-strength woven polypropylene core with a UV & antioxidant protection bond layer to both sides and a slip resistant top layer.	Kirsch Building Products, LLC.
Sharkskin Ultra SA®	A multi-layer laminated roof underlayment comprised of a high-strength woven polypropylene core between two layers of UV & antioxidant protection bond and a self-adhering underside and a slip-resistant top layer.	Kirsch Building Products, LLC.
Pex-AL-Pex Tubing, Oxygenated Pex Tubing and Non-Oxygenated Pex Tubing	A coextruded cross-linked polyethylene pressure pipe and/or a coextruded composite pressure pipe with a welded aluminum tube reinforcement between the inner and outer layers.	Various

2.3 MANUFACTURING LOCATION

1. Cucuta, Colombia
2. Miami, FL.
3. Cartagena, Colombia



2.4 EVIDENCE SUBMITTED:

<u>Test Agency</u>	<u>Test Identifier</u>	<u>Test Name/Report</u>	<u>Date</u>
IBA Consultants Inc.	2352-53	TAS 101 (Adhesive Set with Steel Pan)	April 2008
	2352-59	TAS 101 (Adhesive Set with Aluminum Pan#1)	April 2008
Walker Engineering		Thermal Expansion of Steel, Concrete and Clay Components	
Southwest Research Institute	01.13537.01.310	ASTM E-108	April 2008
American Test Lab of South Florida	RT0505.02-09	ASTM C 1167	May 2009
	RT0505.01-09	ASTM C 1167	May 2009
	RT0610.01-13	ASTM C 1167	06/20/13
	RT0610.02-13	ASTM C 1167	06/20/13
	RT1116.01-18	ASTM C 1167	11/28/18
	RT0226.01-14	TAS 101 (Adhesive Set with Aluminum Pan#2)	03/05/14
	RT1023.01-13	TAS 101 (Adhesive Set with Aluminum Pan#2)	12/11/13
	RT1221.01-11	TAS 114 App D	12/23/11
	RT1124.03-18	TAS 101	11/24/18
	RT0104.01-19	TAS 101	01/05/19
	RT0211.01-19	TAS 101	02/04/19
	RT1111.01-15	TAS 101	11/20/15
	RT0715.01-19	TAS 101	07/23/19
	RT1012.01-18	TAS 114 App J	10/17/18
	RT1012.02-18	TAS 114 App J	10/23/18
	RT1205.01-18	TAS 114 App J	02/06/18
	RT0513.01-20	TAS 114 App J	05/27/20
RT0710.01-20	TAS 114 App J	07/13/20	
PRI Construction Materials Technologies	ARTZ-002-02-01	TAS-100	11/24/14
	ARTZ-004-02-01	TAS-100	06/17/15
	ARTZ-004-02-01	TAS-100	05/06/19
	(addendum)		



3. LIMITATIONS

- 3.1** Fire classification is not part of this acceptance.
- 3.2** For mortar or adhesive set tile applications, a static field uplift test in accordance with TAS 106 may be required, refer to applicable building code.
- 3.3** Applicant shall retain the services of a Miami-Dade County Certified Laboratory to perform quarterly test in accordance with TAS 112, appendix 'A'. Such testing shall be submitted to the Building Code Compliance Office for review.
- 3.4** Minimum underlayments shall be in compliance with instructions listed in the approved assemblies herein.
- 3.5** 30/90 hot mopped underlayment applications may be installed perpendicular to the roof slope unless stated otherwise by the underlayment material manufacturers published literature.
- 3.6** This acceptance is for wood deck applications. Minimum deck requirements shall be in compliance with applicable building code.
- 3.7** When using Steel or Aluminum Pan tile, panels must be clean to ensure proper adhesion.
- 3.8** The maximum designed pressure listed herein shall be applicable to all roof pressure zones (i.e. field, perimeters, and corners). Neither rational analysis, nor extrapolation shall be permitted for enhanced fastening at enhanced pressure zones (i.e. perimeters, extended corners and corners).



4. APPROVED ASSEMBLIES:

System A(1):	Handmade Barrel Tile with Steel Pan adhered with ICP Polyset® AH-160
Deck Type:	Wood, Non-Insulated
Deck Description:	New Construction ¹⁹ / ₃₂ " or greater plywood or wood plank. In reroofing, where the deck is less than ¹⁹ / ₃₂ " thick (Minimum ¹⁵ / ₃₂ "). The above attachment method must be in addition to existing attachment.
Slope Range:	2": 12" or greater
Maximum Uplift Pressure:	See Data for Attachment Calculations Below

INSTALLATION

1. World Class Two Piece Handmade Tapered Mission Roofing Tile" and its components shall be installed in strict compliance with Roofing Application Standard RAS 120. (See Detail A).
2. Data For Attachment Calculations:

Table 1: Average Weight (W) and Dimensions (l x w)

Tile Profile	Weight-W (lbf)	Length-l (ft)	Width-w (ft)
Handmade Tapered Mission Tile/Steel Pan	5.2	1.5	0.667

Table 2: Aerodynamic Multipliers - λ (ft³)

Tile Profile	λ (ft ³) Batten Application	λ (ft ³) Direct Deck Application
Handmade Tapered Mission Tile/Steel Pan	N/A	0.22

Table 3: Restoring Moments due to Gravity - M_g (ft-lbf)

Tile Profile	2":12"	3":12"	4":12"	5":12"	6":12"	7":12"
Handmade Tapered Mission Tile/Steel Pan	5.13	5.05	4.93	4.77	4.56	4.29

**Table 4: Attachment Resistance Expressed as a Moment - M_r (ft-lbf)
for Mortar or Adhesive¹ Set Systems**

Tile Profile	Tile Application	Attachment Resistance
Handmade Tapered Mission Tile/Steel Pan	ICP Adhesive Polyset® AH-160	39.57 ²

1. See foam adhesive manufacturer's component approval for installation requirements
2. Place 9.3 grams **per step** of pan and 5 grams on each side of cap of Polyset® AH-160



System A(2): **Handmade Barrel Tile with Aluminum Pan #1 adhered with ICP Polyset® AH-160**
Deck Type: Wood, Non-Insulated
Deck Description: New Construction ¹⁹/₃₂" or greater plywood or wood plank. In reroofing, where the deck is less than ¹⁹/₃₂" thick (Minimum ¹⁵/₃₂"). The above attachment method must be in addition to existing attachment.
Slope Range: 2": 12" or greater
Maximum Uplift Pressure: See Data for Attachment Calculations Below

INSTALLATION

- World Class Two Piece Handmade Tapered Mission Roofing Tile" and its components shall be installed in strict compliance with Roofing Application Standard RAS 120. (See Detail B).
- Data For Attachment Calculations:

Table 1: Average Weight (W) and Dimensions (l x w)

Tile Profile	Weight-W (lbf)	Length-l (ft)	Width-w (ft)
Handmade Tapered Mission Tile/Aluminum Pan #1	5.2	1.5	0.667

Table 2: Aerodynamic Multipliers - λ (ft³)

Tile Profile	λ (ft ³) Batten Application	λ (ft ³) Direct Deck Application
Handmade Tapered Mission Tile/Aluminum Pan #1	N/A	0.22

Table 3: Restoring Moments due to Gravity - M_g (ft-lbf)

Tile Profile	2":12"	3":12"	4":12"	5":12"	6":12"	7":12"
Handmade Tapered Mission Tile/Aluminum Pan #1	5.08	5.01	4.89	4.74	4.54	4.28

**Table 4: Attachment Resistance Expressed as a Moment - M_f (ft-lbf)
for Mortar or Adhesive Set Systems**

Tile Profile	Tile Application	Attachment Resistance
Handmade Tapered Mission Tile/Aluminum Pan #1	ICP Adhesive Polyset® AH-160	190.84 ³

- Place 31.9 grams **per step** of pan and 17.5 grams on each side of cap of Polyset® AH-160



System A(3): **Handmade Barrel Tile or Rustic Machine Barrel Tile with Aluminum Pan #2 adhered with Touch ‘n Seal® StormBond™**

Deck Type: Wood, Non-Insulated

Deck Description: New Construction ^{19/32}” or greater plywood or wood plank. In reroofing, where the deck is less than ^{19/32}” thick (Minimum ^{15/32}”). The above attachment method must be in addition to existing attachment.

Slope Range: 2": 12" or greater

Maximum Uplift Pressure: See Data for Attachment Calculations Below

INSTALLATION

1. World Class Two Piece Handmade Tapered Mission Roofing Tile” and its components shall be installed in strict compliance with Roofing Application Standard RAS 120. (See Detail C).
2. Data For Attachment Calculations:

Table 1: Average Weight (W) and Dimensions (l x w)

Tile Profile	Weight-W (lbf)	Length-l (ft)	Width-w (ft)
Handmade Tapered Mission Tile or Rustic Machine Barrel Tile / Aluminum Pan #2	5.2	1.5	0.667

Table 2: Aerodynamic Multipliers - λ (ft³)

Tile Profile	λ (ft ³) Batten Application	λ (ft ³) Direct Deck Application
Handmade Tapered Mission Tile or Rustic Machine Barrel Tile / Aluminum Pan #2	N/A	0.21

Table 3: Restoring Moments due to Gravity - M_g (ft-lbf)

Tile Profile	2":12"	3":12"	4":12"	5":12"	6":12"	7":12"
Handmade Tapered Mission Tile or Rustic Machine Barrel Tile / Aluminum Pan #2	2.81	2.77	2.72	2.66	2.59	2.51



**Table 4: Attachment Resistance Expressed as a Moment - M_f (ft-lbf)
for Mortar or Adhesive Set Systems**

Tile Profile	Tile Application	Attachment Resistance
Rustic Machine Barrel Tile/Aluminum Pan #2	Touch 'n Seal® StormBond™	92.5 ⁴
Handmade Tapered Mission Tile/Aluminum Pan #2	Touch 'n Seal® StormBond™	71.2 ⁵
4. Place 7.8 grams per step of 8.5" wide pan and 8.4 grams on each side of cap of StormBond™ Roof Tile Adhesive		
5. Place 16.7 grams per step of 8.5" wide pan and 12.1 grams on each side of cap of StormBond™ Roof Tile Adhesive		
Note: All aluminum pan #2's greater than 8.5" wide must be installed in a full bed of StormBond™ Roof Tile Adhesive		



System A(4):	ArteZanos® Tegole Tile with Aluminum Pan #2 adhered with Touch ‘n Seal® StormBond™
Deck Type:	Wood, Non-Insulated
Deck Description:	New Construction ¹⁹ / ₃₂ ” or greater plywood or wood plank. In reroofing, where the deck is less than ¹⁹ / ₃₂ ” thick (Minimum ¹⁵ / ₃₂ ”). The above attachment method must be in addition to existing attachment.
Slope Range:	2": 12" or greater
Maximum Uplift Pressure:	See Data for Attachment Calculations Below

INSTALLATION

1. ArteZanos® Tegole Tile and its components shall be installed in strict compliance as noted below.
(See Detail D).

Deck Attachment:	In accordance with applicable Building Code, but in no case shall it be less than 8d annular ring shank nails spaced 6” o.c. In reroofing, where the deck is less than ¹⁹ / ₃₂ ” thick (Minimum ¹⁵ / ₃₂ ”). The above attachment method must be in addition to existing attachment.
Underlayment:	One layer of Sharkskin Ultra® mechanically fastened to the deck with approved roofing nails and tin caps spaced 6” o.c. at the 4” horizontal overlap and 10” o.c. in a grid pattern having three equally spaced, staggered rows in the field of the sheet followed by one layer of Sharkskin Ultra SA®. Sharkskin Ultra SA® shall be applied with a minimum 2” horizontal end lap and minimum 6” vertical overlaps. Back nail to deck with approved annular ring shank nails and tin caps at a maximum of 12” o.c. at the side laps and 6” o.c. at the end laps.
Valleys, Rakes, Ridges, Eaves, Penetrations:	Shall be constructed in compliance with Roofing Application Standard RAS 120 and with ArteZanos®, Inc.’s published installation instructions.
Aluminum Pan #2:	Install pans using Touch ‘n Seal® StormBond™ Roof Tile Adhesive. Place one 5” long x 2” bead (5.5 grams) of under the 2” step at the nose of the pan. Place a “U” shaped 2” wide bead (24.5 grams) applied to the underside of the pan down each side and across the head of the pan. Note: All aluminum pan #2’s greater than 8.5” wide must be installed in a full bed of StormBond™ Roof Tile Adhesive
ArteZanos® Tegole Tile:	Apply a 2” wide bead (15.5 grams) of Touch ‘n Seal® StormBond™ Roof Tile Adhesive to the underside of the cap tile on each side of the tile.



2. Data For Attachment Calculations:

Table 1: Average Weight (W) and Dimensions (l x w)			
Tile Profile	Weight-W (lbf)	Length-l (ft)	Width-w (ft)
ArteZanos®Tegole Tile/Aluminum Pan #2	6.674	1.125	0.79

Table 2: Aerodynamic Multipliers - λ (ft³)		
Tile Profile	λ (ft³) Batten Application	λ (ft³) Direct Deck Application
ArteZanos®Tegole Tile/Aluminum Pan #2	N/A	0.14

Table 3: Restoring Moments due to Gravity - M_g (ft-lbf)						
Tile Profile	2":12"	3":12"	4":12"	5":12"	6":12"	7":12"
ArteZanos®Tegole Tile/Aluminum Pan #2	3.65	3.60	3.53	3.45	3.35	3.24

Table 4: Attachment Resistance Expressed as a Moment - M_r (ft-lbf) for Mortar or Adhesive Set Systems		
Tile Profile	Tile Application	Attachment Resistance
ArteZanos®Tegole Tile/Aluminum Pan #2	Touch 'n Seal® StormBond™ Roof Tile Adhesive	110.54 ⁶
6. Refer to Installation Guidelines above for adhesive size and quantity.		



System A(5):	Handmade Barrel Tile with Aluminum Pan #2 adhered with Touch ‘n Seal® StormBond™
Deck Type:	Wood, Non-Insulated
Deck Description:	New Construction ¹⁹ / ₃₂ ” or greater plywood or wood plank. In reroofing, where the deck is less than ¹⁹ / ₃₂ ” thick (Minimum ¹⁵ / ₃₂ ”). The above attachment method must be in addition to existing attachment.
Slope Range:	2": 12" or greater
Maximum Uplift Pressure:	See Data for Attachment Calculations Below

INSTALLATION

1. ArteZanos® Handmade Barrel Tile and its components shall be installed in strict compliance as noted below. (See Detail E).

Deck Description:	In accordance with applicable Building Code, but in no case shall it be less than 8d annular ring shank nails spaced 6” o.c. In reroofing, where the deck is less than ¹⁹ / ₃₂ ” thick (Minimum ¹⁵ / ₃₂ ”). The above attachment method must be in addition to existing attachment.
Underlayment:	One layer of Sharkskin Ultra® mechanically fastened to the deck with approved roofing nails and tin caps spaced 6” o.c. at the 4” horizontal overlap and 10” o.c. in a grid pattern having three equally spaced, staggered rows in the field of the sheet followed by one layer of Sharkskin Ultra SA®. Sharkskin Ultra SA® shall be applied with a minimum 2” horizontal end lap and minimum 6” vertical overlaps. Back nail to deck with approved annular ring shank nails and tin caps at a maximum of 12” o.c. at the side laps and 6” o.c. at the end laps.
Valleys, Rakes, Ridges, Eaves, Penetrations:	Shall be constructed in compliance with Roofing Application Standard RAS 120 and with ArteZanos®, Inc.’s published installation instructions.
Aluminum Pan #2:	Install pans using Touch ‘n Seal® StormBond™ Roof Tile Adhesive. Place one 5” long x 2” bead (5.5 grams) of under the 2” step at the nose of the pan. Place a “U” shaped 2” wide bead (24.5 grams) applied to the underside of the pan down each side and across the head of the pan. Note: All aluminum pan #2’s greater than 8.5” wide must be installed in a full bed of StormBond™ Roof Tile Adhesive
Handmade Barrel Tile:	Apply a 2” wide bead (15.5 grams) of Touch ‘n Seal® StormBond™ Roof Tile Adhesive to the underside of the cap tile on each side of the tile.



2. Data For Attachment Calculations:

Table 1: Average Weight (W) and Dimensions (l x w)			
Tile Profile	Weight-W (lbf)	Length-l (ft)	Width-w (ft)
Handmade Tapered Mission Tile/Aluminum Pan #2	6.290	1.5	0.667

Table 2: Aerodynamic Multipliers - λ (ft³)		
Tile Profile	λ (ft³) Batten Application	λ (ft³) Direct Deck Application
Handmade Tapered Mission Tile/Aluminum Pan #2	N/A	0.23

Table 3: Restoring Moments due to Gravity - M_g (ft-lbf)						
Tile Profile	2":12"	3":12"	4":12"	5":12"	6":12"	7":12"
Handmade Tapered Mission Tile/Aluminum Pan #2	4.69	4.64	4.56	4.46	4.34	4.21

Table 4: Attachment Resistance Expressed as a Moment - M_f (ft-lbf) for Mortar or Adhesive Set Systems		
Tile Profile	Tile Application	Attachment Resistance
Handmade Tapered Mission Tile/Aluminum Pan #2	Touch 'n Seal® StormBond™ Roof Tile Adhesive	171 ⁷
7. Refer to Installation Guidelines above for adhesive size and quantity.		



System A(6):	Handmade Barrel Tile with Aluminum Pan #2 adhered with Touch ‘n Seal® StormBond™ with Pex-AL-Pex Tubing or Oxygenated Pex Tubing or Non-Oxygenated Pex Tubing.
Deck Type:	Wood, Non-Insulated
Deck Description:	New Construction ¹⁹ / ₃₂ " or greater plywood or wood plank. In reroofing, where the deck is less than ¹⁹ / ₃₂ " thick (Minimum ¹⁵ / ₃₂ "). The above attachment method must be in addition to existing attachment.
Slope Range:	2": 12" or greater
Maximum Uplift Pressure:	See Data for Attachment Calculations Below

INSTALLATION

1. ArteZanos® Handmade Barrel Tile and its components shall be installed in strict compliance as noted below. (See Detail F).

Deck Description: ¹⁵/₃₂" or greater plywood or wood plank, fastened at 24" spans with #8d ring shank nails at 6" o.c.

Underlayment: Underlayment shall be installed in strict compliance with Roofing Application Standard RAS 120.

Valleys, Rakes, Ridges, Eaves, Penetrations: Shall be constructed in compliance with Roofing Application Standard RAS 120 and with ArteZanos®, Inc.’s published installation instructions.

Pex-AL-Pex Tubing, and Non-Oxygenated Pex Tubing: Pex tubing is laid over the underlayment and preliminarily installed as per manufacturer’s instructions. Only install using adhesive. Mechanical attachment to the deck is not allowed for this system. All applicable sections of the Florida Building Code must be strictly adhered to.

Aluminum Pan #2: Install pans over the Pex-AL-Pex Tubing or Oxygenated Pex Tubing or Non-Oxygenated Pex Tubing using Touch ‘n Seal® StormBond™ Roof Tile Adhesive. Place one 5" long x 2" bead (5.5 grams) of under the 2" step at the nose of the pan. Place a “U” shaped 2" wide bead (21.4 grams) applied to the underside of the pan down each side and across the head of the pan.

Note: All aluminum pan #2’s greater than 8.5” wide must be installed in a full bed of StormBond™ Roof Tile Adhesive

Handmade Barrel Tile: Apply a 2" wide bead (16.3 grams) of Touch ‘n Seal® StormBond™ Roof Tile Adhesive to the underside of the cap tile on each side of the tile.



2. Data For Attachment Calculations:

Table 1: Average Weight (W) and Dimensions (l x w)			
Tile Profile	Weight-W (lbf)	Length-l (ft)	Width-w (ft)
Handmade Tapered Mission Tile/Aluminum Pan #2	5.918	1.5	0.667

Table 2: Aerodynamic Multipliers - λ (ft³)		
Tile Profile	λ (ft³) Batten Application	λ (ft³) Direct Deck Application
Handmade Tapered Mission Tile/Aluminum Pan #2	N/A	0.23

Table 3: Restoring Moments due to Gravity - M_g (ft-lbf)						
Tile Profile	2":12"	3":12"	4":12"	5":12"	6":12"	7":12"
Handmade Tapered Mission Tile/Aluminum Pan #2	4.3	4.2	4.08	3.94	3.79	3.63

Table 4: Attachment Resistance Expressed as a Moment - M_f (ft-lbf) for Mortar or Adhesive Set Systems		
Tile Profile	Tile Application	Attachment Resistance
Handmade Tapered Mission Tile/Aluminum Pan #2	Touch 'n Seal® StormBond™ Roof Tile Adhesive	74.8 ⁸

8. Refer to Installation Guidelines above for adhesive size and quantity.



System A(7):	Recover System - Handmade Barrel Tile with Aluminum Pan #2 adhered with Touch ‘n Seal® StormBond™ over existing asphalt shingle as specified herein.
Deck Type:	Wood, Non-Insulated
Deck Description:	New Construction ¹⁹ / ₃₂ ” or greater plywood or wood plank. In reroofing, where the deck is less than ¹⁹ / ₃₂ ” thick (Minimum ¹⁵ / ₃₂ ”). The above attachment method must be in addition to existing attachment.
Slope Range:	2": 12" or greater
Maximum Uplift Pressure:	- 60 psf (See Limitation 3.8 herein)

INSTALLATION

1. ArteZanos® Handmade Barrel Tile and its components shall be installed in strict compliance as noted below. (See Detail G).

Deck Description: Existing asphalt shingle roof system installed and permitted post 2001 Florida Building Code, High Velocity Hurricane Zone. Deck shall be verified to be minimum ¹⁵/₃₂" or greater plywood or wood plank, fastened at 24" spans with #8d ring shank nails at 6" o.c.

Underlayment: Over the existing shingle roof system, install one layer of Rex™Synfelt with 6-1/2" sidelaps, preliminarily attached with 12 ga. x 1-1/4" long ring shank roofing nails and 1-5/8" tin caps spaced 32" o.c. on the sidelaps and 24" o.c. in one row in the center of the sheet.

One layer of Sharkskin Ultra®, over the Rex™Synfelt, mechanically fastened to the deck with approved roofing nails and tin caps over (optional) magnetic self-sealing tin caps spaced 6" o.c. at the 4" horizontal overlap and 10" o.c. in a grid pattern having three equally spaced, staggered rows in the field of the sheet.

One 6-1/2" layer of Sharkskin Ultra SA shall be applied around the perimeter of the deck.

Valleys, Rakes, Ridges, Eaves, Penetrations: Shall be constructed in compliance with Roofing Application Standard RAS 120 and with ArteZanos®, Inc.’s published installation instructions.

Aluminum Pan #2: Install pans over optional Pex-Al-Pex Tubing or Oxygenated Pex Tubing or Non Oxygenated Pex Tubing using Touch ‘n Seal StormBond™ Roof Tile Adhesive. Place one 5" long x 2" bead (5.5 grams) of under the 2" step at the nose of the pan. Place a "U" shaped 2" wide bead (21.4 grams) applied to the underside of the pan down each side and across the head of the pan.

Note: All aluminum pan #2’s greater than 8.5” wide must be installed in a full bed of StormBond™ Roof Tile Adhesive

Handmade Barrel Tile: Apply a 2" wide bead (16.3 grams) of Touch ‘n Seal StormBond™ Roof Tile Adhesive to the underside of the cap tile on each side of the tile.

System A(8):	Recover System - Handmade Barrel Tile with Aluminum Pan #2 adhered with Touch ‘n Seal® StormBond™ over existing asphalt shingle as specified herein.
Deck Type:	Wood, Non-Insulated
Deck Description:	New Construction ¹⁹ / ₃₂ ” or greater plywood or wood plank. In reroofing, where the deck is less than ¹⁹ / ₃₂ ” thick (Minimum ¹⁵ / ₃₂ ”). The above attachment method must be in addition to existing attachment.
Slope Range:	2": 12" or greater
Maximum Uplift Pressure:	-97.5 psf (See Limitation 3.8 herein)

INSTALLATION

1. ArteZanos® Handmade Barrel Tile and its components shall be installed in strict compliance as noted below. (See Detail G).

Deck Description: Existing asphalt shingle roof system installed and permitted post 2001 Florida Building Code, High Velocity Hurricane Zone. Deck shall be verified to be minimum ¹⁵/₃₂" or greater plywood or wood plank, fastened at 24" spans with #8d ring shank nails at 6" o.c.

Underlayment: Over the existing shingle roof system, install one layer of Rex™Synfelt with 6-1/2" sidelaps, preliminarily attached with 12 ga. x 1-1/4" long ring shank roofing nails and 1-5/8" tin caps spaced 32" o.c. on the sidelaps and 24" o.c. in one row in the center of the sheet.

One layer of Sharkskin Ultra®, over the Rex™Synfelt, mechanically fastened to the deck with approved roofing nails and tin caps over (optional) magnetic self-sealing tin caps spaced 6" o.c. at the 4" horizontal overlap and 6" o.c. in a grid pattern having three equally spaced, staggered rows in the field of the sheet.

One 6-1/2" layer of Sharkskin Ultra SA shall be applied around the perimeter of the deck.

Valleys, Rakes, Ridges, Eaves, Penetrations: Shall be constructed in compliance with Roofing Application Standard RAS 120 and with ArteZanos®, Inc.’s published installation instructions.

Aluminum Pan #2: Install pans over optional Pex-Al-Pex Tubing or Oxygenated Pex Tubing or Non Oxygenated Pex Tubing using Touch ‘n Seal StormBond™ Roof Tile Adhesive. Place one 5" long x 2" bead (5.5 grams) of under the 2" step at the nose of the pan. Place a "U" shaped 2" wide bead (21.4 grams) applied to the underside of the pan down each side and across the head of the pan.

Note: All aluminum pan #2’s greater than 8.5” wide must be installed in a full bed of StormBond™ Roof Tile Adhesive

Handmade Barrel Tile: Apply a 2" wide bead (16.3 grams) of Touch ‘n Seal StormBond™ Roof Tile Adhesive to the underside of the cap tile on each side of the tile.

System A(9):	Handmade Barrel Tile with Aluminum Pan #2 adhered with Touch ‘n Seal® StormBond™
Deck Type:	Wood, Non-Insulated
Deck Description:	New Construction ¹⁹ / ₃₂ ” or greater plywood or wood plank. In reroofing, where the deck is less than ¹⁹ / ₃₂ ” thick (Minimum ¹⁵ / ₃₂ ”). The above attachment method must be in addition to existing attachment.
Slope Range:	2": 12" or greater
Maximum Uplift Pressure:	See Data for Attachment Calculations Below

INSTALLATION

ArteZanos® Handmade Barrel Tile and its components shall be installed in strict compliance as noted below. (See Detail G).

Deck Description:	In accordance with applicable Building Code, but in no case shall it be less than 8d annular ring shank nails spaced 6” o.c. In reroofing, where the deck is less than ¹⁹ / ₃₂ ” thick (Minimum ¹⁵ / ₃₂ ”). The above attachment method must be in addition to existing attachment.
Underlayment:	One layer of Sharkskin Ultra® mechanically fastened to the deck with approved roofing nails and tin caps over magnetic self-sealing tin caps spaced 6” o.c. at the 4” horizontal overlap and 10” o.c. in a grid pattern having three equally spaced, staggered rows in the field of the sheet.
Valleys, Rakes, Ridges, Eaves, Penetrations:	Shall be constructed in compliance with Roofing Application Standard RAS 120 and with ArteZanos®, Inc.’s published installation instructions.
Aluminum Pan #2:	Install pans using Touch ‘n Seal® StormBond™ Roof Tile Adhesive. Place one 5” long x 2” bead (5.5 grams) of under the 2” step at the nose of the pan. Place a “U” shaped 2” wide bead (42.5 grams) applied to the underside of the pan down each side and across the head of the pan. Note: All aluminum pan #2’s greater than 8.5” wide must be installed in a full bed of StormBond™ Roof Tile Adhesive
Handmade Barrel Tile:	Apply a 2” wide bead (19 grams) of Touch ‘n Seal® StormBond™ Roof Tile Adhesive to the underside of the cap tile on each side of the tile.

2. Data For Attachment Calculations:

Table 1: Average Weight (W) and Dimensions (l x w)			
Tile Profile	Weight-W (lbf)	Length-l (ft)	Width-w (ft)
Handmade Tapered Mission Tile/Aluminum Pan #2	6.290	1.5	0.667



Table 2: Aerodynamic Multipliers - λ (ft³)		
Tile Profile	λ (ft³) Batten Application	λ (ft³) Direct Deck Application
Handmade Tapered Mission Tile/Aluminum Pan #2	N/A	0.23

Table 3: Restoring Moments due to Gravity - M_g (ft-lbf)						
Tile Profile	2":12"	3":12"	4":12"	5":12"	6":12"	7":12"
Handmade Tapered Mission Tile/Aluminum Pan #2	4.69	4.63	4.55	4.44	4.32	4.19

Table 4: Attachment Resistance Expressed as a Moment - M_r (ft-lbf) for Mortar or Adhesive Set Systems		
Tile Profile	Tile Application	Attachment Resistance
Handmade Tapered Mission Tile/Aluminum Pan #2	Touch 'n Seal® StormBond™ Roof Tile Adhesive	163 ⁹
9. Refer to Installation Guidelines above for adhesive size and quantity.		



System A(10):	Handmade Barrel Tile with Aluminum Pan #2 adhered with Touch ‘n Seal® StormBond™
Deck Type:	Wood, Non-Insulated
Deck Description:	New Construction ¹⁹ / ₃₂ ” or greater plywood or wood plank. In reroofing, where the deck is less than ¹⁹ / ₃₂ ” thick (Minimum ¹⁵ / ₃₂ ”). The above attachment method must be in addition to existing attachment.
Slope Range:	2": 12" or greater
Maximum Uplift Pressure:	-52.5 psf (See Limitation 3.8 herein)

INSTALLATION

ArteZanos® Handmade Barrel Tile and its components shall be installed in strict compliance as noted below. (See Detail G).

Deck Description:	In accordance with applicable Building Code, but in no case shall it be less than 8d annular ring shank nails spaced 6” o.c. In reroofing, where the deck is less than ¹⁹ / ₃₂ ” thick (Minimum ¹⁵ / ₃₂ ”). The above attachment method must be in addition to existing attachment.
Underlayment:	One layer of Sharkskin Ultra® mechanically fastened to the deck with approved roofing nails and tin caps over magnetic self-sealing tin caps on top of spaced 6” o.c. at the 4” horizontal overlap and 10” o.c. in a grid pattern having three equally spaced, staggered rows in the field of the sheet.
Valleys, Rakes, Ridges, Eaves, Penetrations:	Shall be constructed in compliance with Roofing Application Standard RAS 120 and with ArteZanos®, Inc.’s published installation instructions.
Aluminum Pan #2:	Install pans using Touch ‘n Seal StormBond™ Roof Tile Adhesive. Place one 5” long x 2” bead (5.5 grams) of under the 2” step at the nose of the pan. Place a “U” shaped 2” wide bead (21.4 grams) applied to the underside of the pan down each side and across the head of the pan. Note: All aluminum pan #2’s greater than 8.5” wide must be installed in a full bed of StormBond™ Roof Tile Adhesive
Handmade Barrel Tile:	Apply a 2” wide bead (16.3 grams) of Touch ‘n Seal StormBond™ Roof Tile Adhesive to the underside of the cap tile on each side of the tile.



System A(11):	Handmade Barrel Tile with Aluminum Pan #2 adhered with Touch ‘n Seal® StormBond™
Deck Type:	Wood, Non-Insulated
Deck Description:	New Construction ¹⁹ / ₃₂ ” or greater plywood or wood plank. In reroofing, where the deck is less than ¹⁹ / ₃₂ ” thick (Minimum ¹⁵ / ₃₂ ”). The above attachment method must be in addition to existing attachment.
Slope Range:	2": 12" or greater
Maximum Uplift Pressure:	-60 psf (See Limitation 3.8 herein)

INSTALLATION

1. ArteZanos® Handmade Barrel Tile and its components shall be installed in strict compliance as noted below. (See Detail G).

Deck Description: In accordance with applicable Building Code, but in no case shall it be less than 8d annular ring shank nails spaced 6” o.c. In reroofing, where the deck is less than ¹⁹/₃₂” thick (Minimum ¹⁵/₃₂”). The above attachment method must be in addition to existing attachment.

Underlayment: Install one layer of Rex™Synfelt with 6-1/2” sidelaps, preliminarily attached with 12 ga. x 1-1/4” long ring shank roofing nails and 1-5/8” tin caps spaced 32” o.c. on the sidelaps and 24” o.c. in one row in the center of the sheet.

One layer of Sharkskin Ultra®, over the Rex™Synfelt, mechanically fastened to the deck with approved roofing nails and tin caps over (optional) magnetic self-sealing tin caps spaced 6” o.c. at the 4” horizontal overlap and 10” o.c. in a grid pattern having three equally spaced, staggered rows in the field of the sheet.

One 6-1/2” layer of Sharkskin Ultra SA shall be applied around the perimeter of the deck.

Valleys, Rakes, Ridges, Eaves, Penetrations: Shall be constructed in compliance with Roofing Application Standard RAS 120 and with ArteZanos®, Inc.’s published installation instructions.

Aluminum Pan #2: Install pans over optional Pex-Al-Pex Tubing or Oxygenated Pex Tubing or Non Oxygenated Pex Tubing using Touch ‘n Seal StormBond™ Roof Tile Adhesive. Place one 5” long x 2” bead (5.5 grams) of under the 2” step at the nose of the pan. Place a “U” shaped 2” wide bead (21.4 grams) applied to the underside of the pan down each side and across the head of the pan.

Note: All aluminum pan #2’s greater than 8.5” wide must be installed in a full bed of StormBond™ Roof Tile Adhesive

Handmade Barrel Tile: Apply a 2” wide bead (16.3 grams) of Touch ‘n Seal StormBond™ Roof Tile Adhesive to the underside of the cap tile on each side of the tile.

System A(12):	Handmade Barrel Tile with Aluminum Pan #2 adhered with Touch ‘n Seal® StormBond™ with optional Pex-AL-Pex Tubing or Oxygenated Pex Tubing or Non-Oxygenated Pex Tubing.
Deck Type:	Wood, Non-Insulated
Deck Description:	New Construction $1\frac{19}{32}$ " or greater plywood or wood plank. In reroofing, where the deck is less than $1\frac{19}{32}$ " thick (Minimum $1\frac{15}{32}$ "). The above attachment method must be in addition to existing attachment.
Slope Range:	2": 12" or greater
Maximum Uplift Pressure:	See Data for Attachment Calculations Below

INSTALLATION

ArteZanos® Handmade Barrel Tile and its components shall be installed in strict compliance as noted below. (See Detail E).

Deck Description:	In accordance with applicable Building Code, but in no case shall it be less than 8d annular ring shank nails spaced 6" o.c. In reroofing, where the deck is less than $1\frac{19}{32}$ " thick (Minimum $1\frac{15}{32}$ "). The above attachment method must be in addition to existing attachment.
Underlayment:	<p>Install one layer of Rex™Synfelt with 6-1/2" sidelaps, preliminarily attached with 12 ga. x 1-1/4" long ring shank roofing nails and 1-5/8" tin caps spaced 32" o.c. on the sidelaps and 24" o.c. in one row in the center of the sheet.</p> <p>One layer of Sharkskin Ultra®, over the Rex™Synfelt, mechanically fastened to the deck with approved roofing nails and tin caps over (optional) magnetic self-sealing tin caps spaced 6" o.c. at the 4" horizontal overlap and 10" o.c. in a grid pattern having three equally spaced, staggered rows in the field of the sheet.</p> <p>One 6-1/2" layer of Sharkskin Ultra SA shall be applied around the perimeter of the deck.</p>
Valleys, Rakes, Ridges, Eaves, Penetrations:	Shall be constructed in compliance with Roofing Application Standard RAS 120 and with ArteZanos®, Inc.'s published installation instructions.
Aluminum Pan #2:	<p>Install pans over optional Pex-Al-Pex Tubing or Oxygenated Pex Tubing or Non Oxygenated Pex Tubing using Touch ‘n Seal StormBond™ Roof Tile Adhesive. Place two 5" long x 2" beads (5 grams each) under the 2" step at the nose of the pan. Place a "U" shaped 2" wide bead (25.8 grams) applied to the underside of the pan down each side and across the head of the pan.</p> <p>Note: All aluminum pan #2's greater than 8.5" wide must be installed in a full bed of StormBond™ Roof Tile Adhesive</p>
Handmade Barrel Tile:	Apply a 2" wide bead (14.6 grams) of Touch ‘n Seal® StormBond™ Roof Tile Adhesive to the underside of the cap tile on each side of the tile.

3. Data For Attachment Calculations:

Table 1: Average Weight (W) and Dimensions (l x w)			
Tile Profile	Weight-W (lbf)	Length-l (ft)	Width-w (ft)
Handmade Tapered Mission Tile/Aluminum Pan #2	6.290	1.5	0.667

Table 2: Aerodynamic Multipliers - λ (ft³)		
Tile Profile	λ (ft³) Batten Application	λ (ft³) Direct Deck Application
Handmade Tapered Mission Tile/Aluminum Pan #2	N/A	0.23

Table 3: Restoring Moments due to Gravity - M_g (ft-lbf)						
Tile Profile	2":12"	3":12"	4":12"	5":12"	6":12"	7":12"
Handmade Tapered Mission Tile/Aluminum Pan #2	5.26	5.2	5.1	4.98	4.84	4.69

Table 4: Attachment Resistance Expressed as a Moment - M_f (ft-lbf) for Mortar or Adhesive Set Systems		
Tile Profile	Tile Application	Attachment Resistance
Handmade Tapered Mission Tile/Aluminum Pan #2	Touch 'n Seal® StormBond™ Roof Tile Adhesive	100.9 ¹⁰
10. Refer to Installation Guidelines above for adhesive size and quantity.		



5. LABELING

- 5.1 All clay tiles shall bear the imprint or identifiable marking of the manufacturer's name or logo as detailed below, or following statement: "Miami-Dade County Product Control Approved".



ARTEZANOS® WORLD CLASS TILE LABEL
(LOCATED ON EITHER TOPSIDE OR UNDERSIDE OF TILE – MAY ALSO CONTAIN A LETTER
(A – Z) IN THE CENTER OF THE CIRCLE FOR TRACKING PURPOSES)

- 5.2 All metal panels shall be permanently labeled with the manufacturer's name and/or logo, city, state, and the following statement: "Miami-Dade County Product Control Approved" or with the Miami-Dade County Product Control Seal as seen below.

6. BUILDING PERMIT REQUIREMENTS

- 6.1 Application for building permit shall be accompanied by copies of the following:
- 6.1.1 This Notice of Acceptance.
 - 6.1.2 Any other documents required by the Building Official or applicable building code in order to properly evaluate the installation of this system.



PROFILE DRAWINGS

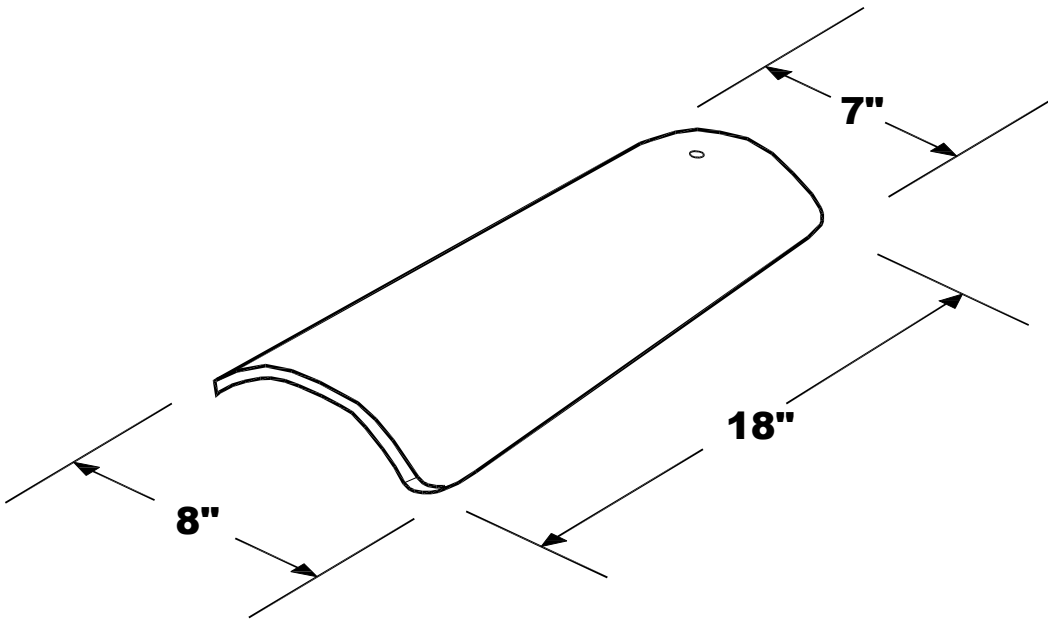

ARTEZANOS®, INC. "2 PIECE HANDMADE TAPERED MISSION BARREL TILE

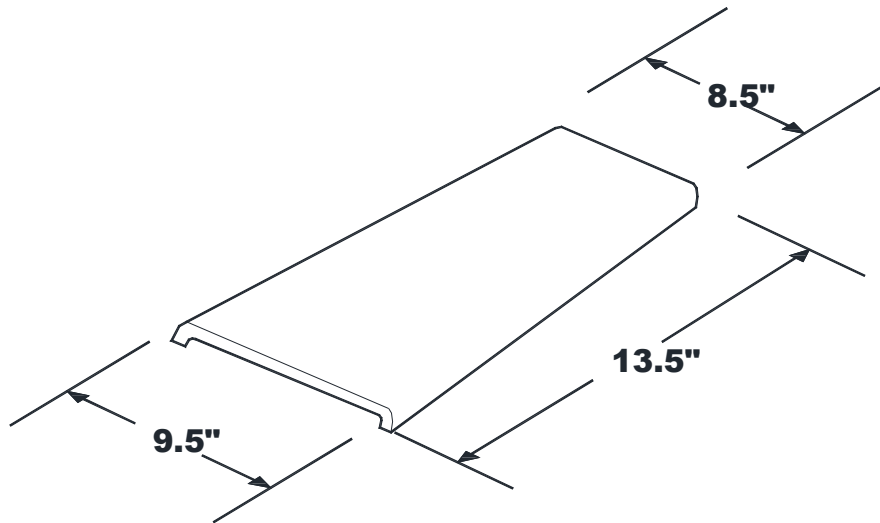

ARTEZANOS®, TEGOLE TILE



DETAIL A

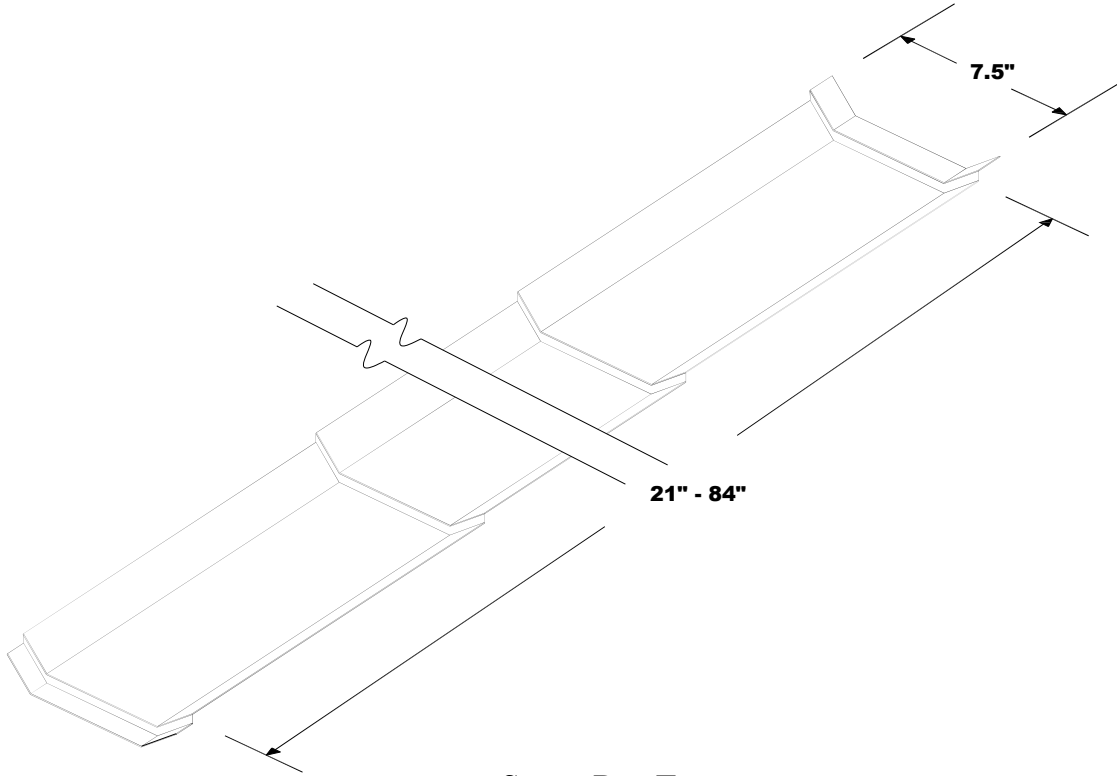

STEEL PAN TILE

**See System A(1)
for quantity.**

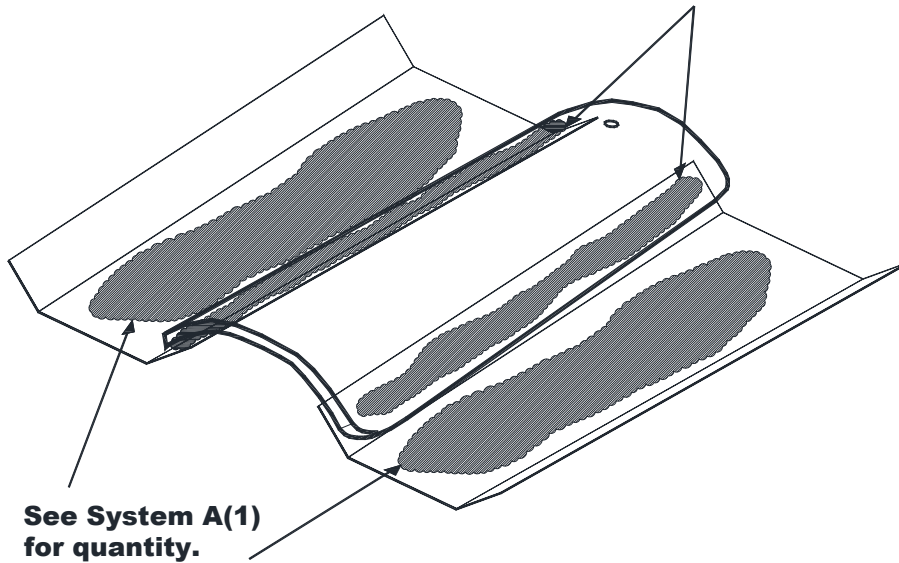

**See System A(1)
for quantity.**

HANDMADE TAPERED MISSION TILE / STEEL PAN DETAIL



DETAIL B

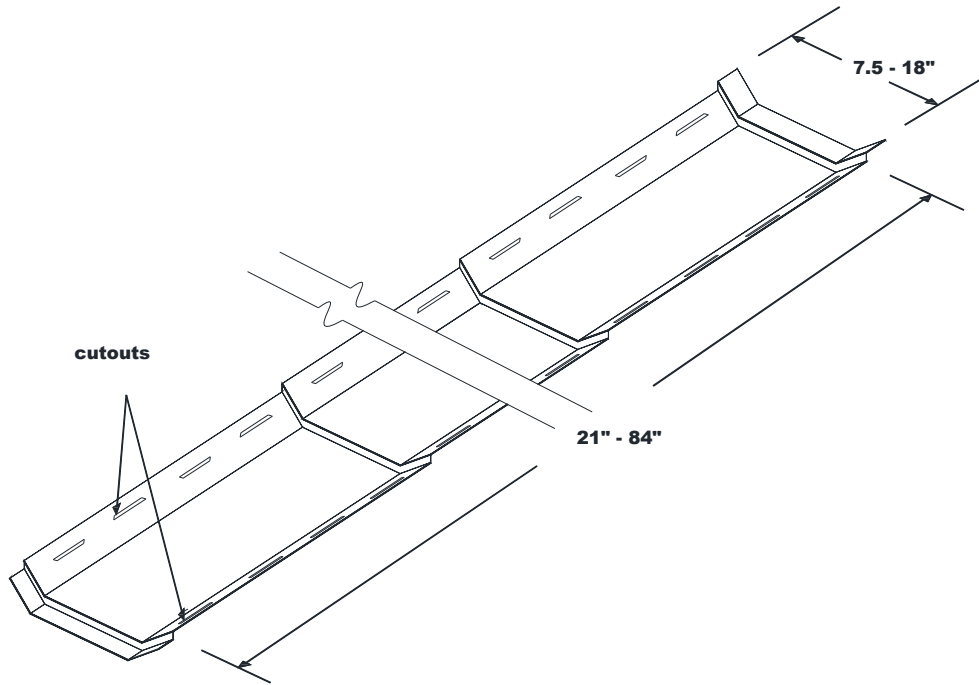

ALUMINUM PAN TILE #1

See System A(2)
for quantity.

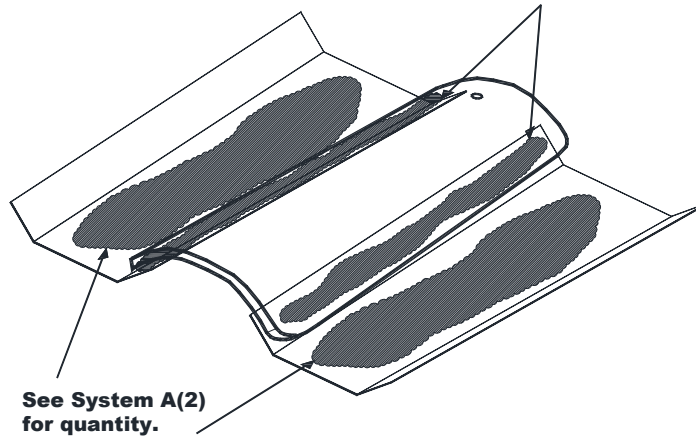

HANDMADE TAPERED MISSION TILE / ALUMINUM PAN #1 DETAIL



DETAIL C

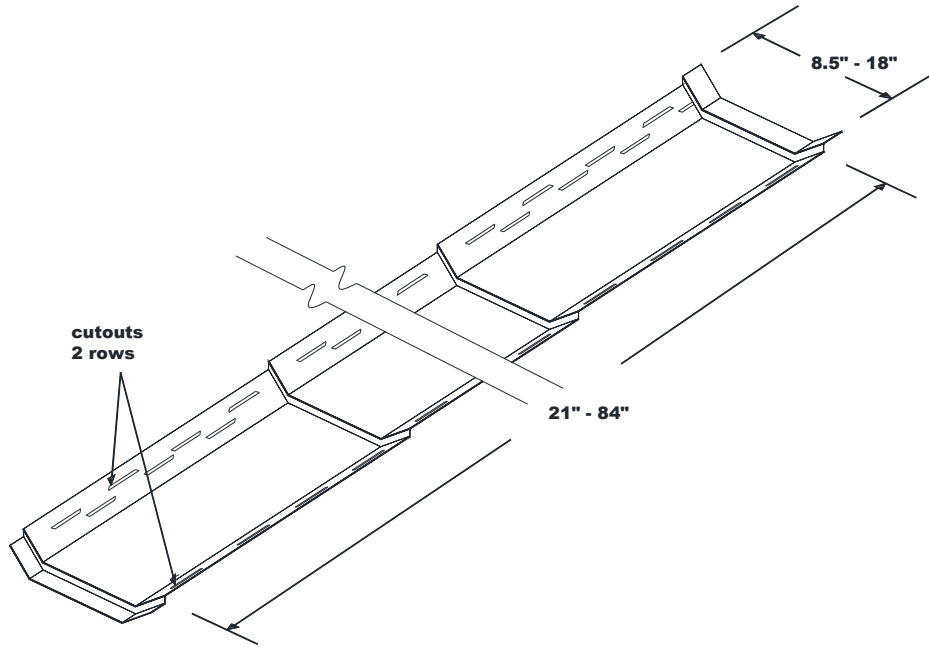

ALUMINUM PAN TILE #2

**See System A(3)
for quantity.**

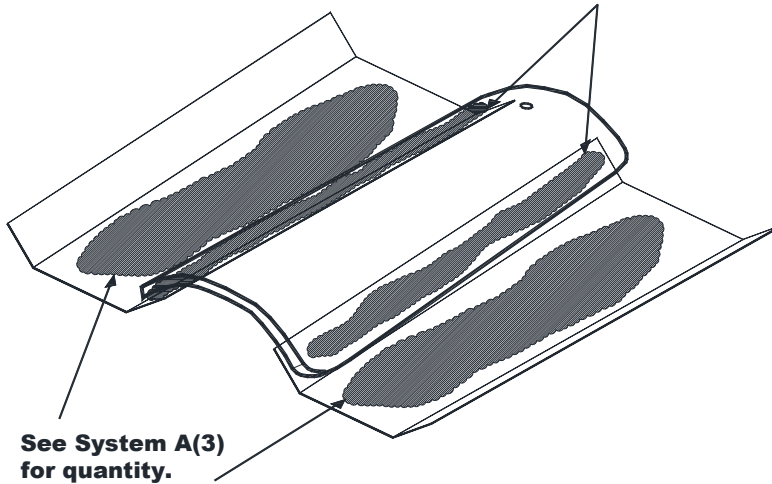

HANDMADE TAPERED MISSION TILE / ALUMINUM PAN #2 DETAIL



DETAIL D

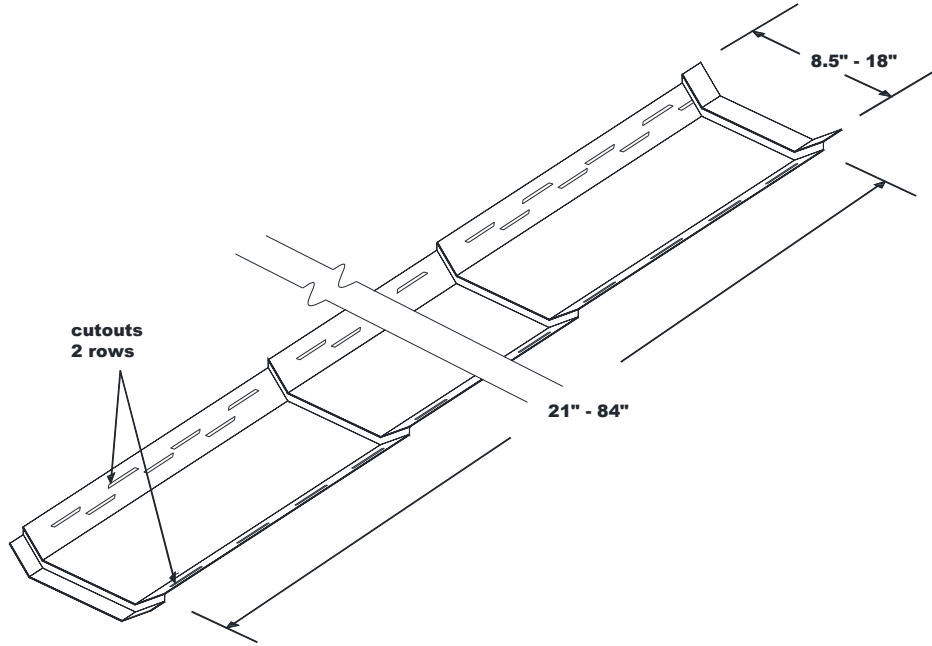

ALUMINUM PAN TILE #2

**See System A(4)
for quantity.**

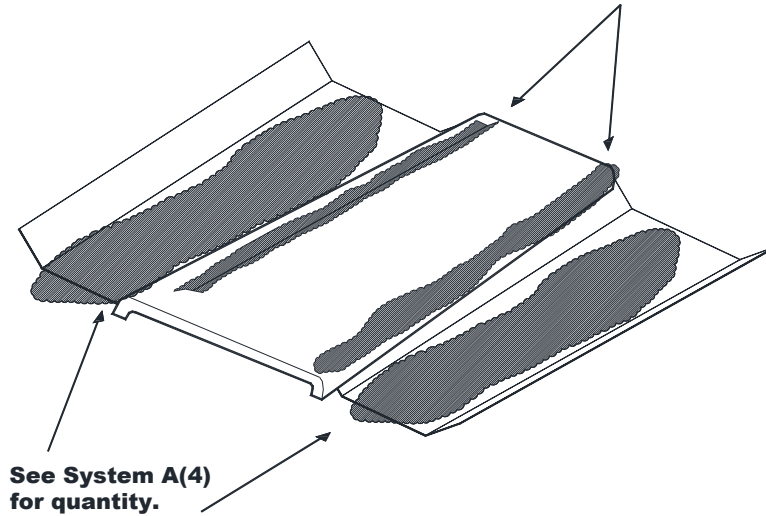

HANDMADE TAPERED MISSION TILE / ALUMINUM PAN #2 DETAIL



DETAIL E

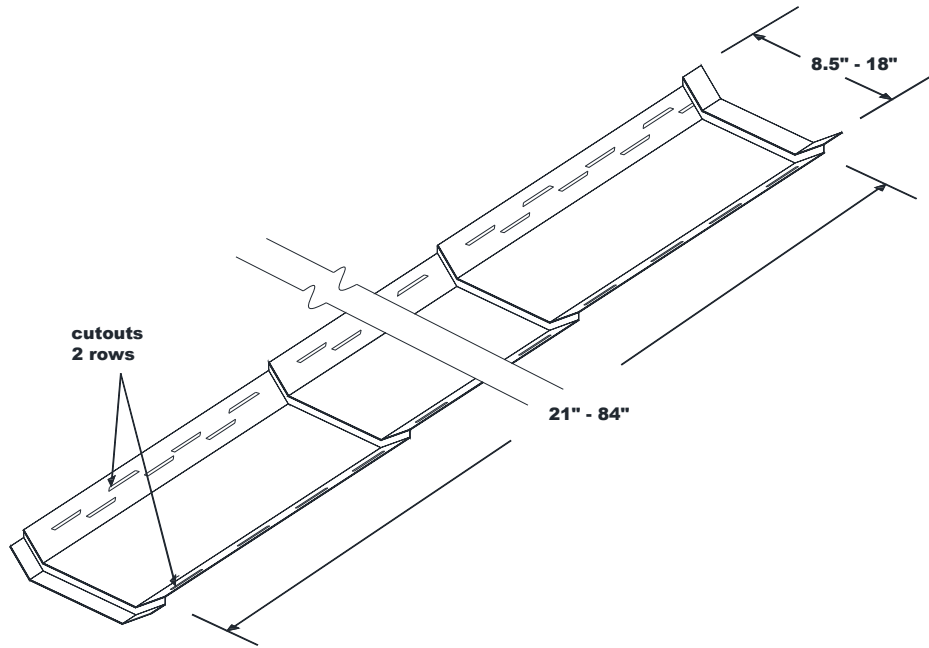

ALUMINUM PAN TILE #2

**See System A(5), and A(12)
for quantity.**

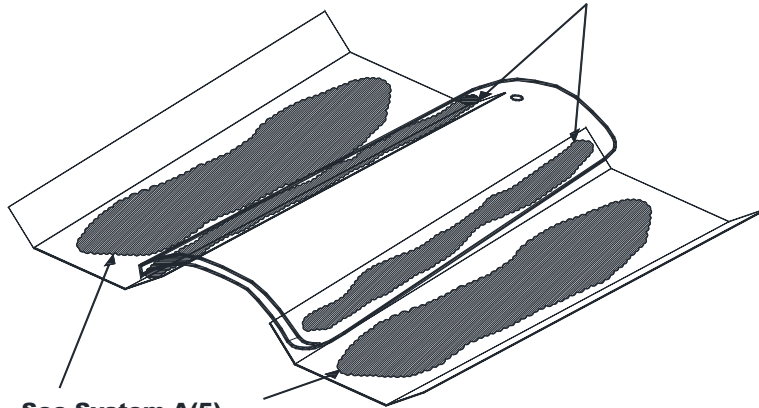

**See System A(5),
and A(12) or quantity.**

HANDMADE TAPERED MISSION TILE / ALUMINUM PAN #2 DETAIL



DETAIL F

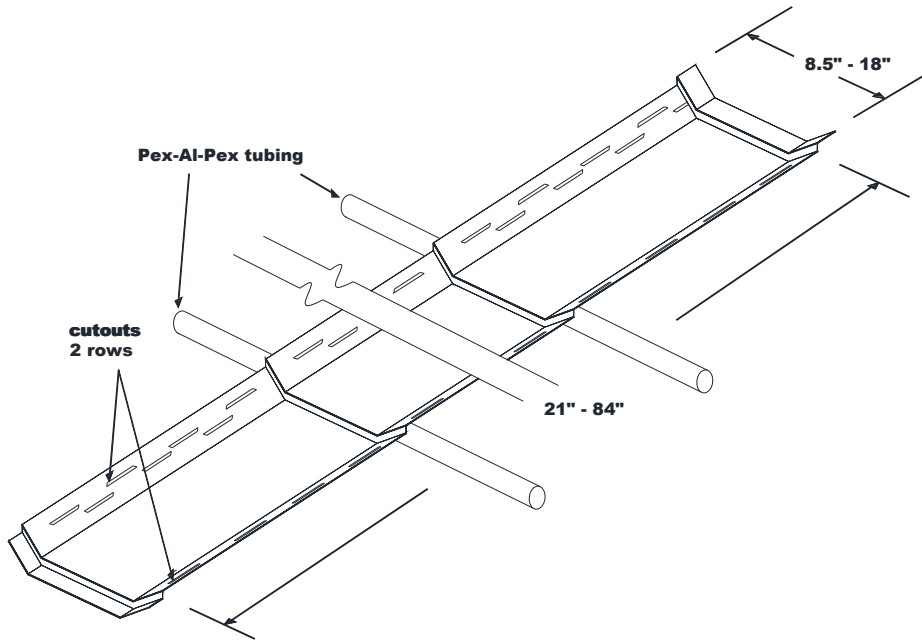

ALUMINUM PAN TILE #2

**See System A(6)
for quantity.**

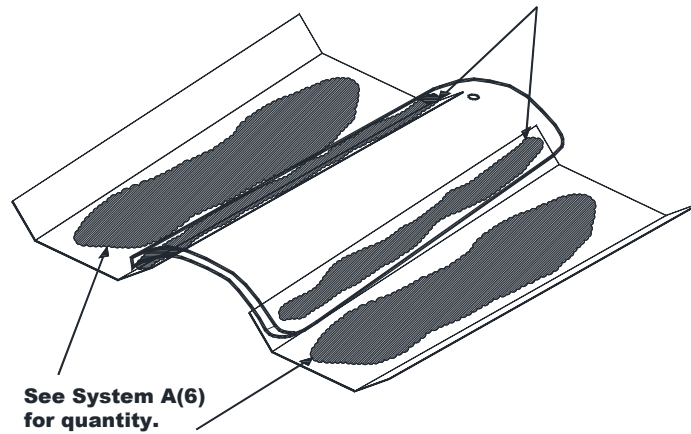

HANDMADE TAPERED MISSION TILE / ALUMINUM PAN #2 DETAIL



DETAIL G

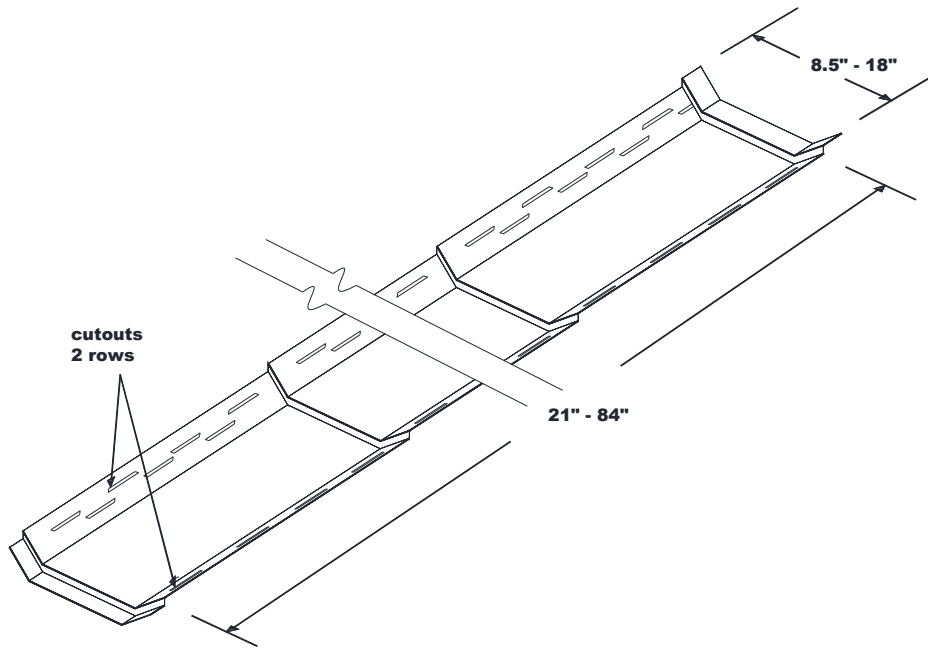

ALUMINUM PAN TILE #2

**See System A(7), A(8), A(9), and A(10)
for quantity.**

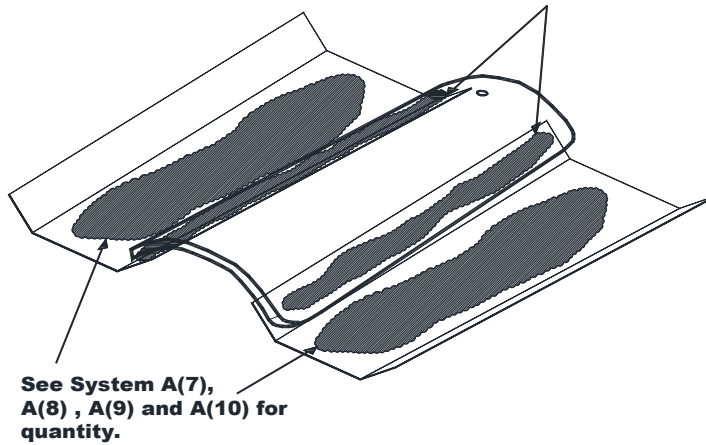

HANDMADE TAPERED MISSION TILE / ALUMINUM PAN #2 DETAIL

END OF THIS ACCEPTANCE



GREEN SUSTAINABLE ATTRIBUTES (GSA)

SCOPE: This document is solely for the purpose of verification of Sustainable Attributes of construction materials. The documentation submitted has been reviewed by Miami-Dade County Product Control Section.

G.6 - ROOF SYSTEM LIFE CYCLE

<u>Years</u>	<u>Assemblies:</u>
50	Systems A(1) – A(12)

G.7 - REGIONALLY MANUFACTURED COMPONENTS

<u>Component Name</u>	<u>Manufacturing Location</u>
1. ArteZanos Steel Pan	12471 SW 130 Street #8, Miami, FL.
2. ArteZanos Aluminum Pan	12471 SW 130 Street #8, Miami, FL.

