



DEPARTMENT OF REGULATORY AND ECONOMIC RESOURCES (RER)  
BOARD AND CODE ADMINISTRATION DIVISION

MIAMI-DADE COUNTY  
PRODUCT CONTROL SECTION  
11805 SW 26 Street, Room 208  
Miami, Florida 33175-2474  
T (786) 315-2590 F (786) 315-2599  
[www.miamidade.gov/pera](http://www.miamidade.gov/pera)

## NOTICE OF ACCEPTANCE (NOA)

**ArteZanos®, Inc.**  
9455 SW 78<sup>th</sup> Street  
Miami, FL 33173

### SCOPE:

This NOA is being issued under the applicable rules and regulations governing the use of construction materials. The documentation submitted has been reviewed and accepted by Miami-Dade County RER - Product Control Section to be used in Miami Dade County and other areas where allowed by the Authority Having Jurisdiction (AHJ).

This NOA shall not be valid after the expiration date stated below. The Miami-Dade County Product Control Section (In Miami Dade County) and/or the AHJ (in areas other than Miami Dade County) reserve the right to have this product or material tested for quality assurance purposes. If this product or material fails to perform in the accepted manner, the manufacturer will incur the expense of such testing and the AHJ may immediately revoke, modify, or suspend the use of such product or material within their jurisdiction. RER reserves the right to revoke this acceptance, if it is determined by Miami-Dade County Product Control Section that this product or material fails to meet the requirements of the applicable building code.

This product is approved as described herein, and has been designed to comply with the Florida Building Code including the High Velocity Hurricane Zone of the Florida Building Code.

### DESCRIPTION: Arguey “S” Clay Tile

**LABELING:** Each unit shall bear a permanent label with the manufacturer's name or logo, city, state and following statement: "Miami-Dade County Product Control Approved", unless otherwise noted herein.

**RENEWAL** of this NOA shall be considered after a renewal application has been filed and there has been no change in the applicable building code negatively affecting the performance of this product.

**TERMINATION** of this NOA will occur after the expiration date or if there has been a revision or change in the materials, use, and/or manufacture of the product or process. Misuse of this NOA as an endorsement of any product, for sales, advertising or any other purposes shall automatically terminate this NOA. Failure to comply with any section of this NOA shall be cause for termination and removal of NOA.

**ADVERTISEMENT:** The NOA number preceded by the words Miami-Dade County, Florida, and followed by the expiration date may be displayed in advertising literature. If any portion of the NOA is displayed, then it shall be done in its entirety.

**INSPECTION:** A copy of this entire NOA shall be provided to the user by the manufacturer or its distributors and shall be available for inspection at the job site at the request of the Building Official.

This NOA renews NOA# 18-1212.09 and consists of pages 1 through 8.  
The submitted documentation was reviewed by Alex Tigera.

12/21/23



NOA No.: 23-1025.05  
Expiration Date: 12/14/28  
Approval Date: 12/21/23  
Page 1 of 8

## ROOFING ASSEMBLY APPROVAL

**Category:** Roofing  
**Sub-Category:** Roofing Tiles  
**Material:** Clay

### 1. SCOPE

This approves a roofing system using **ArteZanos® Arguey ‘S’ Clay Roof Tile**, as manufactured by **Mundo Negocios Export SAS** in **Cucuta, Colombia** and distributed by **ArteZanos®, Inc.** as described in Section 2 of this Notice of Acceptance. For the locations where the pressure requirements, as determined by applicable Building Code, does not exceed the values listed in section 4 herein. The attachment calculations shall be done as a moment based system.

### 2. PRODUCT DESCRIPTION

<u>Manufactured by Applicant</u>	<u>Dimensions</u>	<u>Test Specifications</u>	<u>Product Description</u>
Arguey ‘S’ Clay Tile	l = 18" w = 11" ½" thick	ASTM C 1167	High profile ‘S’ shaped handmade clay roof tile. For direct deck, adhesive set applications.
Trim Pieces	l = varies w = varies varying thickness	ASTM C 1167	Accessory trim, clay roof pieces for use at hips, rakes, ridges and valley terminations. Manufactured for each tile profile.

#### 2.1 MANUFACTURING LOCATION

1. Cucuta, Colombia

#### 2.2 SUBMITTED EVIDENCE:

<u>Test Agency</u>	<u>Test Identifier</u>	<u>Test Name/Report</u>	<u>Date</u>
IBA Consultants, Inc.	2352-5	ASTM C 1167	2003
	2352-4	TAS 101	June 2000
	2352-4	Calculations	October 2000
American Test Lab of South Florida	RT1201.01-23	ASTM C 1167	12/08/23
	RT1124.02-18	TAS 101	11/24/18
	RT1101.02-18	TAS 101	11/1/18



NOA No.: 23-1025.05  
Expiration Date: 12/14/28  
Approval Date: 12/21/23  
Page 2 of 8

### 3. LIMITATIONS

- 3.1 Fire classification is not part of this acceptance.
- 3.2 For mortar or adhesive set tile applications, a static field uplift test shall be performed in accordance with TAS 106.
- 3.3 Applicant shall retain the services of a Miami-Dade County Certified Laboratory to perform quarterly test in accordance with TAS 112, appendix 'A'. Such testing shall be submitted to the Building Code Compliance Office for review.
- 3.4 Minimum underlayment shall be in compliance with the applicable Roofing Applications Standards listed section 4.1 herein.
- 3.5 30/90 hot mopped underlayment applications may be installed perpendicular to the roof slope unless stated otherwise by the underlayment material manufacturers published literature.
- 3.6 This acceptance is for wood deck applications. Minimum deck requirements shall be in compliance with applicable building code.



## 4. INSTALLATION

### System A(1):

- Arguey 'S' Clay Roof Tile and its components shall be installed in strict compliance with Roofing Application Standard RAS 120.
- Data For Attachment Calculations

Table 1: Average Weight (W) and Dimensions (l x w)			
Tile Profile	Weight-W (lbf)	Length-l (ft)	Width-w (ft)
'S' Clay Roof Tile	8.7	1.5	0.92

Table 2: Aerodynamic Multipliers - $\lambda$ (ft <sup>3</sup> )	
Tile Profile	$\lambda$ (ft <sup>3</sup> ) Direct Deck Application
'S' Clay Roof Tile	0.273

Table 3: Restoring Moments due to Gravity - $M_g$ (ft-lbf)						
Tile Profile	2":12"	3":12"	4":12"	5":12"	6":12"	7":12"
'S' Clay Roof Tile	Direct Deck	Direct Deck	Direct Deck	Direct Deck	Direct Deck	Direct Deck
	6.63	6.57	6.45	6.28	6.04	5.73

Table 6: Attachment Resistance Expressed as a Moment $M_r$ (ft-lbf) for Two Paddy Adhesive Set Systems		
Tile Profile	Tile Application	Minimum Attachment Resistance
'S' Clay Roof Tile	Touch 'n Seal® StormBond™	13.7 <sup>1</sup>

1 Average weight per paddy; under the flange, "T" shaped paddy weighing 24.2 g, under the barrel section straight paddy weighing 22.9 grams (see details herein)

Table 7: Attachment Resistance Expressed as a Moment - $M_r$ (ft-lbf) for Single Paddy Adhesive Set Systems		
Tile Profile	Tile Application	Minimum Attachment Resistance
'S' Clay Roof Tile	ICP Adhesive Polyset® AH-160	66.5 <sup>2</sup>

2 Large paddy placement of 63 grams of ICP Adhesives and Sealants, Inc.'s ICP Adhesives Polyset AH-160.



**System A(2):**

1. Arguey ‘S’ Clay Roof Tile and its components shall be installed in strict compliance as noted below

**Deck Attachment:** In accordance with applicable Building Code, but in no case shall it be less than 8d annular ring shank nails spaced 6” o.c. In reroofing, where the deck is less than <sup>19</sup>/<sub>32</sub>” thick (Minimum <sup>15</sup>/<sub>32</sub>”). The above attachment method must be in addition to existing attachment.

**Underlayment:** One layer of Sharkskin Ultra® mechanically fastened to the deck with approved roofing nails and tin caps spaced 6” o.c. at the 4” horizontal overlap and 10” o.c. in a grid pattern having three equally spaced, staggered rows in the field of the sheet followed by one layer of Sharkskin Ultra SA®.

Sharkskin Ultra SA® shall be applied with a minimum 2” horizontal end lap and minimum 6” vertical overlaps. Back nail to deck with approved annular ring shank nails and tin caps at a maximum of 12” o.c. at the side laps and 6” o.c. at the end laps.

**Valleys, Rakes, Ridges, Eaves, Penetrations:** Shall be constructed in compliance with Roofing Application Standard RAS 120 and with ArteZanos®, Inc.’s published installation instructions.

2. Data For Attachment Calculations:

<b>Table 1: Average Weight (W) and Dimensions (l x w )</b>			
<b>Tile Profile</b>	<b>Weight-W (lbf)</b>	<b>Length-l (ft)</b>	<b>Width-w (ft)</b>
‘S’ Clay Roof Tile	8.7	1.5	0.92

<b>Table 2: Aerodynamic Multipliers - λ (ft<sup>3</sup>)</b>	
<b>Tile Profile</b>	<b>λ (ft<sup>3</sup>) Direct Deck Application</b>
‘S’ Clay Roof Tile	0.25

<b>Table 3: Restoring Moments due to Gravity - M<sub>g</sub> (ft-lbf)</b>						
<b>Tile Profile</b>	<b>2":12"</b>	<b>3":12"</b>	<b>4":12"</b>	<b>5":12"</b>	<b>6":12"</b>	<b>7":12"</b>
‘S’ Clay Roof Tile	Direct Deck	Direct Deck	Direct Deck	Direct Deck	Direct Deck	Direct Deck
	6.78	6.69	6.56	6.40	6.21	6.01

<b>Table 6: Attachment Resistance Expressed as a Moment M<sub>r</sub> (ft-lbf) for Two Paddy Adhesive Set Systems</b>		
<b>Tile Profile</b>	<b>Tile Application</b>	<b>Minimum Attachment Resistance</b>
‘S’ Clay Roof Tile	Touch ‘n Seal® StormBond™	59.36 <sup>3</sup>

3 Average weight per paddy; under the flange, “T” shaped paddy weighing 24.5 g, under the barrel section 42.9 grams (see details herein)



## 5. LABELING

All tiles shall bear the imprint or identifiable marking of the manufacturer's name or logo (See Detail Below), or following statement: "Miami-Dade County Product Control Approved".



**IDENTIFICATION MARK FOR ARGUEY "S" CLAY TILE  
(LOCATED ON FLANGE OF TILE - TOPSIDE)**

## 6. BUILDING PERMIT REQUIREMENTS

**6.1** Application for building permit shall be accompanied by copies of the following:

**6.1.1** This Notice of Acceptance.

**6.1.2** Any other documents required by the Building Official or applicable building code in order to properly evaluate the installation of this system.



NOA No.: 23-1025.05  
Expiration Date: 12/14/28  
Approval Date: 12/21/23  
Page 6 of 8

**PROFILE DRAWINGS**

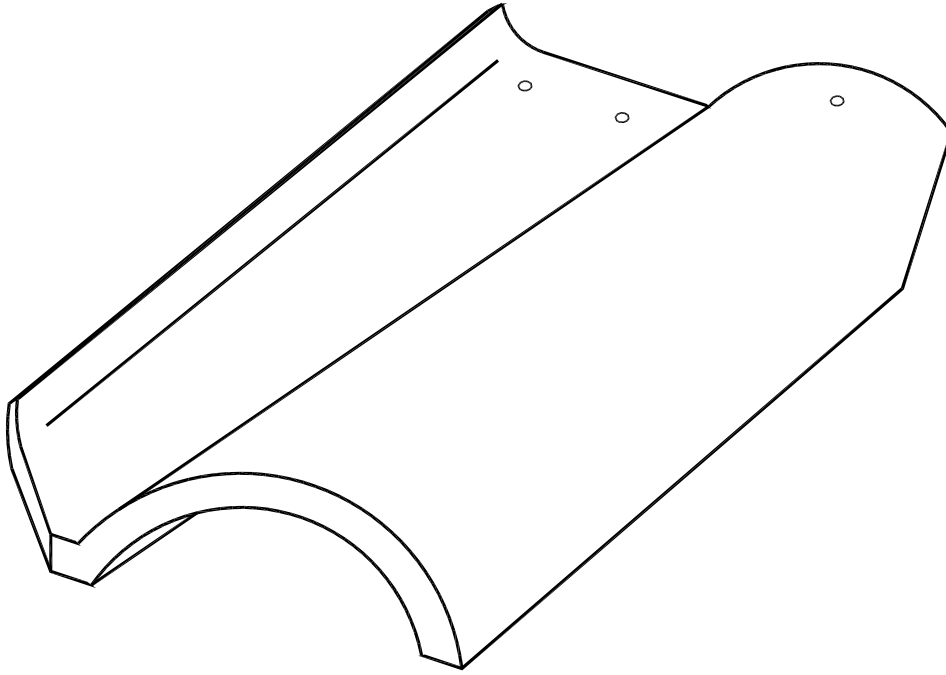

**'S' CLAY ROOF TILE  
(DRAWING NOT TO SCALE)**

# DETAIL A

## TWO PADDY PLACEMENT DETAIL FOR TOUCH N' SEAL® STORMBOND™ (DRAWINGS NOT TO SCALE)

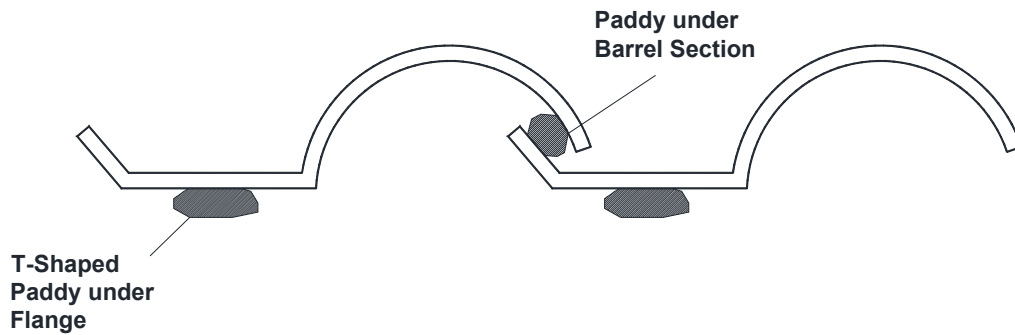
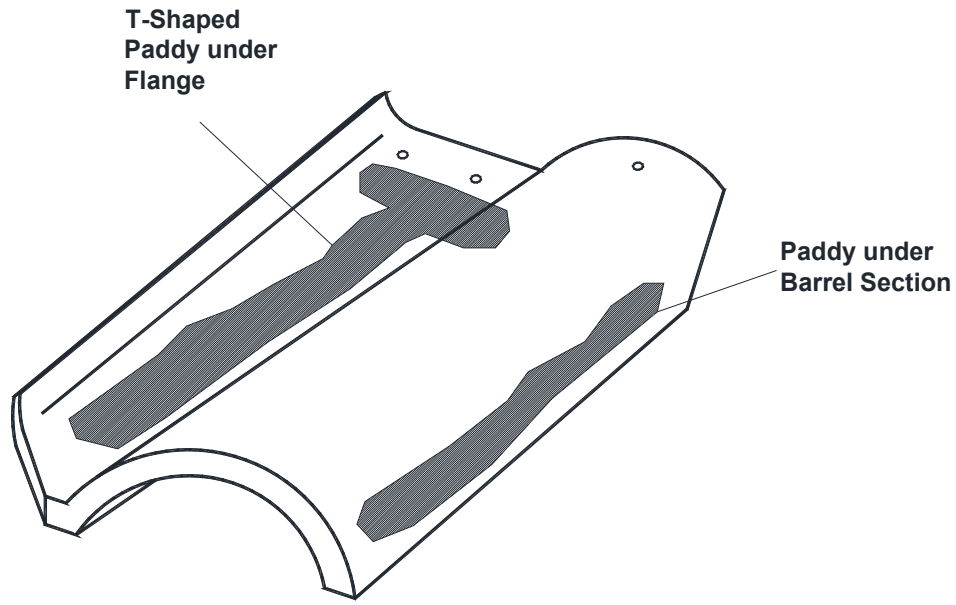

**END OF THIS ACCEPTANCE**



NOA No.: 23-1025.05  
Expiration Date: 12/14/28  
Approval Date: 12/21/23  
Page 8 of 8