



DEPARTMENT OF REGULATORY AND ECONOMIC RESOURCES (RER)
BOARD AND CODE ADMINISTRATION DIVISION

NOTICE OF ACCEPTANCE (NOA)

MIAMI-DADE COUNTY
PRODUCT CONTROL SECTION
11805 SW 26 Street, Room 208
Miami, Florida 33175-2474
T (786) 315-2590 F (786) 315-2599
www.miamidade.gov/economy

Unirac, Inc.
1411 Broadway Blvd. NE
Albuquerque, NM 87102

SCOPE:

This NOA is being issued under the applicable rules and regulations governing the use of construction materials. The documentation submitted has been reviewed and accepted by Miami-Dade County RER-Product Control Section to be used in Miami-Dade County and other areas where allowed by the Authority Having Jurisdiction (AHJ).

This NOA shall not be valid after the expiration date stated below. The Miami-Dade County Product Control Section (In Miami-Dade County) and/ or the AHJ (in areas other than Miami-Dade County) reserve the right to have this product or material tested for quality assurance purposes. If this product or material fails to perform in the accepted manner, the manufacturer will incur the expense of such testing and the AHJ may immediately revoke, modify, or suspend the use of such product or material within their jurisdiction. RER reserves the right to revoke this acceptance if it is determined by Miami-Dade County Product Control Section that this product or material fails to meet the requirements of the applicable building code.

This product is approved as described herein and has been designed to comply with the Florida Building Code, including the High Velocity Hurricane Zone.

DESCRIPTION: FlashLoc Comp and FlashLoc Duo Aluminum Solar Mounts

APPROVAL DOCUMENT: Drawing titled "FlashLoc Comp and FlashLoc Duo Solar Mounts", sheets 1 through 6 of 6, prepared by Unirac, Inc, dated on 04/05/2022, signed and sealed by Paul K. Zacher, P.E. on 02/05/2024, bearing the Miami-Dade County Product Control revision stamp with the Notice of Acceptance number and expiration date by the Miami-Dade County Product Control Section.

MISSILE IMPACT RATING: None

LABELING: Each box shall bear a permanent label with the manufacturer's name or logo, city, state and following statement: "Miami-Dade County Product Control Approved or MDCPCA", unless otherwise noted herein.

RENEWAL of this NOA shall be considered after a renewal application has been filed and there has been no change in the applicable building code negatively affecting the performance of this product.

TERMINATION of this NOA will occur after the expiration date or if there has been a revision or change in the materials, use, and/or manufacture of the product or process. Misuse of this NOA as an endorsement of any product, for sales, advertising or any other purposes shall automatically terminate this NOA. Failure to comply with any section of this NOA shall be cause for termination and removal of NOA.

ADVERTISEMENT: The NOA number preceded by the words Miami-Dade County, Florida, and followed by the expiration date may be displayed in advertising literature. If any portion of the NOA is displayed, then it shall be done in its entirety.

INSPECTION: A copy of this entire NOA shall be provided to the user by the manufacturer or its distributors and shall be available for inspection at the job site at the request of the Building Official.

This NOA **revises NOA # 22-0516.03** and consists of this page 1, evidence page E-1, as well as approval document mentioned above.

The submitted documentation was reviewed by **Carlos M. Utrera, P.E.**

03/18/24



NOA No: 24-0208.05
Expiration Date: July 18, 2027
Approval Date: March 28, 2024
Page 1

NOTICE OF ACCEPTANCE: EVIDENCE SUBMITTED

1. **Evidence submitted under NOA # 22-0516.03 and new**

A. DRAWINGS

1. Drawing titled “FlashLoc Comp and FlashLoc Duo Solar Mounts”, sheets 1 through 6 of 6, prepared by Unirac, Inc, dated 04/05/2022, signed and sealed by Paul K. Zacher, P.E. on 02/05/2024.

B. TESTS

1. Test report on Uplift and Shear Allowable Loads of the FlashLock Comp Solar Mount per ASTM D7147-11, prepared by Intertek, Test Report No. **M4861.01-119-18 R0**, dated 09/15/2021, signed and sealed by Vinu J. Abraham, P.E.
2. Test report on Uplift and Shear Allowable Loads of the FlashLoc Duo Solar Mount per ASTM D7147-11, prepared by Intertek, Test Report No. **M7466.01-119-18 R0**, dated 09/15/2021, signed and sealed by Vinu J. Abraham, P.E.
3. Test report on Wind Driven Rain Resistance of the FlashLock Comp Solar Mount per TAS 100(A)-95, prepared by Intertek, Test Report No. **K1186.01-109-18**, dated 09/24/2019, signed and sealed by Daniel C. Culbert, P.E.
4. Test report on Wind Driven Rain Resistance of the FlashLoc Duo Solar Mount per TAS 100(A)-95, prepared by Intertek, Test Report No. **M3331.01-109-18**, dated 06/07/2021, signed and sealed by Daniel C. Culbert, P.E.

C. CALCULATIONS

1. Anchor calculations prepared by PZ Structural Engineers, dated 11/03/2021, signed and sealed by Paul K. Zacher, P.E.

D. MATERIAL CERTIFICATIONS

1. None.

E. QUALITY ASSURANCE

1. Miami-Dade Department of Regulatory and Economic Resources (RER).

F. STATEMENTS

1. Statement letter of code conformance to the 8th edition (2023) of the FBC, issued by PZ Structural Engineers, dated 02/05/2024, signed and sealed by Paul K. Zacher, P.E.
2. Statement letter of code conformance to the 7th edition (2020) of the FBC issued by PZ Structural Engineers, dated 11/03/2021, signed and sealed by Paul K. Zacher, P.E.
3. Statement letter of no financial interest issued by PZ Structural Engineers, dated 11/03/2021, signed and sealed by Paul K. Zacher, P.E.



Carlos M. Utrera, P.E.
Product Control Examiner
NOA No: 24-0208.05
Expiration Date: July 18, 2027
Approval Date: March 28, 2024

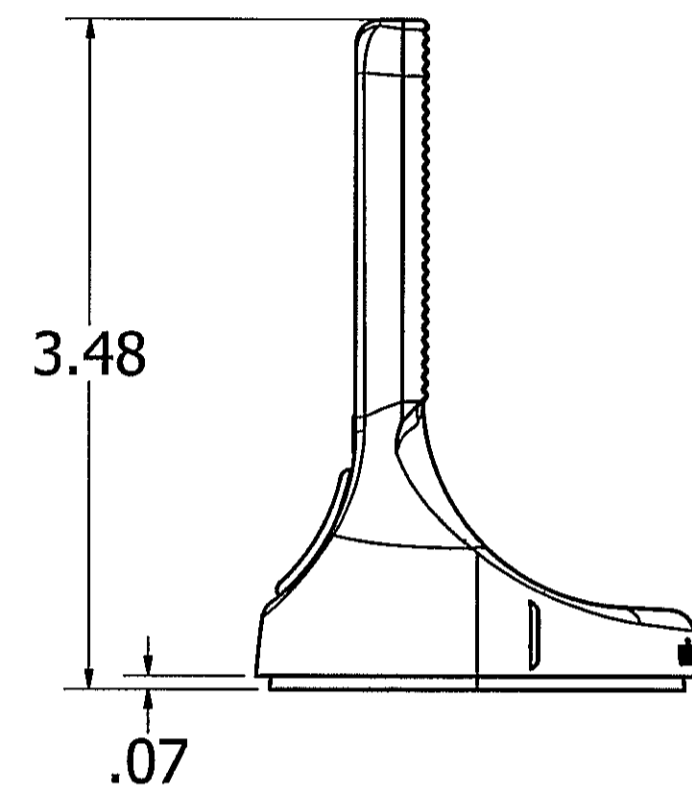
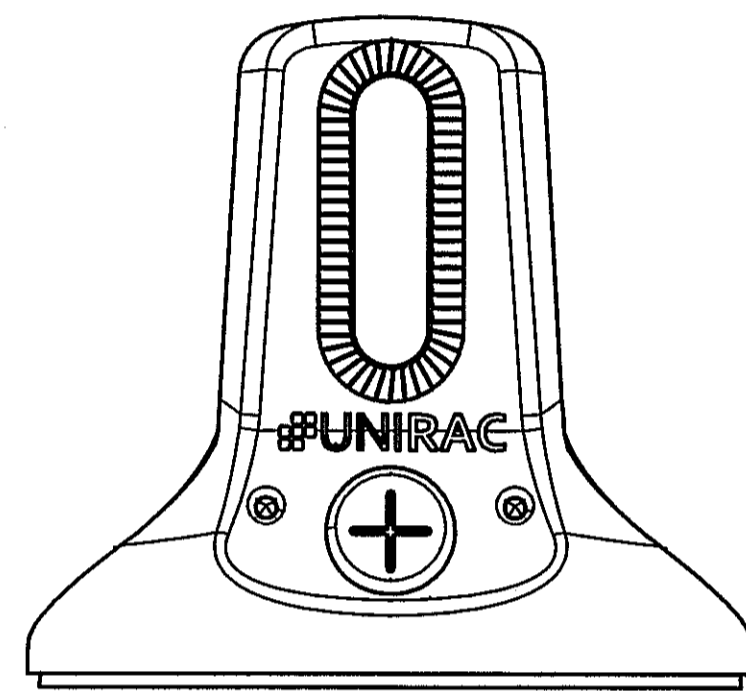
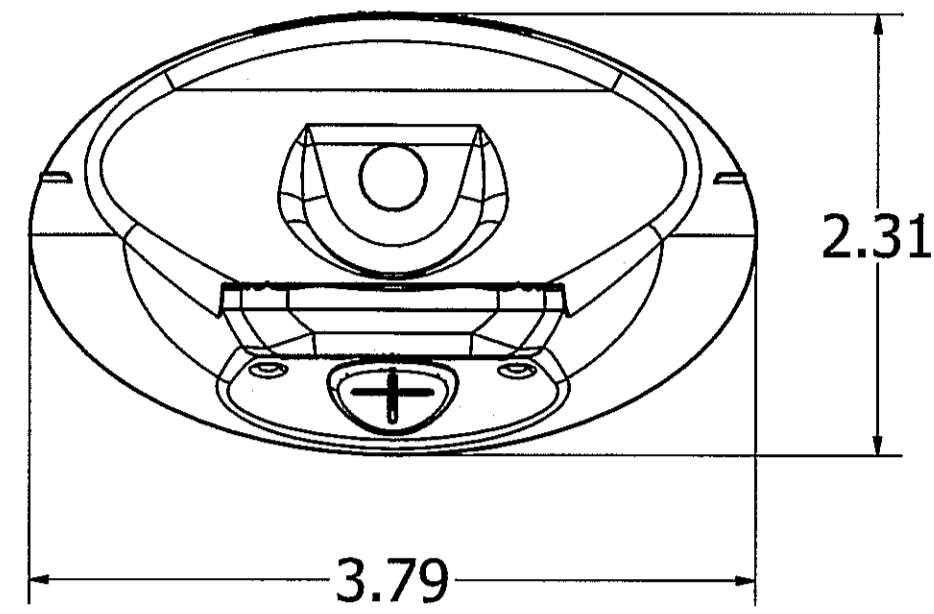

COMP BASE ASSEMBLY

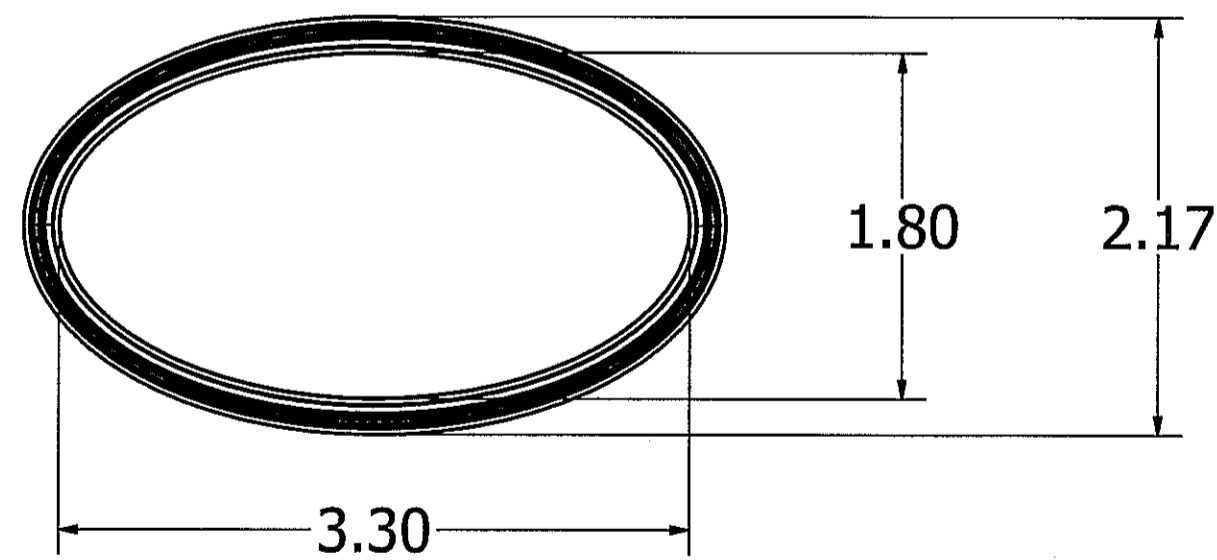
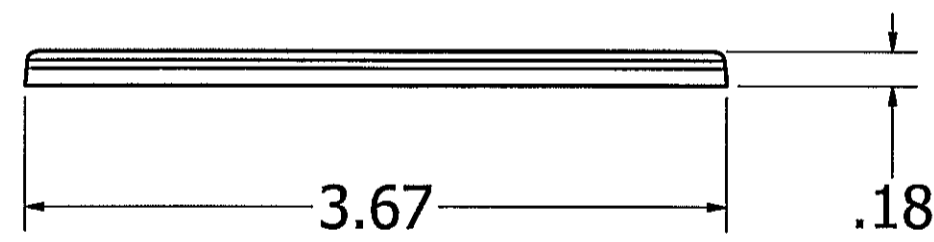

COMP BASE SEAL

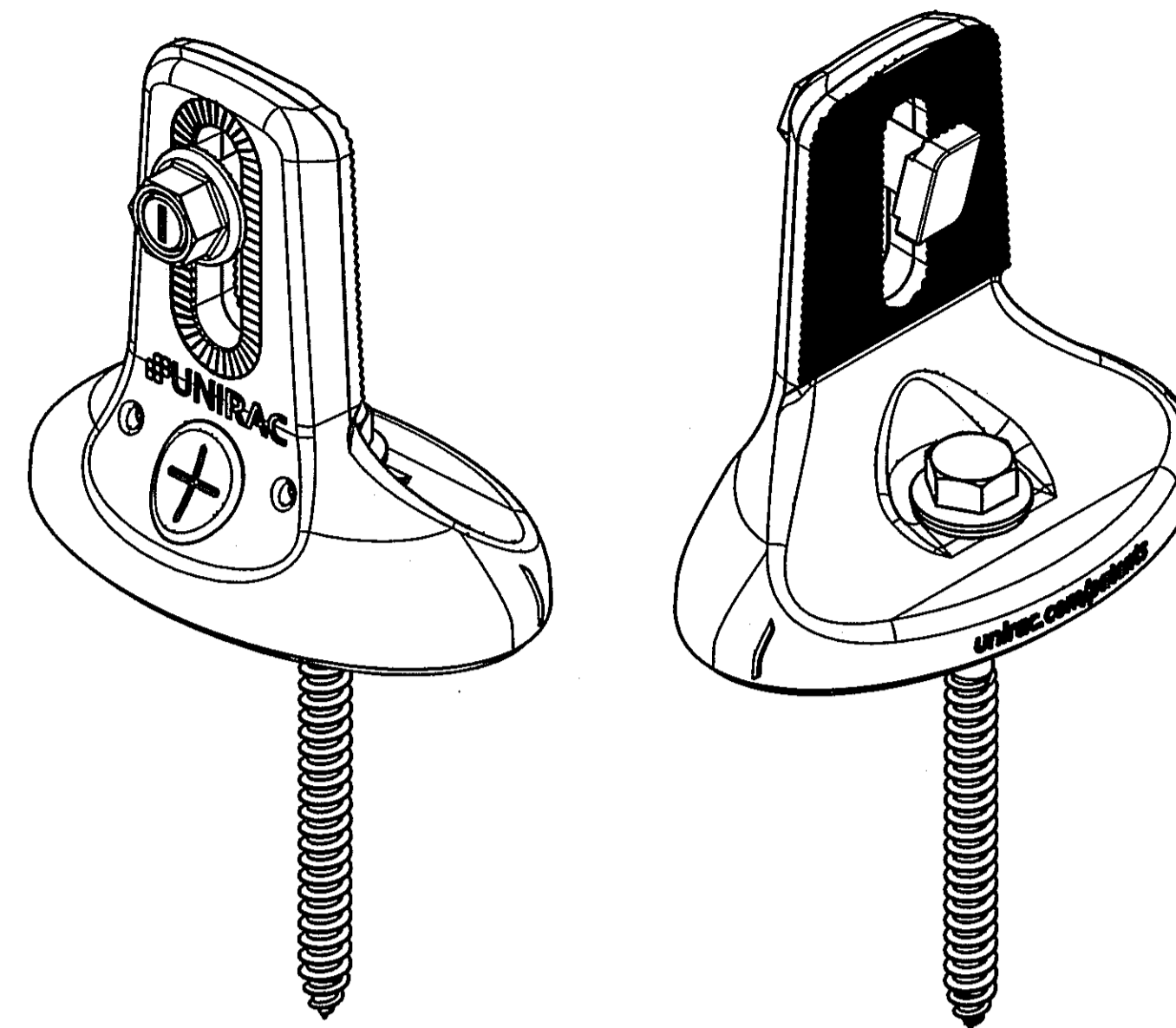

FLASHLOC COMP ASSEMBLY

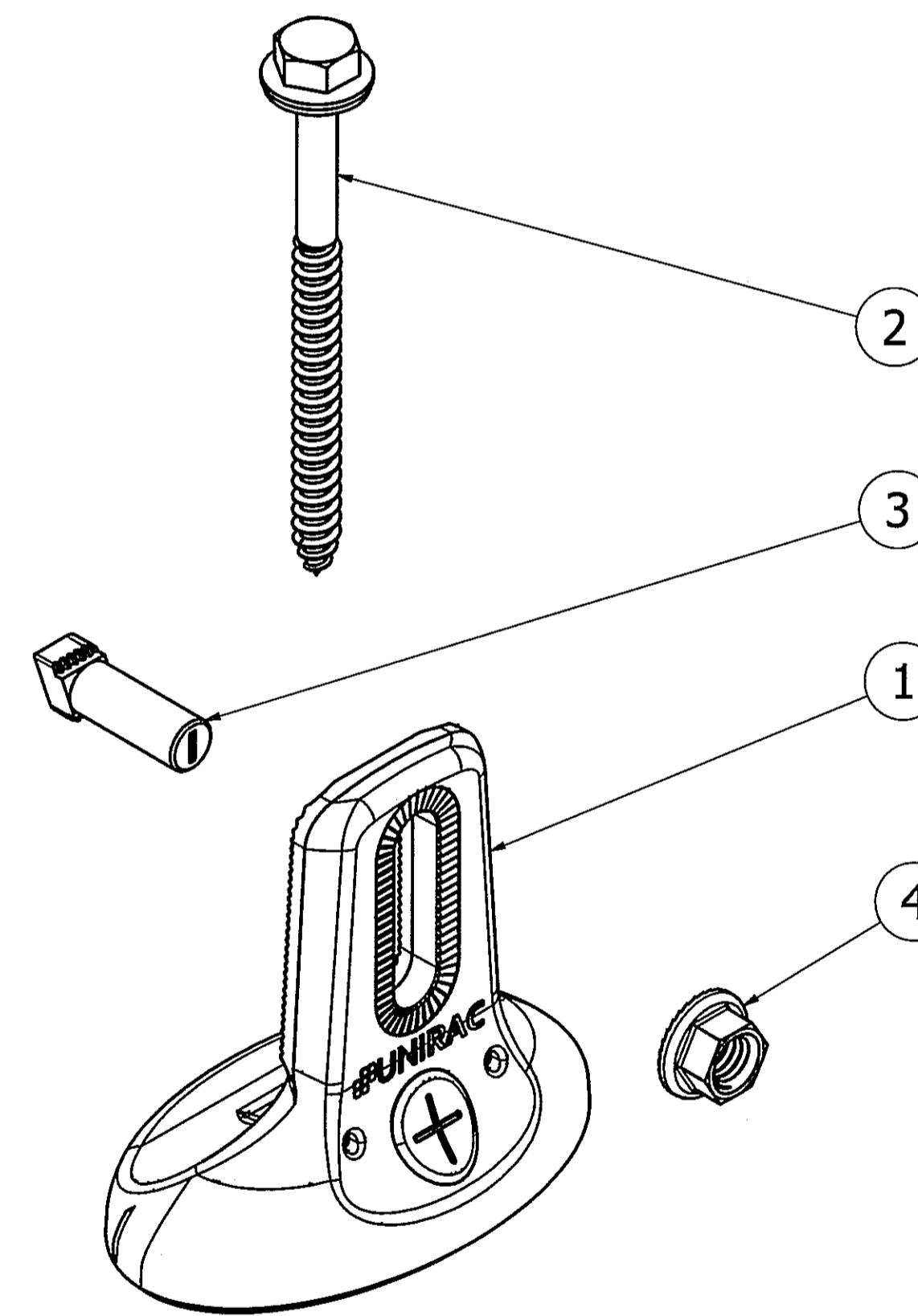

EXPLODED VIEW

PRODUCT REVISED
as complying with the Florida
Building Code
NOA-No. 24-0208.05
Expiration Date 07/18/2027
By *[Signature]*
Miami-Dade Product Control

ASSEMBLY NUMBER - NAME	ITEM #	DESCRIPTION	MATERIAL	MINIMUM YIELD (KSI)	MINIMUM ULTIMATE (KSI)
004085M (MILL), 004085D (DARK) - FLASHLOC COMP KIT	1	FLASHLOC COMP ASSEMBLY	CAST ALUMINUM A380	23	47
	2	SH LAG BOLT	18/8 STAINLESS STEEL	N/A	85
	3	TBOLT, SERR, .38-16 SS PASS	300 SERIES STAINLESS STEEL	N/A	70
	4	NUT, SERR FLG 1/2" HEX 3/8-16	300 SERIES 18-8 STAINLESS STEEL	N/A	85

PE STAMP:

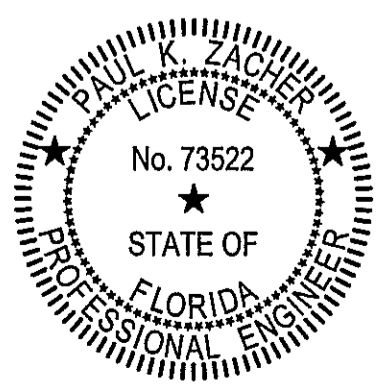

2023 FLORIDA BUILDING CODE, 8TH EDITION ASCE 7-22

PE SIGNATURE:

PE DATE:

02/05/2024

REVISIONS	REVIDATE	DESCRIPTION	CHK
1	4/05/22	INITIAL RELEASE	-

FOR
MIAMI-DADE
COUNTY

PROJECT
MIAMI-DADE CO.
NOA

PROJECT ADDRESS

TITLE

DWG NO.

SHEET 1 OF 6

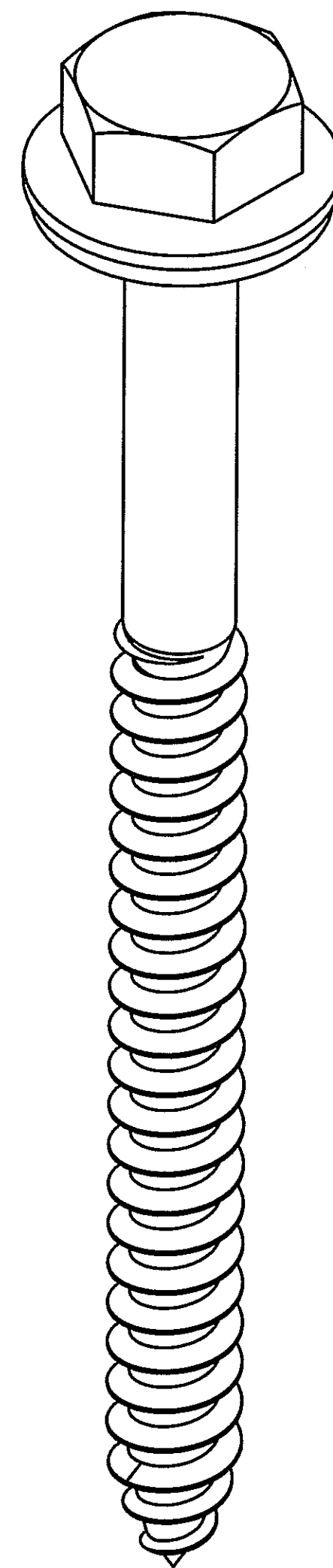
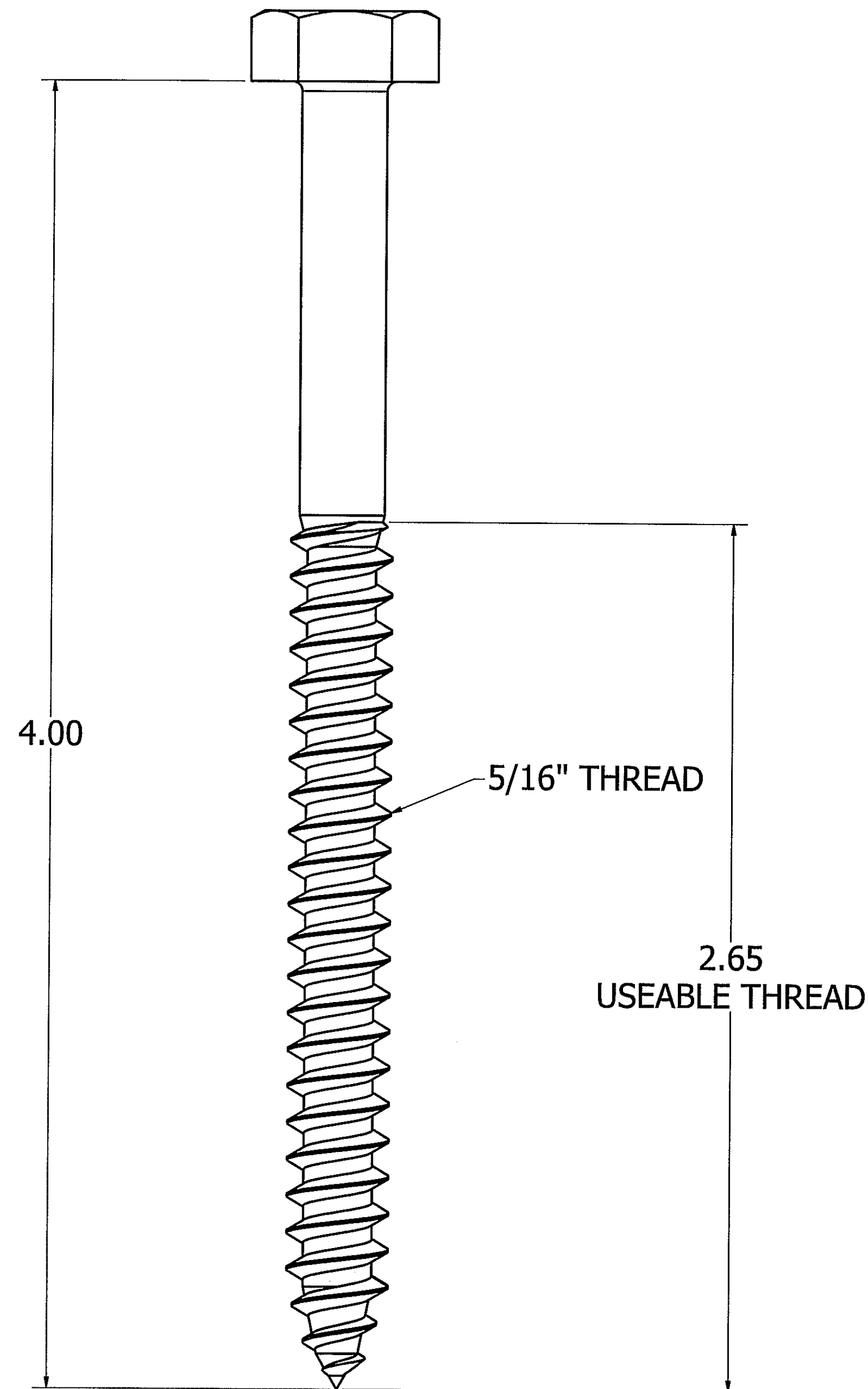
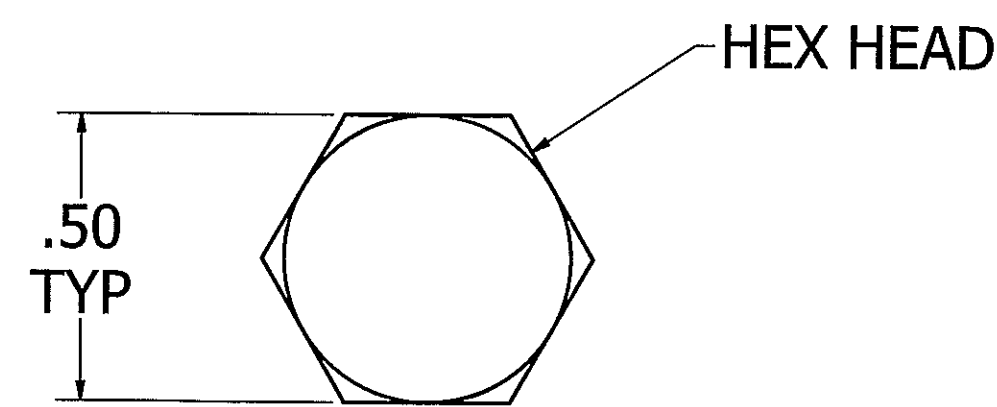

SH LAG SCREW

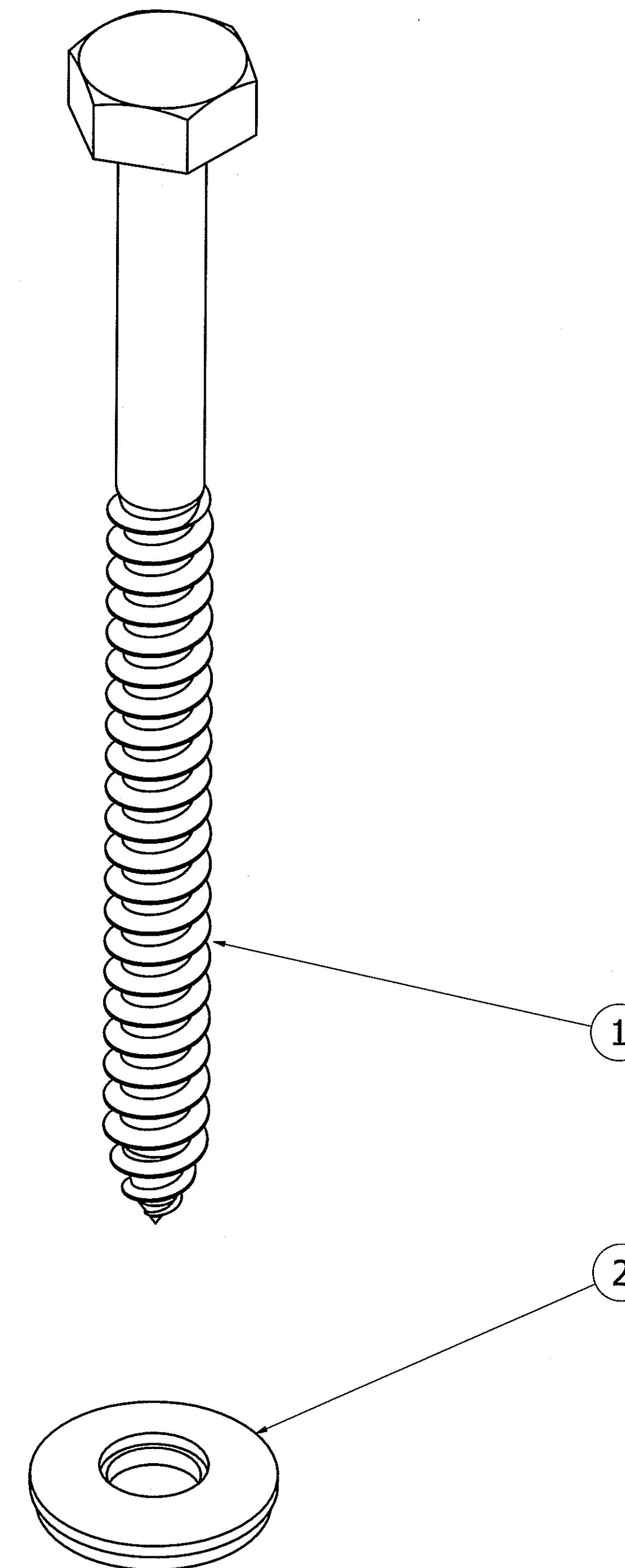

PE STAMP:

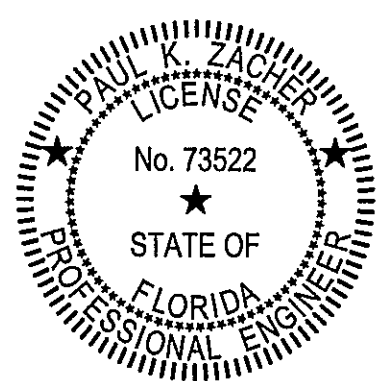

2023 FLORIDA BUILDING CODE, 8TH EDITION ASCE 7-22

PE SIGNATURE:

PE DATE:

02/05/2024

PRODUCT REVISED
as complying with the Florida
Building Code
NOA-No. 24-0208.05
Expiration Date 07/18/2027
By *[Signature]*
Miami-Dade Product Control

PARTS LIST

ITEM	QTY	PART NUMBER	DESCRIPTION
1	1	M31150	5/16 X 4.00 HEX HEAD LAG SCREW, SS
2	1	M30062	5/16 EPDM WASHER SS

REV	DATE	DESCRIPTION	CHK
1	4/05/22	INITIAL RELEASE	-

FOR
MIAMI-DADE
COUNTY

PROJECT
MIAMI-DADE CO.
NOA

PROJECT ADDRESS

TITLE

DWG NO.
SHEET 2 OF 6

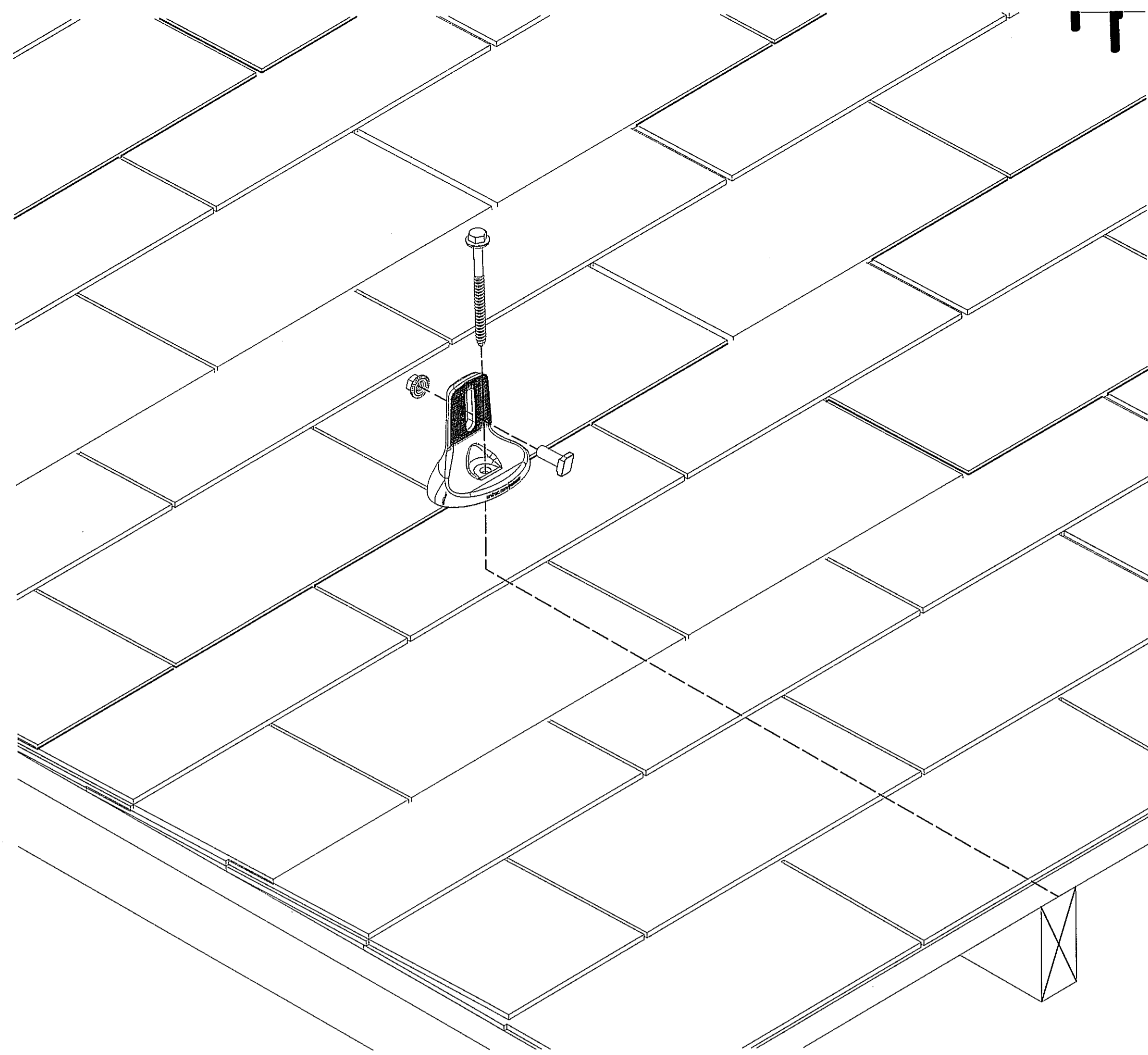

SOLARMOUNT FLASHLOC COMP INSTALLATION
NOT TO SCALE

STRUCTURAL MEMBER SPECIFICATION:

MINIMUM WOOD GRADE = SPF #2
MINIMUM SPECIFIC GRAVITY = 0.42

ALLOWABLE FASTENER UPLIFT = 517.3 lbs
ALLOWABLE FASTENER LATERAL = 167 lbs

MINIMUM FASTENER EDGE DISTANCE = 0.5"
MINIMUM FASTENER END DISTANCE = 2.2"

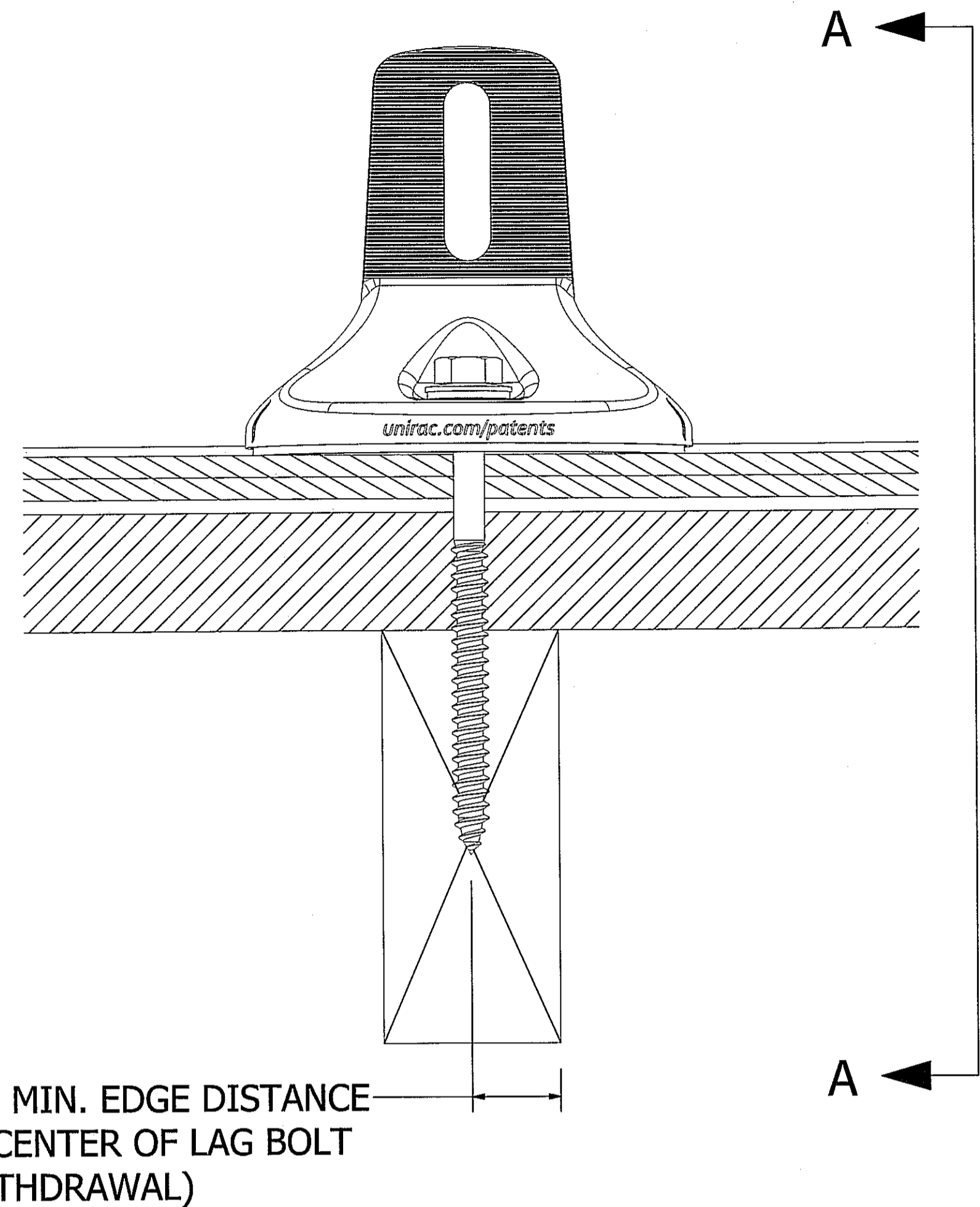

3/4" MIN. EDGE DISTANCE
TO CENTER OF LAG BOLT
(WITHDRAWAL)

SECTION FLASHLOC COMP DETAIL
NOT TO SCALE

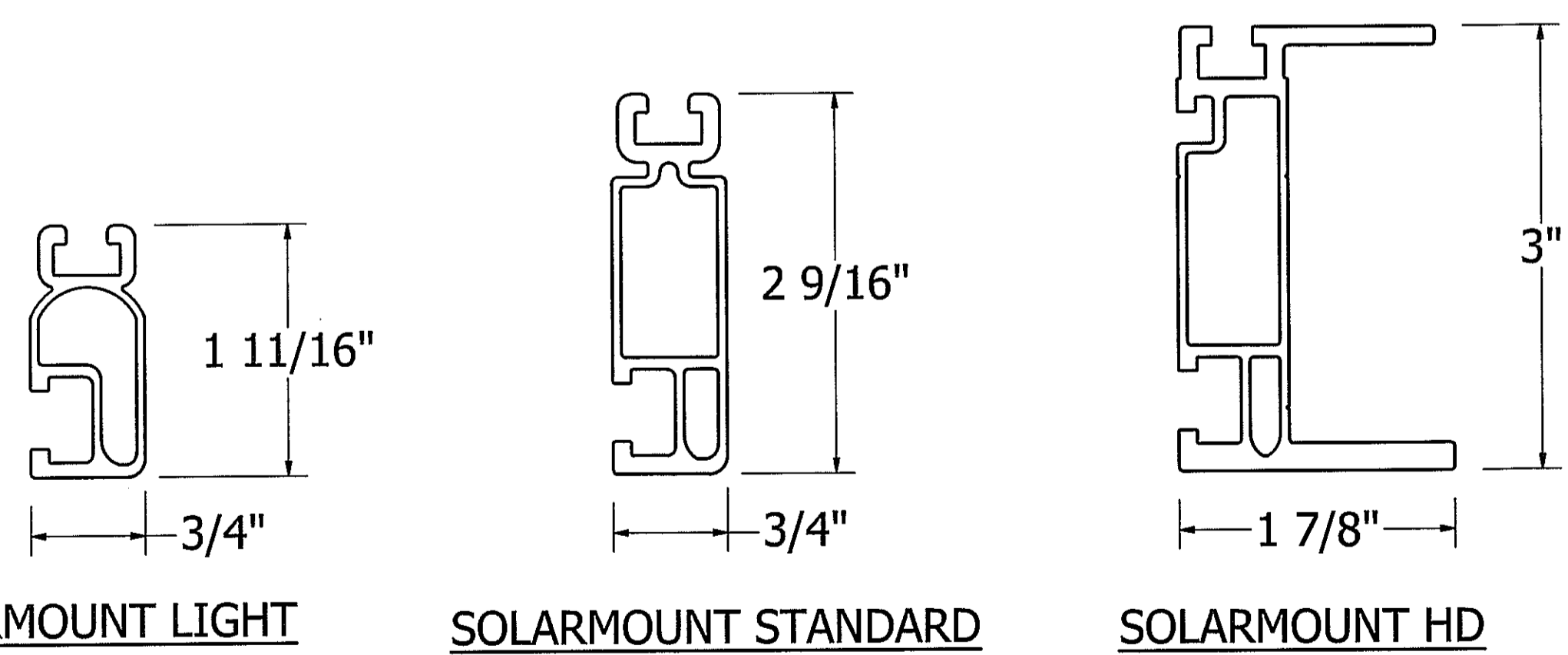

SOLARMOUNT LIGHT

SOLARMOUNT STANDARD

SOLARMOUNT HD

PRODUCT REVISED
as complying with the Florida
Building Code
NOA-No. 24-0208.05
Expiration Date 07/18/2027
By Miami-Dade Product Control

ROOF DECK
(STANDARD ROOF CONSTRUCTION)

5/16" STAINLESS STEEL LAG BOLT
WITH 3 1/2" MIN. EMBEDMENT AND
(SS / EPDM) FLAT WASHER

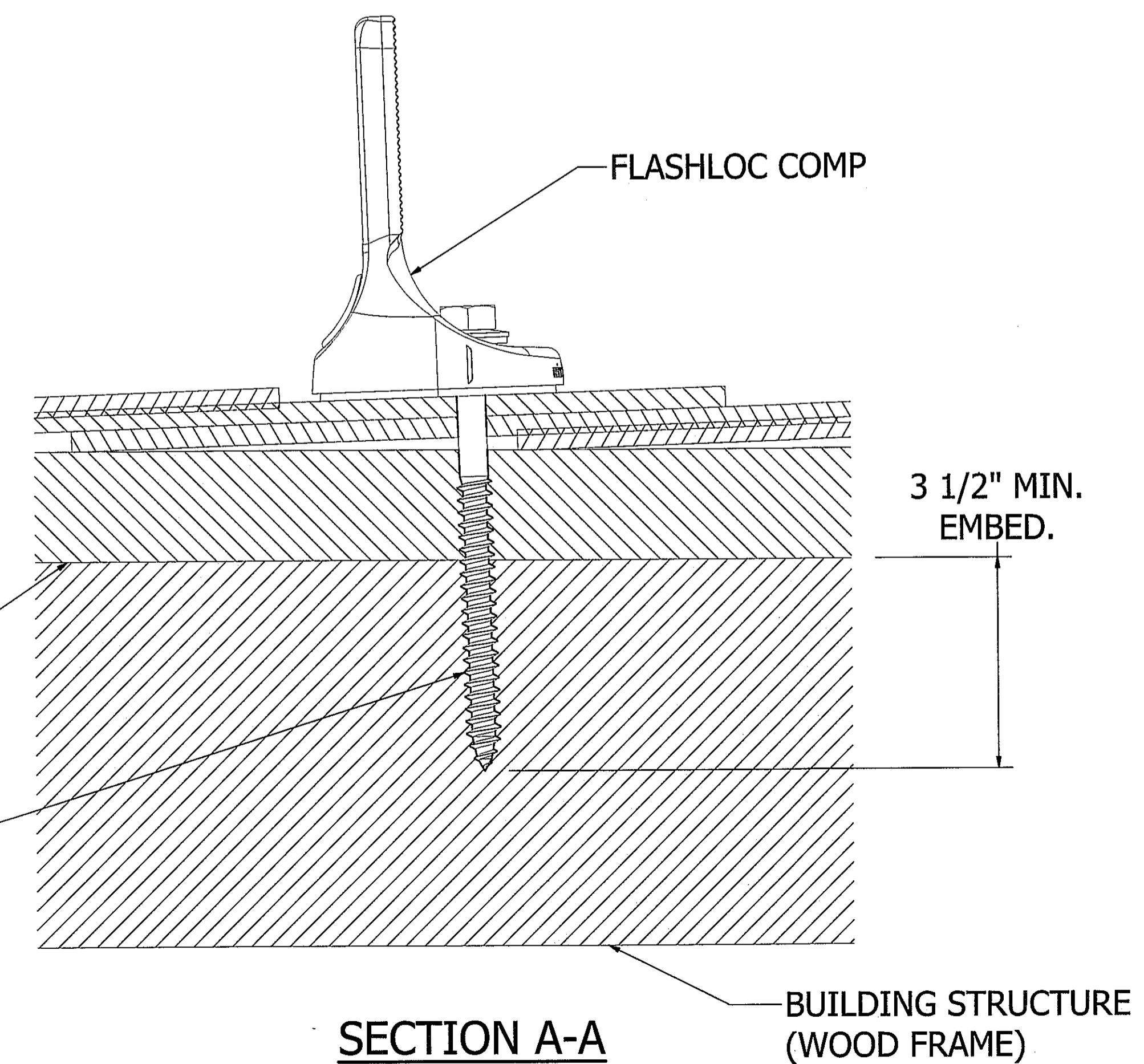

3 1/2" MIN.
EMBED.

SECTION A-A
NOT TO SCALE

BUILDING STRUCTURE
(WOOD FRAME)

UNIRAC
1411 BROADWAY BOULEVARD NE
ALBUQUERQUE, NM, USA, 87102
WWW.UNIRAC.COM

REV DATE	DESCRIPTION	CHK
1 4/05/22	INITIAL RELEASE	-

FOR
MIAMI-DADE
COUNTY

PROJECT
MIAMI-DADE CO.
NOA

PROJECT ADDRESS

TITLE
SOLARMOUNT
SYSTEM
DETAILS

DWG NO.
M-D NOA
SHEET 3 OF 6

PE STAMP:

2023 FLORIDA BUILDING CODE, 8TH EDITION ASCE 7-22
PE SIGNATURE: PE DATE:
02/05/2024

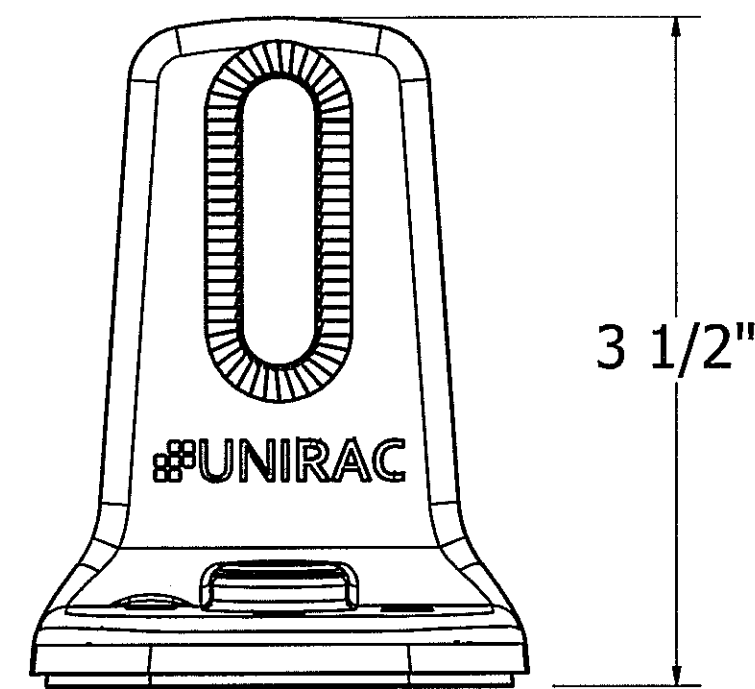
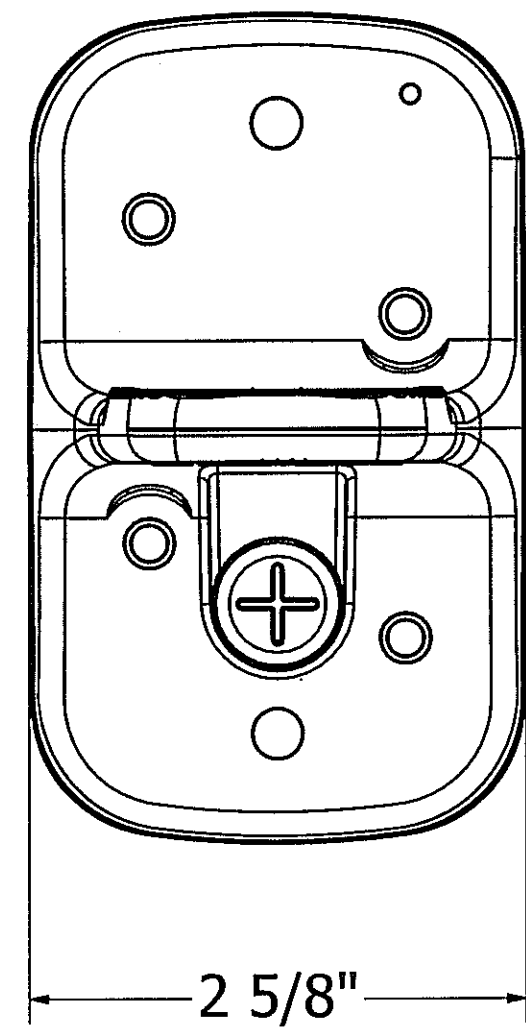

FLASHLOC DUO ASSEMBLY

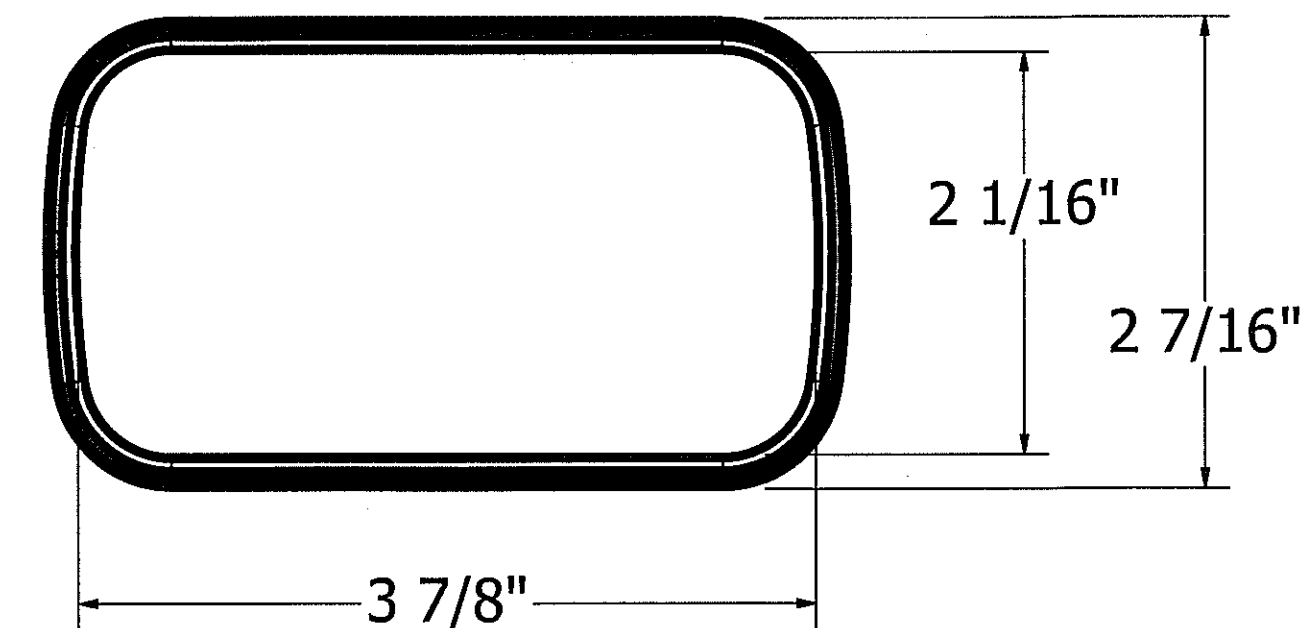
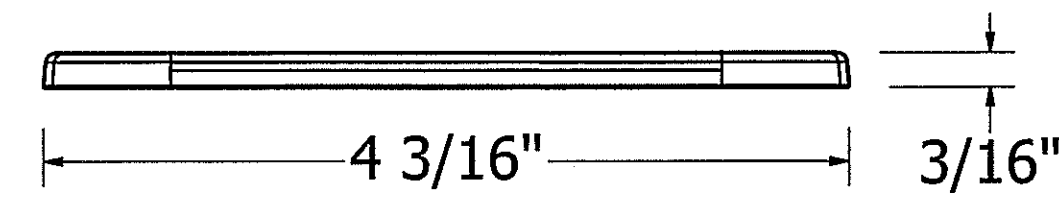
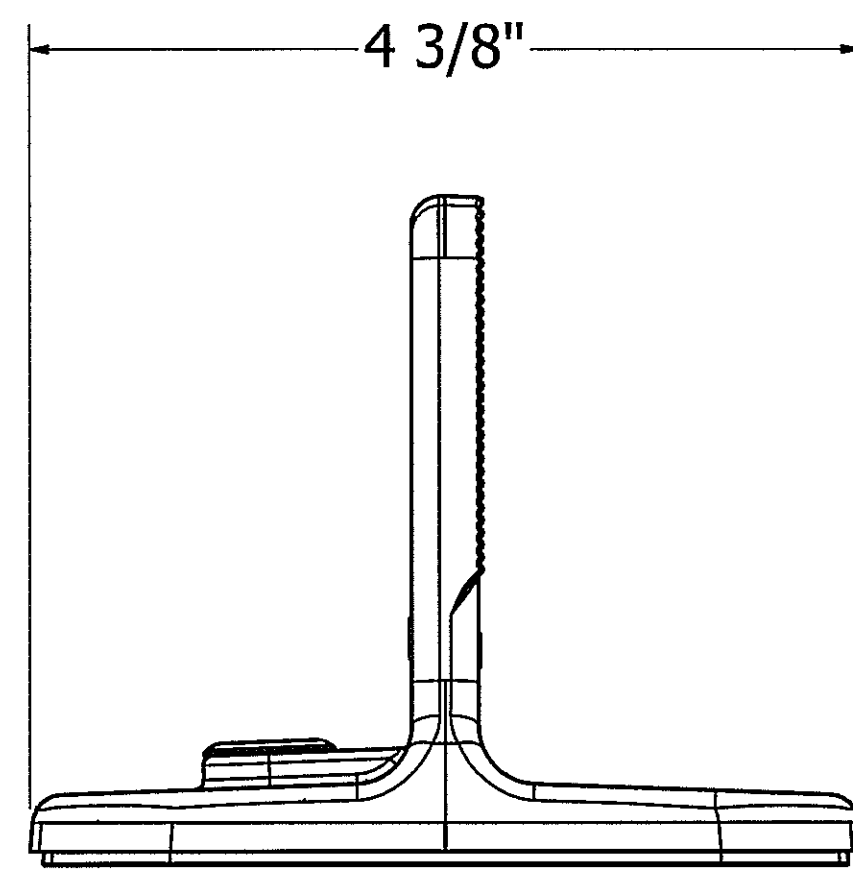

FLASHLOC DUO SEAL

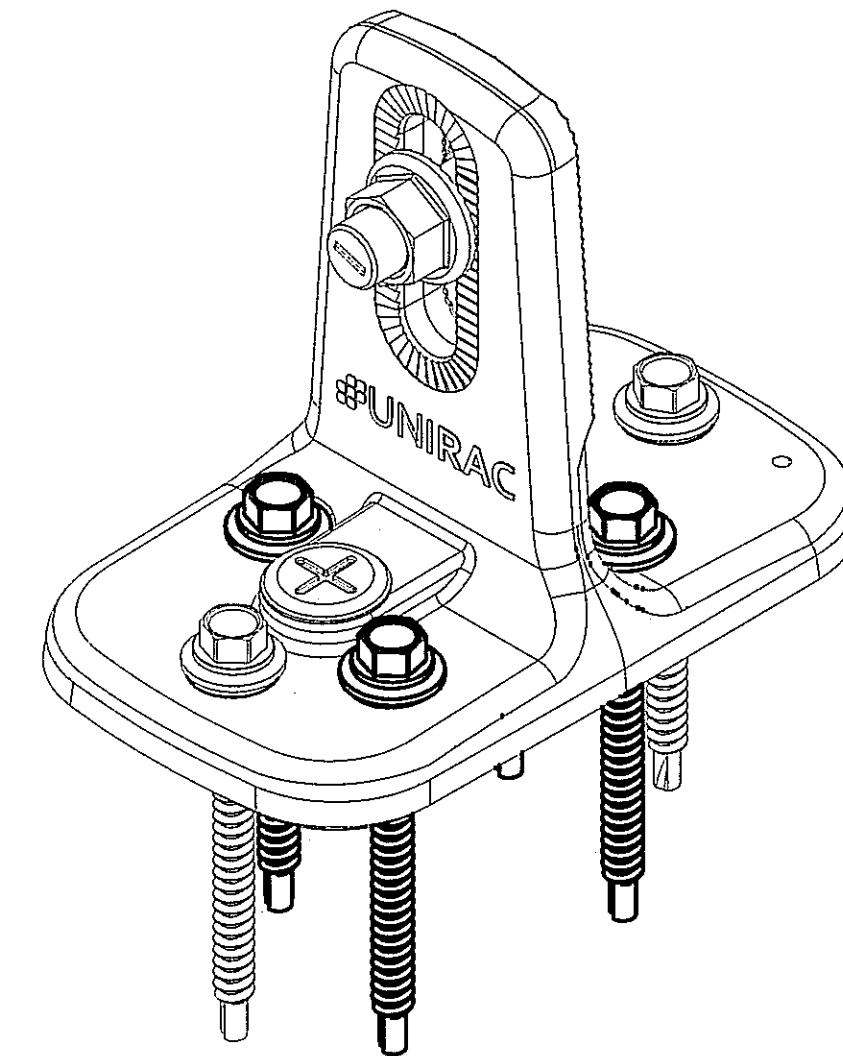

FLASHLOC DUO ASSEMBLY WITH ADDITIONAL SCREWS

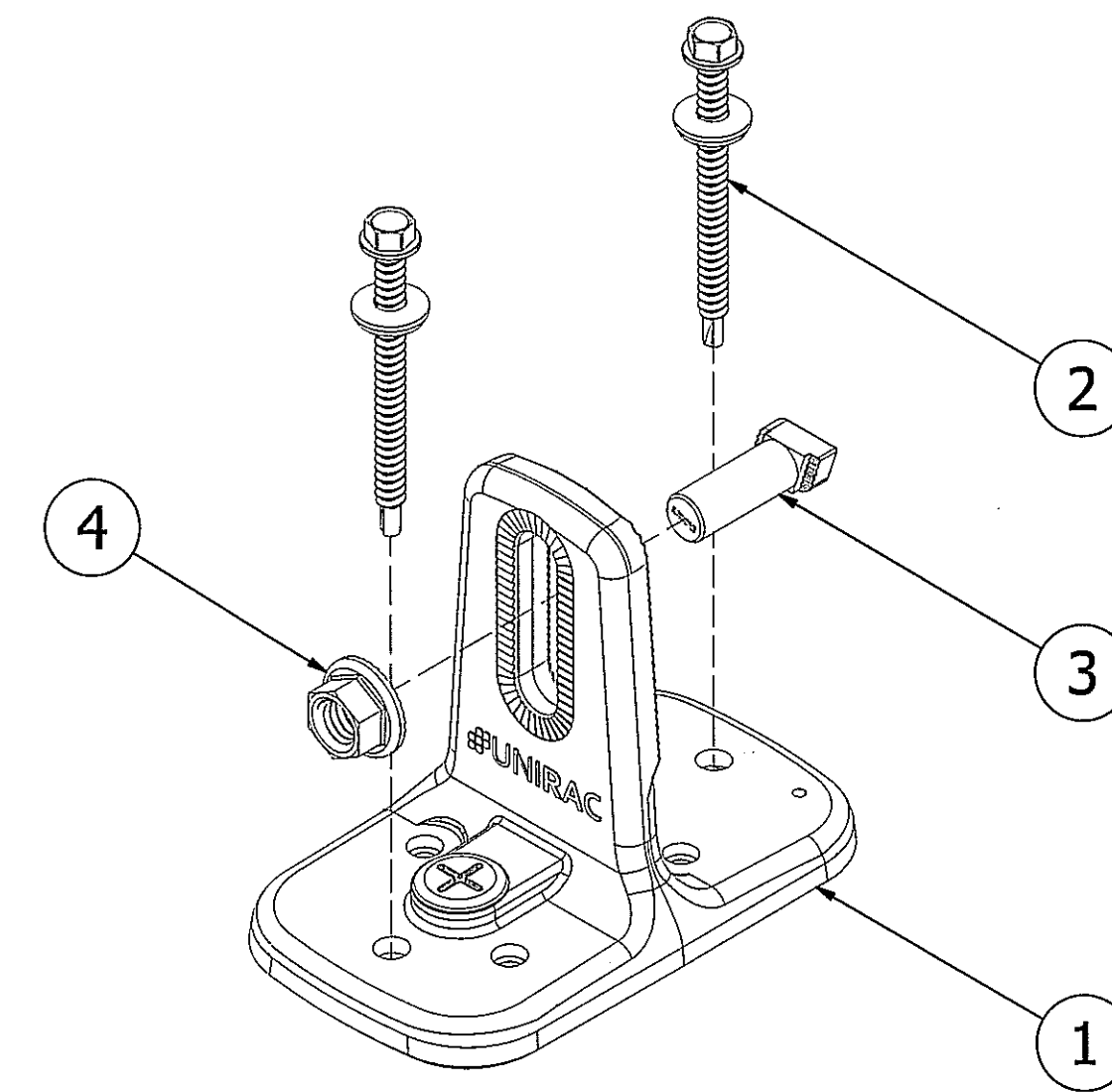

PRODUCT REVISED
 as complying with the Florida Building Code
 NOA-No. 24-0208.05
 Expiration Date 07/18/2027
 By *[Signature]*
 Miami-Dade Product Control

ASSEMBLY NUMBER - NAME	ITEM #	DESCRIPTION	MATERIAL	MINIMUM YIELD (KSI)	MINIMUM ULTIMATE (KSI)
004275M, 004275D - FLASHLOC DUO	1	FLASHLOC DUO ASSEMBLY	CAST ALUMINUM A380	23	47
	2	HEX HEAD EPDM ASSEMBLY, 2.5"	304 SS OR OTHER 18-8 SS AS APPROVED BY UNIRAC	N/A	70
	3	BOLT, ENHCD T 3/8-16X1.0 SS	300 SERIES STAINLESS STEEL	N/A	70
	4	NUT, SERR FLG 1/2" HEX 3/8-16	300 SERIES 18-8 STAINLESS STEEL	N/A	85

PE STAMP:

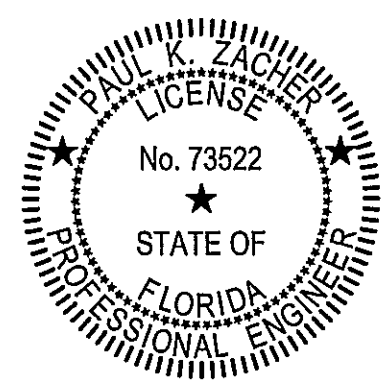

2023 FLORIDA BUILDING CODE, 8TH EDITION ASCE 7-22

PE SIGNATURE:

PE DATE:

02/05/2024

UNIRAC
 1411 BROADWAY BOULEVARD NE
 ALBUQUERQUE, NM, USA, 87102
 WWW.UNIRAC.COM

REVISIONS	CHK
REV DATE	DESCRIPTION
1 4/05/22	INITIAL RELEASE

FOR
 MIAMI-DADE COUNTY

PROJECT
 MIAMI-DADE CO. NOA

PROJECT ADDRESS

TITLE
 SOLARMOUNT SYSTEM DETAILS

DWG NO.
 M-D NOA
 SHEET 4 OF 6

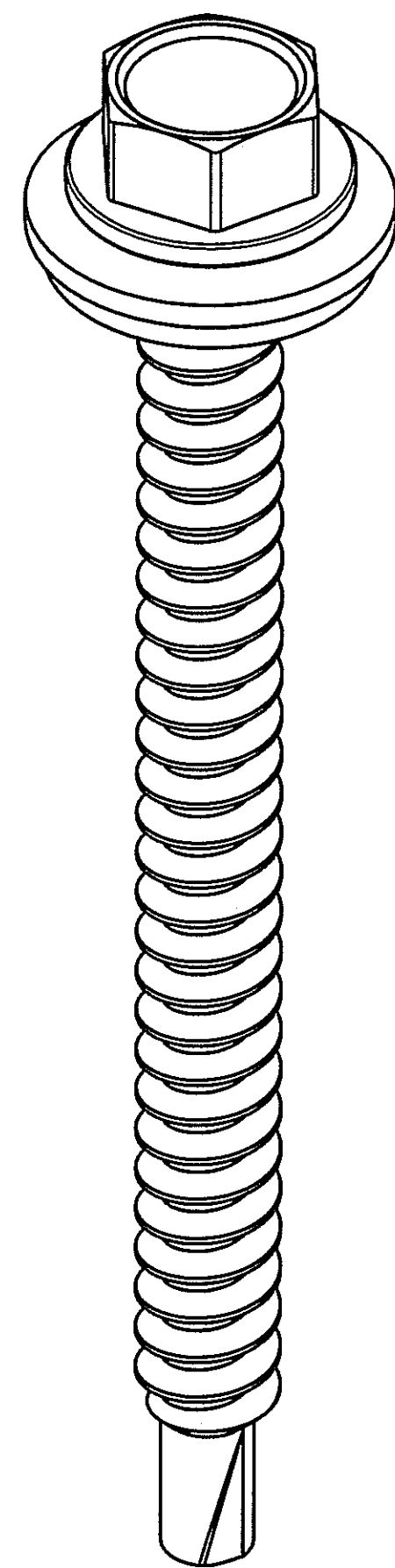
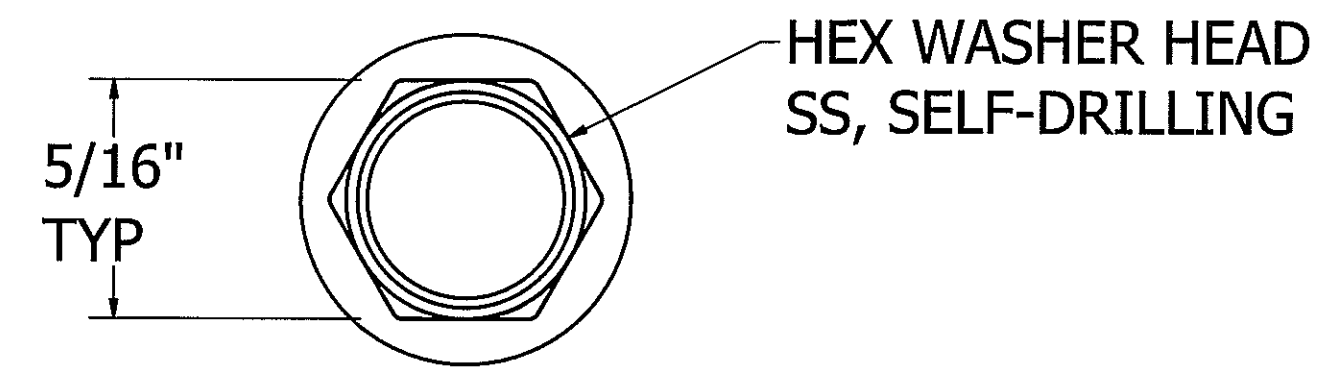

DUO SCREW ASSEMBLY

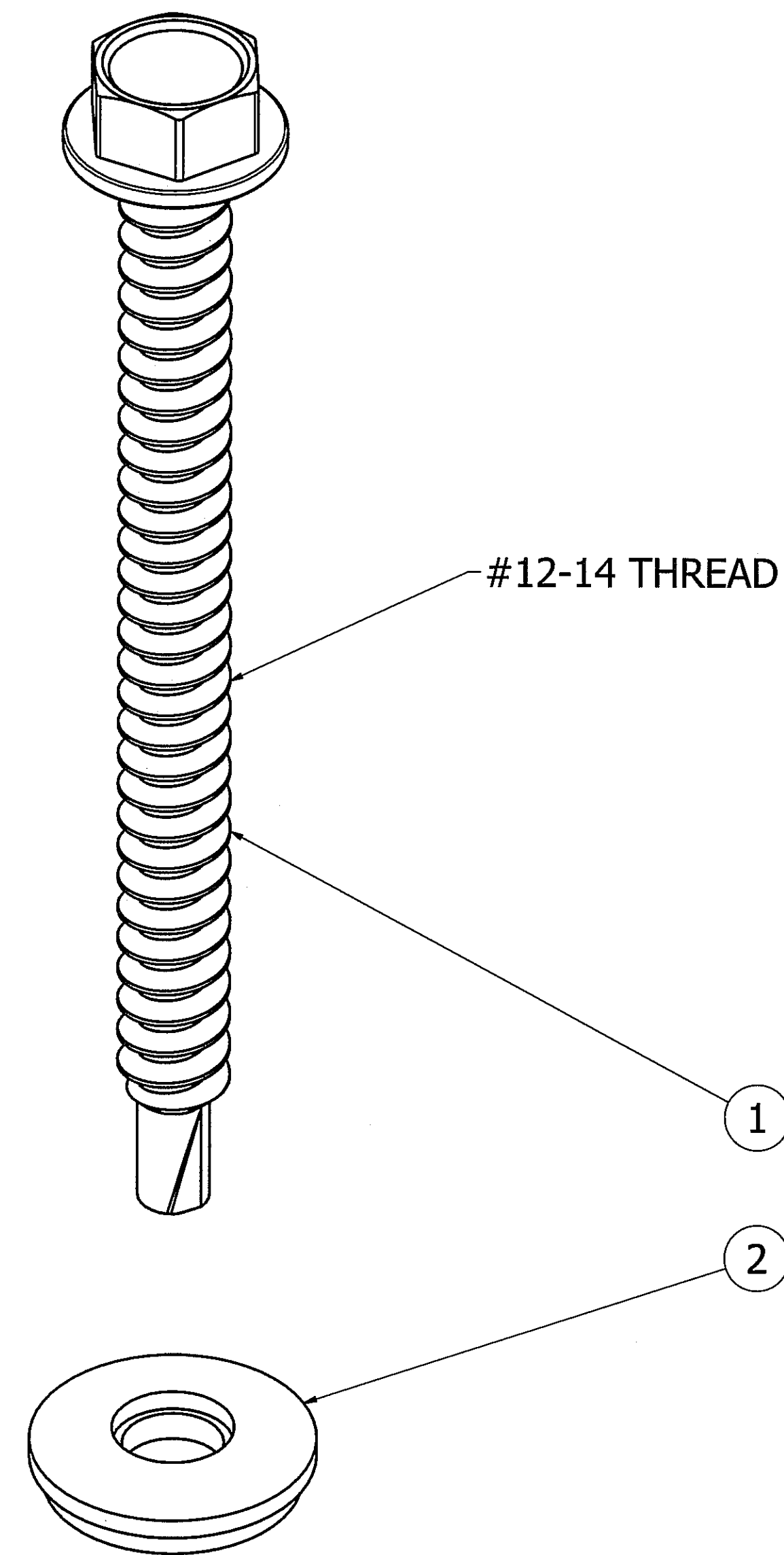
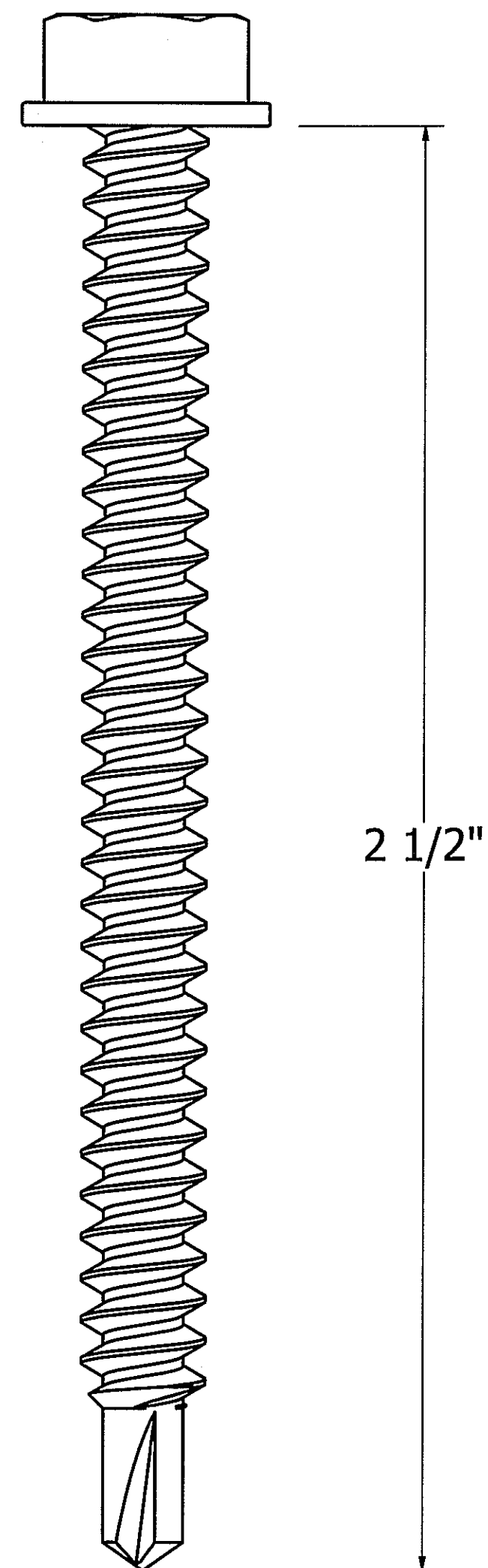

PRODUCT REVISED
 as complying with the Florida
 Building Code
 NOA-No. 24-0208.05
 Expiration Date 07/18/2027
 By [Signature]
 Miami-Dade Product Control

PE STAMP:

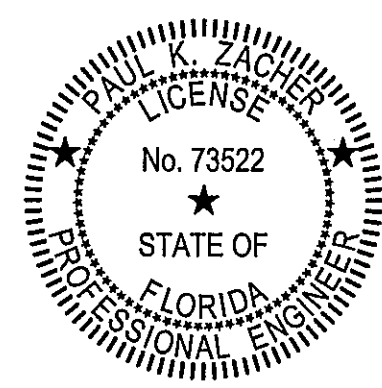

2023 FLORIDA BUILDING CODE, 8TH EDITION ASCE 7-22
 PE SIGNATURE: [Signature] PE DATE: 02/05/2024

PARTS LIST			
ITEM	QTY	PART NUMBER	DESCRIPTION
1	1	P28503023-250	#12-14 X 2.50 SCREW, HWH, SS, SELF-DR
2	1	P28503024 #12 EPDM WASHER	#12 EPDM WASHER

REVISIONS	CHK
1	-
DESCRIPTION	INITIAL RELEASE
REV DATE	4/05/22

FOR
 MIAMI-DADE
 COUNTY

PROJECT
 MIAMI-DADE CO.
 NOA

PROJECT ADDRESS

TITLE

DWG NO.

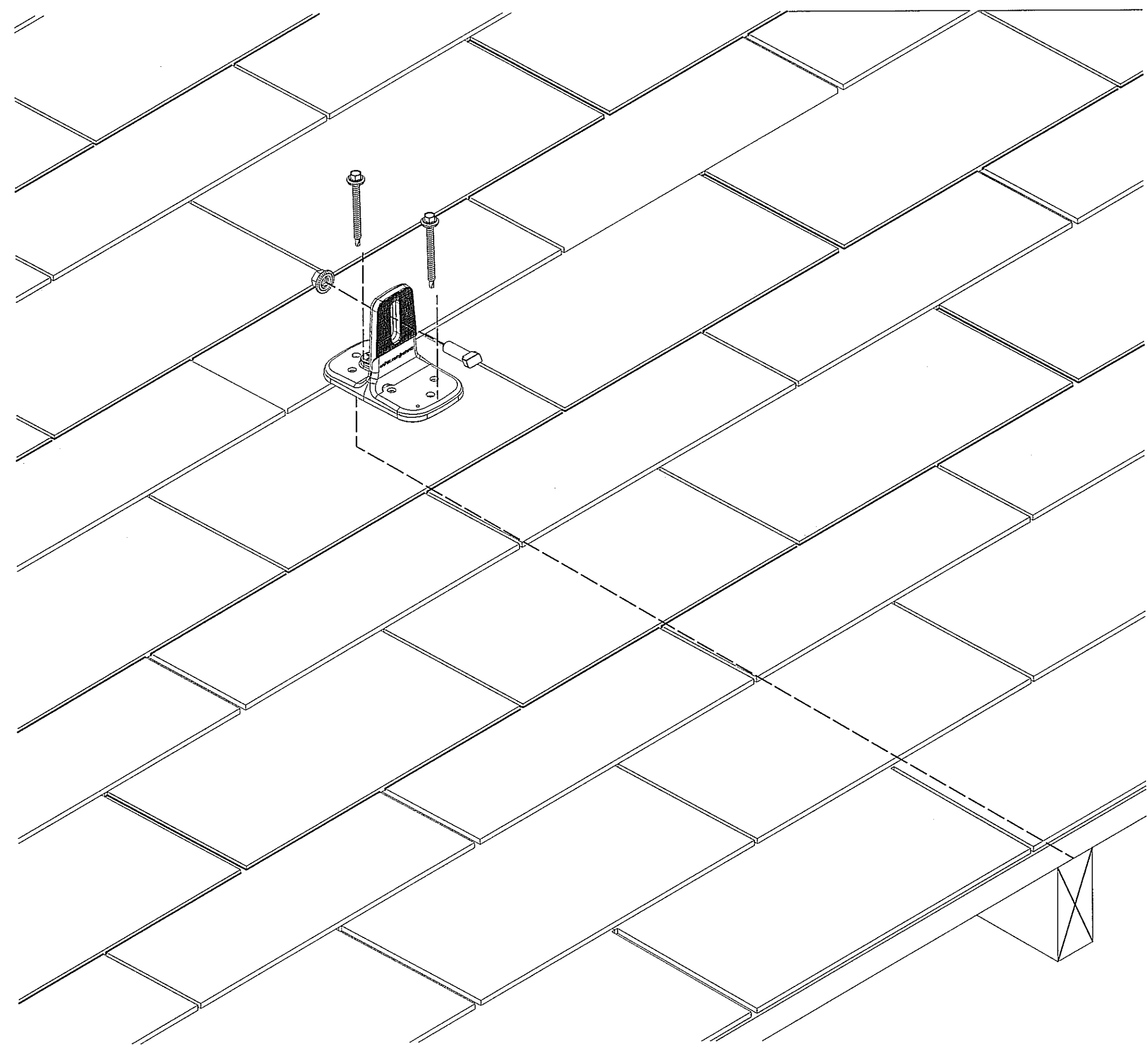

SOLARMOUNT FLASHLOC DUO INSTALLATION
NOT TO SCALE

STRUCTURAL MEMBER SPECIFICATION:

MINIMUM WOOD GRADE = SPF #2
MINIMUM SPECIFIC GRAVITY = 0.42

ALLOWABLE FASTENER UPLIFT = 594.7 lbs
ALLOWABLE FASTENER LATERAL = 204 lbs

MINIMUM FASTENER EDGE DISTANCE = 0.5"
MINIMUM FASTENER END DISTANCE = 2.2"

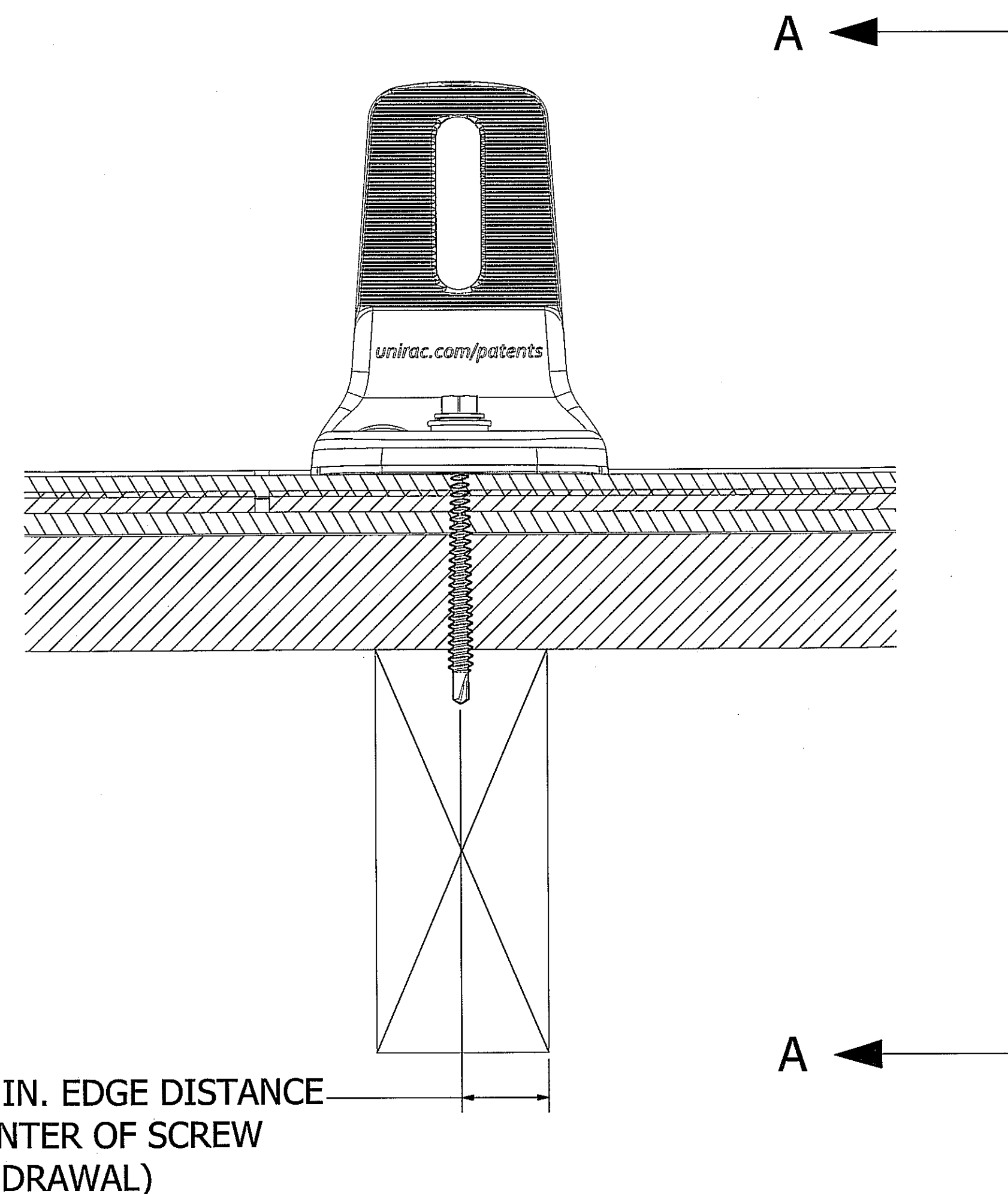

3/4" MIN. EDGE DISTANCE
TO CENTER OF SCREW
(WITHDRAWAL)

SECTION FLASHLOC DUO DETAIL
NOT TO SCALE

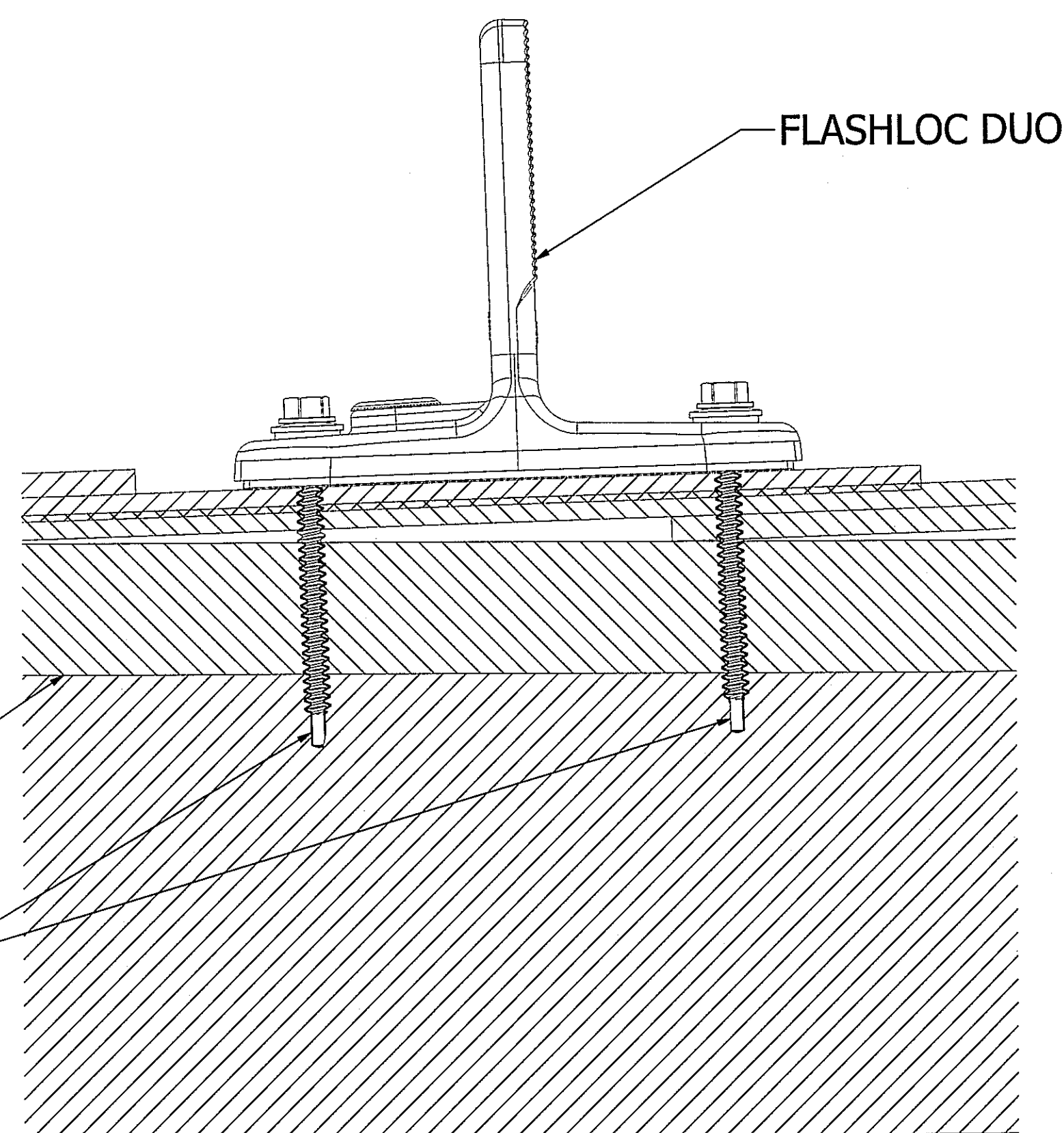

ROOF DECK
(STANDARD ROOF CONSTRUCTION)

2 - #12-14 SCREW, HWH, SS, SELF-DR
AND W/ #12 EPDM WASHER

BUILDING STRUCTURE
(WOOD FRAME)

SECTION A-A
NOT TO SCALE

REV DATE	DESCRIPTION	CHK
1 4/05/22	INITIAL RELEASE	-

FOR
MIAMI-DADE
COUNTY

PROJECT
MIAMI-DADE CO.
NOA

PROJECT ADDRESS

TITLE
SOLARMOUNT
SYSTEM
DETAILS

DWG NO.
M-D NOA
SHEET 6 OF 6

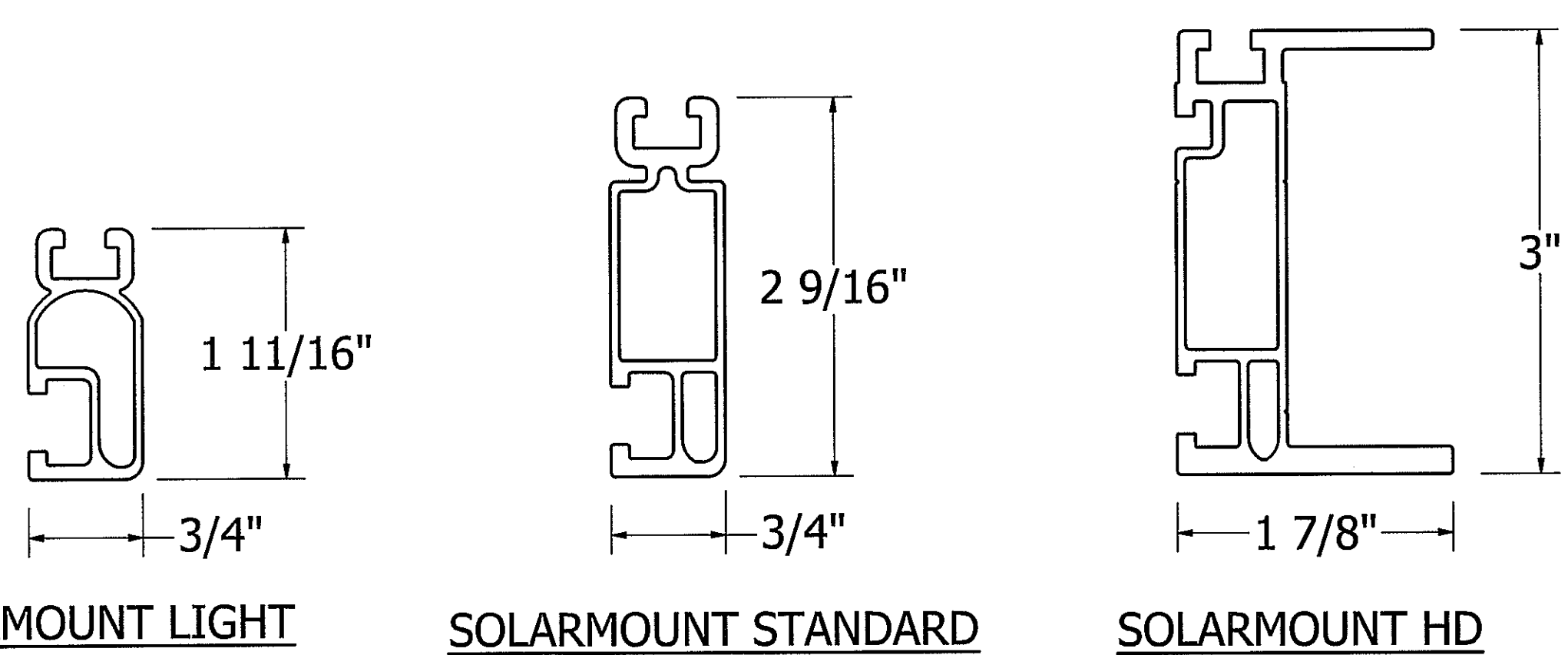

PRODUCT REVISED
as complying with the Florida
Building Code
NOA-No. 24-0208.05
Expiration Date 07/18/2027
By [Signature]
Miami-Dade Product Control

PE STAMP:
[Professional Engineer Seal]

2023 FLORIDA BUILDING CODE, 8TH EDITION ASCE 7-22
PE SIGNATURE: [Signature] PE DATE: 02/05/2024