



DEPARTMENT OF REGULATORY AND ECONOMIC RESOURCES (RER)
BOARD AND CODE ADMINISTRATION DIVISION

NOTICE OF ACCEPTANCE (NOA)

MIAMI-DADE COUNTY
PRODUCT CONTROL SECTION
11805 SW 26 Street, Room 208
Miami, Florida 33175-2474
T (786) 315-2590 F (786) 315-2599
www.miamidade.gov/economy

Attic Breeze LLC
1370 FM 116
Gatesville, TX 76528

SCOPE:

This NOA is being issued under the applicable rules and regulations governing the use of construction materials. The documentation submitted has been reviewed and accepted by Miami-Dade County RER-Product Control Section to be used in Miami Dade County and other areas where allowed by the Authority Having Jurisdiction (AHJ).

This NOA shall not be valid after the expiration date stated below. The Miami-Dade County Product Control Section (In Miami Dade County) and/or the AHJ (in areas other than Miami Dade County) reserve the right to have this product or material tested for quality assurance purposes. If this product or material fails to perform in the accepted manner, the manufacturer will incur the expense of such testing and the AHJ may immediately revoke, modify, or suspend the use of such product or material within their jurisdiction. RER reserves the right to revoke this acceptance if it is determined by Miami-Dade County Product Control Section that this product or material fails to meet the requirements of the applicable building code.

This product is approved as described herein and has been designed to comply with the Florida Building Code, including the High Velocity Hurricane Zone.

DESCRIPTION: Cardinal Ventilation Model CV-XLP/XLP Pro Aluminum Solar Attic Fan

APPROVAL DOCUMENT: Drawing No. **ATBR0002**, titled "Cardinal Ventilation CV-XLP/XLP Pro Model Series Aluminum Solar Attic Fan", sheets 1 through 4 of 4, dated 06/09/2025, prepared by Amoruso Consulting Eng., LLC, signed and sealed by Robert J. Amoruso, P.E., bearing the Miami-Dade County Product Control approval stamp with the Notice of Acceptance number and approval date by the Miami-Dade County Product Control Section.

MISSILE IMPACT RATING: None

LABELING: Each unit shall bear a permanent label with the manufacturer's name or logo, city, state, model/series, and following statement: "Miami-Dade County Product Control Approved", unless otherwise noted herein.

RENEWAL of this NOA shall be considered after a renewal application has been filed and there has been no change in the applicable building code negatively affecting the performance of this product.

TERMINATION of this NOA will occur after the expiration date or if there has been a revision or change in the materials, use, and/or manufacture of the product or process. Misuse of this NOA as an endorsement of any product, for sales, advertising or any other purposes shall automatically terminate this NOA. Failure to comply with any section of this NOA shall be cause for termination and removal of NOA.

ADVERTISEMENT: The NOA number preceded by the words Miami-Dade County, Florida, and followed by the expiration date may be displayed in advertising literature. If any portion of the NOA is displayed, then it shall be done in its entirety.

INSPECTION: A copy of this entire NOA shall be provided to the user by the manufacturer or its distributors and shall be available for inspection at the job site at the request of the Building Official.

This NOA consists of this page 1 and evidence page E-1, as well as approval document mentioned above. The submitted documentation was reviewed by **Carlos M. Utrera, P.E.**



09/23/25

NOA No. 25-0623.06
Expiration Date: September 25, 2030
Approval Date: September 25, 2025

NOTICE OF ACCEPTANCE: EVIDENCE SUBMITTED

A. DRAWINGS

1. Drawing No. **ATBR0002**, titled “Cardinal Ventilation CV-XLP/XLP Pro Model Series Aluminum Solar Attic Fan”, sheets 1 through 4 of 4, dated 06/09/2025, prepared by Amoruso Consulting Eng., LLC, signed and sealed by Robert J. Amoruso, P.E.

B. TESTS

1. Test report Uniform Static Air Pressure Test, Loading per FBC TAS 202-94 along with marked-up drawings and installation diagram of Cardinal Ventilation Model CV-XLP/XLP Pro Series Aluminum Solar Attic Fan, prepared by QAI Laboratories, Test Report No. **MED-3208a**, dated 08/29/2025, signed and sealed by Idalmis Ortega, P.E.
2. Test report Uniform Static Air Pressure Test, Loading per FBC TAS 100A, along with marked-up drawings and installation diagram of Cardinal Ventilation CV-XLP/XLP Pro Model Series Aluminum Solar Attic Fan, prepared by FTL a QAI Company, Test Report No. **12036**, dated 03/21/2020, signed and sealed by Idalmis Ortega, P.E.

C. CALCULATIONS

1. Anchoring calculations prepared by Amoruso Consulting Eng., LLC, dated 06/09/2025, signed and sealed by Robert J. Amoruso, P.E.

D. QUALITY ASSURANCE

1. Miami-Dade Department of Regulatory and Economic Resources (RER).

E. MATERIAL CERTIFICATIONS

1. None.

F. STATEMENTS

1. Statement letter of code conformance to the 8th edition (2023) FBC and of no financial interest, issued by Amoruso Consulting Eng., LLC, dated 06/09/2025, signed and sealed by Robert J. Amoruso, P.E.



Carlos M. Utrera, P.E.
Product Control Examiner
NOA No. 25-0623.06
Expiration Date: September 25, 2030
Approval Date: September 25, 2025

ATTIC BREEZE

CARDINAL VENTILATION CV-XLP/XLP PRO MODEL SERIES SOLAR ATTIC FAN INSTALLATION ANCHORAGE DETAILS

Attic Breeze
P.O. Box 1318, 1370 FM 116
Gatesville, Texas 76528

GENERAL NOTES:

- THE PRODUCT ANCHORAGE SHOWN HEREIN IS DESIGNED TO COMPLY WITH THE CURRENT EDITION OF THE FLORIDA BUILDING AND RESIDENTIAL CODES INCLUDING THE HIGH VELOCITY HURRICANE ZONE (HVHZ) AT THE DESIGN PRESSURES STATED HEREIN.
- PERFORMANCE TESTING BASED UPON SIGNED AND SEALED TEST REPORTS BY IDALMIS ORTEGA, FLORIDA LICENSE NO. 76905 AS FOLLOWS:
 - QAI LABORATORIES, MEDLEY, FL, 33166. TEST REPORT NO. MED-3208a, DATED 08/29/25.
 - TEST FOR STRUCTURAL PERFORMANCE TO TAS 202-94 (STRUCTURAL LOADING ONLY) AT A TEST LOAD OF -220 PSF.
 - SAFETY FACTOR OF 2 APPLIED TO STRUCTURAL TEST LOAD RESULTS YIELDS DESIGN PRESSURE OF -110 PSF.
 - FTL, MEDLEY, FL, 33166. TEST REPORT NO. 12036, DATED 03/21/20
 - TEST FOR WIND-DRIVEN RAIN RESISTANCE PER TAS 100(A)-95, SECTION 10.3 WAS PERFORMED.
 - STRUCTURAL TESTING FOR INCREASED WINDSPEED RESISTANCE FOR VENTS PER TAS 100(A)-95.7, SECTION 10.4 WAS PERFORMED.
 - AN INSTALLATION HEIGHT NOT TO EXCEED 75 FEET IS APPLICABLE BASED ON TAS 100(A)-95, TABLE 3.
 - TESTING CONDUCTED USING ASPHALT SHINGLES.
- FOR ROOF MOUNTING: ADEQUACY OF THE EXISTING STRUCTURAL ROOF SHEATHING AND SUPPORTING 2X FRAMING AS A MAIN WIND FORCE RESISTING SYSTEM CAPABLE OF WITHSTANDING AND TRANSFERRING APPLIED PRODUCT LOADS TO THE FOUNDATION IS THE RESPONSIBILITY OF THE ENGINEER OR ARCHITECT OF RECORD FOR THE PROJECT OF INSTALLATION.
- THE INSTALLATION DETAILS DESCRIBED HEREIN ARE GENERIC AND MAY NOT REFLECT ACTUAL CONDITIONS FOR A SPECIFIC SITE. IF SITE CONDITIONS CAUSE INSTALLATION TO DEVIATE FROM THE REQUIREMENTS DETAILED HEREIN, A LICENSED ENGINEER OR ARCHITECT SHALL PREPARE SITE SPECIFIC DOCUMENTS FOR USE WITH THIS DOCUMENT.
- HOOD & FLASHING MATERIAL: 0.080" 3003-0 ALUMINUM.
- PRIOR TO A HURRICANE OR ANTICIPATED HIGH WIND EVENT, THE SOLAR PANEL SHALL BE PLACED IN THE RETRACTED POSITION WHERE APPLICABLE.
- SOLAR ATTIC FAN MAY BE INSTALLED ON ROOFS WITH SLOPES FROM 9 DEGREES (2" RISE OVER 12" RUN) TO 45 DEGREES (RISE EQUALS RUN).
- THIS PRODUCT EVALUATION DOCUMENT ADDRESSES THE STRUCTURAL ATTACHMENT OF THE ROOF VENT TO THE ROOF SHEATHING ONLY. PREPARATION OF THE ROOF SHEATHING AND ROOF COVERING(S) TO RECEIVE THE ROOF VENT SHALL BE PER THE MANUFACTURER'S INSTRUCTIONS AND IN ACCORDANCE WITH CHAPTER 15 OF THE FLORIDA BUILDING CODE AND CHAPTER 9 OF THE FLORIDA RESIDENTIAL CODE.
- THIS APPROVAL IS FOR THE STRUCTURAL PERFORMANCE ONLY. IMPACT RESISTANCE WAS NOT TESTED. INTERIOR MECHANISM AND/OR ELECTRICAL CIRCUITRY ARE OUTSIDE THE SCOPE OF THIS PRODUCT APPROVAL DOCUMENT.

INSTALLATION NOTES:

- ONE (1) INSTALLATION ANCHOR IS REQUIRED AT EACH ANCHOR LOCATION SHOWN.
- THE NUMBER OF INSTALLATION ANCHORS DEPICTED (QUANTITY OF 8 ANCHORS) ARE THE MINIMUM NUMBER OF ANCHORS TO BE USED FOR PRODUCT INSTALLATION AS FOLLOWS:
 - 2X WOOD FRAMING
 - A MINIMUM OF EIGHT (8) ANCHORS SHALL BE USED.
 - PLYWOOD ROOF SHEATHING, THE GREATER OF
 - A MINIMUM OF EIGHT (8) ANCHORS SHALL BE USED, OR
 - AS REQUIRED BY THE INSTALLATION ANCHOR SCHEDULE ON SHEET 4.
- ANCHOR TYPE AND SIZE;
 - FOR INSTALLATION INTO WOOD FRAMING, USE #10 WOOD SCREWS OR #10 SELF-TAPPING/SELF-DRILLING SCREWS OF SUFFICIENT LENGTH TO ACHIEVE 1 1/2 INCH MINIMUM EMBEDMENT INTO 2X WOOD STRUCTURAL SUBSTRATE. MINIMUM EDGE DISTANCE IS 3/8 INCHES AND MINIMUM END DISTANCE IS 3/4 INCHES.
 - FOR INSTALLATION INTO ROOF SHEATHING, USE #10 SELF-TAPPING/SELF-DRILLING SCREWS OF SUFFICIENT LENGTH TO ACHIEVE FULL THREAD EMBEDMENT INTO STRUCTURAL SUBSTRATE. SELF-TAPPING/SELF-DRILLING SCREWS (a.k.a., SHEET METAL SCREWS) ARE THREADED THE FULL LENGTH AND REQUIRED TO ENSURE FULL THREAD ENGAGEMENT INTO SHEATHING.
 - ANCHOR SPECIFICATIONS
 - WOOD SCREWS WILL BE NO. 10 PAN HEAD WOOD SCREW, MEETING ANSI B18.6.1, CARBON OR STAINLESS STEEL, CORROSION RESISTANT BY COATING OR MATERIAL.
 - TAPPING SCREWS SHALL BE NO. 10 TYPE AB PAN HEAD TAPPING SCREW, MEETING ASME/ANSI B18.6.4, CARBON OR STAINLESS STEEL, CORROSION RESISTANT BY COATING OR MATERIAL.
 - HEX HEAD SCREWS CAN BE USED IN LIEU OF PAN HEAD SCREWS.
 - NEOPRENE WASHERS SHALL BE USED AND PLACED UNDER THE HEAD OF THE SCREW.
- MINIMUM EMBEDMENT AND EDGE DISTANCE EXCLUDE ROOFING FINISHES, INCLUDING BUT NOT LIMITED TO ROOF SHEATHING, SHINGLES, UNDERLAYMENTS, ETC.
- INSTALLATION ANCHOR CAPACITIES FOR PRODUCTS HEREIN ARE BASED ON SUBSTRATE MATERIALS WITH THE FOLLOWING PROPERTIES:
 - 2 BY WOOD FRAMING (FOR 2X WOOD FRAMING INSTALLATION OPTION)
 - MINIMUM SPECIFIC GRAVITY OF 0.55 INSIDE HVHZ.
 - PLYWOOD RATING
 - PLYWOOD SHALL BE RATED FOR EXPOSURE 1 PER FBC SECTION 2322.2.3.
- ADDITIONAL INSTALLATION INSTRUCTIONS
 - PRODUCT SHALL NOT BE INSTALLED ON ROOF SHEATHING LESS THAN THE REQUIRED THICKNESS AS REQUIRED BY THE FLORIDA BUILDING CODE.
 - PRODUCT CAN BE INSTALLED ON ROOFS UTILIZING ASPHALT SHINGLES.
 - SEE MANUFACTURER'S INSTALLATION INSTRUCTIONS (CARDINAL VENTILATION INSTALLATION GUIDE FOR CV-XLP AND CV-XLP PRO) FOR ADDITIONAL DETAILS.

NO.	REVISION DESCRIPTION	BY	DATE

DATE: 6/9/2025	DWN BY: RIA	CHK BY: n/a	SCALE: NONE
-------------------	----------------	----------------	----------------

ROBERT J. AMORUSO, P.E. #49752
AMORUSO CONSULTING ENG., LLC
FBPE REGISTRATION NO. 38327
226 N NOVA RD, NO. 142
ORMOND BEACH, FL 32174
RJAENGPE@GMAIL.COM



TABLE OF CONTENT	
SHEET	DESCRIPTION
1	GENERAL NOTES & INSTALLATION NOTES
2	ELEVATION WITH ANCHORAGE LOCATIONS & SECTIONS
3	2X WOOD OR PLYWOOD ROOF SHEATHING INSTALLATION
4	ROOF SHEATHING INSTALLATION ANCHOR SCHEDULE AND INSTALLATION NOTES

PERFORMANCE RATING - HVHZ	
DESIGN PRESSURE (PSF)	IMPACT RATING
-110	NONE
SEE GENERAL NOTE 2 FOR TAS 100(A) TESTING RESULTS.	

PRODUCT APPROVED
as complying with the Florida
Building Code
NOA-No. 25-0623.06
Approval Date 09/25/2025
By *[Signature]*
Miami-Dade Product Control

PROJECT#: ACE-2025-116
DWG/REV: ATBR0002, Rev 0
SHT: 1 of 4

Attic Breeze
P.O. Box 1318, 1370 FM 116
Gatesville, Texas 76528

PRODUCT APPROVED
as complying with the Florida
Building Code
NOA-No. 25-0623.06
Approval Date 09/25/2025
By *[Signature]*
Miami-Dade Product Control

NO.	REVISION DESCRIPTION	BY	DATE

DATE: 6/9/2025	DWN BY: RJA	CHK BY: n/a	SCALE: NONE
-------------------	----------------	----------------	----------------

ROBERT J. AMORUSO, P.E. #49752
AMORUSO CONSULTING ENG., LLC
FBPE REGISTRATION NO. 38327
226 N NOVA RD, NO. 142
ORMOND BEACH, FL 32174
RJAENGPE@GMAIL.COM



PROJECT#: ACE-2025-116

DWG/REV: ATBR0002, Rev 0

SHT: 2 of 4

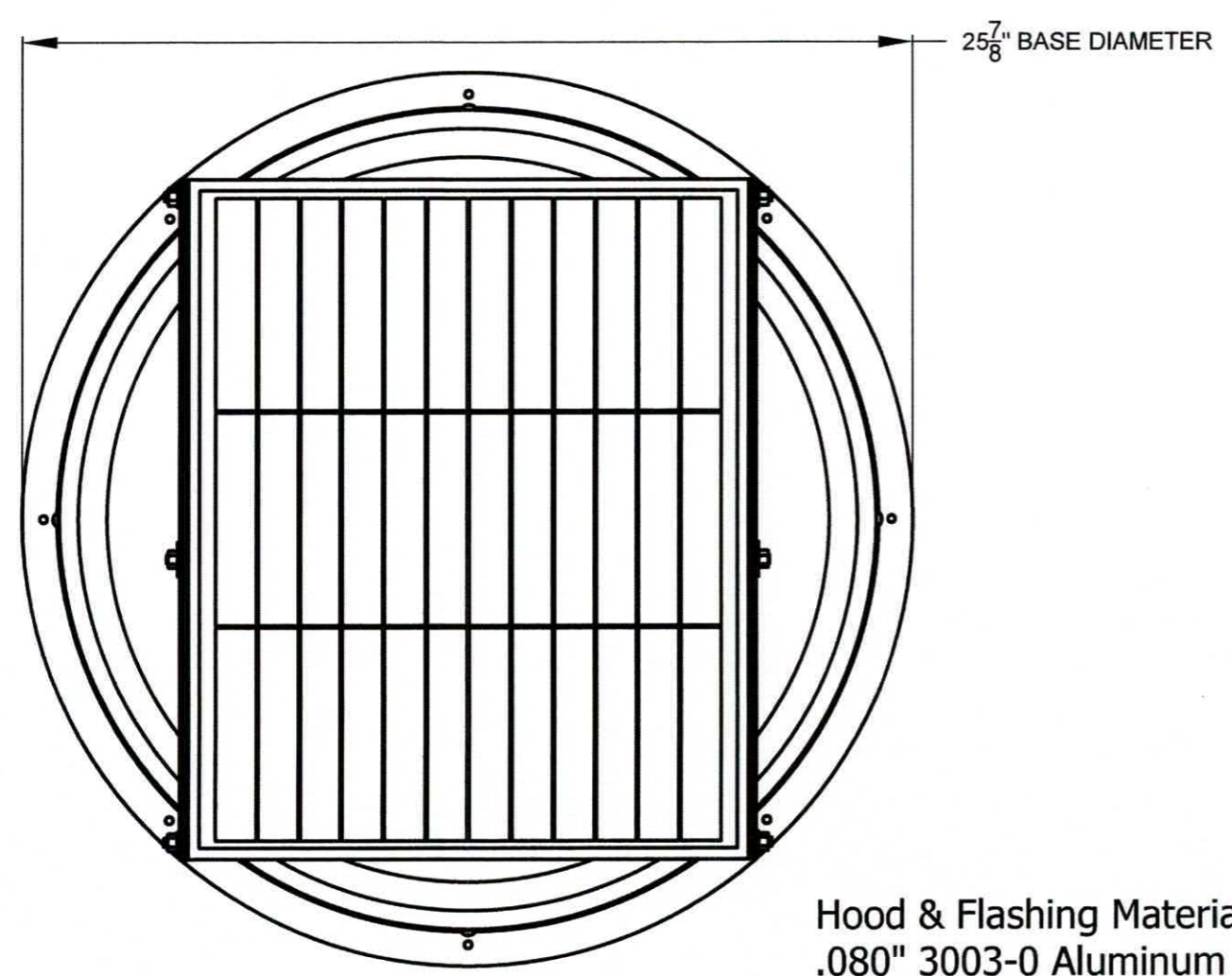

Top View
SCALE 1/3

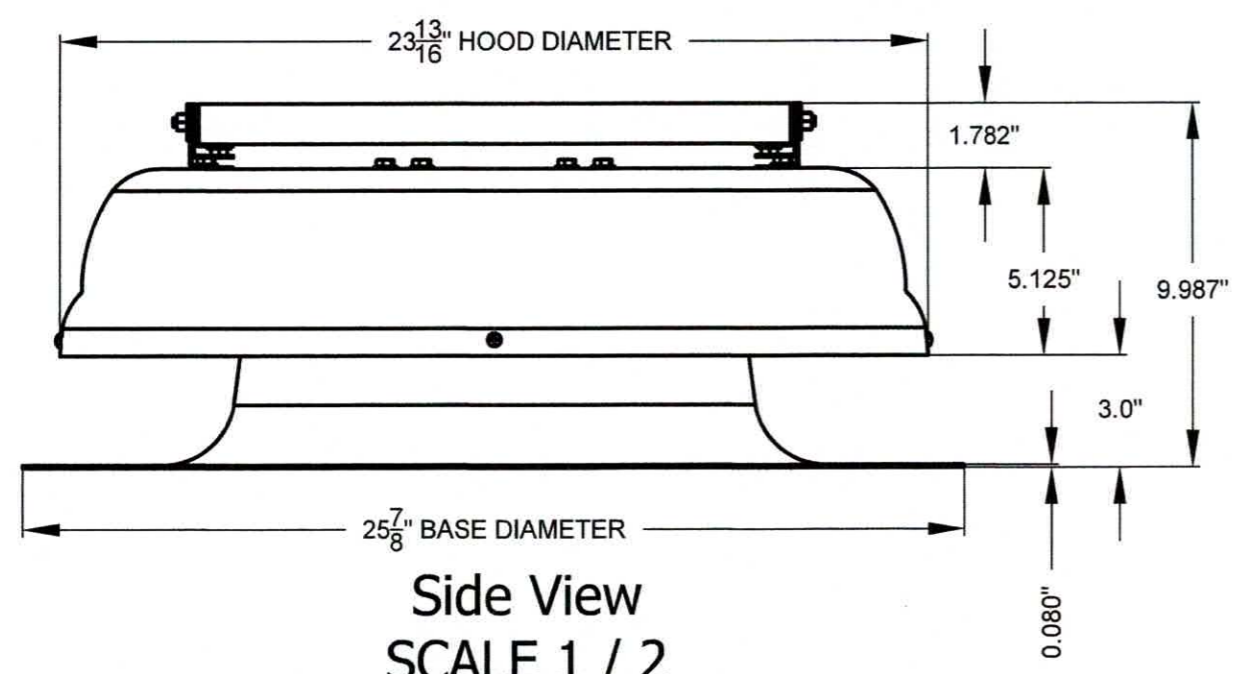

Side View
SCALE 1 / 2

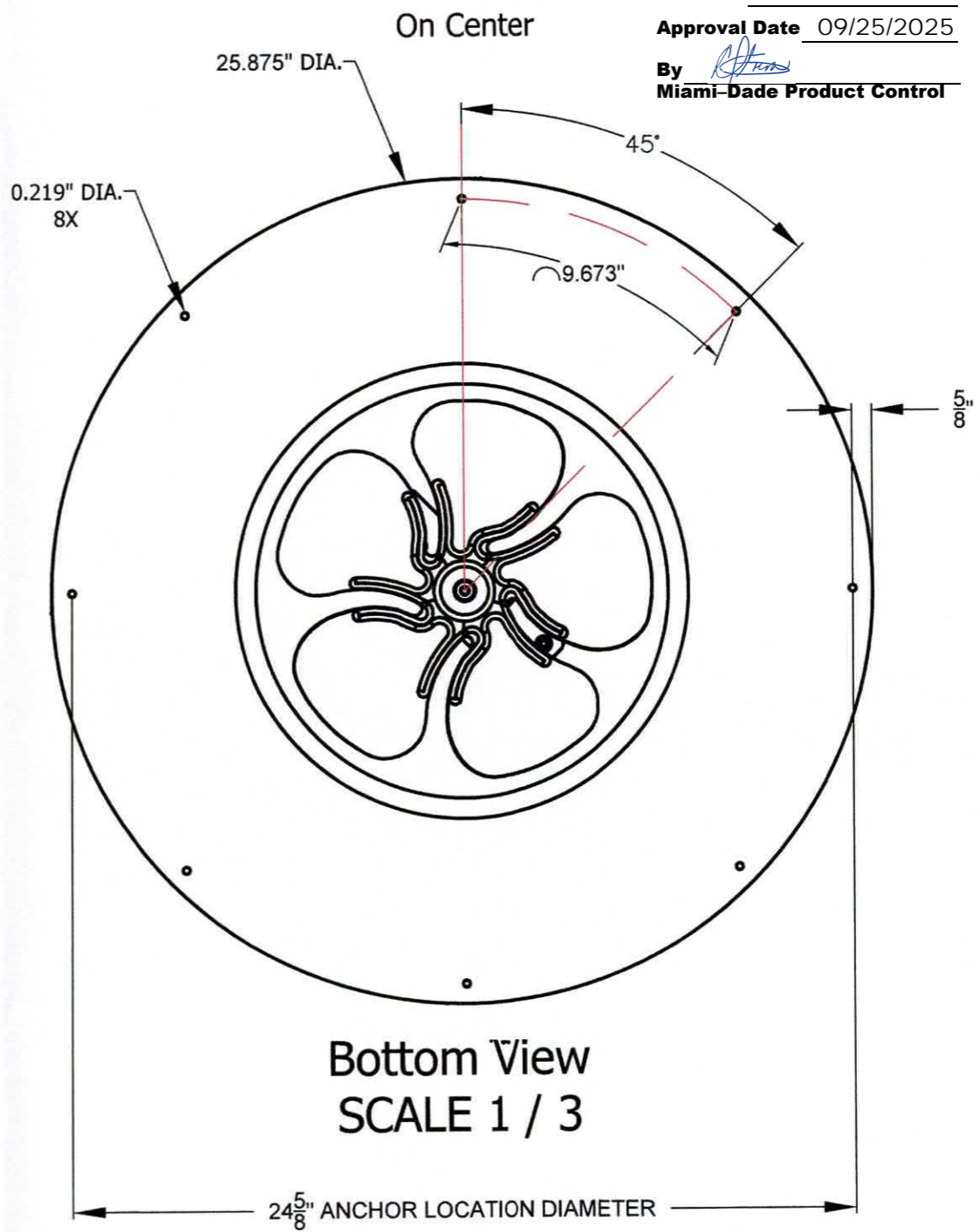

Bottom View
SCALE 1 / 3

SEE SHEET 4 FOR ADDITIONAL ANCHOR INSTALLATION REQUIREMENTS. ANCHOR QUANTITY IS MINIMUM EIGHT(8) AS SHOWN ABOVE. ADDITIONAL ANCHORS MAY BE REQUIRED BASED ON SITE DESIGN PRESSURE AND SUBSTRATE MATERIALS.

PLYWOOD OR OSB ROOF SHEATHING INSTALLATION

Attic Breeze
 P.O. Box 1318, 1370 FM 116
 Gatesville, Texas 76528

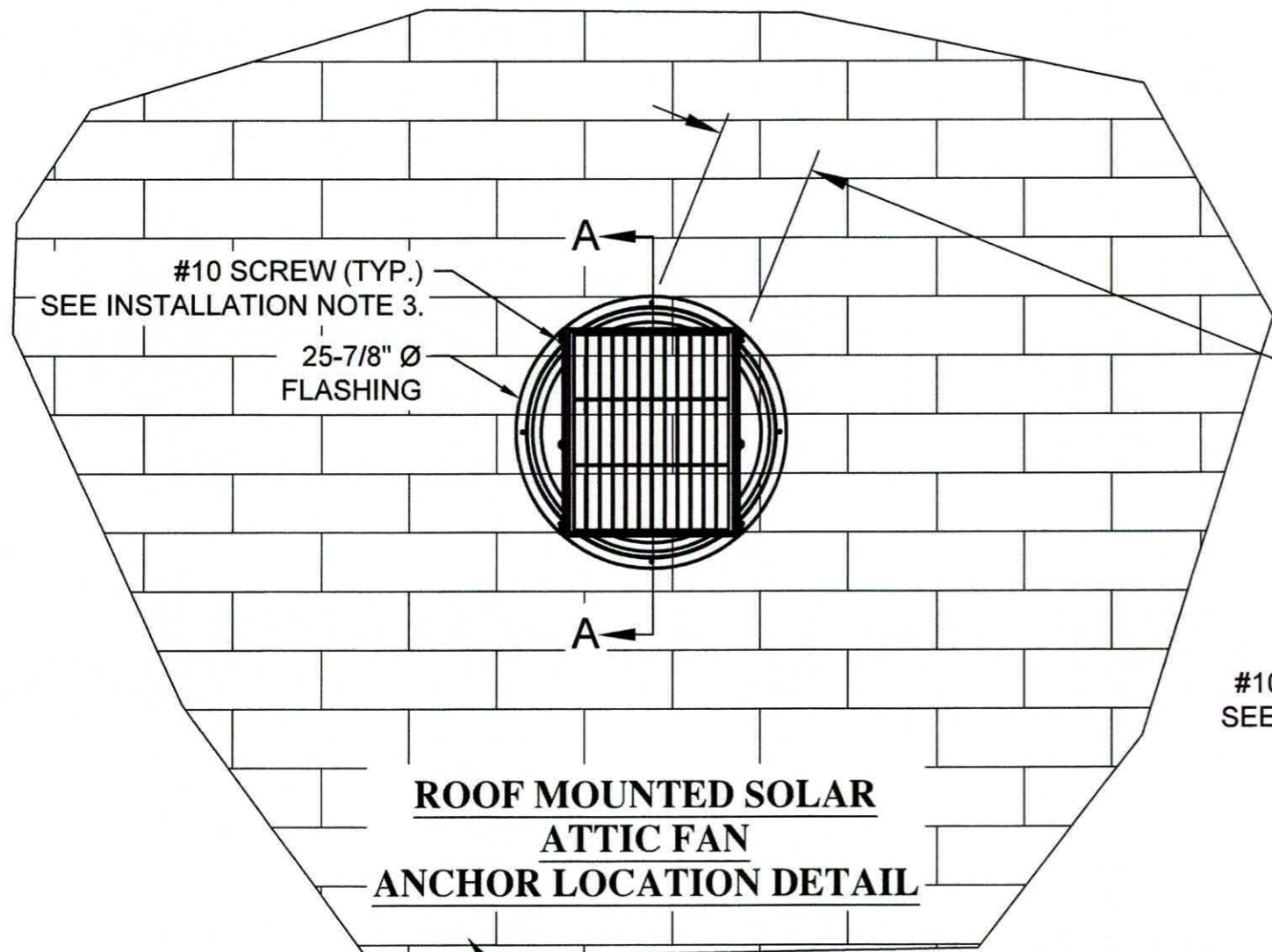

9.637" O.C. TYP.
 FOR QTY. = 8 ANCHORS MIN.
 (SEE ANCHOR QTY. TABLE)

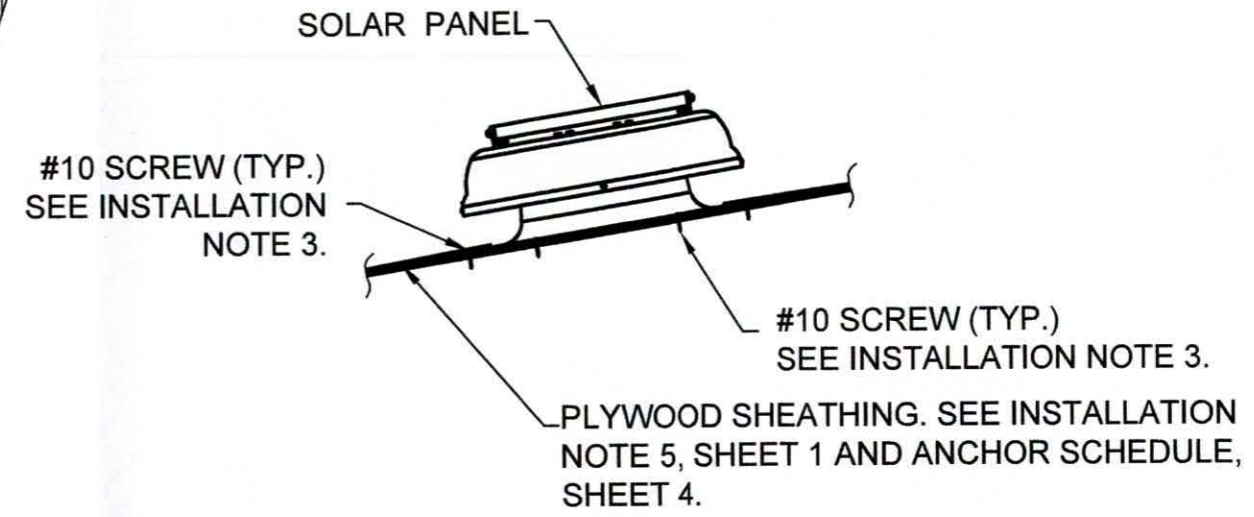

- NOTES:
1. SEE SHEET 4 FOR INSTALLATION ANCHOR SCHEDULE AND REQUIRED ANCHOR QUANTITIES.
 2. SEE INSTALLATION NOTE 5 ON SHEET 1 FOR MATERIAL REQUIREMENTS AND SHEATHING THICKNESS.
 - 2.1. FOR THICKNESSES OTHER THAN THAT SHOWN ON SHEET 4, USE THE NEXT THINNER THICKNESS.

NO.	REVISION DESCRIPTION	BY	DATE

DATE: 6/9/2025	DWN BY: RJA	CHK BY: n/a	SCALE: NONE
-------------------	----------------	----------------	----------------

ROBERT J. AMORUSO, P.E. #49752
 AMORUSO CONSULTING ENG., LLC
 FBPE REGISTRATION NO. 38327
 226 N NOVA RD, NO. 142
 ORMOND BEACH, FL 32174
 RJAENGPE@GMAIL.COM

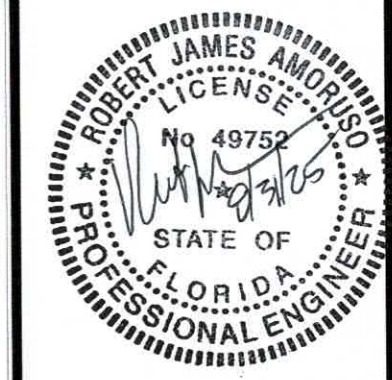

PRODUCT APPROVED
 as complying with the Florida
 Building Code
 NOA-No. 25-0623.06
 Approval Date 09/25/2025
 By *[Signature]*
 Miami-Dade Product Control

PROJECT#: ACE-2025-116
 DWG/REV: ATBR0002, Rev 0
 SHT: 3 of 4

PLYWOOD ROOF SHEATHING INSTALLATION ANCHOR SCHEDULE

Attic Breeze
P.O. Box 1318, 1370 FM 116
Gatesville, Texas 76528

SUBSTRATE		QUANTITY OF INSTALLATION ANCHORS AT VARIOUS DESIGN PRESSURES (psf)					
Type	Thickness	up to -85 psf	-90 psf	-95 psf	-100 psf	-105 psf	-110 psf
2X FRAMING		8	8	8	8	8	8
Plywood Exposure 1	7/16"	8	8	8	8	8	9
	15/32"	8	8	8	8	8	8
	1/2"	8	8	8	8	8	8
	5/8"	8	8	8	8	8	8
	3/4"	8	8	8	8	8	8

ROOF SHEATHING INSTALLATION ANCHOR SCHEDULE AND INSTALLATION NOTES:

1. SEE SHEET 1, INSTALLATION NOTES FOR ANCHOR SIZE, TYPE AND EMBEDMENT REQUIREMENTS.
2. TABLE ABOVE SHOWS QUANTITY OF ANCHORS REQUIRED FOR THE FOLLOWING:
 - 2.1. VARIOUS DESIGN PRESSUES (DP) IN POUNDS PER SQUARE FOOT (PSF),
 - 2.2. PLYWOOD, EXPOSURE 1.
3. USE THIS TABLE AS FOLLOWS:
 - 3.1. DETERMINE THICKNESS OF ROOF SHEATHING.
 - 3.2. DETERMINE REQUIRED NEGATIVE (UPLIFT) DESIGN PRESSURE FOR PROJECT'S PHYSICAL LOCATION.
 - 3.3. ENTER TABLE TO DETERMINE QUANTITY OF ANCHORS (SELF-TAPPING SCREWS REQUIRED FOR SHEATHING ONLY WHERE ANCHORS WILL NOT ENGAGE IN 2X FRAMING).
4. QUANTITY OF ANCHORS SHALL NEVER BE LESS THAN EIGHT (8).
 - 4.1. ATTIC FAN WAS TESTED WITH EIGHT (8) ANCHORS AT 9-11/16" O.C. PERIMETER SPACING. THEREFORE, MINIMUM REQUIRED ANCHOR QUANTITY IS EIGHT (8).
 - 4.2. ANCHOR QUANTITY MAY BE GREATER THEN EIGHT (8) BASED ON DESIGN PRESSURE REQUIREMENTS OF INSTALLATION AND/OR SUBSTRATE MATERIALS PER TABLE ON THIS SHEET.
5. SPACING SHOWN ON SHEET 2 BASED ON THE FOLLOWING.
 - 5.1. QUANTITY OF ANCHORS EIGHT (8).
 - 5.2. ANCHORS LOCATED IN CIRCULAR MANNER IN A PERIMETER CIRCLE OF 24-5/8" DIAMETER.
 - 5.3. EIGHT (8 ANCHORS) SPACED EVENLY ON 24-5/8" DIAMETER ARE SPACED 9-11/16" ON CENTER (O.C.).
 - 5.4. SPACING MAY BE LESS BUT CANNOT EXCEED 9-11/16" O.C.
 - 5.5. SPACING WILL BE LESS WHEN ANCHOR QUANTITY EXCEEDS EIGHT (8) ANCHORS.

PRODUCT APPROVED
as complying with the Florida
Building Code

NOA-No. 25-0623.06

Approval Date 09/25/2025

By 
Miami-Dade Product Control

CARDINAL VENTILATION CV-XLP/XLP PRO MODEL SERIES SOLAR ATTIC FAN - ANCHORAGE DETAILS	DATE			
	BY			
REVISION DESCRIPTION				
NO.				

DATE: 6/9/2025	DWN BY: RJA	CHK BY: n/a	SCALE: NONE
-------------------	----------------	----------------	----------------

ROBERT J. AMORUSO, P.E. #49752
AMORUSO CONSULTING ENG., LLC
FBPE REGISTRATION NO. 38327
226 N NOVA RD, NO. 142
ORMOND BEACH, FL 32174
RJAENGPE@GMAIL.COM



PROJECT#: ACE-2025-116

DWG/REV: ATBR0002, Rev 0

SHT: 4 of 4