



DEPARTMENT OF REGULATORY AND ECONOMIC RESOURCES (RER)  
BOARD AND CODE ADMINISTRATION DIVISION

MIAMI-DADE COUNTY  
PRODUCT CONTROL SECTION  
11805 SW 26 Street, Room 208  
Miami, Florida 33175-2474  
T (786) 315-2590 F (786) 315-2599

**NOTICE OF ACCEPTANCE (NOA)**

[www.miamidade.gov/economy](http://www.miamidade.gov/economy)

**Lott's Concrete Products, Inc.**  
**P.O. Box 771255**  
**Winter Garden, Florida 34787**

**SCOPE:**

This NOA is being issued under the applicable rules and regulations governing the use of construction materials. The documentation submitted has been reviewed and accepted by Miami-Dade County RER- Product Control Section to be used in Miami Dade County and other areas where allowed by the Authority Having Jurisdiction (AHJ).

This NOA shall not be valid after the expiration date stated below. The Miami-Dade County Product Control Section (In Miami Dade County) and/or the AHJ (in areas other than Miami Dade County) reserve the right to have this product or material tested for quality assurance purposes. If this product or material fails to perform in the accepted manner, the manufacturer will incur the expense of such testing and the AHJ may immediately revoke, modify, or suspend the use of such product or material within their jurisdiction. RER reserves the right to revoke this acceptance if it is determined by Miami-Dade County Product Control Section that this product or material fails to meet the requirements of the applicable building code.

This product is approved as described herein and has been designed to comply with the High Velocity Hurricane Zone of the Florida Building Code.

**DESCRIPTION: "Lott's Concrete" 8 inch High Strength Precast and Prestressed Concrete Lintels**

**APPROVAL DOCUMENT:** Drawing No. SK, titled "Lott's Concrete 8" Lintel Load Tables", sheets 1 through 5 of 5, prepared by Florida Engineering Solutions, Inc., dated Oct. 24, 2020, signed and sealed by John Ashby Hoy, P.E., on Oct. 24, 2020, bearing the Miami-Dade County Product Control Revision stamp with the Notice of Acceptance number and the expiration date by the Miami-Dade County Product Control Section.

**MISSILE IMPACT RATING: Large and Small Missile Impact Resistant**

**LABELING:** Each lintel shall bear a permanent label with the manufacturer's name or logo and the Miami-Dade County logo.

**RENEWAL** of this NOA shall be considered after a renewal application has been filed and there has been no change in the applicable building code negatively affecting the performance of this product.

**TERMINATION** of this NOA will occur after the expiration date or if there has been a revision or change in the materials, use, and/or manufacture of the product or process. Misuse of this NOA as an endorsement of any product, for sales, advertising or any other purposes shall automatically terminate this NOA. Failure to comply with any section of this NOA shall be cause for termination and removal of NOA.

**ADVERTISEMENT:** The NOA number preceded by the words Miami-Dade County, Florida, and followed by the expiration date may be displayed in advertising literature. If any portion of the NOA is displayed, then it shall be done in its entirety.

**INSPECTION:** A copy of this entire NOA shall be provided to the user by the manufacturer or its distributors and shall be available for inspection at the job site at the request of the Building Official.

This NOA **revises & renews** NOA # 20-1123.04 and consists of this page 1, evidence submitted pages E-1, E-2, E-3 & E-4 as well as approval document mentioned above.

The submitted documentation was reviewed by **Helmy A. Makar, P.E., M.S.**



*Helmy A. Makar*  
10/02/25

NOA No. 25-0624.03  
Expiration Date: 11/19/2030  
Approval Date: 10/02/2025

NOTICE OF ACCEPTANCE: EVIDENCE SUBMITTED

**1. EVIDENCE SUBMITTED UNDER PREVIOUS APPROVAL # 15-0526.12**

**A. DRAWINGS**

1. *Drawing No. SK, titled "Lott's Concrete 8" Lintel Load Tables", sheets 1 through 5 of 5, prepared by Florida Engineering Solutions, Inc., dated May 20, 2015, signed and sealed by John Ashby Hoy, P.E., on May 20, 2015.*

**B. TESTS**

1. *Test report on flexural **lateral load** testing on **Concrete Lintels**, per ASTM E-529-94, prepared by Hurricane Engineering & Testing, Inc., Report No. **HETI 14-M318**, dated 07/07/14, signed and sealed by Rafael E. Droz-Seda, P.E.*
2. *Test report on flexural **gravity load** testing on **Concrete Lintels**, per ASTM E-529-94, prepared by Hurricane Engineering & Testing, Inc., Report No. **HETI 15-M525**, dated 04/27/15, signed and sealed by Rafael E. Droz-Seda, P.E.*
3. *Test report on flexural **shear lateral load** testing on **Concrete Lintels**, per ASTM E-529-94, prepared by Hurricane Engineering & Testing, Inc., Report No. **HETI 14-M529**, dated 02/10/15, signed and sealed by Rafael E. Droz-Seda, P.E.*
4. *Test report on flexural **gravity load** testing on **Concrete Lintels**, per ASTM E-529-94, prepared by Hurricane Engineering & Testing, Inc., Report No. **HETI 14-M500**, dated 02/10/15, signed and sealed by Rafael E. Droz-Seda, P.E.*
5. *Test report on flexural **gravity load** testing on **Concrete Lintels**, per ASTM E-529-94, prepared by Hurricane Engineering & Testing, Inc., Report No. **HETI 14-M316**, dated 07/07/14, signed and sealed by Rafael E. Droz-Seda, P.E.*
6. *Test report on flexural **uplift load** testing on **Concrete Lintels**, per ASTM E-529-94, prepared by Hurricane Engineering & Testing, Inc., Report No. **HETI 14-M317**, dated 07/07/14, signed and sealed by Rafael E. Droz-Seda, P.E.*
7. *Test report on flexural **uplift load** testing on **Concrete Lintels**, per ASTM E-529-94, prepared by Hurricane Engineering & Testing, Inc., Report No. **HETI 15-M527**, dated 04/27/15, signed and sealed by Rafael E. Droz-Seda, P.E.*
8. *Test report on flexural **shear uplift load** testing on **Concrete Lintels**, per ASTM E-529-94, prepared by Hurricane Engineering & Testing, Inc., Report No. **HETI 14-M516**, dated 02/10/15, signed and sealed by Rafael E. Droz-Seda, P.E.*
9. *Test report on flexural **uplift, lateral, & gravity load** testing on **Concrete Face Sills**, per ASTM E-529-94, prepared by Hurricane Engineering & Testing, Inc., Report No. **HETI 14-M446**, dated 06/13/14, signed and sealed by Rafael E. Droz-Seda, P.E.*
10. *Test report on flexural **uplift, lateral, & gravity load** testing on **Concrete Flush Sills**, per ASTM E-529-94, prepared by Hurricane Engineering & Testing, Inc., Report No. **HETI 14-M449**, dated 05/01/14, signed and sealed by Rafael E. Droz-Seda, P.E.*
11. *Test report on flexural **uplift, lateral, & gravity load** testing on **Concrete 3-Step Sills**, per ASTM E-529-94, prepared by Hurricane Engineering & Testing, Inc., Report No. **HETI 14-M387**, dated 04/02/14, signed and sealed by Rafael E. Droz-Seda, P.E.*

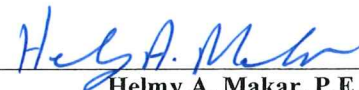

Helmy A. Makar, P.E., M.S.  
Product Control Section Supervisor  
NOA No. 25-0624.03  
Expiration Date: 11/19/2030  
Approval Date: 10/02/2025

**NOTICE OF ACCEPTANCE: EVIDENCE SUBMITTED**

12. *Test report on flexural **uplift, lateral, & gravity load** testing on **Concrete Flush Sills**, per ASTM E-529-94, prepared by Hurricane Engineering & Testing, Inc., Report No. **HETI 14-M372**, dated 02/05/14, signed and sealed by Rafael E. Droz-Seda, P.E.*

**C. CALCULATIONS**

1. *Calculations for Lott's Concrete 8-inch Lintels, dated 03/25/2015, 456 pages, prepared by Florida Engineering Solutions, signed and sealed by John Ashby Hoy, P.E., on 05/20/2015.*

**D. MATERIAL CERTIFICATIONS**

1. *Test report on Compressive Strength of Cylindrical Concrete Specimens, per ASTM C39-14a, prepared by Hurricane Engineering & Testing, Inc., Report No. **HETI 15-C111**, dated 04/27/15, signed and sealed by Rafael E. Droz-Seda, P.E.*
2. *Test report on Compressive Strength of Cylindrical Concrete Specimens, per ASTM C39-14a, prepared by Hurricane Engineering & Testing, Inc., Report No. **HETI 14-C322**, dated 02/10/15, signed and sealed by Rafael E. Droz-Seda, P.E.*
3. *Test report on Compressive Strength of Cylindrical Concrete Specimens, per ASTM C39-14a, prepared by Hurricane Engineering & Testing, Inc., Report No. **HETI 15-C110**, dated 04/27/15, signed and sealed by Rafael E. Droz-Seda, P.E.*
4. *Test report on Compressive Strength of Cylindrical Concrete Specimens, per ASTM C39-14a, prepared by Hurricane Engineering & Testing, Inc., Report No. **HETI 14-C314**, dated 07/01/14, signed and sealed by Rafael E. Droz-Seda, P.E.*
5. *Test report on Compressive Strength of Cylindrical Concrete Specimens, per ASTM C39-12, prepared by Hurricane Engineering & Testing, Inc., Report No. **HETI 14-C313**, dated 06/13/14, signed and sealed by Rafael E. Droz-Seda, P.E.*
6. *Test report on Compressive Strength of Cylindrical Concrete Specimens, per ASTM C39-12, prepared by Hurricane Engineering & Testing, Inc., Report No. **HETI 14-C308**, dated 04/25/14, signed and sealed by Rafael E. Droz-Seda, P.E.*
7. *Test report on Compressive Strength of Cylindrical Concrete Specimens, per ASTM C39-12, prepared by Hurricane Engineering & Testing, Inc., Report No. **HETI 14-C302**, dated 03/18/14, signed and sealed by Rafael E. Droz-Seda, P.E.*
8. *Test report on Compressive Strength of Cylindrical Concrete Specimens, per ASTM C39-12, prepared by Hurricane Engineering & Testing, Inc., Report No. **HETI 14-C304**, dated 04/17/14, signed and sealed by Rafael E. Droz-Seda, P.E.*
9. *Test report on Compressive Strength of Cylindrical Concrete Specimens, per ASTM C39-12, prepared by Hurricane Engineering & Testing, Inc., Report No. **HETI 14-C301**, dated 02/06/14, signed and sealed by Rafael E. Droz-Seda, P.E.*

**E. QUALITY ASSURANCE**

1. *By Miami-Dade County Department of Regulatory and Economic Resources (RER).*

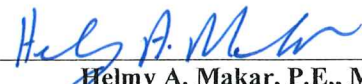

Helmy A. Makar, P.E., M.S.  
Product Control Section Supervisor  
NOA No. 25-0624.03  
Expiration Date: 11/19/2030  
Approval Date: 10/02/2025

**Lott's Concrete Products, Inc.**

**NOTICE OF ACCEPTANCE: EVIDENCE SUBMITTED**

**2. EVIDENCE SUBMITTED UNDER PREVIOUS APPROVAL # 18-0926.03**

**A. DRAWINGS**

1. *Drawing No. SK, titled "Lott's Concrete 8" Lintel Load Tables", sheets 1 through 5 of 5, prepared by Florida Engineering Solutions, Inc., dated Oct. 14, 2017, signed and sealed by John Ashby Hoy, P.E., on Oct. 14, 2017.*

**B. TESTS**

1. *None.*

**C. CALCULATIONS**

1. *None.*

**D. MATERIAL CERTIFICATIONS**

1. *None.*

**E. QUALITY ASSURANCE**

1. *By Miami-Dade County Department of Regulatory and Economic Resources (RER).*

**3. EVIDENCE SUBMITTED UNDER PREVIOUS APPROVAL # 20-1123.04**

**A. DRAWINGS**

1. *Drawing No. SK, titled "Lott's Concrete 8" Lintel Load Tables", sheets 1 through 5 of 5, prepared by Florida Engineering Solutions, Inc., dated Oct. 24, 2020, signed and sealed by John Ashby Hoy, P.E., on Oct. 24, 2020.*

**B. TESTS**

1. *None.*

**C. CALCULATIONS**

1. *None.*

**D. MATERIAL CERTIFICATIONS**

1. *None.*

**E. QUALITY ASSURANCE**

1. *By Miami-Dade County Department of Regulatory and Economic Resources (RER).*

**4. NEW EVIDENCE SUBMITTED**

**A. DRAWINGS**

1. *None.*

**B. TESTS**

1. *None.*

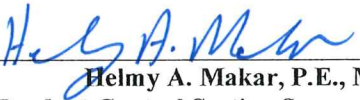
  
\_\_\_\_\_  
Helmy A. Makar, P.E., M.S.  
Product Control Section Supervisor  
NOA No. 25-0624.03  
Expiration Date: 11/19/2030  
Approval Date: 10/02/2025

**Lott's Concrete Products, Inc.**

**NOTICE OF ACCEPTANCE: EVIDENCE SUBMITTED**

**C. CALCULATIONS**

1. *None.*

**D. MATERIAL CERTIFICATIONS**

1. *None.*

**E. QUALITY ASSURANCE**

1. *By Miami-Dade County Department of Regulatory and Economic Resources (RER).*

**F. STATEMENTS**

1. *FBC, 2023 Compliance Letter issued by Florida Engineering Solutions, dated 07/09/25, signed and sealed by John Ashby Hoy, P.E., on July 09, 2025.*



Helmy A. Makar, P.E., M.S.  
Product Control Section Supervisor

NOA No. 25-0624.03

Expiration Date: 11/19/2030

Approval Date: 10/02/2025



# LOTT'S CONCRETE 8" LINTEL LOAD TABLES

SK-1  
10/24/20

Florida Engineering Solutions, Inc. - Certificate of Authorization No. 26300 - P.O. Box 1238, San Antonio, Florida 33576 - Ph: 352/588-5311

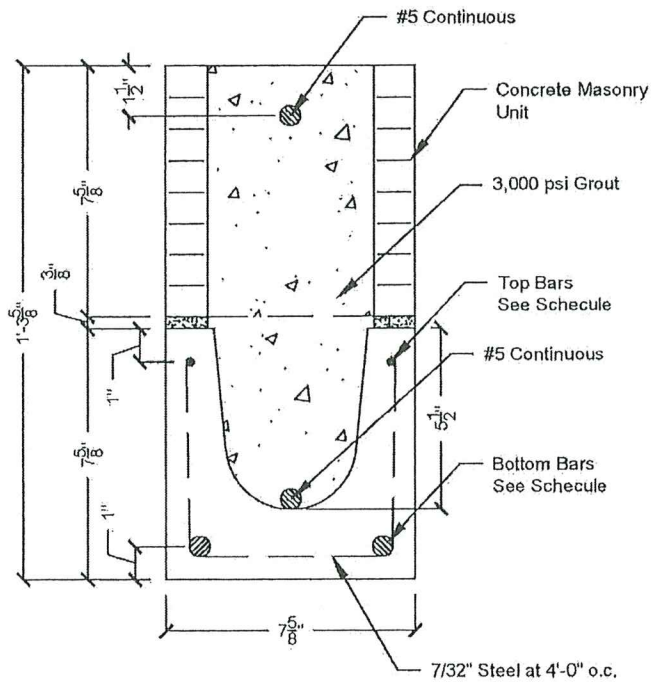

8/16 - S - (1) #5 / (1) #5  
Precast

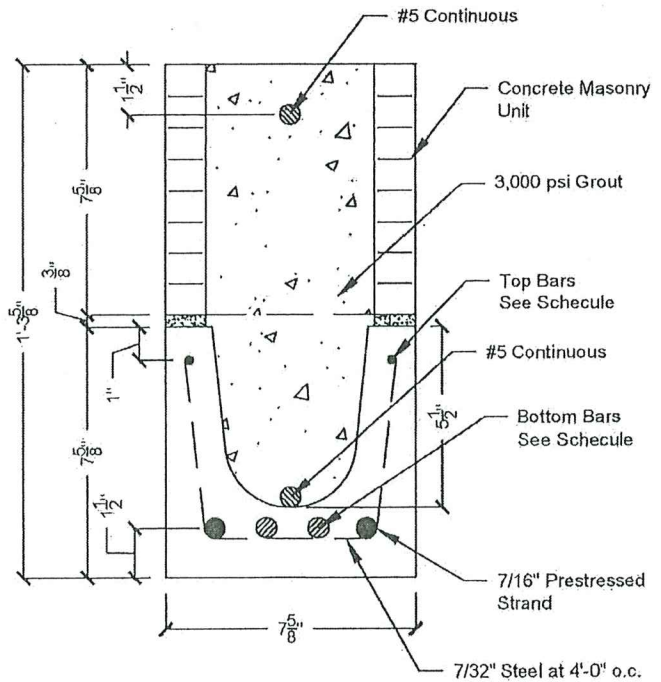

8/16 - S - (1) #5 / (1) #5  
Prestressed

**General Notes:**

**Codes**

- \* Florida Building Code Seventh Edition (2020)
- \* ASCE 7 - 16
- \* ACI 318 - 14
- \* TMS 402 - 16

**Concrete**

- \* Precast Lintels - 4,000 psi
- \* Prestressed Lintels - 6,000 psi
- \* Grout per ASTM C476 - 3,000 psi

**Reinforcement**

- \* Rebar Placed in Precast - ASTM A615 Gr 60
- \* Rebar Placed in Field - ASTM A615 Gr 40
- \* Prestressed Strand - ASTM A416 Gr 270

**Masonry**

- \* Concrete Masonry Units per ASTM C90 - 1900 psi
- \* Mortar per ASTM C270 Type M or S

**Lintels**

- \* Safe Loads Based on a Minimum Bearing of 4"

PRODUCT REVISED  
as complying with the Florida  
Building Code  
Acceptance No 25-0624.03  
Expiration Date 11/19/2030  
By *Hely A. Mohr*  
Miami Dept Product Control

PRODUCT REVISED  
as complying with the Florida  
Building Code  
Acceptance No 20-1123.04  
Expiration Date 11/19/2025  
By *Hely A. Mohr*  
Miami Dept Product Control

*John Hoy, PE*  
Lic 55312  
10/24/20



# LOTT'S CONCRETE 8" LINTEL LOAD TABLES

SK-2  
10/24/20

Florida Engineering Solutions, Inc. - Certificate of Authorization No. 26300 - P.O. Box 1238, San Antonio, Florida 33576 - Ph: 352/588-5311

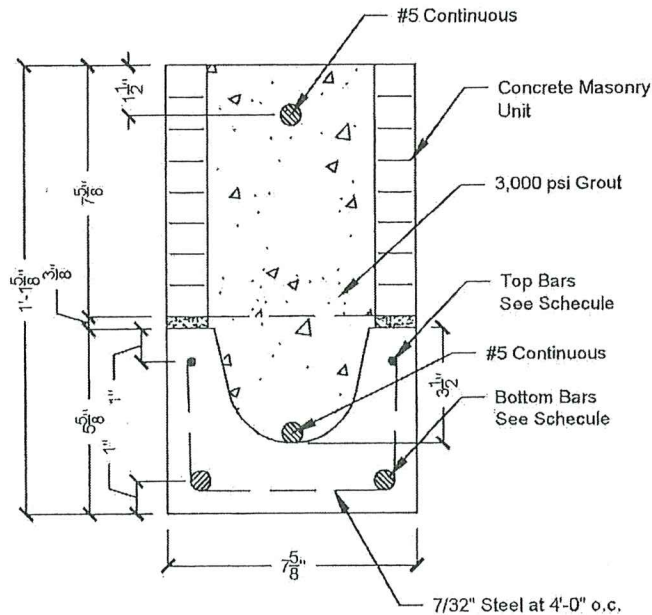

8/14 - S - (1) #5 / (1) #5  
Recess

LINTEL STEEL SCHEDULE			
8 Inch Wide			
LENGTH *	TYPE	Bottom Bar	Top Bar
2'-10" to 4'-8"	PRECAST	(2) #2	(2) #2
5'-4" to 5'-10"	PRECAST	(2) #3	(2) #2
6'-4" to 10'-6"	PRECAST	(2) #4	(2) #2
11'-4" to 14'-0"	PRECAST	(2) #5	(2) #3
14'-8" to 17'-4"	PRESTRESSED	(2) #4	(2) #2
19'-4" to 24'-0"	PRESTRESSED	(2) #5	(2) #3
8 Inch Wide Recess			
3'-8" to 4'-8"	PRECAST	(2) #2	(2) #2
5'-8"	PRECAST	(2) #3	(2) #2
6'-8" to 9'-8"	PRECAST	(2) #4	(2) #2

PRODUCT REVISED  
as complying with the Florida  
Building Code  
Acceptance No. 25-0624-03  
Expiration Date 11/19/2030  
By *Heidi A. Mohr*  
Miami Dade Product Control

PRODUCT REVISED  
as complying with the Florida  
Building Code  
Acceptance No. 20-1123.04  
Expiration Date 11/19/2025  
By *Heidi A. Mohr*  
Miami Dade Product Control

*John Hoy, PE*  
Lic 55312  
10/24/20



LOTT'S CONCRETE  
8" LINTEL LOAD TABLES

SK-3  
10/24/20

Florida Engineering Solutions, Inc. - Certificate of Authorization No. 26300 - P.O. Box 1238, San Antonio, Florida 33576 - Ph: 352/588-5311

8 INCH LINTEL GRAVITY SAFE WORKING LOADS (PLF)										
LENGTH *	TYPE	8/6 PLAIN	8/6-1U/OL	8/8-U/OL	8/14-1U/OL	8/16-1U/OL	8/20-1U/OL	8/24-1U/OL	8/28-1U/OL	8/32-1U/OL
		8/8 PLAIN	8/6-1U/1L	8/8-U/1L	8/14-1U/1L	8/16-1U/1L	8/20-1U/1L	8/24-1U/1L	8/28-1U/1L	8/32-1U/1L
2' 10"	PRECAST	1930	1315	1950	7510	8730	10000	10000	10000	10000
		2829	3257	6099	10000	10000	10000	10000	10000	10000
3' 6"	PRECAST	1189	801	1190	4631	5385	6890	8350	9902	10000
		1746	2184	3712	10000	10000	10000	10000	10000	10000
		879	586	873	3429	3987	5102	6184	7334	8348
4' 0"	PRECAST	1293	1749	2866	7729	8859	10000	10000	10000	10000
		674	444	662	2632	3061	3918	4750	5633	6412
4' 6"	PRECAST	993	1456	2330	5963	6835	7862	9587	10000	10000
		620	406	607	2422	2817	3606	4371	5185	5901
4' 8"	PRECAST	914	1359	2163	5497	6301	7246	8837	10000	10000
		748	926	1465	3566	3482	4472	5425	6414	7404
5' 4"	PRECAST	1063	1136	1773	4310	5809	8882	9082	10000	10000
		659	757	1201	2929	2857	3670	4452	5265	6077
5' 10"	PRECAST	927	1002	1547	3589	4721	7315	7474	8816	10000
		588	895	1371	3070	3971	5863	5807	6866	7925
6' 4"	PRECAST	822	895	1371	3070	3971	6298	10287	10000	10000
		568	863	1319	2925	3766	5536	5482	6482	7482
6' 6"	PRECAST	791	863	1319	2925	3766	5896	9424	10000	10000
		548	834	1271	2793	3581	5235	5182	6128	7073
6' 8"	PRECAST	762	834	1271	2793	3581	5542	8693	10000	10000
		469	713	1078	2284	2882	4060	4013	4745	5478
7' 6"	PRECAST	646	713	1078	2284	2882	4275	6288	8615	7857
		455	693	1046	2201	2770	3868	3821	4518	5216
7' 8"	PRECAST	627	693	1046	2201	2770	4082	5948	8211	7486
		431	656	987	2056	2575	3529	3484	4120	4757
8' 0"	PRECAST	591	656	987	2056	2575	3752	5380	7502	6835
		409	620	926	1927	2405	3232	3188	3770	4353
8' 4"	PRECAST	560	622	934	1927	2405	3469	4908	6878	6264
		353	480	719	1618	1905	2522	2481	2935	3389
9' 4"	PRECAST	481	537	803	1618	2000	2818	3868	5257	4899
		303	366	550	1282	1466	1943	1904	2253	2602
10' 6"	PRECAST	411	462	687	1357	1664	2302	3087	4071	3784
		275	420	622	1215	1484	2033	2694	3501	4506
11' 4"	PRECAST	372	420	622	1215	1484	2033	2694	3501	4506
		256	390	578	1119	1363	1855	2439	3140	3996
12' 0"	PRECAST	346	390	578	1119	1363	1855	2439	3140	3996
		243	371	548	1056	1285	1740	2277	2914	3681
12' 6"	PRECAST	328	371	548	1056	1285	1740	2277	2914	3681
		224	320	494	965	1171	1576	2047	2598	3250
13' 4"	PRECAST	302	342	504	965	1171	1576	2047	2598	3250
		210	285	441	901	1091	1463	1891	2387	2966
14' 0"	PRECAST	283	312	473	901	1091	1463	1891	2387	2966
				479		1079	1429	1824	2277	2801
14' 8"	PRESTRESSED	N.R	N.R		N.R	1079	1429	1824	2277	2801
				438		1014	1340	1703	2118	2593
15' 4"	PRESTRESSED	N.R	N.R		N.R	1014	1340	1703	2118	2593
				328		856	1121	1413	1739	2106
17' 4"	PRESTRESSED	N.R	N.R		N.R	856	1121	1413	1739	2106
				272		736	959	1200	1467	1762
19' 4"	PRESTRESSED	N.R	N.R		N.R	736	959	1200	1467	1762
				272		702	913	1141	1392	1669
20' 0"	PRESTRESSED	N.R	N.R		N.R	702	913	1141	1392	1669
				250		643	833	1038	1261	1506
21' 4"	PRESTRESSED	N.R	N.R		N.R	643	833	1038	1261	1506
				212		616	797	992	1203	1435
22' 0"	PRESTRESSED	N.R	N.R		N.R	616	797	992	1203	1435
				196		534	704	872	1054	1252
24' 0"	PRESTRESSED	N.R	N.R		N.R	534	704	872	1054	1252
				154		546	704	872	1054	1252

\* TOTAL LENGTH OF LINTEL  
N.R - NOT RECOMMENDED

PRODUCT REVISED  
as complying with the Florida  
Building Code  
Acceptance No. 25-0624.03  
Expiration Date 11/19/2030  
By: *Heidi A. M...*  
Miami Dept. Product Control

PRODUCT REVISED  
as complying with the Florida  
Building Code  
Acceptance No. 20-1123.04  
Expiration Date 11/19/2025  
By: *Heidi A. M...*  
Miami Dept. Product Control

John Roy, PE  
Lic 55312  
10/24/20



LOTT'S CONCRETE  
8" LINTEL LOAD TABLES

SK-4

10/24/20

Florida Engineering Solutions, Inc. - Certificate of Authorization No. 26300 - P.O. Box 1238, San Antonio, Florida 33576 - Ph: 352/588-5311

8 INCH LINTEL SAFE WORKING LOADS (PLF)											
		UPLIFT								LATERAL	
LENGTH *	TYPE	8/6-1U	8/8-1U	8/14-1U	8/16-1U	8/20-1U	8/24-1U	8/28-1U	8/32-1U	8/BSPLAIN	8/BSOLID
		8/6-2U	8/8-2U	8/14-2U	8/16-2U	8/20-2U	8/24-2U	8/28-2U	8/32-2U		
2' 10"	PRECAST	2098	3487	10000	10000	10000	10000	10000	10000	2010	2010
		2098	3487	10000	10000	10000	10000	10000	10000		
3' 6"	PRECAST	1457	2220	6360	7428	9578	9578	9578	9578	1250	1250
		1457	2220	10000	10000	10000	10000	10000	10000		
4' 0"	PRECAST	1190	1753	4771	5572	7184	7184	7184	7184	933	933
		1190	1753	7990	10000	10000	10000	10000	10000		
4' 6"	PRECAST	1008	1452	3719	4343	5598	6849	6849	6849	722	722
		1008	1452	5815	8143	10000	10000	10000	10000		
4' 8"	PRECAST	959	1373	3442	4019	5180	6337	6337	6337	667	667
		959	1373	5325	7316	9827	10000	10000	10000		
5' 4"	PRECAST	807	1135	2619	3057	3939	4819	5698	5698	795	795
		807	1135	4021	5259	7441	9169	10000	10000		
5' 10"	PRECAST	722	1005	2183	2548	3282	4014	4746	5480	657	657
		722	1005	3398	4344	6175	7609	9043	10000		
6' 4"	PRECAST	654	903	1849	2160	2782	3401	4021	4643	858	1148
		654	903	2946	3706	5213	6423	7633	8846		
6' 6"	PRECAST	634	873	1755	2049	2639	3226	3814	4404	828	1086
		634	873	2819	3531	4938	6083	7229	8378		
6' 8"	PRECAST	615	846	1667	1947	2507	3065	3623	4183	799	1029
		615	846	2703	3372	4685	5771	6858	7948		
7' 6"	PRECAST	538	733	1327	1548	1993	2436	2879	3323	683	804
		538	733	2255	2769	3695	4552	5408	6266		
7' 8"	PRECAST	525	714	1271	1483	1908	2333	2757	3182	663	767
		525	714	2182	2672	3533	4351	5170	5990		
8' 0"	PRECAST	501	680	1173	1368	1760	2151	2542	2934	628	703
		501	680	2053	2494	3248	4000	4752	5506		
8' 4"	PRECAST	479	649	1086	1267	1630	1992	2354	2717	597	646
		479	649	1939	2302	2998	3692	4385	5081		
9' 4"	PRECAST	394	572	880	1027	1320	1612	1904	2197	510	510
		425	572	1568	1844	2400	2955	3509	4065		
10' 6"	PRECAST	319	473	712	830	1066	1301	1537	1773	400	400
		376	504	1251	1470	1912	2353	2794	3235		
11' 4"	PRECAST	349	466	624	727	933	1138	1344	1550	409	475
		349	466	1084	1274	1656	2037	2418	2800		
12' 0"	PRECAST	330	440	566	659	846	1032	1217	1404	383	422
		330	440	975	1146	1488	1830	2172	2515		
12' 6"	PRECAST	317	422	529	616	790	963	1136	1310	365	388
		317	422	905	1063	1381	1697	2014	2332		
13' 4"	PRECAST	290	396	477	555	711	866	1022	1178	339	340
		298	396	806	946	1229	1510	1791	2073		
14' 0"	PRECAST	267	378	441	513	657	801	944	1088	308	308
		285	378	739	867	1125	1383	1640	1898		
14' 8"	PRESTRESSED	N.R	268		477	611	744	877	1011	N.R	472
		N.R	403	N.R	799	1036	1273	1509	1747		
15' 4"	PRESTRESSED	N.R	250		446	571	695	820	944	N.R	432
		N.R	374	N.R	741	960	1179	1398	1617		
17' 4"	PRESTRESSED	N.R	208		374	478	581	685	788	N.R	336
		N.R	304	N.R	603	781	958	1135	1312		
19' 4"	PRESTRESSED	N.R	234		323	412	501	590	679	N.R	288
		N.R	306	N.R	507	655	803	950	1098		
20' 0"	PRESTRESSED	N.R	222		310	395	480	565	650	N.R	269
		N.R	290	N.R	481	621	761	901	1041		
21' 4"	PRESTRESSED	N.R	202		287	365	443	521	599	N.R	236
		N.R	262	N.R	437	563	690	816	943		
22' 0"	PRESTRESSED	N.R	193		276	352	427	502	578	N.R	221
		N.R	249	N.R	417	538	659	779	900		
24' 0"	PRESTRESSED	N.R	172		251	319	387	455	523	N.R	186
		N.R	219	N.R	369	475	581	687	793		

PRODUCT REVISED  
as complying with the Florida  
Building Code  
Acceptance No 25-0624.03  
Expiration Date 11/19/2030  
By: *W. G. A. M. M.*  
Miami Design Product Control

PRODUCT REVISED  
as complying with the Florida  
Building Code  
Acceptance No 20-1123.04  
Expiration Date 11/19/2025  
By: *W. G. A. M. M.*  
Miami Design Product Control

*John Hoy, PE*  
Lic-55312  
10/24/20



LOTT'S CONCRETE  
8" LINTEL LOAD TABLES

SK-5

10/24/20

Florida Engineering Solutions, Inc. - Certificate of Authorization No. 26300 - P.O. Box 1238, San Antonio, Florida 33576 - Ph: 352/588-5311

**8 INCH RECESS LINTEL SAFE WORKING LOADS (PLF)**

		GRAVITY				UPLIFT		LATERAL	
LENGTH *	TYPE	8/6 PLAIN	8/6-1U/0L	8/14-1U/0L	8/6-1U	8/14-1U	8/6 PLAIN	8/6 SOLID	
			8/6-1U/1L	8/14-1U/1L	8/6-2U	8/14-2U			
3' 8"	PRECAST	981	717	4161	1353	5739	1111	1111	
			2014	9353	1353	10000			
4' 0"	PRECAST	807	586	3429	1190	4771	920	920	
			1749	7729	1190	7990			
4' 2"	PRECAST	735	532	3123	1121	4367	840	840	
			1638	7051	1121	7086			
4' 4"	PRECAST	675	486	2870	1063	4033	774	774	
			1544	6490	1063	6406			
4' 8"	PRECAST	568	406	2422	959	3442	658	658	
			1359	5497	959	5325			
5' 8"	PRECAST	685	806	3113	747	2309	777	915	
			1041	3792	747	3574			
6' 8"	PRECAST	548	834	2793	615	1669	619	992	
			834	2793	615	2703			
7' 8"	PRECAST	455	693	2201	525	1272	514	745	
			693	2201	525	2182			
8' 8"	PRECAST	388	566	1810	452	1009	439	577	
			591	1810	459	1809			
9' 8"	PRECAST	337	443	1533	370	825	384	460	
			513	1533	409	1463			

\* TOTAL LENGTH OF LINTEL

PRODUCT REVISED  
as complying with the Florida  
Building Code  
Acceptance No. 20-0624.03  
Expiration Date 11/19/2030  
By Healy A. Malin  
Miami Dept. Product Control

PRODUCT REVISED  
as complying with the Florida  
Building Code  
Acceptance No. 20-1123.04  
Expiration Date 11/19/2025  
By Healy A. Malin  
Miami Dept. Product Control

John Hoy, PE  
Lic 55312  
10/24/20