



DEPARTMENT OF REGULATORY AND ECONOMIC RESOURCES (RER)
BOARD AND CODE ADMINISTRATION DIVISION

NOTICE OF ACCEPTANCE (NOA)

MIAMI-DADE COUNTY
PRODUCT CONTROL SECTION
11805 SW 26 Street, Room 208
Miami, Florida 33175-2474
T (786) 315-2590 F (786) 315-2599
www.miamidade.gov/economy

The Cookson Company
1901 South Litchfield Road
Goodyear, AZ 85338

SCOPE: This NOA is being issued under the applicable rules and regulations governing the use of construction materials. The documentation submitted has been reviewed and accepted by Miami-Dade County RER-Product Control Section to be used in Miami Dade County and other areas where allowed by the Authority Having Jurisdiction (AHJ).

This NOA shall not be valid after the expiration date stated below. The Miami-Dade County Product Control Section (In Miami Dade County) and/or the AHJ (in areas other than Miami Dade County) reserve the right to have this product or material tested for quality assurance purposes. If this product or material fails to perform in the accepted manner, the manufacturer will incur the expense of such testing and the AHJ may immediately revoke, modify, or suspend the use of such product or material within their jurisdiction. RER reserves the right to revoke this acceptance, if it is determined by Miami-Dade County Product Control Section that this product or material fails to meet the requirements of the applicable building code.

This product is approved as described herein and has been designed to comply with the Florida Building Code, including the High Velocity Hurricane Zone.

DESCRIPTION: Insulated Low-U Steel Rolling Door up to 12ft-5in Wide (50 FPS Impact)

APPROVAL DOCUMENT: Drawing No. **ES-16-127-TCCI**, titled “12’-5” Wide 65 PSF 50 FPS Low-U Insulated Rolling Steel Door”, sheets 1 through 6 of 6, dated 11/10/25, prepared by manufacturer, signed and sealed by Shawn Patrick Kelley, P.E. bearing the Miami-Dade County Product Control Approval stamp with the Notice of Acceptance number and approval date by the Miami-Dade County Product Control Section.

MISSILE IMPACT RATING: Large and Small Missile Impact Resistant

LABELING: Each unit shall bear a permanent label with the manufacturer’s name or logo, one of the two (2) manufacturing addresses on drawings, model number, the positive and negative design pressure rating, indicate impact rated if applicable, installation instruction drawing reference number, approval number (NOA), the applicable test standards, and the statement reading ‘Miami-Dade County Product Control Approved’ is to be located on the door’s side track, bottom angle, or inner surface of a panel.

RENEWAL of this NOA shall be considered after a renewal application has been filed and there has been no change in the applicable building code negatively affecting the performance of this product.

TERMINATION of this NOA will occur after the expiration date or if there has been a revision or change in the materials, use, and/or manufacture of the product or process. Misuse of this NOA as an endorsement of any product, for sales, advertising or any other purposes shall automatically terminate this NOA. Failure to comply with any section of this NOA shall be cause for termination and removal of NOA.

ADVERTISEMENT: The NOA number preceded by the words Miami-Dade County, Florida, and followed by the expiration date may be displayed in advertising literature. If any portion of the NOA is displayed, then it shall be done in its entirety.

INSPECTION: A copy of this entire NOA shall be provided to the user by the manufacturer or its distributors and shall be available for inspection at the job site at the request of the Building Official.

This NOA consists of this page 1 and evidence pages E-1 and E-2, as well as approval document mentioned above.

The submitted documentation was reviewed by **Manuel Perez, P.E.**

6/4/25

NOA No. 25-1022.25
Expiration Date: June 11, 2031
Approval Date: June 11, 2026
Page 1

The Cookson Company

NOTICE OF ACCEPTANCE: EVIDENCE SUBMITTED

A. DRAWINGS

1. Manufacturer's die drawings and sections.
(Submitted under NOA No. 25-1022.03)
2. Drawing No. **ES-16-127-TCCI**, titled "12'-5" Wide 60 PSF 50 FPS Low-U Insulated Rolling Steel Door", sheets 1 through 6 of 6, dated 11/10/25, prepared by manufacturer, signed and sealed by Shawn Patrick Kelley, P.E.

B. TESTS

1. Test reports on: 1) Uniform Static Air Pressure Test, Loading per FBC, TAS 202-94
2) Large Missile Impact Test per FBC, TAS 201-94
3) Cyclic Wind Pressure Loading per FBC, TAS 203-94
4) Forced Entry Test, per FBC, TAS 202-94
along with marked-up drawings and installation diagram of Insulated/Thermiser Rolling Garage Door 12'-4" wide x 10' high, prepared by Intertek, Test Report No. **Q9397.11-109-18 R2**, dated 05/28/25, with revision dated 06/26/25, signed and sealed by Tanya A. Dolby, P.E.

C. CALCULATIONS

1. Calculations prepared by Moment Engineering+ Design, LLC, dated 05/20/25 and 05/21/25, signed and sealed by Shawn Patrick Kelley, P.E.

D. QUALITY ASSURANCE

1. Miami-Dade Department of Regulatory and Economic Resources (RER)

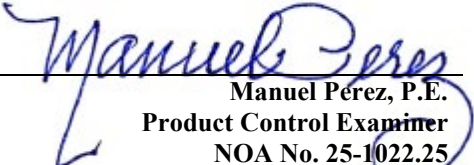
Manuel Pérez, P.E.
Product Control Examiner
NOA No. 25-1022.25
Expiration Date: June 11, 2031
Approval Date: June 11, 2026

NOTICE OF ACCEPTANCE: EVIDENCE SUBMITTED

E. MATERIAL CERTIFICATIONS

1. Test report on Salt Spray Performance per ASTM B117-19 of G90 unpainted and G40 painted samples, prepared by Intertek, Test Report No. **M6278.01-106-18 R0**, dated 12/13/21, signed and sealed by Vinu J. Abraham, P.E.
2. Test report on Tensile Strength per ASTM E8-24 of sheet metal samples, prepared by Intertek, Test Report No. **S3387.01-106-18 R1**, dated 04/01/25, signed and sealed by Tanya A. Dolby, P.E.
3. Test Report on Flame Spread/ Smoke Density per ASTM E84 of Thermiser polyurethane foam, prepared by Intertek, Report No. **N5858.01-121-18-R0**, dated 07/14/22, signed and sealed by Tanya A. Dolby, P.E.
4. Test Report on Ignition Temperature per ASTM D1929 of Thermiser polyurethane foam, prepared by Intertek, Report No. **N5873.01-106-18-R0**, dated 06/08/22, signed and sealed by Vinu J. Abraham, P.E.
5. Test Report on Ignition Temperature per ASTM D1929 and Rate of Burning per ASTM D635 of Thermiser Low-U ESD 40, prepared by Intertek, Report No. **T6282.01-106-18-R0**, dated 05/05/26, signed and sealed by Tanya A. Dolby, P.E.
6. Rockwool ProRox SL 940 mineral wool insulation technical specifications.

F. STATEMENTS

1. Statement letter of conformance, complying with **FBC 8th Edition (2023)** and of no financial interest, dated June 11, 2025, prepared and issued by Moment Engineering+ Design, LLC, signed and sealed by Shawn Patrick Kelley, P.E.
2. Private Labeling Agreement between Clopay Corporation, and The Cookson Company, dated 10/01/25, signed by Siva Davuluri and Edward M Shin, respectively.

G. OTHERS

1. None.



Manuel Pérez, P.E.
Product Control Examiner
NOA No. 25-1022.25
Expiration Date: June 11, 2031
Approval Date: June 11, 2026

The following pages in this document were submitted by the manufacturer (third party) to represent the product being approved and establish the limits of use. The pages may include technical drawings, schematics and installation details.

L'TR	REVISION	DATE	BY	E.C.O.
*	ORIGINAL ISSUE	11/10/2025	KAD	2400

HOOD
#24 GA. MINIMUM
GALVANIZED OR
STAINLESS STEEL

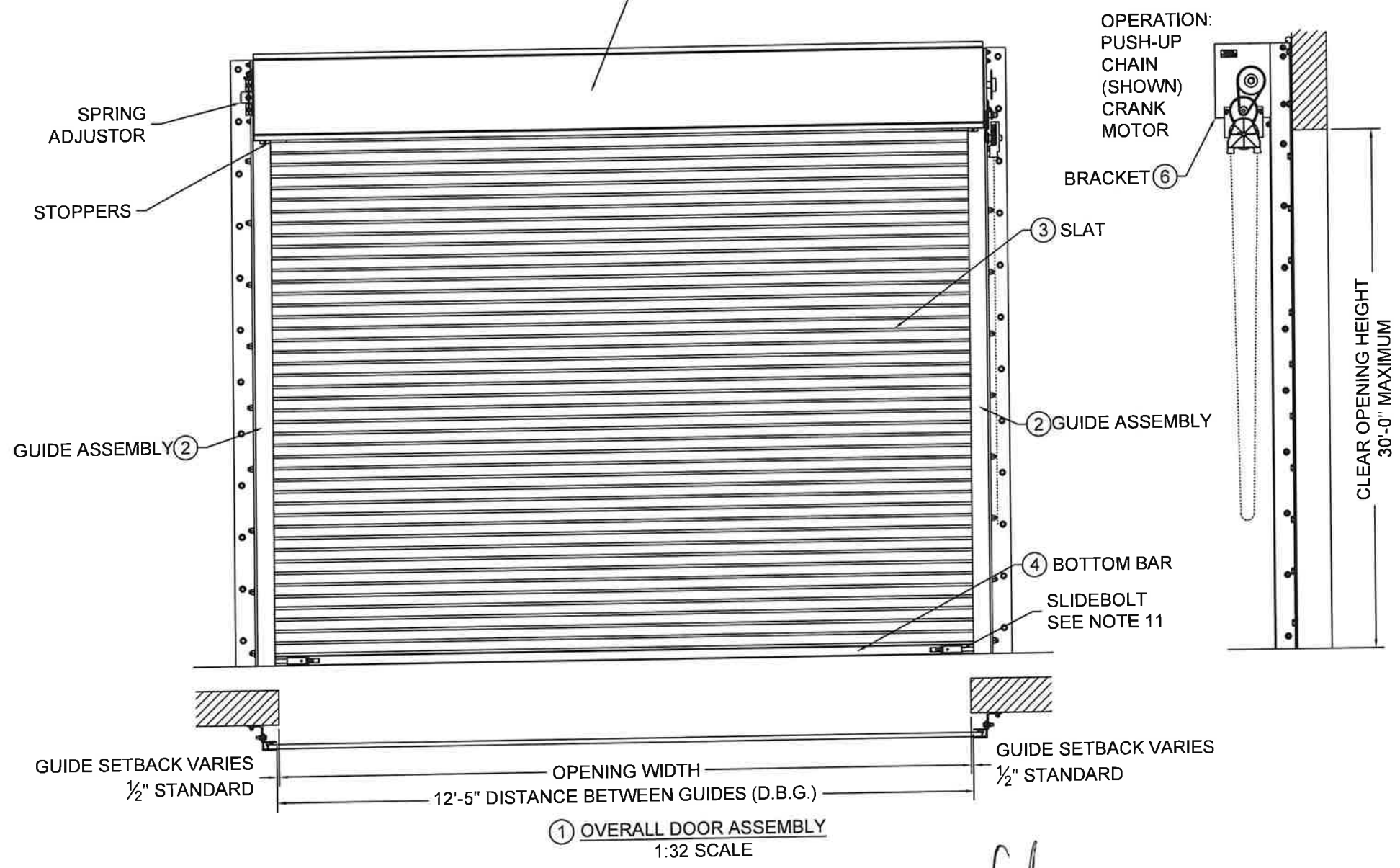
ROLL-UP MECHANISM NOT INCLUDED IN THIS
APPROVAL. MUST BE CERTIFIED BY AN
INDEPENDENT TESTING AGENCY IF REQUIRED.



- NOTES:
- THIS ROLL-UP DOOR SYSTEM IS DESIGNED IN ACCORDANCE WITH THE FLORIDA BUILDING CODE, AS A LARGE MISSILE IMPACT RESISTANT SYSTEM.
 - POSITIVE AND NEGATIVE DESIGN PRESSURE CALCULATIONS SHALL BE PERFORMED FOR SPECIFIC JOBS IN ACCORDANCE WITH ASCE 7 *MINIMUM DESIGN LOADS FOR BUILDINGS AND OTHER STRUCTURES*. WIND LOADS DETERMINED FOR OPENINGS SHALL BE LESS THAN OR EQUAL TO DOOR DESIGN PRESSURES NOTED BELOW.
POSITIVE DESIGN LOAD = 60 PSF
NEGATIVE DESIGN LOAD = 60 PSF
 - THE DETAILS AND SPECIFICATIONS SHOWN HEREIN REPRESENT THE PRODUCTS TESTED FOR UNIFORM STATIC AIR PRESSURE IN CONFORMANCE WITH DADE COUNTY PROTOCOLS TAS 201, 202 AND 203.
 - TESTING PERFORMED BY INTERTEK (YORK, PENNSYLVANIA) TEST REPORT No. q9397.11-109-18.
 - SUPERIMPOSED LOADS ON THE JAMBS FROM THIS DOOR ARE DESIGNATED AS F1, F2, AND F3 HEREIN. CONTRACTORS SHALL HAVE FLORIDA REGISTERED PROFESSIONAL ENGINEER VERIFY ADEQUACY OF BUILDING STRUCTURE TO RESIST SUPERIMPOSED LOAD F1, F2, AND F3.
 - ALL WELDING SHALL BE PERFORMED BY QUALIFIED WELDERS IN ACCORDANCE WITH AWS SPECIFICATIONS, LATEST EDITION. ALL WELDING ELECTRODES SHALL CONFORM TO AWS A5.1, GRADE E-70. MINIMUM WELDING PROCESS SHALL BE ARC WELDING AWS E7014 OR MIG WELDING AWS ER70S-6.
 - ANCHOR NOTES:
A. EMBEDMENT DEPTH DOES NOT INCLUDE STUCCO FINISH.
B. ANCHORS SHALL BE INSTALLED IN ACCORDANCE WITH MANUFACTURERS SPECIFICATIONS.
 - MINERAL WOOL INSULATION AND AN OVERALL U-FACTOR RATING OF 0.532.
 - DOOR MAY BE INSTALLED ON THE INSIDE OF AN EXTERIOR WALL.
 - A 33% INCREASE IN ALLOWABLE STRESS HAS NOT BEEN USED IN THE DESIGN OF THIS PRODUCT.
 - SLIDE BOLTS ARE NOT REQUIRED FOR WINDLOAD RESISTANCE. SLIDE BOLTS ARE ONLY REQUIRED ON PUSH UP OPERATED UNITS FOR FORCED ENTRY RESISTANCE. LOCKING IS TO BE PROVIDED BY OTHERS OR AS CYLINDER LOCKS BY THE COOKSON COMPANY.
 - ENDLOCK/WINDLOCKS ARE SECURED TO EACH END OF ALTERNATING SLATS WITH THREE 1/4" RIVETS PER END RESULTING IN ALTERNATING SLAT WINDLOCK SUPPORT.
 - GUIDE ASSEMBLY AND BOTTOM BAR ARE TO BE PROTECTED FROM CORROSION WITH POLYESTER POWDER COATING WHEN NOT MINIMUM G90 GALVANIZED STEEL OR STAINLESS STEEL.

① OVERALL DOOR ASSEMBLY
1:32 SCALE

PRODUCT APPROVED
As complying with the Florida
Building Code
NOA-No. **25-1022.25**
Approval Date: **06/11/2026**
By: *Manuel Perez*
Miami-Dade Product Control



4/21/26

	24 ELMWOOD AVE 1901 S. LITCHFIELD RD MOUNTAINTOP, PA GOODYEAR, AZ	Unless otherwise specified, dimensions are in inches & tolerances are: 0.000 = +/- 0.031 FRACTIONAL = +/- 1/32 ANGLES = +/- 1/2 DEG
	P: 800.390.8590 F: 866.448.6798 E: ADS@COOKSONDOOR.COM	TITLE: MIAMI DADE COUNTY APPROVED 12'-5" WIDE 60 PSF 50 FPS LOW-U INSULATED ROLLING STEEL DOOR

L'TR	REVISION	DATE	BY	E.C.O.
*	ORIGINAL ISSUE	11/10/2025	KAD	2400

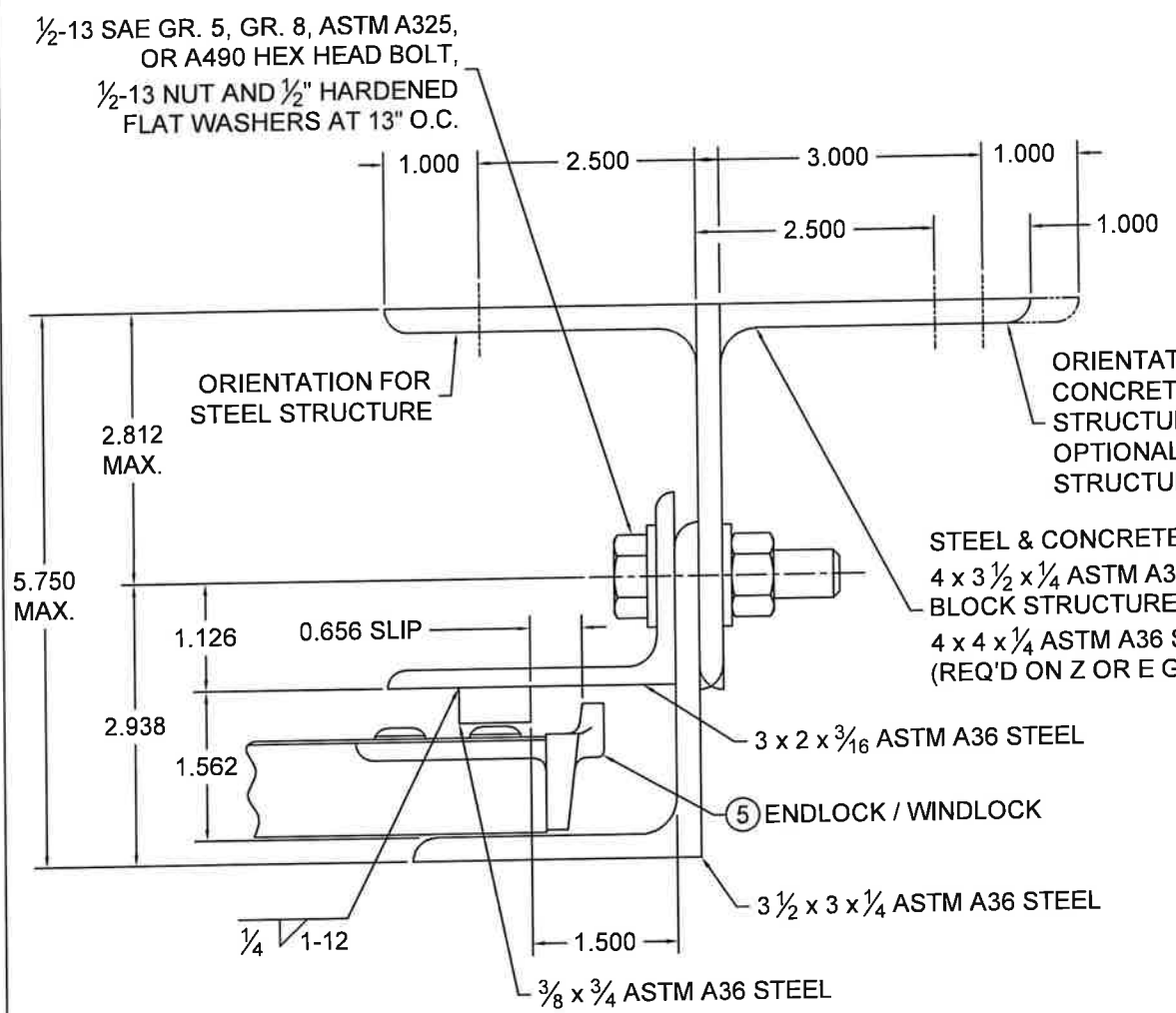

② GUIDE ASSEMBLY DETAIL
1:2 SCALE

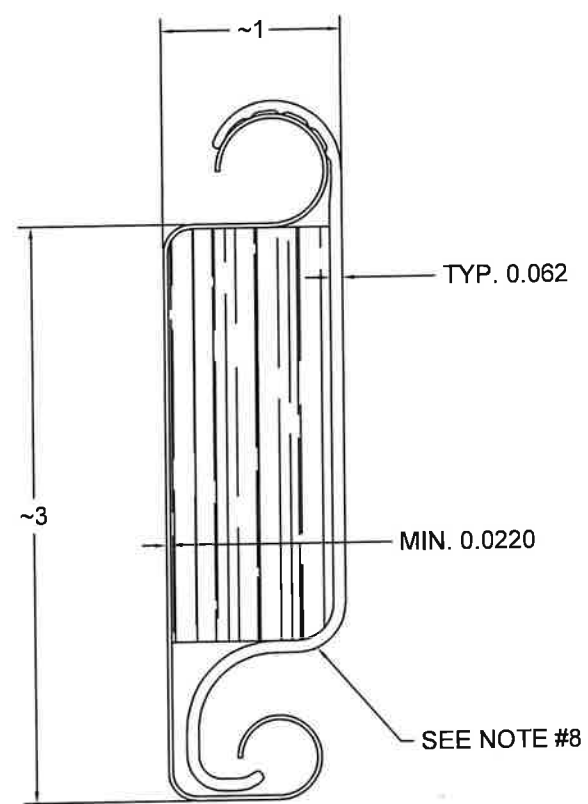

③ SLAT DETAIL
TYPICAL SECTION
FRONT SLAT:

ASTM A653 HSLAS TYPE B GRADE 40 G40 WITH POLYESTER BASED COATING OR
 ASTM A653 HSLAS TYPE A GRADE 40 G40 WITH POLYESTER BASED COATING OR
 ASTM A653 STRUCTURAL STEEL GRADE 40 G40 WITH POLYESTER BASED COATING
 OR TYPE 304 STAINLESS STEEL (MIN. YIELD 40,000 psi)
 OR TYPE 316 STAINLESS STEEL (MIN. YIELD 40,000 psi)
 OR TYPE 430 STAINLESS STEEL (MIN. YIELD 40,000 psi)
 OR TYPE 201 STAINLESS STEEL (MIN. YIELD 40,000 psi)
 BACK SLAT:
 CHLORINATED POLYVINYL CHLORIDE, LOW-SMOKE
 FULL SCALE

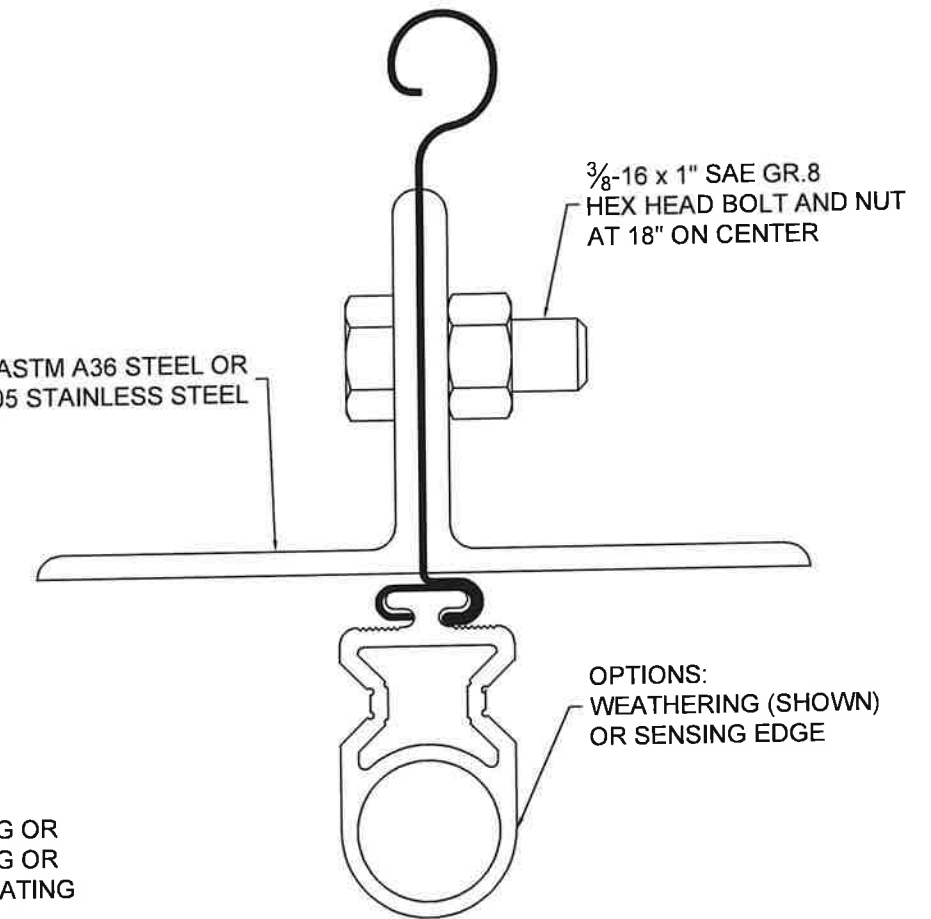

④ BOTTOM BAR DETAIL
TYPICAL SECTION
FULL SCALE

PRODUCT APPROVED
 As complying with the Florida
 Building Code
 NOA-No. **25-1022.25**
 Approval Date: **06/11/2026**
 By: *Manuel Perez*
 Miami-Dade Product Control



4/21/26

	24 ELMWOOD AVE 1901 S. LITCHFIELD RD MOUNTAINTOP, PA GOODYEAR, AZ	Unless otherwise specified, dimensions are in inches & tolerances are: 0.000 = +/- 0.031 FRACTIONAL = +/- 1/32 ANGLES = +/- 1/2 DEG		
	P: 800.390.8590 F: 866.448.6798 E: ADS@COOKSONDOOR.COM	DRAWN BY: KAD	SIZE: B	SCALE: AS NOTED
TITLE: MIAMI DADE COUNTY APPROVED 12'-5" WIDE 60 PSF 50 FPS LOW-U INSULATED ROLLING STEEL DOOR		DWG NO: ES-16-127-TCCI		

L'TR	REVISION	DATE	BY	E.C.O.
*	ORIGINAL ISSUE	11/10/2025	KAD	2400

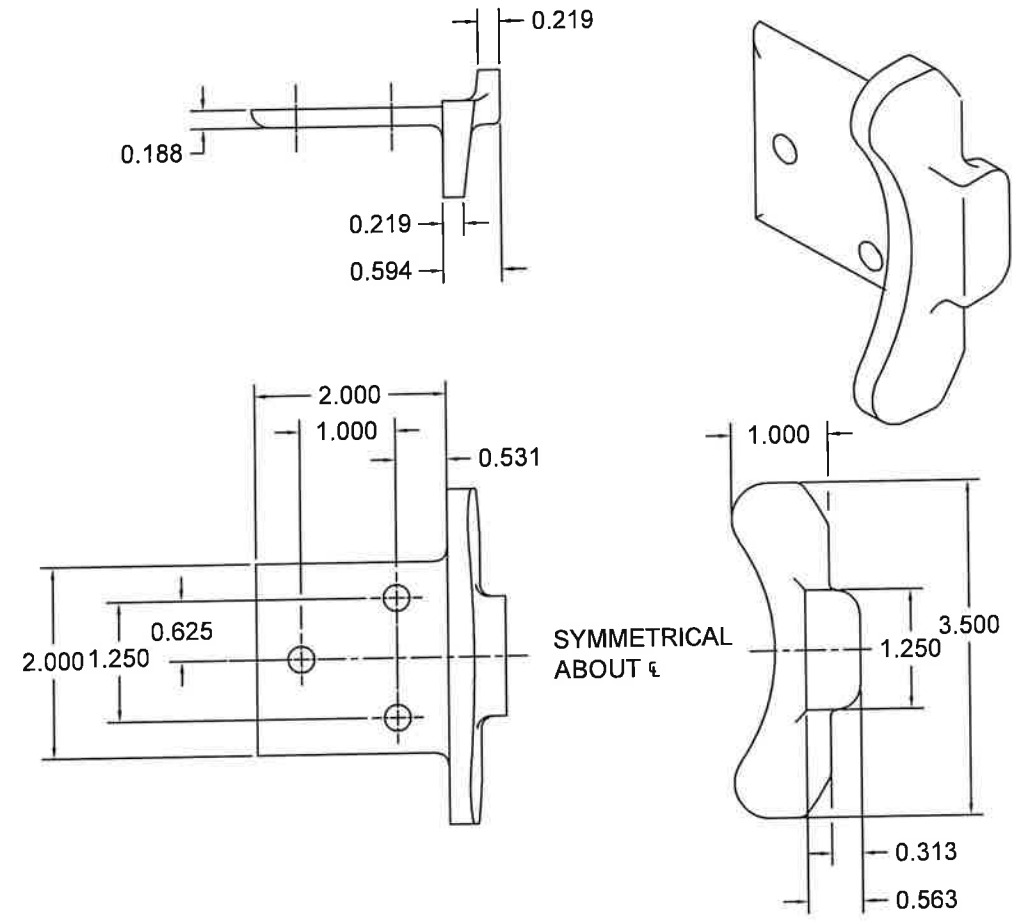

⑤ ENDLOCK / WINDLOCK DETAIL
 CAST MALLEABLE IRON ASTM A47, GRADE 32510, OR
 DUCTILE IRON PER ASTM A536 GRADE 65-45-12, GALVANIZED IN ACCORDANCE WITH
 ASTM A123, GRADE 85 ZINC-COATING
 1/2 SCALE

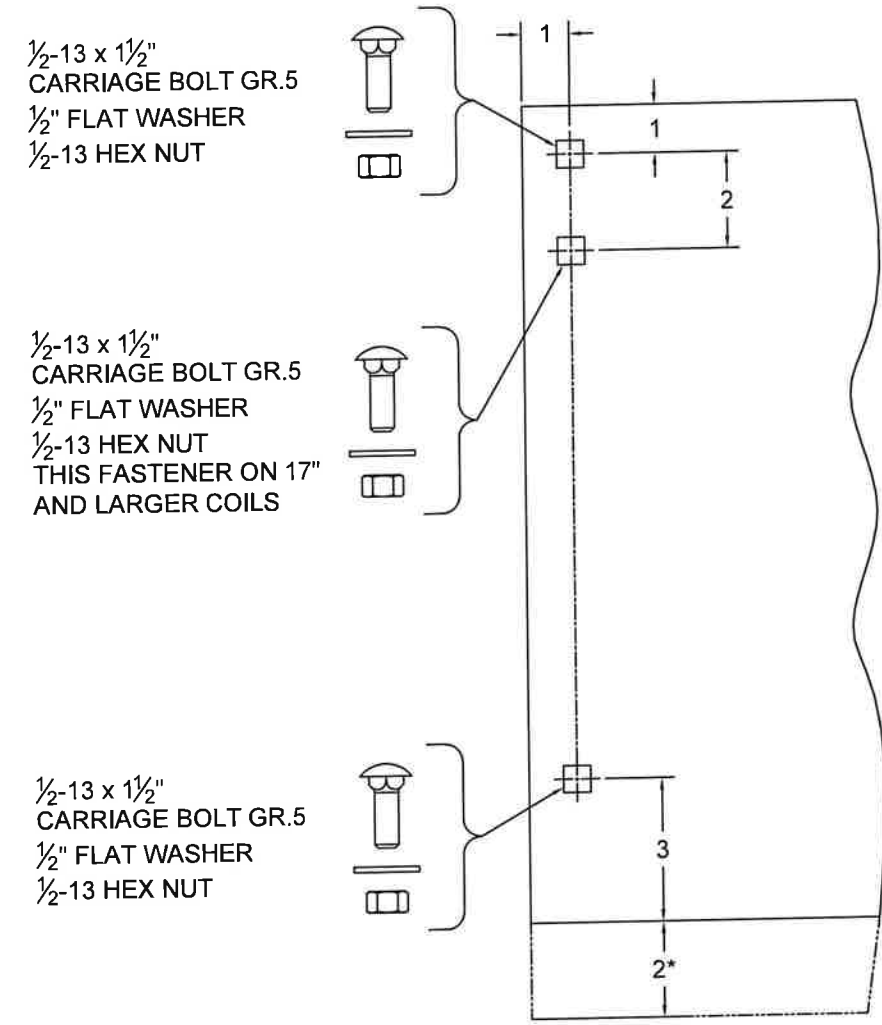

⑥ BRACKET MOUNTING DETAIL
 0.172 MIN. THICKNESS
 * 2" EXTENSION WHEN 8" AND LARGER SHAFT ASSEMBLY IS SUPPLIED
 1/4 SCALE

PRODUCT APPROVED
 As complying with the Florida
 Building Code
 NOA-No. **25-1022.25**
 Approval Date: **06/11/2026**
 By: *Manuel Perez*
 Miami-Dade Product Control



4/21/26

	24 ELMWOOD AVE 1901 S. LITCHFIELD RD MOUNTAINTOP, PA GOODYEAR, AZ		Unless otherwise specified, dimensions are in inches & tolerances are: 0.000 = +/- 0.031 FRACTIONAL = +/- 1/32 ANGLES = +/- 1/2 DEG		
	P: 800.390.8590 F: 866.448.6798 E: ADS@COOKSONDOOR.COM				
TITLE: MIAMI DADE COUNTY APPROVED 12'-5" WIDE 60 PSF 50 FPS LOW-U INSULATED ROLLING STEEL DOOR		DRAWN BY: KAD	SIZE: B	SCALE: AS NOTED	SHEET: 3/6
		DWG NO: ES-16-127-TCCI			

CONCRETE FASTENERS (4000PSI STRENGTH)				
FASTENER	TYPE	DIAMETER (IN)	MIN. EMBEDMENT (IN)	SPACING (IN)
SIMPSON STRONG-BOLT 2	CARBON STEEL	1/2	3 7/8	10
HILTI KWIK-BOLT 1			3 5/8	8
POWERS POWER-STUD+ SD1			3 3/4	9
HILTI KWIK-BOLT TZ2			3 3/4	8
HILTI KH-EZ			4 1/4	17
REDHEAD TRUBOLT			4	11
HILTI HVU2			4 1/4	15
SIMPSON STRONG-BOLT 2			STAINLESS STEEL	1/2
HILTI KWIK-BOLT TZ2	3 3/4	9		
HILTI KH-EZ	4 1/4	9		
SIMPSON TITEN HD	4	7		
THROUGH BOLTING	SAE GR5, SAE GR8, ASTM A325, OR ASTM A490	-	-	35
	316 STAINLESS STEEL	-	-	16

L'TR	REVISION	DATE	BY	E.C.O.
*	ORIGINAL ISSUE	11/10/2025	KAD	2400

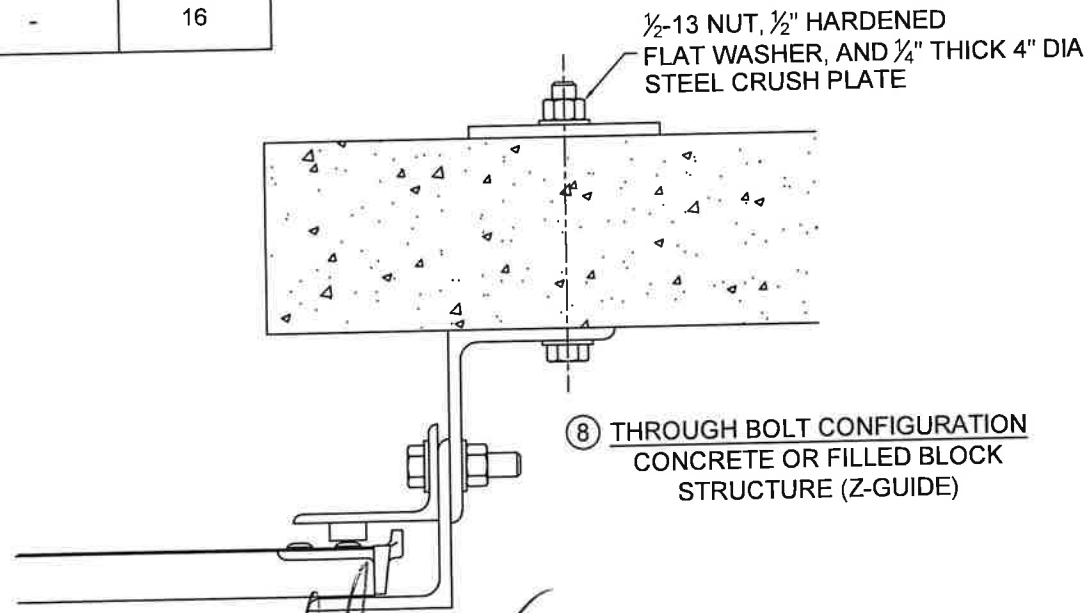
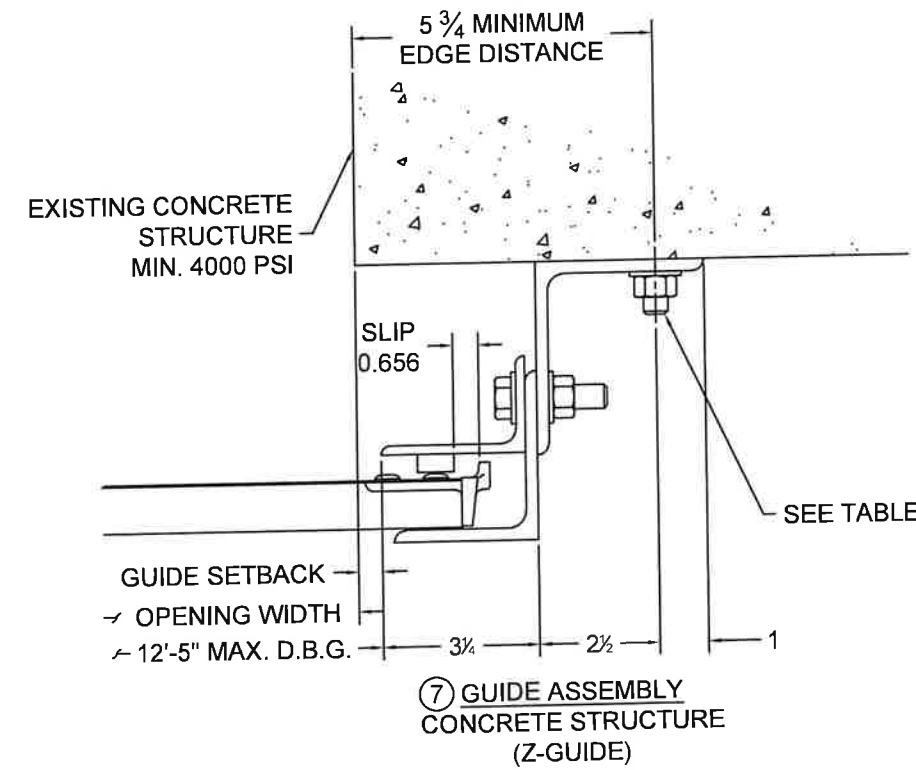
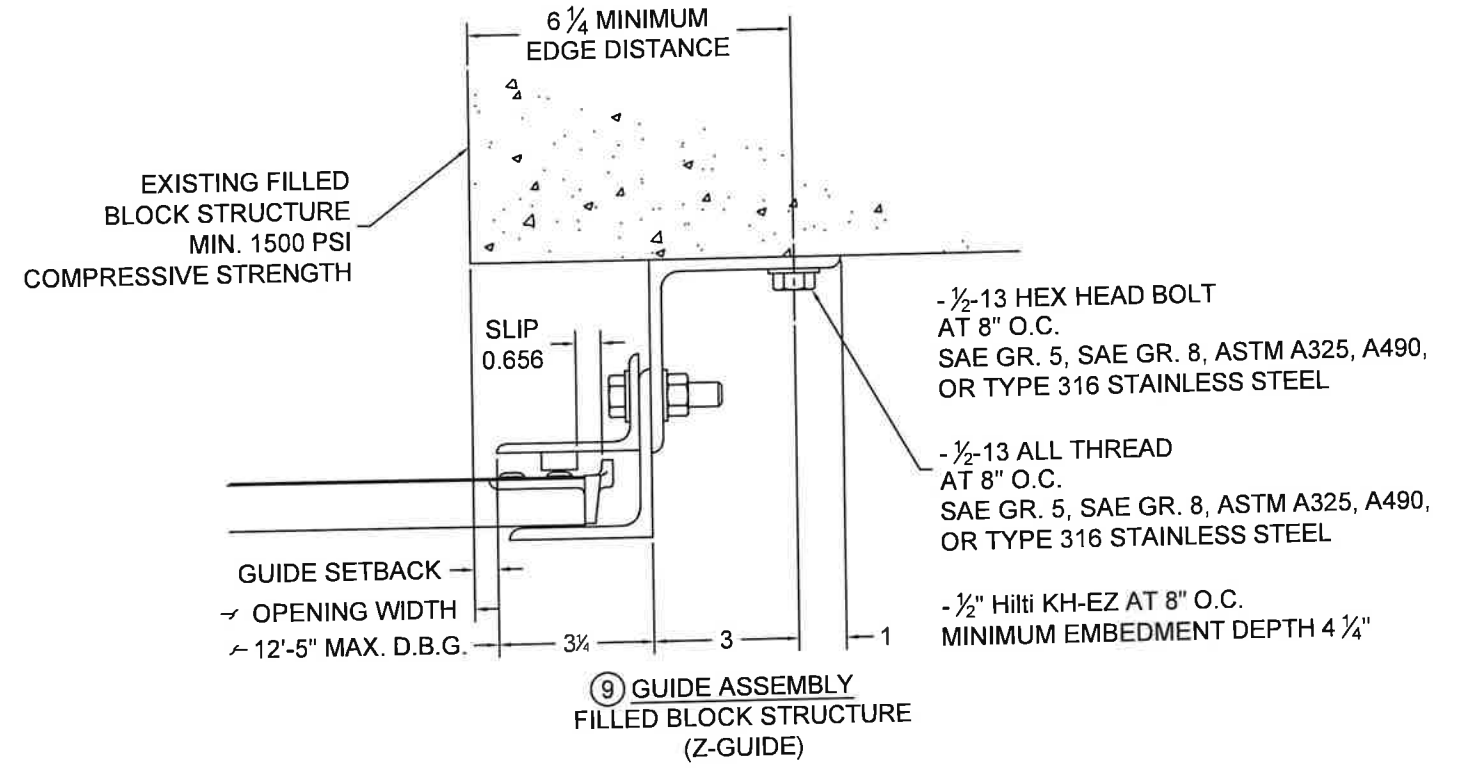

PRODUCT APPROVED
 As complying with the Florida Building Code
 NOA-No. **25-1022.25**
 Approval Date: **06/11/2026**
 By: *Manuel Perez*
 Miami-Dade Product Control

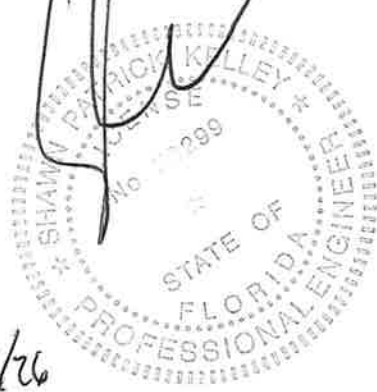

Preferred door solutions.

COOKSON

24 ELMWOOD AVE 1901 S. LITCHFIELD RD
 MOUNTAINTOP, PA GOODYEAR, AZ

P: 800.390.8590
 F: 866.448.6798
 E: ADS@COOKSONDOOR.COM

Unless otherwise specified, dimensions are in inches & tolerances are:

0.000 = +/- 0.031
 FRACTIONAL = +/- 1/32
 ANGLES = +/- 1/2 DEG

TITLE: **MIAMI DADE COUNTY APPROVED 12'-5" WIDE 60 PSF 50 FPS LOW-U INSULATED ROLLING STEEL DOOR**

DRAWN BY: **KAD** SIZE: **B** SCALE: **AS NOTED** SHEET: **4/6**

DWG NO: **ES-16-127-TCCI**

4/21/26

L'TR	REVISION	DATE	BY	E.C.O.
*	ORIGINAL ISSUE	11/10/2025	KAD	2400

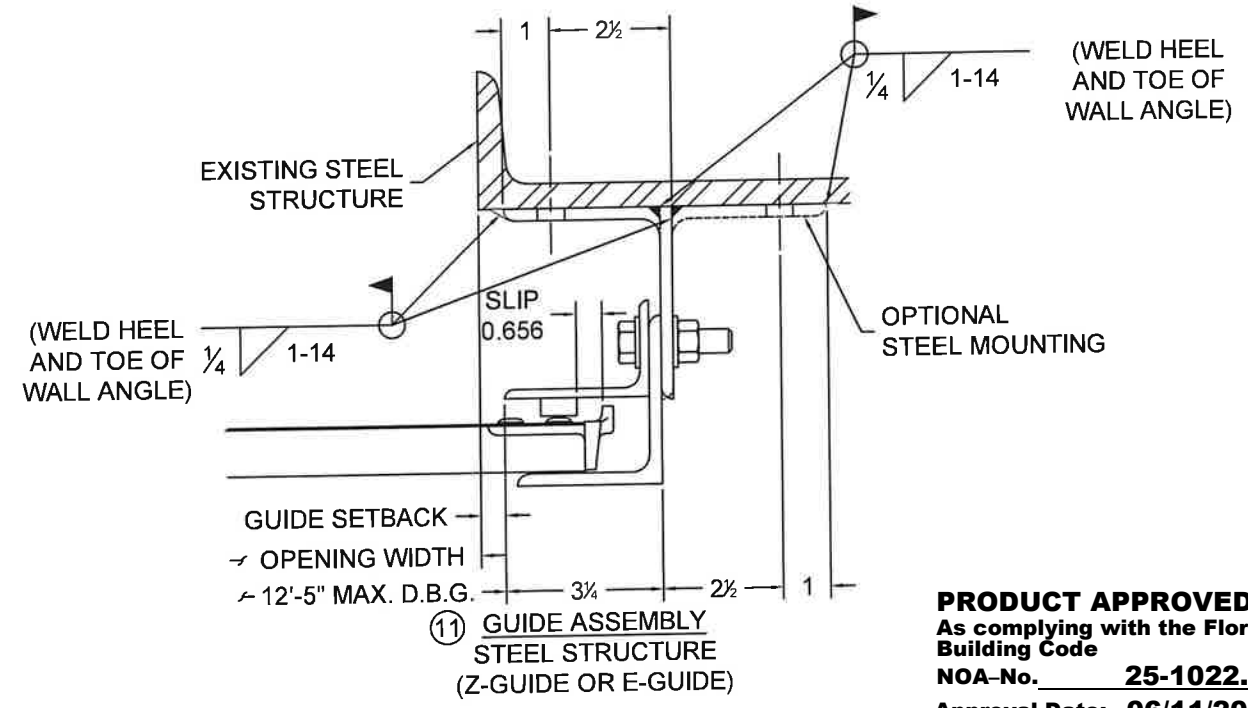
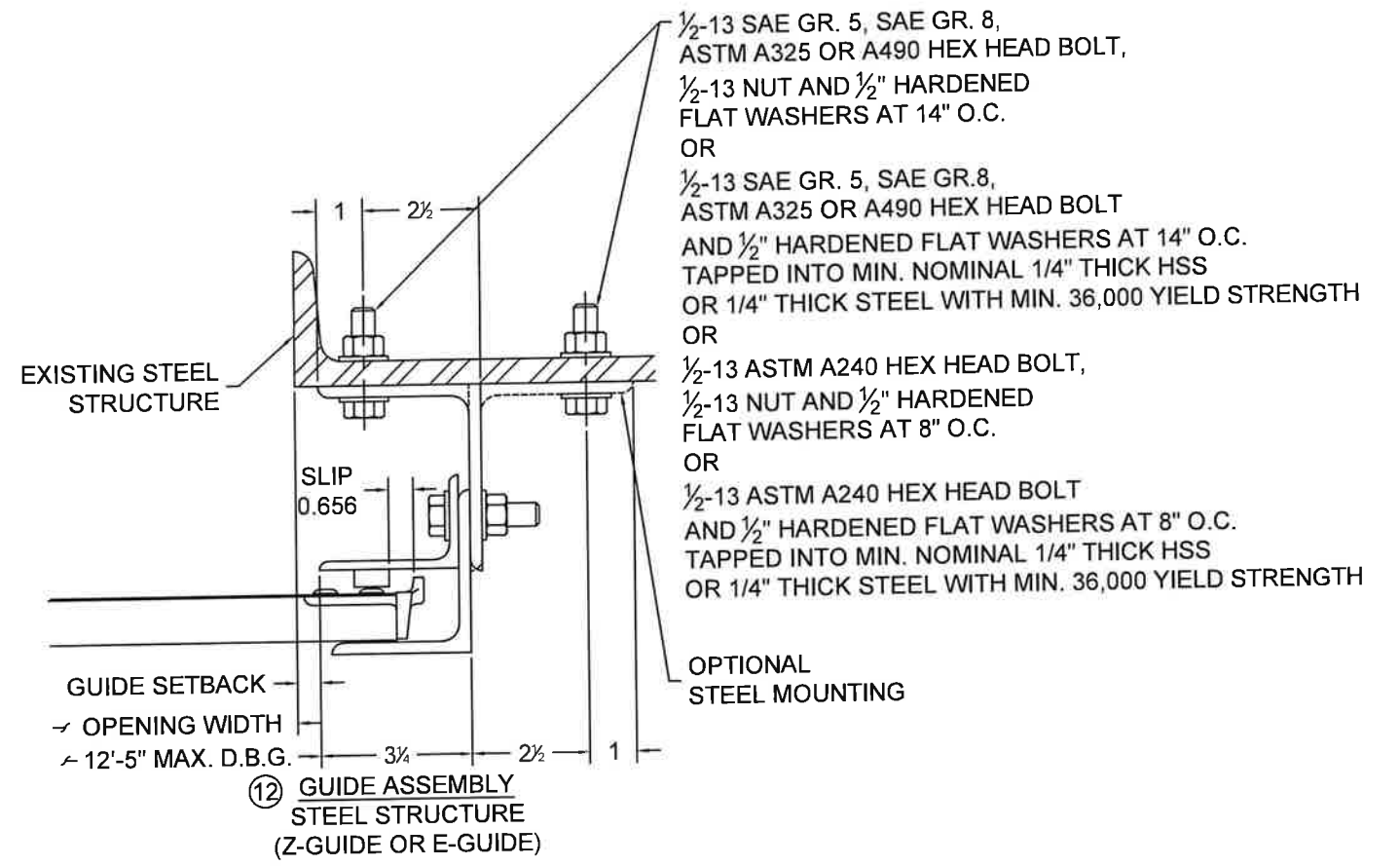
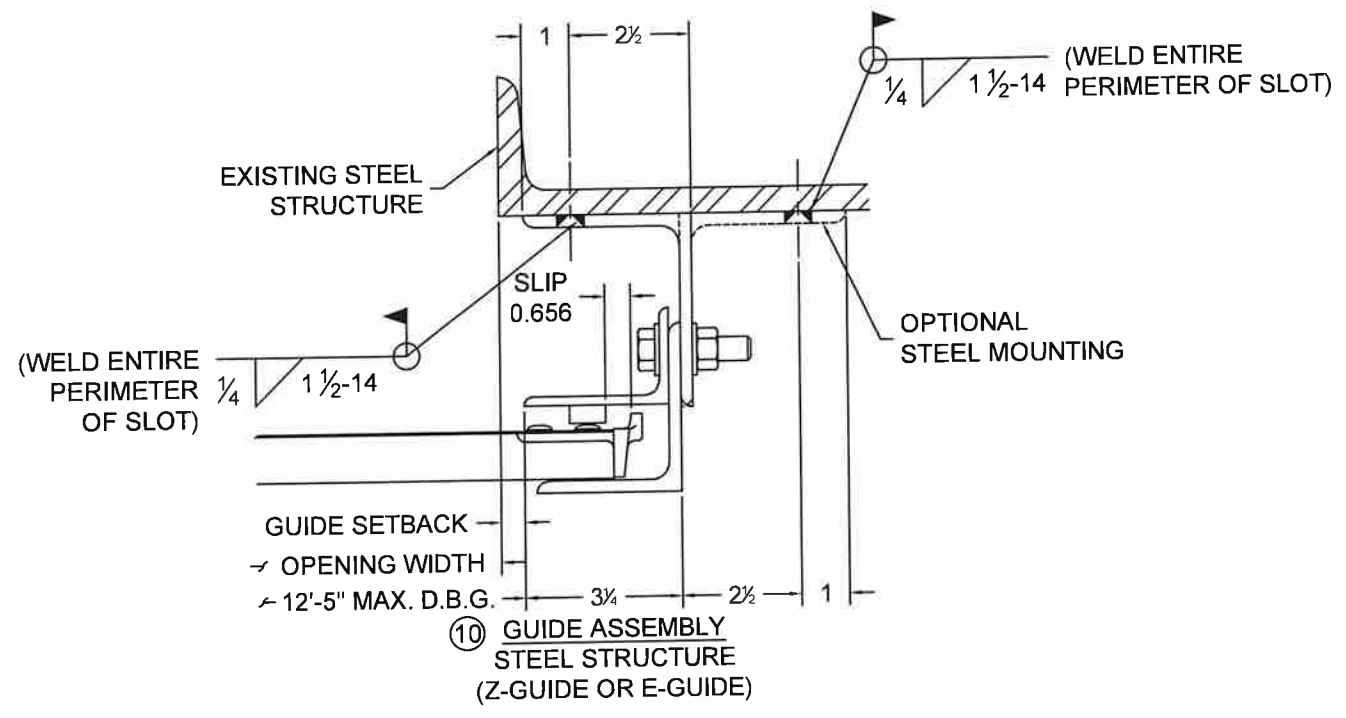

PRODUCT APPROVED
As complying with the Florida Building Code
NOA-No. **25-1022.25**
Approval Date: **06/11/2026**
By: *Manuel Perez*
Miami-Dade Product Control

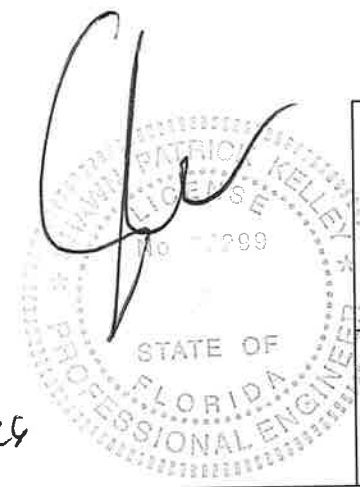

	24 ELMWOOD AVE 1901 S. LITCHFIELD RD MOUNTAINTOP, PA GOODYEAR, AZ P: 800.390.8590 F: 866.448.6798 E: ADS@COOKSONDOOR.COM	Unless otherwise specified, dimensions are in inches & tolerances are: 0.000 = +/- 0.031 FRACTIONAL = +/- 1/32 ANGLES = +/- 1/2 DEG
	TITLE: MIAMI DADE COUNTY APPROVED 12'-5" WIDE 60 PSF 50 FPS LOW-U INSULATED ROLLING STEEL DOOR	DRAWN BY: KAD SIZE: B SCALE: AS NOTED SHEET: 5/6

4/25/25

L'TR	REVISION	DATE	BY	E.C.O.
*	ORIGINAL ISSUE	11/10/2025	KAD	2400

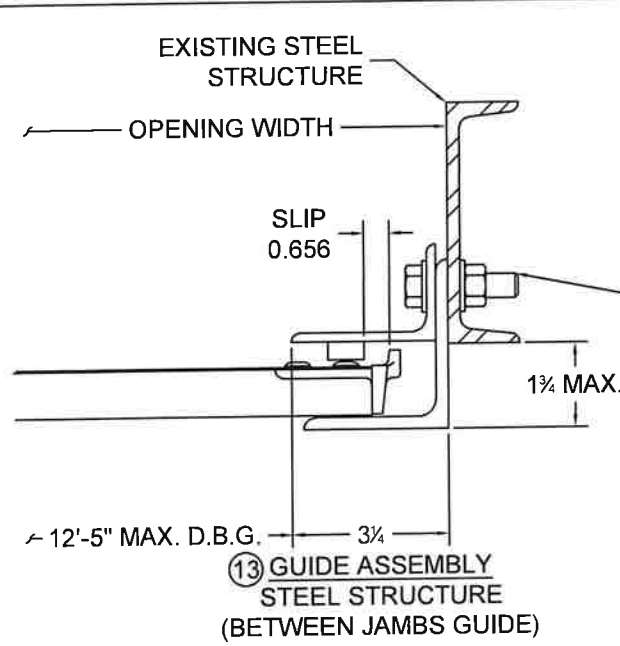

$\frac{1}{2}$ -13 SAE GR. 5, SAE GR. 8,
 ASTM A325 OR A490 HEX HEAD BOLT,
 $\frac{1}{2}$ -13 NUT AND $\frac{1}{2}$ " HARDENED
 FLAT WASHERS AT 14" O.C.
 OR
 $\frac{1}{2}$ -13 SAE GR. 5, SAE GR.8,
 ASTM A325 OR A490 HEX HEAD BOLT
 AND $\frac{1}{2}$ " HARDENED FLAT WASHERS AT 14" O.C.
 TAPPED INTO MIN. NOMINAL $\frac{1}{4}$ " THICK HSS
 OR $\frac{1}{4}$ " THICK STEEL WITH MIN. 36,000 YIELD STRENGTH
 OR
 $\frac{1}{2}$ -13 ASTM A240 HEX HEAD BOLT,
 $\frac{1}{2}$ -13 NUT AND $\frac{1}{2}$ " HARDENED
 FLAT WASHERS AT 6" O.C.
 OR
 $\frac{1}{2}$ -13 ASTM A240 HEX HEAD BOLT
 AND $\frac{1}{2}$ " HARDENED FLAT WASHERS AT 6" O.C.
 TAPPED INTO MIN. NOMINAL $\frac{1}{4}$ " THICK HSS
 OR $\frac{1}{4}$ " THICK STEEL WITH MIN. 36,000 YIELD STRENGTH

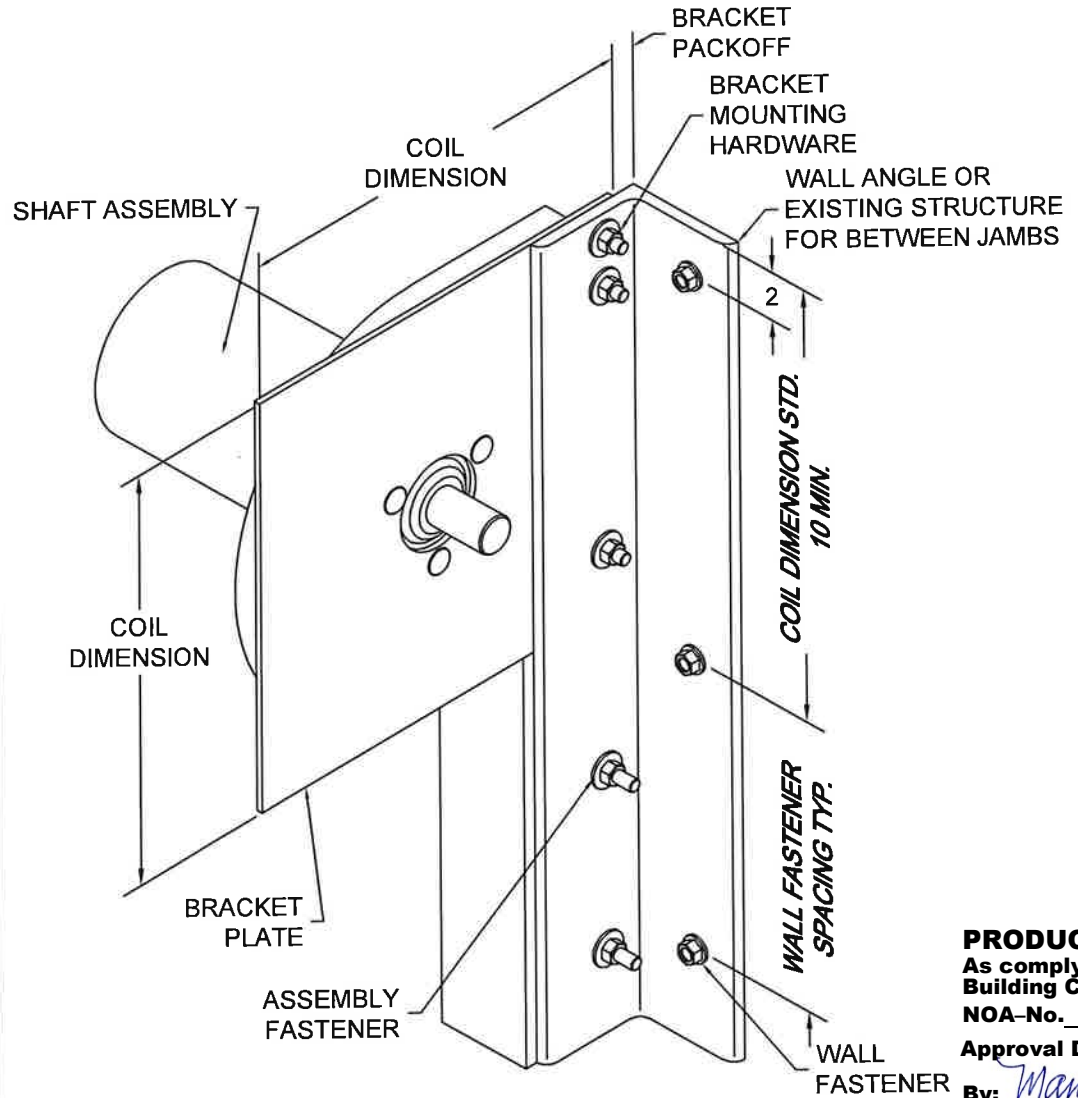
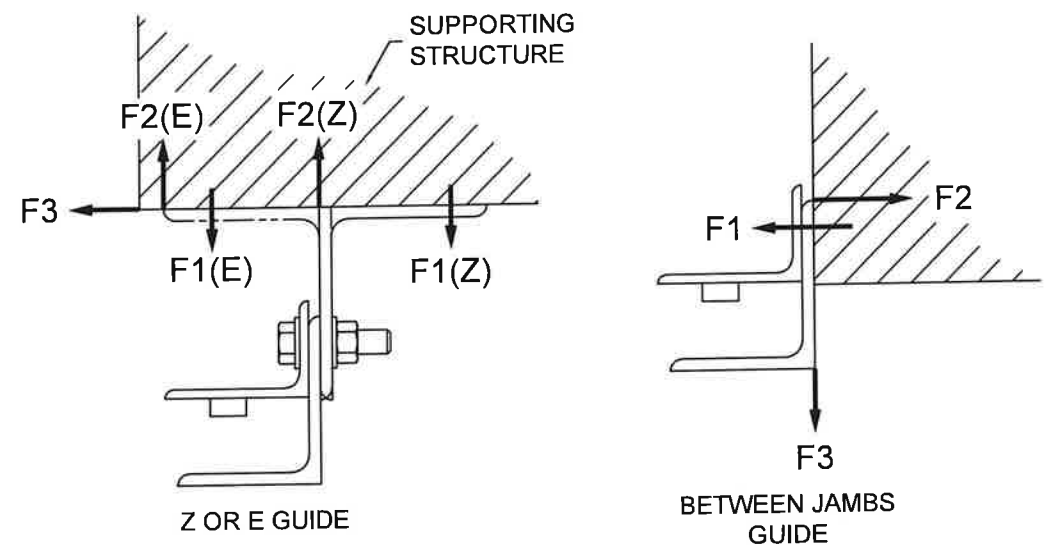

UNREDUCED WIND FORCES ON BUILDING STRUCTURE (LBS / FOOT OF HEIGHT)

Z-GUIDE					
POSITIVE			NEGATIVE		
F1	F2	F3	F1	F2	F3
1314	934	1061	2210	2590	1061
E-GUIDE					
POSITIVE			NEGATIVE		
F1	F2	F3	F1	F2	F3
4519	4139	1061	4290	4670	1061
BETWEEN JAMBS GUIDE					
POSITIVE			NEGATIVE		
F1	F2	F3	F1	F2	F3
2372	1311	380	5579	4518	380

BUILDING DESIGNER NOTE:
 STRUCTURE MUST BE DESIGNED TO SUPPORT F1, F2, AND F3 FORCES (LBS./FT. OF OPENING HEIGHT) AT EACH JAMB.

14 BRACKET MOUNTING / TOP WALL ANGLE FASTENING
 BRACKET MOUNTING PER DETAIL 6 DEPICTED,
 OTHER BRACKET MOUNTINGS ARE AVAILABLE
 SCALE: NTS

PRODUCT APPROVED
 As complying with the Florida
 Building Code
 NOA-No. **25-1022.25**
 Approval Date: **06/11/2026**
 By: *Manuel Perez*
 Miami-Dade Product Control



4/21/26

24 ELMWOOD AVE 1901 S. LITCHFIELD RD
 MOUNTAINTOP, PA GOODYEAR, AZ

P: 800.390.8590
 F: 866.448.6798
 E: ADS@COOKSONDOOR.COM

Preferred door solutions.

COOKSON

Unless otherwise specified,
 dimensions are in inches &
 tolerances are:

0.000 = +/- 0.031
 FRACTIONAL = +/- 1/32
 ANGLES = +/- 1/2 DEG

TITLE: **MIAMI DADE COUNTY APPROVED
 12'-5" WIDE 60 PSF 50 FPS LOW-U
 INSULATED ROLLING STEEL DOOR**

DRAWN BY: **KAD** SIZE: **B** SCALE: **AS NOTED** SHEET: **6/6**

DWG NO: **ES-16-127-TCCI**