



DEPARTMENT OF REGULATORY AND ECONOMIC RESOURCES (RER)
BOARD AND CODE ADMINISTRATION DIVISION

MIAMI-DADE COUNTY
PRODUCT CONTROL SECTION

11805 SW 26 Street, Room 208
Miami, Florida 33175-2474
T (786) 315-2590 F (786) 315-2599

www.miamidade.gov/economy

NOTICE OF ACCEPTANCE (NOA)

Santafe Tile Corporation
8825 NW 95th Street
Medley, FL 33178

SCOPE:

This NOA is being issued under the applicable rules and regulations governing the use of construction materials. The documentation submitted has been reviewed and accepted by Miami-Dade County RER - Product Control Section to be used in Miami-Dade County and other areas where allowed by the Authority Having Jurisdiction (AHJ).

This NOA shall not be valid after the expiration date stated below. The Miami-Dade County Product Control Section (in Miami-Dade County) and/or the AHJ (in areas other than Miami-Dade County) reserve the right to have this product or material tested for quality assurance purposes. If this product or material fails to perform in the accepted manner, the manufacturer will incur the expense of such testing and the AHJ may immediately revoke, modify, or suspend the use of such product or material within their jurisdiction. RER reserves the right to revoke this acceptance, if it is determined by Miami-Dade County Product Control Section that this product or material fails to meet the requirements of the applicable building code.

This product is approved as described herein, and has been designed to comply with the Florida Building Code including the High Velocity Hurricane Zone of the Florida Building Code.

DESCRIPTION: Santafe Spanish 'S' Clay Roof Tile

LABELING: Each unit shall bear a permanent label with the manufacturer's name or logo, city, state and following statement: "Miami-Dade County Product Control Approved", unless otherwise noted herein.

RENEWAL of this NOA shall be considered after a renewal application has been filed and there has been no change in the applicable building code negatively affecting the performance of this product.

TERMINATION of this NOA will occur after the expiration date or if there has been a revision or change in the materials, use, and/or manufacture of the product or process. Misuse of this NOA as an endorsement of any product, for sales, advertising or any other purposes shall automatically terminate this NOA. Failure to comply with any section of this NOA shall be cause for termination and removal of NOA.

ADVERTISEMENT: The NOA number preceded by the words Miami-Dade County, Florida, and followed by the expiration date may be displayed in advertising literature. If any portion of the NOA is displayed, then it shall be done in its entirety.

INSPECTION: A copy of this entire NOA shall be provided to the user by the manufacturer or its distributors and shall be available for inspection at the job site at the request of the Building Official.

This NOA renews NOA# 21-0614.05 and consists of pages 1 through 6.
The submitted documentation was reviewed by Alex Tigera.

12/24/25



NOA No.: 25-1120.01
Expiration Date: 02/01/31
Approval Date: 12/24/25
Page 1 of 6

ROOFING ASSEMBLY APPROVAL

<u>Category:</u>	Roofing
<u>Sub-Category:</u>	Roofing Tiles
<u>Material:</u>	Clay
<u>Deck Type:</u>	Wood

1. SCOPE

This approves a roofing system using Santa Fe “Santafe ‘S’” Clay Roof Tile, as manufactured by Ladrillera Santafe S.A. in Bogota, Colombia and distributed by Santafe Tile Corporation as described in Section 2 of this Notice of Acceptance. For locations where the pressure requirements, as determined by applicable Building Code, do not exceed the design pressure values obtained by calculations in compliance with RAS 127 using the values listed in section 4 herein. The attachment calculations shall be done as a moment based system.

2. PRODUCT DESCRIPTION

<u>Manufactured by Applicant</u>	<u>Dimensions</u>	<u>Test Specifications</u>	<u>Product Description</u>
Santafé ‘S’ Clay Roof Tile	L = 18” W = 11.1” Thickness = 0.39”	TAS 112 Type I Grade 1	One piece high profile clay roof tile equipped with two nail holes. For nail-on, batten (4/12 min slope); and mortar set and adhesive set applications.
Trim Pieces	l = varies w = varies varying thickness	TAS 112	Accessory trim, clay roof pieces for use at hips, rakes, ridges and valley terminations. Manufactured for each tile profile.

2.1 MANUFACTURING LOCATION

1. Bogota, Colombia

2.2 PRODUCTS MANUFACTURED BY OTHERS

<u>Product Name</u>	<u>Product Description</u>	<u>Manufacturer (With Current NOA)</u>
APOC® Polyset® AH-160 (HFC)	Two component polyurethane foam adhesive.	ICP Construction, Inc.
APOC® Polyset® AH-160 (HFO1)	Two component polyurethane foam adhesive.	ICP Construction, Inc.
TILE BOND™ Roof Tile Adhesive	Single component polyurethane foam roof tile adhesive.	DuPont de Nemours, Inc.
DAP StormBond® 2 Roof Tile Adhesive	Two component polyurethane foam adhesive.	DAP Global, Inc.



2.3 SUBMITTED EVIDENCE

<u>Test Agency</u>	<u>Test Identifier</u>	<u>Test Name/Report</u>	<u>Date</u>
The Center for Applied Engineering, Inc.	94-156-8	TAS 101	Aug. 1994
	94-156-9	TAS 102	
	25-7205-1	TAS 101	March 1995
	Project: 07-07-00-91 (307023)	TAS 100	Sept. 1994
Redland Technologies	7161-03	TAS 108	Dec. 1991
	Appendix II	(Nail-On)	
	7161-03	Static Uplift Testing	Dec. 1991
	Appendix III	TAS 102 & TAS 102(A)	
	P 0402	Withdrawal Resistance	Sept. 1993
		Testing of Screw vs smooth shank nails	
	P 0647-01	TAS 108	Aug. 1994
		(Mortar Set)	
	P 0631-01	PA 108	July. 1994
		(Mortar Set)	
Celotex Corporation Testing Services	520305-01 thru 05	PA 102	June 1999
PRI Asphalt Technologies, Inc.	SFTC-003-02-01	TAS 101	12/06/02
IBA Consultants, Inc.	2353-70	TAS 101	09/22/03
	2353-71	TAS 101	09/22/03
	2353-93	ASTM C 1167	07/18/05
	2353-4	Restoring Moment	Aug. 1999
American Test Lab of South Florida	RT0624.01-15	ASTM C1167-03	07/01/15
	RT1008.01-20	ASTM C1167	10/16/20
	RT0919.01-25	ASTM C1167	09/30/25
PRI Construction Material Technologies	COPO-002-02-08	TAS 101	10/12/16



3. LIMITATIONS

- 3.1 Fire classification is not part of this acceptance.
- 3.2 For mortar or adhesive set tile applications, a static field uplift test shall be performed in accordance with TAS 106.
- 3.3 Applicant shall retain the services of a Miami-Dade County Certified Laboratory to perform quarterly test in accordance with TAS 112, appendix 'A'. Such testing shall be submitted to the Miami-Dade County Product Control Section for review.
- 3.4 Minimum underlayment shall be in compliance with the applicable Roofing Applications Standards listed section 4.1 herein.
- 3.5 Mechanically attached tile; minimum slope 4/12.
- 3.6 30/90 hot mopped underlayment applications may be installed perpendicular to the roof slope unless stated otherwise by the underlayment material manufacturers published literature.
- 3.7 This acceptance is for wood deck applications. Minimum deck requirements shall be in compliance with applicable building code.
- 3.8 May be installed on slopes 7:12 and greater.

4. INSTALLATION

- 4.1 Santafe 'S' and its components shall be installed in strict compliance with Roofing Application Standard RAS 118, RAS 119 and RAS 120.
- 4.2 Data For Attachment Calculations

Table 1: Average Weight (W) and Dimensions (l x w)			
Tile Profile	Weight-W (lbf)	Length-l (ft)	Width-w (ft)
Santafe 'S'	6.7	1.5	0.958

Table 2: Aerodynamic Multipliers– $\lambda(\text{ft}^3)$		
Tile Profile	$\lambda(\text{ft}^3)$ Batten Application	$\lambda(\text{ft}^3)$ Direct Deck
Santafe 'S'	0.274	0.297

Table 3: Restoring Moments due to Gravity - $M_g(\text{ft.-lbf})$												
Tile Profile	2":12"		3":12"		4":12"		5":12"		6":12"		7":12" or greater	
	Battens	Direct Deck	Battens	Direct Deck	Battens	Direct Deck	Battens	Direct Deck	Battens	Direct Deck	Battens	Direct Deck
Santafe 'S'	N/A	5.90	N/A	5.82	5.73	5.69	5.56	5.53	5.32	5.29	5.03	5.00



**Table 4: Attachment Resistance Expressed as a Moment - M_f (ft.-lbf)
for Nail-On Systems**

Tile Profile	Fastener Type	Direct Deck	Battens
Santafe 'S'	2-10d Ring Shank Nails	21.8	N/A
	One #8 Screw	29.16 ^{1,2}	N/A
	Two #8 Screws	38.28 ¹	N/A
	One #8 Screw w/ Clip	57.31 ^{1,2}	N/A
	Two #8 Screws w/ Clip	57.60 ¹	61.77 ¹

1. Approved screws as noted 'Product manufactured by others'.
2. When using one screw it must be installed in the inside hole located nearest to the hump of the tile.

**Table 5: Attachment Resistance Expressed as a Moment M_f (ft.-lbf)
for Two Patty Adhesive³ Set Systems**

Tile Profile: Santafe 'S'			
Tile Application	Paddy weight	Adhesive Contact Area	Minimum Attachment Resistance
TILE BOND™ Roof Tile Adhesive – (Independent)	10.4 grams each	-	38.9
APOC® Polyset® AH-160 (HFC & HFO1)	9.4 grams each	-	33.1

3. See manufacturer component approval for installation requirements.

**Table 6: Attachment Resistance Expressed as a Moment - M_f (ft.-lbf)
for Single Patty Adhesive⁴ Set Systems**

Tile Profile: Santafe 'S'			
Tile Application	Paddy weight	Adhesive Contact Area	Minimum Attachment Resistance
APOC® Polyset® AH-160 (HFC & HFO1)	63 grams each	-	66.5
APOC® Polyset® AH-160 (HFC & HFO1)	24 grams each	-	63.8
DAP StormBond® 2 Roof Tile Adhesive	45 grams each	-	100

4. See manufacturer component approval for installation requirements.

**Table 7: Attachment Resistance Expressed as a Moment - M_f (ft.-lbf)
for Mortar or Adhesive Set Systems**

Tile Profile	Tile Application	Attachment Resistance
Santafe 'S'	Mortar Set	23.6



5. LABELING

5.1 All tiles shall bear the imprint or identifiable marking of the manufacturer's name or logo as shown below, or following statement: "Miami-Dade County Product Control Approved".

SANTA FE TM MADE IN COLOMBIA

LABEL FOR SANTA FE SPANISH "S" CLAY ROOF TILE

6. BUILDING PERMIT REQUIREMENTS

6.1 Application for building permit shall be accompanied by copies of the following:

6.1.1 This Notice of Acceptance.

6.1.2 Any other documents required by the Building Official or applicable building code in order to properly evaluate the installation of this system.

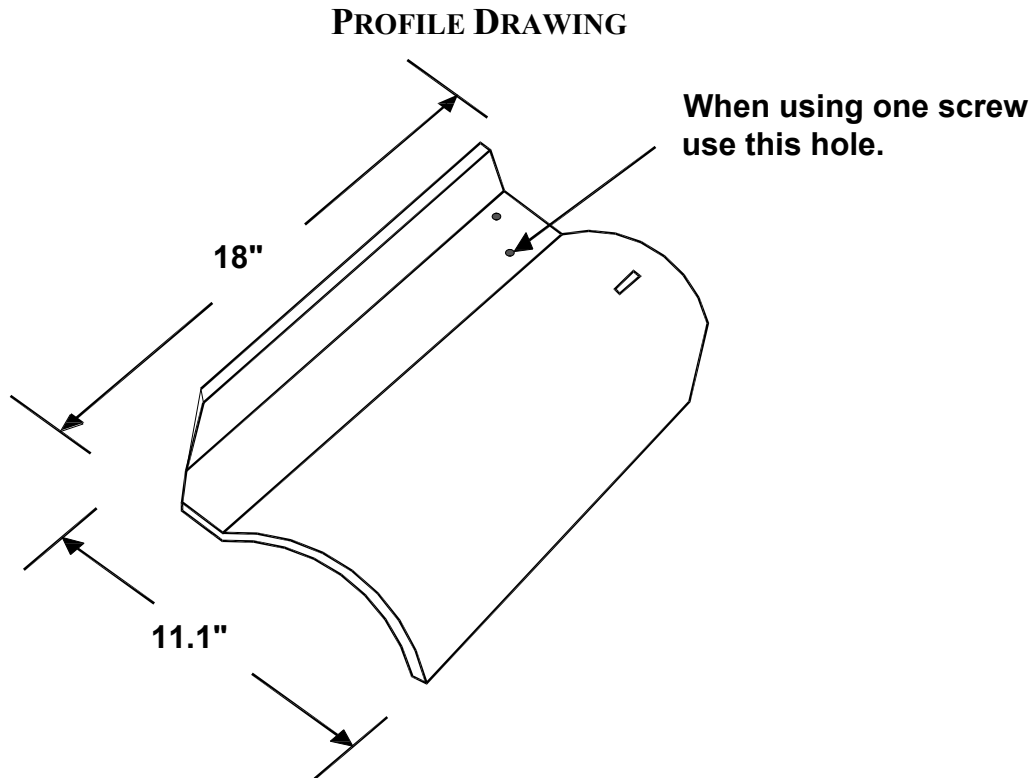

"SANTAFÉ S" CLAY ROOF TILE

END OF THIS ACCEPTANCE

