



MIAMI-DADE COUNTY, FLORIDA  
 PRODUCT CONTROL SECTION  
 11805 SW 26 Street, Room 208  
 Miami, Florida 33175-2474  
 T (786) 315-2590 F (786) 315-2599  
[www.miamidade.gov/economy](http://www.miamidade.gov/economy)

**DEPARTMENT OF REGULATORY AND ECONOMIC RESOURCES (RER)  
 BOARD AND CODE ADMINISTRATION DIVISION  
 NOTICE OF ACCEPTANCE (NOA)**

**Custom Window Systems, Inc.  
 1900 SW 44<sup>th</sup> Avenue  
 Ocala, FL 34474**

**SCOPE:**

This NOA is being issued under the applicable rules and regulations governing the use of construction materials. The documentation submitted has been reviewed and accepted by Miami-Dade County RER-Product Control Section to be used in Miami-Dade County and other areas where allowed by the Authority Having Jurisdiction (AHJ).

This NOA shall not be valid after the expiration date stated below. The Miami-Dade County Product Control Section (In Miami-Dade County) and/or the AHJ (in areas other than Miami-Dade County) reserve the right to have this product or material tested for quality assurance purposes. If this product or material fails to perform in the accepted manner, the manufacturer will incur the expense of such testing and the AHJ may immediately revoke, modify, or suspend the use of such product or material within their jurisdiction. RER reserves the right to revoke this acceptance, if it is determined by Miami-Dade County Product Control Section that this product or material fails to meet the requirements of the applicable building code.

This product is approved as described herein, and has been designed to comply with the Florida Building Code, including the High Velocity Hurricane Zone.

**DESCRIPTION: Series “CWS-380” Aluminum Sliding Glass Door (Standard Steel Reinforcement) - N.I.**

**APPROVAL DOCUMENT:** Drawing No. **CWS-1244**, titled “CWS 380 Non-Impact Aluminum Sliding Glass Door Standard Steel Reinforcement”, sheets 1 through 8 of 8, dated 11/17/23, with revision **A** dated 05/15/25, prepared by manufacturer, signed and sealed by Thomas J. Sotos, P.E., bearing the Miami-Dade County Product Control Revision stamp with the Notice of Acceptance number and expiration date by the Miami-Dade County Product Control Section.

**MISSILE IMPACT RATING: None.**

**LABELING:** Each unit shall bear a permanent label with the manufacturer's name or logo, Medley, FL and series and following statement: "Miami-Dade County Product Control Approved", unless otherwise noted herein.

**RENEWAL** of this NOA shall be considered after a renewal application has been filed and there has been no change in the applicable building code negatively affecting the performance of this product.

**TERMINATION** of this NOA will occur after the expiration date or if there has been a revision or change in the materials, use, and/ or manufacture of the product or process. Misuse of this NOA as an endorsement of any product, for sales, advertising or any other purposes shall automatically terminate this NOA. Failure to comply with any section of this NOA shall be cause for termination and removal of NOA.

**ADVERTISEMENT:** The NOA number preceded by the words Miami-Dade County, Florida, and followed by the expiration date may be displayed in advertising literature. If any portion of the NOA is displayed, then it shall be done in its entirety.

**INSPECTION:** A copy of this entire NOA shall be provided to the user by the manufacturer or its distributors and shall be available for inspection at the job site at the request of the Building Official.

This NOA **revises and supersedes NOA No. 23-0926.06** and consists of this page 1 and evidence pages E-1, E-2 and E-3, as well as approval document mentioned above.

The submitted documentation was reviewed by **Manuel Perez, P.E.**

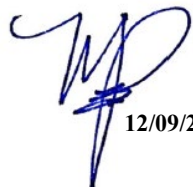

  
 12/09/25

**NOA No. 25-1201.05**  
**Expiration Date: August 26, 2028**  
**Approval Date: December 18, 2025**  
 Page 1

NOTICE OF ACCEPTANCE: EVIDENCE SUBMITTED

**1. EVIDENCE SUBMITTED UNDER PREVIOUS NOA's**

**A. DRAWINGS**

1. Manufacturer's die drawings and sections.  
*(Submitted under NOA's No. 99-0517.04 and 09-0706.06)*
2. Drawing No. **L9000-0902**, titled "SGD-9000 Aluminum Sliding Glass Door (N.I.) Standard Steel Reinforcement", sheets 1 thru 8 of 8, dated 08/04/09, with revision E dated 09/07/23, prepared by manufacturer, signed and sealed by Thomas J. Sotos, P.E.  
*(Submitted under NOA No. 23-0926.06)*

**B. TESTS**

1. Test reports on: 1) Uniform Static Air Pressure Test, Loading per FBC TAS 202-94 along with marked-up drawings and installation diagram of a series 9000 aluminum sliding glass door, prepared by QAI Laboratories, Test Reports No. **QAI-13822**, dated 09/12/23 and **QAI-13850**, dated 08/07/23, signed and sealed by Idalmis Ortega, P.E.  
*(Submitted under NOA No. 23-0926.06)*
2. Test reports on: 1) Uniform Static Air Pressure Test, Loading per FBC TAS 202-94 along with marked-up drawings and installation diagram of an aluminum sliding glass door, prepared by Hurricane Engineering & Testing, Inc., Test Reports No. **HETI-09-2534**, dated 05/05/09 and **HETI-09-2511**, dated 05/21/09, both signed and sealed by Candido F. Font, P.E.  
*(Submitted under NOA No. 09-0706.07)*
3. Test reports on: 1) Uniform Static Air Pressure Test, Loading per FBC TAS 202-94  
2) Large Missile Impact Test per FBC, TAS 201-94  
3) Cyclic Wind Pressure Loading per FBC, TAS 203-94  
4) Forced Entry Test, Type "C" sliding door, Grade 10, per FBC 2411.3.2.1, TAS 202-94 and per ASTM F 842-04  
along with marked-up drawings and installation diagram of an aluminum sliding glass door, prepared by Fenestration Testing Laboratory, Inc., Test Reports No. **FTL-2019**, **FTL-2021**, **FTL-2023**, **FTL-2024**, **FTL-2025**, **FTL-2026**, **FTL-2028**, **FTL-2029** and **FTL-2030**, dated 01/04/99, all signed and sealed by Gilbert Diamond, P.E.  
*(Submitted under NOA No. 99-0517.04)*

**C. CALCULATIONS**

1. Anchor verification calculations and structural analysis, complying with FBC, dated 04/28/15, prepared by manufacturer, signed and sealed by Thomas J. Sotos, P.E.  
*(Submitted under NOA No. 14-0908.04)*
2. Glazing complies with **ASTM E 1300-04/09**.

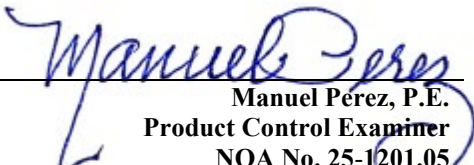
  
Manuel Pérez, P.E.  
Product Control Examiner  
NOA No. 25-1201.05  
Expiration Date: August 26, 2028  
Approval Date: December 18, 2025

Custom Window Systems, Inc.

NOTICE OF ACCEPTANCE: EVIDENCE SUBMITTED

**1. EVIDENCE SUBMITTED UNDER PREVIOUS NOA's (CONTINUED)**

**D. QUALITY ASSURANCE**

1. Miami-Dade Department of Regulatory and Economic Resources (RER)

**E. MATERIAL CERTIFICATIONS**

1. Technical data sheet of flexible vinyl compound FPVC 7267-75 (White) & FPVC 7200-75 (Black), published by Team Plastics, Inc./ Bayshore Vinyl Compounds, Inc. a division of Mexichem SAB de CV, LLC, expiring on 07/08/24.

**F. STATEMENTS**

1. Statement letter of conformance, complying with **FBC 8<sup>th</sup> Edition (2023)** dated September 18, 2023, issued by manufacturer, signed and sealed by Thomas J. Sotos P.E. *(Submitted under NOA No. 23-0926.06)*
2. Statement letter of no financial interest dated September 18, 2023, issued by manufacturer, signed and sealed by Thomas J. Sotos, P.E. *(Submitted under NOA No. 23-0926.06)*
3. Statement letter from QAI testing lab for upcoming scheduled test for Lawson Industries, Inc., dated 07/01/22, signed by Ms. Lusinda Delgado. *(Submitted under NOA No. 22-0613.04)*
4. RER email test proposal dated 06/28/22. *(Submitted under NOA No. 22-0613.04)*
5. Laboratory compliance letter for Test Reports No. **HETI-09-2534** and **HETI-08-2176**, dated 05/05/09, issued by Hurricane Engineering & Testing, Inc., signed and sealed by Candido F. Font, P.E. *(Submitted under NOA No. 09-0706.06)*
6. Proposal No. **08-0591**, issued by Product Control, dated 07/15/08, signed by Renzo Narciso. *(Submitted under NOA No. 09-0706.06)*
7. Laboratory compliance letter for Test Reports No. **FTL-2019, FTL-2021, FTL-2023, FTL-2024, FTL-2025, FTL-2028, FTL-2029** and **FTL-2030**, dated 01/04/99, issued by Fenestration Testing Laboratory, Inc., all signed and sealed by Gilbert Diamond, P.E. *(Submitted under NOA No. 99-0517.04)*
8. Proposal issued by Product Control, dated 04/14/98, signed by Jaime D. Gascon, P.E. *(Submitted under NOA No. 99-0517.04)*

**G. OTHERS**

1. Notice of Acceptance No. **22-0613.04**, issued to Lawson Industries, Inc., for their Series "SGD-9000 Dry Glazed" 8'0" Aluminum Sliding Glass Door w/Reinforcement – N.I., approved on 07/14/22 and expiring on 08/26/23.

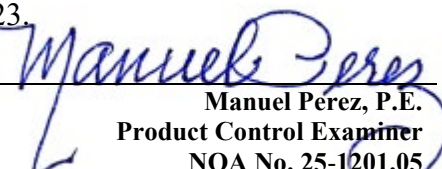
  
Manuel Perez, P.E.  
Product Control Examiner  
NOA No. 25-1201.05  
Expiration Date: August 26, 2028  
Approval Date: December 18, 2025

**Custom Window Systems, Inc.**

**NOTICE OF ACCEPTANCE: EVIDENCE SUBMITTED**

**2. NEW EVIDENCE SUBMITTED**

**A. DRAWINGS**

1. Drawing No. **CWS-1244**, titled “CWS 380 Non-Impact Aluminum Sliding Glass Door Standard Steel Reinforcement”, sheets 1 thru 8 of 8, dated 11/17/23, with revision **A** dated 05/15/25, prepared by manufacturer, signed and sealed by Thomas J. Sotos, P.E.

**B. TESTS**

1. None

**C. CALCULATIONS**

1. None

**D. QUALITY ASSURANCE**

1. Miami-Dade Department of Regulatory and Economic Resources (RER)

**E. MATERIAL CERTIFICATIONS**

1. None.

**F. STATEMENTS**

1. Statement letter of conformance, complying with **FBC 8<sup>th</sup> Edition (2023)**, dated November 20, 2025, issued by the manufacturer, signed and sealed by Thomas J. Sotos, P.E.
2. Statement letter of no financial interest, dated November 20, 2025, issued by the manufacturer, signed and sealed by Thomas J. Sotos, P.E.
3. Bill of Sales, Assignment and Assumption Agreement, dated November 28, 2023, signed by Mr. Harold Bailey, President, Lawson Industries, Inc. and Mr. Nicholas Cross, President, CWS-SF, LLC.
4. Letter from manufacturer, dated June 5, 2025, confirming that Custom Window Systems, Inc. is a wholly owned subsidiary of Pella Corporation, signed by Chantel Kramme, Secretary, Custom Window Systems, Inc.
5. Letter from owners of existing NOA No. **23-0926.06**, dated June 10, 2025, stating that they have sold all assets to the applicant, that they no longer manufacture the product and relinquish their rights to the current NOA, signed by Mr. Harold Bailey, President, Lawson Industries, Inc.

**G. OTHERS**

1. Notice of Acceptance No. **23-0926.06**, issued to Lawson Industries, Inc., for their Series “SGD-9000 Dry Glazed” 8’0” Aluminum Sliding Glass Door w/Standard Steel Reinforcement – N.I., approved on 10/19/23 and expiring on 08/26/28.

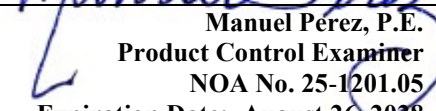
  
Manuel Pérez, P.E.  
Product Control Examiner  
NOA No. 25-1201.05  
Expiration Date: August 26, 2028  
Approval Date: December 18, 2025



1900 SW 44TH AVE.  
OCALA, FLORIDA 34474  
WWW.CWS.CC

**CWS 380 NON-IMPACT ALUMINUM  
SLIDING GLASS DOOR  
STANDARD STEEL  
REINFORCEMENT**

NO.	DESCRIPTION	BY	DATE
A	Revises NOA # 23-0926.06	N.E.	05/15/25

THOMAS J. SOTOS  
PROFESSIONAL ENGINEER  
FL LIC. # 55225

SEAL

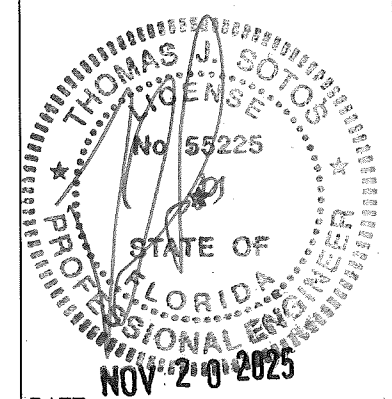

DATE: \_\_\_\_\_  
SHEET DESCRIPTION:  
GENERAL NOTES AND TEST  
DOOR CONFIGURATION

DRAWN BY: NELSON ERAZO DATE: 11/17/2023

REV. BY: N. E. DATE: 11/19/2025

DWG #: CWS-1244 REV #: A

SCALE: AS NOTED SHEET 1 OF 8

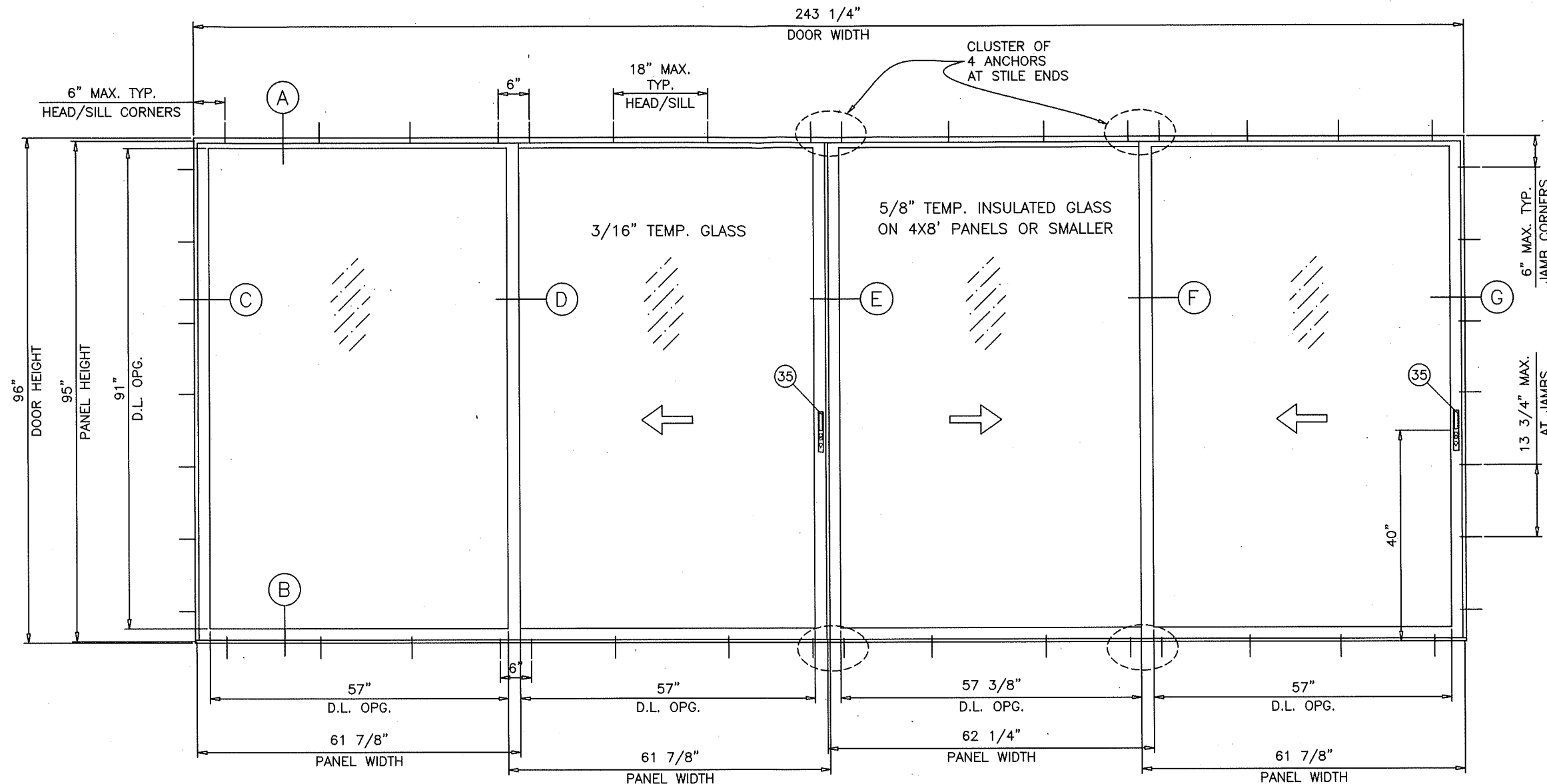

TYPICAL ELEVATION  
TESTED UNIT (OXXX)

**CWS 380 NON-IMPACT ALUMINUM SLIDING GLASS DOOR**

**NOTES:**

THIS PRODUCT HAS BEEN DESIGNED AND TESTED TO COMPLY WITH THE REQUIREMENTS OF THE FLORIDA BUILDING CODE (2023-8th EDITION).

SEE SHEET 2 FOR DESIGN LOAD CAPACITY OF DESIRED PANEL SIZE.

WOOD BUCKS BY OTHERS, MUST BE ANCHORED PROPERLY TO TRANSFER LOADS TO THE STRUCTURE.

ANCHORS SHALL BE AS LISTED, SPACED AS SHOWN ON DETAILS, ANCHORS EMBEDMENT TO BASE MATERIAL SHALL BE BEYOND WALL DRESSING OR STUCCO.

ANCHORING OR LOADING CONDITIONS NOT SHOWN IN THESE DETAILS ARE NOT PART OF THIS APPROVAL.

**NON-IMPACT  
STANDARD REINFORCING**

DOORS NOT RATED FOR IMPACT.  
INSTALLATION OF THIS PRODUCT REQUIRES THE USE OF APPROVED SHUTTERS OR EXTERNAL PROTECTION DEVICES COMPLYING WITH HVHZ REQUIREMENTS.

**PRODUCT REVISED**  
As complying with the Florida Building Code  
NOA-No. **25-1201.05**  
Expiration Date: **08/26/2028**  
By: *Manuel Perez*  
Miami-Dade Product Control

ITEM #	PART #	QUANTITY	DESCRIPTION	MATERIAL	MANUF./SUPPLIER/REMARKS
1	L-9001	1	FRAME HEAD (2 TRACK)	6063-T6 ALUM.	PROFILE
2	L-9002	1	FRAME SILL (2 TRACK)	6063-T6 ALUM.	PROFILE
3	L-9003	2	FRAME JAMB (2 TRACK)	6063-T5 ALUM.	PROFILE
4	L-9004	1/ PANEL	PANEL TOP RAIL	6063-T5 ALUM.	PROFILE
5	L-9005	1/ PANEL	PANEL BOTTOM RAIL	6063-T5 ALUM.	PROFILE
6	L-9006	AS REQD.	LOCK STILE / FIXED STILE	6063-T5 ALUM.	PROFILE
7	L-9007	AS REQD.	SINGLE INTERLOCK STILE	6063-T5 ALUM.	PROFILE
8	L-9008	AS REQD.	ASTRAGAL STILE	6063-T6 ALUM.	PROFILE
9	L-9043	AS REQD.	3/16" GLAZING CHANNEL	TEAM PLASTICS Inc.	See Material Composition @ Sheet 8
10	FS-011	4/ PANEL	PANEL ASS'Y SCREW @ TOP RAIL		#10 x 5/8" P.H. - PHILLIPS
11	FS-034	2/ PANEL	PANEL ASS'Y SCREW @ BOTTOM RAIL	-	#10-24 X 1" P.H.-PHIL./ "T"
12	FS-028	8	FRAME ASSEMBLY SCREW	-	#8 X 7/16" P.H.-PHIL. / SMS
13	7519-6001-7	AS REQD.	PILE WTS'P. @ JAMB/ASTRAGAL	-	(0.187"w. x 0.200"h.)-Schlegel
14	7524-6001-6	AS REQD.	PILE WTS'P. @ TOP RAILS	-	(0.187"w. x 0.250"h.)-Schlegel
15	7529-6001-7	AS REQD.	PILE WTS'P. @ BOTTOM RAILS	-	(0.187"w. x 0.300"h.)-Schlegel
16	7520-5001-7	AS REQD.	PILE WTS'P. @ INTERLOCKS	-	(0.187"w. x 0.210"h.)-Schlegel
17		AS REQD.	SILL RISER	6063-T5 ALUM.	SILICONED IN PLACE
18	L-9018	3 OR 4 *	FIXED PANEL JAMB CLIP	6063-T5 ALUM.	GW-27153
19	FS-029	1/ CLIP	FIXED PANEL CLIP SCREW	-	#8 X 5/8" PH.-PHI / SDS
20	AR-001	1	FIXED INTERLOCK ANGLE	6063-T5 ALUM.	3"x 1 1/2"x 1 9/16"x 1/8"
21	AR-002	1	MOVING INTERLOCK ANGLE/CLIP	6063-T5 ALUM.	1 1/2" X 3/4" X 2" X 1/8"
22	L-9022	1	ASTRAGAL RETAINER CLIP	6063-T6 ALUM.	AF-10798
23	AR-020	AS REQD.	REINF. @ SINGLE INTERLOCK	A36 C.R. STEEL	1/2" X 1 1/4" BAR (36 KSI)
24	AR-021	AS REQD.	REINF. @ DOUBLE INTERLOCK\ASTRAGAL	A36 C.R. STEEL	1/2" X 1 1/2" BAR (36 KSI)
27	*	OPTIONAL	SCREEN JAMB ADAPTER	6063-T6 ALUM.	-
28	L-9028	1	FRAME HEAD (3 TRACK)	6063-T6 ALUM.	-
29	L-9029	1	FRAME SILL (3 TRACK)	6063-T6 ALUM.	-
30	L-9030	2	FRAME JAMB (3 TRACK)	6063-T5 ALUM.	-
31	L-9031	AS REQD.	DOUBLE INTERLOCK STILE	6063-T6 ALUM.	OPTIONAL
32	1071a	2/ PANEL	PANEL TOP GUIDE	ST801 Nylon 6-6	Molded Nylon- Rockwell M scale: 79
33	1072a	2/ PANEL	PANEL BOTTOM GUIDE	ST801 Nylon 6-6	Molded Nylon- Rockwell M scale: 79
34	HW4-WHL	2/ PANEL	PANEL SINGLE ROLLER		6 COMPONENT - ASS'Y 150
35	HC-038	AS REQ'D.	DOOR LOCK ASSEMBLY	-	INT. & EXT. PULLS, CAM, KEEPER
36	LII-109A	1/ PANEL	5/8" INSULATED PANEL TOP RAIL	6063-T6 ALUM.	PROFILE
37	LII-110A	1/ PANEL	5/8" INSULATED PANEL BOTTOM RAIL	6063-T5 ALUM.	PROFILE
38	LII-108	1/ PANEL	5/8" INSULATED PANEL LOCK STILE	6063-T6 ALUM.	PROFILE
39	LII-082	1/ PANEL	5/8" INSULATED PANEL INTERLOCK	6063-T6 ALUM.	PROFILE
40	LII-163	1/ PANEL	5/8" INSULATED PANEL ASTRAGAL	6063-T6 ALUM.	PROFILE
41	AF-10403	AS REQ'D.	POCKET DOOR JAMB HOOK	6063-T6 ALUM.	PROFILE
42	L-9045	AS REQ'D.	5/8" INSULATED GLAZING CHANNEL	TEAM PLASTICS Inc.	See Material Composition. @ Sheet 8
43 a	812-25H-357	AS REQ'D.	"TruSeal" Dura Seal Swiggle Spacer	*	Black - 1/4" Air Space
43 b	Quanex	AS REQ'D.	"Quanex" Super Spacer w/ Isomelt M	*	Black - 1/4" Air Space

\* 4 ON 9/0 HIGH DOORS ONLY

		DESIGN LOAD CAPACITY - PSF							
		3/16" TEMP. GLASS							
PANEL WIDTH NOMINAL FT./IN.	DOOR HEIGHT FT./IN.	1-3/4" SILL		2-1/4" SILL		2-1/2" SILL		3" SILL	
		EXT. (+)	INT. (-)	EXT. (+)	INT. (-)	EXT. (+)	INT. (-)	EXT. (+)	INT. (-)
2/6	6/8	40.7	99.0	56.7	99.0	63.3	99.0	77.8	99.0
3/0		40.7	87.2	56.7	87.2	63.3	87.2	77.8	87.2
4/0		40.7	73.1	56.7	73.1	63.3	73.1	73.1	73.1
5/0		40.7	65.9	56.7	65.9	63.3	65.9	65.9	65.9
2/6	8/0	40.7	79.3	56.7	79.3	63.3	79.3	77.8	79.3
3/0		40.7	69.1	56.7	69.1	63.3	69.1	69.1	69.1
4/0		40.7	56.7	56.7	56.7	56.7	56.7	56.7	56.7
5/0		40.7	49.7	49.7	49.7	49.7	49.7	49.7	49.7
2/6	9/0	40.7	59.6	56.7	59.6	59.6	59.6	59.6	59.6
3/0		40.7	50.7	50.7	50.7	50.7	50.7	50.7	50.7
4/0		39.8	39.8	39.8	39.8	39.8	39.8	39.8	39.8

5/8" TEMP. INSULATED GLASS MAY BE USED IN 4X8' PANELS OR SMALLER.

GLASS CAPACITIES ON THIS CHART ARE BASED ON  
ASTM E1300-16 (60 SEC. WIND)

Tempered Glass marked and in compliance  
with Section 2406 Safety Glazing: CPSC 16  
CFR Part 1201" or "ANSI Z97.1-2015.

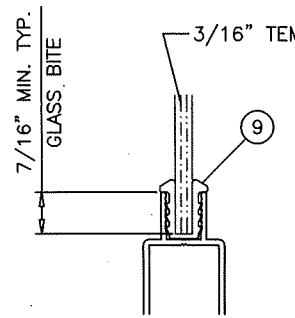

3/16 TEMP. GLAZING DETAIL

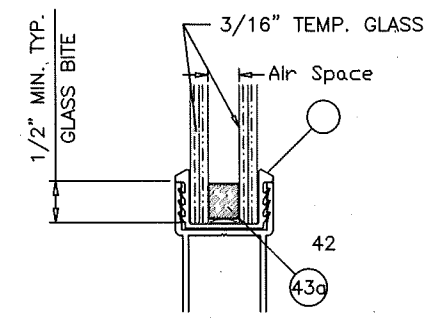

5/8 TEMP. INSULATED GLAZING DETAIL

- (43) Insulated Spacer Types & Options  
 43 a) "TrueSeal" Swiggle Seal  
 43 b) "Quanex" SuperSpacer w/ Isomelt M

THIS APPROVES DOORS USING TWO (2) OR THREE (3) TRACK FRAMES  
WITH ANY NUMBER OF PANELS THAT CONTAIN THE STILE CONFIGURATIONS  
SHOWN ON SHEETS 4 AND 6, I.E. XX, OX, XO, XXX, OXO, OXXO,  
AND THE FOLLOWING POCKET DOOR CONFIGURATIONS:  
XXp, pXX, XXXp, pXXX, XXXXp, pXXXX, pXXXXp  
OXXXp, pXXXO

**PRODUCT REVISED**  
 As complying with the Florida  
 Building Code  
 NOA-No. **25-1201.05**  
 Expiration Date: **08/26/2028**  
 By: *Manuel Perez*  
 Miami-Dade Product Control

1900 SW 44TH AVE.  
OCALA, FLORIDA 34474  
WWW.CWS.CC

**CWS 380 NON-IMPACT ALUMINUM  
SLIDING GLASS DOOR  
STANDARD STEEL  
REINFORCEMENT**

NO.	DESCRIPTION:	REVISIONS
A	Revises NDA # 23-0926.06	05/15/25 DATE: BY:

THOMAS J. SOTOS  
PROFESSIONAL ENGINEER  
FL LIC. # 55225

DATE: NOV 20 2025  
 SHEET DESCRIPTION:  
 BILL OF MATERIALS,  
 GLAZING DETAILS & DP  
 LOAD CHARTS

DRAWN BY: NELSON ERAZO	DATE: 11/17/2023
REV. BY: N. E.	DATE: 11/19/2025
DWG #: CWS-1244	REV #: A
SCALE: AS NOTED	SHEET 2 OF 8



1900 SW 44TH AVE.  
OCALA, FLORIDA 34474  
WWW.CWS.CC

**CWS 380 NON-IMPACT ALUMINUM  
SLIDING GLASS DOOR  
STANDARD STEEL  
REINFORCEMENT**

NO.	DESCRIPTION	BY	DATE
A	Revises NOA # 23-0926.06	N.E.	05/15/25

**THOMAS J. SOTOS**  
PROFESSIONAL ENGINEER  
FL LIC. # 55225

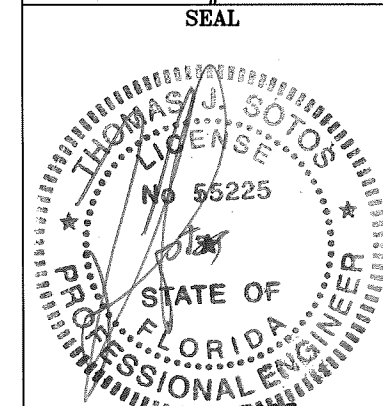

DATE **NOV 20 2025**

SHEET DESCRIPTION:  
2 TRACK VERTICAL  
SECTIONS, ANCHOR  
DETAILS & NOTES

DRAWN BY: NELSON ERAZO DATE: 11/17/2023

REV. BY: N. E. DATE: 11/19/2025

DWG #: CWS-1244 REV #: A

SCALE: AS NOTED SHEET 3 OF 8

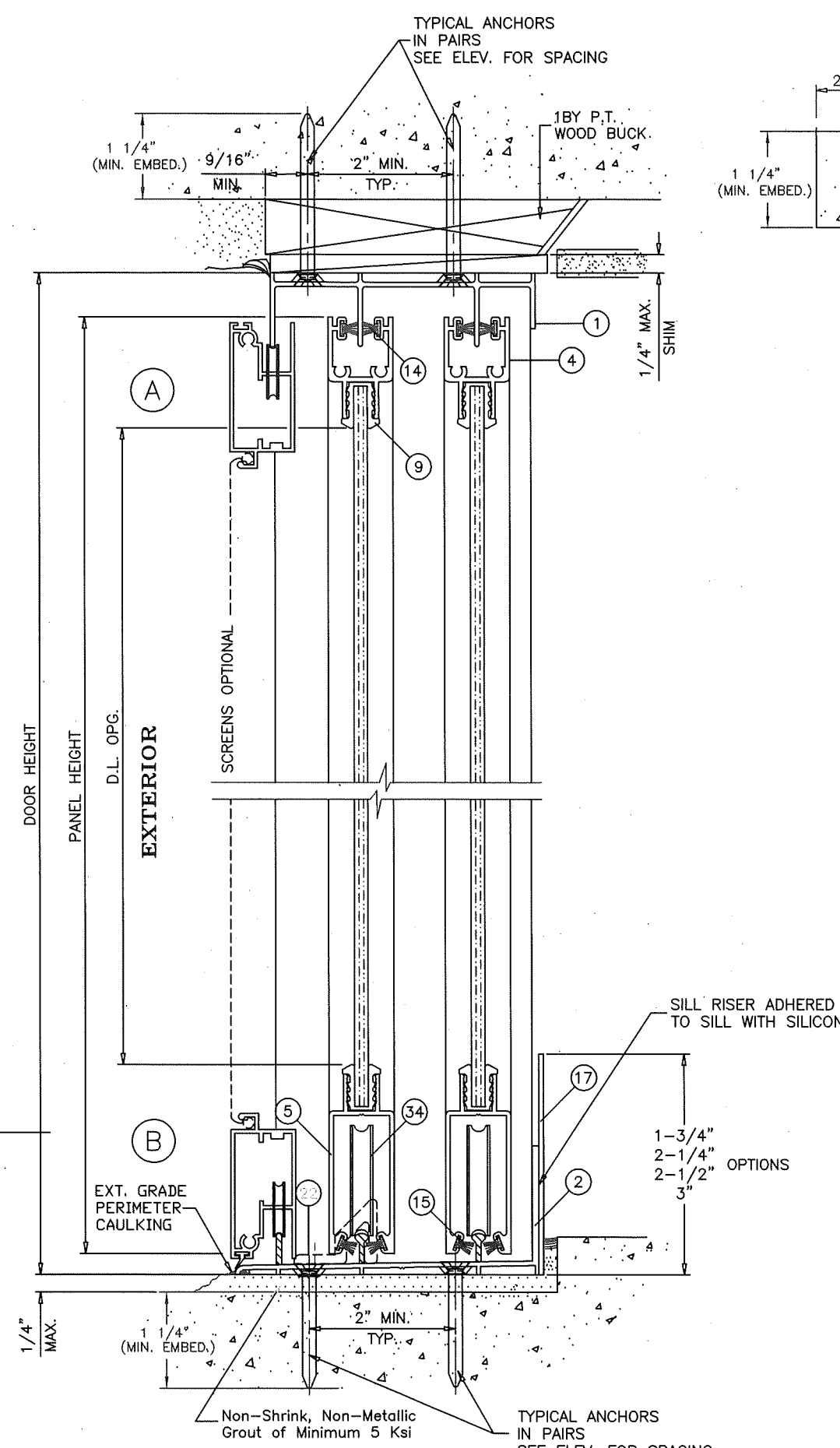

**TWO (2) TRACK SECTION**

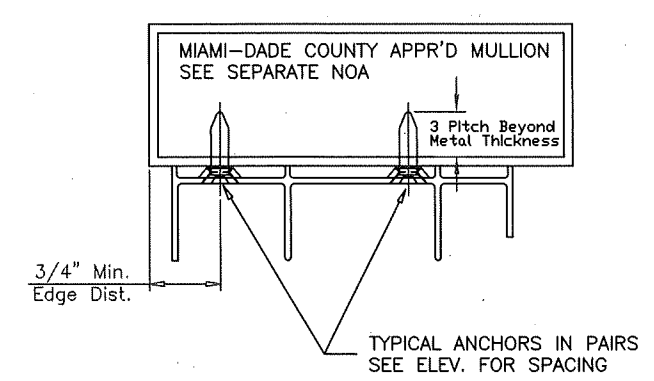
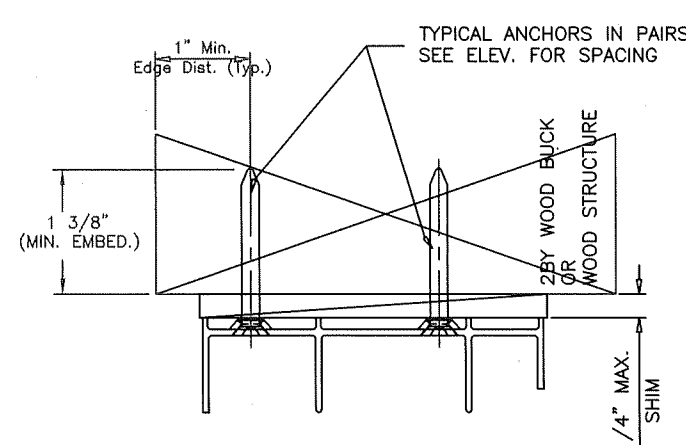
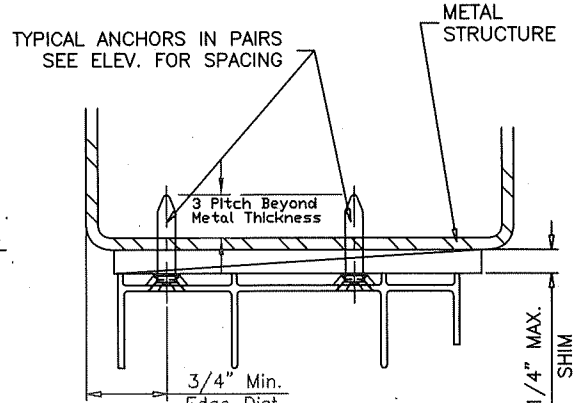
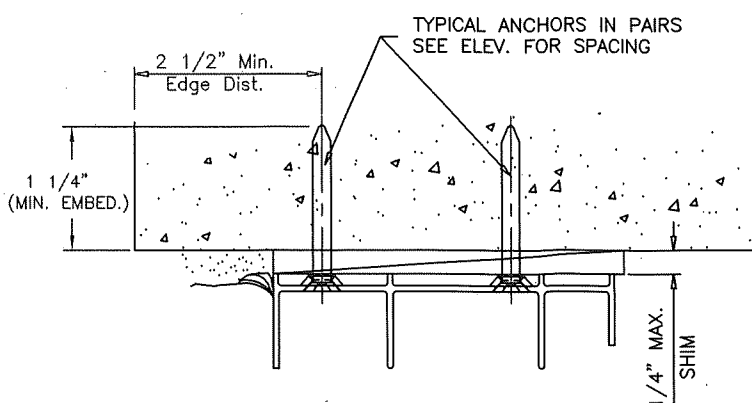

WOOD BUCKS AND METAL STRUCTURES NOT BY CWS MUST SUPPORT LOADS IMPOSED BY GLAZING SYSTEM AND TRANSFER THEM TO THE BUILDING STRUCTURE.

**TYPICAL ANCHORS:** ( SEE ELEV. FOR SPACING )  
 1/4" DIA TAPCONS by ITW BUILDEX (Fy= 100 Ksi, Fu= 125Ksi)  
 INTO 2BY WOOD BUCKS OR WOOD STRUCTURE.  
 1-3/8" MIN. PENETRATION INTO WOOD  
 THRU 1BY WOOD BUCKS INTO MASONRY OR CONC.  
 1-1/4" MIN. EMBED INTO MASONRY OR CONC.  
 DIRECTLY INTO CONCRETE OR MASONRY  
 1-1/4" MIN. EMBED INTO CONCRETE OR MASONRY

**#14 SMS OR SELF DRILLING SCREWS - GRADE 5**  
 INTO METAL STRUCTURES  
 STEEL : 12 GA. MIN. THICK - 0.105" (Fy = 36 KSI MIN.)  
 ALUMINUM : 1/8" THK. MIN. (6063-T5 MIN.)

**#10 SMS - GRADE 2**  
 INTO MIAMI-DADE COUNTY APPROVED MULLIONS (MIN. THK. = 1/8")  
 (NO SHIM SPACE)

**TYPICAL EDGE DISTANCES**  
 INTO CONCRETE AND MASONRY = 2-1/2" MIN.  
 INTO WOOD STRUCTURE = 1" MIN. (OR AS SHOWN)  
 INTO METAL STRUCTURE = 3/4" MIN.

**SUBSTRATES:**  
 WOOD BUCK (P.T.) AT HEAD OR JAMBS SG = 0.55 MIN.  
 CONCRETE AT HEAD, SILL OR JAMBS F'c = 3000 PSI MIN.  
 C-90 GROUT / FILLED BLOCK AT JAMBS F'm = 2000 PSI MIN.

**SEALANTS:**  
 ALL FRAME AND PANEL JOINT, INSTALLATION SCREWS AND HEADS OF ANCHOR SCREWS AT SILL TO BE SEALED WITH SEALANT.

**PRODUCT REVISED**  
 As complying with the Florida Building Code  
 NOA-No. **25-1201.05**  
 Expiration Date: **08/26/2028**  
 By: *Manuel Perez*  
 Miami-Dade Product Control

NOTE: LENGTH OF STEEL REINFORCING TO BE DOOR HEIGHT - 7"  
FOR 6/8 DOORS = 73"  
FOR 8/0 DOORS = 89"  
FOR 9/0 DOORS = 101"

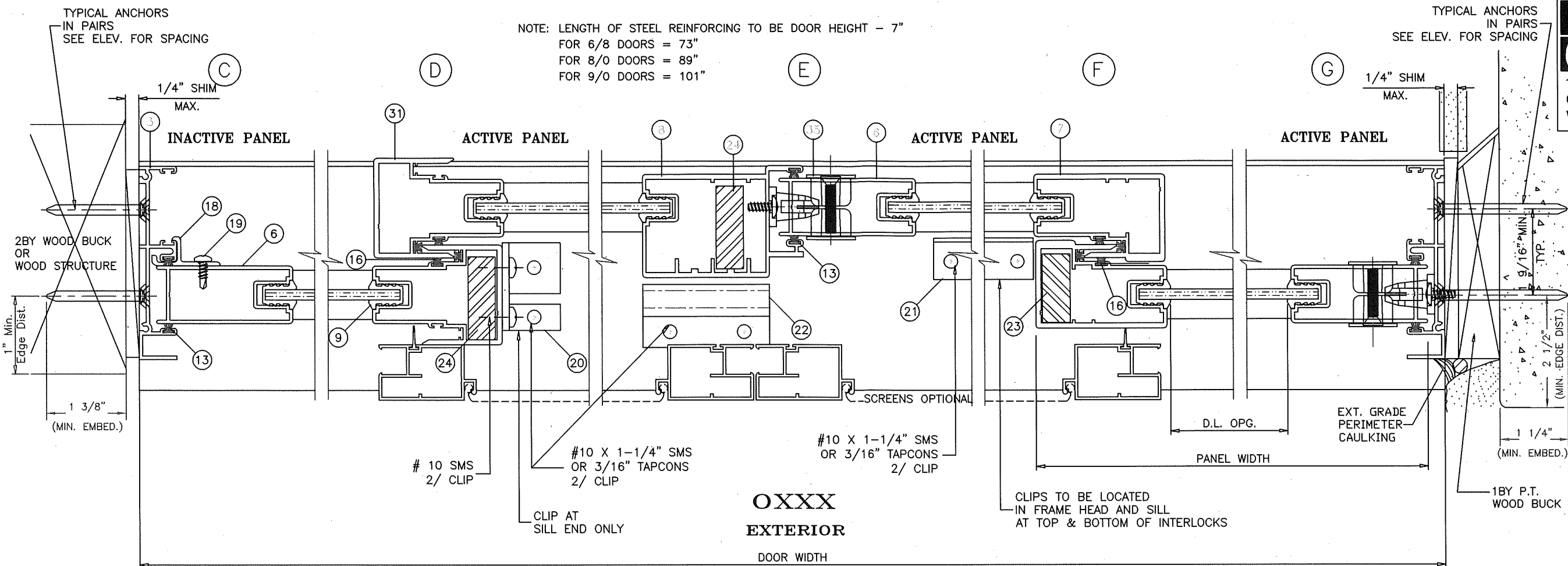

**CWS 380 NON-IMPACT ALUM SLIDING GLASS DOOR STANDARD STEEL REINFORCEMENT**

NO.	DESCRIPTION	BY	DATE
A	Revises NDA # 23-0926.06	N.E.	05/15/25

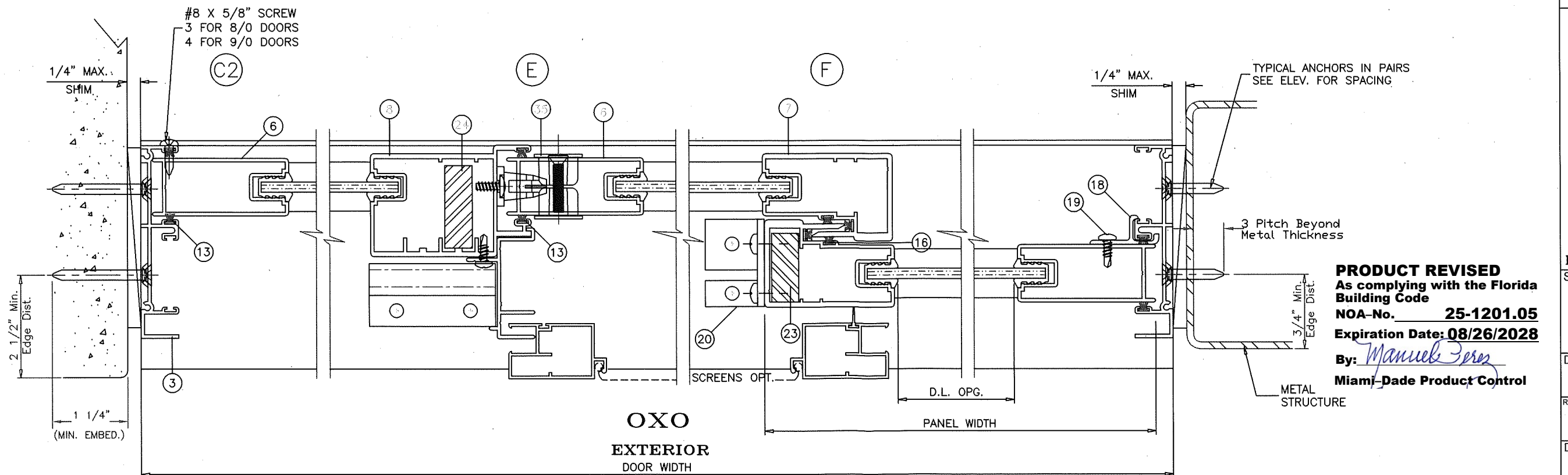

**PRODUCT REVISED**  
As complying with the Florida Building Code  
NOA-No. **25-1201.05**  
Expiration Date: **08/26/2028**  
By: *Manuel Perez*  
Miami-Dade Product Control

THOMAS J. SOTOS  
PROFESSIONAL ENGINEER  
FL LIC. # 55225  
SEAL

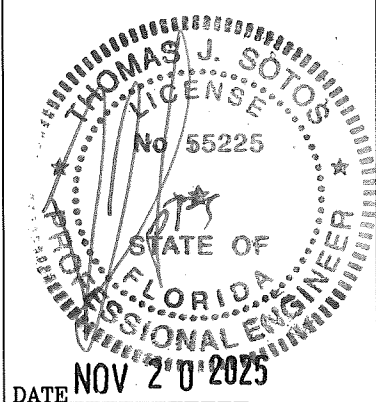

DATE: **NOV 20 2025**

SHEET DESCRIPTION:  
2 TRACK HORIZONTAL CROSS SECTIONS

DRAWN BY: NELSON ERAZO	DATE: 11/17/2023
REV. BY: N. E.	DATE: 11/19/2025
DWG #: CWS-1244	REV #: A
SCALE: AS NOTED	SHEET 4 OF 8

**TWO (2) TRACK SECTION**

**CWS 380 NON-IMPACT ALUMINUM  
 SLIDING GLASS DOOR  
 STANDARD STEEL  
 REINFORCEMENT**

NO.	DESCRIPTION	BY	DATE
A	Revises NDA # 23-0926.06	N.E.	05/15/25

**THOMAS J. SOTOS**  
 PROFESSIONAL ENGINEER  
 FL LIC. # 55225

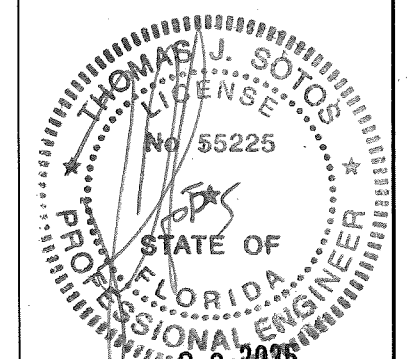

DATE: **NOV 20 2025**  
 SHEET DESCRIPTION:  
 3 TRACK VERTICAL CROSS  
 SECTIONS, ANCHOR  
 DETAILS & NOTES

DRAWN BY: NELSON ERAZO	DATE: 11/17/2023
REV. BY: N. E.	DATE: 11/19/2025
DWG #: CWS-1244	REV #: A
SCALE: AS NOTED	SHEET 5 OF 8

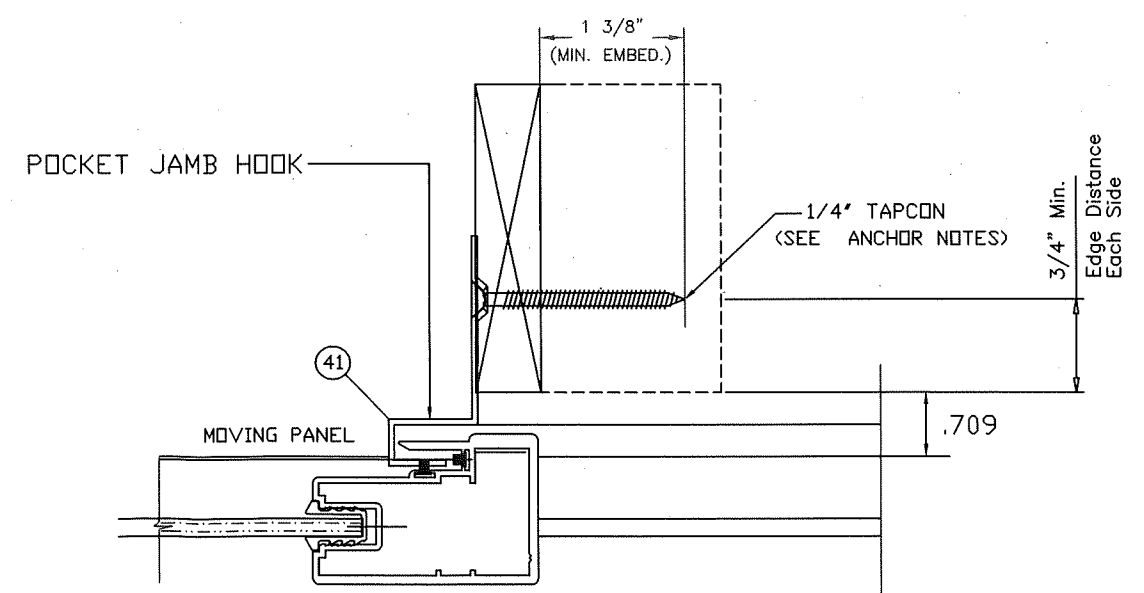
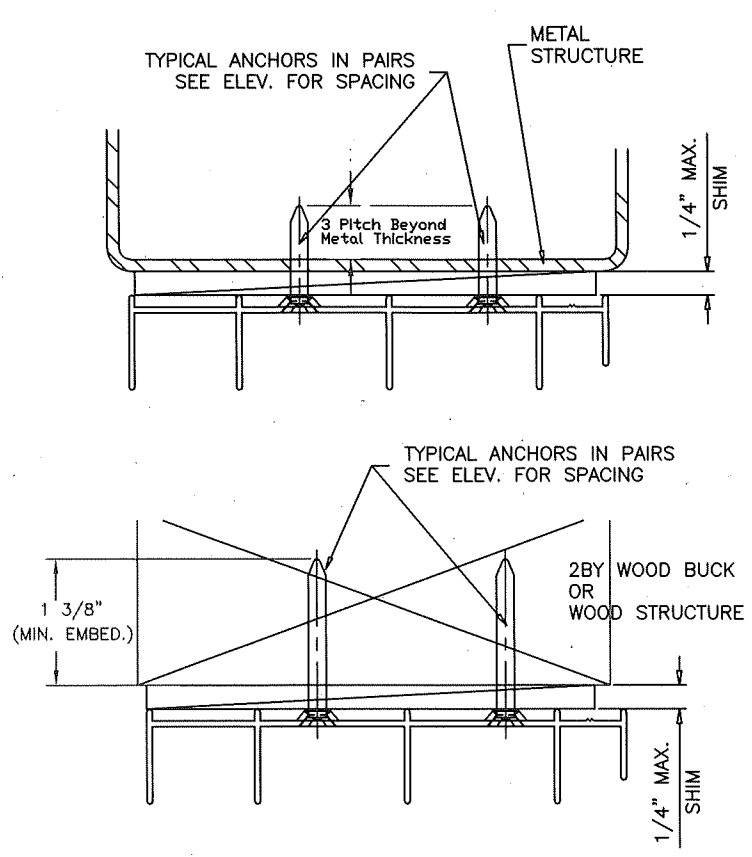
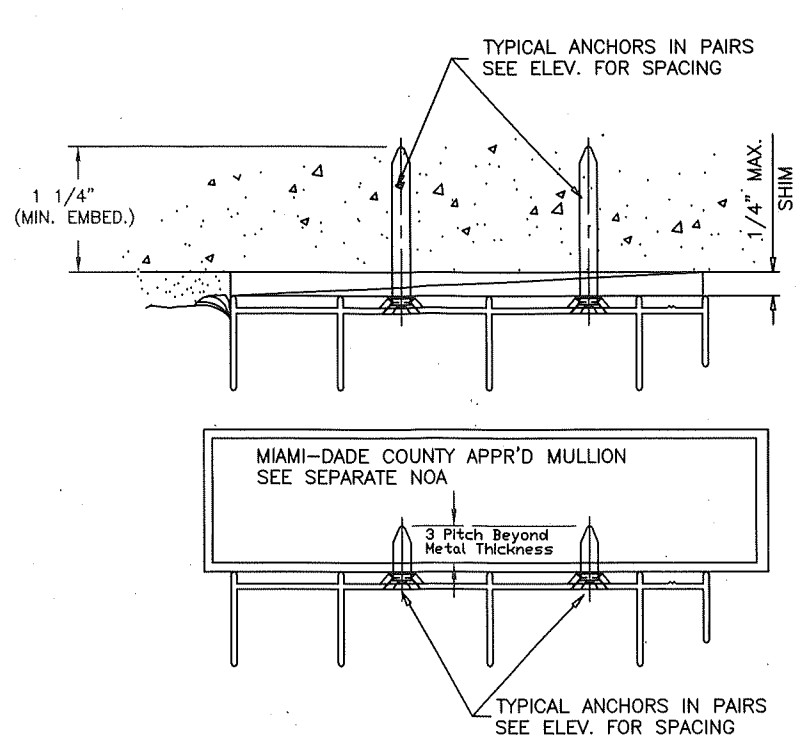
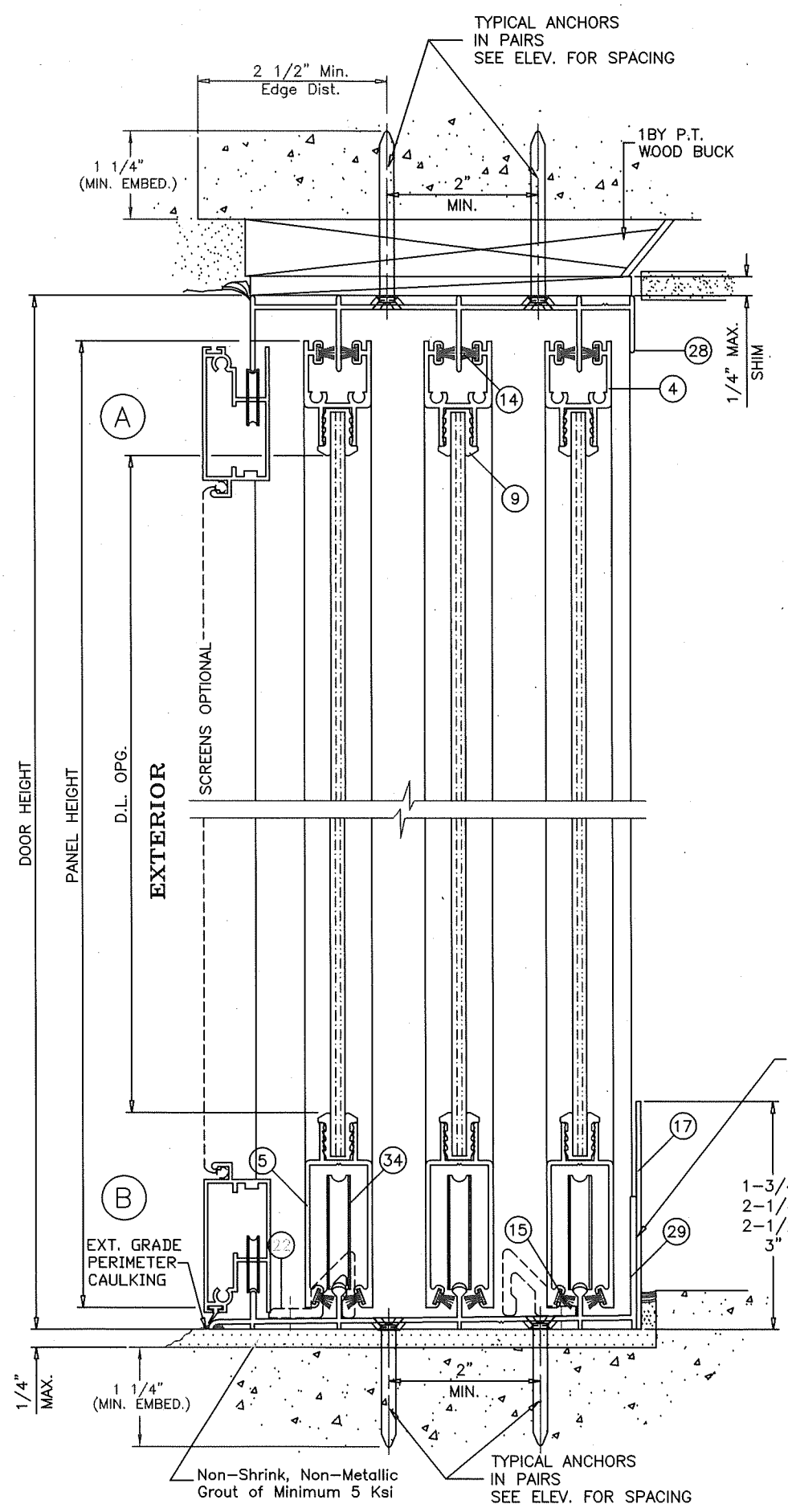

**POCKET DOOR JAMB ANCHOR DETAIL**

**PRODUCT REVISED**  
 As complying with the Florida Building Code  
 NOA-No. **25-1201.05**  
 Expiration Date: **08/26/2028**  
 By: *Manuel Perez*  
 Miami-Dade Product Control

NOTE: LENGTH OF STEEL REINFORCING TO BE DOOR HEIGHT - 7"  
 FOR 6/8 DOORS = 73"  
 FOR 8/0 DOORS = 89"  
 FOR 9/0 DOORS = 101"

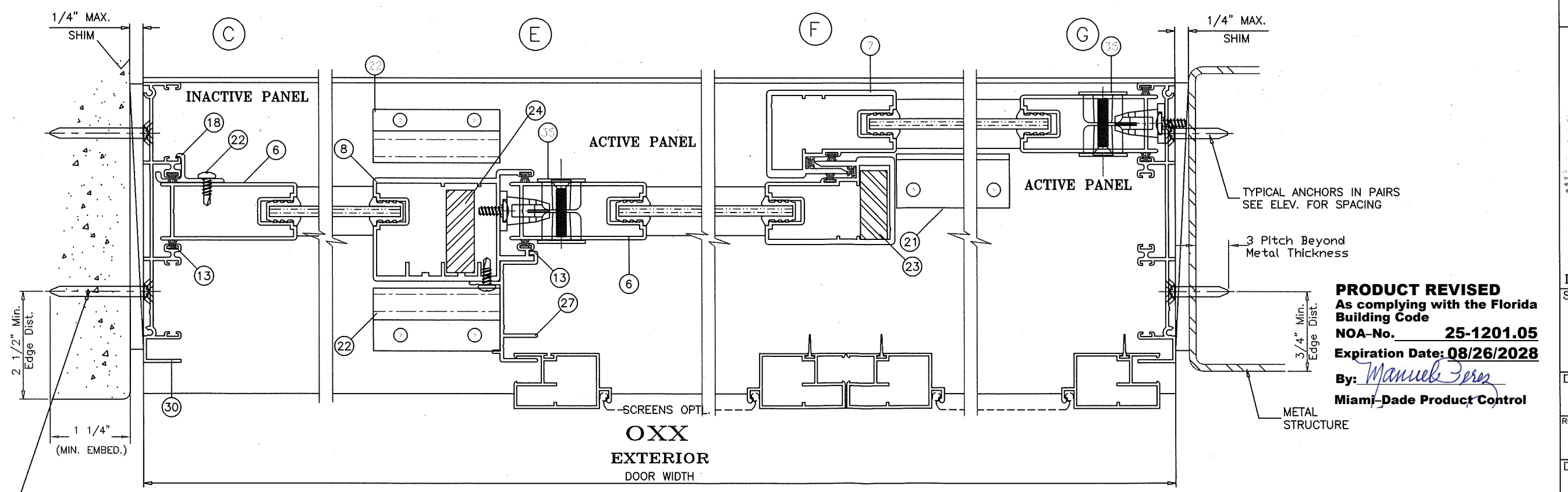
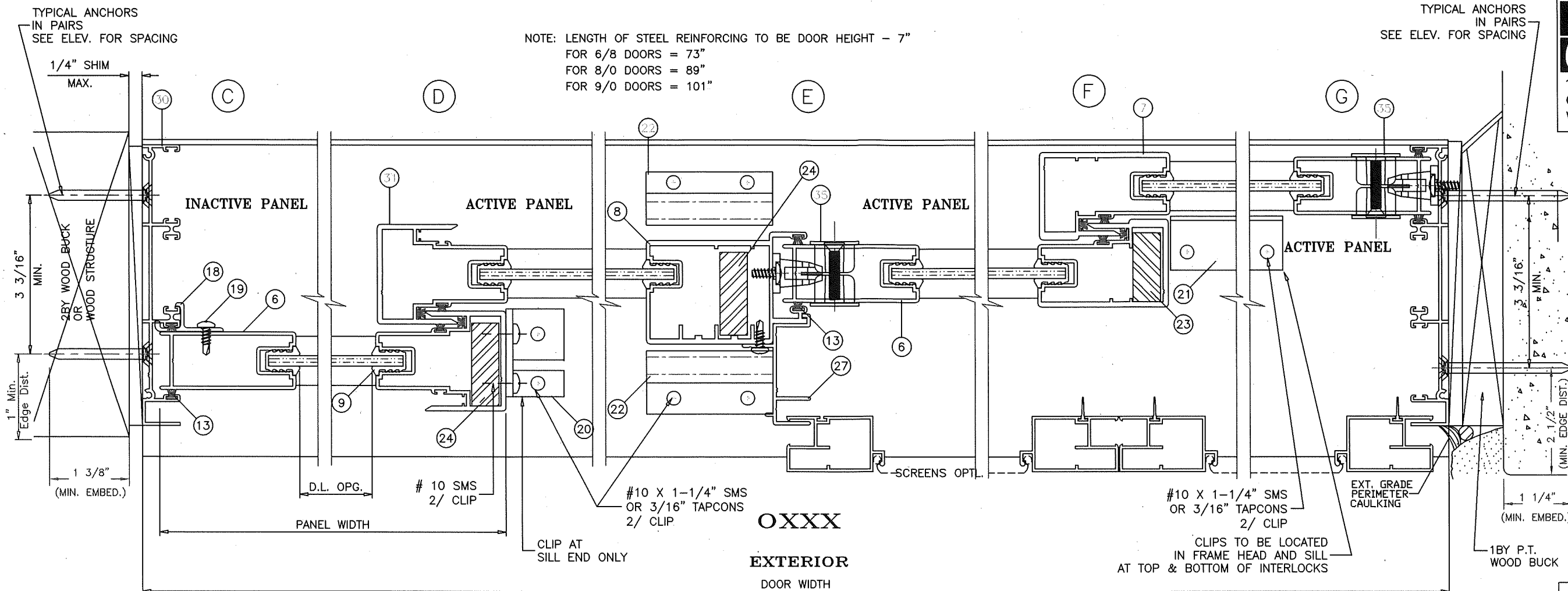

**CWS 380 NON-IMPACT ALUM SLIDING GLASS DOOR STANDARD STEEL REINFORCEMENT**

NO.	DESCRIPTION	BY	DATE
A	Revises NOA # 23-0926.06	N.E.	05/15/25

**THOMAS J. SOTOS**  
 PROFESSIONAL ENGINEER  
 FL LIC. # 55225

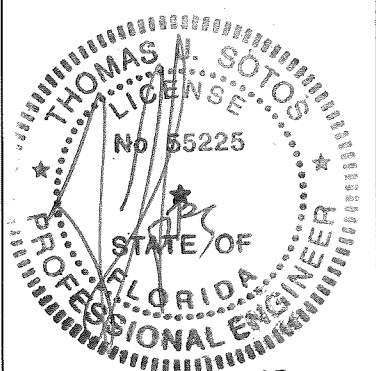

DATE **NOV 20 2025**

SHEET DESCRIPTION:  
 3 TRACK HORIZONTAL CROSS SECTIONS

**PRODUCT REVISED**  
 As complying with the Florida Building Code  
 NOA-No. **25-1201.05**  
 Expiration Date: **08/26/2028**  
 By: *Manuel Erazo*  
 Miami-Dade Product Control

DRAWN BY: NELSON ERAZO DATE: 11/17/2023

REV. BY: N. E. DATE: 11/19/2025

DWG #: CWS-1244 REV #: A

SCALE: AS NOTED SHEET 6 OF 8

**THREE (3) TRACK SECTION**

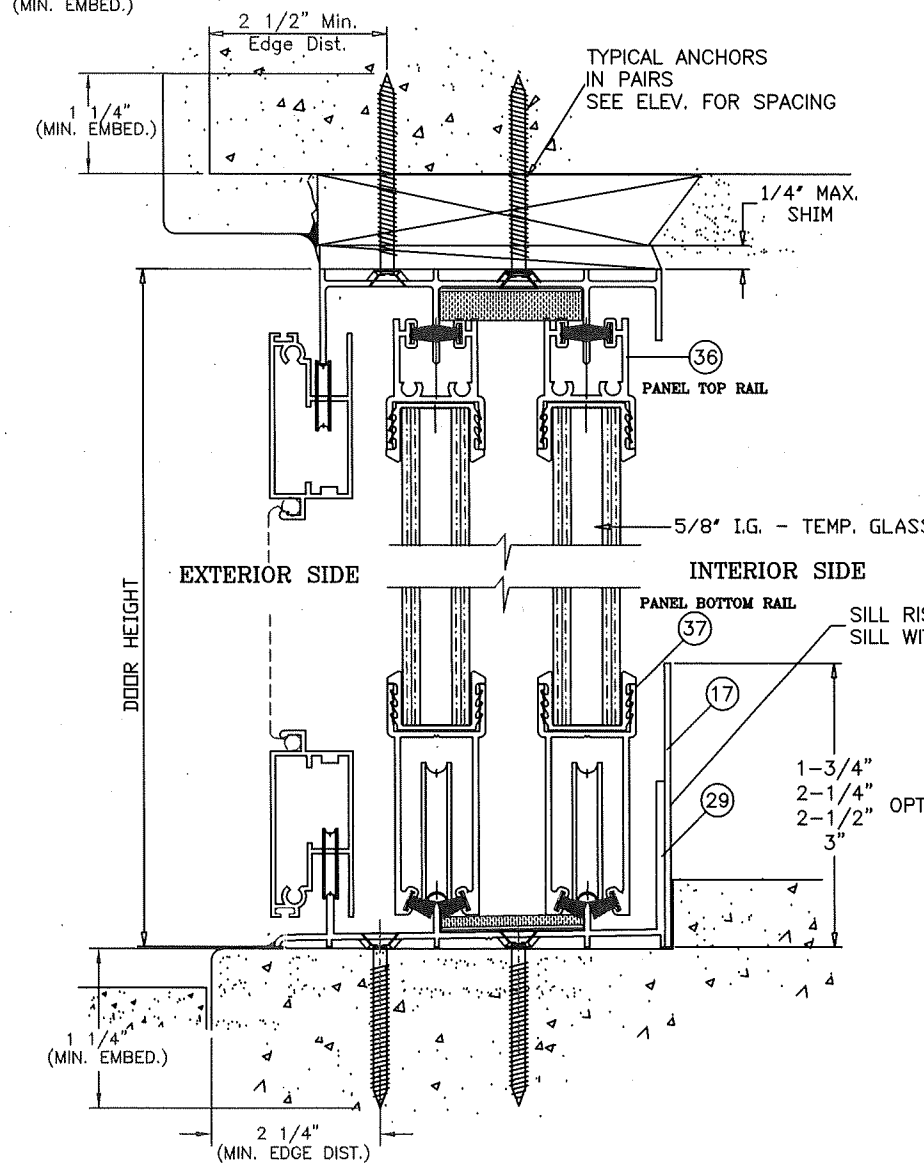
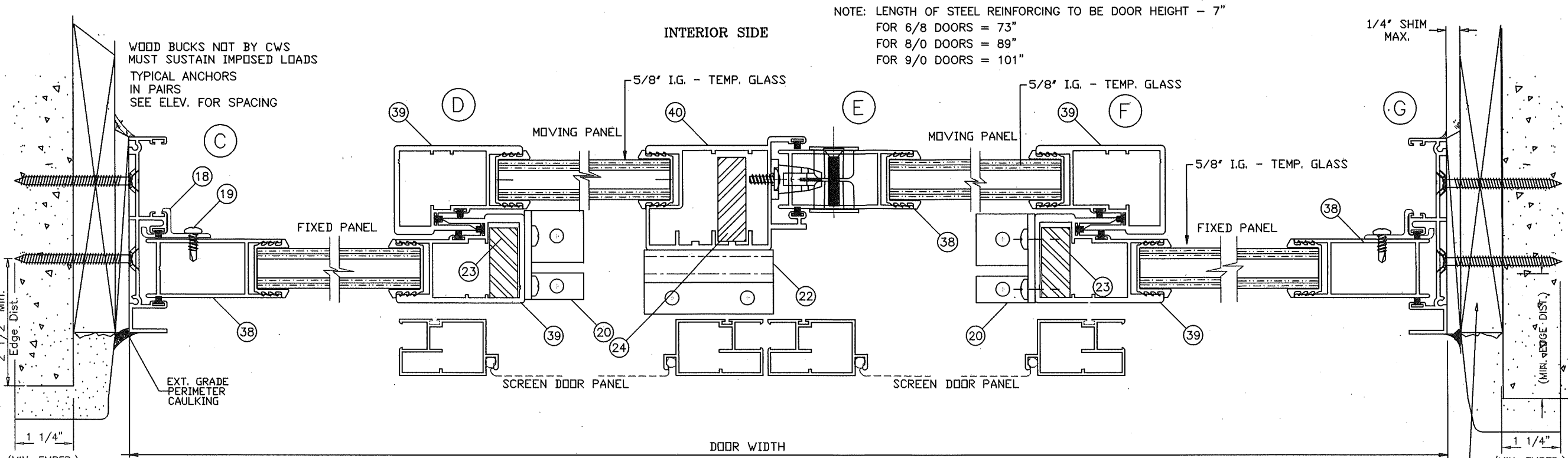

Note:  
INSULATED PANELS APPROVED TO BE USED IN ANY CONFIGURATION SIMILAR TO THOSE AS SHOWN ON SHEETS 4, 5, & 6.

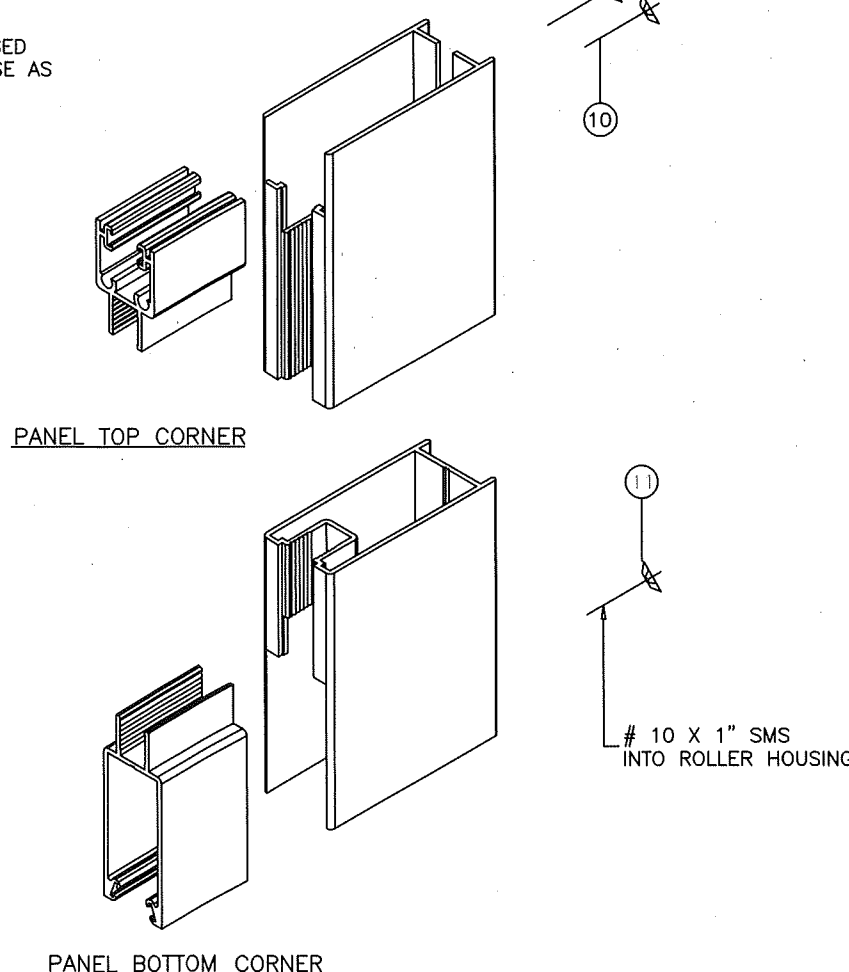

**CWS**  
1900 SW 44TH AVE.  
OCALA, FLORIDA 34474  
WWW.CWS.CC

**CWS 380 NON-IMPACT ALUMINUM SLIDING GLASS DOOR STANDARD STEEL REINFORCEMENT**

NO.	DESCRIPTION	BY	DATE
A	Revises NIA # 23-0926.06	N.E.	05/15/25

THOMAS J. SOTOS  
PROFESSIONAL ENGINEER  
FL LIC. # 55225  
SEAL

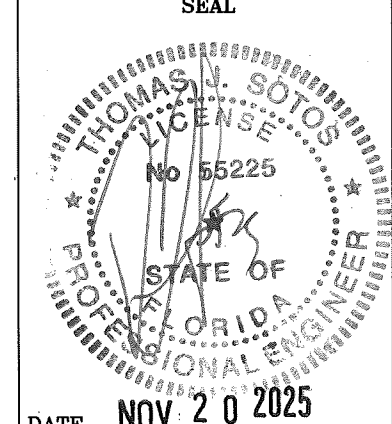

SHEET DESCRIPTION:  
INSULATED DOOR PANEL SECTIONS & PANEL TYPE DETAILS

DRAWN BY: NELSON ERAZO	DATE: 11/17/2023
REV. BY: N. E.	DATE: 11/19/2025
DWG #: CWS-1244	REV #: A
SCALE: AS NOTED	SHEET 7 OF 8

**PRODUCT REVISED**  
As complying with the Florida Building Code  
NOA-No. **25-1201.05**  
Expiration Date: **08/26/2028**  
By: *Manuel Perez*  
Miami-Dade Product Control



1900 SW 44TH AVE.  
OCALA, FLORIDA 34474  
WWW.CWS.CC

**CWS 380 NON-IMPACT ALUMINUM  
SLIDING GLASS DOOR  
STANDARD STEEL  
REINFORCEMENT**

NO.	DESCRIPTION	BY	DATE
A	Revises NOA # 23-0926.06	N.E.	05/15/25

THOMAS J. SOTOS  
PROFESSIONAL ENGINEER  
FL LIC. # 55225

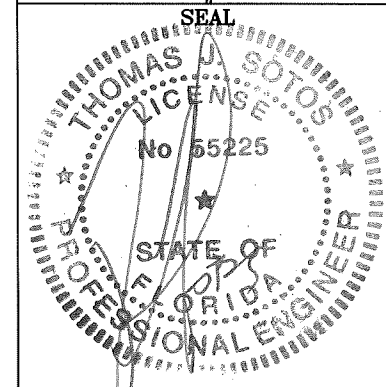

DATE: **NOV 20 2025**

SHEET DESCRIPTION:  
EXTRUSION SECTION  
DRAWINGS & FRAME  
ASSEMBLY DETAIL

DRAWN BY: NELSON ERAZO  
DATE: 11/17/2023

REV. BY: N. E.  
DATE: 11/19/2025

DWG #: CWS-1244  
REV #: A

SCALE: AS NOTED  
SHEET 8 OF 8

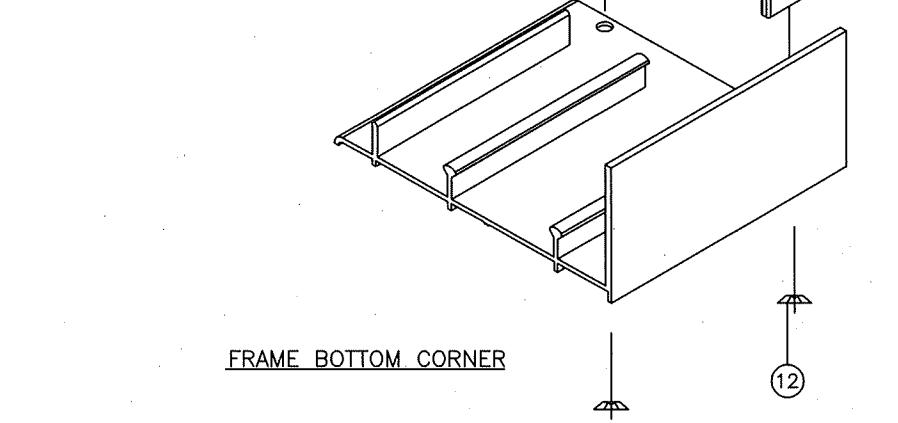
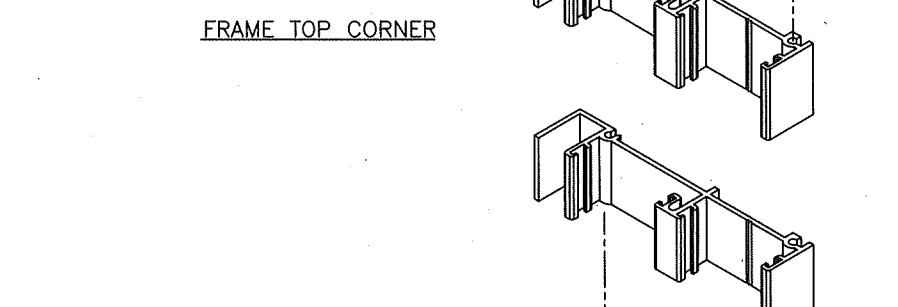
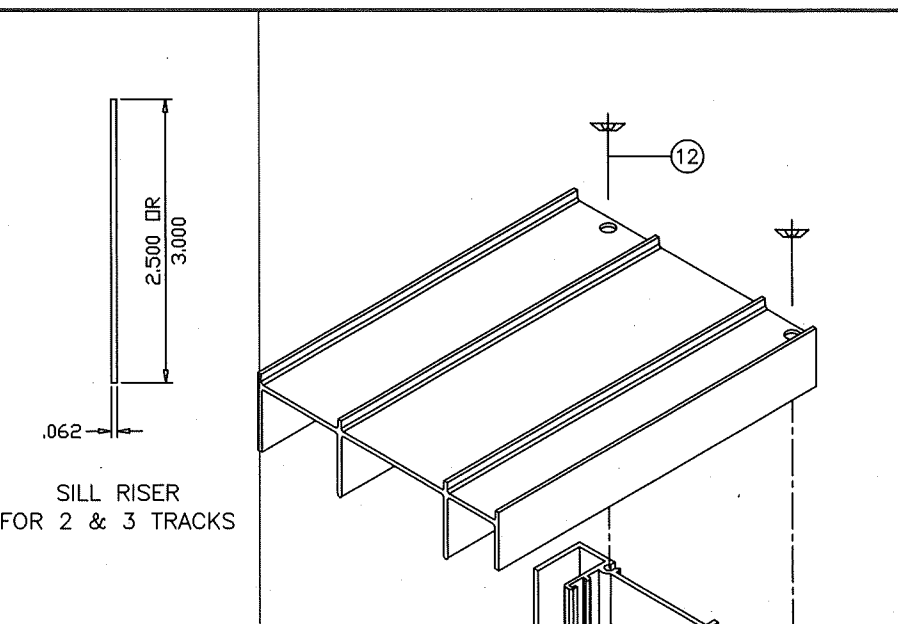
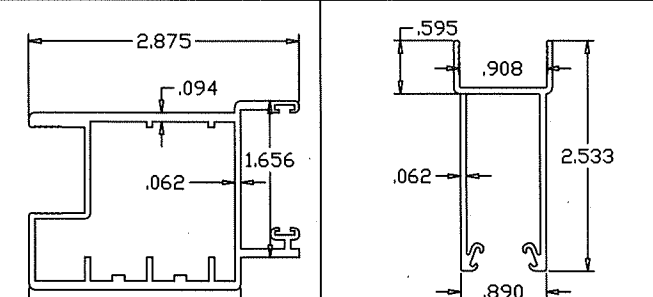
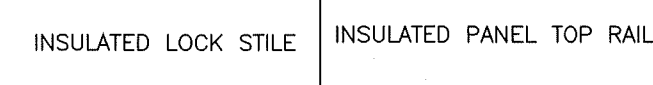
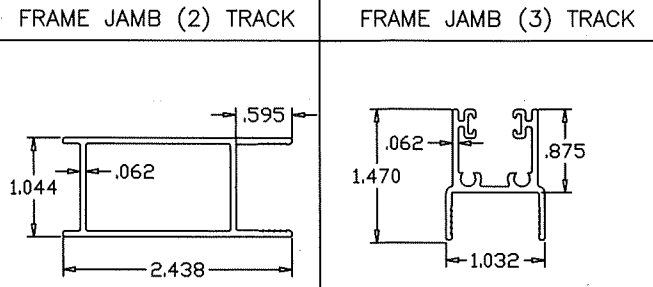
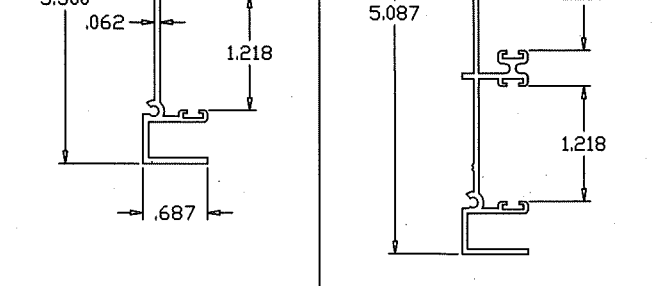
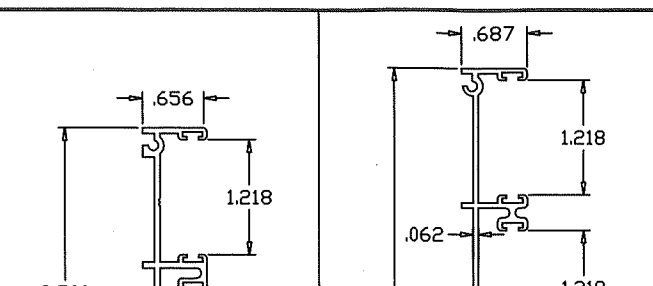
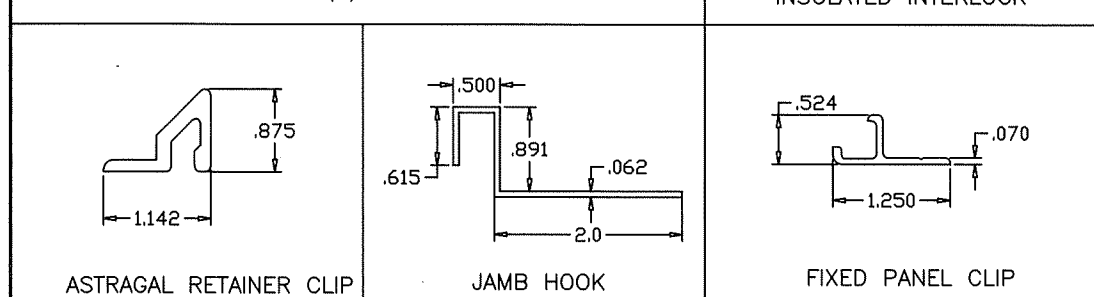
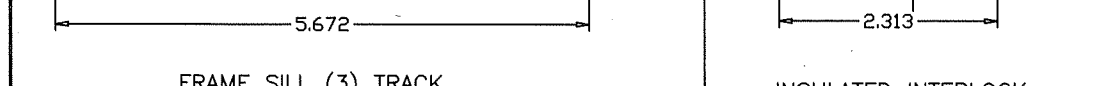
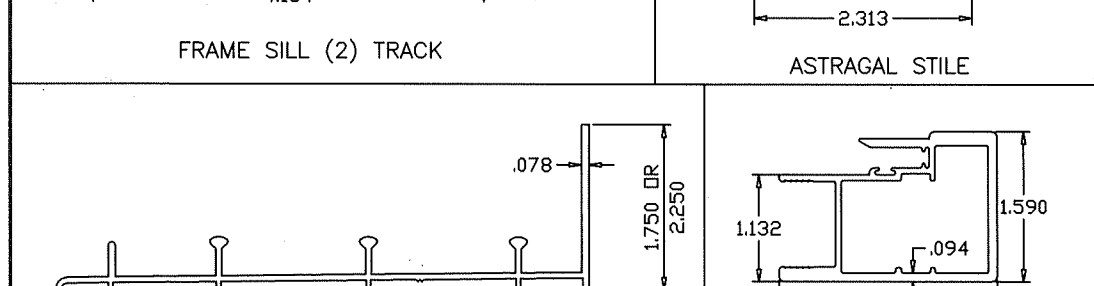
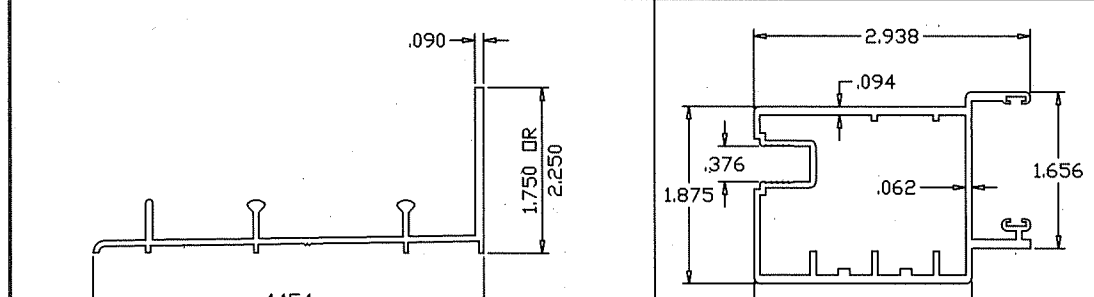
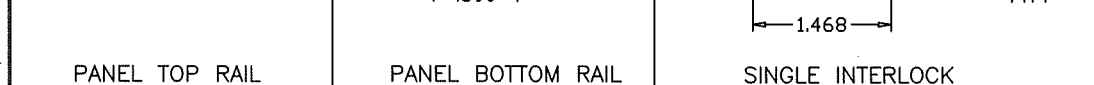
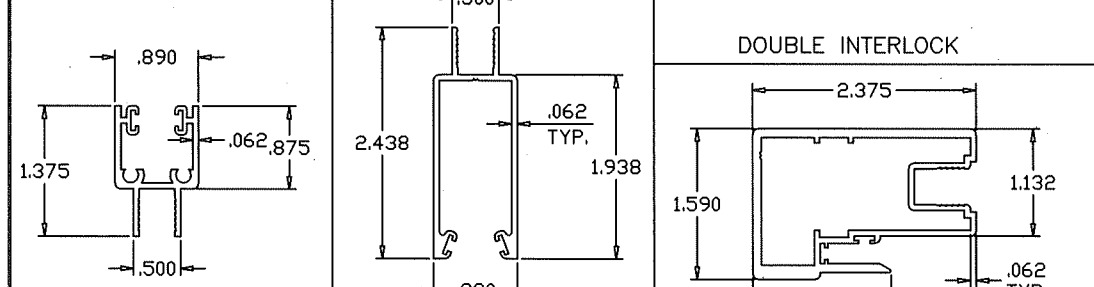
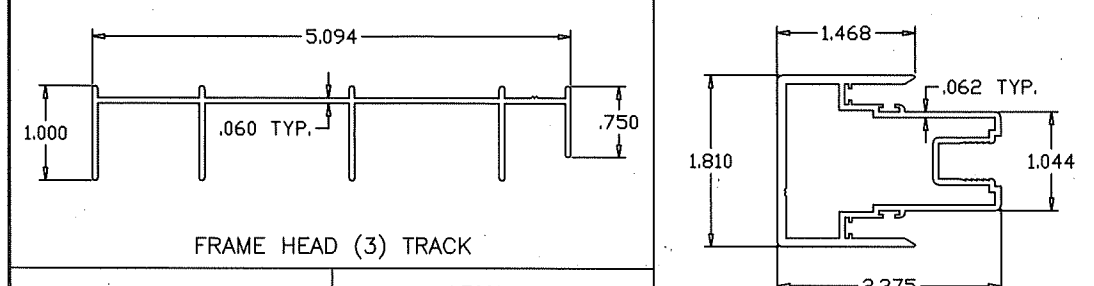
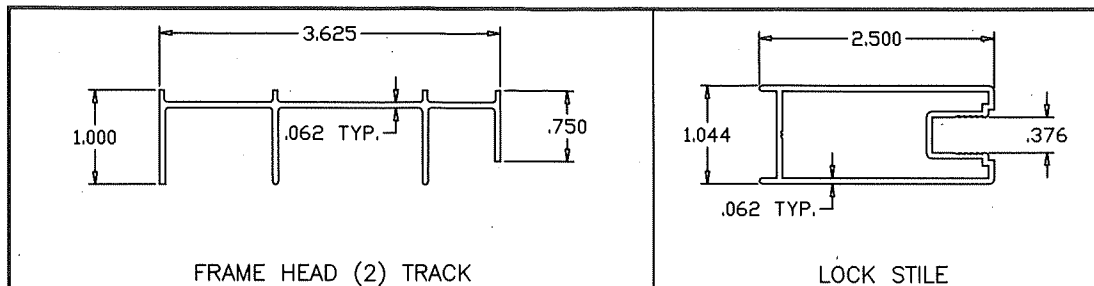

Flexible Vinyl (FPVC) Composition - Team Plastics, Inc.		
<b>*1. FPVC Black: Compound No. 7200-75</b>		
PHYSICAL		ASTM NO.
Durometer Hardness "A", 10 sec	75	D-2240
Specific Gravity	1.45	D-792
Tensile Strength, PSI	1640	D-638
Ultimate Elongation, %	340.0	D-638
Modulus @ 100% Elongation, PSI	765.0	D-638
Impact Brittleness,	-31.0	D-746
<b>*2. FPVC White: Compound No. 7267-75</b>		
PHYSICAL		ASTM NO.
Durometer Hardness "A", 10 sec	75	D-2240
Specific Gravity	1.45	D-792
Tensile Strength, PSI	1640	D-638
Ultimate Elongation, %	325.0	D-638
Modulus @ 100% Elongation, PSI	765.0	D-638
Impact Brittleness,	-30.0	D-746

**PRODUCT REVISED**  
As complying with the Florida  
Building Code  
NOA-No. **25-1201.05**  
Expiration Date: **08/26/2028**  
By: *Manuel Perez*  
Miami-Dade Product Control