



DEPARTMENT OF REGULATORY AND ECONOMIC RESOURCES (RER)  
BOARD AND CODE ADMINISTRATION DIVISION

**NOTICE OF ACCEPTANCE (NOA)**

MIAMI-DADE COUNTY  
PRODUCT CONTROL SECTION  
11805 SW 26 Street, Room 208  
Miami, Florida 33175-2474  
T (786) 315-2590 F (786) 315-2599  
[www.miamidade.gov/economy](http://www.miamidade.gov/economy)

**Custom Window Systems, Inc.**  
1900 SW 44<sup>th</sup> Avenue  
Ocala, FL 34474

**SCOPE:**

This NOA is being issued under the applicable rules and regulations governing the use of construction materials. The documentation submitted has been reviewed and accepted by Miami-Dade County RER - Product Control Section to be used in Miami Dade County and other areas where allowed by the Authority Having Jurisdiction (AHJ).

This NOA shall not be valid after the expiration date stated below. The Miami-Dade County Product Control Section (In Miami-Dade County) and/ or the AHJ (in areas other than Miami-Dade County) reserve the right to have this product or material tested for quality assurance purposes. If this product or material fails to perform in the accepted manner, the manufacturer will incur the expense of such testing and the AHJ may immediately revoke, modify, or suspend the use of such product or material within their jurisdiction. RER reserves the right to revoke this acceptance if it is determined by Miami-Dade County Product Control Section that this product or material fails to meet the requirements of the applicable building code.

This product is approved as described herein and has been designed to comply with the Florida Building Code, including the High Velocity Hurricane Zone.

**DESCRIPTION: Series “CWS-320 (Flange Frame)” Aluminum Horizontal Rolling Window - N.I.**

**APPROVAL DOCUMENT:** Drawing No. **CWS-1256**, titled “CWS 320 Aluminum Flange Frame Non-Impact Horizontal Rolling Window”, sheets 1 through 9 of 9, dated 11/17/23, with revision **B** dated 12/13/25, prepared by the manufacturer, signed and sealed by Thomas J. Sotos, P.E., bearing the Miami-Dade County Product Control Revision stamp with the Notice of Acceptance number and expiration date by the Miami-Dade County Product Control Section.

**MISSILE IMPACT RATING: None**

**LABELING:** Each unit shall bear a permanent label with the manufacturer's name or logo, Medley, Florida, series, and following statement: "Miami-Dade County Product Control Approved", unless otherwise noted herein.

**RENEWAL** of this NOA shall be considered after a renewal application has been filed and there has been no change in the applicable building code negatively affecting the performance of this product.

**TERMINATION** of this NOA will occur after the expiration date or if there has been a revision or change in the materials, use, and/ or manufacture of the product or process. Misuse of this NOA as an endorsement of any product, for sales, advertising or any other purposes shall automatically terminate this NOA. Failure to comply with any section of this NOA shall be cause for termination and removal of NOA.

**ADVERTISEMENT:** The NOA number preceded by the words Miami-Dade County, Florida, and followed by the expiration date may be displayed in advertising literature. If any portion of the NOA is displayed, then it shall be done in its entirety.

**INSPECTION:** A copy of this entire NOA shall be provided to the user by the manufacturer or its distributors and shall be available for inspection at the job site at the request of the Building Official.

This NOA **revises and renews NOA No. 25-0612.03** and consists of this page 1 and evidence pages E-1, E-2, E-3 and E-4, as well as approval document mentioned above.

The submitted documentation was reviewed by **Manuel Perez, P.E.**

  
1/7/26

NOA No. 25-1219.01  
Expiration Date: January 26, 2031  
Approval Date: January 15, 2026  
Page 1

NOTICE OF ACCEPTANCE: EVIDENCE SUBMITTED

**1. EVIDENCE SUBMITTED UNDER PREVIOUS NOA's**

**A. DRAWINGS**

1. Manufacturer's die drawings and sections.  
*(Submitted under NOA No. 09-0720.07)*
2. Drawing No. **CWS-1256**, titled "CWS 320 Aluminum Flange Frame Non-Impact Horizontal Rolling Window", sheets 1 through 9 of 9, dated 11/17/23, with revision **A** dated 05/15/25, prepared by manufacturer, and signed and sealed by Thomas J. Sotos, P.E.  
*(Submitted under NOA No. 25-0612.03)*

**B. TESTS**

1. Test reports on: 1) Uniform Static Air Pressure Test, Loading per FBC, TAS 202-94  
2) Large Missile Impact Test per FBC, TAS 201-94  
3) Cyclic Wind Pressure Loading per FBC, TAS 203-94  
along with marked-up drawings and installation diagram of a series SH-7700 aluminum single hung window and a series PW-4000/6000 aluminum fixed window, prepared by Hurricane Engineering & Testing, Inc., Test Reports No. **HETI-23-8049** and **HETI-23-8048**, both dated 07/24/23, signed and sealed by Ram N. Tewari, P.E.  
*(Submitted under NOA No. 23-1017.08)*
2. Test reports on: 1) Uniform Static Air Pressure Test, Loading per FBC TAS 202-94  
along with marked-up drawings and installation diagram of an aluminum horizontal sliding window, prepared by Hurricane Engineering & Testing Laboratory, Inc., Test Reports No. **HETI-08-2158** and **HETI-08-2160**, dated 09/03/08, both signed and sealed by Candido F. Font, P.E.  
*(Submitted under NOA No. 09-0720.07)*
3. Test reports on: 1) Uniform Static Air Pressure Test, Loading per FBC TAS 202-94  
2) Forced Entry Test, per FBC 2411.3.2.1, and TAS 202-94  
along with marked-up drawings and installation diagram of an aluminum horizontal sliding window, prepared by Hurricane Engineering & Testing Laboratory, Inc., Test Report No. **HETI-08-2159**, dated 09/03/08, signed and sealed by Candido F. Font, P.E.  
*(Submitted under NOA No. 09-0720.07)*
4. Test reports on: 1) Air Infiltration Test, per FBC, TAS 202-94  
2) Uniform Static Air Pressure Test, Loading per FBC, TAS 202-94  
3) Water Resistance Test, per FBC, TAS 202-94  
4) Forced Entry Test, per FBC 2411.3.2.1, and TAS 202-94  
along with marked-up drawings and installation diagram of an aluminum horizontal sliding window, prepared by Fenestration Testing Laboratory, Inc., Test Reports No. **FTL-4413**, dated 06/23/05, **FTL-4429** and **FTL-4541**, dated 06/24/05, all signed and sealed by Edmundo J. Largaespada, P.E.  
*(Submitted under NOA No. 05-0919.05)*

  
Manuel Perez, P.E.  
Product Control Examiner  
NOA No. 25-1219.01  
Expiration Date: January 26, 2031  
Approval Date: January 15, 2026

**NOTICE OF ACCEPTANCE: EVIDENCE SUBMITTED**

**1. EVIDENCE SUBMITTED UNDER PREVIOUS NOA's (CONTINUED)**

**B. TESTS (CONTINUED)**

5. Test reports on: 1) Uniform Static Air Pressure Test, Loading per FBC TAS 202-94  
2) Water Resistance Test, per FBC, TAS 202-94  
along with marked-up drawings and installation diagram of an aluminum horizontal sliding windows, prepared by Fenestration Testing Laboratory, Inc., Test Report No. **FTL-4533**, dated 06/22/05, signed and sealed by Edmundo J. Largaespada, P.E.  
*(Submitted under NOA No. 05-0919.05)*
6. Test reports on: 1) Uniform Static Air Pressure Test, Loading per FBC TAS 202-94  
along with marked-up drawings and installation diagram of an aluminum horizontal sliding window, prepared by Fenestration Testing Laboratory, Inc., Test Reports No. **FTL-4547** dated 06/23/05, **FTL-4457**, **FTL-4578**, **FTL-4588** and **FTL-4594** dated 06/24/05, all signed and sealed by Edmundo J. Largaespada, P.E.  
*(Submitted under NOA No. 05-0919.05)*

**C. CALCULATIONS**

1. Anchor verification calculations and structural analysis, complying with FBC, dated 08/17/05 and 07/16-17/09, prepared by manufacturer, both signed and sealed by Thomas J. Sotos, P.E.  
*(Submitted under NOA No. 10-1025.04)*
2. Glazing complies with **ASTM E1300-04/09**

**D. QUALITY ASSURANCE**

1. Miami-Dade Department of Regulatory and Economic Resources (RER).

**E. MATERIAL CERTIFICATIONS**

1. None.

**F. STATEMENTS**

1. Statement letter of conformance, complying with **FBC 8<sup>th</sup> Edition (2023)**, dated June 9, 2025, issued by the manufacturer, signed and sealed by Thomas J. Sotos, P.E.  
*(Submitted under NOA No. 25-0612.03)*
2. Statement letter of no financial interest, dated June 9, 2025, issued by the manufacturer, signed and sealed by Thomas J. Sotos, P.E.  
*(Submitted under NOA No. 25-0612.03)*
3. Bill of Sales between CWS-SF, LLC (Buyer) and Lawson Industries, Inc. (Seller), dated Nov. 28, 2023, signed by Nicholas Cross (President, CWS) and Harold Bailey (President, Lawson Industries).  
*(Submitted under NOA No. 25-0612.03)*

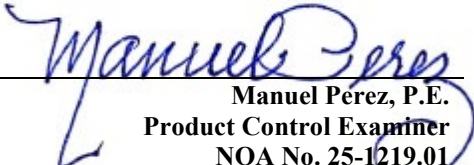
  
Manuel Perez, P.E.  
Product Control Examiner  
NOA No. 25-1219.01  
Expiration Date: January 26, 2031  
Approval Date: January 15, 2026

**Custom Window Systems, Inc.**

**NOTICE OF ACCEPTANCE: EVIDENCE SUBMITTED**

**1. EVIDENCE SUBMITTED UNDER PREVIOUS NOA's (CONTINUED)**  
**F. STATEMENTS (CONTINUED)**

4. Statement letter dated June 5, 2025, confirming that Custom Window System, Inc. is a wholly owned subsidiary of Pella Corporation, signed by Chantel Kramme, Secretary Pella Corp.  
*(Submitted under NOA No. 25-0612.03)*
5. Letter from owners of existing NOA, stating that they have sold all assets to the applicant, that they no longer manufacture the product, relinquish their rights to the current NOA and request that it be rescinded, dated June 10, 2025, signed by Mr. Harold Bailey, President, Lawson Industries, Inc.  
*(Submitted under NOA No. 25-0612.03)*
6. Statement letter dated June 25, 2025, issued by Custom Window Systems, Inc. (CWS) stating that they have legally purchased all assets of (18) listed NOA's from Lawson Industries, Inc. and requesting that new corresponding NOA's be issued to CWS name; also, that (18) listed Private Label Agreement NOA's between Lawson Industries, Inc. and CWS be rescinded, signed by Kevin Pine, Vice President.  
*(Submitted under NOA No. 25-0612.03)*
7. Proposal No. **23-0461R** issued by Product Control Section, dated June 13, 2023, and revised on June 16, 2023, signed by Manuel Perez, P.E.  
*(Submitted under NOA No. 23-1017.08)*
8. Laboratory compliance letter for Test Reports No. **HETI-08-2158, HETI-08-2159, and HETI-08-2160**, dated 09/03/08, all issued by Hurricane Engineering & Testing Laboratory, Inc., signed and sealed by Candido F. Font, P.E.  
*(Submitted under NOA No. 09-0720.07)*
9. Laboratory compliance letter for Test Reports No. , **FTL-4533, FTL-4553** dated 06/22/05, **FTL-4413, FTL-4456, FTL-4547**, dated 06/23/05, **FTL-4429, FTL-4457, FTL-4541, FTL-4578, FTL-4588, FTL-4594** dated 06/24/05, all issued by Fenestration Testing Laboratory, Inc., signed and sealed by Edmundo J. Largaespada, P.E.  
*(Submitted under NOA No. 05-0919.04)*

**G. OTHERS**

1. Notice of Acceptance No. **23-1017.08**, issued to Lawson Industries, Inc. for their Series "HS-8500 (Flange Frame)" Aluminum Horizontal Rolling Window – N.I., approved on 11/16/23 and expiring on 01/26/26.
2. Notice of Acceptance No. **24-0116.16**, issued to Custom Window Systems, Inc. for their Series "CWS-320 (Flange Frame)" Aluminum Horizontal Rolling Window – N.I., approved on 02/01/24 and expiring on 01/26/26. **(Private Label NOA already rescinded)**

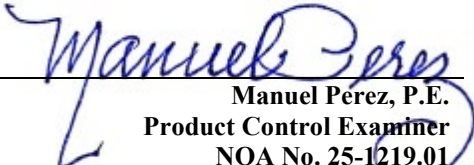
  
Manuel Perez, P.E.  
Product Control Examiner  
NOA No. 25-1219.01  
Expiration Date: January 26, 2031  
Approval Date: January 15, 2026

**Custom Window Systems, Inc.**

**NOTICE OF ACCEPTANCE: EVIDENCE SUBMITTED**

**2. NEW EVIDENCE SUBMITTED**

**A. DRAWINGS**

1. Drawing No. **CWS-1256**, titled “CWS 320 Aluminum Flange Frame Non-Impact Horizontal Rolling Window”, sheets 1 through 9 of 9, dated 11/17/23, with revision **B** dated 12/13/25, prepared by manufacturer, and signed and sealed by Thomas J. Sotos, P.E.

**B. TESTS**

1. None.

**C. CALCULATIONS**

1. None.

**D. QUALITY ASSURANCE**

1. Miami-Dade Department of Regulatory and Economic Resources (RER)

**E. MATERIAL CERTIFICATIONS**

1. None.

**F. STATEMENTS**

1. Statement letter of conformance, complying with **FBC 8<sup>th</sup> Edition (2023)**, dated December 16, 2025, issued by the manufacturer, signed and sealed by Thomas J. Sotos, P.E.
2. Statement letter of no financial interest, dated December 16, 2025, issued by the manufacturer, signed and sealed by Thomas J. Sotos, P.E.

**G. OTHERS**

1. Notice of Acceptance No. **25-0612.03**, issued to Custom Window Systems, Inc. for their Series “320 (Flange Frame)” Aluminum Horizontal Rolling Window – N.I., approved on 07/10/25 and expiring on 01/26/26.

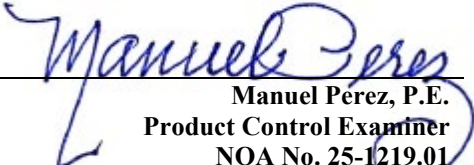
  
Manuel Perez, P.E.  
Product Control Examiner  
NOA No. 25-1219.01  
Expiration Date: January 26, 2031  
Approval Date: January 15, 2026

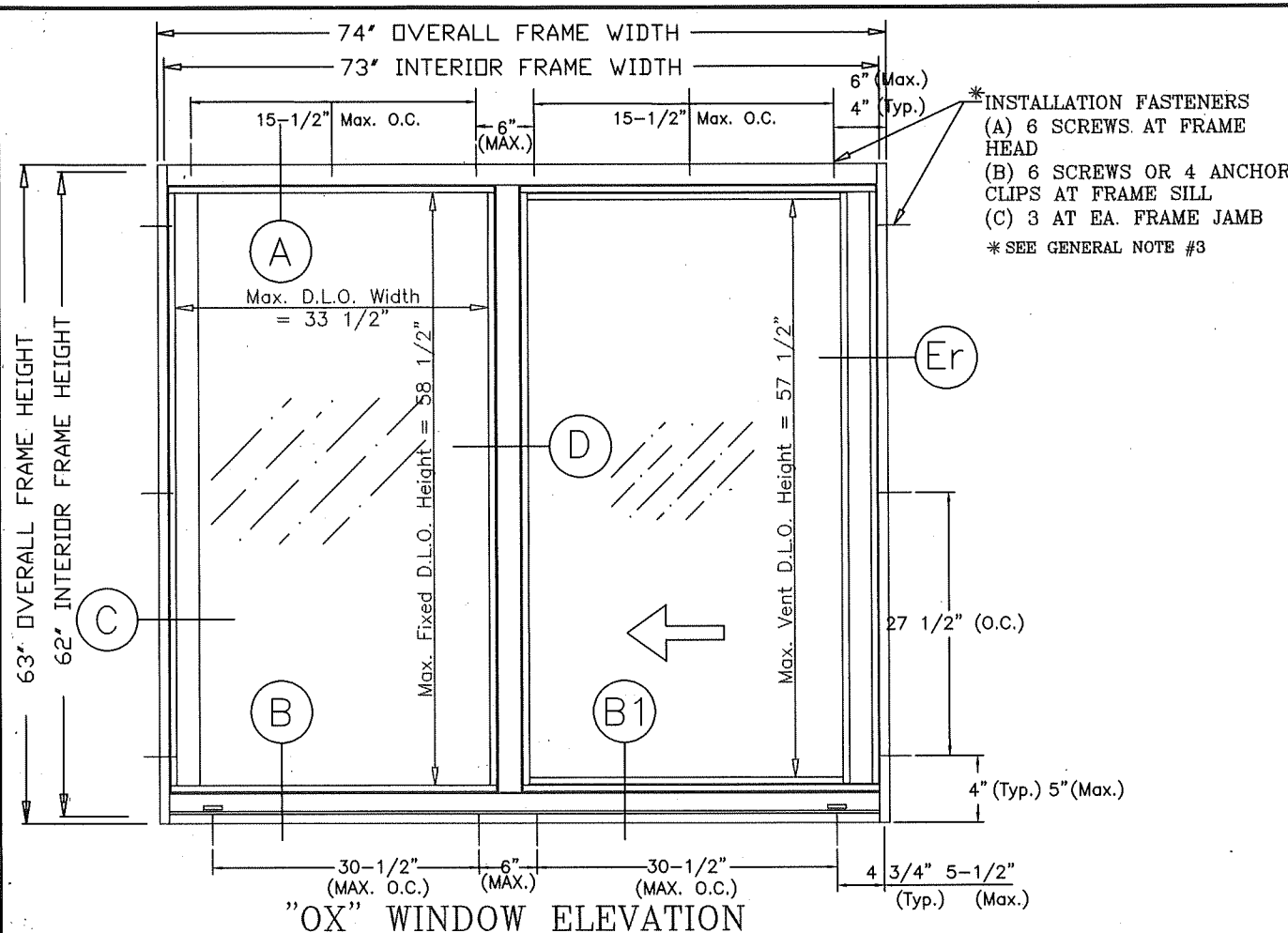

"OX" WINDOW ELEVATION

**General Notes:**

- 1.) THIS WINDOW SYSTEM IS DESIGNED AND TESTED TO COMPLY WITH THE REQUIREMENTS OF THE FLORIDA BUILDING CODE (2023-8th Edition) AND ASTM 1300-16. THIS PRODUCT IS NOT IMPACT RESISTANT AND WINDOWS ARE TO BE PROTECTED WITH A MIAMI-DADE COUNTY APPROVED IMPACT RESISTANT SHUTTER.
- 2.) 1 X OR 2 X WOOD BUCKS SHALL BE INSTALLED AND ANCHORED SO THAT THE BUILDING RESISTS THE SUPERIMPOSED LOADS IN ACCORDANCE WITH THE REQUIREMENTS OF THE FBC & TO BE REVIEWED BY BUILDING OFFICIAL.
- 3.) ANCHORS SHOWN ABOVE ARE AS PER TEST UNITS. ON CENTER (O.C.) ANCHOR SPACINGS WILL VARY WITH UNIT DIMENSIONS, AND THE NUMBER OF ANCHORS REQUIRED, AS SPECIFIED ON THE LOAD TABLES.
- 4.) ANCHOR CONDITIONS NOT DESCRIBED IN THESE DRAWING'S ARE TO BE ENGINEERED ON A SITE SPECIFIC BASIS, UNDER SEPARATE APPROVAL AND TO BE REVIEWED BY BUILDING OFFICIAL.
- 5.) FRAME INSTALLATION SHIMS IF USED; SHALL BE LOAD BEARING.
- 6.) XO or OX WINDOWS ARE QUALIFIED FOR USE WITH SINGLE GLAZE GLASS TYPES TABULATED HEREIN (SEE SHEET # 5 & 6).
- 7.) XOx WINDOWS ARE QUALIFIED FOR USE WITH SINGLE GLAZE GLASS TYPES TABULATED HEREIN (SEE SHEET #7).
- 8.) XO, OX, XOx WINDOWS ARE QUALIFIED FOR USE WITH DOUBLE GLAZE GLASS TYPES TABULATED HEREIN (SEE SHEET #8).
- 9.) SEE SHEET 4 FOR LOCK DETAILS & OPTIONS.
- 10.) SEE SHEET 4 FOR GLAZING DETAILS & OPTIONS (REFER TO SHEETS 5, 6, 7 & 8 FOR DESIGN PRESSURES).
- 11.) TEMPERED GLASS MAY BE USED, BUT DESIGN PRESSURES ARE LIMITED TO LOAD TABLES ON SHEET # 6 FOR XO UNITS AND SHEETS # 7 & 8 FOR XOx UNITS.
- 12.) FRAME SILL ANCHOR CLIPS TO BE MEASURED FROM THE INSIDE EDGE OF THE WINDOW FRAME AND TO BE LOCATED WITHIN A +/- 1/4" TOLERANCE. ANCHORS REQUIRED AT FRAME SILL TO BE THE SAME AS FRAME HEAD.
- 13.) SEE SHEET #6 FOR FLANGE PERIMETER CAULK/ INSTALLATION DETAIL.
- 14.) APPROVAL APPLIES TO SINGLE UNITS OR MULTIPLE UNITS AND MAY BE MULLED HORIZONTALLY OR VERTICALLY.
- 15.) MULLING SINGLE HUNG WINDOWS WITH OTHER TYPES OF MIAMI-DADE COUNTY APPROVED WINDOWS USING A MIAMI-DADE COUNTY APPROVED MULLION IN BETWEEN ARE ACCEPTABLE BUT THE LOWER DESIGN PRESSURE FROM THE WINDOWS OR MULLION APPROVAL WILL APPLY TO THE ENTIRE MULLED SYSTEM.
- 16.) SEE SHEET # 9 FOR MULLION/METAL ATTACHMENT DETAILS & NOTES.

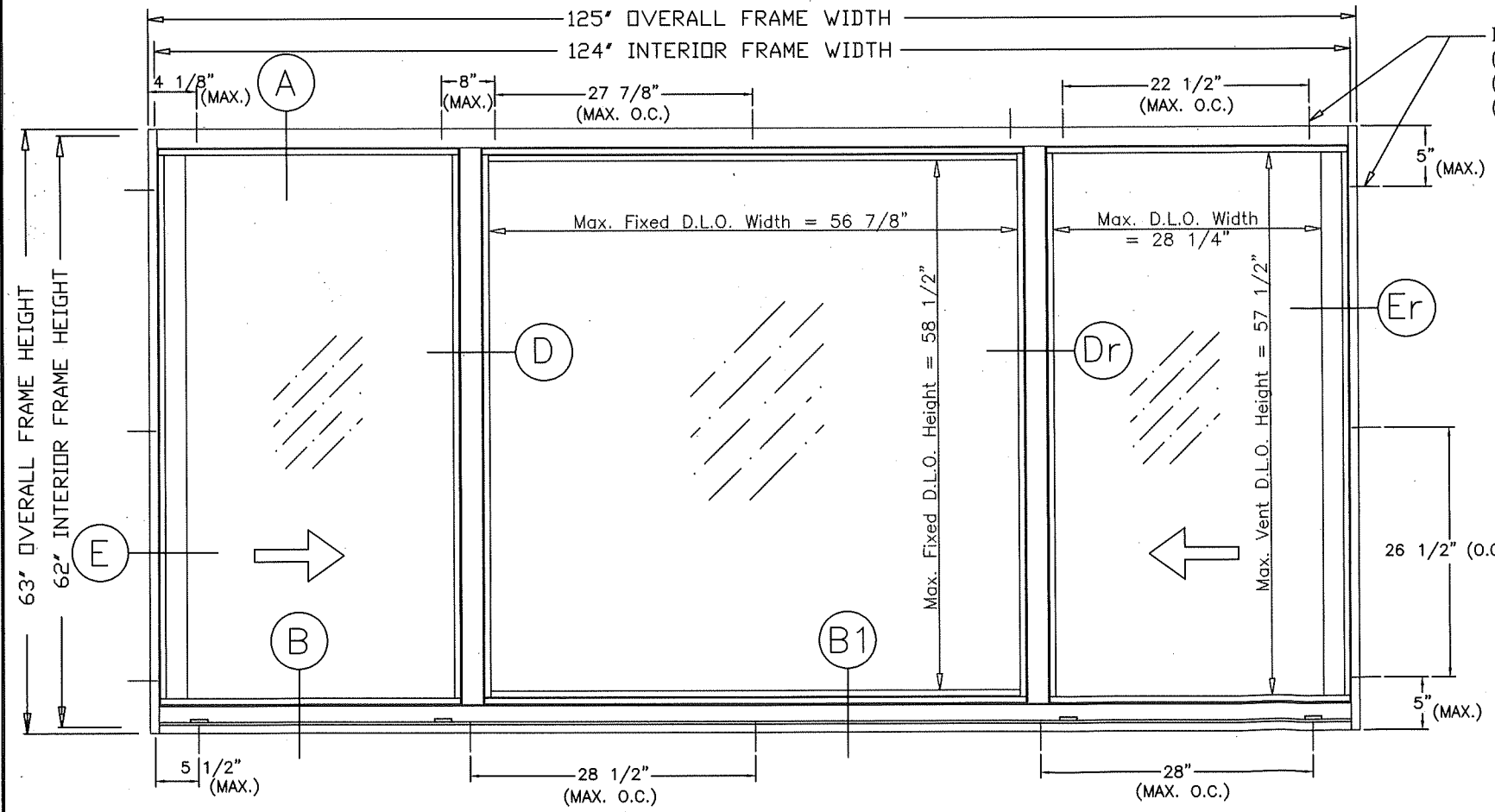

"XOX" WINDOW ELEVATION

INSTALLATION FASTENERS\*  
 (A) 7 AT FRAME HEAD  
 (B) 5 AT FRAME SILL  
 (C) 3 AT EA. FRAME JAMB  
 \* SEE GENERAL NOTE #3

WINDOWS ARE TO BE PROTECTED WITH MIAMI-DADE COUNTY APPROVED IMPACT RESISTANT SHUTTERS

**CWS 320 ALUM. HORIZONTAL SLIDING WINDOW  
 FLANGE FRAME - (NON-IMPACT)**

**PRODUCT REVISED**  
 As complying with the Florida Building Code  
 NOA-No. **25-1219.01**  
 Expiration Date: **01/26/2031**  
 By: *Manuel Perez*  
 Miami-Dade Product Control



**CWS 320 ALUMINUM  
 FLANGE FRAME NON-IMPACT  
 HORIZONTAL ROLLING WINDOW**

NO.	DESCRIPTION	BY	DATE
B	Revises NDA # 22-0612.03	NE	12/13/25
A	Revises NDA # 23-1017.08	NE	05/15/25

THOMAS J. SOTOS  
 PROFESSIONAL ENGINEER  
 FL LIC. # 55225

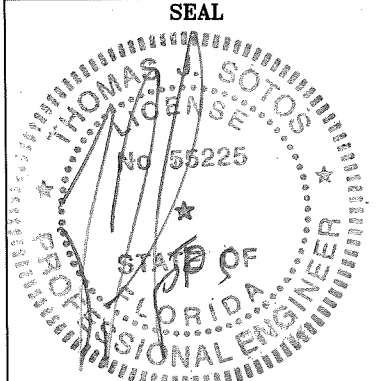

DATE **DEC 15 2025**

SHEET DESCRIPTION:  
 APPROVED ELEVATIONS,  
 CONFIGURATIONS AND  
 NOTES

DRAWN BY:	DATE:
NELSON ERAZO	11/17/2023
REV. BY:	DATE:
N.E.	05/15/2025
DWG #:	REV #:
CWS-1256	B
SCALE:	SHEET
AS NOTED	1 OF 9

**CWS 320 ALUMINUM  
FLANGE FRAME NON-IMPACT  
HORIZONTAL ROLLING WINDOW**

NO.	DESCRIPTION	BY	DATE
B	Revises NOA # 22-0612.03	N.E.	12/13/25
A	Revises NOA # 23-1017.08	N.E.	05/15/25

THOMAS J. SOTOS  
PROFESSIONAL ENGINEER  
FL LIC. # 55225

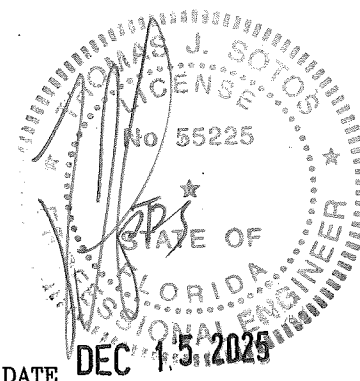

DATE: DEC 15, 2025  
SHEET DESCRIPTION:  
**WINDOW VERTICAL CROSS SECTION & DETAILS**

DRAWN BY:	DATE:
NELSON ERAZO	11/17/2023
REV. BY:	DATE:
N.E.	05/15/2025
DWG #:	REV #:
CWS-1256	B
SCALE:	SHEET
AS NOTED	2 OF 9

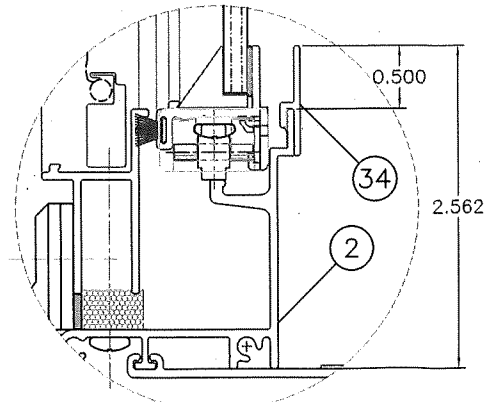
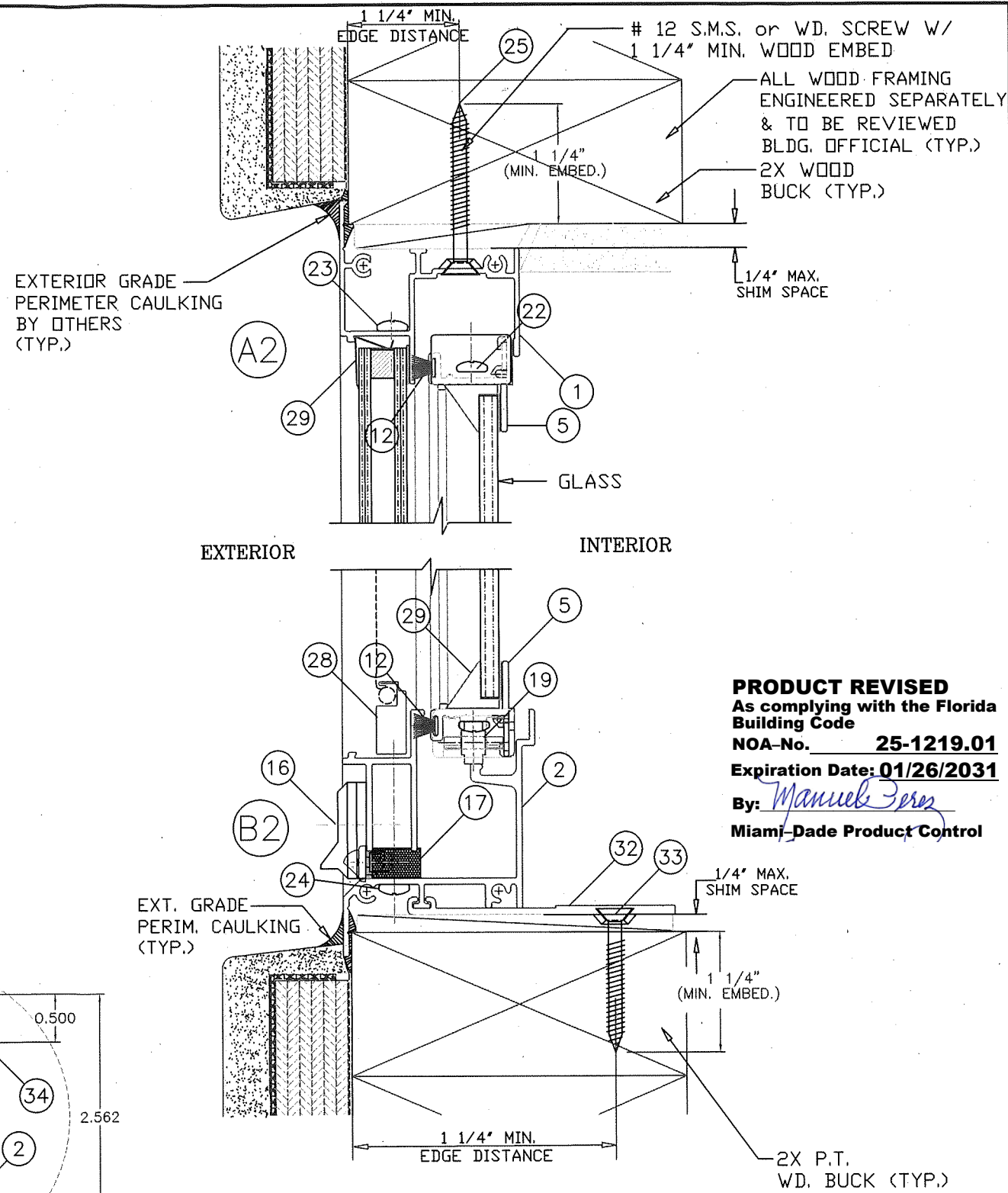
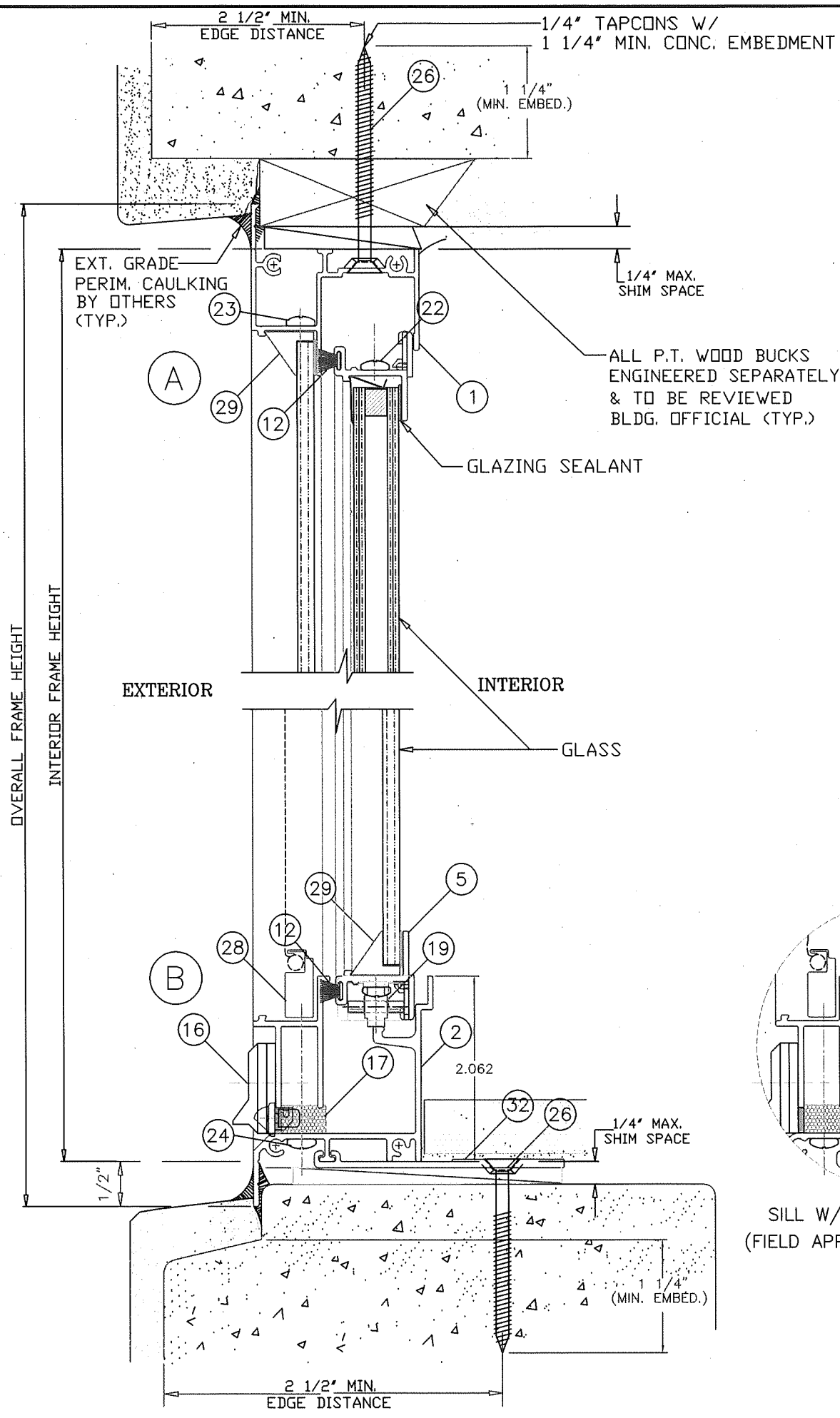

SILL W/ 1/2" RISER ADAPTER  
(FIELD APPLIED W/ CLEAR SILICONE)

**ANCHORS NOTE:**  
ANCHORS TO BE #12 SMS OR WD. SCREWS INTO WOOD, OR 1/4" TAPCONS or APPROVED CONC. FASTENERS INTO CONC., WITH A MINIMUM OF 1 1/4" PENETRATION INTO WOOD OR CONC. (REFER TO LOAD TABLES FOR QUANTITIES REQUIRED)

\* WHEN THE GAP BETWEEN THE WINDOW FRAME AND THE BUCK OR MASONRY IS LESS THAN 1/8", SHIMS ARE NOT REQUIRED.

**PRODUCT REVISED**  
As complying with the Florida Building Code  
NOA-No. **25-1219.01**  
Expiration Date: **01/26/2031**  
By: *Manuel Fern*  
Miami-Dade Product Control

REVISIONS

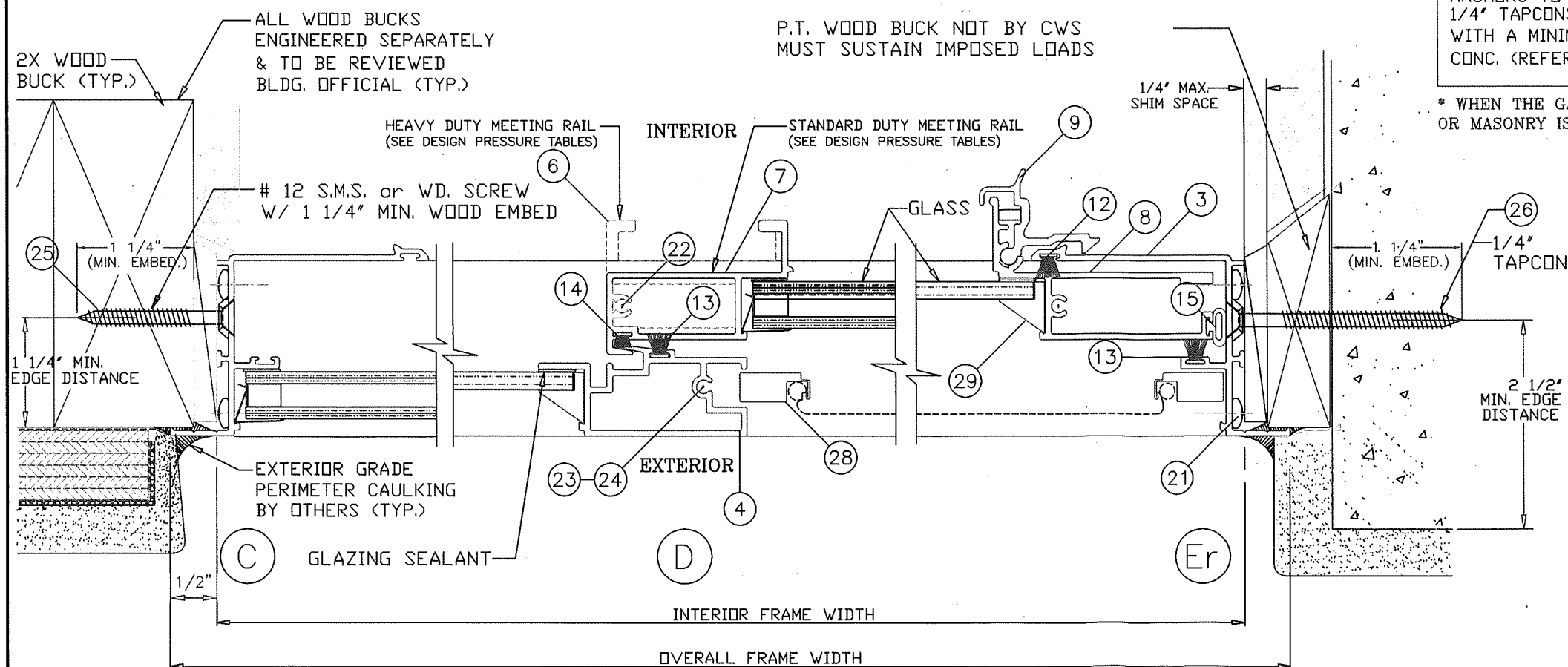
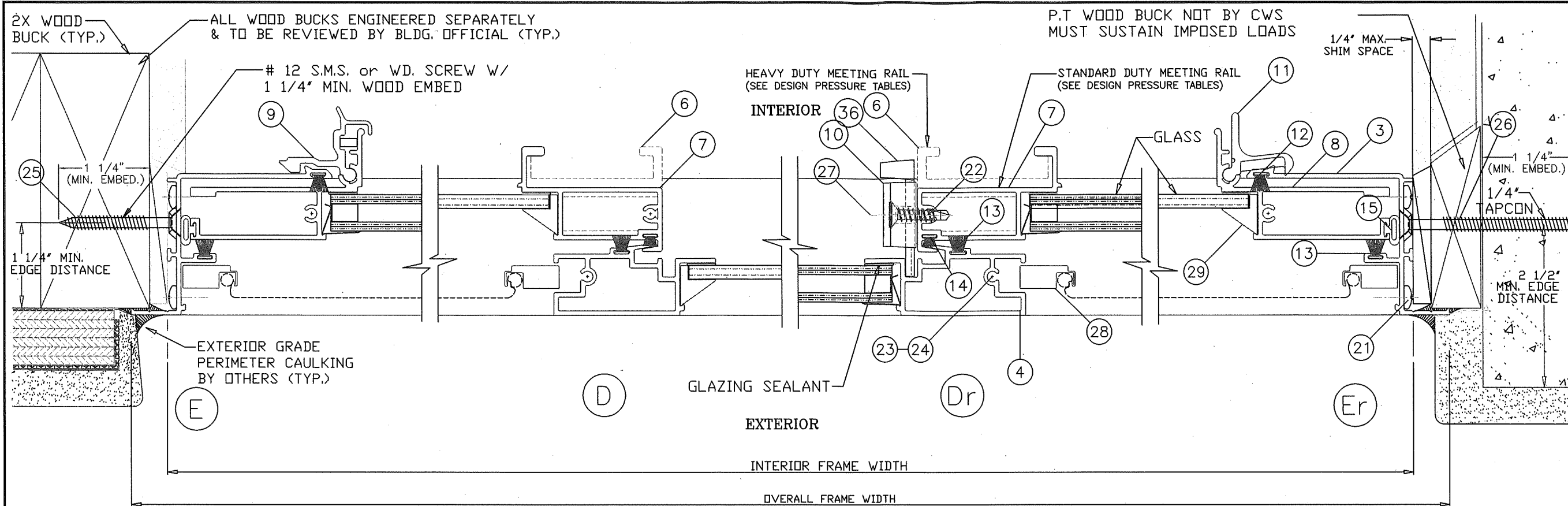

**ANCHORS NOTE:**  
 ANCHORS TO BE #12 SMS OR WD. SCREWS INTO WOOD, OR 1/4" TAPCONS or APPROVED CONC. FASTENERS INTO CONC., WITH A MINIMUM OF 1 1/4" PENETRATION INTO WOOD OR CONC. (REFER TO LOAD TABLES FOR QUANTITIES REQUIRED)  
 \* WHEN THE GAP BETWEEN THE WINDOW FRAME AND THE BUCK OR MASONRY IS LESS THAN 1/8", SHIMS ARE NOT REQUIRED.

1900 SW 44TH AVE.  
 Ocala, Florida 34474  
 WWW.CWS.CC

**CWS 320 ALUMINUM  
 FLANGE FRAME NON-IMPACT  
 HORIZONTAL ROLLING WINDOW**

NO.	DESCRIPTION	BY	DATE
B	Revises NOA # 22-0612.03	N.E.	12/13/25
A	Revises NOA # 23-1017.08	N.E.	05/15/25

**THOMAS J. SOTOS  
 PROFESSIONAL ENGINEER  
 FL LIC. # 55225**

SEAL

DATE: DEC 15 2025

SHEET DESCRIPTION:  
**HORIZONTAL CROSS SECTIONAL DETAILS FOR STD/HVY DUTY MEETING RAIL**

DRAWN BY:	DATE:
NELSON ERAZO	11/17/2023
REV. BY:	DATE:
N.E.	05/15/2025
DWG #:	REV #:
CWS-1256	B
SCALE:	SHEET
AS NOTED	3 OF 9

**PRODUCT REVISED**  
 As complying with the Florida Building Code  
 NOA-No. **25-1219.01**  
 Expiration Date: **01/26/2031**  
 By: *Manuel Perez*  
 Miami-Dade Product Control

CWS 320 FLANGE HRW WINDOW - BILL OF MATERIALS

ITEM #	PART #	DRWG. #	REQD.	DESCRIPTION	REMARKS
1	L-7503	*	1	FRAME HEAD	6063-T6 ALUMINUM
2	L-8501	*	1	FRAME SILL	6063-T5 ALUMINUM
3	L-8502	*	2	FRAME JAMB	6063-T6 ALUMINUM
4	L-7504	*	1 x frame	FIXED MEETING RAIL	6005-T6 ALUMINUM
5	L-7508	*	2 x vent	VENT TOP / BOTTOM RAIL	6063-T5 ALUMINUM
6	L-7506	*	1 x vent	VENT INTERLOCK RAIL-H.D.	6005-T6 ALUMINUM
7	L-7505	*	1 x vent	VENT INTERLOCK STD. DUTY	6005-T5 ALUMINUM
8	L-7507	*	1 x vent	VENT LATCH JAMB	6005-T6 ALUMINUM
9	*	*	2 x vent	VENT EXTRUDED LOCK	6063-T5 ALUMINUM
10	*	*	2 x vent	VENT CAM LOCK	DIE-CAST CAM LOCK
11	*	HC-057	2 x vent	VENT PLASTIC LOCK	SPRING LOADED
12	*	SCHLEGEL	AS REQD.	Top/Bott. Rail Weatherstrip	.187' X .280' FIN SEAL
13	*	ULTRAFAB	AS REQD.	FXD. RAIL WEATHERSTRIP	.187' X 250' FIN SEAL
14	*	ULTRAFAB	AS REQD.	VENT LOCK WEATHERSTRIP	.187' X 150' PILE
15	*	*	AS REQ'D.	VENT JAMB WEATHERSTRIP	3/8' DIA. BULB
16	*	*	2	WEEP HOLE COVER W/ FLAP	1 1/2' wide x 1/4' hl weep
17	*	*	2	SILL OPEN CELL FOAM PAD	1/2"x3/8"x 1 3/4' LONG
18	*	*	2	SILL/JAMB JOINT GASKET	1/16' CLOSED CELL FOAM
19	L-763	HC-032	2	VENT ROLLER ASSEMBLY	2 X VENT BOTTOM RAIL
20	L-7524	*	6	VENT FACE GUIDE	3 PER VENT HDR. RAIL
21	*	*	8	FRAME ASSEMBLY SCREWS	# 8 X 1' P.H. SQ. RECESS
22	*	*	4 x vent	VENT ASSEMBLY SCREWS	# 8 X 1' P.H. SQ. RECESS
23	*	*	1 X RAIL	MTG. RAIL SCREW @ HEAD	# 8 X 1' P.H. SQ. RECESS
24	*	*	1 X RAIL	MTG. RAIL SCREW @ SILL	# 8 X 2' P.H. SQ. RECESS
25	*	*	SEE CHART	FRAME INSTALL'N SCREW	#12 X 1 1/2' F.H.-PHI.-S.M.S
26	*	*	SEE CHART	FRAME INSTALL'N SCREW	1/4' X 1 3/4' F.H.-TAPCON
27	*	*	2 X LOCK	CAM LOCK ATTCH'NT SCREW	#8 X 7/8' F.H. / PHI.
28	*	*	1 x vent	INSECT SCREEN	*
29	*	*	AS REQD.	GLAZING BEAD	ROLL FORMED ALUMINUM
30	*	*	AS REQ'D.	GLASS	See Detail @sheet 4 of 8
31	*	*	AS REQ'D	GLAZING SILICONE	See Detail @ sheet 4 of 8
32	L-8730	051872	1x anchor	SILL ANCHOR CLIP- 2'Long	6063-T6 ALUMINUM
33	*	*	5	FRAME SILL INST'N SCREW	#12 X 1 3/4' F.H. / PHI.
34	L-8503	LII-132	1	FRAME SILL 1/2' RISER	6063-T6 ALUMINUM
35 a	TruSeal	*	AS REQ'D.	Swiggle Seal Spacer	Black -1/4' air space
35 b	Quanex	*	AS REQ'D	SuperSpacer w/ Isomelt M	Black -1/4' air space
35 c	Quanex	*	AS REQ'D	Duraseal Spacer	Black -1/4' air space
36	HC-058-1	*	2 x vent	VENT SWEEP LATCH/LOCK	MOLDED NYLON
37	SEALANT	SEALANT	AS REQ'D	ACRYL-R JOINT SEALANT	SM-5504/5591

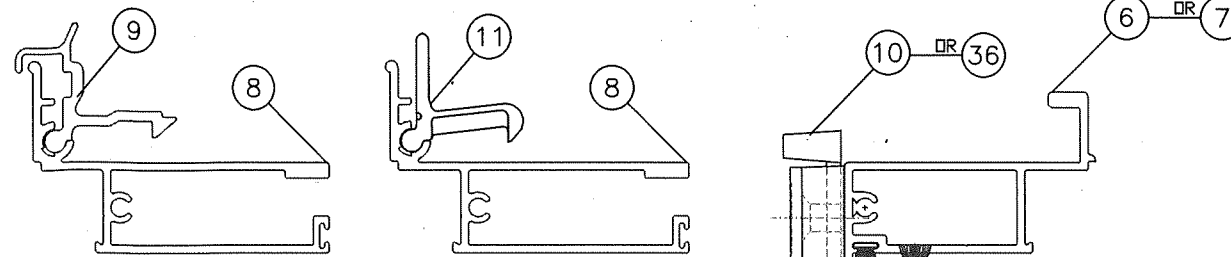

Notes

- BOTH EXTRUDED ALUMINUM AND PLASTIC LIFT HANDLE LOCKS ARE QUALIFIED FOR USE ON ALL WINDOWS.
- BOTH DIE CAST METAL AND MOLDED PLASTIC CAM LOCKS ARE QUALIFIED FOR USE ON ALL WINDOWS
- TWO (2) LOCKS ARE REQUIRED PER EACH VENT.

LOCK (LATCH AND SWEEP) OPTIONS

Glazing Detail & Description

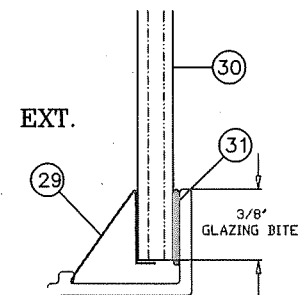

MONOLITHIC GLASS - SINGLE GLAZE  
ANNEALED OR TEMPERED  
1/8", 3/16" OR 1/4" THICK  
(SEE DESIGN PRESSURE TABLES)

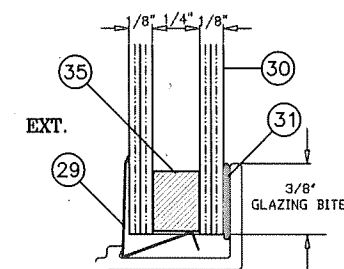

1/2" OVERALL INSULATED GLASS  
CONSIST OF:  
1/8" ANNEALED OR TEMPERED LITE  
+ 1/4" AIR SPACE  
+ 1/8" ANNEALED OR TEMPERED LITE  
(SEE DESIGN PRESSURE TABLES)

31) Glazing Sealant Types & Options

- Schnee-Morehead 5731
- Schnee-Morehead 5732
- GE SCS 1000 Clear Silicone
- Dow Corning Clear Silicone

35) Insulated Spacer Types & Options

- 35a) TrueSeal Swiggle Seal
- 35b) Quanex SuperSpacer w/ Isomelt M
- 35c) Quanex Duraseal



1900 SW 44TH AVE.  
OCALA, FLORIDA 34474  
WWW.CWS.CC

CWS 320 ALUMINUM  
FLANGE FRAME NON-IMPACT  
HORIZONTAL ROLLING WINDOW

NO.	DESCRIPTION	BY	DATE
B	Revises NOA # 22-061203	N.E.	12/13/25
A	Revises NOA # 23-101708	N.E.	05/15/25

THOMAS J. SOTOS  
PROFESSIONAL ENGINEER  
FL LIC. # 55225

SEAL

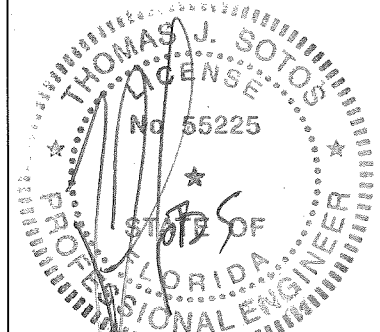

DATE DEC 15 2025

SHEET DESCRIPTION:  
BILL OF MATERIALS,  
GLAZING DETAILS & LOCK  
OPTIONS

DRAWN BY: NELSON ERAZO DATE: 11/17/2023

REV. BY: N.E. DATE: 05/15/2025

DWG #: CWS-1256 REV #: A

SCALE: AS NOTED SHEET 4 OF 9

**PRODUCT REVISED**  
As complying with the Florida  
Building Code  
NOA-No. 25-1219.01  
Expiration Date: 01/26/2031  
By: *Manuel Perez*  
Miami-Dade Product Control

8500 Non Impact Horizontal Sliding Window Test # FTL 4413 - 1/4" Annealed Flange Frame (XO or OX) w/ HEAVY DUTY MEETING RAIL & STANDARD SILL					
Width (in)	Height (in)	DP(+) psf	DP(-) psf	Anchors	
				Head & Sill	Each Jamb
26.5	26	60.0	100.0	2	2
37	26	60.0	100.0	2	2
53.125	26	60.0	100.0	3	2
74	26	60.0	100.0	5	2
26.5	38.375	60.0	100.0	2	2
37	38.375	60.0	100.0	3	2
53.125	38.375	60.0	100.0	4	2
74	38.375	60.0	100.0	6	2
26.5	50.625	60.0	100.0	2	2
37	50.625	60.0	100.0	3	2
53.125	50.625	60.0	89.6	4	3
74	50.625	60.0	74.8	5	3
26.5	58	60.0	100.0	3	2
37	58	60.0	98.6	4	3
53.125	58	60.0	74.9	4	3
74	58	60.0	60.8	5	3
26.5	63	60.0	100.0	3	2
37	63	60.0	89.4	3	3
53.125	63	60.0	67.3	4	3
74	63	54.0	54.0	5	3
24	24	60.0	100.0	2	2
36	24	60.0	100.0	2	2
48	24	60.0	100.0	3	2
60	24	60.0	100.0	3	2
72	24	60.0	100.0	4	2
24	36	60.0	100.0	2	2
36	36	60.0	100.0	3	2
48	36	60.0	100.0	3	2
60	36	60.0	100.0	4	2
72	36	60.0	100.0	5	2
24	48	60.0	100.0	2	2
36	48	60.0	100.0	3	2
48	48	60.0	100.0	4	3
60	48	60.0	89.8	5	3
72	48	60.0	82.3	5	3
24	60	60.0	100.0	2	2
36	60	60	96.9	4	3
48	60	60	77.2	4	3
60	60	60	65.9	4	3
72	60	58.8	58.8	5	3

Pressure Limited to Negative 100psf.

8500 Non Impact Horizontal Sliding Window Test # FTL 4413 - 1/4" Annealed Flange Frame (XO or OX) w/ HEAVY DUTY MEETING RAIL & HI-RISE SILL					
Width (in)	Height (in)	DP(+) psf	DP(-) psf	Anchors	
				Head & Sill	Each Jamb
26.5	26	73.3	100.0	2	2
37	26	73.3	100.0	2	2
53.125	26	73.3	100.0	3	2
74	26	73.3	100.0	5	2
26.5	38.375	73.3	100.0	2	2
37	38.375	73.3	100.0	3	2
53.125	38.375	73.3	100.0	4	2
74	38.375	73.3	100.0	6	2
26.5	50.625	73.3	100.0	2	2
37	50.625	73.3	100.0	3	2
53.125	50.625	73.3	89.6	4	3
74	50.625	73.3	74.8	5	3
26.5	58	73.3	100.0	3	2
37	58	73.3	98.6	4	3
53.125	58	73.3	74.9	4	3
74	58	60.8	60.8	5	3
26.5	63	73.3	100.0	3	2
37	63	73.3	89.4	3	3
53.125	63	67.3	67.3	4	3
74	63	54.0	54.0	5	3
24	24	73.3	100.0	2	2
36	24	73.3	100.0	2	2
48	24	73.3	100.0	3	2
60	24	73.3	100.0	3	2
72	24	73.3	100.0	4	2
24	36	73.3	100.0	2	2
36	36	73.3	100.0	3	2
48	36	73.3	100.0	3	2
60	36	73.3	100.0	4	2
72	36	73.3	100.0	5	2
24	48	73.3	100.0	2	2
36	48	73.3	100.0	3	2
48	48	73.3	100.0	4	3
60	48	73.3	89.8	5	3
72	48	73.3	82.3	5	3
24	60	73.3	100.0	2	2
36	60	73.3	96.9	4	3
48	60	73.3	77.2	4	3
60	60	65.9	65.9	4	3
72	60	58.8	58.8	5	3

Pressure Limited to Negative 100psf.

8500 Non Impact Horizontal Sliding Window Test # FTL 4456 - 3/16" Annealed Flange Frame (XO or OX) w/ HEAVY DUTY MEETING RAIL & STANDARD SILL					
Width (in)	Height (in)	DP(+) psf	DP(-) psf	Anchors	
				Head & Sill	Each Jamb
26.5	26	60.0	100.0	2	2
37	26	60.0	100.0	2	2
53.125	26	60.0	100.0	3	2
74	26	60.0	100.0	5	2
26.5	38.375	60.0	100.0	2	2
37	38.375	60.0	100.0	3	2
53.125	38.375	60.0	100.0	4	2
74	38.375	60.0	83.8	5	2
26.5	50.625	60.0	100.0	2	2
37	50.625	60.0	100.0	3	2
53.125	50.625	60.0	77.0	4	2
74	50.625	60.0	63.6	5	2
26.5	58	60.0	100.0	3	2
37	58	60.0	88.7	3	3
53.125	58	60.0	67.1	4	2
74	58	53.7	53.7	4	3
26.5	63	60.0	100.0	3	2
37	63	60.0	80.5	3	2
53.125	63	60.0	60.6	4	2
74	63	48.3	48.3	4	2
24	24	60.0	100.0	2	2
36	24	60.0	100.0	2	2
48	24	60.0	100.0	3	2
60	24	60.0	100.0	3	2
72	24	60.0	100.0	4	2
24	36	60.0	100.0	2	2
36	36	60.0	100.0	3	2
48	36	60.0	100.0	3	2
60	36	60.0	94.8	4	2
72	36	60.0	88.1	5	2
24	48	60.0	100.0	2	2
36	48	60.0	100.0	3	2
48	48	60.0	89.7	4	2
60	48	60.0	76.0	4	2
72	48	60.0	69.5	5	2
24	60	60.0	100.0	2	2
36	60	60	87.2	3	3
48	60	60	69.5	3	2
60	60	56.7	56.7	4	2
72	60	51.6	51.6	4	2

Pressure Limited to Negative 100psf.

8500 Non Impact Horizontal Sliding Window Test # FTL 4456 - 3/16" Annealed Flange Frame (XO or OX) w/ HEAVY DUTY MEETING RAIL & HI-RISE SILL					
Width (in)	Height (in)	DP(+) psf	DP(-) psf	Anchors	
				Head & Sill	Each Jamb
26.5	26	73.3	100.0	2	2
37	26	73.3	100.0	2	2
53.125	26	73.3	100.0	3	2
74	26	73.3	100.0	5	2
26.5	38.375	73.3	100.0	2	2
37	38.375	73.3	100.0	3	2
53.125	38.375	73.3	100.0	4	2
74	38.375	73.3	83.8	5	2
26.5	50.625	73.3	100.0	2	2
37	50.625	73.3	100.0	3	2
53.125	50.625	73.3	77.0	4	2
74	50.625	63.6	63.6	5	2
26.5	58	73.3	100.0	3	2
37	58	73.3	88.7	3	2
53.125	58	67.1	67.1	4	2
74	58	53.7	53.7	4	2
26.5	63	73.3	100.0	3	2
37	63	73.3	80.5	3	2
53.125	63	60.6	60.6	4	2
74	63	48.3	48.3	4	2
24	24	73.3	100.0	2	2
36	24	73.3	100.0	2	2
48	24	73.3	100.0	3	2
60	24	73.3	100.0	3	2
72	24	73.3	100.0	4	2
24	36	73.3	100.0	2	2
36	36	73.3	100.0	3	2
48	36	73.3	100.0	3	2
60	36	73.3	94.8	4	2
72	36	73.3	88.1	5	2
24	48	73.3	100.0	2	2
36	48	73.3	100.0	3	2
48	48	73.3	89.7	4	2
60	48	73.3	76.0	4	2
72	48	69.5	69.5	5	2
24	60	73.3	100.0	2	2
36	60	73.3	87.2	3	3
48	60	69.5	69.5	3	2
60	60	56.7	56.7	4	2
72	60	51.6	51.6	4	2

Pressure Limited to Negative 100psf.

8500 Non Impact Horizontal Sliding Window Test # FTL 4553 - 3/16" Annealed Flange Frame (XO or OX) w/ STANDARD MEETING RAIL & STANDARD SILL					
Width (in)	Height (in)	DP(+) psf	DP(-) psf	Anchors	
				Head & Sill	Each Jamb
26.5	26	60.0	100.0	2	2
37	26	60.0	100.0	2	2
53.125	26	60.0	100.0	3	2
74	26	60.0	100.0	5	2
26.5	38.375	60.0	100.0	2	2
37	38.375	60.0	100.0	3	2
53.125	38.375	60.0	83.8	4	2
74	38.375	60.0	76.0	5	2
26.5	50.625	60.0	95.8	2	2
37	50.625	60.0	73.0	3	2
53.125	50.625	56.3	56.3	3	2
74	50.625	47.0	47.0	4	2
24	24	60.0	100.0	2	2
36	24	60.0	100.0	2	2
48	24	60.0	100.0	3	2
60	24	60.0	100.0	3	2
72	24	60.0	100.0	4	2
24	36	60.0	100.0	2	2
36	36	60.0	100.0	3	2
48	36	60.0	97.0	3	2
60	36	60.0	88.7	4	2
72	36	60.0	86.2	5	2
24	48	60.0	100.0	2	2
36	48	60.0	79.6	3	2
48	48	60.0	64.7	3	2
60	48	56.4	56.4	3	2
72	48	51.7	51.7	4	2

Pressure Limited to Negative 100psf.

8500 Non Impact Horizontal Sliding Window Test # FTL 4553 - 3/16" Annealed Flange Frame (XO or OX) w/ STANDARD MEETING RAIL & HI-RISE SILL					
Width (in)	Height (in)	DP(+) psf	DP(-) psf	Anchors	
				Head & Sill	Each Jamb
26.5	26	73.3	100.0	2	2
37	26	73.3	100.0	2	2
53.125	26	73.3	100.0	3	2
74	26	73.3	100.0	5	2
26.5	38.375	73.3	100.0	2	2
37	38.375	73.3	100.0	3	2
53.125	38.375	73.3	83.8	4	2
74	38.375	73.3	76.0	5	2
26.5	50.625	73.3	95.8	2	2
37	50.625	73.0	73.0	3	2
53.125	50.625	56.3	56.3	3	2
74	50.625	47.0	47.0	4	2
24	24	73.3	100.0	2	2
36	24	73.3	100.0	2	2
48	24	73.3	100.0	3	2
60	24	73.3	100.0	3	2
72	24	73.3	100.0	4	2
24	36	73.3	100.0	2	2
36	36	73.3	100.0	3	2
48	36	73.3	97.0	3	2
60	36	73.3	88.7	4	2
72	36	73.3	86.2	5	2
24	48	73.3	100.0	2	

8500 Non Impact Horizontal Sliding Window (XO Or OX) Test # HET1-08-2158 thru 08-2160 - 1/8" Tempered Flange Frame w/ HEAVY DUTY MEETING RAIL & STANDARD SILL					
Width (in)	Height (in)	DP(+) psf	DP(-) psf	Anchors	
				Head & Sill	Each Jamb
26.5	26	60.0	100.0	2	2
37	26	60.0	100.0	2	2
53.125	26	60.0	100.0	3	2
74	26	60.0	100.0	5	2
26.5	38.375	60.0	100.0	2	2
37	38.375	60.0	100.0	3	2
53.125	38.375	60.0	100.0	4	2
74	38.375	60.0	100.0	6	2
26.5	50.625	60.0	100.0	2	2
37	50.625	60.0	100.0	3	2
53.125	50.625	60.0	93.0	4	3
74	50.625	60.0	77.6	5	3
26.5	58	60.0	100.0	3	2
37	58	60.0	100.0	4	3
53.125	58	60.0	77.6	4	3
74	58	60.0	63.1	5	3
26.5	63	60.0	100.0	3	2
37	63	60.0	92.7	4	3
53.125	63	60.0	69.8	4	3
74	63	56.0	56.0	5	3
24	24	60.0	100.0	2	2
36	24	60.0	100.0	2	2
48	24	60.0	100.0	3	2
60	24	60.0	100.0	3	2
72	24	60.0	100.0	4	2
24	36	60.0	100.0	2	2
36	36	60.0	100.0	3	2
48	36	60.0	100.0	3	2
60	36	60.0	100.0	4	2
72	36	60.0	100.0	5	2
24	48	60.0	100.0	2	2
36	48	60.0	100.0	3	2
48	48	60.0	100.0	4	3
60	48	60.0	93.1	5	3
72	48	60.0	85.4	6	3
24	60	60.0	100.0	2	2
36	60	60.0	100.0	4	3
48	60	60.0	80.0	4	3
60	60	60.0	68.3	4	3
72	60	60.0	61.0	5	3

Pressure Limited to Negative 100psf.

8500 Non Impact Horizontal Sliding Window (XO Or OX) Test # HET1-08-2158 thru 08-2160 - 1/8" Tempered Flange Frame w/ HEAVY DUTY MEETING RAIL & HI-RISE SILL					
Width (in)	Height (in)	DP(+) psf	DP(-) psf	Anchors	
				Head & Sill	Each Jamb
26.5	26	73.3	100.0	2	2
37	26	73.3	100.0	2	2
53.125	26	73.3	100.0	3	2
74	26	73.3	100.0	5	2
26.5	38.375	73.3	100.0	2	2
37	38.375	73.3	100.0	3	2
53.125	38.375	73.3	100.0	4	2
74	38.375	73.3	100.0	6	2
26.5	50.625	73.3	100.0	2	2
37	50.625	73.3	100.0	3	2
53.125	50.625	73.3	93.0	4	3
74	50.625	73.3	77.6	5	3
26.5	58	73.3	100.0	3	2
37	58	73.3	100.0	4	3
53.125	58	73.3	77.6	4	3
74	58	63.1	63.1	5	3
26.5	63	73.3	100.0	3	2
37	63	73.3	92.7	4	3
53.125	63	69.8	69.8	4	3
74	63	56.0	56.0	5	3
24	24	73.3	100.0	2	2
36	24	73.3	100.0	2	2
48	24	73.3	100.0	3	2
60	24	73.3	100.0	3	2
72	24	73.3	100.0	4	2
24	36	73.3	100.0	2	2
36	36	73.3	100.0	3	2
48	36	73.3	100.0	3	2
60	36	73.3	100.0	4	2
72	36	73.3	100.0	5	2
24	48	73.3	100.0	2	2
36	48	73.3	100.0	3	2
48	48	73.3	100.0	4	3
60	48	73.3	93.1	5	3
72	48	73.3	85.4	6	3
24	60	73.3	100.0	2	2
36	60	73.3	100.0	4	3
48	60	73.3	80.0	4	3
60	60	68.3	68.3	4	3
72	60	61.0	61.0	5	3

Pressure Limited to Negative 100psf.

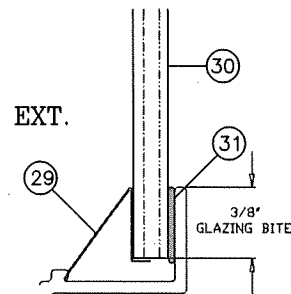

MONOLITHIC GLASS - SINGLE GLAZE  
ANNEALED OR TEMPERED(\*)  
1/8", 3/16" OR 1/4" THICK  
(SEE DESIGN PRESSURE TABLES)  
**GLAZING DETAIL & DESCRIPTION**

Note:  
1. WINDOW WIDTHS & HEIGHTS  
ARE THE OVERALL EXTERIOR  
FRAME DIMENSIONS.

\* Tempered glass marked in  
compliance with CPSC 16 CFR  
Part 1201" or "ANSI  
Z97.1-2015.

**PRODUCT REVISED**  
As complying with the Florida  
Building Code  
NOA-No. **25-1219.01**  
Expiration Date: **01/26/2031**  
By: *Manuel Perez*  
Miami-Dade Product Control

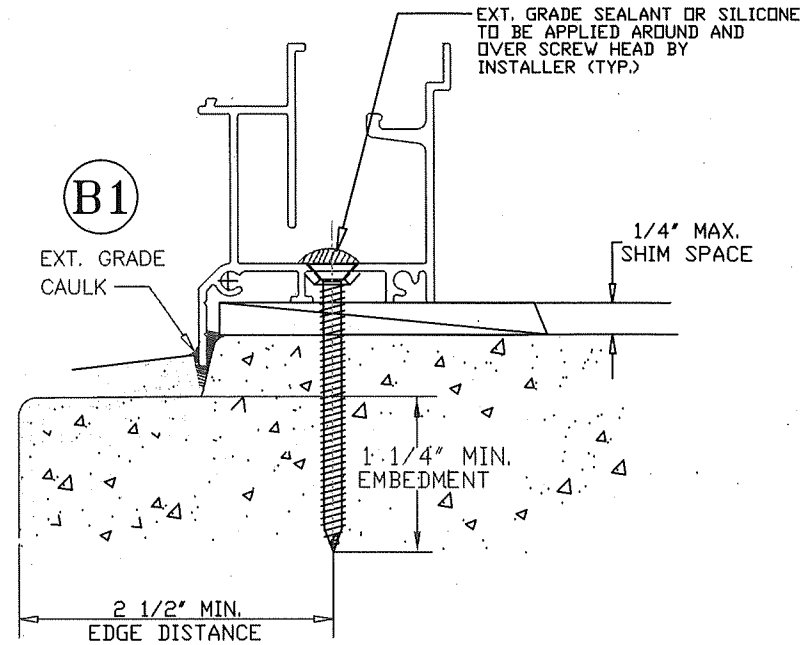

**OPTIONAL SILL INSTALLATION DETAIL**

**ANCHORS NOTE:**  
ANCHORS TO BE #12 SMS OR WD. SCREWS INTO WOOD, OR  
1/4" TAPCONS OR APPROVED CONC. FASTENERS INTO CONC.,  
WITH A MINIMUM OF 1 1/4" PENETRATION INTO WOOD OR  
CONC. (REFER TO LOAD TABLES FOR QUANTITIES REQUIRED)

\* WHEN THE GAP BETWEEN THE WINDOW FRAME AND THE BUCK  
OR MASONRY IS LESS THAN 1/8", SHIMS ARE NOT REQUIRED.

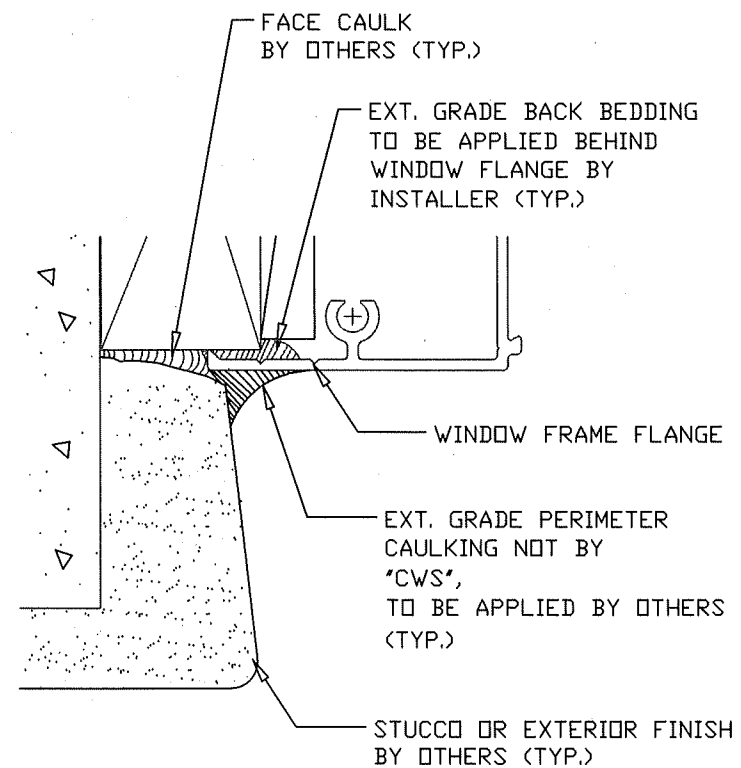

**WINDOW INSTALLATION DETAIL**

**CWS**  
1900 SW 44TH AVE.  
OCALA, FLORIDA 34474  
WWW.CWS.CC

**CWS 320 ALUMINUM  
FLANGE FRAME NON-IMPACT  
HORIZONTAL ROLLING WINDOW**

NO.	DESCRIPTION	BY	DATE
B	Renews NOA # 22-0612.03	N.E.	12/13/25
A	Revises NOA # 23-1017.08	N.E.	05/15/25

**THOMAS J. SOTOS  
PROFESSIONAL ENGINEER  
FL LIC. # 55225**

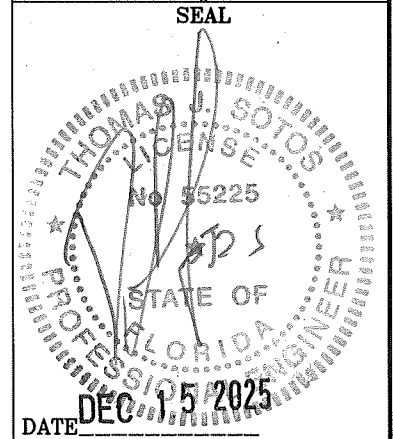

SHEET DESCRIPTION:  
**GLASS LOAD CHARTS,  
GLAZING DETAIL, OPTIONAL  
INSTALLATION DETAIL**

DRAWN BY: NELSON ERAZO	DATE: 11/17/2023
REV. BY: N.E.	DATE: 05/15/2025
DWG #: CWS-1256	REV #: B
SCALE: AS NOTED	SHEET 6 OF 9

8500 Non Impact Horizontal Sliding Window Test # FTL 4429 - 1/4" Annealed Flange Frame (XOX) w/ HEAVY DUTY MEETING RAIL & STANDARD SILL						
Width (in)	Height (in)	DP(+) psf	DP(-) psf	Anchors		
				Head & Sill	Each Jamb	
53.125	26	60.0	100.0	3	2	
74	26	60.0	100.0	5	2	
106.375	26	60.0	100.0	7	2	
111	26	60.0	100.0	7	2	
53.125	38.375	60.0	100.0	4	2	
74	38.375	60.0	100.0	6	2	
106.375	38.375	60.0	76.9	7	2	
111	38.375	60.0	73.1	7	2	
53.125	50.625	60.0	100.0	6	2	
74	50.625	60.0	81.9	6	2	
106.375	50.625	60.0	65.0	7	2	
111	50.625	60.0	61.9	7	2	
53.125	58	60.0	90.8	6	2	
74	58	60.0	70.3	6	2	
106.375	58	57.2	57.2	7	2	
111	58	55.5	55.5	8	2	
53.125	63	60.0	82.1	6	2	
74	63	60.0	62.5	6	2	
106.375	63	52.1	52.1	7	2	
111	63	51.1	51.1	8	2	
72	24	60.0	100.0	4	2	
84	24	60.0	100.0	5	2	
96	24	60.0	100.0	6	2	
108	24	60.0	100.0	6	2	
120	24	60.0	100.0	7	2	
72	36	60.0	100.0	6	2	
84	36	60.0	94.4	6	2	
96	36	60.0	87.0	7	2	
108	36	60.0	78.6	7	2	
120	36	60.0	68.5	7	2	
72	48	60.0	87.2	6	2	
84	48	60.0	80.3	7	2	
96	48	60.0	74.3	7	2	
108	48	60.0	66.4	7	2	
120	48	59.3	59.3	8	2	
72	60	60.0	69.2	6	2	
84	60	60	61.5	6	2	
96	60	58.6	58.6	7	2	
108	60	54.8	54.8	8	2	
120	60	51	51	8	2	

Pressure Limited to Negative 100psf.

8500 Non Impact Horizontal Sliding Window Test # FTL 4429 - 1/4" Annealed Flange Frame (XOX) w/ HEAVY DUTY MEETING RAIL & HI-RISE SILL						
Width (in)	Height (in)	DP(+) psf	DP(-) psf	Anchors		
				Head & Sill	Each Jamb	
53.125	26	73.3	100.0	3	2	
74	26	73.3	100.0	5	2	
106.375	26	73.3	100.0	7	2	
111	26	73.3	100.0	7	2	
53.125	38.375	73.3	100.0	4	2	
74	38.375	73.3	100.0	6	2	
106.375	38.375	73.3	76.9	7	2	
111	38.375	73.1	73.1	7	2	
53.125	50.625	73.3	100.0	6	2	
74	50.625	73.3	81.9	6	2	
106.375	50.625	65.0	65.0	7	2	
111	50.625	61.9	61.9	7	2	
53.125	58	73.3	90.8	6	2	
74	58	70.3	70.3	6	2	
106.375	58	57.2	57.2	7	2	
111	58	55.5	55.5	8	2	
53.125	63	73.3	82.1	6	2	
74	63	62.5	62.5	6	2	
106.375	63	52.1	52.1	7	2	
111	63	51.1	51.1	8	2	
72	24	73.3	100.0	4	2	
84	24	73.3	100.0	5	2	
96	24	73.3	100.0	6	2	
108	24	73.3	100.0	6	2	
120	24	73.3	100.0	7	2	
72	36	73.3	100.0	6	2	
84	36	73.3	94.4	6	2	
96	36	73.3	87.0	7	2	
108	36	73.3	78.6	7	2	
120	36	68.5	68.5	7	2	
72	48	73.3	87.2	6	2	
84	48	73.3	80.3	7	2	
96	48	73.3	74.3	7	2	
108	48	66.4	66.4	7	2	
120	48	59.3	59.3	8	2	
72	60	69.2	69.2	6	2	
84	60	61.5	61.5	6	2	
96	60	58.6	58.6	7	2	
108	60	54.8	54.8	8	2	
120	60	51	51	8	2	

Pressure Limited to Negative 100psf.

8500 Non Impact Horizontal Sliding Window Test # FTL 4457 - 3/16" Annealed Flange Frame (XOX) w/ HEAVY DUTY MEETING RAIL & STANDARD SILL						
Width (in)	Height (in)	DP(+) psf	DP(-) psf	Anchors		
				Head & Sill	Each Jamb	
53.125	26	60.0	100.0	3	2	
74	26	60.0	100.0	5	2	
106.375	26	60.0	81.6	5	2	
111	26	60.0	79.0	5	2	
53.125	38.375	60.0	100.0	4	2	
74	38.375	60.0	86.0	5	2	
106.375	38.375	60.0	61.6	6	2	
111	38.375	58.7	58.7	6	2	
53.125	50.625	60.0	86.5	5	2	
74	50.625	60.0	65.7	5	2	
106.375	50.625	52.3	52.3	6	2	
111	50.625	50.3	50.3	6	2	
53.125	58	60.0	79.4	5	2	
74	58	54.6	54.6	5	2	
106.375	58	46.5	46.5	6	2	
111	58	44.9	44.9	6	2	
53.125	63	60.0	72.0	5	2	
74	63	49.2	49.2	5	2	
106.375	63	42.9	42.9	6	2	
111	63	41.3	41.3	6	2	
72	24	60.0	100.0	4	2	
84	24	60.0	100.0	5	2	
96	24	60.0	95.3	5	2	
108	24	60.0	90.5	6	2	
120	24	60.0	85.3	6	2	
72	36	60.0	91.2	5	2	
84	36	60.0	82.0	5	2	
96	36	60.0	74.2	6	2	
108	36	60.0	62.0	6	2	
120	36	53.3	53.3	6	2	
72	48	60.0	71.3	5	2	
84	48	60.0	65.8	6	2	
96	48	60.0	60.0	6	2	
108	48	53.7	53.7	6	2	
120	48	48.7	48.7	6	2	
72	60	52.6	52.6	5	2	
84	60	50.7	50.7	6	2	
96	60	48.3	48.3	6	2	
108	60	44.5	44.5	6	2	
120	60	40.8	40.8	7	2	

Pressure Limited to Negative 100psf.

8500 Non Impact Horizontal Sliding Window Test # FTL 4457 - 3/16" Annealed Flange Frame (XOX) w/ HEAVY DUTY MEETING RAIL & HI-RISE SILL						
Width (in)	Height (in)	DP(+) psf	DP(-) psf	Anchors		
				Head & Sill	Each Jamb	
53.125	26	73.3	100.0	3	2	
74	26	73.3	100.0	5	2	
106.375	26	73.3	81.6	5	2	
111	26	73.3	79.0	5	2	
53.125	38.375	73.3	100.0	4	2	
74	38.375	73.3	86.0	5	2	
106.375	38.375	61.6	61.6	6	2	
111	38.375	58.7	58.7	6	2	
53.125	50.625	73.3	86.5	5	2	
74	50.625	65.7	65.7	5	2	
106.375	50.625	52.3	52.3	6	2	
111	50.625	50.3	50.3	6	2	
53.125	58	73.3	79.4	5	2	
74	58	54.6	54.6	5	2	
106.375	58	46.5	46.5	6	2	
111	58	44.9	44.9	6	2	
53.125	63	72.0	72.0	5	2	
74	63	49.2	49.2	5	2	
106.375	63	42.9	42.9	6	2	
111	63	41.3	41.3	6	2	
72	24	73.3	100.0	4	2	
84	24	73.3	100.0	5	2	
96	24	73.3	95.3	5	2	
108	24	73.3	90.5	6	2	
120	24	73.3	85.3	6	2	
72	36	73.3	91.2	5	2	
84	36	73.3	82.0	5	2	
96	36	73.3	74.2	6	2	
108	36	62.0	62.0	6	2	
120	36	53.3	53.3	6	2	
72	48	71.3	71.3	5	2	
84	48	65.8	65.8	6	2	
96	48	60.0	60.0	6	2	
108	48	53.7	53.7	6	2	
120	48	48.7	48.7	6	2	
72	60	52.6	52.6	5	2	
84	60	50.7	50.7	6	2	
96	60	48.3	48.3	6	2	
108	60	44.5	44.5	6	2	
120	60	40.8	40.8	7	2	

Pressure Limited to Negative 100psf.

8500 Non Impact Horizontal Sliding Window Test # FTL 4594 - 3/16" Annealed Flange Frame (XOX) w/ STANDARD MEETING RAIL & STANDARD SILL						
Width (in)	Height (in)	DP(+) psf	DP(-) psf	Anchors		
				Head & Sill	Each Jamb	
53.125	26	60.0	100.0	3	2	
74	26	60.0	100.0	5	2	
106.375	26	60.0	81.6	5	2	
111	26	60.0	79.0	5	2	
53.125	38.375	60.0	93.2	4	2	
74	38.375	60.0	79.6	5	2	
106.375	38.375	60.0	61.6	6	2	
111	38.375	58.7	58.7	6	2	
53.125	50.625	60.0	64.3	4	2	
74	50.625	51.9	51.9	4	2	
106.375	50.625	44.6	44.6	5	2	
111	50.625	44.1	44.1	5	2	
72	24	60.0	100.0	4	2	
84	24	60.0	100.0	5	2	
96	24	60.0	95.3	5	2	
108	24	60.0	90.5	6	2	
120	24	60.0	85.3	6	2	
72	36	60.0	89.4	5	2	
84	36	60.0	82.0	5	2	
96	36	60.0	74.2	6	2	
108	36	60.0	62.0	6	2	
120	36	53.3	53.3	6	2	
72	48	56.9	56.9	4	2	
84	48	52.8	52.8	5	2	
96	48	50.3	50.3	5	2	
108	48	48.7	48.7	6	2	
120	48	47.3	47.3	6	2	

Pressure Limited to Negative 100psf.

8500 Non Impact Horizontal Sliding Window Test # FTL 4594 - 3/16" Annealed Flange Frame (XOX) w/ STANDARD MEETING RAIL & HI-RISE SILL						
Width (in)	Height (in)	DP(+) psf	DP(-) psf	Anchors		
				Head & Sill	Each Jamb	
53.125	26	73.3	100.0	3	2	
74	26	73.3	100.0	5	2	
106.375	26	73.3	81.6	5	2	
111	26	73.3	79.0	5	2	
53.125	38.375	73.3	93.2	4	2	
74	38.375	73.3	79.6	5	2	
106.375	38.375	61.6	61.6	6	2	
111	38.375	58.7	58.7	6	2	
53.125	50.625	64.3	64.3	4	2	
74	50.625	51.9	51.9	4	2	
106.375	50.625	44.6	44.6	5	2	
111	50.625	44.1	44.1	5	2	
72	24	73.3	100.0	4	2	
84	24	73.3	100.0	5	2	
96	24	73.3	95.3	5	2	
108	24	73.3	90.5	6	2	
120	24	73.3	85.3	6	2	
72	36	73.3	89.4	5	2	
84	36	73.3	82.0	5	2	
96	36	73.3	74.2	6	2	
108	36	62.0	62.0	6	2	
120	36	53.3	53.3	6	2	
72	48	56.9	56.9	4		



FRAME HEAD  
L-7503

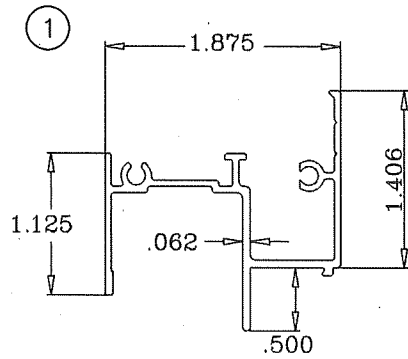

VENT INTERLOCK RAIL (Heavy Duty)  
L-7506

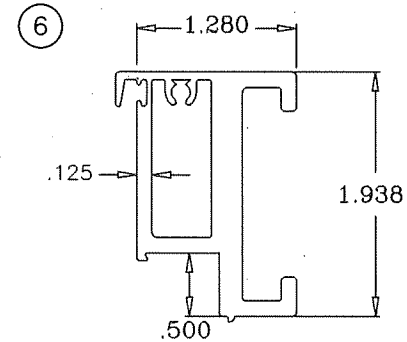

GLAZING BEAD  
L-7516

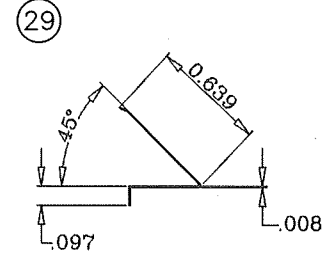

FIXED MEETING RAIL  
L-7504

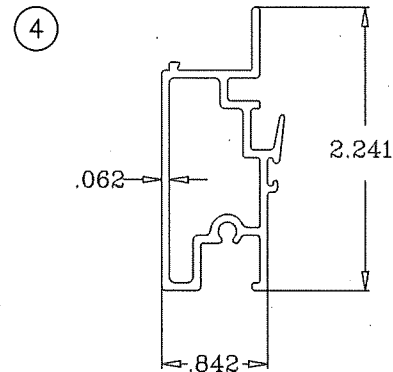

VENT INTERLOCK RAIL (Standard Duty)  
L-7505

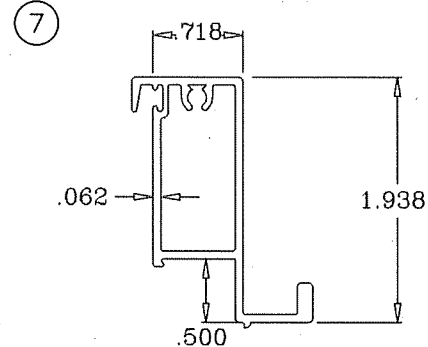

FRAME SILL RISER ADAPTER  
L-8503

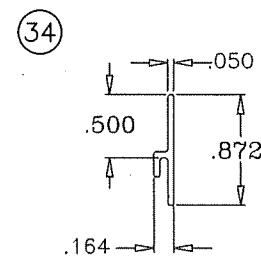

VENT JAMB RAIL  
L-7507

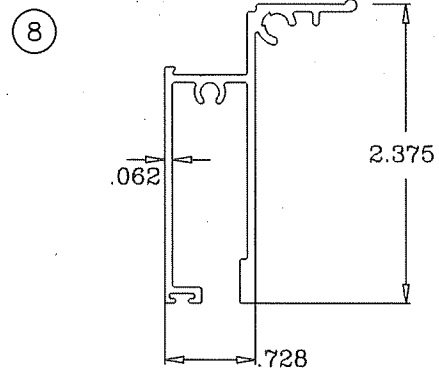

FRAME SILL  
L-8501

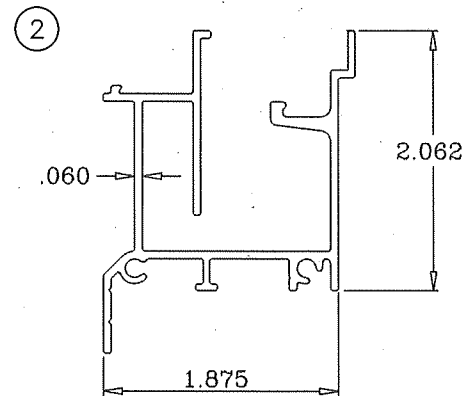

FRAME SILL ANCHOR CLIP  
L-8730

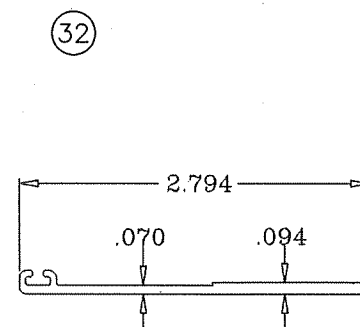

FRAME JAMB  
L-8502

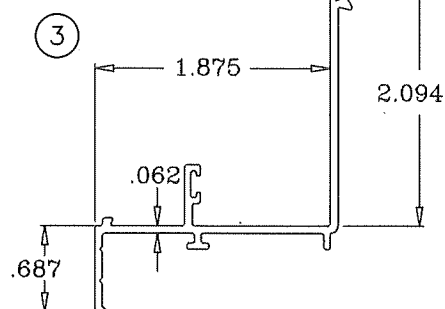

VENT TOP / BOTTOM RAIL  
L-7508

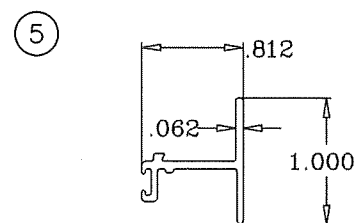

**PRODUCT REVISED**  
As complying with the Florida  
Building Code  
NOA-No. **25-1219.01**  
Expiration Date: **01/26/2031**  
By: *Manuel Perez*  
Miami-Dade Product Control

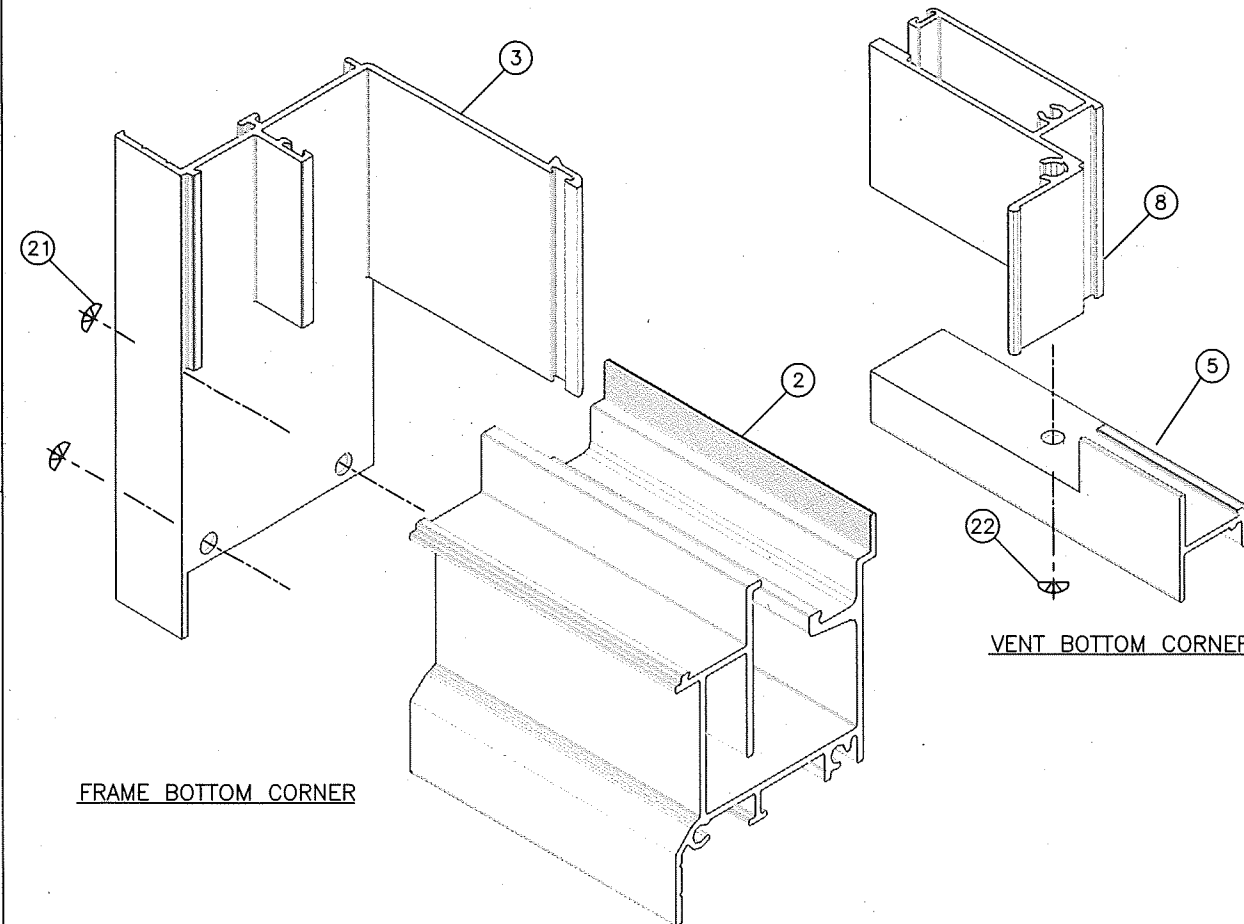

FRAME & SASH CORNER DETAILS

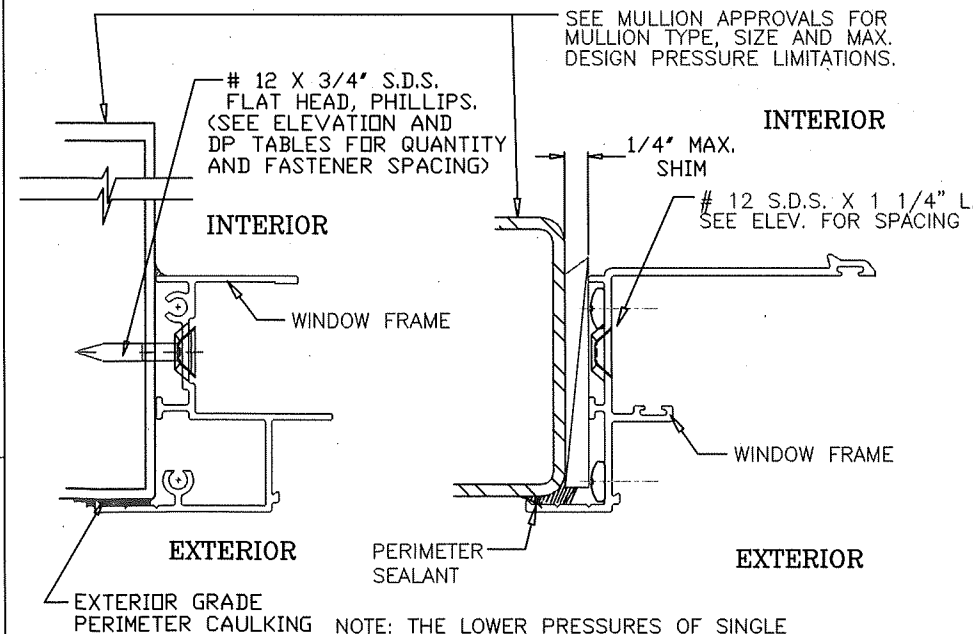

NOTE: THE LOWER PRESSURES OF SINGLE HUNG WINDOW OR MULL SHALL GOVERN

- ALL STEEL IN CONTACT WITH ALUM. TO BE PAINTED OR PLATED.
- METAL STRUCTURES: (STEEL OR ALUM. 1/8" MIN. THICK)
  - A) STEEL : Fy = 36 KSI MIN.
  - B) ALUMINUM : 6063-T5 MIN.

**E**

MULLION & METAL STRUCTURE ATTACHMENT DETAIL



1900 SW 44TH AVE.  
OCALA, FLORIDA 34474  
WWW.CWS.CC

**CWS 320 ALUMINUM  
FLANGE FRAME NON-IMPACT  
HORIZONTAL ROLLING WINDOW**

NO.	DESCRIPTION:	BY:	DATE:
B	Revises NDA # 22-061203	NE.	12/13/25
A	Revises NDA # 23-101708	NE.	05/15/25

**THOMAS J. SOTOS  
PROFESSIONAL ENGINEER  
FL LIC. # 55225**

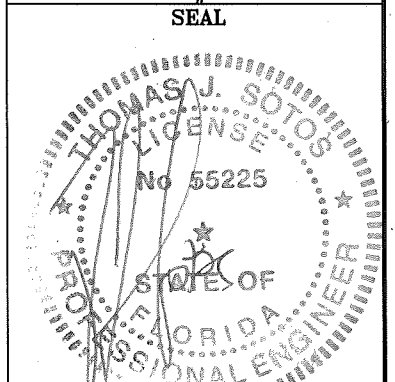

DATE **DEC 15 2025**

SHEET DESCRIPTION:  
**EXTRUSION DETAILS,  
CORNER ASSEMBLY  
DETAILS & METAL  
ATTACHMENT DETAILS**

DRAWN BY:	DATE:
NELSON ERAZO	11/17/2023
REV. BY:	DATE:
N.E.	05/15/2025
DWG #:	REV #:
CWS-1256	B
SCALE:	SHEET
AS NOTED	9 OF 9