



DEPARTMENT OF REGULATORY AND ECONOMIC RESOURCES (RER)
BOARD AND CODE ADMINISTRATION DIVISION

NOTICE OF ACCEPTANCE (NOA)

MIAMI-DADE COUNTY
PRODUCT CONTROL SECTION

11805 SW 26 Street, Room 208
Miami, Florida 33175-2474
T (786) 315-2590 F (786) 315-2599

www.miamidade.gov/economy

Clopay Corporation
8585 Duke Boulevard
Mason, OH 45040

SCOPE:

This NOA is being issued under the applicable rules and regulations governing the use of construction materials. The documentation submitted has been reviewed and accepted by Miami-Dade County RER-Product Control Section to be used in Miami Dade County and other areas where allowed by the Authority Having Jurisdiction (AHJ).

This NOA shall not be valid after the expiration date stated below. The Miami-Dade County Product Control Section (In Miami Dade County) and/or the AHJ (in areas other than Miami Dade County) reserve the right to have this product or material tested for quality assurance purposes. If this product or material fails to perform in the accepted manner, the manufacturer will incur the expense of such testing and the AHJ may immediately revoke, modify, or suspend the use of such product or material within their jurisdiction. RER reserves the right to revoke this acceptance, if it is determined by Miami-Dade County Product Control Section that this product or material fails to meet the requirements of the applicable building code.

This product is approved as described herein, and has been designed to comply with the Florida Building Code, including the High Velocity Hurricane Zone.

DESCRIPTION: Commercial 1-3/4” Intellicore Insulated W6 DP36T Steel Sectional Garage Door up to 18’-2” Wide w/ Optional Impact Resistant Lites

APPROVAL DOCUMENT: Drawing No. **104826**, titled “1-3/4” Intellicore Doors up to 18’2”W”, sheets 1 through 3 of 3, dated 07/28/2014, with revision **9** dated 10/09/2025, prepared by Clopay Corporation, signed and sealed by James D. Wheeler, P.E. on 05/21/2026, bearing the Miami-Dade County Product Control revision stamp with the Notice of Acceptance number and expiration date by the Miami-Dade County Product Control Section.

MISSILE IMPACT RATING: Large and Small Missile Impact Resistant

LABELING: A permanent label with the manufacturer’s name or logo, manufacturing address, model number, the positive and negative design pressure rating, indicate impact rated if applicable, installation instruction drawing reference number, approval number (NOA), the applicable test standards, and the statement reading ‘Miami-Dade County Product Control Approved’ is to be located on the door’s side track, bottom angle, or inner surface of a panel.

RENEWAL of this NOA shall be considered after a renewal application has been filed and there has been no change in the applicable building code negatively affecting the performance of this product.

TERMINATION of this NOA will occur after the expiration date or if there has been a revision or change in the materials, use, and/or manufacture of the product or process. Misuse of this NOA as an endorsement of any product, for sales, advertising or any other purposes shall automatically terminate this NOA. Failure to comply with any section of this NOA shall be cause for termination and removal of NOA.

ADVERTISEMENT: The NOA number preceded by the words Miami-Dade County, Florida, and followed by the expiration date may be displayed in advertising literature. If any portion of the NOA is displayed, then it shall be done in its entirety.

INSPECTION: A copy of this entire NOA shall be provided to the user by the manufacturer or its distributors and shall be available for inspection at the job site at the request of the Building Official.

This NOA **revises NOA # 24-1125.04** and consists of this page 1 and evidence pages E-1, E-2, E-3, E-4 and E-5, as well as approval document mentioned above.

The submitted documentation was reviewed by **Carlos M. Utrera, P.E.**



06/17/2026

NOA No 26-0313.15
Expiration Date: **January 15, 2030**
Approval Date: **June 25, 2026**
Page 1

NOTICE OF ACCEPTANCE: EVIDENCE SUBMITTED

1. Evidence submitted under previous NOA's

A. DRAWINGS

1. Drawing No. **104826**, titled "1-3/4" Intellicore Doors up to 18'2"W", sheets 1 through 3 of 3, dated 07/28/2014, with revision 4 dated 2/2015, prepared by Clopay Building Products Company, signed and sealed by Mark Westerfield, P.E.
"Submitted under NOA # 15-0225.29"
2. Drawing No. **104826**, titled "1-3/4" Intellicore Doors up to 18'2"W", sheets 1 through 3 of 3, dated 07/28/2014, with revision 5 dated 7/2017, prepared by Clopay Building Products Company, signed and sealed by Mark Westerfield, P.E.
"Submitted under NOA # 17-0809.17"

B. TESTS

1. Test reports on 1) Uniform Static Air Pressure Test, Loading per FBC TAS 202-94
2) Large Missile Impact Test per FBC, TAS 201-94
3) Cyclic Wind Pressure Loading per FBC, TAS 203-94
4) Forced Entry Test, per FBC, TAS 202-94
5) Tensile Test per ASTM E8
along with marked-up drawings and installation diagram of 18'2"x 8', 27ga steel garage door Model 3717W6 with Lexan MR10 windows, prepared by American Test Lab, Inc., Test Report No. **ATLNC 0916.01-13**, dated 02/20/2014, Addendum dated 05/21/2014 and Addendum 2 dated 06/11/2014 to Test Report No. **ATLNC 0916.01-13**, signed and sealed by David W. Johnson, P.E. *"Submitted under NOA # 14-0805.06"*
2. Test reports on 1) Uniform Static Air Pressure Test, Loading per FBC TAS 202-94
2) Large Missile Impact Test per FBC, TAS 201-94
3) Cyclic Wind Pressure Loading per FBC, TAS 203-94
4) Forced Entry Test, per FBC, TAS 202-94
5) Tensile Test per ASTM E8
Along with marked-up drawings and installation diagram of 16'2"x 8', 27ga steel garage door Model GD2LPW8 with MAK SL and/or MAK 15 windows, prepared by American Test Lab, Inc., Test Report No. **ATLNC 1105-01-13**, dated 01/14/2014, signed and sealed by David W. Johnson, P.E. *"Submitted under NOA # 14-0805.06"*
3. Test report on Salt Spray per ASTM B117 of painted G40 galvanized coated panels, prepared by Stork Materials Technology, Test Report No. **30160-04-63365**, dated 01/26/2005, signed by John D. Lee, P.E. *"Submitted under NOA # 14-0805.06"*



Carlos M. Utrera, P.E.
Product Control Examiner
NOA No 26-0313.15
Expiration Date: January 15, 2030
Approval Date: June 25, 2026

NOTICE OF ACCEPTANCE: EVIDENCE SUBMITTED

C. CALCULATIONS

1. Jamb anchor calculations prepared by Clopay Building Products Company, dated 07/22/2014, signed and sealed by Mark Westerfield, P.E. *“Submitted under NOA # 14-0805.06”*

D. QUALITY ASSURANCE

1. Miami-Dade Department of Regulatory and Economic Resources (RER).

E. MATERIAL CERTIFICATIONS

1. NOA No. **15-0915.08** issued to SABIC Innovative Plastics, US LLC for their Lexan Polycarbonate Sheet Products, approved on 12/10/2015, expiring on 07/17/2018.
2. Notice of Acceptance No. **17-0410.01** issued to Covestro LLC for their Makrolon Polycarbonate Sheets, approved on 06/08/2017, expiring on 08/27/2022.
3. Test report on Surface Burning Characteristics, per ASTM E84 of the polyurethane foam insulation, prepared by QAI Laboratories, Test Report No. **RJ2814-3**, dated 10/14/2013, signed by Greg Banasky.

E. STATEMENTS *“Submitted under NOA # 15-0225.29”*

1. Statement letter of code conformance with the 2010 and the 5th edition (2014) FBC issued by Clopay Building Products Company, dated 02/18/2015, signed and sealed by Mark Westerfield, P.E.
“Submitted under NOA # 14-0805.06”
2. Statement letters of code conformance to 2010 FBC and no financial interest, both issued by Clopay Building Products Company, dated 07/29/2014, signed and sealed by Mark Westerfield, P.E.
“Submitted under NOA # 17-0809.17”
3. Statement letter of code conformance to 2010, 5th Edition (2014) and 6th Edition (2017) FBC and no financial interest, issued by Clopay Building Products Company, dated 08/02/2017, signed and sealed by Mark Westerfield, P.E.



Carlos M. Utrera, P.E.
Product Control Examiner
NOA No 26-0313.15
Expiration Date: January 15, 2030
Approval Date: June 25, 2026

NOTICE OF ACCEPTANCE: EVIDENCE SUBMITTED

2. Evidence submitted under NOA # 20-0922.44

A. DRAWINGS

1. Drawing No. **104826**, titled "1-3/4" Intellicore Doors up to 18'2"W", sheets 1 through 3 of 3, dated 07/28/2014, with revision 6 dated 08/28/2020, prepared by Clopay Building Products Company, signed and sealed by Mark Westerfield, P.E.

B. TESTS

1. None.

C. CALCULATIONS

1. None.

D. QUALITY ASSURANCE

1. Miami-Dade Department of Regulatory and Economic Resources (RER).

E. MATERIAL CERTIFICATIONS

1. None.

F. STATEMENTS

1. Statement letter of code conformance to the 7th Edition (2020) FBC and Statement letter of no financial interest, issued by Clopay Building Products Company, dated 09/15/2020, signed and sealed by Mark Westerfield, P.E.

3. Evidence submitted under NOA # 23-0928.43

A. DRAWINGS

1. Drawing No. **104826**, titled "1-3/4" Intellicore Doors up to 18'2"W", sheets 1 through 3 of 3, dated 07/28/2014, with revision 7 dated 09/06/2023, prepared by Clopay Building Products Company, signed and sealed by Mark Westerfield, P.E. on 09/14/2023.

B. TESTS

1. None.

C. CALCULATIONS

1. None.

D. QUALITY ASSURANCE

1. Miami-Dade Department of Regulatory and Economic Resources (RER).

E. MATERIAL CERTIFICATIONS

1. None.

F. STATEMENTS

1. Statement letter of code conformance to the 7th Edition (2020) and 8th Edition (2023) of the FBC and statement letter of no financial interest, issued by Clopay Building Products Company, dated 09/15/2023, signed and sealed by Mark Westerfield, P.E.



Carlos M. Utrera, P.E.
Product Control Examiner
NOA No 26-0313.15
Expiration Date: January 15, 2030
Approval Date: June 25, 2026

NOTICE OF ACCEPTANCE: EVIDENCE SUBMITTED

4. Evidence submitted under NOA # 24-1125.04

A. DRAWINGS

1. Drawing No. **104826**, titled “1-3/4” Intellicore Doors up to 18’2” “W”, sheets 1 through 3 of 3, dated 07/28/2014, with revision 8 dated 11/2024, prepared by Clopay Corporation, signed and sealed by Mark Westerfield, P.E.

B. TESTS

1. Test reports on 1) Uniform Static Air Pressure Test, Loading per FBC TAS 202-94
2) Large Missile Impact Test per FBC, TAS 201-94
3) Cyclic Wind Pressure Loading per FBC, TAS 203-94
4) Forced Entry Test, per FBC, TAS 202-94
5) Tensile Test per ASTM E8

along with marked-up drawings and installation diagram of 18’2”x 8’, 27ga steel garage door, Model 3717W6 with windows, prepared by American Test Lab, Inc., Test Report No. **ATLNC 1021-01-24**, dated 11/11/2024, signed and sealed by David W. Johnson, P.E.

C. CALCULATIONS

1. Jamb anchor calculations, prepared by Clopay Corporation, dated 11/10/2024, signed and sealed by Mark Westerfield, P.E.

D. QUALITY ASSURANCE

1. Miami-Dade Department of Regulatory and Economic Resources (RER).

E. MATERIAL CERTIFICATIONS

1. Notice of Acceptance No. **24-0117.13** issued to SABIC Innovative Plastics, US LLC for its Lexan Polycarbonate Sheet Products, approved on 02/22/2024, expiring on 04/01/2026.
2. Notice of Acceptance No. **24-0205.09** issued to Plaskolite, LLC for its TUFFAK Polycarbonate Sheets, approved on 05/09/2024, expiring on 08/27/2027.
3. Test report on Surface Burning Characteristics, per ASTM E84-21a of the Elastopor 53021R Polyurethane Foam, Test Report No. **BASF (639)030623-71BR1**, prepared by ICC-NTA, LLC, dated 03/27/2023, signed by Glenn Schwabe.
4. Test report on Ignition Temperature, per ASTM D1929-2023 of the IC1 EP50279, Test Report No. **105638072MID-001A**, prepared by Intertek, dated 11/16/2023, signed by Sandy Osborne.

F. STATEMENTS

1. Statement letters of code conformance with the 8th Edition (2023) of the FBC, and of no financial interest, both issued by Clopay Corporation, dated 11/10/2024, signed and sealed by Mark Westerfield, P.E.



Carlos M. Utrera, P.E.
Product Control Examiner
NOA No 26-0313.15
Expiration Date: January 15, 2030
Approval Date: June 25, 2026

NOTICE OF ACCEPTANCE: EVIDENCE SUBMITTED

5. New evidence submitted

A. DRAWINGS

1. Drawing No. **104826**, titled "1-3/4" Intellicore Doors up to 18'2" "W", sheets 1 through 3 of 3, dated 07/28/2014, with revision **9** dated 10/09/2025, prepared by Clopay Corporation, signed and sealed by James D. Wheeler, P.E. on 05/21/2026.

B. TESTS

1. Test reports on 1) Uniform Static Air Pressure Test, Loading per FBC TAS 202-94
2) Large Missile Impact Test per FBC, TAS 201-94
3) Cyclic Wind Pressure Loading per FBC, TAS 203-94
4) Forced Entry Test, per FBC, TAS 202-94
5) Tensile Test per ASTM E8

Along with marked-up drawings and installation diagram of 9'x 8', 27ga steel garage door Model GD2LP W8 with 1/4" thick Polycarbonate windows, prepared by American Test Lab, Inc., Test Report No. **ATLNC 0902.01-25**, dated 10/15/2025, signed and sealed by David W. Johnson, P.E. on 10/20/2025.

C. CALCULATIONS

1. None.

D. QUALITY ASSURANCE

1. Miami-Dade Department of Regulatory and Economic Resources (RER).

E. MATERIAL CERTIFICATIONS

1. None.



Carlos M. Utrera, P.E.
Product Control Examiner
NOA No 26-0313.15
Expiration Date: January 15, 2030
Approval Date: June 25, 2026

The following pages in this document were submitted by the manufacturer (third party) to represent the product being approved and establish the limits of use. The pages may include technical drawings, schematics and installation details.

CLOPAY	/	IDEAL	/	HOLMES						
3717	/	C7X17	/	--	/	27GA	1.75"	THICK	MINOR	RIB
3718	/	C7X18	/	--	/	27GA	1.75"	THICK	FLUSH	
3720	/	C7X20	/	240U	/	27GA	2"	THICK	MINOR	RIB
3722	/	C0X22	/	--	/	20GA	2"	THICK	FLUSH	
3724	/	C7X24	/	244U	/	24GA	2"	THICK	MINOR	RIB
3730	/	--	/	--	/	27GA	3"	THICK	MINOR	RIB

SHEET:
1 OF 3

THIS PRODUCT CONFORMS TO THE REQUIREMENTS OF 7TH AND 8TH EDITION OF THE FLORIDA BUILDING CODE

REVISIONS					
REV. NO.	ZONE:	DATE:	ECN NO.	APPVD:	DESCRIPTION
06	-	8/28/20	-	SH	UPDATED TITLE BLOCK AND CODE COMPLIANCE STATEMENT TO 7TH.
07	-	9/6/23	-	JDW	UPDATED CODE COMPLIANCE STATEMENT TO ADD 8TH EDITION FBC.
08	-	11/2024	-	MWW	10-YEAR RETEST, RENEWAL & JAMB CALC. UPDATE.
09	-	10/9/25	-	JDW	ADDED 3730 & UPDATED IMPACT RESISTANT WINDOW DETAILS

PRODUCT REVISED
as complying with the Florida Building Code
NOA-No. 26-0313.15
Expiration Date 01/15/2030
By *[Signature]*
Miami-Dade Product Control

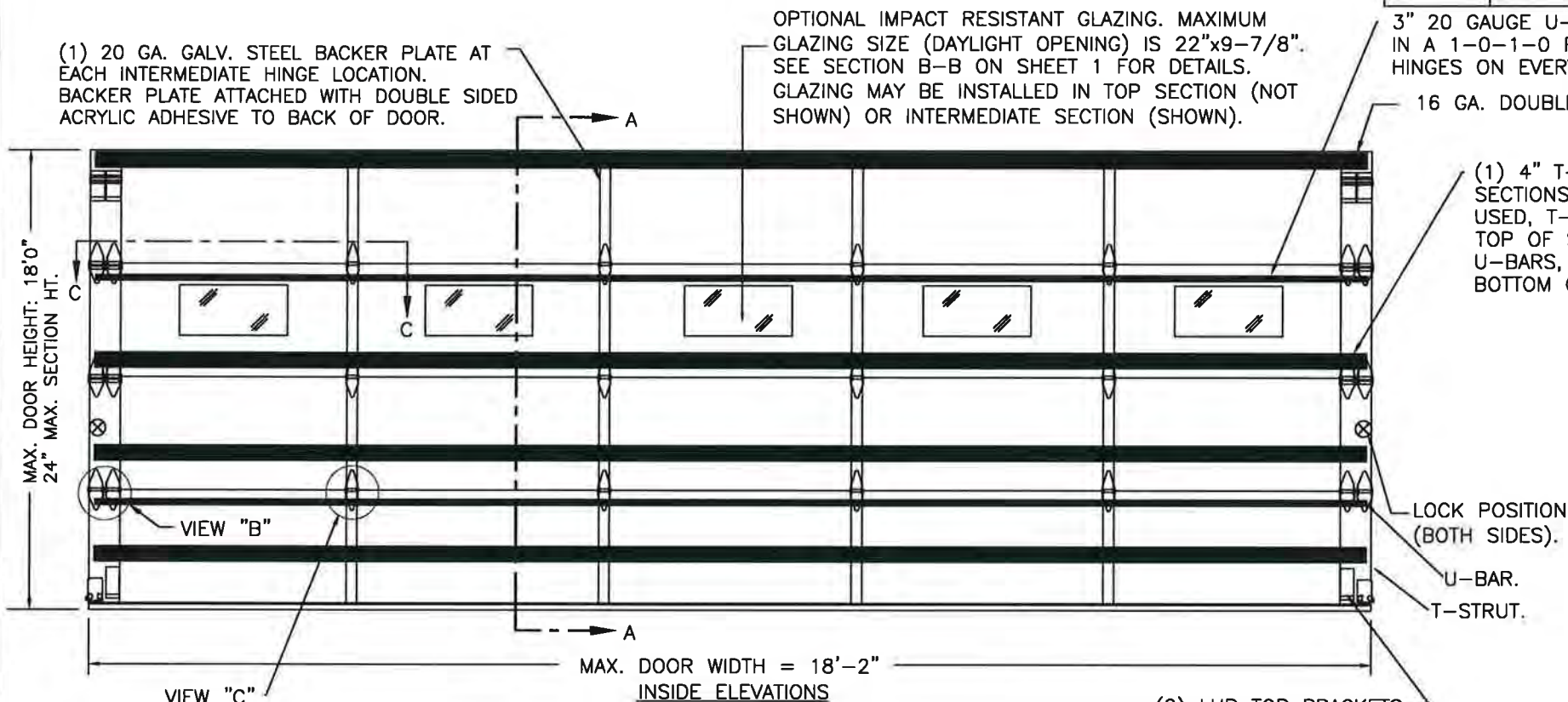

IMPACT-RESISTANT CONSTRUCTION:
SOLID DOORS (NO GLAZING) OR DOORS WITH OPTIONAL IMPACT-RESISTANT GLAZING ARE IMPACT-RESISTANT. OPTIONAL IMPACT RESISTANT ASSEMBLY CONSISTS OF ALUMINUM FRONT FRAME GE LEXAN MR10, AN APPROVED CC1 PLASTIC IN ACCORDANCE WITH IBC/FBC 2606 AND AN APPROVED C1 PLASTIC IN ACCORDANCE WITH FBC 2612. THE ENTIRE DOOR ASSEMBLY INSTALLED IN COMPLIANCE WITH THIS SECTION MEETS THE WIND LOAD REQUIREMENTS OF THE FLORIDA BUILDING CODE AND INTERNATIONAL BUILDING CODE AND IS LARGE- AND SMALL-MISSILE IMPACT RESISTANT.

SECTION B-B (IMPACT-RESISTANT GLAZING OPTION)

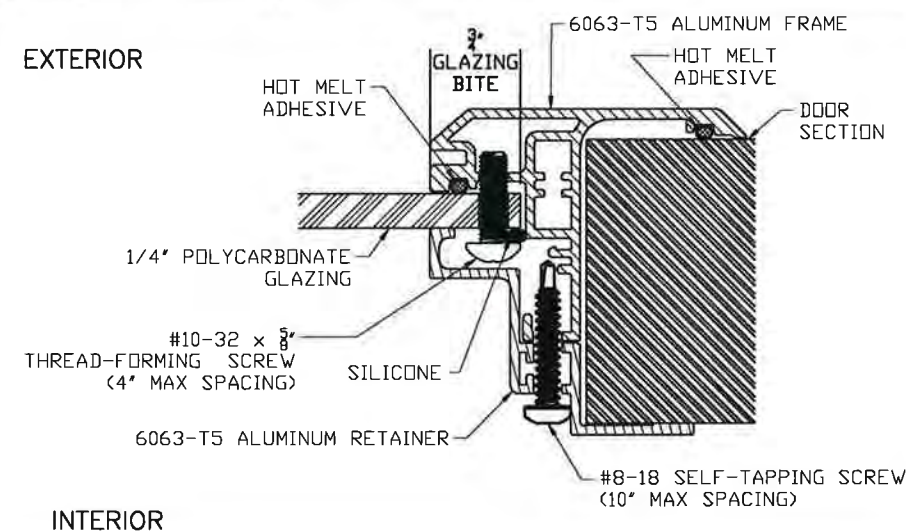

IMPACT-RESISTANT ASSEMBLY DETAILS

DESIGN LOADS: +36.0 P.S.F. & -40.0 P.S.F.

Unless Stated Otherwise TOLERANCES are

.0	= ±.031
.00	= ±.015
.000	= ±.005
.0000	= ±.001
Degrees	= ±1/2'

Unless Stated Otherwise DIMENSIONS ARE IN INCHES.

Glopay CORPORATION
8585 Duke Boulevard
Mason, OH 45040 USA
Tel. No. 513-770-4800
Fax No. 513-770-4853

MANUFACTURING PRODUCT CODE C-DSIU-1D477		
PART NO.: N/A		
WINDLOAD RATING W6 DP36T		
DESCRIPTION: 1-3/4" INTELICORE DOORS UP TO 18'2"W (SEE TABLE)	DWG. SIZE B	
DRAWN BY: SH	DATE: 1/10/13	SCALE: NTS
CHECKED BY: MWW	DATE: 7/28/14	SHEET 1 OF 3
DWG. NO.: 104826	VER: M-D	

DOOR HEIGHT 'A'	NUMBER OF SECTIONS
UP TO 8'-0"	4
8'-3" THRU 10'-0"	5
10'-3" THRU 12'-0"	6
12'-3" THRU 14'-0"	7
14'-3" THRU 16'-0"	8
16'-3" THRU 18'-0"	9

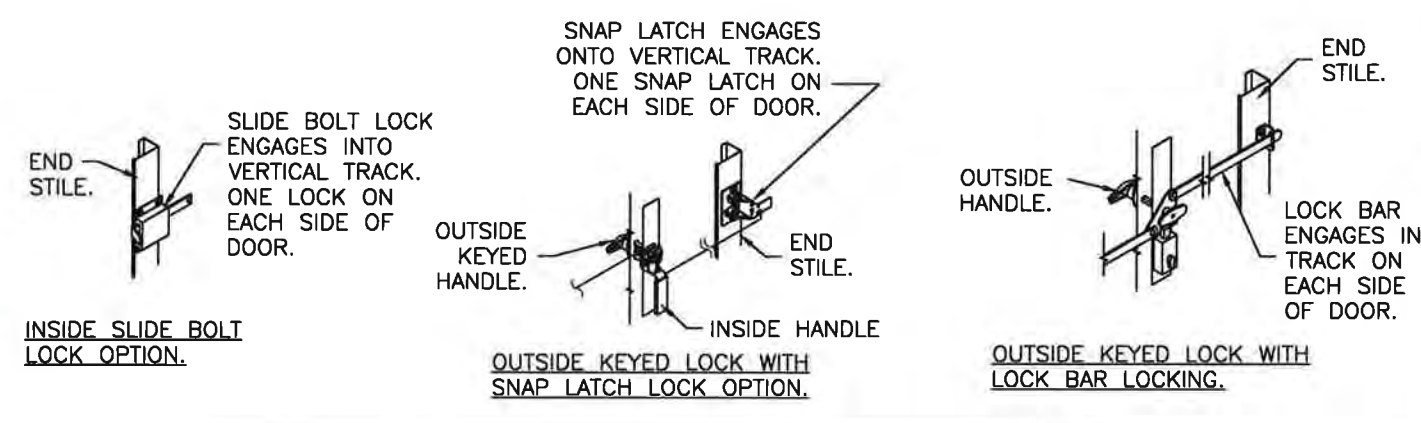
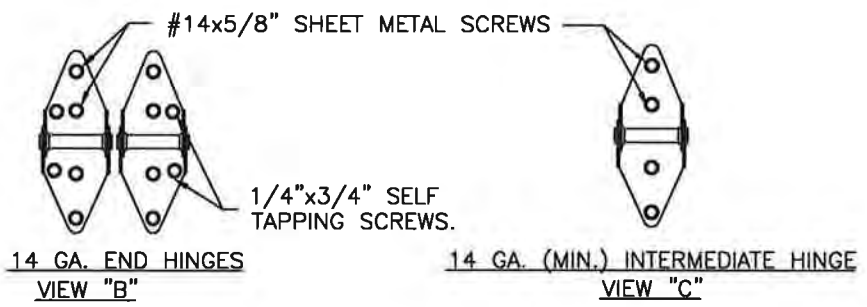

JAMES D. WHEELER
LICENSE
No. 91932
STATE OF FLORIDA
PROFESSIONAL ENGINEER
DESIGN ENGINEER: *[Signature]*
JAMES D. WHEELER, P.E.
FLORIDA LICENSE No. 91932

CLOPAY / IDEAL / HOLMES			
3717 / C7X17 / --	/ 27GA 1.75" THICK MINDR RIB		
3718 / C7X18 / --	/ 27GA 1.75" THICK FLUSH		
3720 / C7X20 / 240U	/ 27GA 2" THICK MINDR RIB		
3722 / COX22 / --	/ 20GA 2" THICK FLUSH		
3724 / C7X24 / 244U	/ 24GA 2" THICK MINDR RIB		
3730 / -- / --	/ 27GA 3" THICK MINDR RIB		

SHEET:
2 OF 3

REVISIONS					
REV. NO.	ZONE:	DATE:	ECN NO.	APPVD:	DESCRIPTION
09	-	-	-	-	SEE REVISION HISTORY ON SHEET ONE.

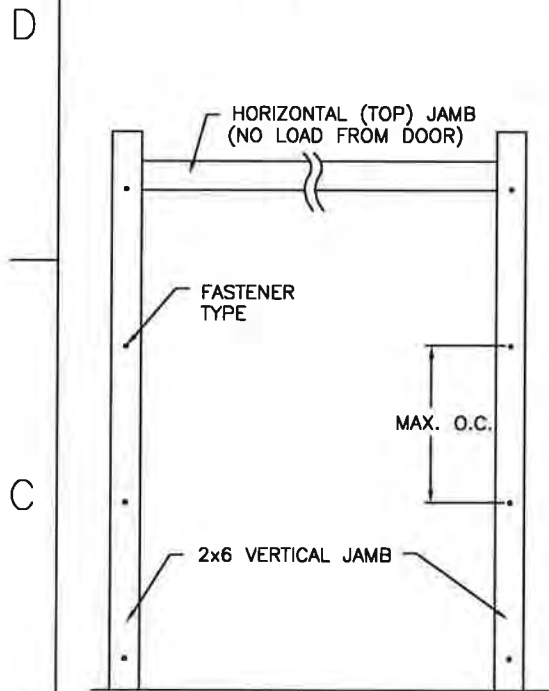

JAMB TO SUPPORTING STRUCTURE ATTACHMENT

NOTES:

1. ALL THE LOAD FROM THE DOOR IS TRANSFERRED TO THE TRACK AND THEN FROM THE TRACK TO THE 2x6 VERTICAL SYP (GRADE #2 OR BETTER) JAMBS. NO LOAD FROM THE DOOR IS TRANSFERRED TO THE HORIZONTAL (TOP) JAMB.
2. EACH VERTICAL JAMB SEES A MAXIMUM DESIGN LOAD OF +324 LB & -360 LB. PER LINEAR FOOT OF JAMB.
3. ALL JAMB FASTENERS MAY BE (BUT ARE NOT REQUIRED TO BE) COUNTERSUNK TO PROVIDE A FLUSH MOUNTING SURFACE.
4. A 1/3 STRESS INCREASE FOR WIND LOAD WAS NOT USED IN THE CALCULATION OF ALLOWABLE LOADS FOR ANCHORS AND FASTENERS FOR STEEL, CONCRETE AND MASONRY.

NOTE: 2x6 WOOD JAMBS ARE NOT REQUIRED WITH CONTINUOUS ANGLE MOUNT TRACK. HOWEVER, IF DESIRED ON STEEL JAMBS OR CONCRETE OR BLOCK WALLS, APPROVED FASTENERS AS DETAILED BELOW SHOULD BE INCREASED IN LENGTH BY 1-1/2" AND INSTALLED DIRECTLY THROUGH THE ANGLE AND 2x6 WOOD JAMBS INTO THE STEEL JAMBS OR CONCRETE OR BLOCK WALLS. ANCHORS CAN BE (BUT ARE NOT REQUIRED TO BE) COUNTERSUNK TO PROVIDE A FLUSH MOUNTING SURFACE. CONTINUOUS ANGLE TRACK CAN BE ANCHORED DIRECTLY TO GROUT REINFORCED BLOCK WALL OR 3,000 PSI MIN. CONCRETE COLUMN OR STEEL JAMBS.

POLYURETHANE FOAM INSULATION (2.4# PCF)

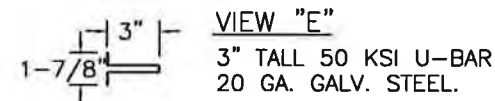
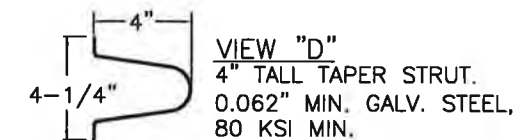

PRODUCT REVISED
as complying with the Florida
Building Code
NOA-No. 26-0313.15
Expiration Date 01/15/2030
By *[Signature]*
Miami-Dade Product Control

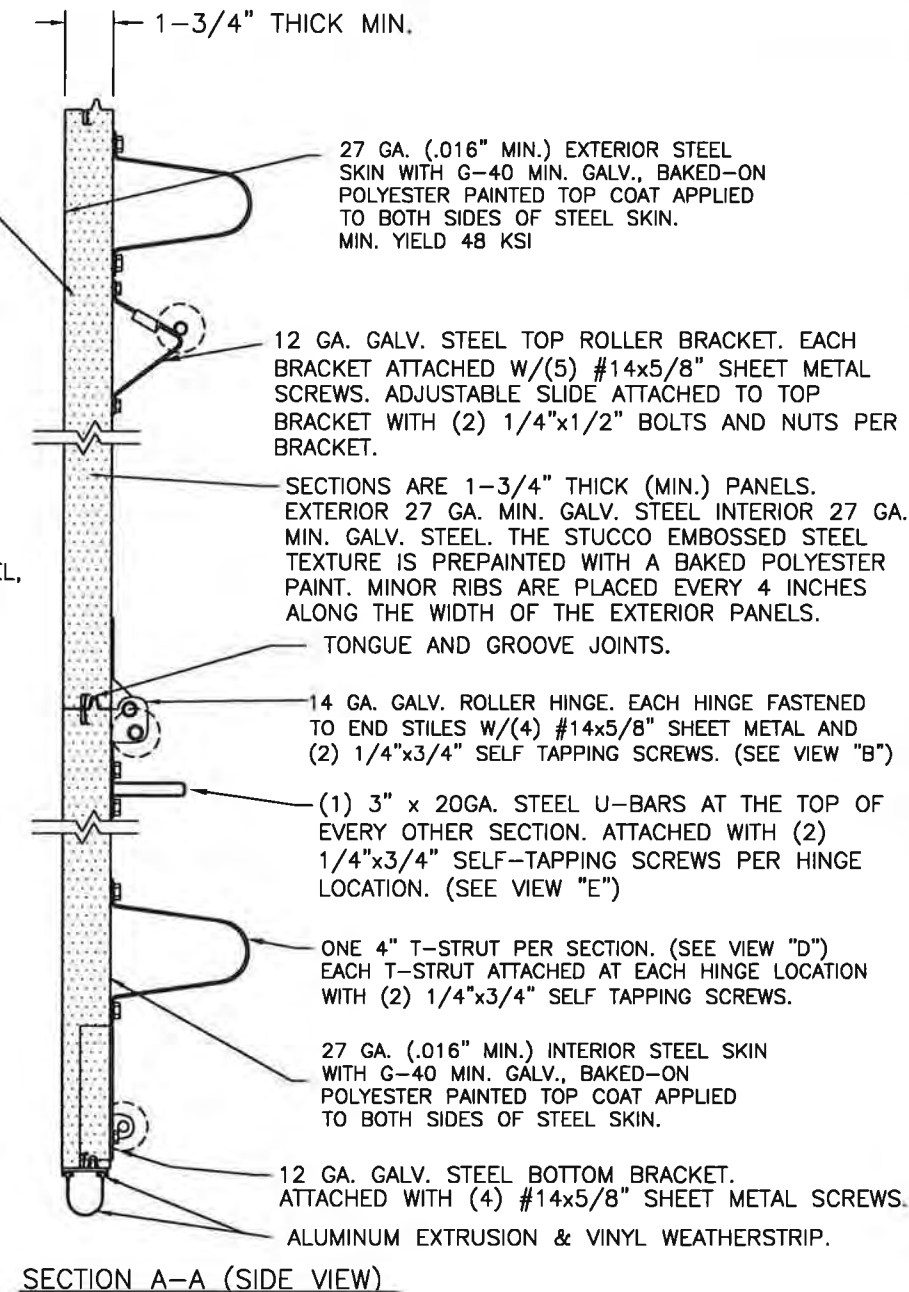

FASTENER ATTACHMENT TO SUPPORTING STRUCTURE SCHEDULES

BUILDING TYPE	FASTENER TYPE	MAXIMUM ON-CENTER DISTANCE BETWEEN FASTENERS*	STEEL WASHERS REQUIRED?
HOLLOW BLOCK WALL	1/4" x 1-1/4" MIN. EMBED CARBON STEEL CONCRETE SCREW	6-1/2"	1" O.D.
GROUT FILLED BLOCK WALL	1/4" x 1-3/4" MIN. EMBED CARBON STEEL CONCRETE SCREW	13-1/2"	1" O.D.
2000 PSI MIN. CONCRETE	1/4" x 1-3/4" MIN. EMBED TAPCON CONCRETE ANCHOR	16-1/4"	1" O.D.
4000 PSI MIN. CONCRETE	1/4" x 1-3/4" MIN. EMBED TAPCON CONCRETE ANCHOR	22"	1" O.D.
2500 PSI MIN. CONCRETE	3/8" x 3" NOMINAL EMBED HILTI KWIK BOLT T22 CONCRETE ANCHOR	24"	INCLUDED
WOOD FRAME (SYP 0.55 SG)	1/2" x 1-1/2" EMBED LAG SCREW (ASTM A307, GRADE A)	19-1/4"	1" O.D.
14GA STEEL (0.060" MIN.)	1/4"-14 x 1" ITW BUILDDEX TEKS SELF-DRILLING FASTENER	8-3/4"	1" O.D.
12GA STEEL (0.105" MIN.)	1/4"-14 x 1" ITW BUILDDEX TEKS SELF-DRILLING FASTENER	12"	1" O.D.
1/8" STEEL	1/4"-14 x 1" ITW BUILDDEX TEKS SELF-DRILLING FASTENER	14-1/2"	1" O.D.

* FIRST (BOTTOM) ANCHOR STARTING AT NO MORE THAN HALF OF THE MAXIMUM ON-CENTER DISTANCE. HIGHEST ANCHOR INSTALLED AT LEAST AS HIGH AS THE DOOR OPENING.
CLOPAY DOES NOT SUPPLY JAMB ATTACHMENT FASTENERS.
MINIMUM DISTANCE BETWEEN CENTER OF ANCHOR AND EDGE OF CONCRETE BLOCK: 2-1/2", EXCLUDING STUCCO THICKNESS.

DESIGN LOADS: +36.0 P.S.F. & -40.0 P.S.F.

Unless Stated Otherwise
TOLERANCES are
.0 = ±.031
.00 = ±.015
.000 = ±.005
.0000 = ±.001
Degrees = ±1/2'
Unless Stated Otherwise
DIMENSIONS ARE IN INCHES.

Glopay CORPORATION
8585 Duke Boulevard
Mason, OH 45040 USA
Tel. No. 513-770-4800
Fax No. 513-770-4853

MANUFACTURING PRODUCT CODE
C-DSIU-1D477

PART NO.: N/A

WINDLOAD RATING
W6 DP36T

DESCRIPTION: 1-3/4" INTELLICORE DOORS UP TO 18'2"W (SEE TABLE)

DRAWN BY: SH DATE: 1/10/13 SCALE: NTS DWG. SIZE B

CHECKED BY: MWW DATE: 7/28/14 SHEET 2 OF 3

DWG. NO.: 104826 VER: M-D

JAMES D. WHEELER
LICENSE
No. 91932
STATE OF FLORIDA
PROFESSIONAL ENGINEER

DESIGN ENGINEER: *[Signature]*
JAMES D. WHEELER, P.E.
FLORIDA LICENSE No. 91932

CLOPAY / IDEAL / HOLMES
3717 / C7X17 / --- / 27GA 1.75" THICK MINDR RIB
3718 / C7X18 / --- / 27GA 1.75" THICK FLUSH
3720 / C7X20 / 240U / 27GA 2" THICK MINDR RIB
3722 / COX22 / --- / 20GA 2" THICK FLUSH
3724 / C7X24 / 244U / 24GA 2" THICK MINDR RIB
3730 / --- / --- / 27GA 3" THICK MINDR RIB

SHEET:
3 OF 3

REVISIONS				
REV. NO.	ZONE	DATE	ECN NO.	APPVD.
09	-	-	-	-
SEE REVISION HISTORY ON SHEET ONE.				

PRODUCT REVISED
as complying with the Florida Building Code
NOA-No. 26-0313.15
Expiration Date 01/15/2030
By *[Signature]*
Miami-Dade Product Control

2" TRACK CONFIGURATION
DOORS UP TO 800 LBS.

NOTE DOUBLE TRACK HEADROOM, HI-LIFT TRACK, FOLLOW-THE-ROOF TRACK, AND VERTICAL LIFT TRACK ARE AVAILABLE OPTIONS. TRACK CONFIGURATION ABOVE THE DOOR OPENING DOES NOT AFFECT THE WIND LOAD RATING.

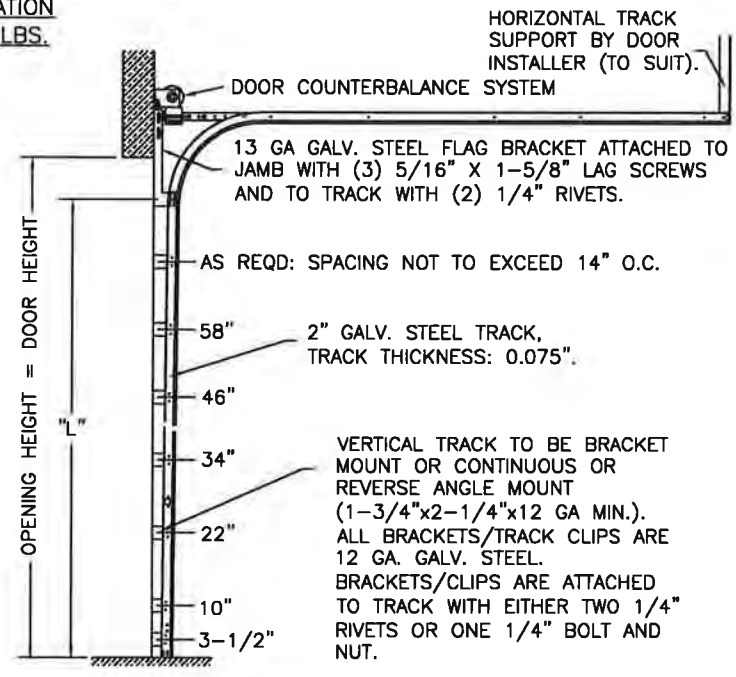

DOOR HEIGHT	"L"
6'-6"	70"
7'-0"	76"
7'-6"	82"
8'-0"	88"
8'-6"	94"
9'-0"	100"
9'-6"	106"
10'-0"	112"
10'-6"	118"
11'-0"	124"
11'-6"	130"
12'-0"	136"
12'-6"	142"
13'-0"	148"
13'-6"	154"
14'-0"	160"
14'-6"	166"
15'-0"	172"
15'-6"	178"
16'-0"	184"
16'-6"	190"
17'-0"	196"
17'-6"	202"
18'-0"	208"

JAMB CONFIGURATION
DOORS UP TO 800 LBS.

BRACKET MOUNT JAMB CONFIGURATION

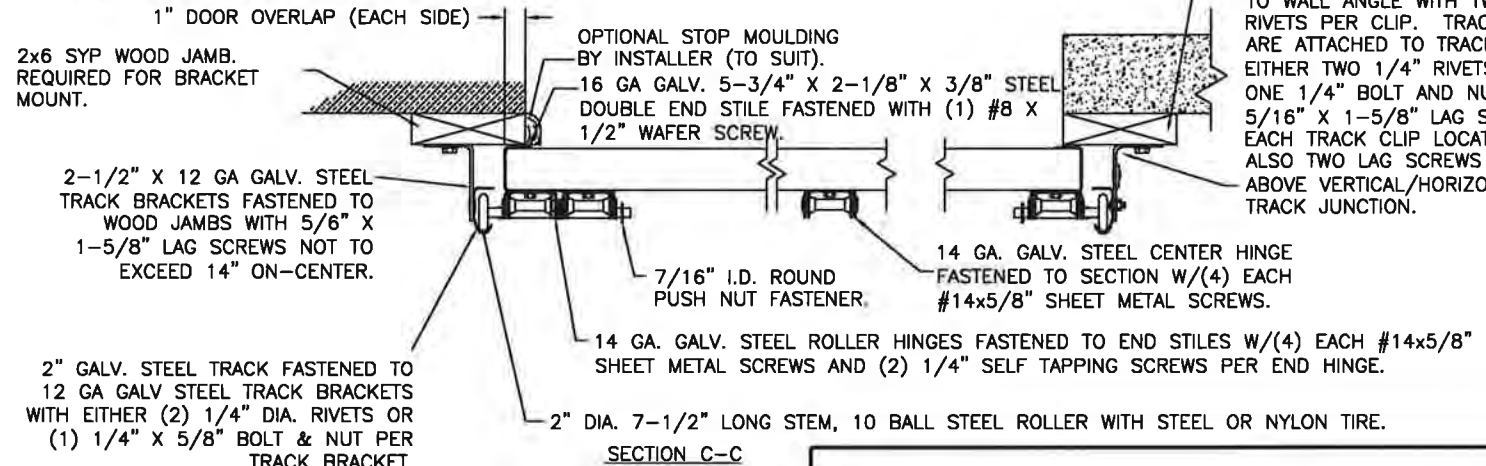

ANGLE MOUNT JAMB CONFIGURATION

2x6 SYP JAMB (IF PRESENT; SEE JAMB NOTES ON SHEET 2).
VERTICAL TRACK TO BE CONTINUOUS OR REVERSE ANGLE. 12 GA. TRACK CLIPS ATTACHED TO WALL ANGLE WITH TWO 1/4" RIVETS PER CLIP. TRACK CLIPS ARE ATTACHED TO TRACK WITH EITHER TWO 1/4" RIVETS OR ONE 1/4" BOLT AND NUT. ONE 5/16" X 1-5/8" LAG SCREW AT EACH TRACK CLIP LOCATION. ALSO TWO LAG SCREWS LOCATED ABOVE VERTICAL/HORIZONTAL TRACK JUNCTION.

3" TRACK CONFIGURATION
DOORS 800 LBS AND OVER.

NOTE DOUBLE TRACK HEADROOM, HI-LIFT TRACK, FOLLOW-THE-ROOF TRACK, AND VERTICAL LIFT TRACK ARE AVAILABLE OPTIONS. TRACK CONFIGURATION ABOVE THE DOOR OPENING DOES NOT AFFECT THE WIND LOAD RATING.

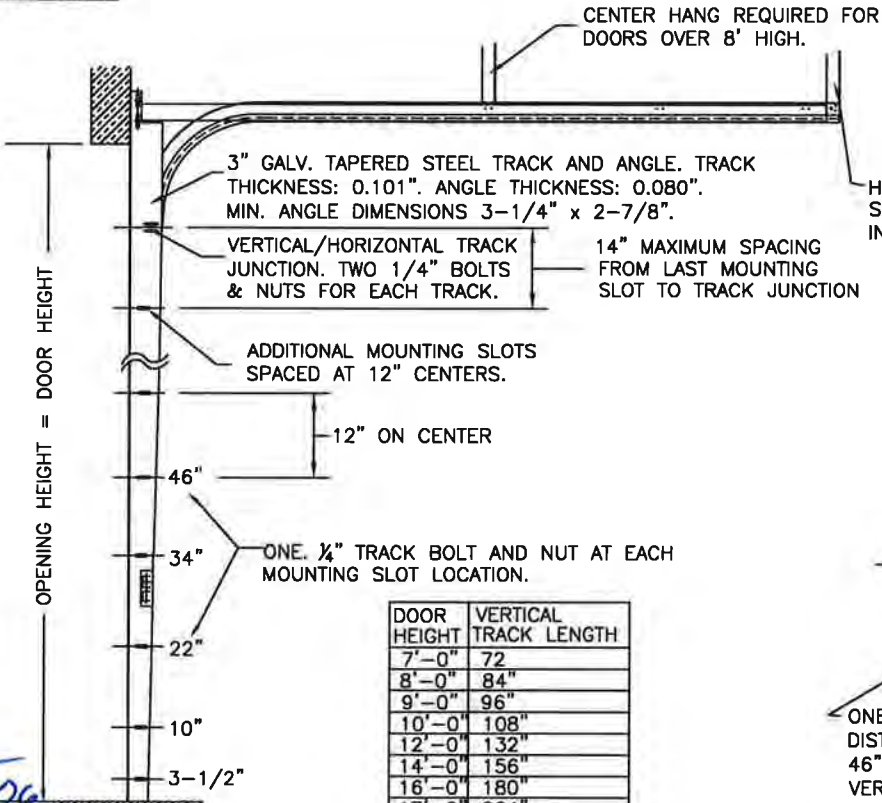

JAMB CONFIGURATION
DOORS 800 LBS AND OVER.

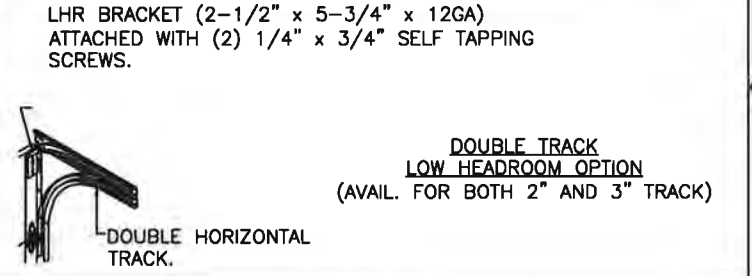
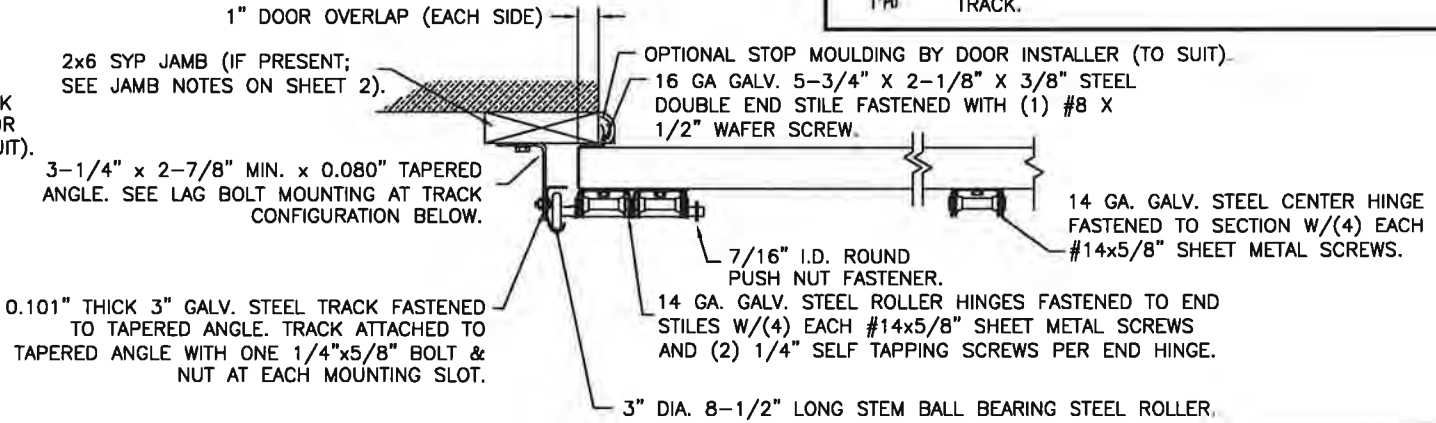

JAMES D. WHEELER
LICENSE
No. 91932
STATE OF FLORIDA
PROFESSIONAL ENGINEER
DESIGN ENGINEER: *[Signature]*
JAMES D. WHEELER, P.E.
FLORIDA LICENSE No. 91932

DOOR HEIGHT	VERTICAL TRACK LENGTH
7'-0"	72"
8'-0"	84"
9'-0"	96"
10'-0"	108"
12'-0"	132"
14'-0"	156"
16'-0"	180"
17'-0"	204"
18'-0"	228"

ONE 5/16" x 1-5/8" LAG SCREW SPACED AT THE SAME DISTANCES AS THE TRACK BOLTS (I.E. 3-1/2", 10", 22", 34", 46", ETC.). TWO LAG SCREWS ALSO LOCATED ABOVE VERTICAL/HORIZONTAL TRACK JUNCTION.

DESIGN LOADS: +36.0 P.S.F. & -40.0 P.S.F.

Unless Stated Otherwise
TOLERANCES are
.0 = ±.031
.00 = ±.015
.000 = ±.005
.0000 = ±.001
Degrees = ±1/2"
Unless Stated Otherwise
DIMENSIONS ARE IN INCHES.

Clopay CORPORATION
8585 Duke Boulevard
Mason, OH 45040 USA
Tel. No. 513-770-4800
Fax No. 513-770-4853

DESCRIPTION: 1-3/4" INTELLICORE DOORS UP TO 18'2"W (SEE TABLE)	
DRAWN BY: SH	DATE: 1/10/13
CHECKED BY: MWW	DATE: 7/28/14
DWG. NO.: 104826	VER: M-D

MANUFACTURING PRODUCT CODE C-DSIU-1D477
PART NO.: N/A
WINDLOAD RATING W6 DP36T