



DEPARTMENT OF REGULATORY AND ECONOMIC RESOURCES (RER)
BOARD AND CODE ADMINISTRATION DIVISION
NOTICE OF ACCEPTANCE (NOA)

MIAMI-DADE COUNTY
PRODUCT CONTROL SECTION
11805 SW 26 Street, Room 208
Miami, Florida 33175-2474
T (786) 315-2590 F (786) 315-2599
www.miamidade.gov/building

Nailor Industries of Texas, Inc.
4714 Winfield Road
Houston, TX 77039

SCOPE: This NOA is being issued under the applicable rules and regulations governing the use of construction materials. The documentation submitted has been reviewed and accepted by Miami-Dade County RER-Product Control Section to be used in Miami Dade County and other areas where allowed by the Authority Having Jurisdiction (AHJ).

This NOA shall not be valid after the expiration date stated below. The Miami-Dade County Product Control Section (In Miami Dade County) and/or the AHJ (in areas other than Miami Dade County) reserve the right to have this product or material tested for quality assurance purposes. If this product or material fails to perform in the accepted manner, the manufacturer will incur the expense of such testing and the AHJ may immediately revoke, modify, or suspend the use of such product or material within their jurisdiction. RER reserves the right to revoke this acceptance if it is determined by Miami-Dade County Product Control Section that this product or material fails to meet the requirements of the applicable building code.

This product is approved as described herein and has been designed to comply with the Florida Building Code, including the High Velocity Hurricane Zone.

DESCRIPTION: Model 1605WDVM Aluminum Louver

APPROVAL DOCUMENT: Drawing No. **1605WDVM**, titled "1605WDVM Louver", sheets 1 through 12 of 12, dated 04/30/2026, prepared by manufacturer, signed and sealed by Wayne K. Helmila, P.E., bearing the Miami-Dade County Product Control revision stamp with the Notice of Acceptance number and expiration date by the Miami-Dade County Product Control Section.

MISSILE IMPACT RATING: Large and Small Missile Impact Resistant

LABELING: Each unit shall bear a permanent label with the manufacturer's name or logo, Houston, TX, model/series, and following statement: "Miami-Dade County Product Control Approved", unless otherwise noted herein.

LIMITATION: This system is to be installed in a location where the room behind the louver is designed to drain water penetrating into the room, and the room will house water resistant/waterproof equipment, components, or supplies.

RENEWAL of this NOA shall be considered after a renewal application has been filed and there has been no change in the applicable building code negatively affecting the performance of this product.

TERMINATION of this NOA will occur after the expiration date or if there has been a revision or change in the materials, use, and/or manufacture of the product or process. Misuse of this NOA as an endorsement of any product, for sales, advertising or any other purposes shall automatically terminate this NOA. Failure to comply with any section of this NOA shall be cause for termination and removal of NOA.

ADVERTISEMENT: The NOA number preceded by the words Miami-Dade County, Florida, and followed by the expiration date may be displayed in advertising literature. If any portion of the NOA is displayed, then it shall be done in its entirety.

INSPECTION: A copy of this entire NOA shall be provided to the user by the manufacturer or its distributors and shall be available for inspection at the job site at the request of the Building Official. This NOA **revises NOA No. 24-0516.06** and consists of this page 1 and evidence pages E-1 and E-2, as well as approval document mentioned above.

The submitted documentation was reviewed by **Carlos M. Utrera, P.E.**



06/15/26

NOA No. 26-0518.09
Expiration Date: August 30, 2028
Approval Date: June 25, 2026

Nailor Industries of Texas, Inc.

NOTICE OF ACCEPTANCE: EVIDENCE SUBMITTED

1. EVIDENCE SUBMITTED UNDER NOA # 18-0117.14

A. DRAWINGS

1. Drawing No. **1605WDVM**, titled “1605WDVM Louver”, sheets 1 through 11 of 11, dated 10/12/17, prepared by the manufacturer, signed and sealed by Wayne K. Helmila,

B. TESTS

1. Test reports on: 1) Uniform Static Air Pressure Test, Loading per FBC, TAS 202-94
2) Large Missile Impact Test per FBC, TAS 201-94
3) Cyclic Wind Pressure Loading per FBC, TAS 203-94
along with installation diagram of Model 1605 WDVM Louver System, prepared by Intertek, Test Report No. **H4892.01-801-18-R4**, dated 09/25/17 and revised on 05/18/18, signed and sealed by Tyler Westerling, P.E.
2. Test Report on Wind Driven Rain Resistance per TAS 100(A)-95 on a Model 1605WDVM Vertical Aluminum Louver, prepared by Intertek, Test Report No. **H0211.02-801-18 R1**, dated 09/27/17 and revised on 11/21/17, signed and sealed by Tyler Westerling, P.E.
3. Test Report on High Velocity Wind Driven Rain Resistance per ANSI/AMCA 550-09 on a Model 1605WDVM Vertical Aluminum Louver, prepared by Intertek/ATI, Test Report No. **H0211.01-801-18-R3**, dated 04/20/17 and revised on 11/21/17, signed and sealed by Tyler Westerling, P.E.

C. CALCULATIONS

1. Louver structural calculations dated 11/03/17, prepared by Rice Engineering, signed and sealed by Wayne K. Helmila, P.E

D. QUALITY ASSURANCE

1. Miami-Dade Department of Regulatory and Economic Resources (RER).

E. MATERIAL CERTIFICATIONS

1. None.

F. STATEMENTS

1. Statement letter of code conformance to the **FBC 6th Edition (2017)** issued by Rice Engineering, dated 04/16/18, signed and sealed by Wayne K. Helmila, P.E.
2. Statement letter of no financial interest issued by Rice Engineering, dated 04/16/18, signed and sealed by Wayne K. Helmila, P.E.



Carlos M. Utrera, P.E.
Product Control Examiner
NOA No. 26-0518.09
Expiration Date: August 30, 2028
Approval Date: June 25, 2026

NOTICE OF ACCEPTANCE: EVIDENCE SUBMITTED

2. EVIDENCE SUBMITTED UNDER NOA # 21-0630.12 AND NEW

A. DRAWINGS

1. Drawing No. **1605WDVM**, titled “1605WDVM Louver”, sheets 1 through 12 of 12, dated 04/30/2026, prepared by manufacturer, signed and sealed by Wayne K. Helmila, P.E.

B. TESTS

1. None.

C. CALCULATIONS

1. Louver calculations, prepared by Rice Engineering, dated 04/29/2024, signed and sealed by Wayne K. Helmila, P.E.

D. QUALITY ASSURANCE

1. Miami-Dade Department of Regulatory and Economic Resources (RER).

E. MATERIAL CERTIFICATIONS

1. None.

F. STATEMENTS

1. Statement letter of code conformance to the 8th edition (2023) of the FBC, issued by Rice Engineering, dated 04/29/2024, signed and sealed by Wayne K. Helmila, P.E.
2. Statement letter of no financial interest, issued by Rice Engineering, dated 04/29/2024, signed and sealed by Wayne K. Helmila, P.E.

“Submitted under NOA # 21-0630.12”

3. Statement letter of code conformance to the **7th edition (2020) FBC**, issued by Rice Engineering, dated 08/16/21, signed and sealed by Wayne K. Helmila, P.E.



Carlos M. Utrera, P.E.
Product Control Examiner
NOA No. 26-0518.09
Expiration Date: August 30, 2028
Approval Date: June 25, 2026

The following pages in this document were submitted by the manufacturer (third party) to represent the product being approved and establish the limits of use. The pages may include technical drawings, schematics and installation details.

DRAWING INDEX

1. INDEX TO DRAWINGS AND NOTES
2. 1605WDVM LOUVER - ELEVATION
3. 1605WDVM LOUVER - HEAD AND SILL DETAIL
4. 1605WDVM LOUVER - SKINNY WALL APPLICATION HEAD AND SILL DETAIL
5. 1605WDVM LOUVER - SKINNY WALL APPLICATION HEAD AND SILL DETAIL CONT.
6. 1605WDVM LOUVER - JAMB AND MULLION DETAIL
7. 1605WDVM LOUVER - BLADE STRAP DETAIL
8. 1605WDVM LOUVER - BAFFLE/ WEEP DETAIL
9. 1605WDVM LOUVER - SEALANT DETAIL
10. 1605WDVM LOUVER - PART PROFILES
11. 1605WDVM LOUVER - BILL OF MATERIAL AND GENERAL NOTES
12. 1605WDVM LOUVER - FASTENER SCHEDULE

NOTES:

1. THE 1605WDVM HAS BEEN TESTED IN ACCORDANCE WITH THE MIAMI-DADE COUNTY PROTOCOLS: TAS-100 A, TAS-201, TAS-202, & TAS-203 FOR WIND DRIVEN RAIN, LARGE MISSILE IMPACT, UNIFORM PRESSURE, AND CYCLIC WIND PRESSURE.
2. THIS LOUVER SYSTEM IS APPROVED FOR APPLICATIONS WITH DESIGN PRESSURES OF +/- 130 PSF OR LESS.
3. THIS LOUVER SYSTEM IS NON-BEARING AND IS NOT DESIGNED TO WITHSTAND BUILDING DEAD LOADS.
4. LOUVER ANCHORS ARE REVIEWED FOR ATTACHMENT INTO STEEL, CONCRETE, MASONRY, OR TIMBER STRUCTURE. MINIMUM EDGE DISTANCE AND EMBEDMENT REQUIREMENTS ARE SHOWN. NAILOR INDUSTRIES OF TEXAS DOES NOT DETERMINE THE STRUCTURE INTERGRITY OF THE SUBSTRUCTURE.
5. MAXIMUM SINGLE SECTION SIZE: 72" WIDE X 120" HIGH OR 120" WIDE X 72" HIGH.
6. MAXIMUM ASSEMBLED LOUVER SIZE UNLIMITED WIDE X 120" HIGH MAX. MULLION SPACING IS 72".
7. SECTIONS OR ASSEMBLIES MAY BE STACKED VERTICALLY PROVIDED A SUITABLE STRUCTURE STRUCTURAL SUPPORT IS DESIGNED AND INSTALLED BY OTHERS TO SUPPORT ALL LOADS TRANSFERRED FOR THE LOUVER.

TESTS PERFORMED:
 TAS-100 (A) WIND DRIVEN RAIN RESISTANCE
 TAS-201 LARGE MISSILE IMPACT
 TAS-202 UNIFORM STATIC AIR PRESSURE TEST
 TAS-203 CYCLIC WIND PRESUSRE TEST
 DESIGN PRESSURE RATING 130 PSF

DWN BY: fcortinas

DATE: 4/30/2026

CHK BY: BDennis

SCALE: NTS

SHEET: 1 OF 12

DWG. NO.

1605WDVM

REV

B

PRIVATE & CONFIDENTIAL
 DO NOT REPRODUCE WITHOUT THE PERMISSION OF
Nailor Industries of Texas, Inc.
 Houston, TX 77039
 4714 Winfield Road
 TEL: 281-590-1172 FAX: 281-590-3086
 www.nailor.com

TITLE:
 1605WDVM LOUVER
 INDEX

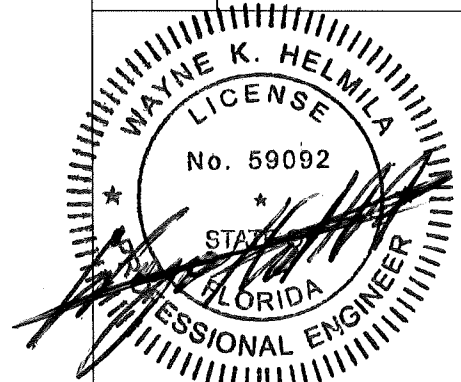

JUN 10 2026

PRODUCT REVISED
 as complying with the Florida
 Building Code

NOA-No. 26-0518.09

Expiration Date 08/30/2028

By *[Signature]*
 Miami-Dade Product Control

RICE
 ENGINEERING

105 School Creek Trail
 Luxemburg, WI 54217
 Phone: (920) 617-1042
 Fax: (920) 617-1100
 www.rice-inc.com

Florida Firm No: F-01000005061
 Certificate of Authorization: #9090
 Wayne K. Helmila
 Registration No: 59092

REVISIONS:

- REV B: ADDED PAGE 5 AND RENUMBERED PAGES 6-12
 - ADDED PAGE 5 SKINNY WALL APPLICATION HEAD AND SILL DETAIL CONT.
 -UPDATED ALL PAGES.

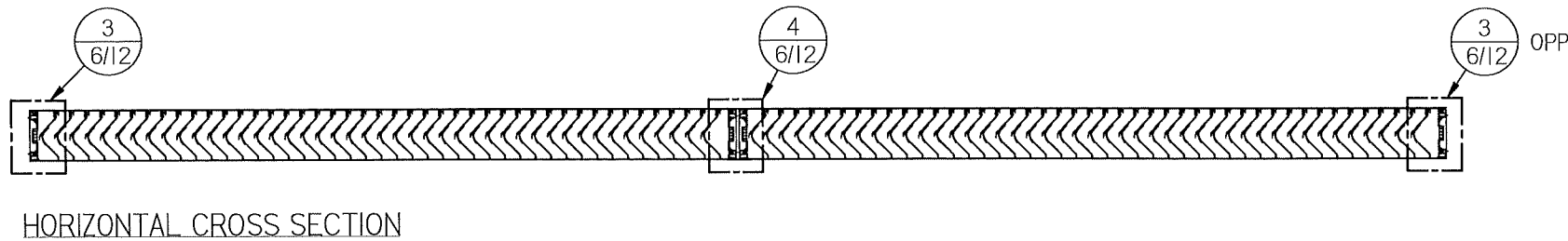

HORIZONTAL CROSS SECTION

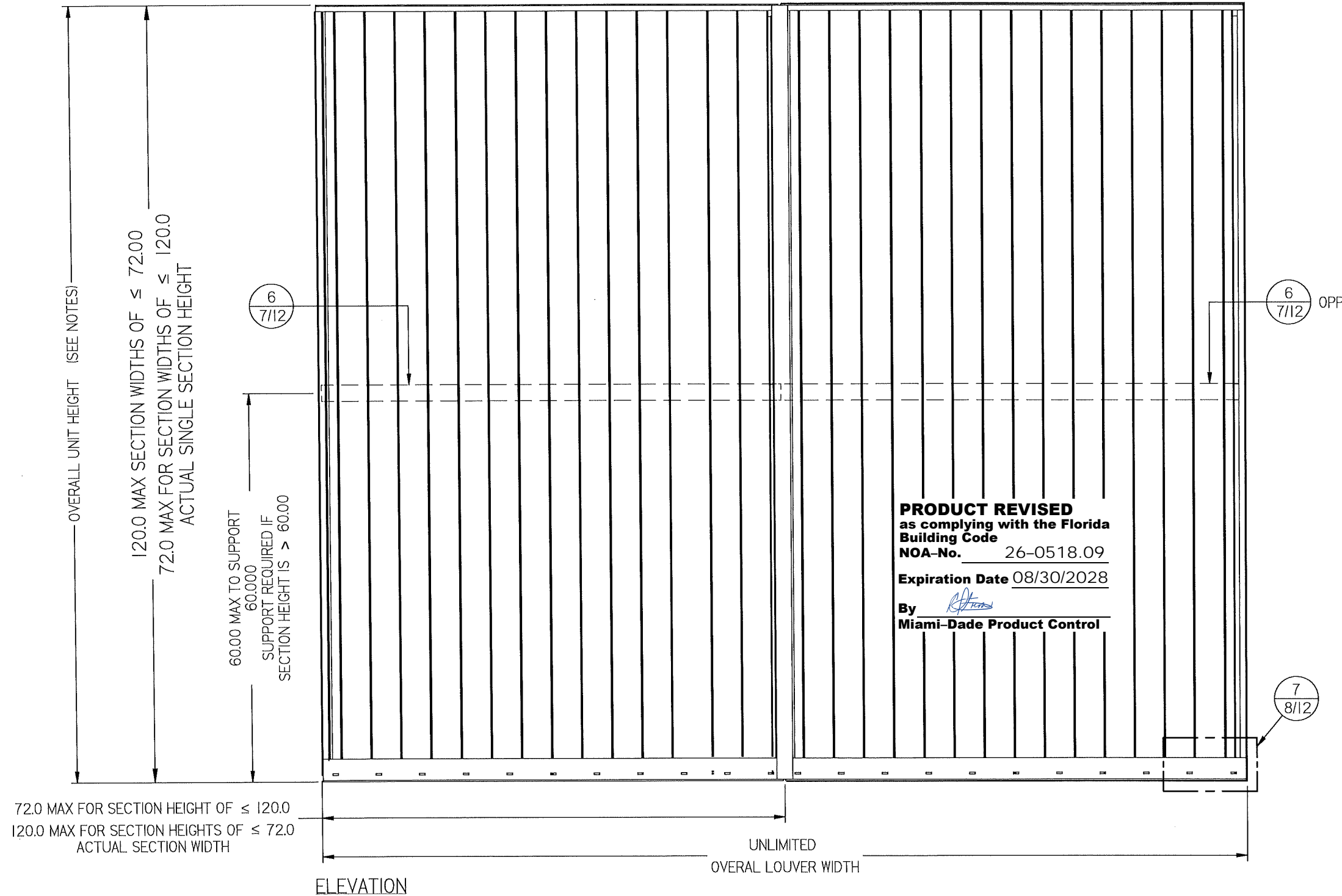

ELEVATION

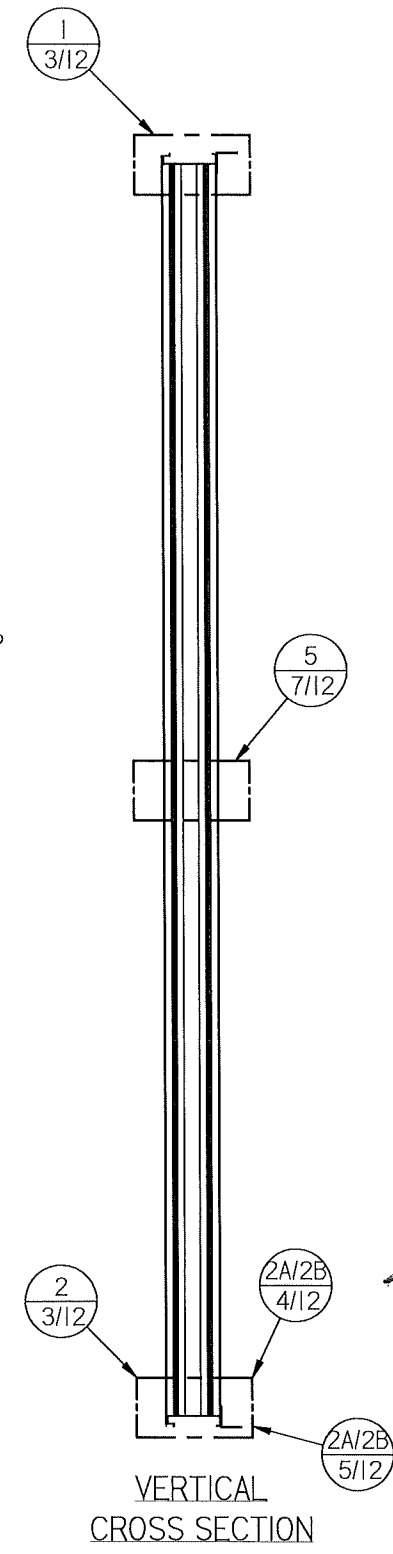

VERTICAL CROSS SECTION

PRODUCT REVISED
 as complying with the Florida
 Building Code
 NOA-No. 26-0518.09
 Expiration Date 08/30/2028
 By *[Signature]*
 Miami-Dade Product Control

PRIVATE & CONFIDENTIAL
 DO NOT REPRODUCE WITHOUT THE PERMISSION OF
Nailor Industries of Texas, Inc.
 4714 Winfield Road
 Houston, TX 77039
 TEL: 281-590-1172 FAX 281-590-3086
 www.nailor.com

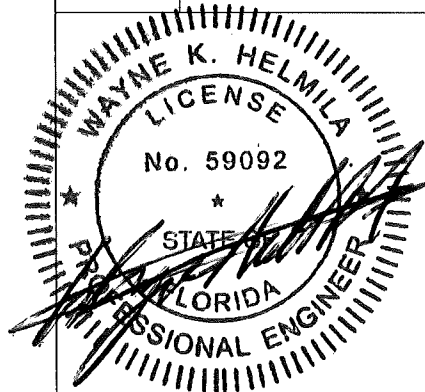

JUN 10 2026

RICE
 ENGINEERING

105 School Creek Trail
 Luxemburg, WI 54217
 Phone: (920) 617-1042
 Fax: (920) 617-1100
 www.rice-inc.com

Florida Firm No: F-0100005061
 Certificate of Authorization: #9090
 Wayne K. Helmila
 Registration No: 59092

DWN BY: fcortinas	CHK BY: BDennis
DATE: 4/30/2026	SCALE: NTS
SHEET: 2 OF 12	
DWG. NO.	REV
1605WDVM	B

TITLE:
 1605WDVM LOUVER
 ELEVATION

ALTERNATE ORIENTATION OF ITEM 5. HEAD OR SILL SEE DOWNSIZING NOTE

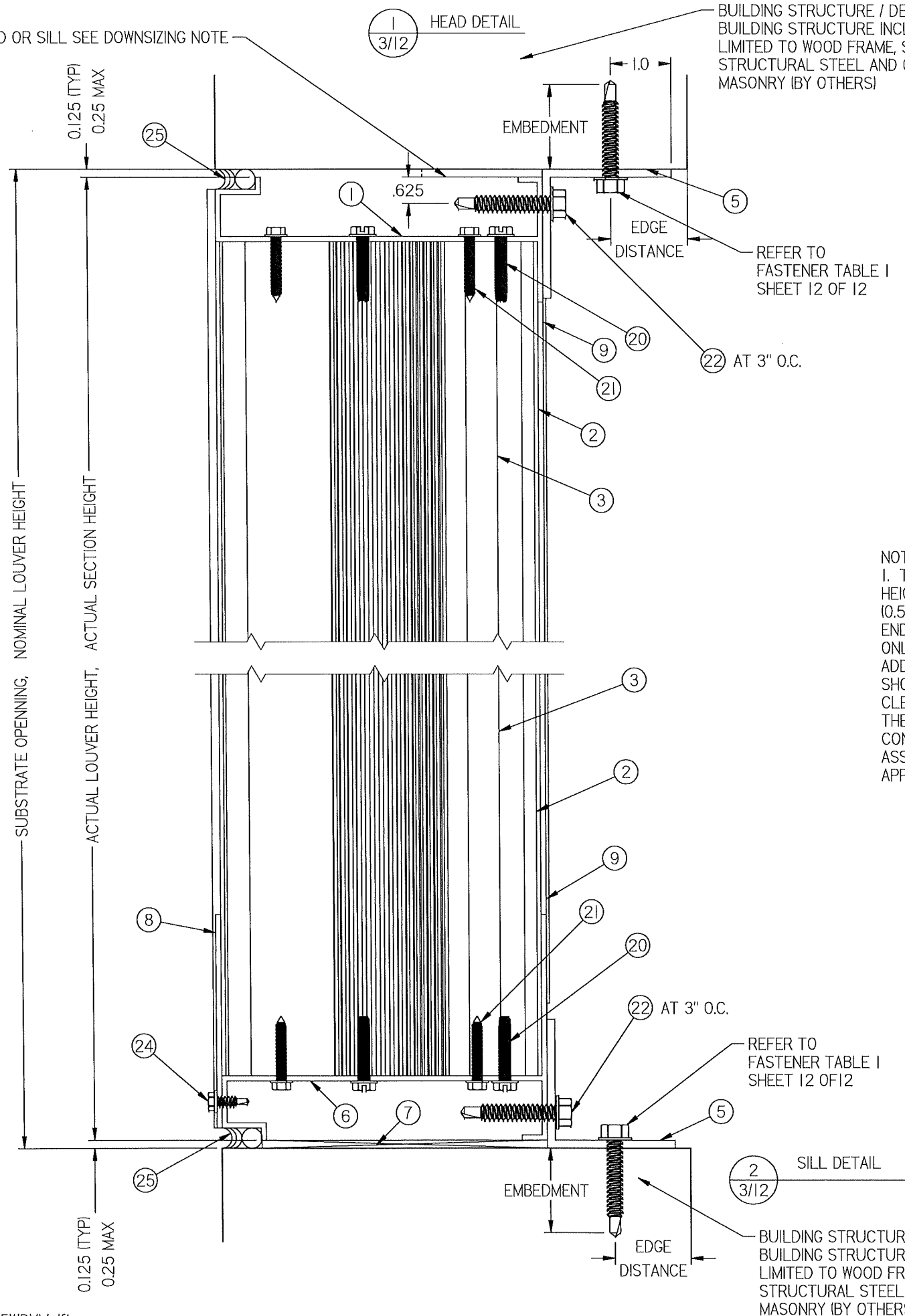

BUILDING STRUCTURE / DEPTH MAY VARY. BUILDING STRUCTURE INCLUDE BUT NOT LIMITED TO WOOD FRAME, STEEL STUDS, STRUCTURAL STEEL AND CONCRETE / MASONRY (BY OTHERS)

REFER TO FASTENER TABLE 1 SHEET 12 OF 12

NOTE:
 1. TO ALLOW FOR SUBSTRATE ANCHOR HEAD CLEARANCE, LOUVER HEIGHT DOWNSIZING (UNDERCUT) OF UP TO 0.25 TOTAL PER END (0.50 OVERALL TOTAL) IS ALLOWABLE. DOWNSIZING OF 0.125 PER END (0.25 OVERALL TOTAL) FROM ACTUAL HEIGHT IS STANDARD. ONLY ENDS WITH ALTERNATE ANCHOR ORIENTATION MAY REQUIRE ADDITIONAL DOWNSIZING, BUT THE 0.125 STANDARD DOWNSIZING SHOULD ALLOW FOR ALTERNATE ANCHOR ORIENTATION SETUP CLEARANCES. THERE IS NO NEED FOR ADDITIONAL DOWNSIZING AT THE JAMBS WHEN USING ALTERNATE ANCHOR ORIENTATION. CONSULT YOUR LOCAL REP OR THE MANUFACTURER IF ASSISTANCE IS NEEDED FOR PROPER DOWNSIZING FOR YOUR APPLICATION.

PRODUCT REVISED
 as complying with the Florida Building Code
 NOA-No. 26-0518.09
 Expiration Date 08/30/2028
 By *[Signature]*
 Miami-Dade Product Control

REFER TO FASTENER TABLE 1 SHEET 12 OF 12

BUILDING STRUCTURE / DEPTH MAY VARY. BUILDING STRUCTURE INCLUDE BUT NOT LIMITED TO WOOD FRAME, STEEL STUDS, STRUCTURAL STEEL AND CONCRETE / MASONRY (BY OTHERS)

REV. B- UPDATED ADDED NOTE #2 TO REFLECT CALC. -UPDATED FASTENER NOTE TO REFLECT CHANGES TO FASTENER TABLES.

DWN BY: fcortinas	CHK BY: BDennis
DATE: 4/30/2026	SCALE: NTS
SHEET: 3 OF 12	
DWG. NO.	REV
1605WDVM	B

PRIVATE & CONFIDENTIAL
 DO NOT REPRODUCE WITHOUT THE PERMISSION OF
Nailor Industries of Texas, Inc.
 Houston, TX 77039
 4714 Winfield Road
 TEL: 281-590-1172
 FAX: 281-590-3086
 www.nailor.com

TITLE:
 1605WDVM LOUVER
 HEAD AND SILL DETAIL

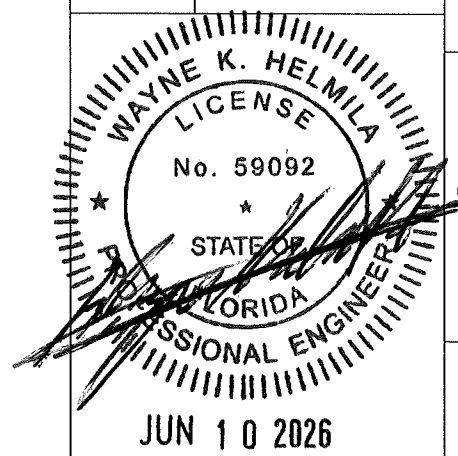

RICE
 ENGINEERING
 105 School Creek Trail
 Luxemburg, WI 54217
 Phone: (920) 617-1042
 Fax: (920) 617-1100
 www.rice-inc.com

Florida Firm No: F-01000005061
 Certificate of Authorization: #9090
 Wayne K. Helmila
 Registration No: 59092

GROUT FILLED CMU
(BY OTHERS)

WOOD / STEEL 16GA.
STEEL A-36 / CONCRETE
(BY OTHERS)

PRODUCT REVISED
as complying with the Florida
Building Code
NOA-No. 26-0518.09
Expiration Date 08/30/2028
By *[Signature]*
Miami-Dade Product Control

DWN BY: fcoartinas
CHK BY: BDennis
DATE: 4/30/2026
SCALE: NTS
SHEET: 4 OF 12
DWG. NO. 1605WDVM
REV B

PRIVATE & CONFIDENTIAL
DO NOT REPRODUCE WITHOUT THE PERMISSION OF
Nailor Industries of Texas, Inc.
Houston, TX 77039
4714 Winfield Road
TEL: 281-590-1172 FAX: 281-590-3086
www.nailor.com

TITLE:
1605WDVM LOUVER
SKINNY WALL APPLICATION
HEAD AND SILL DETAIL

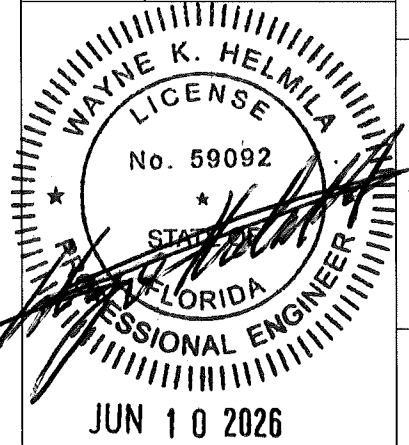

RICE
ENGINEERING
105 School Creek Trail
Luxemburg, WI 54217
Phone: (920) 617-1042
Fax: (920) 617-1100
www.rice-inc.com

Florida Firm No: F-0100005061
Certificate of Authorization: #9090
Wayne K. Helmila
Registration No: 59092

REV. B - UPDATED FASTENER NOTE TO
REFLECT CHANGES TO FASTENER TABLES
- CMU DETAIL UPDATED PER CALCUTATIONS

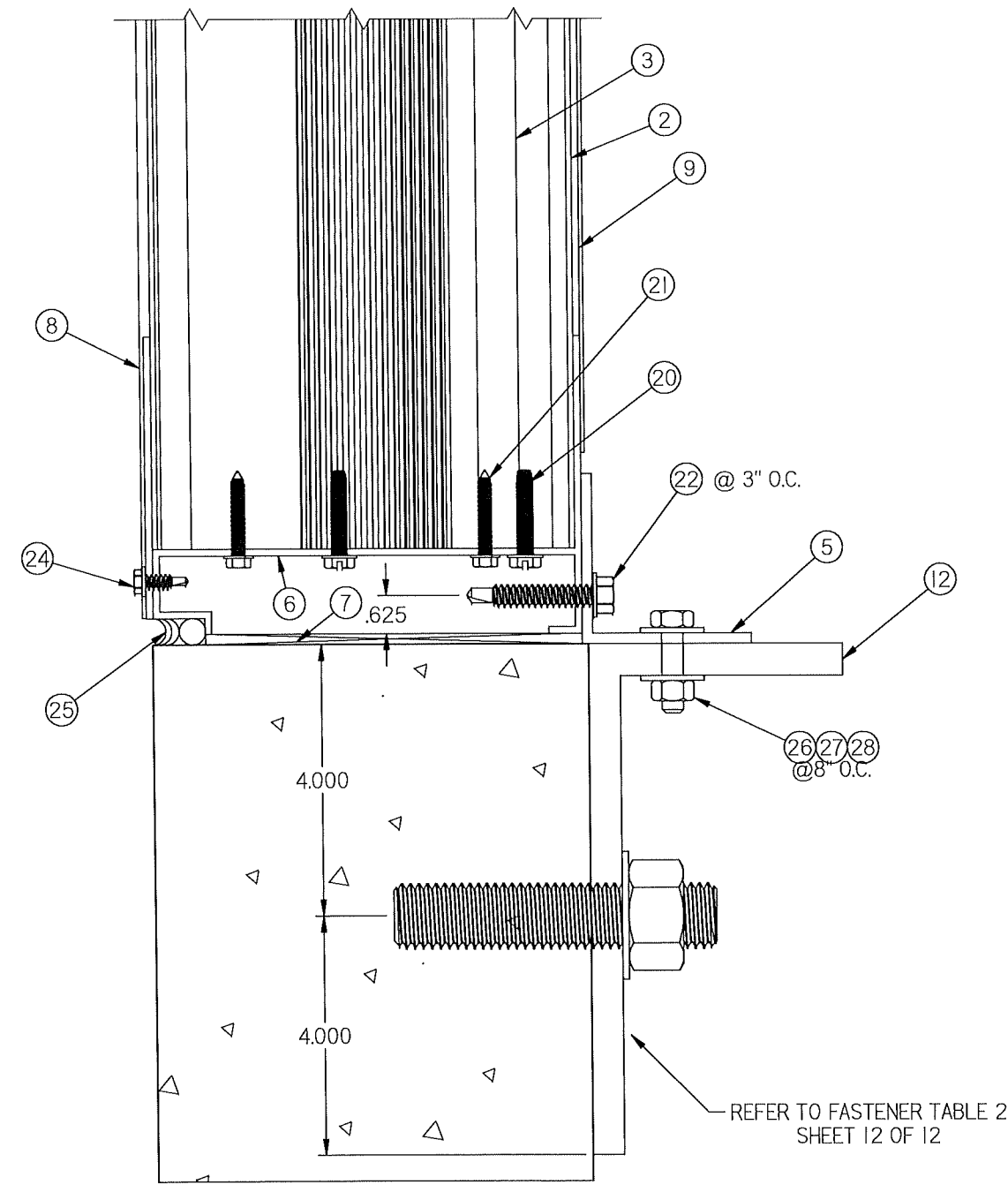

SILL DETAIL
2A SKINNY WALL
4/12

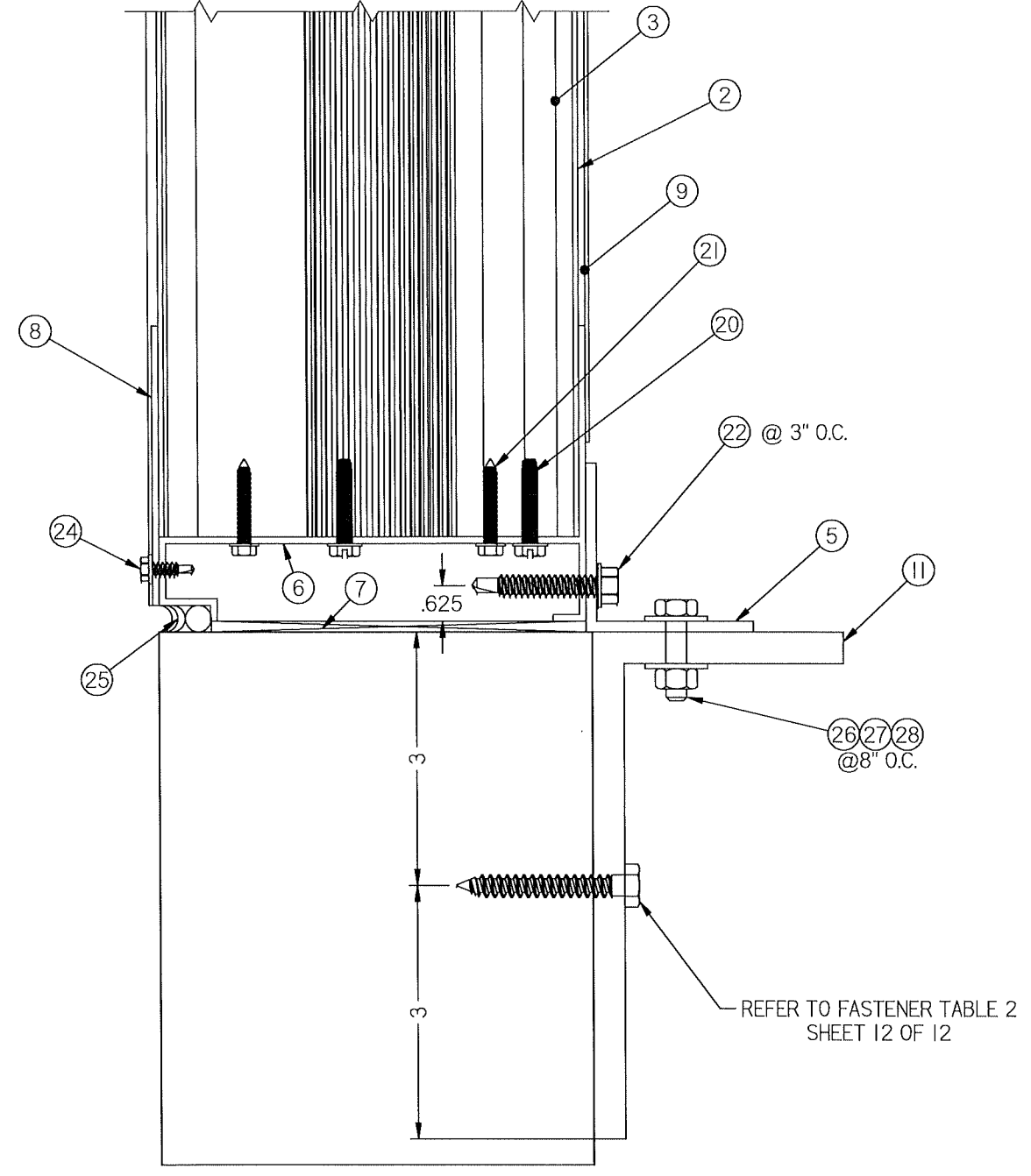

SILL DETAIL
2B SKINNY WALL
4/12

GROUT FILLED CMU
(BY OTHERS)

WOOD / STEEL 16G.A.
STEEL A-36 / CONCRETE
(BY OTHERS)

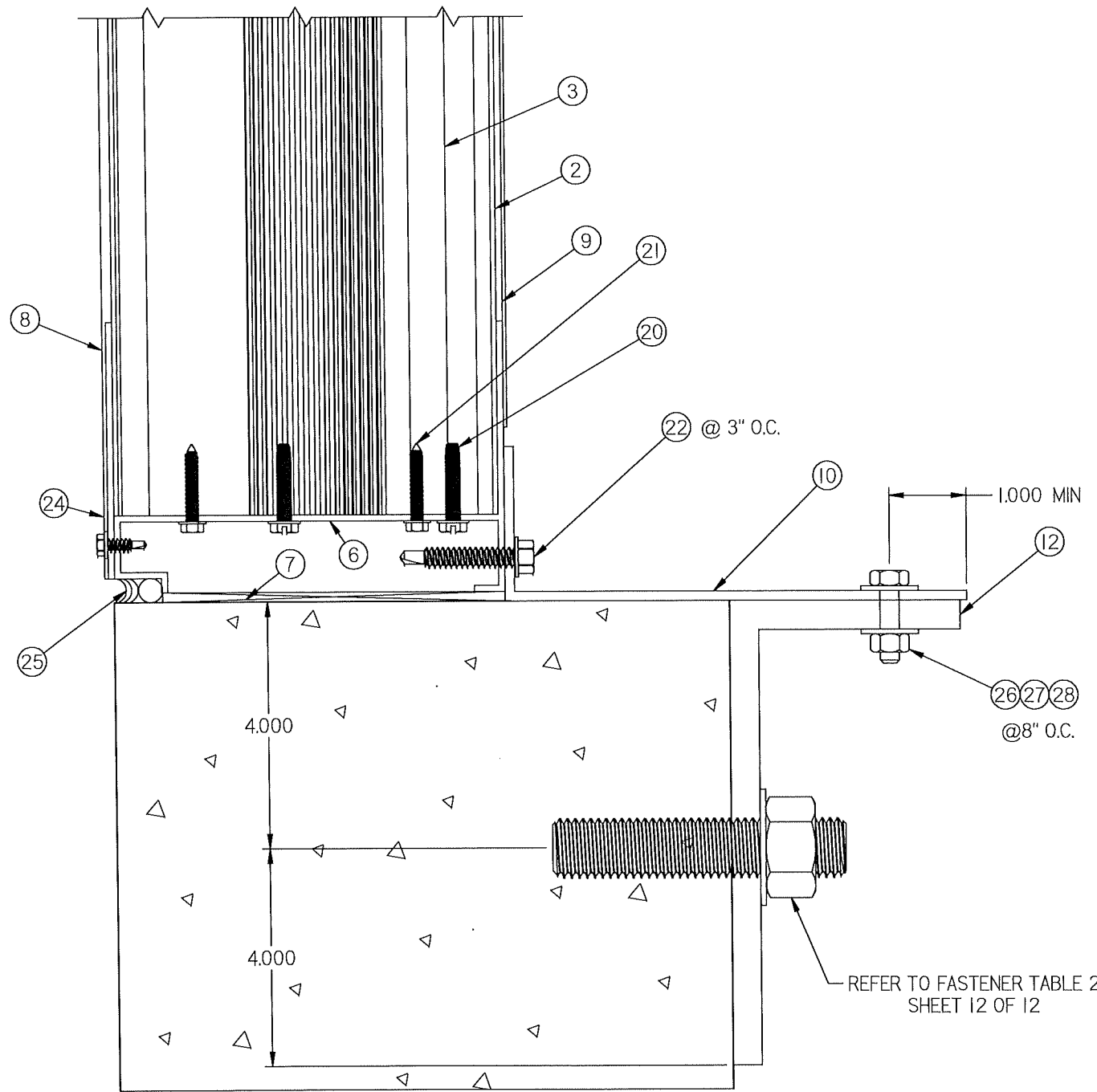

2A
SILL DETAIL
SKINNY WALL
5/12

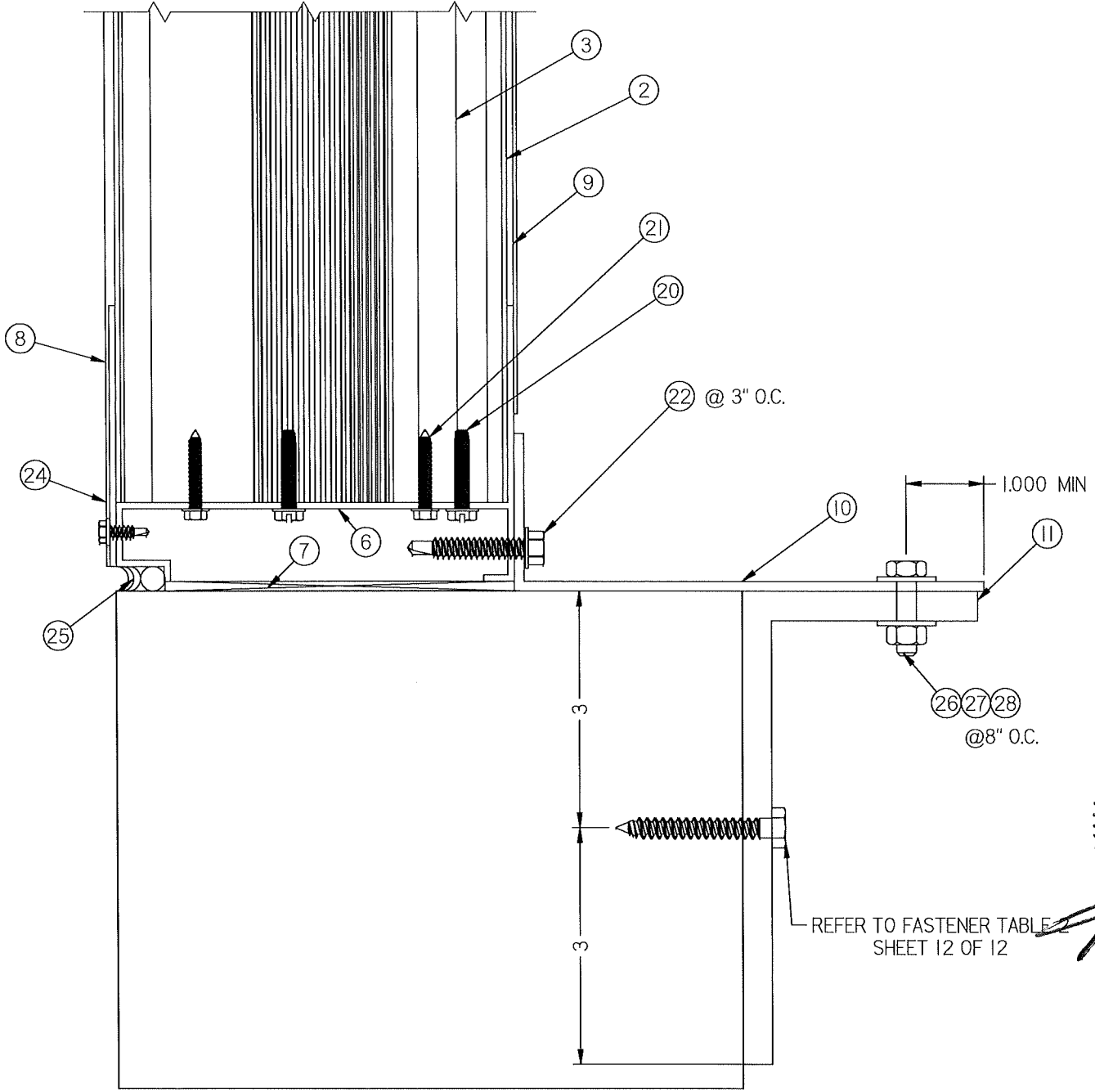

2B
SILL DETAIL
SKINNY WALL
5/12

PRODUCT REVISED
as complying with the Florida
Building Code
NOA-No. 26-0518.09
Expiration Date 08/30/2028
By *[Signature]*
Miami-Dade Product Control

DWN BY: fcortinas	CHK BY: BDennis
DATE: 4/30/2026	SCALE: NTS
SHEET: 5 OF 12	
DWG. NO. 1605WDVM	REV B

PRIVATE & CONFIDENTIAL
DO NOT REPRODUCE WITHOUT THE PERMISSION OF
Nailor Industries of Texas, Inc.
Houston, TX 77039
4714 Winfield Road
TEL: 281-590-1172 FAX: 281-590-3086
www.nailor.com

TITLE:
1605WDVM LOUVER
SKINNY WALL APPLICATION
HEAD AND SILL DETAIL
CONT.

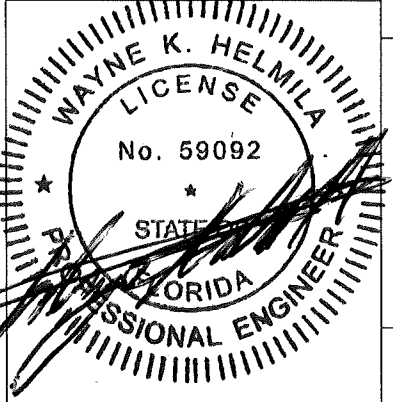

JUN 10 2026

RICE
ENGINEERING
105 School Creek Trail
Luxemburg, WI 54217
Phone: (920) 617-1042
Fax: (920) 617-1100
www.rice-inc.com
Florida Firm No: F-01000005061
Certificate of Authorization: #9090
Wayne K. Helmila
Registration No: 59092

REV. B- ADDED PAGE TO SHOW ALTERNATE
INSTALLATION FOR THICKER SUBSTRATES.

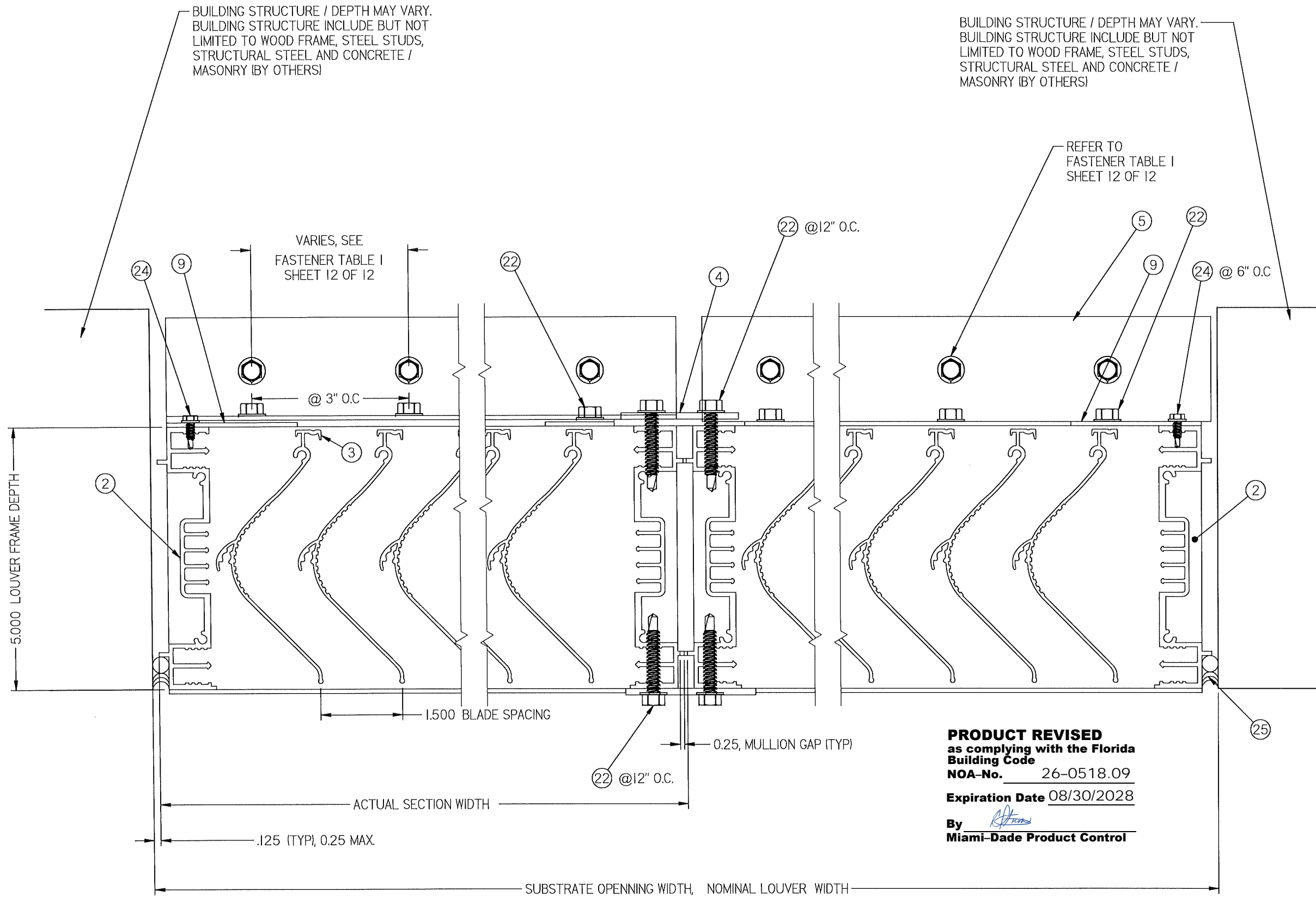

BUILDING STRUCTURE / DEPTH MAY VARY.
 BUILDING STRUCTURE INCLUDE BUT NOT
 LIMITED TO WOOD FRAME, STEEL STUDS,
 STRUCTURAL STEEL AND CONCRETE /
 MASONRY (BY OTHERS)

BUILDING STRUCTURE / DEPTH MAY VARY.
 BUILDING STRUCTURE INCLUDE BUT NOT
 LIMITED TO WOOD FRAME, STEEL STUDS,
 STRUCTURAL STEEL AND CONCRETE /
 MASONRY (BY OTHERS)

VARIES, SEE
 FASTENER TABLE I
 SHEET 12 OF 12

REFER TO
 FASTENER TABLE I
 SHEET 12 OF 12

PRODUCT REVISED
 as complying with the Florida
 Building Code
 NOA-No. 26-0518.09
 Expiration Date 08/30/2028
 By *[Signature]*
 Miami-Dade Product Control

3 JAMB DETAIL
 6/12

4 MULLION DETAIL
 6/12

3 JAMB DETAIL OPP.
 6/12

PRIVATE & CONFIDENTIAL
 DO NOT REPRODUCE WITHOUT THE PERMISSION OF
Nailor Industries of Texas, Inc.
 Houston, TX 77039
 4714 Winfield Road
 TEL: 281-590-1172 FAX: 281-590-3086
 www.nailor.com

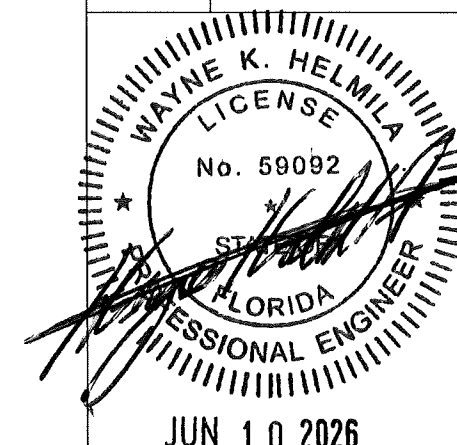

RICE
 ENGINEERING
 105 School Creek Trail
 Luxemburg, WI 54217
 Phone: (920) 617-1042
 Fax: (920) 617-1100
 www.rice-inc.com

Florida Firm No: F-0100005061
 Certificate of Authorization: #9090
 Wayne K. Helmila
 Registration No: 59092

REVISIONS:
 REV B: ADDED NOTE FOR ANGLE
 INSTALLATION O.C.
 - UPDATED PAGE NUMBERS

DWN BY: fcortinas	CHK BY: BDennis
DATE: 4/30/2026	SCALE: NTS
SHEET: 6 OF 12	
DWG. NO.	REV
I605WDVM	B

TITLE:
 I605WDVM LOUVER
 JAMB AND MULLION DETAIL

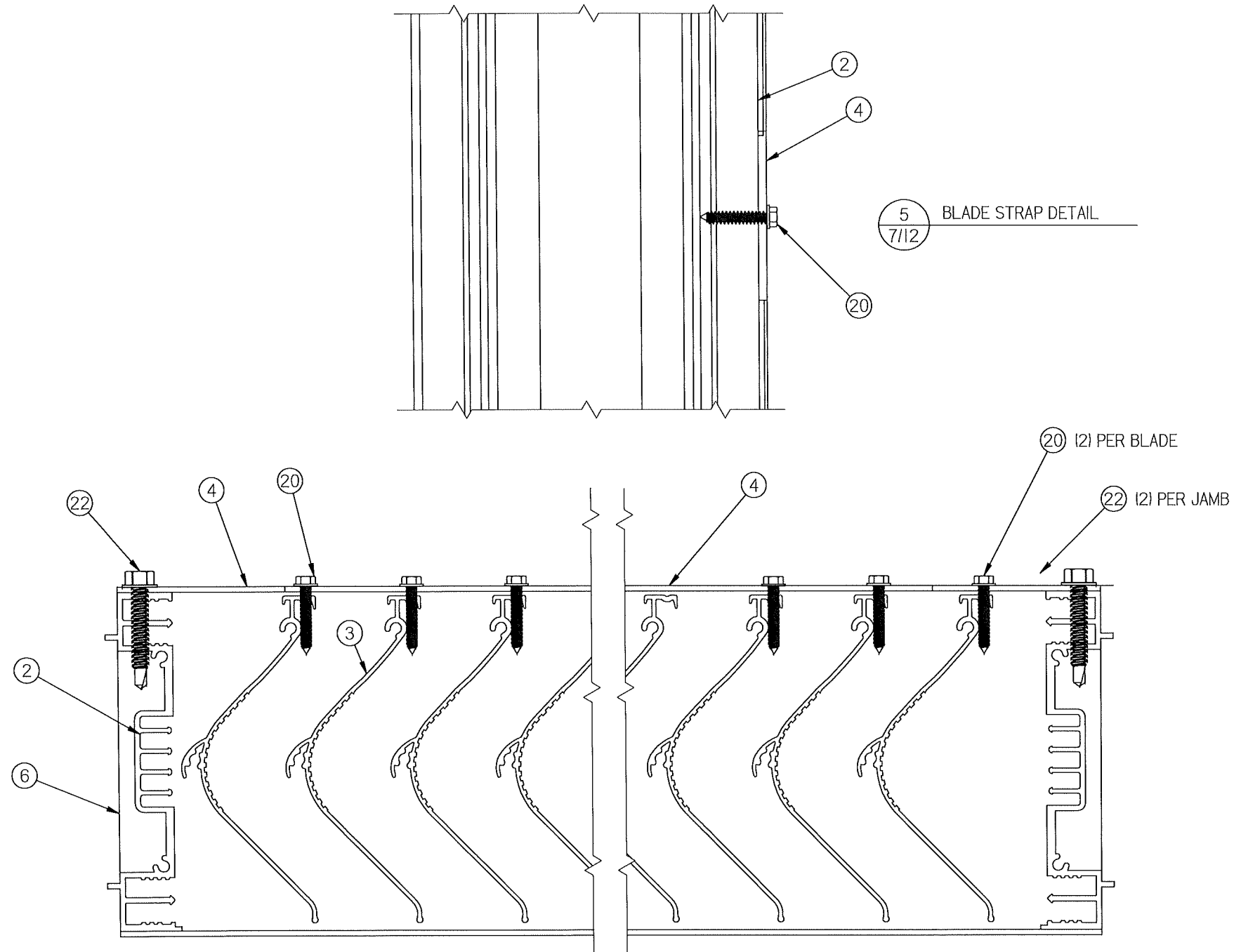

6
7/12
BLADE STRAP
AT JAMB DETAIL

6
7/12
BLADE STRAP
AT JAMB DETAIL OPP.

DWN BY: fcortinas	CHK BY: BDennis
DATE: 4/30/2026	SCALE: NTS
SHEET: 7 OF 12	
DWG. NO.	REV
1605WDVM	B

PRIVATE & CONFIDENTIAL
DO NOT REPRODUCE WITHOUT THE PERMISSION OF
Nailor Industries of Texas, Inc.
Houston, TX 77039
4714 Winfield Road
TEL: 281-590-1172 FAX: 281-590-3086
www.nailor.com

TITLE:
1605WDVM LOUVER
BLADE STRAP DETAIL

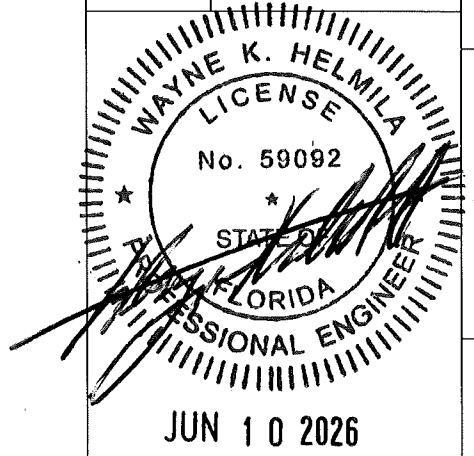

PRODUCT REVISED
as complying with the Florida
Building Code
NOA-No. 26-0518.09
Expiration Date 08/30/2028
By *[Signature]*
Miami-Dade Product Control

RICE
ENGINEERING
105 School Creek Trail
Luxemburg, WI 54217
Phone: (920) 617-1042
Fax: (920) 617-1100
www.rice-inc.com
Florida Firm No: F-01000005061
Certificate of Authorization: #9090
Wayne K. Helmila
Registration No: 59092

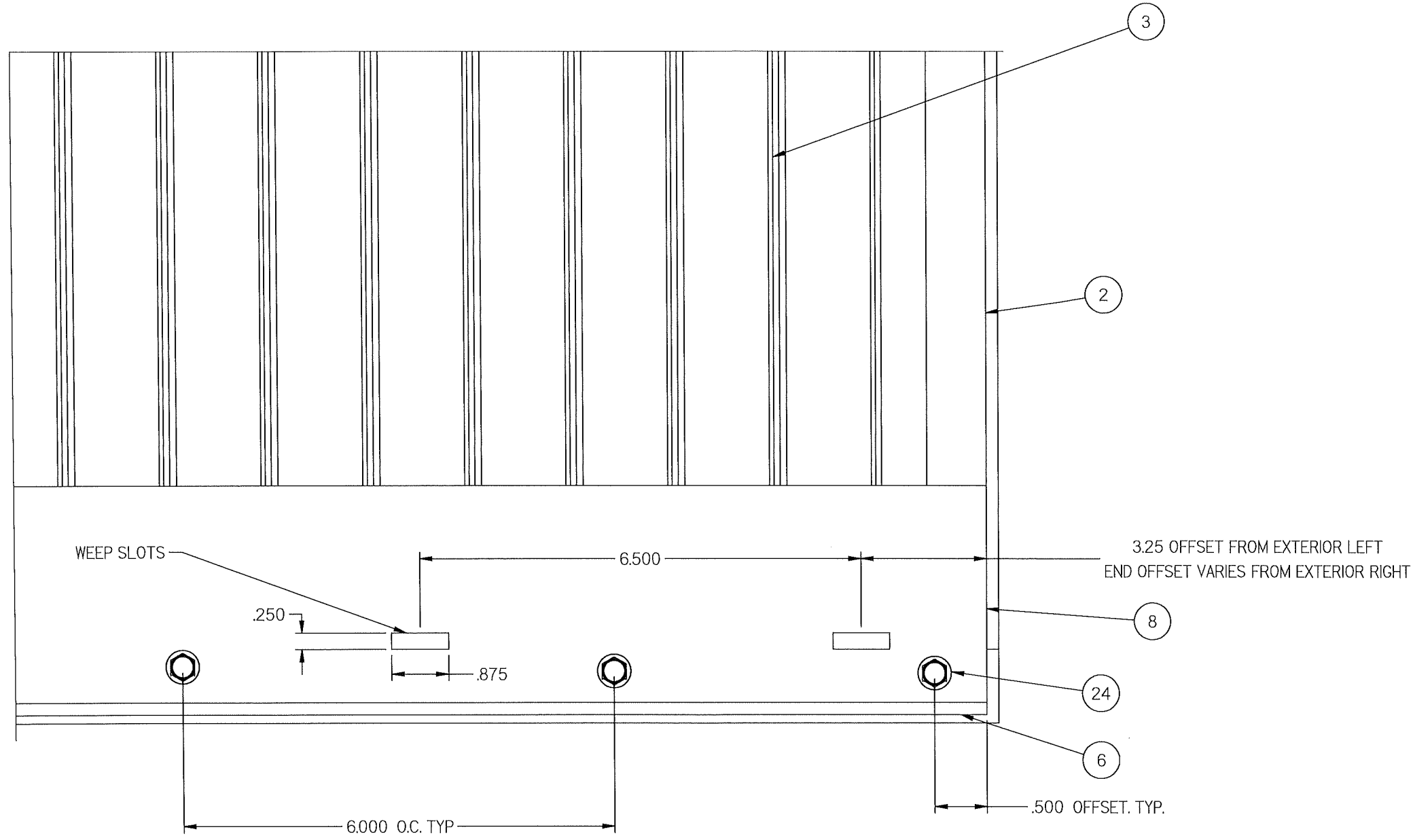

7 BAFFLE / WEEP DETAIL
8/12

PRODUCT REVISED
as complying with the Florida
Building Code
NOA-No. 26-0518.09
Expiration Date 08/30/2028
By *[Signature]*
Miami-Dade Product Control

REV. B - UPDATED PAGE NUMBERS
- ADDED SCREW AND BAFFLE

PRIVATE & CONFIDENTIAL
DO NOT REPRODUCE WITHOUT THE PERMISSION OF
Nailor Industries of Texas, Inc.
Houston, TX 77039
4714 Winfield Road
www.nailor.com TEL: 281-590-1172 FAX: 281-590-3086

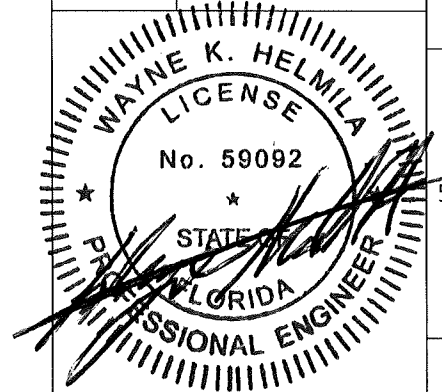

JUN 10 2026

RICE
ENGINEERING

105 School Creek Trail
Luxemburg, WI 54217
Phone: (920) 617-1042
Fax: (920) 617-1100
www.rice-inc.com

Florida Firm No: F-01000005061
Certificate of Authorization: #9090
Wayne K. Helmila
Registration No: 59092

DWN BY: fcoortinas
CHK BY: BDennis
DATE: 4/30/2026
SCALE: NTS
SHEET: 8 OF 12
DWG. NO. 1605WDVM
REV B

TITLE:
1605WDVM LOUVER
BAFFLE / WEEP DETAIL

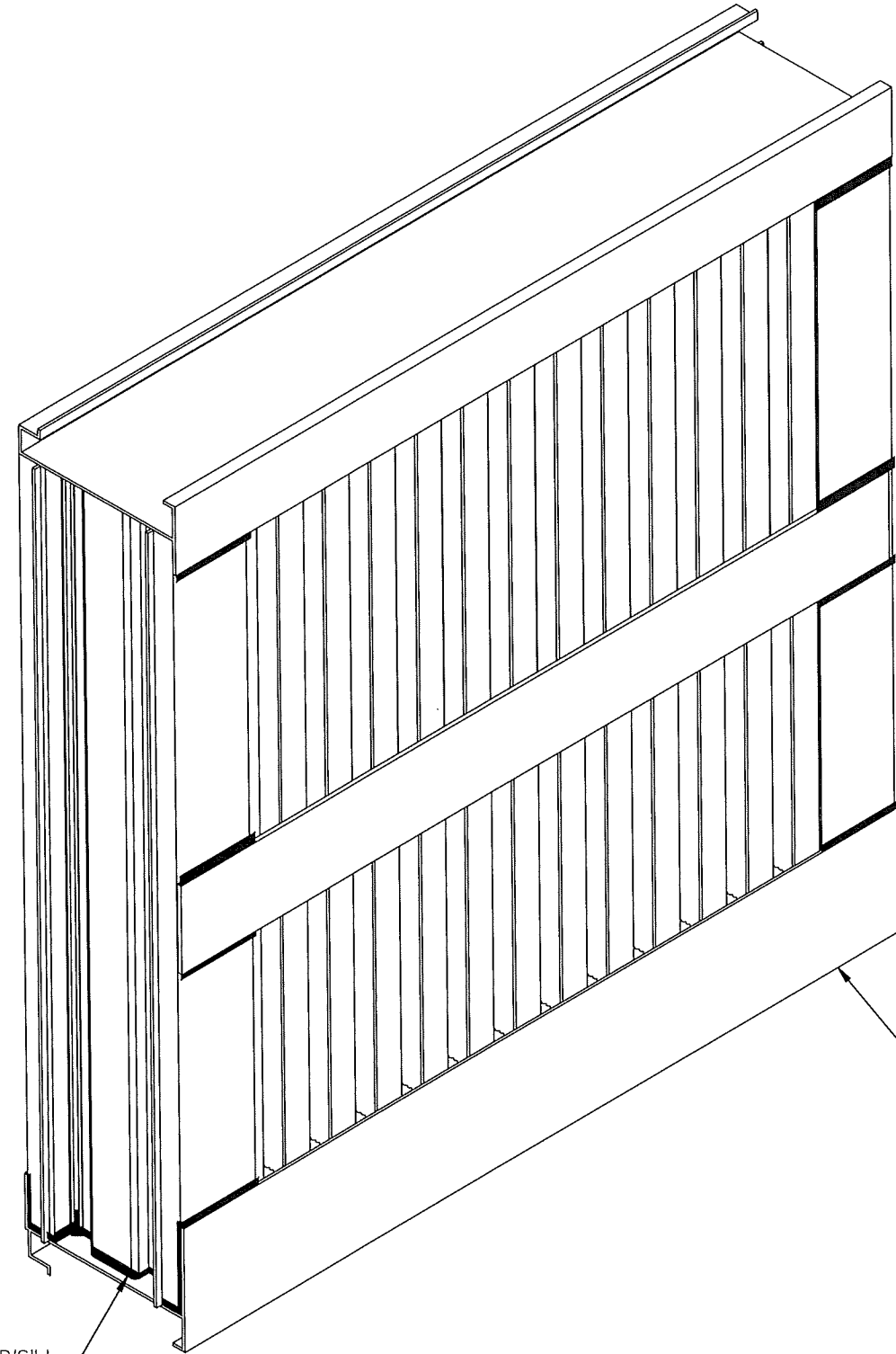

STANDARD SEAL AT JAMB/SILL CONNECTION
(MASTERWELD 626 OR EQUIVALENT)

SEAL ALL FASTENERS UNDER SILL
(MASTERWELD 626 OR EQUIVALENT)

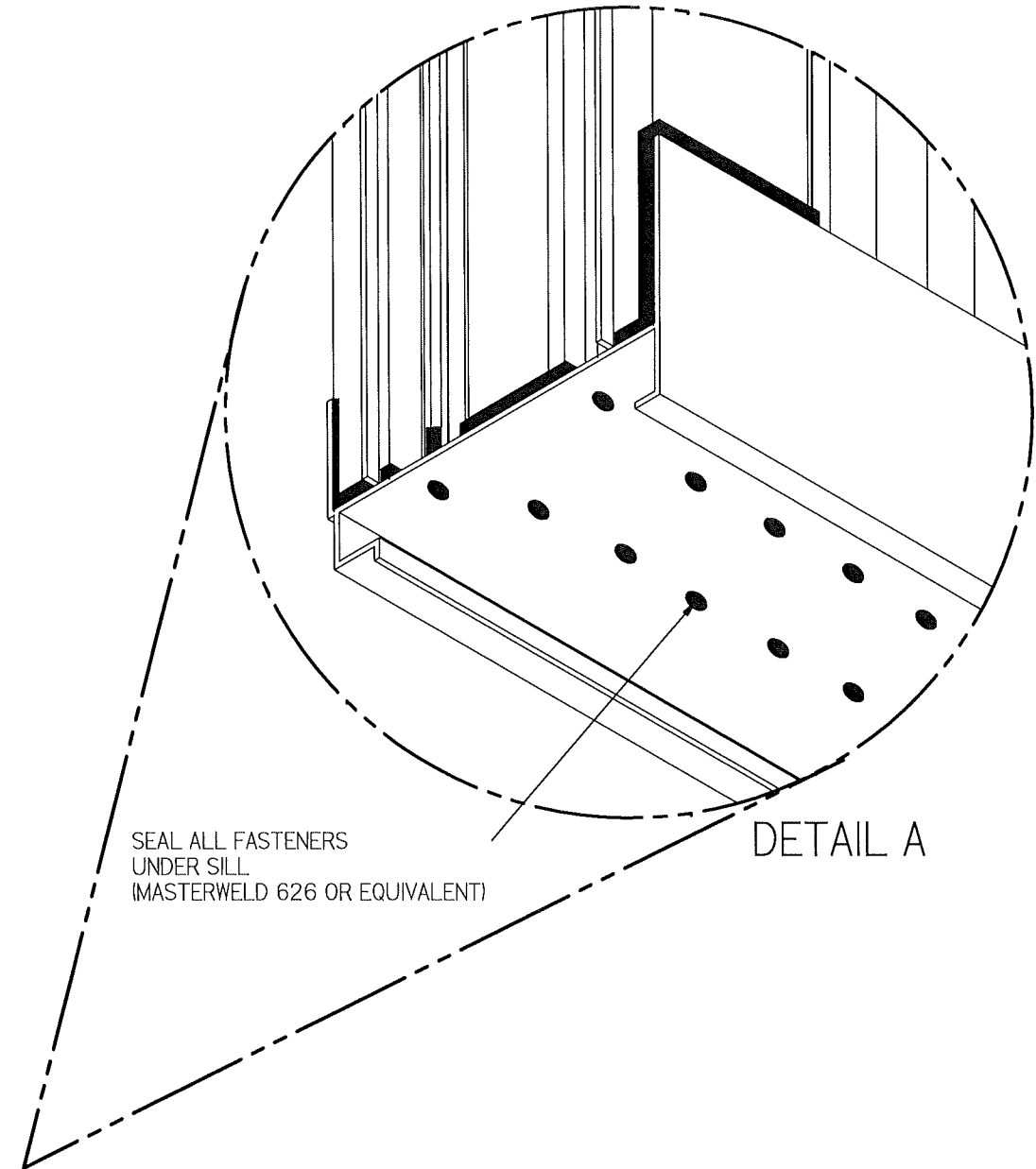

SEAL ALL FASTENERS UNDER SILL
(MASTERWELD 626 OR EQUIVALENT)

DETAIL A

PRIVATE & CONFIDENTIAL
DO NOT REPRODUCE WITHOUT THE PERMISSION OF
Nailor Industries of Texas, Inc.
4714 Winfield Road Houston, TX 77039
www.nailor.com TEL: 281-590-1172 FAX: 281-590-3086

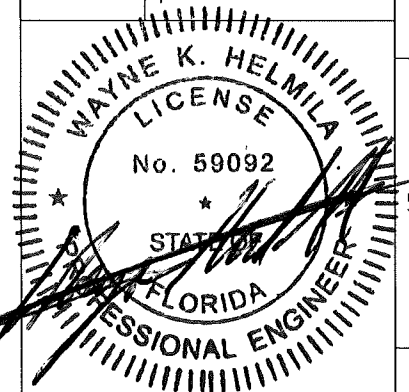

JUN 10 2026

RICE
ENGINEERING

105 School Creek Trail
Luxemburg, WI 54217
Phone: (920) 617-1042
Fax: (920) 617-1100
www.rice-inc.com

Florida Firm No: F-0100005061
Certificate of Authorization: #9090
Wayne K. Helmila
Registration No: 59092

DWN BY: fcortinas
DATE: 4/30/2026
CHK BY: BDennis
SCALE: NTS

TITLE:
1605WDVM LOUVER
SEALANT DETAIL

SHEET: 9 OF 12

DWG. NO. **1605WDVM**
REV B

PRODUCT REVISED
as complying with the Florida
Building Code
NOA-No. 26-0518.09
Expiration Date 08/30/2028
By *[Signature]*
Miami-Dade Product Control

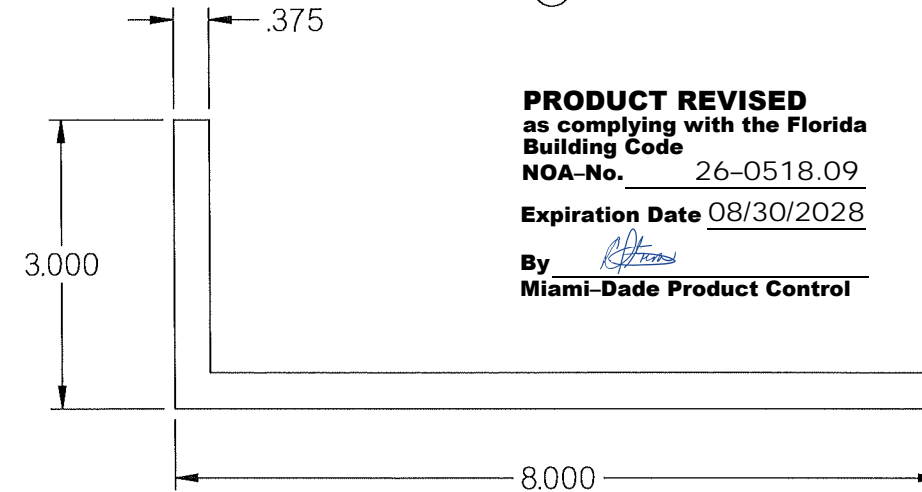
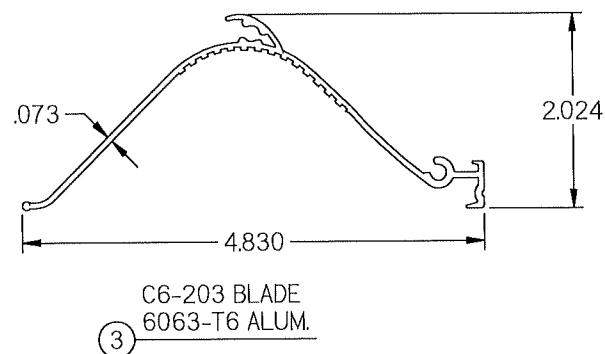
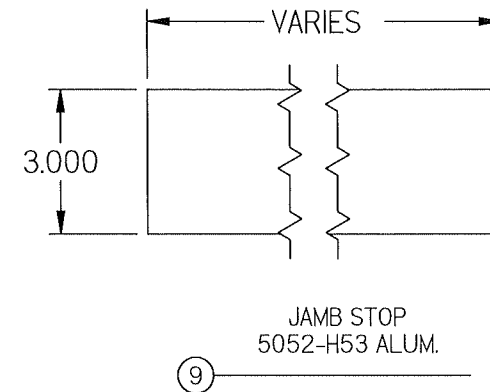
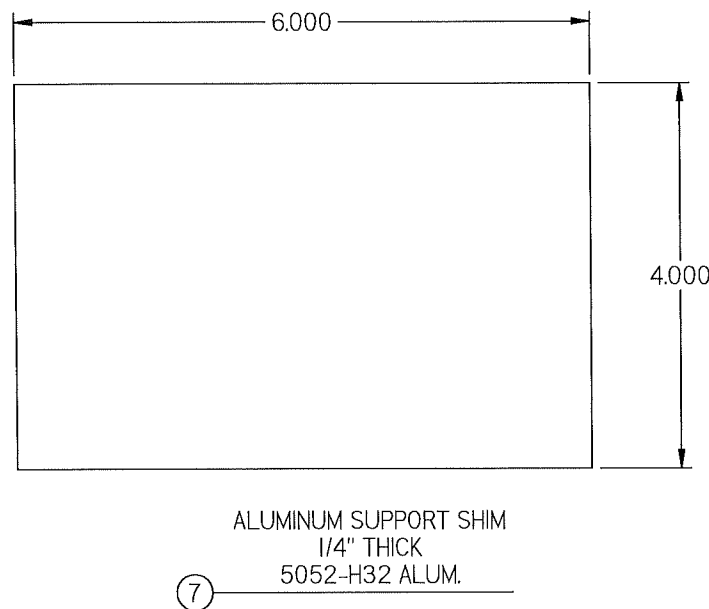
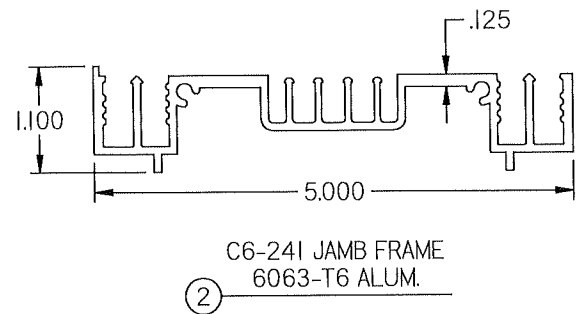
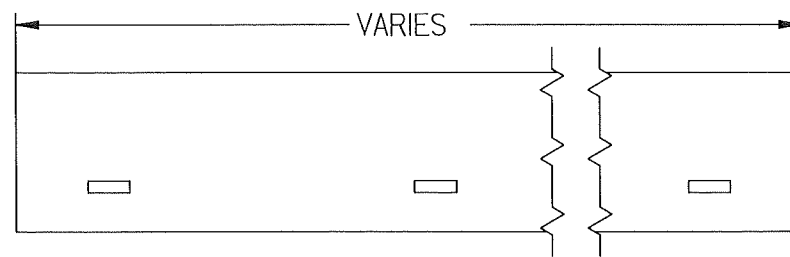
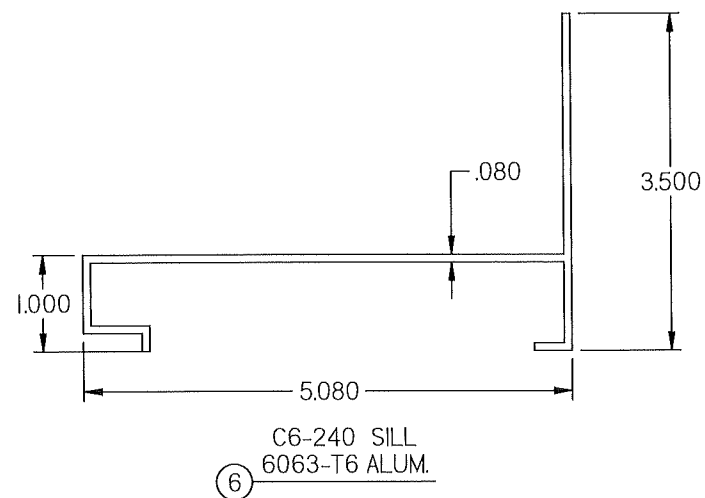
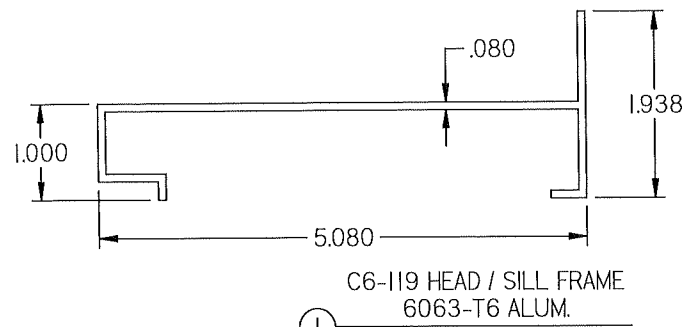

PRODUCT REVISED
as complying with the Florida
Building Code
NOA-No. 26-0518.09
Expiration Date 08/30/2028
By *[Signature]*
Miami-Dade Product Control

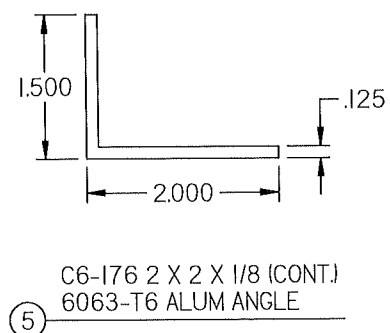
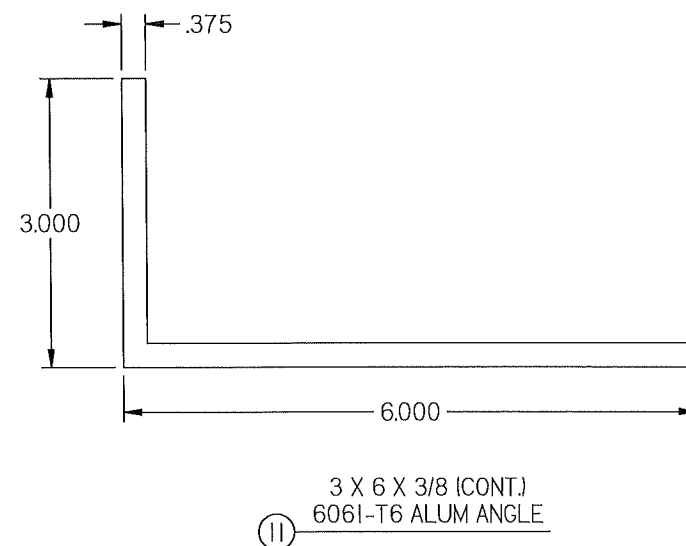
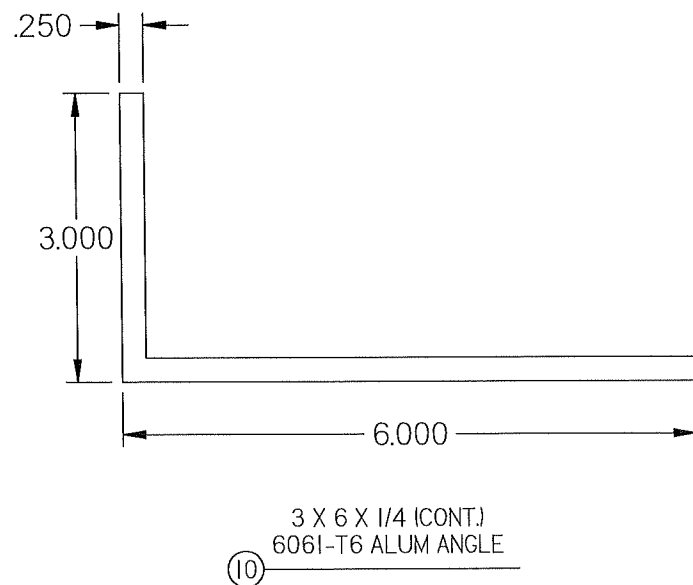
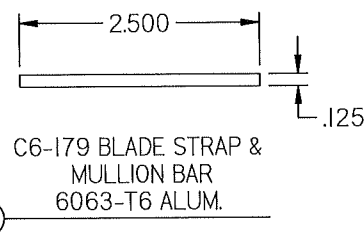

REV. B- UPDATED PAGE NUMBER
- UPDATED SILL, JAMB,
- ADDED BAFFLE, 3 X 8 X 3/8 ANGLE
- ADDED 3 X 6 X 1/4 ANGLE
- ADDED JAMB STOPS

DWN BY: fcortinas	CHK BY: BDennis
DATE: 4/30/2026	SCALE: NTS
SHEET: 100F 12	
DWG. NO.	REV B
1605WDVM	

PRIVATE & CONFIDENTIAL
DO NOT REPRODUCE WITHOUT THE PERMISSION OF
Nailor Industries of Texas, Inc.
Houston, TX 77039
4714 Winfield Road
TEL: 281-590-1172 FAX: 281-590-3086
www.nailor.com

TITLE: 1605WDVM LOUVER
PART PROFILES

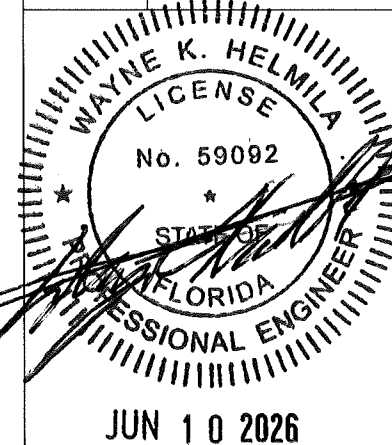

RICE
ENGINEERING
105 School Creek Trail
Luxemburg, WI 54217
Phone: (920) 617-1042
Fax: (920) 617-1100
www.rice-inc.com
Florida Firm No: F-01000005061
Certificate of Authorization: #9090
Wayne K. Helmila
Registration No: 59092

BILL OF MATERIALS

ITEM	INTERNAL ID	DESCRIPTION	MATERIAL	NOTES
1	C6-119	HEAD / SILL FRAME	6063-T6	ONLY AT HEAD
2	C6-241	JAMB FRAME	6063-T6	
3	C6-203	BLADE	6063-T6	1.5" CENTERS/SPACING
4	C6-179	BLADE STRAP / MULLION BAR	6063-T6	REQUIRED IF SECTION HEIGHT IS 60.0"
5	C6-160	2 X 2 X 1/8 ANGLE (CONT.)	6063-T6	AT HEAD AND SILL ONLY
6	C6-240	SILL	6063-T6	ONLY AT SILL
7	-	ALUMINIUM SUPPORT SHIM	5052-H32	BY OTHERS , OPTIONAL, AS NEEDED
8	-	BAFFLE	5052-H32	FRONT DRAIN
9	-	JAMB STOP	5052-H32	SIZE VARIES AS NEEDED
10	-	6 x 3 x 1/4 ANGLE (CONT.)	6061-T6	USED FOR SKINNY WALL APPLICATIONS
11	-	6 X 3 X 3/8 ANGLE (CONT.)	6061-T6	USED IN SKINNY WALL APPLICATION
12	-	3 X 8 X 3/8 ANGLE (CONT.)	6061-T6	USED IN SKINNY WALL APPLICATION FOR CMU

20	C6-189	SCREW, MACHINE, HW, #10-24 X 1 1/2,	300 SERIES, SS CON. CW	2 @ BLADE ENDS, AND BLADE STRAP ONE PER BLADE
21	C6-192	SCREW, MACHINE, HEX, #10 X 1 1/2,	300 SERIES, SS CON. CW	2 @ FRAME CORNERS
22	C6-193	SCREWM METAL, HEX, #14 X 1 1/2,	300 SERIES, SS CON. CW	@ HEAD AND SILL, AND 2 AT BLADE STRAP AT JAMBS
24	C6-198	SCREW, MTL, HEX, #8 X 3/4,	300 SERIES, SS CON. CW	@ SILL AT BAFFLE AND JAMB STOPS @ 6" O.C.
25	-	SEALANT & BACKER ROD	VARIOUS	BY OTHERS
26	C6-181	1/4 NYLON INSERT LOCKNUT	STAINLESS	
27	C6-186	1/4 COMM'L FLAT WASHER	STAINLESS	
28	C6-187	1/4-20 X 1 HEX CAP SCREW 18-8 SS	STAINLESS	

GENERAL NOTES:

- DUE TO PASSING TAS-100A, THE LOUVER IS DESIGNED TO PREVENT WIND DRIVEN RAIN FROM PENETRATING THE SPACE BEHIND THE LOUVER. AS SUCH, THE LOUVER MAY BE INSTALLED IN A LOCATION WHERE THE SPACE/ROOM BEHIND THE LOUVER IS NOT DESIGNED TO DRAIN WATER PENETRATING INTO THE ROOM OR THE ROOM WILL HOUSE NON-WATER RESISTANT/ PROOF EQUIPMENT, COMPONENTS, OR SUPPLIES.
- THE MAXIMUM SINGLE SECTION SIZE IS 120 WIDE BY 72 HIGH OR 72 WIDE BY 120 HIGH. THE MAXIMUM OVERALL/ ASSEMBLED SIZE IS UNLIMITED WIDE BY USE OF MULTIPLE SECTIONS. SECTIONS/ ASSEMBLIES MAY BE STACKED VERTICALLY PROVIDED THERE IS SUITABLE STRUCTURAL SUPPORT (DESIGNED AND INSTALLED BY OTHERS) TO SUPPORT ALL LOADS TRANSFERRED FROM THE LOUVER HEAD AND / OR SILL MOUNTING ANGLES TO THE SUBSTRATE.
- GENERAL LOUVER CONSTRUCTION: HEAD, SILL, JAMBS, AND BLADES ARE EXTRUDED ALUMINIUM. BLADE SPACING IS 1.5 INCHES. BLADES ARE SECURED WITH (2) #10 X 1 1/2" MACHINE SCREWS PER BLADE END. HEAD IS SECURED TO THE JAMB WITH (2) #10 X 1 1/2" MACHINE SCREWS PER HEAD END, SILL IS SECURED TO JAMBS WITH (2) #10 X 1 1/2" MACHINE SCREWS PER SILL END. BLADE SUPPORT STRAP IS SECURED TO BLADES BY (2) SCREW PER BLADE AND SECURED TO JAMB BY (2) SCREWS AT STRAP END. BLADE SUPPORT STRAP IS REQUIRED IF ACTUAL LOUVER HEIGHT IS > 60 INCHES.
- INSTALLER TO PROVIDE SEPARATION OF DISSIMILAR MATERIALS AS REQUIRED. SEE ALUMINUM DESIGN MANUAL (CHAPTER F) FOR DETAILS.
- ALL ALUMINIUM, STAINLESS STEEL (SS), AND PLATED / COATED STEEL PARTS PROVIDED BY MANUFACTURER ARE INHERENTLY CORROSION RESISTANT OR HAVE A CORROSION RESISTANT COATING.
- STEEL / STAINLESS, STEEL / ALUMINIUM PARTS MAY BE MADE OUT OF ALTERNATE ALLOY THAT HAS EQUAL OR GREATER YIELD STRENGTH. PART DIMENSIONS ARE MINIMUMS UNLESS DEFINED OTHER WISE.
- THE INTERNAL ID# SHOWN ON PAGE 9 IS FOR FACTORY USE AND TRACKING PURPOSES ONLY AND MAY BE UPDATED AT ANY TIME. ANY UPDATES WILL NOT ALTER THE ITEM AS DESCRIBED HEREIN.

N:\Drawing\LOUVERS\AMCA\1605WDVM\1605WDVM.dft

CHK BY: BDennis
DWN BY: fcortinas
DATE: 4/30/2026
SCALE: NTS

SHEET: 11 OF 12

REV B
DWG. NO. 1605WDVM

PRIVATE & CONFIDENTIAL
DO NOT REPRODUCE WITHOUT THE PERMISSION OF
Nailor Industries of Texas, Inc.
Houston, TX 77039
4714 Winfield Road
TEL: 281-590-1172 FAX: 281-590-3086
www.nailor.com

TITLE:
1605WDVM LOUVER
BILL OF MATERIAL
GENERAL NOTES

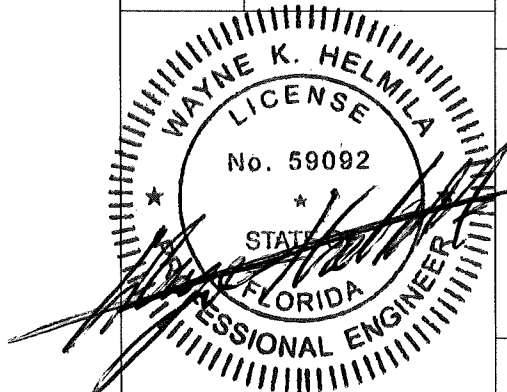

PRODUCT REVISED
as complying with the Florida
Building Code
NOA-No. 26-0518.09
Expiration Date 08/30/2028
By *[Signature]*
Miami-Dade Product Control

JUN 10 2026

RICE
ENGINEERING
105 School Creek Trail
Luxemburg, WI 54217
Phone: (920) 617-1042
Fax: (920) 617-1100
www.rice-inc.com
Florida Firm No: F-01000005061
Certificate of Authorization: #9090
Wayne K. Helmila
Registration No: 59092

REV B - UPDATED PAGE NO.
ADDED ITEM# 8- BAFFLE
ADDED ITEM# 9- JAMB STOP
ADDED ITEM #10- 6 X 3 X 1/4 ANGLE (CONT)
ADDED ITEM#11- 6 X 3 X 3/8 ANGLE (CONT)
ADDED ITEM # 12 -8 X 3 X 3/8 ANGLE (CONT)

TABLE 1: HEAD & SILL ANCHORS

Wood	Steel Stud	Steel	Concrete	CMU	Skinny Wall	Min.	Fastener Type	Diameter	# Rqd	O.C. Spacing	Edge	End	Embedment
X						SG 0.42	LAG BOLT (300 SERIES SS - COND. CW - Fy = 65 ksi)	1/4"	1	3-1/4"	2"		2-1/16
X						SG 0.42	LAG BOLT (300 SERIES SS - COND. CW - Fy = 65 ksi)	3/8"	1	3-3/4"	2"		2-1/16
	X					16 Ga.	Elco Bi-Flex Screws (300 Series SS, FY = 65 ksi)	1/4"	1	3"	2"		3 THREADS BEYOND SUBSTRATE
		X				A-36	Elco Bi-Flex Screws (300 Series SS, FY = 65 ksi)	1/4"	1	9"	2"		1/4"
		X				A-36	Elco Drill-Flex Drilling Screws (Cond. CW - Fy= 65ksi) Sealed w/ Liquid Prosoco	5/16"	1	12"	2"		1/4"
			X- Cracked 6" Deep			4 ksi	Hilti Kwik HUS-EZ SS 316	3/8"	1	12"	4"	4"	2-1/2

TABLE 2: SKINNY WALL ANCHORS

Wood	Steel Stud	Steel	Concrete	CMU	Skinny Wall	Min.	Fastener Type	Diameter	# Rqd	O.C. Spacing	Edge	End	Embedment
X					X	SG 0.42	LAG BOLT (300 SERIES SS - COND. CW - Fy = 65 ksi)	1/4"	1	3-3/4"	3"		2-3/16"
X					X	SG 0.42	LAG BOLT (300 SERIES SS - COND. CW - Fy = 65 ksi)	3/8"	1	5"	3"		2-3/16"
	X				X	16 Ga.	Elco Bi-Flex Drilling Screws (300 Series SS, FY = 65 ksi)	1/4"	1	1"	3"		3 THREADS BEYOND SUBSTRATE
		X			X	A-36	Elco Bi-Flex Drilling Screws (300 Series SS, FY = 65 ksi)	1/4"	1	7"	3"		1/4"
		X			X	A-36	Elco Drill-Flex Drilling Screws (Cond. CW - Fy= 65ksi) Sealed w/ Liquid Prosoco	5/16"	1	8"	3"		1/4"
			X- Cracked 6" Deep		X	4 ksi	HILTI KWIK BOLT TZ2 SS 304	3/8"	1	8"	3"	3"	2-1/2"
			X- Cracked 6" Deep		X	4 ksi	HILTI KWIK BOLT TZ2 SS 304	1/2"	1	10"	3"	3"	3"
				X-Grout Filled	X	2 ksi	HILTI HIT-Hy 270 Threaded Rod 316/304 SS	3/4"	1	8"	4"		6-3/4"

- NOTE 1: CONCRETE MASONRY (CMU) SHALL BE > THE FOLLOWING, 6" WIDE, CMU CONFORMING TO ASTM C-90 FILLED WITH 4,747 KSI GROUT.
- NOTE 2: CONCRETE MASONRY (CMU) SHALL BE > THE FOLLOWING, 6" WIDE, GRADE N, TYPE II, LIGHT-WEIGHT / MEDIUM-WEIGHT / NORMAL-WEIGHT CMU CONFORMING TO ASTM C-90. MORTAR MUST BE TYPE N. CMU STRENGTH = 2000 psi
- NOTE 3: CONCRETE, STEEL, WOOD, MASONRY, CURTAIN WALL, STOREFRONT, AND ALL OTHER BUILDING SUBSTRATES ARE DESIGNED BY OTHERS.
- NOTE 4: ENGINEER OF RECORD TO VERIFY THAT BUILDING SUBSTRATE CAN SUPPORT THE LOUVER REACTIONS.
- NOTE 5: THREAD PENETRATION LENGTH SIGNIFIES THE REQUIRED LENGTH OF THE THREADED PORTION OF THE FASTENER INTO THE WOOD SUBSTRATE PROVIDING FULL CONTACT WITH WOOD. LAG SCREW TIP CANNOT BE CONSIDERED PART OF THE TREADED PORTION FO THE SCREW. LAG SCREWS ARE NOT TO BE INSTALLED AT WOOD JOINTS / SPICES WHERE THE LAG SCREW COULD FALL BETWEEN MEMBERS.
- NOTE 6: STEEL STUDS TO BE 16 GA. FY= 33ksi MIN.

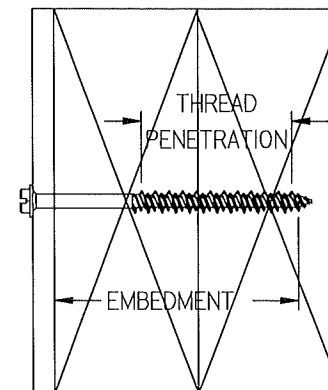

PRODUCT REVISED
 as complying with the Florida
 Building Code
 NOA-No. 26-0518.09
 Expiration Date 08/30/2028
 By *[Signature]*
 Miami-Dade Product Control

REVISIONS:
 REV B: UPDATED FASTENER
 SCHEDULE (2 TABLES).

DWN BY: fcortinas
 CHK BY: BDennis
 DATE: 4/30/2026
 SCALE: NTS

SHEET: 120F 12
 DWG. NO. 1605WDVM
 REV B

PRIVATE & CONFIDENTIAL
 DO NOT REPRODUCE WITHOUT THE PERMISSION OF
Nailor Industries of Texas, Inc.
 Houston, TX 77039
 4714 Winfield Road
 TEL: 281-590-1172 FAX: 281-590-3086
 www.nailor.com

TITLE: 1605WDVM LOUVER
 FASTENER SCHEDULE

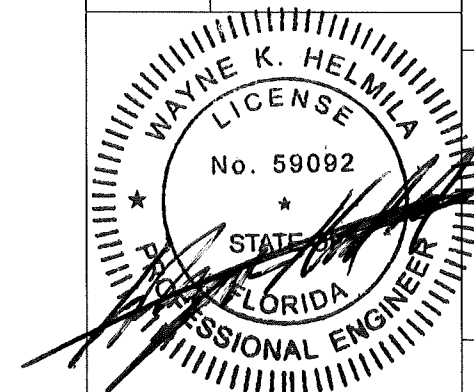

JUN 10 2026

RICE
 ENGINEERING
 105 School Creek Trail
 Luxemburg, WI 54217
 Phone: (920) 617-1042
 Fax: (920) 617-1100
 www.rice-inc.com
 Florida Firm No: F-01000005061
 Certificate of Authorization: #9090
 Wayne K. Helmila
 Registration No: 59092