

MEMORANDUM

Agenda Item No. 8(G)(1)

TO: Honorable Chairman Jose "Pepe" Diaz
and Members, Board of County Commissioners

DATE: March 15, 2022

FROM: Geri Bonzon-Keenan
County Attorney

SUBJECT: Resolution approving Fifth Amendment between Miami-Dade County, City of Miami Beach, and Miami Beach Redevelopment Agency to Interlocal Cooperation Agreement dated November 16, 1993; and authorizing County Mayor to execute the Fifth Amendment and exercise all provisions contained therein

The accompanying resolution was prepared by the Office of Management and Budget and placed on the agenda at the request of Prime Sponsor Commissioner Eileen Higgins.



Geri Bonzon-Keenan
County Attorney

GBK/jp

Memorandum



Date: March 15, 2022

To: Honorable Chairman Jose “Pepe” Diaz
and Members, Board of County Commissioners

From: Daniella Levine Cava 
Mayor

Subject: Fifth Amendment to the Miami Beach Redevelopment Agency’s Interlocal Cooperation Agreement

Recommendation

It is recommended that the Board of County Commissioners (Board) approve the Fifth Amendment to the Interlocal Cooperation Agreement (Fifth Amendment) among Miami-Dade County (County), City of Miami Beach (City) and the Miami Beach Redevelopment Agency (Agency) related to the City Center/Historic Convention Center Village Redevelopment and Revitalization Area (Area).

Scope of Agenda Item

The Area lies within County Commission District 5, which is represented by Commissioner Eileen Higgins.

Fiscal Impact/Funding Source

The Agency’s revenue source is tax increment financing (TIF), which is generated through the incremental growth of ad valorem revenues beyond an established base year, as defined in Section 163.387, Florida Statutes. The City will receive a \$27.1 million reimbursement from the Agency to be used to fund the settlement agreement with Clark Construction Group LLC (Clark) for the Convention Center Project (Project).

Track Record/Monitor

Staff from the Office of Management and Budget will monitor the agreement.

Delegation of Authority

The County Mayor or County Mayor’s designee will have the authority to execute the Fifth Amendment, attached as Exhibit B to the resolution.

Background

On January 26, 1993, the Board adopted Resolution No. R-14-93, which, among other things, (i) found the area to be a blighted area within the meaning of Part III of Chapter 163 of the Florida Statutes (Act) and (ii) delegated to the City the power to create the Agency, pursuant to the Act. On March 30, 1993, the Board adopted the Agency’s Community Redevelopment Plan (Plan) and approved an Interlocal Cooperation Agreement (Interlocal) among the County and City when it adopted Resolution No. R-317-93. The Interlocal required the Agency to submit an annual budget for County approval. On April 27, 1993, the Board adopted Ordinance No. 93-28 that created the trust fund. On July 27, 2004, the Board adopted Resolution No. R-958-04, approving the First Amendment to the Interlocal Agreement, which allowed the Agency to refund certain bonds and provided for an administrative fee.

On December 16, 2014, the Board approved Resolution No. R-1110-14, approving an amendment to the Miami Beach City Center/Historic Convention Village Redevelopment Plan to extend the life of the Agency until 2044, and approving the Third Amendment to the Interlocal Cooperation Agreement, which among other things allowed the Agency to issue \$430 million in bonds to refund existing debt, partially fund the Miami Beach Convention Center renovations and delineated the annual administrative and operating expenditures for the Agency. Additionally, the Board adopted Ordinance No. 14-133, obligating the County to fund the Trust Fund until March 31, 2044, or until all debt service for the Convention Center has been retired.

On June 19, 2018, through Resolution No. R-644-18, the Board approved a Fourth Amendment, which, among other things, allowed the Agency to fund repairs to the Convention Center as a result of a storm, provided additional funding for the Lincoln Road project and provides a refund to the County and City that includes a set aside of \$1.5 million each for beach renourishment through 2023. All other funding was set aside for prepayment of outstanding debt. At the time the Fourth Amendment was approved, it was estimated that the debt would have been retired in FY 2026-27.

On January 31, 2020, Clark filed a lawsuit against the City and Hill International Inc. (Hill) the City’s owner’s representative for the Project. The complaint filed by Clark seeks that Clark is entitled to: (1) significant time extensions, release of retainage and payment for work allegedly completed and within the scope of the contract; (2) damages for breach of contract; and (3) damages for Breach of Covenant of Good Faith and Fair Dealing. After several attempts to reach an agreement through mediation failed, the case was set for trial on August 30, 2021. After commencement of the trial, the court ordered the parties back to meditation. The parties were unable to reach an agreement through the mediation, but the court agreed to a recess of the trial so the parties could continue negotiations. On September 13, 2021, the parties announced to the court that a tentative agreement had been reached, pending drafting the settlement and approval of the City. On September 30, 2021, the City adopted Resolution No. 2021-31870 approving a settlement agreement between Clark, Hill, and the City (Attachment A). Additional details on the Project history, litigation and settlement are also included in Attachment A. The settlement requires (1) that the City release the retainage of \$6.4 million to Clark for work previously performed; (2) approves the payment of \$9.090 million held by the City for liquidated damages; and (3) approves an additional amount of \$18.010 million to Clark that includes extra work and change orders, Clark’s claims for additional general conditions, and subcontractor impact claims. The Fifth Amendment allows the Agency to disburse to the City \$27.1 million to fund the settlement agreement with Clark. Additionally, the Fifth Amendment clarifies that the County’s portion of the beach renourishment funds (\$1.5 million), outlined in the Fourth Amendment, can be used for beach renourishment activities at beaches in the County. Currently the trust fund balance is approximately \$31 million. Should the Board approve the Fifth Amendment (which is the disbursement of the \$27.1 million), it is estimated that the convention center bonds can be retired in FY 2031-32.

Attachment A – City Resolution No. 2021-31870

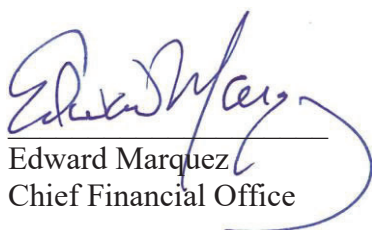

Edward Marquez
Chief Financial Office

RESOLUTION NO. 2021-31870

A RESOLUTION OF THE MAYOR AND CITY COMMISSION OF THE CITY OF MIAMI BEACH, FLORIDA, APPROVING THE SETTLEMENT AGREEMENT BETWEEN CLARK CONSTRUCTION GROUP, LLC ("CLARK"), HILL INTERNATIONAL INC. ("HILL"), AND THE CITY OF MIAMI BEACH, FLORIDA ("SETTLEMENT AGREEMENT"), AS ATTACHED TO THE COMMISSION MEMORANDUM ACCOMPANYING THIS RESOLUTION, TO SETTLE THE LITIGATION STYLED AS CLARK CONSTRUCTION GROUP, LLC, VS. THE CITY OF MIAMI BEACH AND HILL INTERNATIONAL INC., ELEVENTH JUDICIAL CIRCUIT, CASE NO. 2020-002129 CA 01, IN CONNECTION WITH THE MIAMI BEACH CONVENTION CENTER RENOVATION AND EXPANSION PROJECT ("PROJECT"), AND AUTHORIZING THE CITY TO (1) RELEASE \$6,400,000 IN RETAINAGE WITHHELD, IN PAYMENT FOR WORK PERFORMED ON THE PROJECT; (2) APPROVE PAYMENT OF \$9,090,000 WITHHELD AS LIQUIDATED DAMAGES FROM CLARK ON THE PROJECT PAY APPLICATIONS TO ACCOUNT FOR PROJECT-RELATED SCHEDULE DELAYS, IN PAYMENT FOR WORK PERFORMED ON THE PROJECT; AND (3) APPROVE PAYMENT OF AN ADDITIONAL TOTAL AMOUNT OF \$18,010,000, IN FULL SATISFACTION OF ALL PROJECT-RELATED CLAIMS ASSERTED BY CLARK AGAINST THE CITY, INCLUDING, WITHOUT LIMITATION, EXTRA WORK AND CHANGE ORDERS, CLARK'S CLAIM FOR GENERAL CONDITIONS, AND SUBCONTRACTOR IMPACT CLAIMS; WITH THE TOTAL SETTLEMENT AMOUNTS TO BE PAID BY THE CITY IN THE FOLLOWING INSTALLMENT PAYMENTS TO CLARK: \$9,000,000 ON OR BEFORE OCTOBER 15, 2021; \$9,900,000 ON OR BEFORE DECEMBER 31, 2021; \$6,500,000 ON OR BEFORE THE OUTSIDE DATE OF MAY 15, 2022; \$6,500,000 ON OR BEFORE DECEMBER 31, 2022; AND \$1,600,000 IN PERFORMANCE BASED PAYMENTS TIED TO THE COMPLETION OF THE REMAINING WORK MILESTONES AS SET FORTH IN THE SETTLEMENT AGREEMENT; AND FURTHER, AUTHORIZING THE CITY MANAGER AND ACTING CITY ATTORNEY TO TAKE THE NECESSARY AND APPROPRIATE STEPS FOR THE IMPLEMENTATION OF THE SETTLEMENT AGREEMENT, AND AUTHORIZING THE CITY MANAGER AND CITY CLERK TO EXECUTE THOSE DOCUMENTS AND/OR AGREEMENTS NECESSARY TO EFFECTUATE THE SETTLEMENT AGREEMENT CONSISTENT WITH THIS RESOLUTION.

WHEREAS, on May 20, 2015, the Mayor and City Commission adopted Resolution No. 2015-29028, approving the Construction Manager at Risk Agreement ("CMaR Agreement") between the City and Clark Construction Group, LLC ("Clark"), authorizing pre-construction services for the Miami Beach Convention Center Renovation and Expansion Project ("Project") and specifying the terms and conditions for the development and negotiation of a Guaranteed Maximum Price ("GMP") for the construction phase services for the Project; and

WHEREAS, on October 21, 2015, the Mayor and City Commission adopted Resolution No. 2015-29188 authorizing the City to enter into a Construction Manager at Risk Agreement with Clark for the renovation and expansion of the Miami Beach Convention Center Project, with a Guaranteed Maximum Price ("GMP") in the amount of \$515,458,058; and

WHEREAS, on January 31, 2020, Clark filed a \$100 million+ lawsuit, *Clark Construction Group, LLC, vs. City Of Miami Beach And Hill International Inc.*, Eleventh Judicial Circuit Court Case No. 2020-002129 CA 01, against the City and Hill International Inc. ("Hill"), the City's owner's representative for the Project, seeking: (i) a declaration by the Court that it is entitled to significant time extensions, release of retainage and payment for work allegedly completed and within the scope of the contract; (ii) damages for breach of contract; and (iii) damages for Breach of Covenant of Good faith and Fair Dealing; and

WHEREAS, for the reasons as outlined in the accompanying Commission Memorandum, the Mayor and City Commission desire to resolve the matter and approve the Settlement Agreement.

NOW, THEREFORE, BE IT DULY RESOLVED THAT THE MAYOR AND CITY COMMISSION OF THE CITY OF MIAMI BEACH, FLORIDA, that the Mayor and City Commission hereby approve the Settlement Agreement between Clark Construction Group, LLC ("Clark"), Hill International Inc. ("Hill"), and the City of Miami Beach, Florida ("Settlement Agreement"), as attached to the Commission Memorandum accompanying this Resolution, to settle the litigation styled as *Clark Construction Group, LLC, vs. the City Of Miami Beach and Hill International Inc.*, Eleventh Judicial Circuit, Case No. 2020-002129 CA 01, in connection with the Miami Beach Convention Center Renovation and Expansion Project ("Project"), and authorize the City to (1) release \$6,400,000 in retainage withheld, in payment for work performed on the Project; (2) approve payment of \$9,090,000 withheld as liquidated damages from Clark on the Project pay applications to account for Project-related schedule delays, in payment for work performed on the Project; and (3) approve payment of an additional total amount of \$18,010,000, in full satisfaction of all Project-related claims asserted by Clark against the City, including, without limitation, extra work and change orders, Clark's claim for general conditions, and subcontractor impact claims; with the total settlement amounts to be paid by the City in the following installment payments to Clark: \$9,000,000 on or before October 15, 2021; \$9,900,000 on or before December 31, 2021; \$6,500,000 on or before the outside date of May 15, 2022; \$6,500,000 on or before December 31, 2022; and \$1,600,000 in performance based payments tied to the completion of the remaining work milestones as set forth in the Settlement Agreement; and further, authorize the City Manager and Acting City Attorney to take the necessary and appropriate steps for the implementation of the Settlement Agreement, and authorize the City Manager and City Clerk to execute those documents and/or agreements necessary to effectuate the Settlement Agreement consistent with this Resolution.

PASSED and ADOPTED this 30 day of Sept., 2021.

ATTEST:



Dan Gelber, Mayor



Rafael E. Granado, City Clerk



APPROVED AS TO
FORM & LANGUAGE
& FOR EXECUTION

OCT 01 2021

City Attorney

9-28-21
Date

MIAMI BEACH

City of Miami Beach, 1700 Convention Center Drive, Miami Beach, Florida 33139, www.miamibeachfl.gov

COMMISSION MEMORANDUM

TO: Honorable Mayor Dan Gelber and Members of the City Commission

FROM: Alina T. Hudak, City Manager
Rafael Paz, Acting City Attorney

DATE: September 30, 2021

SUBJECT: **A RESOLUTION OF THE MAYOR AND CITY COMMISSION OF THE CITY OF MIAMI BEACH, FLORIDA, APPROVING THE SETTLEMENT AGREEMENT BETWEEN CLARK CONSTRUCTION GROUP, LLC ("CLARK"), HILL INTERNATIONAL INC. ("HILL"), AND THE CITY OF MIAMI BEACH, FLORIDA ("SETTLEMENT AGREEMENT"), AS ATTACHED TO THE COMMISSION MEMORANDUM ACCOMPANYING THIS RESOLUTION, TO SETTLE THE LITIGATION STYLED AS CLARK CONSTRUCTION GROUP, LLC, VS. THE CITY OF MIAMI BEACH AND HILL INTERNATIONAL INC., ELEVENTH JUDICIAL CIRCUIT, CASE NO. 2020-002129 CA 01, IN CONNECTION WITH THE MIAMI BEACH CONVENTION CENTER RENOVATION AND EXPANSION PROJECT ("PROJECT"), AND AUTHORIZING THE CITY TO (1) RELEASE \$6,400,000 IN RETAINAGE WITHHELD, IN PAYMENT FOR WORK PERFORMED ON THE PROJECT; (2) APPROVE PAYMENT OF \$9,090,000 WITHHELD AS LIQUIDATED DAMAGES FROM CLARK ON THE PROJECT PAY APPLICATIONS TO ACCOUNT FOR PROJECT-RELATED SCHEDULE DELAYS, IN PAYMENT FOR WORK PERFORMED ON THE PROJECT; AND (3) APPROVE PAYMENT OF AN ADDITIONAL TOTAL AMOUNT OF \$18,010,000, IN FULL SATISFACTION OF ALL PROJECT-RELATED CLAIMS ASSERTED BY CLARK AGAINST THE CITY, INCLUDING, WITHOUT LIMITATION, EXTRA WORK AND CHANGE ORDERS, CLARK'S CLAIM FOR GENERAL CONDITIONS, AND SUBCONTRACTOR IMPACT CLAIMS; WITH THE TOTAL SETTLEMENT AMOUNTS TO BE PAID BY THE CITY IN THE FOLLOWING INSTALLMENT PAYMENTS TO CLARK: \$9,000,000 ON OR BEFORE OCTOBER 15, 2021; \$9,900,000 ON OR BEFORE DECEMBER 31, 2021; \$6,500,000 ON OR BEFORE THE OUTSIDE DATE OF MAY 15, 2022; \$6,500,000 ON OR BEFORE DECEMBER 31, 2022; AND \$1,600,000 IN PERFORMANCE BASED PAYMENTS TIED TO THE COMPLETION OF THE REMAINING WORK MILESTONES AS SET FORTH IN THE SETTLEMENT AGREEMENT; AND FURTHER, AUTHORIZING THE CITY MANAGER AND ACTING CITY ATTORNEY TO TAKE THE NECESSARY AND APPROPRIATE STEPS FOR THE IMPLEMENTATION OF THE SETTLEMENT AGREEMENT, AND AUTHORIZING THE CITY MANAGER AND CITY CLERK TO EXECUTE THOSE DOCUMENTS AND/OR AGREEMENTS NECESSARY TO EFFECTUATE THE SETTLEMENT AGREEMENT CONSISTENT WITH THIS RESOLUTION.**

PROJECT BACKGROUND

On April 19, 2014, the Mayor and City Commission adopted Resolution No. 2014-28538, approving the execution of an Agreement with Fentress Architects in connection with the development of the Miami Beach Convention Center Renovation Project ("Project"). The scope for the 1,435,000-square-foot convention center Project included the expansion and renovation of the convention center to provide upgraded show needs and enable the center to keep up with the demands of the competitive national and international convention community. The Project includes a new 60,000 square-foot ballroom, new 10,000 square foot kitchen, 127,000 square feet of new meeting space, 500,000 square feet of renovated exhibit space, and a 796 space rooftop parking deck.

On November 19, 2014, the Mayor and City Commission adopted Resolution No. 2014-28849, approving the execution of an Agreement with Hill International ("Hill") for Owners Representative Services.

On May 20, 2015, the Mayor and City Commission adopted Resolution No. 2015-29028, approving the Construction Manager at Risk Agreement ("CMAr Agreement") between the City and Clark Construction Group, LLC ("Clark"), authorizing pre-construction services Project and specifying the terms and conditions for the development and negotiation of a Guaranteed Maximum Price ("GMP") for the construction phase services for the Project.

On October 21, 2015, the Mayor and City Commission adopted Resolution No. 2015-29188 authorizing the City to enter into a Construction Manager at Risk Agreement with Clark for the renovation and expansion of the Miami Beach Convention Center Project, with a Guaranteed Maximum Price ("GMP") in the amount of \$515,458,058. The Resolution also established a Project owner's contingency in the amount of Thirty Five Million Dollars (\$35,000,000), to pay for unforeseen conditions and other work for which the City would be responsible, including for additional architectural / engineering work, permitting and other matters. **The Project Contingency, while significant in dollar amount, represented a contingency of only six percent (6%) over the overall Project budget, significantly less than the standard ten percent (10%) contingency applicable to nearly all other City capital projects.** The Resolution further delegated to the City Manager, the authority to use the contingency to execute any project-related agreements or contract amendments as may be necessary for the successful delivery of the Project.

Pursuant to the CMAr Agreement, Clark was to build the Project for the GMP amount based on 65% construction documents prepared by Fentress, including scopes of work that are "reasonably inferable" from the construction documents. Under those terms, the City assumed certain risks, such as those relating to concealed conditions on the site, as well as changes driven by the Authorities having Jurisdiction (AHJ) (i.e., Building and Fire Departments, franchise utilities such as FP&L and AT&T, and Miami-Dade County Departments such as DERM, DEP, and Miami-Dade-County Traffic, among others).

In December 2015, construction began under a phased permit concurrently with permit reviews and processing of final plans to expedite the permitting process. This was necessary in order to allow Art Basel to have a 4-hall event in December of 2016 and December of 2017 while construction of the project was on-going. In addition to making the building available for Art Basel each year, the CMAr Agreement also required Clark to maintain one half of the building available for events at all times, as directed by the City Commission via Resolution No.2015-28995. The phasing and scheduling of the work was among the most complex in the construction industry, as it required continued operations in and around an active construction site, similar to the complex construction undertaken with large airport projects.

*Settlement Agreement Between Clark Construction Group, Hill International Inc., and City of Miami Beach
September 30, 2021
Page 3 of 8*

The contractual Substantial Completion date (including approved time extensions) was August 23, 2018.

As of August 24, 2018, the City began assessing Liquidated Damages from payments due to Clark at a rate of \$15,000 per day as stipulated in the Agreement.

On February 26, 2019, the City and Clark convened a two-day mediation to discuss outstanding claims. The mediation resulted in a mutual impasse with the parties agreeing to continue to progress with the work on the Project and keep the lines of communication open in order to achieve the common goal of finishing the work as soon as possible.

On July 9, 2019, the City issued a Notice of Default and Opportunity to Cure to Clark. On July 12, 2019 Clark and the City met to discuss possible cure paths, the Project schedule, and outstanding work remaining at the Project. On July 19th, the City proposed a cure plan that itemized the scope of work required to cure and outlined a completion schedule for the Project to achieve a temporary certificate of occupancy (TCO) by September 15th, substantial completion by November 15th, and final completion by January 17, 2020. These milestones were not achieved and the City and Clark continued to disagree on the responsibility of unanticipated costs, i.e what was to be covered by the GMP versus what was beyond the GMP as defined in the contract.

A TCO was issued on April 13, 2020. By this time the City and Clark were in litigation as described and detailed in the following section. **Importantly, the final Certificate of Occupancy for the Project has, to date, not been achieved.**

LITIGATION HISTORY

On January 31, 2020, Clark filed a \$100 million+ lawsuit against the City and Hill International Inc. ("Hill"), the City's owner's representative for the Project. Clark's complaint against the City seeks (i) a declaration by the Court that it is entitled to significant time extensions, release of retainage and payment for work allegedly completed and within the scope of the contract; (ii) damages for breach of contract; and (iii) damages for Breach of Covenant of Good faith and Fair Dealing.

On February 20, 2020, the City filed its Answer, Counterclaim and Third Party Complaint. The City's Counterclaim against Clark alleges: (1) Breach of Contract due to, among other things, Clark's failure to timely complete the work and (2) Breach of the Covenant of Good Faith and Fair dealing. Additionally, the City filed a Third Party Complaint against the Clark's sureties for Breach of Performance Bond. The performance bond guarantees Clark's performance of its contractual obligations to the City under the construction contract, and secures the City by causing the sureties to assume liability for any and all damages, including, but not limited to, liquidated damages arising from Clark's default of its contractual obligations under the agreement.

The scope of this litigation has been extensive. Given the magnitude of the Project and the enormous amount of Clark's initial claim (\$100 million), the litigation has been hard fought and required exhaustive discovery on an expedited timeframe. There were over six million pages of documents produced during the litigation. The parties conducted in excess of sixty depositions, and collectively engaged in excess of twenty experts in multiple fields of expertise, including construction scheduling, delays, design, and construction management standard of care. The parties collectively filed over forty substantive motions in advance of trial, and countless other motions directed to procedural matters.

Despite the protracted litigation, the parties made repeated efforts to resolve the dispute, including two pretrial mediations and, as will be discussed below, a third mediation conducted during the trial.

*Settlement Agreement Between Clark Construction Group, Hill International Inc., and City of Miami Beach
September 30, 2021
Page 4 of 8*

On August 27, 2021, the City conducted a private closed Attorney-Client Session, pursuant to §286.011 of the Florida Statutes, during the City Commission meeting to discuss settlement negotiations and strategy related to litigation expenditures prior to the scheduled trial date of August 30, 2021. Following the private closed session, the City again pursued settlement discussions with Clark. The parties were unable to reach an amicable resolution at that time, and trial of the case commenced on August 30, 2021.

Following opening statements and several days of testimony by fact witnesses, the Court ordered the parties back to mediation with a stern direction that they should make a concerted effort to resolve the dispute. Despite some meaningful progress, the parties were not able to agree on a final settlement during the mediation session, but the Court agreed to a brief recess of the trial so that the parties could resume negotiations. On September 13, 2021, the parties announced to the Court that a tentative agreement had been reached, pending drafting of the settlement documents and approval by the Mayor and City Commission. Based on that announcement, the Court extended the recess until September 30, 2021.

On September 17, 2021, the City reconvened a private Attorney-Client Session, pursuant to §286.011 of the Florida Statutes, during the City Commission meeting, to discuss the progress of the settlement negotiations including a discussion regarding the settlement sum and including settlement terms that would provide for the completion of the Project.

SETTLEMENT

The proposed Settlement Agreement is attached to this Memorandum as Exhibit "A". The proposed Settlement Agreement includes provisions to provide for the completion of the Project and authorizes the City to (1) release the retainage the City has held from Clark for work previously performed in the amount of \$6,400,000; (2) approve payment to Clark in the amount of \$9,090,000 that the City withheld from Clark as Liquidated Damages to account for project related scheduling delays, in payment for work performed on the Project; and (3) approve an additional total amount of \$18,010,000 in full satisfaction of all Project related claims asserted by Clark in the litigation, including, without limitation, extra work and change orders, Clark's claims for additional general conditions, and subcontractor impact claims.

Settlement Summary:	
Total Settlement	\$35,000,000
Less Amount Paid by Hill Directly to Clark	-\$1,500,000
Less Amount Paid by Retainage Held by the City	-\$6,400,000
Total Amount Paid by Other City Funding Sources	\$27,100,000**

****Equates to 4% of the original project budget, which, along with the six percent (6%) contingency originally established for the Project via Resolution 2015-29188, would bring all Project-related contingencies to ten percent (10%), the industry standard for construction-related contingencies and the City's long-established budgeting standard for contingencies on capital projects.**

The payment of the settlement sums are separated into Guaranteed Payments and Performance Based Payments, as set forth below:

Guaranteed Payments:

Payment No.	Amount	Payment Deadline
Payment 1	Ten Million Five Hundred Thousand Dollars (\$10,500,000), comprised as follows: (a) One Million Five Hundred Thousand Dollars (\$1,500,000) from Hill International; (b) Three Million Dollars (\$3,000,000) from the City; and (c) Six Million Dollars (\$6,000,000) from Clark's Retainage	No later than October 15, 2021
Payment 2	Nine Million Nine Hundred Thousand Dollars (\$9,900,000) from the City	No later than December 31, 2021
Payment 3	Six Million Five Hundred Thousand Dollars (\$6,500,000) from the City	No later than April 15, 2022, subject to 30 day extension.
Payment 4	Six Million Five Hundred Thousand Dollars (\$6,500,000) from the City	No later than December 31, 2022

Performance-Based Payments:

Performance Obligation	Amount
Cooling Tower Completion	One Million Two Hundred Thousand Dollars (\$1,200,000) from the City
Stormwater Skimmers/Baffles	One Hundred Thousand Dollars (\$100,000) from Clark's Retainage
Grand Ballroom Flex Ducts	One Hundred Thousand Dollars (\$100,000) from Clark's Retainage
Lighting Completion	One Hundred Thousand Dollars (\$100,000) from Clark's Retainage
Identified Building Leaks	One Hundred Thousand Dollars (\$100,000) from Clark's Retainage

Pursuant to the Settlement Agreement, in order to receive the Performance Based Payments, Clark is required to complete the work identified above, which scopes of work the City anticipates will allow the Project to achieve a Certification of Occupancy. Additionally, Clark has agreed to use its best efforts to complete the Cooling Tower scope on or before January 31, 2022. To this end, the parties have agreed that a neutral third party will make the final determination for completeness and correctness with respect to the remaining scopes of work to be performed. Importantly, Clark has consented to the City's entitlement to seek a judgment for specific performance if Clark fails to complete the work based on the neutral's ultimate determinations. Traditionally, only money damages are an available remedy in these cases. The remedy of specific performance is critical for the City, considering the importance to the City of completing the Project.

In addition to the performance and payment obligations as set forth above, the Settlement Agreement incorporates the following non-monetary considerations: (1) dismissal of the litigation, with prejudice; (2) appointment of a neutral to oversee and approve remaining work; (3) consent to obtain specific performance judgment for Clark to finish work; (4) a retraction of the City's Notice of Default to Clark; (5) joint letter regarding the Project; (6) Clark and the City agreeing to a substantial completion date of April 13, 2020, Clark agreeing to vacate an adverse Order entered against the City regarding the Propt Payment Act; (7) mutual releases; and (8) mutual non-disparagement.

ANALYSIS

If this settlement is not approved, trial will resume on October 1, 2021. It is anticipated that the trial will last at least ten weeks. Further, and irrespective of the outcome, it is anticipated that an appeal will follow the conclusion of the trial. The appellate process can be expected to last 12 to 18 months. In short, if this litigation continues, it will not be concluded until 2023, at substantial additional costs, and without achieving the City's desired goal of the final completion of the Project.

The monetary terms of this settlement are fair and reasonable, and consistent with the reasonable range of possible outcomes at trial should the litigation proceed. In addition to resolving the dispute over the amounts to be paid, the Settlement Agreement also requires Clark to complete certain work necessary to obtain the final certificate of occupancy, and affords the City the remedy of specific performance. This is an important provision because, without it, the Court would not have the power to force Clark to complete the work (the Court would only have the power to award a money judgment).

Project Challenges

From inception the project was met with a unique set of challenges which increased both the owner's and the construction manager's risk. The catalyst of that risk was the decision by the City Commission in 2014 to keep the building operational by hosting events during the entire construction period. This included hosting half-hall events at all times, and full-hall Art Basel events every year, regardless of the condition of the building. To accomplish that goal, the public had to be protected by the construction of two-hour separation walls that had to be installed and demolished twice during the construction period. Over ninety events took place during construction including the NFL experience (LIV) and the "Fanfest" for major league baseball. These events brought tens of thousands of visitors to the facility and required a substantial and unforeseen amount of life-safety requirements, including fire watch and additional show support, which were grossly underestimated.

In addition, two hurricanes occurred during construction; Hurricane Matthew in 2016 and Hurricane Irma in 2017. Both hurricanes were declared states of emergency which required the entire site and labor force to demobilize. Also, a "rain bomb" event in 2017 caused damaged to the east side pre-function space which was partially completed and needed to be repaired before re-opening. Ten separate Builder's Risk Insurance claims had to be filed during construction due to damages caused, not only by these storms, but also accidental fires and other issues.

Other unknown challenges involved the existing facility itself. Sixty nine percent (69%) of the facility was re-used and those remaining portions were built between 1959 and 1986. Lead-based paint was discovered in a portion of that area which had to be properly removed. City record drawings also showed one-hour rated walls to remain, which did not exist. The walls had to be completely reconstructed to meet current code.

Another unforeseen encounter involved the existing kitchen facility on the east side of the building. It was originally anticipated that this kitchen would remain operational until the new 10,000 square foot kitchen was completed, however life safety concerns required that the east kitchen be closed, and a temporary kitchen be set up within the south loading dock to continue to provide food service to scheduled events.

Other challenges, although known at the time, were much more difficult to manage due to the constant event schedule. This included asbestos removal, different building floor levels ranging by as much as four inches which needed to be shimmed during events, and a high number of construction crews from different contractors that had to work alongside with Clark and their subs. These included contractors from Florida Power & Light which installed three new electrical vaults within the building, separate city contractors which installed two storm water pump stations while Clark was raising and completing roadways, separate contractors for five unique public art

installations built in between scheduled events, and separate city contractors for the Carl Fisher Clubhouse and Pride Park construction projects.

Finally, and as everyone is aware, a COVID-19 acute care temporary hospital was built by the Army Corp. of Engineers for the Florida Department of Emergency Management with their own contractor soon after the project received its temporary certificate of occupancy (TCO). The possession of the building by the Army Corp. lasted for six months and stalled the final completion of the building.

During the entire time the project was under construction, the City committed to its neighbors that they would remain operational, and resident's quality of life would not be impacted by the enormity of the project. This included all the neighboring condominiums, Miami Beach High School, the Botanical Garden, The Fillmore Theater, and City Hall including the parking garage structure being used 24 hours a day.

Owner's Contingency:

The City addressed unknown conditions and project challenges through the creation of a 6% owner's contingency. While projects of this size, and nearly all City capital projects, carry a 10% contingency, at the Project's inception, it was believed the Project could be completed with a lower level of contingency. Ultimately, with the approval of this settlement, an Owner's contingency of 10% was actually required. After considering the challenges noted above, it is fair and reasonable to assume the customary contingencies that other projects are normally provided to apply.

Original Project Budget	\$ 615,722,930	
Original Contingency	\$ 35,000,000	6%
Settlement	\$ 27,100,000	4%
Total Amount for Project Contingencies		10%

Fentress Architects Indemnity Obligation

A substantial portion of Clark's claim is based on allegations that portions of the design were either deficient, incomplete or uncoordinated. The design for the project was provided by Fentress Architects and a number of consulting engineers that were hired by Fentress. The agreement between the City and Fentress includes an indemnity provision which requires Fentress to indemnify the City against any losses it sustains as a result of deficient work by Fentress or its consulting engineers. The City will look to Fentress to indemnify it for losses it sustained, and intends to pursue its claims to recover the portions of the settlement payments, plus fees and costs of defense, resulting from design issues.

FUNDING SOURCES

The Miami Beach Convention Center is Miami-Dade County's largest convention center and an important regional asset for supporting the local economy. The MBCC Renovation and Expansion Project was largely funded with Miami Beach Redevelopment Agency (RDA) bonds approved by Miami-Dade County pursuant to an RDA Interlocal Agreement. The City's portion of the settlement is \$27.1 million and is anticipated to ultimately be covered by the excess funds in the City Center RDA of approximately \$28.1 million. Of the \$28.1 million, the City portion is estimated at \$15.5 million and the County portion is estimated at \$12.6 million. Under the Interlocal Agreement, the excess Miami Beach RDA Trust Fund revenues can only be used for the early prepayment of RDA bonds or, with Miami-Dade County and City approval, to defray the costs of an RDA capital project like the MBCC Renovation and Expansion Project.

The Administration has initiated discussions with Miami-Dade County with regard to the possibility of amending the City's RDA Interlocal Agreement to utilize existing excess Miami Beach RDA Trust

Settlement Agreement Between Clark Construction Group, Hill International Inc., and City of Miami Beach
September 30, 2021
Page 8 of 8

Fund revenues to fund all or a portion of the settlement. Although discussions with the County have been initiated, it would likely take several months to negotiate the necessary amendment to the RDA Interlocal Agreement. In order to cover the first two payments in the Settlement that are due on October 15 and December 31, 2021, the Administration is recommending realigning existing funds from the Transportation Initiatives capital project. This realignment is recommended as a change to the Proposed FY 2022 Capital Budget so the funds would be in place as of the new fiscal year on October 1st, in time for the first payment on October 15th. If the City Center RDA interlocal agreement is successfully amended over the next several months, these funds would be replaced by the City Center RDA funds.

JOINT RECOMMENDATION OF THE CITY MANAGER AND ACTING CITY ATTORNEY

This settlement (i) eliminates the risk of a potentially adverse judgment in an amount far in excess of the settlement sum; (ii) resolves the payment dispute for an amount that we believe is consistent with, and within the reasonable range of possibility for, what the Court may award should the trial proceed; (iii) eliminates the substantial costs, risk and uncertainty associated with a ten week trial and what is expected to be an eighteen month appellate process; (iv) requires that Clark complete work that is necessary for obtaining a certificate of occupancy, the best and most efficient way to achieve the City's goal of final completion of the Project; (v) provides for a neutral to make quick and binding decisions in the event a dispute arises about whether Clark's obligations to complete the work are satisfied; and (vi) affords the City the remedy of specific performance which enables the Court to issue an order requiring Clark to complete the required work.

Accordingly, for the reasons set forth in this Commission Memorandum, the City Manager and the Acting City Attorney jointly recommend that the Mayor and City Commission adopt the Resolution and approve the Settlement Agreement, as being in the best interests of the City.

ATTACHMENTS:

Settlement Agreement

ATH / RP / MH 

RESOLUTION NO. 2021-_____

A RESOLUTION OF THE MAYOR AND CITY COMMISSION OF THE CITY OF MIAMI BEACH, FLORIDA, APPROVING THE SETTLEMENT AGREEMENT BETWEEN CLARK CONSTRUCTION GROUP, LLC ("CLARK"), HILL INTERNATIONAL INC. ("HILL"), AND THE CITY OF MIAMI BEACH, FLORIDA ("SETTLEMENT AGREEMENT"), AS ATTACHED TO THE COMMISSION MEMORANDUM ACCOMPANYING THIS RESOLUTION, TO SETTLE THE LITIGATION STYLED AS CLARK CONSTRUCTION GROUP, LLC, VS. THE CITY OF MIAMI BEACH AND HILL INTERNATIONAL INC., ELEVENTH JUDICIAL CIRCUIT, CASE NO. 2020-002129 CA 01, IN CONNECTION WITH THE MIAMI BEACH CONVENTION CENTER RENOVATION AND EXPANSION PROJECT ("PROJECT"), AND AUTHORIZING THE CITY TO (1) RELEASE \$6,400,000 IN RETAINAGE WITHHELD, IN PAYMENT FOR WORK PERFORMED ON THE PROJECT; (2) APPROVE PAYMENT OF \$9,090,000 WITHHELD AS LIQUIDATED DAMAGES FROM CLARK ON THE PROJECT PAY APPLICATIONS TO ACCOUNT FOR PROJECT-RELATED SCHEDULE DELAYS, IN PAYMENT FOR WORK PERFORMED ON THE PROJECT; AND (3) APPROVE PAYMENT OF AN ADDITIONAL TOTAL AMOUNT OF \$18,010,000, IN FULL SATISFACTION OF ALL PROJECT-RELATED CLAIMS ASSERTED BY CLARK AGAINST THE CITY, INCLUDING, WITHOUT LIMITATION, EXTRA WORK AND CHANGE ORDERS, CLARK'S CLAIM FOR GENERAL CONDITIONS, AND SUBCONTRACTOR IMPACT CLAIMS; WITH THE TOTAL SETTLEMENT AMOUNTS TO BE PAID BY THE CITY IN THE FOLLOWING INSTALLMENT PAYMENTS TO CLARK: \$9,000,000 ON OR BEFORE OCTOBER 15, 2021; \$9,900,000 ON OR BEFORE DECEMBER 31, 2021; \$6,500,000 ON OR BEFORE THE OUTSIDE DATE OF MAY 15, 2022; \$6,500,000 ON OR BEFORE DECEMBER 31, 2022; AND \$1,600,000 IN PERFORMANCE BASED PAYMENTS TIED TO THE COMPLETION OF THE REMAINING WORK MILESTONES AS SET FORTH IN THE SETTLEMENT AGREEMENT; AND FURTHER, AUTHORIZING THE CITY MANAGER AND ACTING CITY ATTORNEY TO TAKE THE NECESSARY AND APPROPRIATE STEPS FOR THE IMPLEMENTATION OF THE SETTLEMENT AGREEMENT, AND AUTHORIZING THE CITY MANAGER AND CITY CLERK TO EXECUTE THOSE DOCUMENTS AND/OR AGREEMENTS NECESSARY TO EFFECTUATE THE SETTLEMENT AGREEMENT CONSISTENT WITH THIS RESOLUTION.

WHEREAS, on May 20, 2015, the Mayor and City Commission adopted Resolution No. 2015-29028, approving the Construction Manager at Risk Agreement ("CMaR Agreement") between the City and Clark Construction Group, LLC ("Clark"), authorizing pre-construction services for the Miami Beach Convention Center Renovation and Expansion Project ("Project") and specifying the terms and conditions for the development and negotiation of a Guaranteed Maximum Price ("GMP") for the construction phase services for the Project; and

WHEREAS, on October 21, 2015, the Mayor and City Commission adopted Resolution No. 2015-29188 authorizing the City to enter into a Construction Manager at Risk Agreement with Clark for the renovation and expansion of the Miami Beach Convention Center Project, with a Guaranteed Maximum Price ("GMP") in the amount of \$515,458,058; and

WHEREAS, on January 31, 2020, Clark filed a \$100 million+ lawsuit, *Clark Construction Group, LLC, vs. City Of Miami Beach And Hill International Inc.*, Eleventh Judicial Circuit Court Case No. 2020-002129 CA 01, against the City and Hill International Inc. ("Hill"), the City's owner's representative for the Project, seeking: (i) a declaration by the Court that it is entitled to significant time extensions, release of retainage and payment for work allegedly completed and within the scope of the contract; (ii) damages for breach of contract; and (iii) damages for Breach of Covenant of Good faith and Fair Dealing; and

WHEREAS, for the reasons as outlined in the accompanying Commission Memorandum, the Mayor and City Commission desire to resolve the matter and approve the Settlement Agreement.

NOW, THEREFORE, BE IT DULY RESOLVED THAT THE MAYOR AND CITY COMMISSION OF THE CITY OF MIAMI BEACH, FLORIDA, that the Mayor and City Commission hereby approve the Settlement Agreement between Clark Construction Group, LLC ("Clark"), Hill International Inc. ("Hill"), and the City of Miami Beach, Florida ("Settlement Agreement"), as attached to the Commission Memorandum accompanying this Resolution, to settle the litigation styled as *Clark Construction Group, LLC, vs. the City Of Miami Beach and Hill International Inc.*, Eleventh Judicial Circuit, Case No. 2020-002129 CA 01, in connection with the Miami Beach Convention Center Renovation and Expansion Project ("Project"), and authorize the City to (1) release \$6,400,000 in retainage withheld, in payment for work performed on the Project; (2) approve payment of \$9,090,000 withheld as liquidated damages from Clark on the Project pay applications to account for Project-related schedule delays, in payment for work performed on the Project; and (3) approve payment of an additional total amount of \$18,010,000, in full satisfaction of all Project-related claims asserted by Clark against the City, including, without limitation, extra work and change orders, Clark's claim for general conditions, and subcontractor impact claims; with the total settlement amounts to be paid by the City in the following installment payments to Clark: \$9,000,000 on or before October 15, 2021; \$9,900,000 on or before December 31, 2021; \$6,500,000 on or before the outside date of May 15, 2022; \$6,500,000 on or before December 31, 2022; and \$1,600,000 in performance based payments tied to the completion of the remaining work milestones as set forth in the Settlement Agreement; and further, authorize the City Manager and Acting City Attorney to take the necessary and appropriate steps for the implementation of the Settlement Agreement, and authorize the City Manager and City Clerk to execute those documents and/or agreements necessary to effectuate the Settlement Agreement consistent with this Resolution.

PASSED and ADOPTED this _____ day of _____, 2021.

ATTEST:

Dan Gelber, Mayor

Rafael E. Granado, City Clerk

APPROVED AS TO
FORM & LANGUAGE
& FOR EXECUTION



City Attorney

9-28-21

Date

SETTLEMENT AGREEMENT

THIS SETTLEMENT AGREEMENT (the “**Agreement**”) is entered into by and between CLARK CONSTRUCTION GROUP, LLC (“**Clark**”), THE CITY OF MIAMI BEACH, FLORIDA (the “**City**”), and HILL INTERNATIONAL, INC. (“**Hill**”). Clark, the City, and Hill are collectively referred to as the “**Parties**,” and individually each is referred to as a “**Party**.” This Agreement’s effective date is the date it is approved by the City Commission of the City of Miami Beach pursuant to Section 15 below (the “**Effective Date**”).

RECITALS:

WHEREAS, on or about May 21, 2015, Clark and the City executed a Construction Manager at Risk Agreement (the “**CMAr Agreement**”), under which Clark was to act as the construction manager for the Renovation and Expansion of the Miami Beach Convention Center (the “**Project**”).

WHEREAS, TRAVELERS CASUALTY AND SURETY COMPANY OF AMERICA (“**Travelers**”), FEDERAL INSURANCE COMPANY (“**Federal**”), FIDELITY AND DEPOSIT COMPANY OF MARYLAND (“**Fidelity**”), and ZURICH AMERICAN INSURANCE COMPANY (“**Zurich**”) (Travelers, Federal, Fidelity, and Zurich are collectively referred to as the “**Sureties**”) issued a Payment and Performance Bond (the “**Bond**”) for the Project pursuant to Section 255.05, Florida Statutes, with Clark as principal thereunder.

WHEREAS, on or about October 30, 2015, the City and Hill executed an Owner’s Representative Services Agreement (“**OR Agreement**”) under which Hill was to provide the City with oversight and administrative support services for the performance of the CMAr Agreement.

WHEREAS, during the Project, certain disputes arose between Clark, the City, and Hill.

WHEREAS, on January 29, 2020, Clark filed a lawsuit against the City and Hill in the Eleventh Judicial Circuit Court in and for Miami-Dade County, Florida captioned as *CLARK CONSTRUCTION GROUP, LLC. v. THE CITY OF MIAMI BEACH, FLORIDA and HILL INTERNATIONAL, INC.*, Case No. 2020-002129-CA-01. In its Complaint, Clark alleges claims of declaratory relief, breach of contract, and breach of the implied covenant of good faith and fair dealing against the City, and claims of negligence and tortious interference against Hill (the “**Complaint**”).

WHEREAS, the City responded to the Complaint by filing a Counterclaim against Clark alleging claims of breach of contract, building code violations, and breach of the covenant of good faith and fair dealing against Clark (the “**Counterclaim**”). The City further filed a Third-Party Complaint against the Sureties alleging claims against the Bond (the “**Third-Party Complaint**”). The Complaint, the Counterclaim, and the Third-Party Complaint are collectively referred to herein as the “**Action**.”

WHEREAS, for purposes of avoiding costly litigation and in order to reach a resolution of the claims and disputes by and among the Parties, the Parties deem it in their best interest to settle and compromise and to enter into a final settlement agreement.

127294236.1
127294236.v1

MC ARB

THEREFORE, in consideration of the foregoing and the agreements set forth in this Agreement, and for other good and valuable consideration, the sufficiency of which are hereby acknowledged, the Parties, intending to be legally bound, agree as follows:

1. **Recitals.** The Parties agree that the foregoing Recitals are true and correct and incorporated herein by reference.

2. **The City's and Hill's Settlement Payments to Clark.** The City shall pay to Clark Thirty-Three Million Five Hundred Thousand Dollars (\$33,500,000.00) and Hill shall pay to Clark One Million Five Hundred Thousand Dollars (\$1,500,000.00), for a total sum of Thirty-Five Million Dollars (\$35,000,000.00) (the "**Settlement Sum**"), comprised of four (4) guaranteed payments and five (5) performance-based payments, in accordance with the following payment schedule:

(a) **Guaranteed Payments.** The following four (4) payments are guaranteed ("**Guaranteed Payments**") and shall be made on or before the stated Payment Deadlines below, notwithstanding any alleged failure by any Party with respect to any obligations stated herein.

Payment No.	Amount	Payment Deadline
Payment 1	Ten Million Five Hundred Thousand Dollars (\$10,500,000.00), comprised as follows: (a) One Million Five Hundred Thousand Dollars (\$1,500,000.00) from Hill; and (b) Nine Million Dollars (\$9,000,000.00) from the City	No later than October 15, 2021
Payment 2	Nine Million Nine Hundred Thousand Dollars (\$9,900,000.00) from the City	No later than December 31, 2021
Payment 3	Six Million Five Hundred Thousand Dollars (\$6,500,000.00) from the City	No later than April 15, 2022, subject to subsection 2(b) below.
Payment 4	Six Million Five Hundred Thousand Dollars (\$6,500,000.00) from the City	No later than December 31, 2022

Except as otherwise provided in this Agreement, upon payment of the One Million Five Hundred Thousand Dollars (\$1,500,000.00) set forth in this Section 2(a), Hill shall have no further obligations to Clark and Clark shall have no further obligations to Hill.

(b) The City expects that the source for a portion of the funds will be the City of Miami Beach Redevelopment Agency ("RDA"), which will require the approval of both the City of Miami Beach Commission and the Miami-Dade County Board of Commissioners. The City will employ its best efforts to take all steps necessary to obtain approval from Miami-Dade County to authorize the release of the RDA funds. In the event the Miami-Dade County Board of

MM *RS*

Commissioners sends this matter to a sub-committee in order to receive funding in connection with this Agreement, the deadline for Payment 3, and only Payment 3, shall be extended by thirty (30) days such that the City must make Payment 3 no later than May 15, 2022. In the event that Miami-Dade County approves the RDA funds before the payment deadlines set forth herein for Payment 3, the City shall make Payment 3 within five days of Miami Dade County's approval of the RDA funds. Except as otherwise expressly provided by this Section (b), the City's payment obligations under this Agreement shall not be affected by any action or inaction of the Miami-Dade County Board of Commissioners or the RDA.

(c) **Performance-Based Payments.** The following five (5) payments (the "Performance-Based Payments") shall be released upon Clark's performance of the obligations described in Section 3 below, and the City shall make each payment to Clark in accordance with Section 4 below.

Associated Obligation	Amount	Reference in Agreement
Cooling Tower	One Million Two Hundred Thousand Dollars (\$1,200,000.00)	Section 3(a)
Skimmers/Baffles	One Hundred Thousand Dollars (\$100,000.00)	Section 3(b)
Grand Ballroom Flex Ducts	One Hundred Thousand Dollars (\$100,000.00)	Section 3(c)
Lighting	One Hundred Thousand Dollars (\$100,000.00)	Section 3(d)
Identified Building Leaks	One Hundred Thousand Dollars (\$100,000.00)	Section 3(e)

(d) If the City fails to make any Guaranteed Payment by the applicable date specified in Section 2(a) above or Performance-Based Payment in accordance with Sections 3 and 4 below, Clark shall issue a "Notice of Default," which shall allow the City five (5) business days to cure its non-payment default. In the event the City fails to cure its default, Clark shall be entitled to an immediate default judgment against the City in the amount of the outstanding payment due under the terms of this Agreement, default interest in the maximum amount permitted under the law accruing from the date of the payment obligation, and reasonable attorney's fees and costs associated with enforcement of this provision.

(e) Separate from the Settlement Sum, the City shall make payment to Clark for the Cooling Tower Work, pursuant to Section 3(a) below, which amount shall total \$1,200,000.00.

3. **Clark's Remaining Project Obligations.** As part of this Agreement, Clark agrees to perform or cause to be performed the following Project tasks ("Remaining Project Obligations"), subject to the terms and conditions set forth herein:

127294236.1
 127294236.v1

(a) **Cooling Tower Work**

(i) Clark shall perform or cause to be performed the cooling tower work as identified in the Revision S Drawings which are attached hereto as **Composite Exhibit A** (the "Cooling Tower Work") which costs are identified in Owner Change Orders 207, 208, and 209, and the related conditional release (the "Cooling Tower COs").

(ii) Clark shall be compensated for the Cooling Tower Work in accordance with the Cooling Tower COs, and Clark shall invoice the City against the Cooling Tower COs individually as opposed to submitting Applications for Payment. At the time of the invoicing, Clark shall provide the City, to the extent practicable: (a) an invoice from each subcontractor with a similar schedule of values to that indicated in the applicable subcontractor proposal; and (b) if requested, the appropriate proof of purchase for any stored materials. Clark shall not be required to provide any further documentation.

(iii) The City confirms that it has directed Clark to proceed with the Cooling Tower Work. Clark agrees to use its best efforts to complete the Cooling Tower Work on or before January 31, 2022, based on the current event calendar for the building attached hereto as **Exhibit B**. Clark shall provide the City with a schedule to complete the Cooling Tower Work within five (5) business days following the Effective Date. The schedule that Clark provides to the City shall be a good faith estimate of Clark's timing with respect to completion of the Cooling Tower Work. The City agrees to use its best efforts to assist Clark in meeting the deadlines in the estimated schedule. The City and Clark acknowledge that Clark's ability to complete the Cooling Tower Work on or before January 31, 2022 is subject to events, circumstances, or matters that are outside of Clark's control, including, but not limited to, Clark's ability to access the Project, the City's timely payment, the full cooperation of the City and any other third parties, including the relevant authorities having jurisdiction ("AHJs"), and the occurrence of unforeseen or *force majeure* events.

(iv) Upon Clark's completion of the work contained in any of the Cooling Tower COs, Clark shall notify the Decision-Maker, as defined below, with a copy of such notice to the City, of its completion of the work in the applicable Cooling Tower CO. Upon the Decision-Maker's determination that Clark has completed any of the work contained in the applicable Cooling Tower CO, the City shall pay the corresponding amount for that work within fifteen (15) days of such determination. In the event the City fails to make payment within the fifteen (15) day period, Clark may cease any further work contemplated in this Section 3(a) and seek expedited relief from the Court to enforce the terms of this Agreement, including accrued interest on the amounts due.

(v) Clark shall have no obligation to perform any extra work relating to the cooling tower that is not expressly identified in **Composite Exhibit A**, except to the extent that

Handwritten signature and initials: "ML" with "aB" next to it.

such extra work work is directly caused by Clark's deficient performance of the Cooling Tower Work. The Parties agree that Clark shall have no responsibility for the design or performance of the cooling tower.

(vi) Except as provided herein, the City is responsible for performing and paying for any extra work above and beyond the work specified in Composite Exhibit A, and the Cooling Tower COs, and Clark shall have complete discretion to accept or reject responsibility for performing any such work if requested.

(b) **Grand Ballroom Flex Ducts.** Clark shall repair the flex ducts located in the Project's Grand Ballroom which are identified in Exhibit C, which is attached hereto. Clark shall have no obligation to perform any extra work relating to the work that is not expressly identified in Exhibit C, except to the extent necessary to cure any deficiencies directly caused by Clark's deficient performance of the work identified in Exhibit C.

(c) **Skimmers/Baffles.** Clark shall repair the skimmers/baffles identified in Exhibit D, which is attached hereto. Clark shall have no obligation to perform any extra work relating to the work that is not expressly identified in Exhibit D, except to the extent necessary to cure any deficiencies directly caused by Clark's deficient performance of the work identified in Exhibit D.

(d) **Lighting.** On or before September 30, 2021, Clark shall provide the City with a list of the parts/materials it believes to be necessary for the completion of the items identified in Exhibit E, which is attached hereto, and shall place the order for the materials no later than October 30, 2021. The City shall be responsible for paying for the parts/materials associated with this order and the City shall cooperate with Clark as necessary to facilitate the placement of the order. Upon placement of the order, Clark's sole responsibility with respect to this Section 3(d) work is to coordinate and/or supervise performance of the lighting work identified in Exhibit E by the appropriate subcontractor or third-party. The Parties hereby agree that if any portion of this work is not completed by March 1, 2022, the City or Clark may request the Decision Maker to determine the labor cost to the City of having the remaining work completed by a qualified and licensed electrician, and that amount shall be withheld from the Performance-Based Payment associated with the work in this Section 3(d). The City shall release the balance of the Performance-Based Payment associated with this Section 3(d) within fifteen (15) calendar days of the Decision-Maker's determination of the labor cost associated with the remaining lighting work on Exhibit E which is the subject of this Section, and Clark shall bear no further responsibilities or obligations with respect to the light work contemplated herein.

(e) **Identified Building Leaks.** Clark shall submit the City's warranty claims regarding the three (3) roof leaks identified in Exhibit F, which is attached hereto, to Tecta America South Florida, Inc. ("Tecta") or other appropriate subcontractor or third party, and coordinate Tecta's performance of the work. Clark, however, shall have no obligation to the City to undertake the repairs. Clark's obligations under this Section 3(e) shall be complete upon Tecta notifying Clark that it has completed the work identified in Exhibit F.

AKS

(f) **Close-out Documents:** Clark shall submit to the City all close out documents identified in Exhibit G.

(g) **Specific Performance.** If the City believes Clark is not fulfilling a Remaining Project Obligation in accordance with the terms of this Agreement, the City may petition the Decision-Maker to order Clark to specifically perform that obligation. The Decision-Maker shall determine whether Clark is using commercially reasonable efforts to complete the work and/or whether Clark is being prevented from completing the work based on lack of access, materials, City cooperation, or some other ground that is impacting Clark's ability to timely comply with its obligations under this Agreement. If the Decision-Maker finds that Clark has failed to prosecute the work as required pursuant to this Agreement, then the Decision-Maker may order Clark to specifically perform that work and set what he deems to be a reasonable time for the completion of the work. In the event that Clark does not perform work that the Decision-Maker has ordered to be specifically performed due to unavailability of supplies or resources, *force majeure*, lack of City cooperation, any changes made or undertaken relating to the cooling tower, lack of access, or the occurrence of an unforeseen event that renders performance impossible or impracticable, then the Parties may seek relief as provided in Section 4(b) or Section 18(c) below, as applicable.

4. Procedure for Certifying Completion of Remaining Project Obligations and Release of Performance-Based Payments

(a) **The Decision-Maker.** The Parties will appoint a neutral decision-maker (the "**Decision-Maker**") on or before September 24, 2021 from either Vanderweil Engineers, LLP or TLC Engineering Solutions, Inc., to handle all disputes relating to the Remaining Project Obligations described in Section 3 above and to certify when completion of the Remaining Project Obligations has been achieved in accordance with this Agreement, including subsections 4(b) and 4(c) below. The Decision-Maker's findings shall be final and binding on the Parties, regardless of whether such work has passed inspection or otherwise been accepted by the City or applicable AHJs. In other words, if the Decision-Maker determines that Clark has completed a disputed component of work required under this Agreement, Clark shall have no further obligation with respect to said work, irrespective of the City's or an AHJ's rejection of the work or requirement for additional work, and irrespective as to whether the City agrees or disagrees. By contrast, if the Decision Maker decides that Clark has not completed a disputed component of the work required under this Agreement, Clark shall be obligated to complete the work irrespective of whether the work has been approved by the AHJ and whether Clark agrees or disagrees. In the event that any party fails to comply with the determination of the Decision-Maker (*i.e.*, the City fails to comply with a payment obligation or Clark fails to comply with a performance obligation), the other Party's sole and exclusive remedy is to seek the appropriate relief from the Court pursuant to Section 18(a)-(c) below. In the event the Decision-Maker can no longer serve as Decision-Maker, the City and Clark shall work in good faith to select a mutually agreeable replacement with requisite construction experience to evaluate Clark's work and resolve any related disputes. In the event the City and Clark cannot agree on the selection of, or replacement for the Decision-Maker,

MC ars

the Court shall appoint a Decision-Maker with appropriate technical construction expertise. All fees incurred by the Decision-Maker shall be split equally between the City and Clark.

(b) **Certification of Completion.** When Clark believes it has completed any of its Remaining Project Obligations, it shall promptly notify the City and the Decision-Maker of such completion. The Decision-Maker shall then provide a written determination as to whether Clark has completed the work associated with the Remaining Project Obligation submitted to the Decision-Maker. The Parties shall promptly submit all documentation that the Decision-Maker requests for the purpose of evaluating Clark's completion of the submitted item. The City agrees to provide access to the Project for an in-person inspection in the event the Decision-Maker requests such an inspection. In the event the Decision-Maker determines that either Party has not provided information he requires to make such determination, then the Decision-Maker, following a reasonable time for the respective Party to cure, in his discretion, may find that (i) Clark has not completed the work and is therefore not entitled to payment, or (ii) the City has waived its right to claim that the work has not been completed and is therefore required to make payment to Clark. If the Decision-Maker determines that Clark has sufficiently completed the submitted Remaining Project Obligation, then the City must pay Clark the Performance-Based Payment associated with that work, as identified in Section 2(c) above, within fifteen (15) calendar days of the Decision-Maker's written decision. For example, if the Decision-Maker determines that Clark has completed the Cooling Tower Work (Section 3(a)), then the City must release the One Million Two Hundred Thousand Dollars (\$1,200,000.00) Performance-Based Payment listed in Section 2(c) above within fifteen (15) calendar days of the Decision-Maker issuing a written decision with his finding. Clark and the City shall follow this process with respect to each Remaining Project Obligation. Clark may submit the Remaining Project Obligations to the Decision-Maker, on an individual basis or on a collective basis.

If the Decision-Maker finds that Clark has not completed a submitted Remaining Project Obligation, then, subject to Section 4(c) below, the Decision-Maker shall specify in writing the remaining work to be completed for the Remaining Project Obligation. Clark shall be required to return to the Project, complete the incomplete work identified by the Decision-Maker, and re-notify the City and Decision-Maker when Clark believes it has sufficiently addressed the remaining work.

(c) **Partial Certification of Completion.** In the event Clark is unable to fully complete a Remaining Project Obligation due to unavailability of supplies or resources, *force majeure*, lack of City cooperation, any changes made or undertaken relating to the cooling tower, lack of access, or the occurrence of an unforeseen event that renders performance impossible or impracticable, Clark shall promptly notify the City and the Decision-Maker of such inability. The Decision-Maker shall issue to Clark and the City a written decision on (i) whether circumstances render Clark's performance of the Remaining Project Obligation impossible or impracticable or whether the City has prevented or impeded Clark from its performance of the Remaining Project Obligation and, if so, (ii) the appropriate relief to address the Decision-Maker's finding, which may include, but is not limited to, that Clark shall be relieved of its responsibility of performing the Remaining Project Obligation and is entitled to the Performance-Based Payment associated

ARS

CLARK CONSTRUCTION GROUP, LLC v. THE CITY OF MIAMI BEACH, FLORIDA, ET AL.
 Settlement and Release Agreement
 Page 8 of 17

with the Remaining Project Obligation submitted under this Section 4(c). The City shall make such payment, if applicable, within **fifteen (15) calendar days** of the Decision-Maker's written decision. If the Decision-Maker determines that Clark is capable of completing a Remaining Project Obligation submitted under this Section 4(c) with reasonable efforts, then the Decision-Maker shall specify the remaining work to be completed for the Remaining Project Obligation. Clark shall be required to return to the Project, complete the incomplete work identified by the Decision-Maker, and re-notify the City and Decision-Maker when Clark believes it has sufficiently addressed the remaining work. In the event Clark does not complete one of its Remaining Project Obligations despite a determination from the Decision-Maker that it must complete the work, the City's sole and exclusive remedy is contained in Section 18, below.

5. **The Low Voltage Items.** The City has raised an issue concerning low voltage cables relating and limited to the 1,252 cables that have been identified as "failed" and other cables exceeding 295 feet in length which are identified in the Structured Cabling System Test Reports submittal 271000-037.1 dated July 21, 2020 (the "Low Voltage Items"). The Parties agree that these limited Low Voltage Items are not being resolved by this Agreement and that any dispute between the City, Clark, and MC Dean, Inc. relating to the Low Voltage Items will be brought in front of Jeff Beavers at BICSI or, if Mr. Beavers is not available, alternatively, a mutually agreeable third party, for final adjudication on or before October 15, 2021, with no right to appeal. The scope of the dispute will be limited to the Low Voltage Items, as the term is defined above. The City shall be responsible for 50% of the fees and costs incurred by Mr. Beavers or the otherwise designated third party adjudicator.

6. **The City's July 9, 2019 Notice of Default.** The City hereby rescinds its July 9, 2019 Notice of Default issued to Clark relating to the Project. The City further acknowledges that as of the Effective Date, there exists no outstanding default by Clark with respect to the Project.

7. **City Letter Regarding the Project.** Upon the completion of the work contemplated by Section 3(a) of this Agreement (i.e., the Cooling Tower Work), the City shall execute the letter attached hereto as **Exhibit H.**

8. **Substantial Completion Date.** The City and Clark agree that Substantial Completion was reached on April 13, 2020. Within five (5) business days of the Effective Date, the City shall issue a Certificate of Substantial Completion with an effective date of April 13, 2020, and, in consideration of the compromise and settlement set forth in this Agreement, the parties agree that the contractual Substantial Completion date is extended to April 13, 2020.

9. **The Court's Local Government Prompt Payment Act Order.** Within two (2) business days of Effective Date, the Parties shall file a joint stipulation requesting the Court to vacate the Court's September 24, 2020 Order Granting Clark's Motion for Partial Summary Judgment on Count II of the Complaint relating to Florida's Local Government Prompt Payment Act.

127294236.1
 127294236.v1

ARS

10. **Warranties**

(a) The City agrees that all subcontractor, installer, and/or manufacturer warranties required under the CMaR Agreement have been submitted pursuant to the submittal numbers indicated on the document attached hereto as **Exhibit I**. The City accepts such warranties as submitted on the effective dates referenced therein.

(b) With the exception of the Tecta Warranty claims referenced in Section 3(e) above, the City's sole recourse for any warranty claims shall be the subcontractor, installer, and/or manufacturer warranties referenced in Section 10(a) above. If not already titled to the City, the City may request that Clark use commercially reasonable efforts to assign warranties that exist and can be assigned to the City, or otherwise modified, so the City may directly pursue warranty claims without the assistance of Clark. Clark shall have no responsibility to submit, facilitate, or prosecute the City's warranty claims.

11. **Certified Cost of the City**. The City and Clark agree that Clark has satisfied its obligations under Section 11.15 of the CMaR Agreement.

12. **Completion of Work**. Other than the Remaining Project Obligations and Low Voltage Items, identified in Sections 3 and 5 above, or latent defects, the City agrees that all other work Clark is required to perform under the CMaR Agreement is complete, including but not limited to, the provision of submittals and close out documentation to the City and all obligations relating to its obligations pursuant to Article 2 of the CMaR Agreement, unless otherwise expressly stated in this Agreement. The Parties intend for this Agreement to resolve all disputes regarding the status of any alleged non-conforming work ("NCRs"), punchlist items, and warranty claims unless specifically addressed herein. Except for latent defects, and other than the items specifically listed in this Agreement, Clark shall have no further responsibility or obligation with respect to any work or claims relating to NCRs, punchlist items, or warranty claims.

13. **Dismissal of the Action**. Within five (5) business days following the Effective Date, the Parties shall file a joint stipulation to dismiss the Action, *with prejudice*, with each party to bear their own fees and costs with the court reserving jurisdiction to enforce the terms of this Agreement subject to Section 18 below.

14. **Audit Rights**. The City waives its proprietary, inspection and audit rights under the CMaR Agreement, including, but not limited to, any such rights contained in Sections 2.1.5, 6.4, and Article 16 to the extent allowable pursuant to applicable law. Any audit obligations to other government agencies, including Miami-Dade County, regulatory bodies or as required by ordinance or statute shall survive the execution of this Agreement.

15. **City Commission Approval**. This Agreement is subject to and conditioned upon the Mayor and City Commission of the City of Miami Beach (collectively, the "Commission") holding a closed-meeting held pursuant to Fla. Stat. 286.011(8) ("Closed Meeting") and the adoption for a resolution authorizing and approving the Agreement ("Resolution"). The Closed-Meeting shall be held on Friday, September 17th, 2021, at which time City staff and counsel shall

127294236.1
127294236.v1

 ARS

recommend acceptance of this Agreement. The Resolution for the Settlement Agreement shall be presented to the Commission on Thursday, September 30, 2021, at which time the Commission will vote on the adoption of the Resolution. City staff and counsel shall recommend acceptance of this Agreement to the Commission. In the event the Commission does not approve the Agreement at the Closed Meeting, the City shall notify Clark immediately following the conclusion of the Closed Meeting, and the trial for the Action shall recommence on Monday, September 20, 2021. In the event the Commission does not approve the Resolution at the September 30, 2021 public meeting, this Agreement shall automatically become null and void immediately following the public meeting, and the trial for the Action shall recommence on Monday, October 1, 2021.

16. **Mutual General Releases**

(a) In consideration of the foregoing, Clark, its successors, affiliates, and assigns, do hereby release, waive, and discharge all rights, causes of actions, liabilities and claims, in law or in equity, whether known or unknown, whether foreseen or unforeseen, whether or not hidden or concealed, whether based on tort, intentional tort, fraud, contract, contribution or otherwise, and/or any other obligations, claims, damages, interests, or debts of any kind (“**Claims**”) relating to the Project and the CMaR Agreement and the OR Agreement that Clark ever had, could have asserted or have been asserted in the Action against the City and Hill, their agents, officers, members, managers, directors, shareholders, partners, parents, affiliated and sibling companies, members, limited partners, general partners, employees, attorneys, successors, insurers and assigns (the “**City and Hill Releasees**”), which Clark, from the beginning of time to the Effective Date, possessed or may possess against the City and Hill Releasees, except for the rights, duties and obligations arising under this Agreement.

(b) In consideration of the foregoing, and subject to the limitations as set forth below, the City, its successors, affiliates, and assigns, do hereby release, waive, and discharge all Claims relating to the Project and the CMaR Agreement and the OR Agreement that the City ever had, could have asserted or may have been asserted in the Action against Clark and its subcontractors, their agents, officers, managers, insurers, directors, shareholders, partners, parents, affiliated and sibling companies, members, limited partners, general partners, employees, successors, insurers and assigns (collectively, the “**Clark Releasees**”), which the City, from the beginning of time to the Effective Date, possessed or may possess against the Clark Releasees, except for the rights, duties and obligations arising under this Agreement. Notwithstanding anything to the contrary herein contained, the City does not release Clark or its subcontractors for claims relating to or arising from latent construction defects at the Project of which the City, and its agents, including but not limited to, Hill and Spectra, or any of their successors, affiliates or assigns is unaware at the Effective Date.

In consideration of the foregoing, and subject to the limitations to the City’s release set forth in the preceding paragraph the City, its successors, affiliates, and assigns, further release, waive, and discharge all Claims relating to the Project, the CMaR Agreement, and the Bond that were asserted or that may have been asserted in the Action against the Sureties, their agents, officers, members, directors, shareholders, partners, parents, affiliated and sibling companies, members, limited partners, general partners, employees, successors, and assigns (collectively, the

127294236.1
127294236.v1

 ARS

“Surety Releasees”), which the City, from the beginning of time to the Effective Date, possessed or may possess against the Surety Releasees.

(c) In consideration of the foregoing, Hill, its successors, affiliates, and assigns, do hereby release, waive, and discharge all Claims relating to the Project and the CMAr Agreement and the OR Agreement that Hill ever had, could have asserted or may have been asserted in the Action against the Clark Releasees and Surety Releasees, which Hill, from the beginning of time to the Effective Date, possessed or may possess against the Clark Releasees and Surety Releasees.

(d) In consideration of the foregoing, the City and Hill hereby mutually release, waive and forever discharge each other from all Claims relating to the Project, the CMAr Agreement and the OR Agreement that were asserted or could have been asserted against each other, their agents, officers, managers, directors, shareholders, partners, parents, affiliated and sibling companies, members, limited partners, general partners, employees, attorneys, successors, insurers and assigns in the Action, including, but not limited to, any claims for contractual indemnity under the OR Agreement, and any claims against each other for reimbursement of attorneys’ fees, expert fees, costs, and other litigation expenses that either the City or Hill incurred as a result of the Complaint, Counterclaim or Third-Party Complaint.

17. **Default Notices.** Any Party may issue a Notice of Default based on another Party’s failure to meet its obligations under the terms of this Agreement, and nothing contained herein shall limit the Parties’ right to issue such notice, so long as such notice is consistent with this Agreement’s terms.

18. **Disputes/Enforcement:**

(a) Subject to Section 18(b) below, this Court, through Private Judge the Honorable John W. Thornton (Ret.) shall retain jurisdiction of the Action, pursuant to the Agreed Order Granting Joint Application for Voluntary Trial Resolution Pursuant to Fla. Stat. Section 44.104, for the purpose of enforcing the terms of this Agreement, including enforcing decisions and findings of the Decision-Maker, and resolving any disputes regarding performance thereunder subject to Section 18(b) below. All references to the “Court” throughout this Agreement refer to Judge Thornton in his capacity as voluntary trial resolution judge. The Parties agree to waive any appellate rights with regard to Judge Thornton’s ruling on any dispute. In the event Judge Thornton is unable or unwilling to continue his role as voluntary trial resolution judge, the Parties shall work together in good faith to select a replacement voluntary trial resolution judge to resolve any disputes as provided herein. If the Parties are unable to come to an agreement, the Action shall revert to the Complex Business Division of the Eleventh Judicial Circuit in and for Miami-Dade County, and the Parties shall ask the assigned Judge to select a replacement Private Judge to oversee the enforcement of this Settlement Agreement.

(b) If the Parties have a dispute concerning the work performed or deliverables submitted under this Agreement, the Parties shall submit the dispute to the Decision-Maker for determination. **All determinations and findings of the Decision-Maker shall be binding and final and shall not be subject to any form of judicial review or modification.** The Court’s sole

AK *ARS*

role with respect to such decisions shall be enforcement of this Agreement based on the Decision-Maker's findings.

(c) In the event a Party brings a dispute before Judge Thornton or the Decision-Maker, excluding a request to certify completion of work in accordance with Sections 4(b) or 4(c) above, the prevailing party shall be entitled to its reasonable attorney's fees and costs. The Parties agree to waive any appellate rights with regard to Judge Thornton's or the Decision-Maker's ruling on any dispute. The Parties agree that in the event that the Decision-Maker orders Clark to specifically perform any of its Remaining Project Obligations but Clark fails to undertake any efforts to perform that work within thirty (30) days of the applicable ruling, the maximum amount of monetary damages the Court may award the City is the lesser of: (i) double the cost of completing the subject work, or (ii) the amount of the Performance-Based Payment associated with the Remaining Project Obligation that Clark failed to perform.

19. **Confidentiality.**

(a) In consideration of the obligations under this Agreement, and subject to the obligations of the City under the Florida Public Records Act and similar statutes, laws and regulations, the Parties agree that this Agreement and the terms and conditions hereof are strictly, and shall forever remain, confidential, and that no Party shall disclose or disseminate any information concerning any such terms to any third person(s), including, but not limited to, representatives of the media, except that Parties may disclose the terms of this Agreement to their respective attorneys, accountants, tax advisors, other similar professional or the Internal Revenue Service or other appropriate federal agencies, ("**Third Parties**") and as required by Florida's Public Records Law. All Third Parties to whom such disclosure is made shall agree in advance to be bound by the terms of this Section 19. Notwithstanding the foregoing, Clark may share this Agreement with any of its subcontractors who performed work on the Project with no obligation to so notify the City or Hill pursuant to Section 18(b), below.

20. **Non-Disparagement.** Except as required by law, all Parties agree that they shall not engage in any conduct or make any statement that is in any way critical of, or disparaging to, or otherwise derogatory about any of the other Parties or any of the Parties' services, business practices, business affairs or financial condition, or any of the Parties' owners, members, directors, officers, employees, agents or representatives. The Parties understand and agree that their commitment not to defame, disparage, or impugn the other Parties' reputations may constitute a willing and voluntary waiver of their rights under the First Amendment of the United States Constitution and other laws. However, these non-disparagement obligations do not limit the Parties' ability to truthfully communicate with any governmental agency, whether such communication is initiated by the Party or in response to the government

SPC *ARS*

21. Miscellaneous.

(a) Amendment. The terms and provisions of this Agreement may not be amended, modified or supplemented orally or by course of conduct or course of dealing, but only in a writing authorized, approved, and signed by each of the Parties.

(b) Waivers. The failure of a Party to require performance of any provision of this Agreement shall in no manner affect its right at a later time to enforce such provision. No waiver by a Party of any condition or of any breach of any term, covenant, representation or warranty contained in this Agreement shall be effective unless in writing, and no waiver in any one or more instances shall be deemed to be a further or continuing waiver of any such condition or breach in other instances or a waiver of any other condition or breach of any other term, covenant, representation or warranty.

(c) Consequential Damages Waiver. IN NO EVENT SHALL EITHER PARTY BE LIABLE FOR ANY LOSS OF PROFIT, INDIRECT, INCIDENTAL, SPECIAL, PUNITIVE, OR CONSEQUENTIAL DAMAGES ARISING OUT OF OR RELATING TO THIS AGREEMENT.

(d) Counterparts. This Agreement may be executed in one or more counterparts, or by the Parties in separate counterparts, each of which when so executed shall be deemed an original, but all of which together shall constitute one and the same instrument. Delivery of an executed counterpart of this Agreement by electronic .pdf format (non-modifiable) or telecopier shall have the same force and effect as delivery of an original executed counterpart of this Agreement.

(e) Interpretation. The headings preceding the text of Sections included in this Agreement are for convenience only and shall not be deemed part of this Agreement or be given any effect in interpreting this Agreement. None of the Parties shall be considered the draftsman of this Agreement, and there shall be no presumption of construing ambiguities or interpretations under this Agreement against a particular Party. In the event of any conflict between this Agreement and the CMaR Agreement, this Agreement shall control.

(f) Non-Admission. Nothing in this Agreement, including the above Settlement Sum, is to be construed as an admission of wrongdoing or of any liability by any Party. Each Party acknowledges and agrees that this Agreement represents a settlement and compromise reached between the Parties. The execution of this Agreement shall not be deemed, construed or interpreted, in any way, to be an admission by any Party regarding liability, damages, or the validity of any claim or defense which any Party has asserted or may assert. If this Agreement is not fully and finally consummated by its valid and binding execution date, then no statements contained herein shall be used for any purpose whatsoever against any Party

(g) Applicable Law. This Agreement shall be governed by and construed and enforced in accordance with the internal laws of the State of Florida without giving effect to the principles of conflicts of law thereof.

ARC
ARS

(h) Assignment. This Agreement shall be binding upon and inure to the benefit of the Parties and their respective estates, heirs, legal representatives, successors and assigns; provided, however that no assignment or transfer of this Agreement shall be permissible except by (i) operation of law, or (ii) pursuant to an order of a court of law. Each Party represents and warrants that no other person or entity, except their respective professionals, has or has had any interest in the claims, demands, obligations or causes of action referred to in this Agreement, except as otherwise set forth herein, and that it has not sold, assigned, transferred, conveyed, or otherwise disposed of any of the claims, demands, obligations or causes of action referred to in this Agreement.

(i) Severability. If any provision of this Agreement shall be held invalid, illegal or unenforceable, the validity, legality or enforceability of the other provisions of this Agreement shall not be affected, and there shall be deemed substituted for the provision at issue a valid, legal and enforceable provision as similar as possible to the provision at issue.

(j) Jurisdiction and Venue. The Parties agree that the Court in the Action, presently the Honorable John W. Thornton (Ret.), shall have exclusive jurisdiction to enforce and construe the provisions of this Agreement in accordance with Section 18(a). The Parties consent to the exercise of personal and subject matter jurisdiction therein to adjudicate any such litigation, and waive any and all personal and subject matter jurisdiction defenses and waive any rights it may have to a trial by jury arising out of or relating to any dispute under this Agreement.

(k) Advice of Counsel. Each Party to this Agreement represents and warrants that it has consulted with competent counsel of their choosing in connection with this Agreement and prior to signing it, or that each Party has had the opportunity to consult with competent counsel of their choosing prior to signing this Agreement and has voluntarily relinquished the right to do so.

(l) Entire Agreement. This Agreement represents and contains the entire agreement and understanding among the Parties hereto with respect to all issues raised or that could have been raised regarding the subject matter of this Agreement, with the exception of the contemporaneously executed Supplemental Agreement between Clark and Hill. Each of the Parties acknowledges and agrees that there are no written or oral communications or understandings contrary, different, or that in any way restrict this Agreement and all prior agreements or understandings within the scope of the subject matter of this Agreement are superseded in all respects and are null and void upon the execution of this Agreement. The Parties agree they will make no claim and waive any right they may have now or may have hereafter based upon any alleged oral alteration, amendment, modification or any other alleged change in this Agreement.

(m) Authority. The individuals executing this Agreement in a representative capacity expressly represent and warrant that they are fully authorized and empowered to execute this Agreement on behalf of the Party on whose behalf they are signing, and each Party represents that no other persons, entities or parties in interest are required to execute this Agreement in order to effectuate the purpose and intent of this Agreement.

AKS
AKS

CLARK CONSTRUCTION GROUP, LLC v. THE CITY OF MIAMI BEACH, FLORIDA, ET AL.
Settlement and Release Agreement
Page 15 of 17

(n) Notice. All notices required or permitted to be given under this Agreement shall be in writing and shall be deemed delivered when personally delivered, received from an overnight delivery courier service, or emailed to the applicable addresses as follows:

If to Clark:

Rick Yezzi
Clark Construction Group, LLC
7500 Old Georgetown Road, Bethesda, MD 20814
rick.yezzi@clarkconstruction.com

With a copy to:

Legal Department Attn: Jay Cox
Clark Construction Group, LLC
7500 Old Georgetown Road, Bethesda, MD 20814
jay.cox@clarkconstruction.com and
legalreviews@clarkconstruction.com

If to the City:

City Manager
City of Miami Beach
1700 Convention Center Dr.
Miami Beach, FL 33139
Alinahudak@miamibeachfl.gov

With a copy to:
City Attorney

City of Miami Beach
1700 Convention Center Dr.
Miami Beach, FL 33139
Rafaelpaz@miamibeachfl.gov

Lu Prats, Esq.
Carlton Fields
4221 W. Boy Scout Blvd
Tampa, Florida 33607
lprats@carltonfields.com

If to Hill

~~Karen Deshon, Senior Project Manager~~
~~Hill International, Inc.~~
~~1901 Convention Center Drive~~
~~Miami Beach, FL 33139~~
~~karendeshon@hillintl.com~~

With a copy to:

~~Aileen Schwartz, SVP, Senior Corporate Counsel US + Privacy Officer~~
~~Hill International, Inc.~~
~~2005 Market Street 17th Floor~~
~~Philadelphia, PA 19103~~
~~aileenschwartz@hillintl.com~~

CLARK CONSTRUCTION GROUP, LLC v. THE CITY OF MIAMI BEACH, FLORIDA, ET AL.
Settlement and Release Agreement
Page 16 of 17

[signature page to follow]

127294236.1
127294236.v1

Handwritten initials 'MA' and 'ab' in the bottom right corner.

CLARK CONSTRUCTION GROUP, LLC v. THE CITY OF MIAMI BEACH, FLORIDA, ET AL.
Settlement and Release Agreement
Page 17 of 17

IN WITNESS WHEREOF, the Parties hereto have caused this Agreement to be executed and delivered as of the later date set forth below.

CLARK CONSTRUCTION GROUP, LLC THE CITY OF MIAMI BEACH, FLORIDA

By: 

By: _____

Print Name: GREGORY S. COLEVAS

Print Name: _____

Title: DIV. PRES. + CEO

Title: _____

Date: 9-10-2021

Date: _____

HILL INTERNATIONAL, INC.

By: Aileen Schwartz

Print Name: Aileen Schwartz

Title: SVP, Senior Corporate Counsel US + Privacy Officer

Date: 9/20/2021

APPROVED AS TO
FORM & LANGUAGE
& FOR EXECUTION

City Attorney Date

RFI Response Follow-Up

EXHIBIT A

Miami Beach Convention Center

4/20/2021

General Revisions to the [REV S] Drawings Dated 04.06.21

Discipline & Item No. Sheet or Specification Section Drawings: All revisions, additions, deletions indicated by clouds or delta. Specifications: All revisions, additions, deletions indicated by tracked changes.

Reason for Change	Discipline & Item No.	Sheet or Specification Section	Drawings
Field Condition	08 Structural - S S 1	Rev S - SCS INT Rev 18	24" HDPE Equalizer Line Support
Field Condition	15 Mechanical - M E 1	M3002	Cooling tower modifications
Field Condition	E 2	M7000	Cooling tower modifications

PROJECT: MIAMI BEACH CONVENTION CENTER RENOVATION & EXPANSION	REVISION DATE: 04.08.21	PROJECT #: 20140021
ISSUED FOR: SCS INT REV 18	DETAIL #: NA	SHEET #: NA
DATE: 04.08.21	SCALE: N.T.S.	SKETCH LOCATION:

FENTRESS
ARCHITECTS

DRAWING TITLE: 24" HDPE EQUALIZER LINE SUPPORT

SKETCH NUMBER:
Rev S - SCS
INT Rev 18

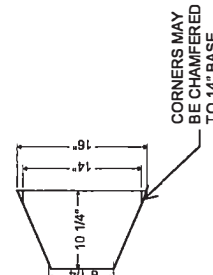
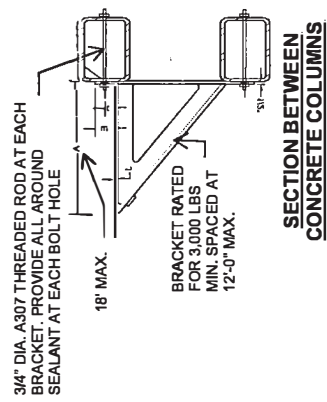

(2) ROWS OF (3) 3/4" DIA. A307 THREADED RODS EMBED 12" INTO (E) CONCRETE COLUMN WITH SIMPSON SET-XP ADHESIVE. FIELD LOCATE REBAR PRIOR TO DRILLING. NOTIFY EOR OF REBAR CONFLICTS PRIOR TO FINAL INSTALLATION

LOCATION OF EQUALIZER LINE SUPPORT GIRTS ON NORTH FACE OF (E) CONCRETE COLUMNS

AT EXP. JT. (SEE SATELLITE IMAGE FOR LOCATION) COLUMN IS SEPARATED INTO (2) 18"x23.5" COLUMNS

SECTION OCCURS AT TOP GIRT AND BOTTOM GIRT

SECTION TOP & BOT.

(E) 18"x48" CONCRETE COLUMN

SECTION BETWEEN CONCRETE COLUMNS

PLAN VIEW

HSS 10x6x5/16 (LLH) GIRTS CENTERED ON UPPER AND LOWER BOLT HOLES OF WELDED PIPE BRACKET

(E) 18"x48" CONCRETE COLUMN

NOTE: EMBED OCCURS AT UPPER AND LOWER GIRTS

ELEVATION

ELEVATION

SECTION

EMBED PL. 5/8"x14"x1/4"

MATCH COOLING TOWER FRAMING COATING REQUIREMENTS. RE: SPECS Page 376 of 446

FIELD LOCATE REBAR PRIOR TO DRILLING. NOTIFY EOR OF REBAR CONFLICTS

*ALL WELDS TYP. WELDS MAY BE SHOP WELDS AT CONTRACTOR'S OPTION

Warning: It is a violation of the law for any person, unless acting under the direction of a licensed architect, to alter an item in any way. If an item in this document is altered, the altering architect, if other than the architect of record, shall file in the item his seal and the notation "altered by" followed by his signature and the date of such alteration, and the specific description of the alteration.

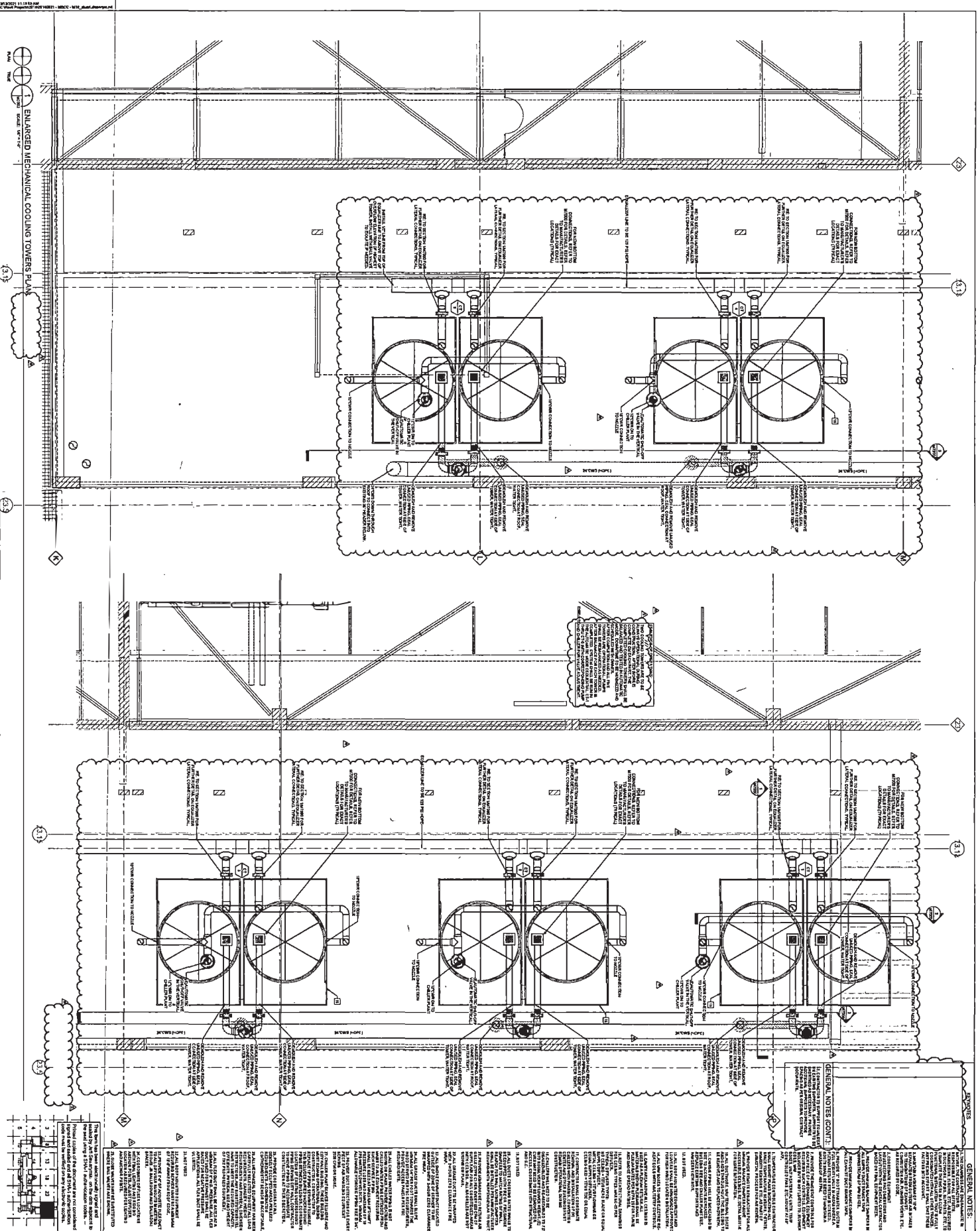

MIAMI BEACH CONVENTION CENTER RENOVATION

1901 CONVENTION CENTER DRIVE
MIAMI BEACH, FL 33139



FENTRESS ARCHITECTS

M3002

MECHANICAL

ENLARGED MECHANICAL COOLING TOWERS PLAN

DATE: 11/11/11

SCALE: 1/4" = 1'-0"

PROJECT: MIAMI BEACH CONVENTION CENTER RENOVATION

CLIENT: MIAMI BEACH CONVENTION CENTER

DESIGNER: FENTRESS ARCHITECTS

DATE: 11/11/11

ATTACHMENT A

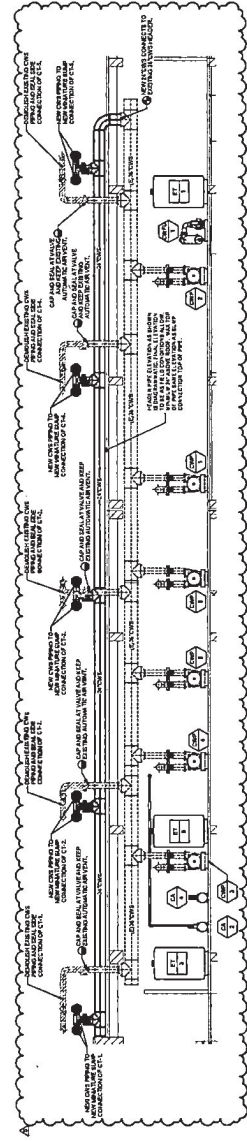
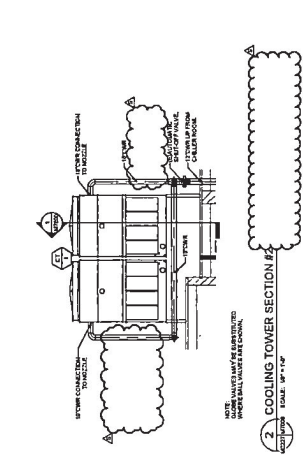
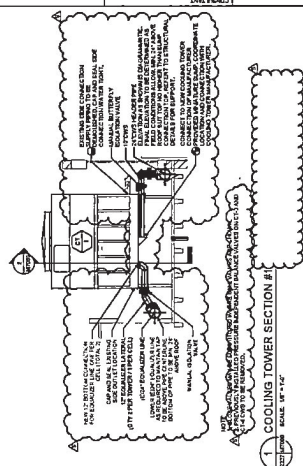

3 CONDENSER WATER SUPPLY HEADER

MANUFACTURER'S DETAILS FOR REFERENCE

MANUFACTURER: MARLEY
 MODEL: 1901-01-01-01
 DATE: 07/07/2018

SECTION: 1
 SCALE: 1/4" = 1'-0"

NOTE: ALL UNITS ARE TO BE SUBMITTED TO THE MANUFACTURER FOR APPROVAL.

MANUFACTURER'S DETAILS FOR REFERENCE

MANUFACTURER: SPX
 MODEL: 1901-01-01-01
 DATE: 07/07/2018

SECTION: 1
 SCALE: 1/4" = 1'-0"

NOTE: ALL UNITS ARE TO BE SUBMITTED TO THE MANUFACTURER FOR APPROVAL.

MANUFACTURER'S DETAILS FOR REFERENCE

MANUFACTURER'S DETAILS FOR REFERENCE

MBCC Legend	Firm	Details	Textive	Request	Priority	Move-In/Out Days	Room	No Events
DAY OF MONTH								
DAY OF WEEK								
Hall A	FIME		Supercon				Associated Builders & Contractors Showcases	
Hall B								Seaside
Hall C								
Hall D								
Grand Ballroom							2021 International Floriculture Expo	
Ocean Drive	FIME						MBCC Gala	
Lincoln Road							2021 International Floriculture Expo	
Art Deco								
East Rooms								
West Rooms	FIME						2021 International Floriculture Expo	
Sunset Vista	MB Tank Force						2021 International Floriculture Expo	
							Parks & Rec Welcome Back Event	CMD Commission
DAY OF MONTH								
DAY OF WEEK								
Hall A			Jeweler's International showcases				Miami International Auto Show	
Hall B	Seaside							
Hall C								
Hall D			JUMP Dance Conv.				Miami Heat Flooring	Cruise Ship Interiors Expo
Grand Ballroom			World Molecular Imaging Society				MB Condo & HOA	LOBTQ Tank Force Gala
Ocean Drive			Jeweler's International showcases				Miami International Auto Show	
Lincoln Road			JUMP Dance Conv.					Cruise Ship Interiors Expo
Art Deco			Econ.					
East Rooms			World Molecular Imaging Society					
West Rooms			JUMP Dance Conv.					
Sunset Vista			Jeweler's International showcases				Miami International Auto Show	Le Miami
								CMD Fire Entry Exam
DAY OF MONTH								
DAY OF WEEK								
Hall A			AAP Annual Meeting					
Hall B			AAP Annual Meeting					
Hall C			Le Miami					
Hall D			International Congress of Esthetics & Spa					
Grand Ballroom			AAP Annual Meeting				CruiseWorld	Art Basel
Ocean Drive			AAP Annual Meeting				CruiseWorld	
Lincoln Road			Le Miami					
Art Deco			AAP Annual Meeting					
East Rooms			AAP Annual Meeting				CruiseWorld	
West Rooms			Le Miami				Food Company Address	
Sunset Vista			AAP Annual Meeting				International Congress of Esthetics & Spa	
								ITC
DAY OF MONTH								
DAY OF WEEK								
Hall A			Art Basel				Carchella	IndEx 2021
Hall B								IndEx 2021
Hall C								IndEx 2021
Hall D								IndEx 2021
Grand Ballroom								IndEx 2021
Ocean Drive								IndEx 2021
Lincoln Road								IndEx 2021
Art Deco								IndEx 2021
East Rooms								IndEx 2021
West Rooms								IndEx 2021
Sunset Vista								IndEx 2021
DAY OF MONTH								
DAY OF WEEK								
Hall A			Build Expo USA				Original MB Antique Show	58th STS Annual Meeting
Hall B							Original MB Antique Show	58th STS Annual Meeting
Hall C							Jeweler's Internat	58th STS Annual Meeting
Hall D							Jeweler's Internat	58th STS Annual Meeting
Grand Ballroom			NO EVENTS				Advanced Therap	58th STS Annual Meeting
Ocean Drive							Original MB Antique Show	58th STS Annual Meeting
Lincoln Road							Jeweler's Internat	58th STS Annual Meeting
Art Deco								Advanced Therap
East Rooms								58th STS Annual Meeting
West Rooms								58th STS Annual Meeting
Sunset Vista							Jeweler's Internat	58th STS Annual Meeting
DAY OF MONTH								
DAY OF WEEK								
Hall A							International Yacht and Boat Show	
Hall B							International Yacht and Boat Show	
Hall C			Natural Disaster				International Yacht and Boat Show	
Hall D			Natural Disaster				International Yacht and Boat Show	
Grand Ballroom			Miami Marathon & Half				International Yacht and Boat Show	
Ocean Drive			United Way				International Yacht and Boat Show	
Lincoln Road			Natural Disaster				International Yacht and Boat Show	
Art Deco							International Yacht and Boat Show	
East Rooms							International Yacht and Boat Show	
West Rooms							International Yacht and Boat Show	
Sunset Vista			Miami Marathon & Half				International Yacht and Boat Show	
							Babson Co	International Yacht and Boat Show

EXHIBIT C

Miami Beach Convention Center Flex Duct

9/8/2021

BIM #	Description	Location
20765	At 28 locations throughout Grand Ballrooms A, B and C the flexible duct has separated from the hard duct. Exact locations are shown in attachment in BIM360 dated June 25, 2021	Grand Ballroom A/B/C

EXHIBIT D

9/8/2021

Miami Beach Convention Center Skimmers List

ID	Description	Location Path
1	Install Skimmer S-14	Convention Center Drive
2	Install Skimmer S-12	Convention Center Drive
3	Repair Skimmer D-18	21st Street Park

EXHIBIT E

Miami Beach Convention Center Light List

9/8/2021

BIM # / ID #	Description	Location
18173	The LP7 light fixtures are not installed at any of the north stalls, with the exception of the northwest. As mentioned in other comments, the lenses are not installed at any of the stalls as well.	RESTROOMS>4.29.15 - PUBLIC RESTROOM - TYPE A
17403	Work is incomplete on all the L20 light fixtures.	1.28.08 - Loading Elevated Circulation
20189	Replace light near banyan tree	Site>NorthEast
16322	The lights installed between the stalls do not appear to be of the correct LP23 type. The plans call for five of these fixtures yet three of the alternate are installed instead.	RESTROOMS>2.04.05 - PUBLIC RESTROOM - TYPE A
13681	The LP33A-DIM light fixture at the east meeting rooms curved soffit is not installed and/or working.	CIRCULATION PUBLIC>2.28.01 - PUBLIC CONCOURSE
10624	The LP3B-DIM light fixtures on the columns east of grid Q.8 don't turn on.	CIRCULATION PUBLIC>2.03.01 - BALLROOM PREFUNCTION
16480	The fire rated sleeve next to door 2.07.26 is not installed	MEETING ROOM>2.07.11 - MEETING ROOM 4
15645	The LP7 light fixtures in the women's restroom stalls need to be installed and completed	RESTROOMS>4.29.15 - PUBLIC RESTROOM - TYPE A
16323	The lens covers are not installed at any of the LP7 light fixtures.	RESTROOMS>2.04.05 - PUBLIC RESTROOM - TYPE A
12087	None of the LP2-DIM light fixtures are installed at the east soffit.	MEETING ROOM>1.30.17 - MEETING ROOM 4
13531	None of the lighting trim kits between grids 23.73 & 23.1 are installed. This issue affects about 19 lights.	CIRCULATION PUBLIC>2.30.12 - MEETING ROOM PREFUNCTION
18597	The D6-DIM light fixture above the sink is not installed.	RESTROOMS>2.06.12 - TOLIJET 2
16367	None of the LP7 light fixtures are installed.	RESTROOMS>2.04.03 - PUBLIC RESTROOM - TYPE A
18171	The lenses for the LP7 light fixtures are not installed at any of the stalls.	RESTROOMS>4.29.15 - PUBLIC RESTROOM - TYPE A
18581	The two west light switches on the north wall don't control anything.	BACK OF HOUSE>2.06.09 - VIP SUITE
13756	The light fixture at portals 2.29.04 & 2.29.26 are not installed.	CIRCULATION PUBLIC>2.28.08 - MEETING ROOM PREFUNCTION
14518	The lighting underneath the cabinet is not installed.	OPERATIONS>2.14.03 - STAFF BREAK ROOM
20	Issue with Touch Screen at C, MC Dean and Cooper Lighting to Address	Lincoln Ball Room
44	West lobby 1st and 2nd lights will dim but won't turn off. MC Dean investigated and could not find problem. MC Dean and Cooper Lighting to Address	Lobbies
28	Sunset A levels not changing. MC Dean investigated and could not find problem. MC Dean and Cooper Lighting to Address	Sunset Ballroom
24	LP5 fixtures require DMX controls (need direction from ME). MC Dean stated this has been confused with Starry Night fixtures which have been deleted, to confirm with Cooper Lighting	Sunset Ballroom
3	This applies to all Ballrooms, are controls to automate partitioning? ME Comment 04.09.21: For the ballrooms, the documents require the lighting groups be controllable based on the wall positions. This does not necessarily require wall position sensors as long as the program includes grouping of like light fixture types together for all possible wall configurations. Further, lighting control for all possible wall configurations shall be available and selectable from the touchscreen wall controllers. MC Dean and Cooper to confirm work has been installed per ME's comment	Ocean Ballroom Level 1
39	LP 33-Dim to be controlled with DMX - MC Dean to verify it is completed	Grand Ballroom
40	Verify emergency power to lights in room	Grand Ballroom
19	E and F need Touch screens troubleshot / mounted	Lincoln Ball Room
82	Entry Lights - Room 216 OK. Room 221 light is installed and has power. Cooper issue.	216-221
80	2 room entrances missing lights and covers (224- Rm. 2.29.15), (225 is Rm 2.29.15) 1 missing just cover (226 is Rm.2.28.05) (227 is Rm.-2.28.06) entrance is ok.	224, 225, 226, 227

BIM # / ID #	Description	Location
9	Missing 2 LP 27	Ocean Ballroom Level 1
11	Waiting on 2 Ballast. MC Dean Temporarily disconnect for show on 4-07-21 at Spectra request	Lincoln Ball Room
1	Waiting on Ballast. MC Dean temporarily disconnected for show on 4-07-21 at Spectra request	Ocean Ballroom Level 1
8	Ongoing: one entry, top section out- Needs to be replaced. Second Entry just missing top section cover	Ocean Ballroom Level 1
22	Ongoing: Missing 5 - LP 27 and 6 - LP29 fixtures	Lincoln Ball Room
26	3 LP 24 lights missing. will notify his office and provide update.	Sunset Ballroom
35	DMX Controls, Fixtures need to have addresses match Channels. DMX control programmed into ilumin and building lighting control; Ballrooms B & C functioning but B partitioning to be done via GVA software; further troubleshooting for addressing and fixtures needed, particularly in Ballroom Av	Grand Ballroom
13	LP29-Dim, Some fixtures appear brighter than others, One set has yellow tint	Lincoln Ball Room

EXHIBIT F

Miami Beach Convention Center Tecta Warranty List

9/8/2021

ID	Description	Location Path
1	Warranty leak in roof	Area 1, Level 1 - Approx location 10' west of column line R and column line 3 intersection
2	Warranty leak in roof	Level 2 Service Corridor - Approx column line 10.52 & F
3	Warranty leak in roof	Level 4 Ramp - Approx column line 10.52 & F

EXHIBIT G

Miami Beach Convention Center Closeout List

9/13/2021

ID	Item	Description
1	Electrical As-Builts	Update submittal 260502-015.0 to remove references to "temporary power". include any changes made by approximately 60 RFIS and all field changes after 03/27/2019 and stamp drawings with "Final As Builts"

EXHIBIT H

Greg Colevas
Division President
Clark Construction Group, LLC
7500 Old Georgetown Road
Bethesda, MD 20814

Re: Miami Beach Convention Center Renovation and Expansion

Dear Mr. Colevas,

The renovation of the Miami Beach Convention Center included a complete demolition and reconstruction of the existing exhibit halls, meeting rooms, and pre-function and support spaces, as well as a 263,000 square foot (SF) expansion for a total of 1,435,859 SF. There are five ballrooms, two on the ground floor, two on the second level and a 20,000 SF glass rooftop ballroom with an open terrace on the 3rd level overlooking the park. The 60,000 SF Grand Ballroom was added as part of the building addition. This is the largest ballroom south of Orlando. All new mechanical, electrical, and plumbing systems were installed, 796 new parking spaces were added, and significant improvements were made to the facility's façade, landscaping, and adjacent streets. The convention center achieved LEED Silver certification and there were 5 public art projects through the city's Art in Public Places program installed within the facility and adjacent grounds.

Clark Construction Group, LLC, the construction manager at risk for the project, delivered this technically and logistically complex project. In addition, the Miami Beach Convention Center remained open during construction to allow for planned conventions and meetings, both large and small, to take place while the facility was under renovation. Throughout construction the convention center was able to host more than 90 shows, including five Art Basel events, an important show for both the convention center and the local Miami Beach economy, the 2020 NFL Experience (Super Bowl LIV) and Major League Baseball "Fanfest". The team maintained an outstanding safety record with more than 5,000,000 worker hours without a lost time incident and provided more than 63% of the over 7,000 jobs to local workers.

The Miami Beach Convention Center is now a magnificent and technologically advanced facility that will meet the needs of our city and convention goers for years to come.

Sincerely,

City of Miami Beach

EXHIBIT I

Miami Beach Convention Center - Warranties

Kahua #	Spec Name	Submittal Category	Participant
017700-002.1	Closeout Requirements	General Warranty	Banker Steel Co., LLC
017700-003.1	Closeout Requirements	General Warranty	Brazos Urethane
017700-004.1	Closeout Requirements	General Warranty	Creative Sign Designs
017700-005.1	Closeout Requirements	General Warranty	Dash Door & Closer
017700-006.1	Closeout Requirements	General Warranty	David Allen Company, Inc.
017700-007.1	Closeout Requirements	General Warranty	The Duffy & Lee Carpet Company
017700-008.1	Closeout Requirements	General Warranty	Eugenio Painting Company
017700-009.1	Closeout Requirements	General Warranty	Florida Architectural Precast
017700-010	Closeout Requirements	General Warranty	Florida Blacktop
017700-011	Closeout Requirements	General Warranty	Hayward Baker
017700-012.1	Closeout Requirements	General Warranty	HJ Foundation Company
017700-013.1	Closeout Requirements	General Warranty	Hollywood Woodwork, LLC
017700-014.1	Closeout Requirements	General Warranty	Hufcor
017700-015.1	Closeout Requirements	General Warranty	ISEC, Inc. Eastern Division
017700-016.1	Closeout Requirements	General Warranty	Nash Mechanical, LLC
017700-017.1	Closeout Requirements	General Warranty	Robins & Morton Group
017700-018.1	Closeout Requirements	General Warranty	Rite Hite
017700-019.1	Closeout Requirements	General Warranty	Specified Architectural Systems
017700-020.1	Closeout Requirements	General Warranty	Superior Landscaping
017700-021.1	Closeout Requirements	General Warranty	Tate Ornamental, Inc.
017700-022	Closeout Requirements	General Warranty	Therma Seal Insulation Systems, Inc.
017700-023.1	Closeout Requirements	General Warranty	Trident Surfacing, Inc.
017700-024.1	Closeout Requirements	General Warranty	Tru Steel
017700-027.1	Closeout Requirements	General Warranty	Argyle Security
017700-028.1	Closeout Requirements	General Warranty	Ford Audio-Video Systems, LLC
017700-029.1	Closeout Requirements	General Warranty	Decon Environmental
017700-030.2	Closeout Requirements	General Warranty	Won-Door
017700-031	Closeout Requirements	General Warranty	American Fireproofing
017700-032	Closeout Requirements	General Warranty	Pro-Bel
017700-033	Closeout Requirements	General Warranty	Overhead Door
017700-034	Closeout Requirements	General Warranty	Apex
017700-035.1	Closeout Requirements	General Warranty	Lutron Electronics
017700-036.0	Closeout Requirements	General Warranty	Trex
017700-037.0	Closeout Requirements	General Warranty	Mardale
017700-038.0	Closeout Requirements	General Warranty	National Fire Protection
017700-039	Closeout Requirements	General Warranty	Harmon, Inc.
017700-040	Closeout Requirements	General Warranty	WPM Southern
017700-041	Closeout Requirements	General Warranty	East Coast Structures
017700-042	Closeout Requirements	General Warranty	Camarata Masonry
017700-043.0	Closeout Requirements	General Warranty	M C Dean, Inc.
017700-044.0	Closeout Requirements	General Warranty	Royce Integrated Solutions
017700-045	Closeout Requirements	General Warranty	C.S.E. Paving
017700-046.1	Closeout Requirements	General Warranty	Otis Elevator Company
017700-047	Closeout Requirements	General Warranty	Arazaa Brothers Corp
017700-048	Closeout Requirements	General Warranty	P&J Stripping
017700-050	Closeout Requirements	General Warranty	Homestead
017700-051	Closeout Requirements	General Warranty	Acousti Engineering Co of Florida
017700-052.0	Closeout Requirements	General Warranty	Tecta America South Florida
017700-053	Closeout Requirements	General Warranty	Honeywell International
070150.61-015	Roof Re-Coating	Manufacturers Warranty	Tecta America South Florida
070150.61-016	Roof Re-Coating	Warranty	Tecta America South Florida
071326-022	Self-Adhering Sheet Waterproofing	Special Warranty	Tecta America South Florida
071413-047	Hot Fluid-Applied Rubberized Asphalt Waterproofing	Special Warranty	Tecta America South Florida
071413-048	Hot Fluid-Applied Rubberized Asphalt Waterproofing	Special Warranty	Tecta America South Florida
074213.23-006	Metal Composite Material Wall Panels	Special Warranty	Tate Ornamental, Inc.
074213.23-007	Metal Composite Material Wall Panels	Special Warranty	Tate Ornamental, Inc.
075423-039	Thermoplastic Polyolefin (Tpo) Roofing	Special Warranty	Tecta America South Florida
075423-040	Thermoplastic Polyolefin (Tpo) Roofing	Special Warranty	Tecta America South Florida
077129-017.0	Manufactured Roof Expansion Joints	Special Warranty	Tecta America South Florida
079200-019.1	Joint Sealants	Manufacturers Warranty	Therma Seal Insulation Systems, Inc.
079200-020.1	Joint Sealants	Special Warranty	Therma Seal Insulation Systems, Inc.
079200-021	Joint Sealants	Manufacturers Warranty	Harmon, Inc.
079200-022	Joint Sealants	Special Warranty	Dash Door & Closer
079200-023	Joint Sealants	Manufacturers Warranty	Dash Door & Closer
079200-024	Joint Sealants	Special Warranty	Eugenio Painting Company
079200-025.0	Joint Sealants	Manufacturers Warranty	Eugenio Painting Company
079219-003	Acoustical Joint Sealants	Manufacturers Warranty	Acousti Engineering Co of Florida

Miami Beach Convention Center - Warranties

Kahua #	Spec Name	Submittal Category	Participant
079219-004	Acoustical Joint Sealants	Special Warranty	Acousti Engineering Co of Florida
081416-003	Flush Wood Doors	Special Warranty	Argyle Security
081416-004	Flush Wood Doors	Special Warranty	Hollywood Woodwork, LLC
083340-005.1	Overhead Coiling Smoke and Fire Curtains	Manufacturers Warranty	Specified Architectural Systems
083483-007.1	Elevator Door Smoke Containment System	Manufacturers Warranty	Specified Architectural Systems
084110-022	Storefront Glazing System	Special Warranty	Harmon, Inc.
084110-022	Storefront Glazing System	Special Warranty	Harmon, Inc.
084110-024	Storefront Glazing System	Special Warranty	Dash Door & Closer
084110-024	Storefront Glazing System	Special Warranty	Dash Door & Closer
084413-077	Glazed Aluminum Curtain Walls	Warranty	Harmon, Inc.
084413-078	Glazed Aluminum Curtain Walls	Special Warranty	Harmon, Inc.
084413-080.1	Glazed Aluminum Curtain Walls	Special Warranty	Harmon, Inc.
084413-080.1	Glazed Aluminum Curtain Walls	Warranty	Dash Door & Closer
085653-004	Security Windows	Special Warranty	Dash Door & Closer
087100-017	Door Hardware	Special Warranty	Harmon, Inc.
087100-017	Door Hardware	Special Warranty	Dash Door & Closer
087100-017	Door Hardware	Warranty	Dash Door & Closer
087100-017	Door Hardware	Warranty	Dash Door & Closer
087100-017	Door Hardware	Warranty	Argyle Security
088000-013	Glazing	Warranty	Dash Door & Closer
088000-016	Glazing	Warranty	Harmon, Inc.
088000-017	Glazing	Warranty	Harmon, Inc.
088000-018	Glazing	Warranty	Harmon, Inc.
088000-019	Glazing	Warranty	Harmon, Inc.
088000-020	Glazing	Warranty	Harmon, Inc.
088000-021.1	Glazing	Warranty	Dash Door & Closer
088113-002	Decorative Glass Glazing	Special Warranty	Hollywood Woodwork, LLC
088113-002	Decorative Glass Glazing	Special Warranty	Dash Door & Closer
088300-005	Mirrors	Special Warranty	Dash Door & Closer
095443-008	Stretched-Fabric Ceiling Systems	Special Warranty	Acousti Engineering Co of Florida
096813-014	Tile Carpeting	Special Warranty	The Duffy & Lee Carpet Company
097723-007	Fabric-Wrapped Panels	Special Warranty	Acousti Engineering Co of Florida
098433.13-005.1	Metal-Faced Sound-Absorbing Wall Units	Special Warranty	Acousti Engineering Co of Florida
098433-011	Sound-Absorbing Wall Units	Special Warranty	Acousti Engineering Co of Florida
101401-003	Exterior Signage	Warranty	Creative Sign Designs
102238-013.1	Operable Panel Partitions	Special Warranty	Hufcor
102239-009.1	Folding Panel Partitions	Special Warranty	Specified Architectural Systems
102600-009.0	Wall And Door Protection	Special Warranty	Mardale
102800-001	Toilet, Bath, And Laundry Accessories	Warranty	Mardale
102800-011.0	Toilet, Bath, And Laundry Accessories	Special Warranty	Mardale
105113-003.1	Metal Lockers	Special Warranty	Mardale
111233-007.0	Parking Gates	Warranty	Royce Integrated Solutions
111319-005	Stationary Loading Dock Equipment	Manufacturers Warranty	Rite Hite
114000-059	Closeout Requirements	General Warranty	Baring Industries
114000-059	Food Service Equipment	Warranty	Baring Industries
133423.16-004	Fabricated Control Booths	Special Warranty	Honeywell International
133429-008	Fabricated Engineered Structures	Special Warranty	Harmon, Inc.
133429-009	Fabricated Engineered Structures	Special Warranty	Harmon, Inc.
142100-031	Electric Traction Elevators	Manufacturers Warranty	Otis Elevator Company
142400-031	Hydraulic Elevators	Manufacturers Warranty	Otis Elevator Company
142713-010	Custom Elevator Cab Finishes	Special Warranty	Otis Elevator Company
143100-032.0	Escalators	Manufacturers Warranty	Otis Elevator Company
221123-002.1	Domestic Water Booster	Warranty	Nash Mechanical, LLC
221500-015.0	Compressed Air System	Warranty	Nash Mechanical, LLC
223000-037.0	Plumbing Equipment	Warranty	Nash Mechanical, LLC
223000-037.0	Plumbing Equipment	Warranty	Nash Mechanical, LLC
230502-006.1	Basic Mechanical Requirements	Warranty	Nash Mechanical, LLC
230900-015.0	Building Automation And Automatic Temperature Control System	Warranty	Honeywell International
233600-009.0	Air Terminal Units	Warranty	Nash Mechanical, LLC
233600-009.0	Air Handling Units With Coil	Warranty	Nash Mechanical, LLC
236416-007	Centrifugal Water Chillers	Warranty	Nash Mechanical, LLC
260913-002	Electrical Power Monitoring	Warranty	M C Dean, Inc.
260933-004.0	Central Dimming Controls	Warranty	M C Dean, Inc.
260943-022.0	Network Lighting Control	Manufacturers Warranty	M C Dean, Inc.
260943-022.0	Network Lighting Control	Warranty	M C Dean, Inc.
262213-012.0	Low Voltage Distribution Transformers	Manufacturers Warranty	M C Dean, Inc.
262500-013.0	Enclosed Bus Assemblies	Warranty	M C Dean, Inc.

Miami Beach Convention Center - Warranties

Kahua #	Spec Name	Submittal Category	Participant
263005-009	Utility Floor Boxes	Warranty	M C Dean, Inc.
263353-010.1	Static Uninterruptible Power Supply	Warranty	M C Dean, Inc.
264314-007.0	Surge Protective Device (Spd)	Warranty	M C Dean, Inc.
265113-026.0	Lighting Fixtures	Warranty	Trex
265113-028	Lighting Fixtures	Warranty	M C Dean, Inc.
281300-007	Access Control System	Warranty	Honeywell International
282300-023	Video Surveillance System	Warranty	Honeywell International
283111-034	Digital, Addressable Fire-Alarm System (Voice Evacuation)	Special Warranty	Honeywell International
313116-004	Termite Control	Special Warranty	Apex
321218-006	Crushed Shell Aggregate	Special Warranty	Superior Landscaping
328400-012	Irrigation Systems	Warranty	Superior Landscaping
329300-035	Plants And Planting	Warranty	Superior Landscaping
329300-036	Plants And Planting	Warranty	Arazoza Brothers Corp

THIS PAGE INTENTIONALLY LEFT BLANK

Resolutions - R7 |

MIAMI BEACH

COMMISSION MEMORANDUM

TO: Honorable Mayor and Members of the City Commission
FROM: Alina T. Hudak, City Manager and Rafael A. Paz, Acting
City Attorney
DATE: September 30, 2021

SUBJECT: A RESOLUTION OF THE MAYOR AND CITY COMMISSION OF THE CITY OF MIAMI BEACH, FLORIDA, APPROVING THE SETTLEMENT AGREEMENT BETWEEN CLARK CONSTRUCTION GROUP, LLC ("CLARK"), HILL INTERNATIONAL INC. ("HILL"), AND THE CITY OF MIAMI BEACH, FLORIDA ("SETTLEMENT AGREEMENT"), AS ATTACHED TO THE COMMISSION MEMORANDUM ACCOMPANYING THIS RESOLUTION, TO SETTLE THE LITIGATION STYLED AS CLARK CONSTRUCTION GROUP, LLC, VS. THE CITY OF MIAMI BEACH AND HILL INTERNATIONAL INC., ELEVENTH JUDICIAL CIRCUIT, CASE NO. 2020-002129 CA 01, IN CONNECTION WITH THE MIAMI BEACH CONVENTION CENTER REDEVELOPMENT PROJECT ("PROJECT"), AND AUTHORIZING THE CITY TO (1) RELEASE THE \$X MILLION IN RETAINAGE WITHHELD FROM PAY APPLICATIONS UNTIL CONTRACT COMPLETION, IN PAYMENT FOR WORK PERFORMED ON THE PROJECT; (2) APPROVE PAYMENT OF \$X MILLION WITHHELD AS LIQUIDATED DAMAGES FROM CLARK ON THE PROJECT PAY APPLICATIONS TO ACCOUNT FOR PROJECT-RELATED SCHEDULE DELAYS, IN PAYMENT FOR WORK PERFORMED ON THE PROJECT; AND (3) APPROVE PAYMENT OF AN ADDITIONAL TOTAL AMOUNT OF \$X MILLION, IN FULL SATISFACTION OF ALL PROJECT-RELATED CLAIMS ASSERTED BY CLARK AGAINST THE CITY, IN THE TOTAL AMOUNT OF \$X MILLION, INCLUDING, WITHOUT LIMITATION, EXTRA WORK AND CHANGE ORDERS, CLARK'S CLAIM FOR GENERAL CONDITIONS, AND SUBCONTRACTOR IMPACT CLAIMS; WITH THE TOTAL SETTLEMENT AMOUNTS TO BE PAID BY THE CITY IN THE FOLLOWING INSTALLMENT PAYMENTS TO CLARK: \$X MILLION ON OR BEFORE OCTOBER 15, 2021; \$X MILLION ON OR BEFORE DECEMBER 31, 2021; \$X MILLION ON OR BEFORE THE OUTSIDE DATE OF MAY 15, 2022; \$X MILLION ON OR BEFORE DECEMBER 31, 2022; AND \$X IN PERFORMANCE BASED PAYMENTS TIED TO THE COMPLETION OF THE REMAINING WORK MILESTONES AS SET FORTH IN THE SETTLEMENT AGREEMENT; AND FURTHER, AUTHORIZING THE CITY MANAGER AND CITY ATTORNEY TO TAKE THE NECESSARY AND APPROPRIATE STEPS FOR THE IMPLEMENTATION OF THE SETTLEMENT AGREEMENT, AND AUTHORIZING THE CITY MANAGER AND CITY CLERK TO EXECUTE THOSE DOCUMENTS

ATTACHMENT A
AND/OR AGREEMENTS NECESSARY TO EFFECTUATE THE
SETTLEMENT AGREEMENT CONSISTENT WITH THIS RESOLUTION.
(ITEM TO BE SUBMITTED IN SUPPLEMENTAL)

SUPPORTING SURVEY DATA

N/A

**Is this a "Residents Right
to Know" item, pursuant to
City Code Section 2-14?**

Yes

**Does this item utilize G.O.
Bond Funds?**

No

Legislative Tracking

Office of the City Attorney/Office of the City Manager



MEMORANDUM
(Revised)

TO: Honorable Chairman Jose "Pepe" Diaz
and Members, Board of County Commissioners

DATE: March 15, 2022

FROM: 
Gen Bonzon-Keenan
County Attorney

SUBJECT: Agenda Item No. 8(G)(1)

Please note any items checked.

- "3-Day Rule" for committees applicable if raised
- 6 weeks required between first reading and public hearing
- 4 weeks notification to municipal officials required prior to public hearing
- Decreases revenues or increases expenditures without balancing budget
- Budget required
- Statement of fiscal impact required
- Statement of social equity required
- Ordinance creating a new board requires detailed County Mayor's report for public hearing
- No committee review
- Applicable legislation requires more than a majority vote (i.e., 2/3's present ____, 2/3 membership ____, 3/5's ____, unanimous ____, CDMP 7 vote requirement per 2-116.1(3)(h) or (4)(c) ____, CDMP 2/3 vote requirement per 2-116.1(3)(h) or (4)(c) ____, or CDMP 9 vote requirement per 2-116.1(4)(c)(2) ____) to approve
- Current information regarding funding source, index code and available balance, and available capacity (if debt is contemplated) required

Approved _____ Mayor
Veto _____
Override _____

Agenda Item No. 8(G)(1)
3-15-22

RESOLUTION NO. _____

RESOLUTION APPROVING FIFTH AMENDMENT BETWEEN MIAMI-DADE COUNTY, CITY OF MIAMI BEACH, AND MIAMI BEACH REDEVELOPMENT AGENCY TO INTERLOCAL COOPERATION AGREEMENT DATED NOVEMBER 16, 1993; AND AUTHORIZING COUNTY MAYOR OR COUNTY MAYOR'S DESIGNEE TO EXECUTE THE FIFTH AMENDMENT AND EXERCISE ALL PROVISIONS CONTAINED THEREIN

WHEREAS, the Legislature of the State of Florida enacted the Community Redevelopment Act of 1969, which is presently codified in Part III of Chapter 163, Florida Statutes (the "Act"); and

WHEREAS, pursuant to the Act, a redevelopment plan must be adopted by the governing body to initiate redevelopment activities within the redevelopment area; and

WHEREAS, all powers arising through the Act are conferred upon counties with home rule charters; and

WHEREAS, on January 26, 1993, the Board of Miami-Dade County Commissioners (the "Board") adopted Resolution No. R-14-93, which among other things (i) found the area in the City of Miami Beach (the "City") bounded on the East by the Atlantic Ocean, on the North by 24th Street, on the West by West Avenue, and on the South by 14th Lane (the "Redevelopment Area") to be a "blighted area" within the meaning of Part III of Chapter 163, Florida Statutes, and (ii) delegated to the City, pursuant to Section 163.410, Florida Statutes, the power to (a) make findings and determine the Redevelopment Area to be a slum and/or blighted area, (b) make findings of necessity as to the rehabilitation, conservation, and/or redevelopment of the Redevelopment Area, (c) create a community redevelopment agency and delegate powers to the agency, or declare itself

as the agency with the power to exercise such powers assigned to the agency, and (d) initiate, prepare and adopt a plan of redevelopment and any amendments thereto, subject to the review and approval of the Board; and

WHEREAS, on February 3, 1993, the City adopted Resolution No. 93-20709 which established a community redevelopment agency (the “Miami Beach Redevelopment Agency” or the “Agency”), and declared the members of the City Commission as the members of the Agency; and

WHEREAS, on March 30, 1993, the Board adopted Resolution No. R-317-93, which among other things (i) adopted the Agency’s City Center/Historic Convention Village Redevelopment and Revitalization Area plan (the “Plan”), for the redevelopment and revitalization of the Redevelopment Area, and (ii) approved the Interlocal Cooperation Agreement, between Miami-Dade County (the “County”) and the City, dated and executed on November 16, 1993 (the “CRA Interlocal Agreement”); and

WHEREAS, on April 27, 1993, the Board enacted Ordinance No. 93-28, which created a City Center/Historic Convention Village Redevelopment and Revitalization Trust Fund (the “Trust Fund”), and provided a funding mechanism for implementing the Plan; and

WHEREAS, on September 9, 2003, the Board adopted Resolution No. R-889-03, which approved a First Amendment to the CRA Interlocal Agreement, whereby the Board delegated to the City the power to implement community policing innovations within the Redevelopment Area; and

WHEREAS, on July 27, 2004, the Board adopted Resolution No. R-958-04, which approved a Second Amendment to the CRA Interlocal Agreement, whereby (i) the County, City, and Agency agreed that the Agency would remit one and one-half percent (1.5%) of the tax

increment revenue paid to the Agency for said fiscal year to the County to defray administrative costs for oversight and processing Agency related items, after debt service and all other obligations related to the bonds or future indebtedness issued by the Agency and approved by the County was satisfied for the fiscal year, and (ii) the County approved the Agency's issuance of refunding bonds in an amount not to exceed a principal amount of \$101,090,000.00, to refinance all or a portion of the outstanding principal amount of bonds issued with respect to the Redevelopment Area; and

WHEREAS, on December 16, 2014, the Board adopted Resolution No. R-1110-14, which among other things approved the Third Amendment to the CRA Interlocal Agreement, approved the Amended Redevelopment Plan, extended the life of the Agency until 2044 and provided for the issuance of revenue bonds to fund the renovation of the Miami Beach Convention Center (the "Convention Center Project"); and

WHEREAS, the Board, through Resolution No. R-644-18, the City Commission, through Resolution No. 2018-30288, and the Agency, through Resolution No. 629-2018, also approved a Fourth Amendment to the CRA Interlocal Agreement (the "Fourth Amendment"), which, among other terms, recognized that the available revenues remaining on deposit in the Trust Fund, as of the Agency's year-end for FY 2016-17 were estimated to be at approximately \$34,000,000.00 and (a) in recognition of additional costs incurred by the City in connection with the Convention Center Project, including expenses resulting from Hurricane Irma and other unforeseen circumstances, authorized the allocation of excess Trust Fund revenues in the amount of \$6,914,221.00 to the Convention Center Project, and (b) in recognition of the joinder by the City, the County and the City of Miami to the Rockefeller Foundation's 100 Resilient Cities network as Greater Miami and the Beaches and commitment to developing a resilience strategy that, among other things, aggressively combats the risks of rising sea levels, coastal erosion, and hurricanes, provides protection from storm surges associated with

hurricanes and other storm events, maintains and protects our coastal beaches, which provide direct benefits and protection to the people, property and infrastructure developed on the barrier islands and which are a major feature of the Greater Miami and the Beaches tourism industry attracting visitors from all over the world to our community, authorized the distribution of excess Trust Fund Revenues to the County and the City beginning FY 2017-18 and continuing until FY 2022-23, with the County and City each setting aside \$1,500,000.00 per year from the foregoing distribution of excess Trust Fund revenues to fund beach renourishment efforts, which can be used to leverage State or Federal funding for beach renourishment purposes, and (c) in recognition of the continuing need to refurbish the Lincoln Road pedestrian mall from Collins Avenue to West Avenue and adjacent corridors, authorized the distribution of an amount up to \$20,000,000.00 to fund the Lincoln Road Project previously authorized as part of the Third Amendment, for a total project amount of up to \$40,000,000.00 for the Lincoln Road Project; and

WHEREAS, after distribution of Tax Increment Revenues in the order, priority, and amounts required by this Interlocal Agreement, the available revenues remaining on deposit in the Trust Fund, as of the Agency's year-end for FY 2020-21, are estimated to be approximately \$31,900,000.00; and

WHEREAS, the City was engaged in complex litigation relating to the work performed on the Convention Center Project and the City Commission, through Resolution No. 2021-31870, approved a final settlement agreement dated as of September 30, 2021 by and among the City, Clark Construction Group, LLC (the "Contractor") and Hill International Inc. (the "Final Settlement Agreement") pursuant to which the parties settled all claims among them in connection with the Convention Center Project; and

WHEREAS, pursuant to the Final Settlement Agreement, the City is responsible for generating \$33,500,000.00 payable for the remaining project costs in connection with the Convention Center Project, including payments to the Contractor, of which amount the City has already appropriated approximately \$6,400,000.00, which was part of the Convention Center Project budget contingency, and \$27,100,000.00 remains unfunded; and

WHEREAS, completion of the Conventional Center Project is essential to the success of the Redevelopment Area and implementation of the Plan, and accordingly, the City is requesting to access \$27,100,000.00 of the approximately \$31,900,000.00 in excess Trust Fund revenues for purposes of funding the balance of, and reimbursing the City for, the remaining project costs in connection with the Convention Center Project, including payments to the Contractor pursuant to the Final Settlement Agreement; and

WHEREAS, the County and City recognize the importance of the Convention Center Project to the economic vitality of both the County and the City and the benefits to both the County and the City of resolving all claims pursuant to the Final Settlement Agreement and achieving completion of the Convention Center Project; and

WHEREAS, the Agency and the City have adopted Resolution Nos. 666-2022 and 2022-32014, respectively, which are in substantially the forms attached to and incorporated by reference in this resolution as composite Exhibit A (excluding attachments thereto), and which approve the Fifth Amendment to the CRA Interlocal Agreement (the "Fifth Amendment"), which Fifth Amendment is in substantially the form attached to and incorporated by reference in this resolution as Exhibit B; and

WHEREAS, the Agency and the City request that this Board approve the Fifth Amendment,

NOW, THEREFORE, BE IT RESOLVED BY THE BOARD OF COUNTY COMMISSIONERS OF MIAMI-DADE COUNTY, FLORIDA, that:

Section 1. The foregoing recitations are incorporated in the body of this resolution by reference and are hereby approved by this Board.

Section 2. This Board approves the Fifth Amendment in substantially the form attached to and incorporated by reference in this resolution as Exhibit B. The County Mayor or the County Mayor's designee is authorized to execute the Fifth Amendment on behalf of Miami-Dade County and to exercise all provisions contained therein.

The foregoing resolution was offered by Commissioner _____, who moved its adoption. The motion was seconded by Commissioner _____ and upon being put to a vote, the vote was as follows:

Jose "Pepe" Diaz, Chairman	
Oliver G. Gilbert, III, Vice-Chairman	
Sen. René García	Keon Hardemon
Sally A. Heyman	Danielle Cohen Higgins
Eileen Higgins	Joe A. Martinez
Kionne L. McGhee	Jean Monestime
Raquel A. Regalado	Rebeca Sosa
Sen. Javier D. Souto	

The Chairperson thereupon declared this resolution duly passed and adopted this 15th day of March, 2022. This resolution shall become effective upon the earlier of (1) 10 days after the date of its adoption unless vetoed by the County Mayor, and if vetoed, shall become effective only upon an override by this Board, or (2) approval by the County Mayor of this resolution and the filing of this approval with the Clerk of the Board.

MIAMI-DADE COUNTY, FLORIDA
BY ITS BOARD OF
COUNTY COMMISSIONERS

HARVEY RUVIN, CLERK

By: _____
Deputy Clerk

Approved by County Attorney as
to form and legal sufficiency.

dsh

David Stephen Hope

RESOLUTION NO. 666-2022

A RESOLUTION OF THE CHAIRPERSON AND MEMBERS OF THE MIAMI BEACH REDEVELOPMENT AGENCY, APPROVING, IN SUBSTANTIAL FORM, A FIFTH AMENDMENT, BY AND AMONG THE CITY OF MIAMI BEACH (CITY), MIAMI-DADE COUNTY (COUNTY), AND THE MIAMI BEACH REDEVELOPMENT AGENCY (RDA) TO THE NOVEMBER 16, 1993 INTERLOCAL COOPERATION AGREEMENT, AS AMENDED (THE "INTERLOCAL AGREEMENT"), RELATED TO THE CITY CENTER / HISTORIC CONVENTION CENTER VILLAGE REDEVELOPMENT AND REVITALIZATION AREA (CITY CENTER RDA); WITH SAID FIFTH AMENDMENT ATTACHED AS EXHIBIT "A" TO THE MEMORANDUM ACCOMPANYING THIS RESOLUTION; AND FURTHER AUTHORIZING THE CHAIR AND SECRETARY TO EXECUTE THE FINAL FIFTH AMENDMENT, IN THE FORM APPROVED BY THE RDA GENERAL COUNSEL.

WHEREAS, the Miami-Dade County Board of County Commissioners (the "Board") adopted Resolution No. R-317-93 on March 30, 1993, approving, among other things, the City Center/Historic Convention Village Redevelopment and Revitalization Plan (the "Plan") and delegated certain powers conferred on the Board by Part III, Chapter 163, Florida Statutes (the "Act"), to implement the Plan to the Mayor and City Commission of the City of Miami Beach (the "City Commission"), all for the project area commonly called "City Center/Historic Convention Village Redevelopment and Revitalization Area" (such Area previously referred to in the Interlocal Agreement described below, as the "Project" and herein referred to as the "Redevelopment Area"); and

WHEREAS, the City Commission enacted Ordinance 93-2836 on February 24, 1993 and the Board also enacted Ordinance No. 93-28 on April 27, 1993, which among other things, established a trust fund ("Fund" or "Trust Fund") to fund improvements in the Redevelopment Area; and

WHEREAS, the County and the City also approved and entered into the Interlocal Cooperation Agreement, executed on November 16, 1993, as amended by the First Amendment (defined below), by the Second Amendment (defined below), by the Third Amendment (defined below), and by the Fourth Amendment (defined below) (collectively, the "Interlocal Agreement"), by which the County delegated to the City certain redevelopment powers granted by the Act, including but not limited to the creation of the Redevelopment Area and implementation of the Plan; and

WHEREAS, the Board, through Resolution No. R-889-03, and the City Commission, through Resolution No. 2003-2537, approved an amendment to the Plan to incorporate the development and implementation of community policing initiatives; and

WHEREAS, the Board, through Resolution No. R-889-03, and the City Commission, through Resolution No. 2003-25241, also approved an amendment to the Interlocal Agreement ("First Amendment") to delegate to the City the power to implement the community policing initiatives; and

WHEREAS, the Board, through Resolution No. R-958-05, the City Commission, through Resolution No. 2004-25560, and the Agency, through Resolution No. 470-2004, also approved a second amendment to the Interlocal Agreement ("Second Amendment") whereby:

- (i) the County, City, and Agency agreed that the Agency would remit one and one-half percent (1.5%) of the tax increment revenue paid to the Agency for said fiscal year to the County to defray administrative costs for oversight and processing Agency related items, after satisfaction each fiscal year of debt service and all other obligations related to the bonds or future indebtedness issued by the Agency and approved by the County, and
- (ii) the County approved the Agency's issuance of refunding bonds in an amount not to exceed a principal amount of \$101,090,000.00 to refinance all or a portion of the outstanding principal amount of bonds issued with respect to the Redevelopment Area; and

WHEREAS, the Board, through Resolution No. R-1110-14, the City Commission, through Resolution No. 2014-28835, and the Agency, through Resolution No. 607-2014, also approved a third amendment to the Interlocal Agreement ("Third Amendment"), which, among other terms, extended the life of the Agency to March 31, 2044, authorized the issuance of tax increment revenue bonds ("RDA Bonds") to support the Convention Center Renovation and Expansion Project (the "Convention Center Project"), and further provided for related payment terms, with the intent that all available excess Trust Fund revenues remaining on deposit in the Trust Fund be used for the prepayment or redemption of debt prior to maturity of the RDA Bonds, with such prepayment or redemption of debt commencing in FY 2023-24; and

WHEREAS, the Board, through Resolution No. R-644-18, the City Commission, through Resolution No. 2018-30288, and the Agency, through Resolution No. 629-2018, also approved a fourth amendment to the Interlocal Agreement ("Fourth Amendment"), which, among other terms, recognized that the available revenues remaining on deposit in the Trust Fund, as of the Agency's year-end for FY 2016-17, were estimated to be at approximately \$34,000,000 and:

- (i) in recognition of additional costs incurred by the City in connection with the Convention Center Project, including expenses resulting from Hurricane Irma and other unforeseen circumstances, authorized the allocation of excess Trust Fund revenues in the amount of \$6,914,221.00 to the Convention Center Project, and
- (ii) in recognition of the joinder by the City, the County, and the City of Miami to the Rockefeller Foundation's 100 Resilient Cities network as Greater Miami and the Beaches and commitment to developing a resilience strategy that, among other things, aggressively combats the risks of rising sea levels, coastal erosion, and hurricanes, provides protection from storm surges associated with hurricanes and other storm events, maintains and protects our coastal beaches, which provide direct benefits and protection to the people, property, and infrastructure developed on the barrier islands and which are a major feature of the Greater Miami and the Beaches tourism industry, attracting visitors from all over the world to our community, authorized the distribution of excess Trust Fund revenues to the County and the City beginning FY 2017-18 and continuing until FY 2022-23, with the County and City each setting aside \$1.5 million per year from the foregoing distribution of excess Trust Fund revenues to fund beach renourishment efforts, which can be used to leverage State or Federal funding for beach renourishment purposes, and
- (iii) in recognition of the continuing need to refurbish the Lincoln Road pedestrian mall from Collins Avenue to West Avenue and adjacent corridors, authorized the

distribution of an amount up to \$20,000,000 to fund the Lincoln Road Project previously authorized as part of the Third Amendment, for a total project amount of up to \$40,000,000 for the Lincoln Road Project; and

WHEREAS, after distribution of Tax Increment revenues in the order, priority, and amounts required by this Interlocal Agreement, the available revenues remaining on deposit in the Trust Fund, as of the Agency's year-end for FY 2020-21, are projected at approximately \$31,900,000.00; and

WHEREAS, the County desires to expand the use of the excess Trust Fund revenues set aside by the County for the purpose of funding beach renourishment to be used for any beaches located within Miami-Dade County, as determined in the County's sole discretion; and

WHEREAS, the County and the City recognize the importance to both the County and the City of renourishing all beaches throughout Miami-Dade County; and

WHEREAS, the Agency has served as a prominent funding mechanism for the transformative renovation and expansion of the Miami Beach Convention Center ("Convention Center Project"), which is the only convention center located in Miami-Dade County and is a significant economic asset for the City and the entire County, hosting major recurring events such as Art Basel and periodic sports tourism events like the NFL Superbowl Experience; and

WHEREAS, the City was engaged in complex litigation relating to the work performed on the Convention Center Project and the City Commission, through Resolution No. 2021-31870, approved a final settlement agreement dated as of September 30, 2021 by and among the City, Clark Construction Group, LLC ("Contractor"), and Hill International Inc. (the "Final Settlement Agreement") pursuant to which the parties settled all claims among them in connection with the Convention Center Project; and

WHEREAS, pursuant to the Final Settlement Agreement, the City is responsible for generating \$33,500,000.00 payable for the remaining project costs in connection with the Convention Center Project, including payments to the Contractor, of which amount the City has already appropriated approximately \$6,400,000.00, which was part of the Convention Center Project budget contingency, and \$27,100,000.00 remains unfunded; and

WHEREAS, the Convention Center Project budget had included a contingency of \$35,000,000.00, which represents only approximately six percent (6%) of the total Convention Center Project budget; and

WHEREAS, the remaining unfunded Convention Center Project costs in the amount of \$27,100,000.00 represents approximately four percent (4%) of the total Convention Center Project budget, and when combined with the original contingency amount, effectively brings the total Convention Center Project contingency to approximately ten percent (10%) of the budget, which is well within industry standards; and

WHEREAS, completion of the Convention Center Project is essential to the success of the Redevelopment Area and implementation of the Plan, and accordingly, the City is requesting to access \$27,100,000.00 of the approximately \$31,900,000.00 in excess Trust Fund revenues for purposes of funding the balance of, and reimbursing the City for, the remaining project costs

in connection with the Convention Center Project, including payments to the Contractor pursuant to the Final Settlement Agreement; and

WHEREAS, given the importance of the Convention Center Project to their economic vitality, both the County and the City recognize the mutual benefits of resolving all claims pursuant to the Final Settlement Agreement and achieving completion of the Convention Center Project;

WHEREAS, to effectuate the foregoing purposes, the County, City, and Agency have negotiated a proposed amendment to the Interlocal Agreement ("Fifth Amendment"), attached in substantial form as Exhibit "A" to the Memorandum accompanying this Resolution, with said Fifth Amendment providing in material part:

- Until FY 2022-23, the County shall set aside \$1.5 million per year of the excess Trust Fund revenue payments received from the Agency for the purpose of funding beach renourishment for any beaches within Miami-Dade County, as opposed to only beaches within or adjacent to the City of Miami Beach, as determined in the County's sole discretion.
- of the approximately \$31,900,000.00 in excess Trust Fund revenues remaining on deposit in the Trust Fund as of the Agency's year-end for FY 2020-21, the Agency shall distribute \$27,100,000.00 to the City, for the limited purpose of funding, and reimbursing the City for, the remaining project costs in connection with the Convention Center Project, including payments to the Contractor pursuant to the Final Settlement Agreement.

WHEREAS, upon approval by the Agency and the City Commission, respectively, the Fifth Amendment will be transmitted to the County, for consideration and approval by the Board.

NOW, THEREFORE, BE IT DULY RESOLVED BY THE CHAIRPERSON AND MEMBERS OF THE MIAMI BEACH REDEVELOPMENT AGENCY, that the Chairperson and Members of the Miami Beach Redevelopment Agency hereby approve, in substantial form, a Fifth Amendment, by and among the City of Miami Beach (City), Miami-Dade County (County), and the Miami Beach Redevelopment Agency (RDA) to the November 16, 1993 Interlocal Cooperation Agreement, as amended (the "Interlocal Agreement"), related to the City Center / Historic Convention Center Village Redevelopment and Revitalization Area (City Center RDA); with said Fifth Amendment attached as Exhibit "A" to the City Commission Memorandum accompanying this Resolution; and further authorizing the Mayor and City Clerk to execute the final Fifth Amendment, in the form approved by the City Attorney.

PASSED and ADOPTED THIS 20 day of January 2022.

ATTEST:



 RAFAEL E. GRANADO, SECRETARY



 DAN GELBER, CHAIRPERSON



**APPROVED AS TO
FORM & LANGUAGE
& FOR EXECUTION**

 12-28-21

 Redevelopment Agency Date
 General Counsel PAZ

RESOLUTION NO. 2022-32014

A RESOLUTION OF THE MAYOR AND CITY COMMISSION OF THE CITY OF MIAMI BEACH, FLORIDA, APPROVING, IN SUBSTANTIAL FORM, A FIFTH AMENDMENT, BY AND AMONG THE CITY OF MIAMI BEACH (CITY), MIAMI-DADE COUNTY (COUNTY), AND THE MIAMI BEACH REDEVELOPMENT AGENCY (RDA) TO THE NOVEMBER 16, 1993 INTERLOCAL COOPERATION AGREEMENT, AS AMENDED (THE "INTERLOCAL AGREEMENT"), RELATED TO THE CITY CENTER / HISTORIC CONVENTION CENTER VILLAGE REDEVELOPMENT AND REVITALIZATION AREA (CITY CENTER RDA); WITH SAID FIFTH AMENDMENT ATTACHED AS EXHIBIT "A" TO THE CITY COMMISSION MEMORANDUM ACCOMPANYING THIS RESOLUTION; AND FURTHER AUTHORIZING THE MAYOR AND CITY CLERK TO EXECUTE THE FINAL FIFTH AMENDMENT, IN THE FORM APPROVED BY THE CITY ATTORNEY.

WHEREAS, the Miami-Dade County Board of County Commissioners (the "Board") adopted Resolution No. R-317-93 on March 30, 1993, approving, among other things, the City Center/Historic Convention Village Redevelopment and Revitalization Plan (the "Plan") and delegated certain powers conferred on the Board by Part III, Chapter 163, Florida Statutes (the "Act"), to implement the Plan to the Mayor and City Commission of the City of Miami Beach (the "City Commission"), all for the project area commonly called "City Center/Historic Convention Village Redevelopment and Revitalization Area" (such Area previously referred to in the Interlocal Agreement described below, as the "Project" and herein referred to as the "Redevelopment Area"); and

WHEREAS, the City Commission enacted Ordinance 93-2836 on February 24, 1993 and the Board also enacted Ordinance No. 93-28 on April 27, 1993, which among other things, established a trust fund ("Fund" or "Trust Fund") to fund improvements in the Redevelopment Area; and

WHEREAS, the County and the City also approved and entered into the Interlocal Cooperation Agreement, executed on November 16, 1993, as amended by the First Amendment (defined below), by the Second Amendment (defined below), by the Third Amendment (defined below), and by the Fourth Amendment (defined below) (collectively, the "Interlocal Agreement"), by which the County delegated to the City certain redevelopment powers granted by the Act, including but not limited to the creation of the Redevelopment Area and implementation of the Plan; and

WHEREAS, the Board, through Resolution No. R-889-03, and the City Commission, through Resolution No. 2003-2537, approved an amendment to the Plan to incorporate the development and implementation of community policing initiatives; and

WHEREAS, the Board, through Resolution No. R-889-03, and the City Commission, through Resolution No. 2003-25241, also approved an amendment to the Interlocal Agreement ("First Amendment") to delegate to the City the power to implement the community policing initiatives; and

WHEREAS, the Board, through Resolution No. R-958-05, the City Commission, through Resolution No. 2004-25560, and the Agency, through Resolution No. 470-2004, also approved a second amendment to the Interlocal Agreement ("Second Amendment") whereby:

- (i) the County, City, and Agency agreed that the Agency would remit one and one-half percent (1.5%) of the tax increment revenue paid to the Agency for said fiscal year to the County to defray administrative costs for oversight and processing Agency related items, after satisfaction each fiscal year of debt service and all other obligations related to the bonds or future indebtedness issued by the Agency and approved by the County, and
- (ii) the County approved the Agency's issuance of refunding bonds in an amount not to exceed a principal amount of \$101,090,000.00 to refinance all or a portion of the outstanding principal amount of bonds issued with respect to the Redevelopment Area; and

WHEREAS, the Board, through Resolution No. R-1110-14, the City Commission, through Resolution No. 2014-28835, and the Agency, through Resolution No. 607-2014, also approved a third amendment to the Interlocal Agreement ("Third Amendment"), which, among other terms, extended the life of the Agency to March 31, 2044, authorized the issuance of tax increment revenue bonds ("RDA Bonds") to support the Convention Center Renovation and Expansion Project (the "Convention Center Project"), and further provided for related payment terms, with the intent that all available excess Trust Fund revenues remaining on deposit in the Trust Fund be used for the prepayment or redemption of debt prior to maturity of the RDA Bonds, with such prepayment or redemption of debt commencing in FY 2023-24; and

WHEREAS, the Board, through Resolution No. R-644-18, the City Commission, through Resolution No. 2018-30288, and the Agency, through Resolution No. 629-2018, also approved a fourth amendment to the Interlocal Agreement ("Fourth Amendment"), which, among other terms, recognized that the available revenues remaining on deposit in the Trust Fund, as of the Agency's year-end for FY 2016-17, were estimated to be at approximately \$34,000,000 and:

- (i) in recognition of additional costs incurred by the City in connection with the Convention Center Project, including expenses resulting from Hurricane Irma and other unforeseen circumstances, authorized the allocation of excess Trust Fund revenues in the amount of \$6,914,221.00 to the Convention Center Project, and
- (ii) in recognition of the joinder by the City, the County, and the City of Miami to the Rockefeller Foundation's 100 Resilient Cities network as Greater Miami and the Beaches and commitment to developing a resilience strategy that, among other things, aggressively combats the risks of rising sea levels, coastal erosion, and hurricanes, provides protection from storm surges associated with hurricanes and other storm events, maintains and protects our coastal beaches, which provide direct benefits and protection to the people, property, and infrastructure developed on the barrier islands and which are a major feature of the Greater Miami and the Beaches tourism industry, attracting visitors from all over the world to our community, authorized the distribution of excess Trust Fund revenues to the County and the City beginning FY 2017-18 and continuing until FY 2022-23, with the County and City each setting aside \$1.5 million per year from the foregoing distribution of excess Trust Fund revenues to fund beach renourishment efforts, which can be used to leverage State or Federal funding for beach renourishment purposes, and
- (iii) in recognition of the continuing need to refurbish the Lincoln Road pedestrian mall from Collins Avenue to West Avenue and adjacent corridors, authorized the

distribution of an amount up to \$20,000,000 to fund the Lincoln Road Project previously authorized as part of the Third Amendment, for a total project amount of up to \$40,000,000 for the Lincoln Road Project; and

WHEREAS, after distribution of Tax Increment revenues in the order, priority, and amounts required by this Interlocal Agreement, the available revenues remaining on deposit in the Trust Fund, as of the Agency's year-end for FY 2020-21, are projected at approximately \$31,900,000.00; and

WHEREAS, the County desires to expand the use of the excess Trust Fund revenues set aside by the County for the purpose of funding beach renourishment to be used for any beaches located within Miami-Dade County, as determined in the County's sole discretion; and

WHEREAS, the County and the City recognize the importance to both the County and the City of renourishing all beaches throughout Miami-Dade County; and

WHEREAS, the Agency has served as a prominent funding mechanism for the transformative renovation and expansion of the Miami Beach Convention Center ("Convention Center Project"), which is the largest convention center in Miami-Dade County and a significant economic asset for the City and the entire County, hosting major recurring events such as Art Basel and periodic sports tourism events like the NFL Superbowl Experience; and

WHEREAS, the City was engaged in complex litigation relating to the work performed on the Convention Center Project and the City Commission, through Resolution No. 2021-31870, approved a final settlement agreement dated as of September 30, 2021 by and among the City, Clark Construction Group, LLC ("Contractor"), and Hill International Inc. (the "Final Settlement Agreement") pursuant to which the parties settled all claims among them in connection with the Convention Center Project; and

WHEREAS, pursuant to the Final Settlement Agreement, the City is responsible for generating \$33,500,000.00 payable for the remaining project costs in connection with the Convention Center Project, including payments to the Contractor, of which amount the City has already appropriated approximately \$6,400,000.00, which was part of the Convention Center Project budget contingency, and \$27,100,000.00 remains unfunded; and

WHEREAS, the Convention Center Project budget had included a contingency of \$35,000,000.00, which represents only approximately six percent (6%) of the total Convention Center Project budget; and

WHEREAS, the remaining unfunded Convention Center Project costs in the amount of \$27,100,000.00 represents approximately four percent (4%) of the total Convention Center Project budget, and when combined with the original contingency amount, effectively brings the total Convention Center Project contingency to approximately ten percent (10%) of the budget, which is well within industry standards; and

WHEREAS, completion of the Convention Center Project is essential to the success of the Redevelopment Area and implementation of the Plan, and accordingly, the City is requesting to access \$27,100,000.00 of the approximately \$31,900,000.00 in excess Trust Fund revenues for purposes of funding the balance of, and reimbursing the City for, the remaining project costs

in connection with the Convention Center Project, including payments to the Contractor pursuant to the Final Settlement Agreement; and

WHEREAS, given the importance of the Convention Center Project to their economic vitality, both the County and the City recognize the mutual benefits of resolving all claims pursuant to the Final Settlement Agreement and achieving completion of the Convention Center Project;

WHEREAS, to effectuate the foregoing purposes, the County, City, and Agency have negotiated a proposed amendment to the Interlocal Agreement ("Fifth Amendment"), attached in substantial form as Exhibit "A" to the Memorandum accompanying this Resolution, with said Fifth Amendment providing in material part:

- Until FY 2022-23, the County shall set aside \$1.5 million per year of the excess Trust Fund revenue payments received from the Agency for the purpose of funding beach renourishment for any beaches within Miami-Dade County, as opposed to only beaches within or adjacent to the City of Miami Beach, as determined in the County's sole discretion.
- of the approximately \$31,900,000.00 in excess Trust Fund revenues remaining on deposit in the Trust Fund as of the Agency's year-end for FY 2020-21, the Agency shall distribute \$27,100,000.00 to the City, for the limited purpose of funding, and reimbursing the City for, the remaining project costs in connection with the Convention Center Project, including payments to the Contractor pursuant to the Final Settlement Agreement.

WHEREAS, upon approval by the Agency and the City Commission, respectively, the Fifth Amendment will be transmitted to the County, for consideration and approval by the Board.

NOW, THEREFORE, BE IT DULY RESOLVED BY THE MAYOR AND CITY COMMISSION OF THE CITY OF MIAMI BEACH, FLORIDA, that the Mayor and City Commission hereby approve, in substantial form, a Fifth Amendment, by and among the City of Miami Beach (City), Miami-Dade County (County), and the Miami Beach Redevelopment Agency (RDA) to the November 16, 1993 Interlocal Cooperation Agreement, as amended (the "Interlocal Agreement"), related to the City Center / Historic Convention Center Village Redevelopment and Revitalization Area (City Center RDA); with said Fifth Amendment attached as Exhibit "A" to the City Commission Memorandum accompanying this Resolution; and further authorizing the Mayor and City Clerk to execute the final Fifth Amendment, in the form approved by the City Attorney.

PASSED and ADOPTED THIS 20 day of January 2022.

ATTEST:

1/24/22
 RAFAEL E. GRAN, CITY CLERK

 DAN GELBER, MAYOR

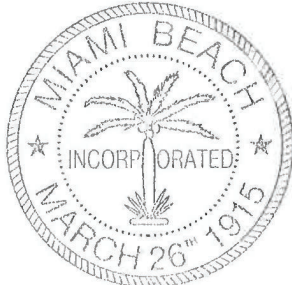

APPROVED AS TO
FORM & LANGUAGE
& FOR EXECUTION

 City Attorney PAZ 12-28-21
 Date

**FIFTH AMENDMENT TO
THE INTERLOCAL COOPERATION AGREEMENT**

This Fifth Amendment to the Interlocal Cooperation Agreement (the “Fifth Amendment”), made this _____ day of _____, 2022 (the “Effective Date”), by and among Miami-Dade County, a political subdivision of the State of Florida (the “County”), the City of Miami Beach, a municipal corporation under the laws of the State of Florida (the “City”), and the Miami Beach Redevelopment Agency, a public agency and body corporate created pursuant to Section 163.356, Florida Statutes (the “Agency”).

WHEREAS, the Miami-Dade County Board of County Commissioners (the “Board”) adopted Resolution No. R-317-93 on March 30, 1993, approving, among other things, the City Center/Historic Convention Village Redevelopment and Revitalization Plan (the “Plan”), and delegated certain powers conferred on the Board by Part III, Chapter 163, Florida Statutes (the “Act”), to implement the Plan to the Mayor and City Commission of the City of Miami Beach (the “City Commission”), all for the project area commonly called “City Center/Historic Convention Village Redevelopment and Revitalization Area” (the “Area”), and such Area previously referred to in the Interlocal Agreement described below as the “Project”, and herein referred to as the “Redevelopment Area”; and

WHEREAS, the Board also enacted Ordinance No. 93-28 on April 27, 1993, which among other things, established a trust fund (the “Fund” or “Trust Fund”) to fund improvements in the Redevelopment Area; and

WHEREAS, the County and the City also approved and entered into the Interlocal Cooperation Agreement, executed on November 16, 1993 (the “Interlocal Agreement), as amended by the First Amendment (defined below), by the Second Amendment (defined below),

by the Third Amendment (defined below), and by the Fourth Amendment (defined below), by which the County delegated to the City certain redevelopment powers granted by the Act, including but not limited to the creation of the Redevelopment Area and implementation of the Plan; and

WHEREAS, the County and the City adopted Resolution No. R-889-03 and Resolution No. 2003-2537, respectively, approving an amendment to the Plan to incorporate the development and implementation of community policing initiatives; and

WHEREAS, the Board, through Resolution No. R-889-03, and the City Commission, through Resolution No. 2003-25241, also approved an amendment to the Interlocal Agreement (the “First Amendment”) to delegate to the City the power to implement the community policing initiatives; and

WHEREAS, the Board, through Resolution No. R-958-05, and the City Commission, through Resolution No. 2004-25560, also approved a second amendment to the Interlocal Agreement (“Second Amendment”) whereby (i) the County, City, and Agency agreed that the Agency would remit one and one-half percent (1.5%) of the Tax Increment Revenue paid to the Agency for said fiscal year to the County to defray administrative costs for oversight and processing Agency related items, after debt service and all other obligations related to the bonds or future indebtedness issued by the Agency and approved by the County was satisfied for the fiscal year, and (ii) the County approved the Agency’s issuance of refunding bonds in an amount not to exceed a principal amount of \$101,090,000.00 to refinance all or a portion of the outstanding principal amount of bonds issued with respect to the Redevelopment Area; and

WHEREAS, the Board, through Resolution No. R-1110-14, and the City Commission, through Resolution No. 2014-28835, also approved a third amendment to the Interlocal Agreement

(the “Third Amendment”), which, among other terms, extended the life of the Agency to March 31, 2044, authorized the issuance of tax increment revenue bonds (the “RDA Bonds”) to support the Convention Center Renovation and Expansion Project (the “Convention Center Project”), and further provided for related payment terms, with the intent that all available excess Trust Fund revenues remaining on deposit in the Trust Fund be used for the prepayment or redemption of debt prior to maturity of the RDA Bonds, with such prepayment or redemption of debt commencing in FY 2023-2024; and

WHEREAS, the Board, through Resolution No. R-644-18, the City Commission, through Resolution No. 2018-30288, and the Agency, through Resolution No. 629-2018, also approved a fourth amendment to the Interlocal Agreement (the “Fourth Amendment”), which, among other terms, recognized that the available revenues remaining on deposit in the Trust Fund, as of the Agency’s year-end for FY 2016-17 were estimated to be at approximately \$34,000,000 and (a) in recognition of additional costs incurred by the City in connection with the Convention Center Project, including expenses resulting from Hurricane Irma and other unforeseen circumstances, authorized the allocation of excess Trust Fund revenues in the amount of \$6,914,221.00 to the Convention Center Project, and (b) in recognition of the joinder by the City, the County and the City of Miami to the Rockefeller Foundation’s 100 Resilient Cities network as Greater Miami and the Beaches and commitment to developing a resilience strategy that, among other things, aggressively combats the risks of rising sea levels, coastal erosion, and hurricanes, provides protection from storm surges associated with hurricanes and other storm events, maintains and protects our coastal beaches, which provide direct benefits and protection to the people, property and infrastructure developed on the barrier islands and which are a major feature of the Greater Miami and the Beaches tourism industry attracting visitors from all over the world to our

community, authorized the distribution of excess Trust Fund Revenues to the County and the City beginning FY 2017-18 and continuing until FY 2022-23, with the County and City each setting aside \$1.5 million per year from the foregoing distribution of excess Trust Fund revenues to fund beach renourishment efforts, which can be used to leverage State or Federal funding for beach renourishment purposes, and (c) in recognition of the continuing need to refurbish the Lincoln Road pedestrian mall from Collins Avenue to West Avenue and adjacent corridors, authorized the distribution of an amount up to \$20,000,000 to fund the Lincoln Road Project previously authorized as part of the Third Amendment, for a total project amount of up to \$40,000,000 for the Lincoln Road Project; and

WHEREAS, after distribution of Tax Increment Revenues in the order, priority, and amounts required by this Interlocal Agreement, the available revenues remaining on deposit in the Trust Fund, as of the Agency's year-end for FY 2020-21, are projected at approximately \$31,900,000.00 and

WHEREAS, the County is requesting to expand the use of the excess Trust Fund revenues set aside by the County for the purpose of funding beach renourishment to be used for any beaches within Miami-Dade County in the County's sole discretion; and

WHEREAS, the County and the City recognize the importance to both the County and the City of renourishing all beaches within Miami-Dade County; and

WHEREAS, the Agency has served as a prominent funding mechanism for the transformative renovation of the Convention Center Project, which is the only convention center in Miami-Dade County and is an important economic asset of the County and the City, hosting major recurring events such as Art Basel and periodic sports tourism events like the NFL Superbowl Experience; and

WHEREAS, the City was engaged in complex litigation relating to the work performed on the Convention Center Project and the City Commission, through Resolution No. 2021-31870, approved a final settlement agreement dated as of September 30, 2021 by and among the City, Clark Construction Group, LLC (the “Contractor”) and Hill International Inc. (the “Final Settlement Agreement”) pursuant to which the parties settled all claims among them in connection with the Convention Center Project; and

WHEREAS, pursuant to the Final Settlement Agreement, the City is responsible for generating \$33,500,000.00 payable for the remaining project costs in connection with the Convention Center Project, including payments to the Contractor, of which amount the City has already appropriated approximately \$6,400,000.00, which was part of the Convention Center Project budget contingency, and \$27,100,000.00 remains unfunded; and

WHEREAS, the Convention Center Project budget had included a contingency of \$35,000,000.00, which represents only approximately six percent (6%) of the total Convention Center Project budget; and

WHEREAS, the remaining unfunded Convention Center Project costs are \$27,100,000.00, which represents approximately four percent (4%) of the total Convention Center Project budget, and when combined with the original contingency amount, effectively brings the total Convention Center Project contingency to approximately ten percent (10%) of the budget, which is well within industry standards; and

WHEREAS, completion of the Conventional Center Project is essential to the success of the Redevelopment Area and implementation of the Plan, and accordingly, the City is requesting to access \$27,100,000.00 of the projected \$31,900,000.00 in excess Trust Fund revenues for purposes of funding the balance of, and reimbursing the City for, the remaining project costs in

connection with the Convention Center Project, including payments to the Contractor pursuant to the Final Settlement Agreement; and

WHEREAS, the County and City recognize the importance of the Convention Center Project to the economic vitality of both the County and the City and the benefits to both the County and the City of resolving all claims pursuant to the Final Settlement Agreement and achieving completion of the Convention Center Project.

NOW, THEREFORE, for and in consideration of the premises and the mutual covenants recorded herein, the County, the City and the Agency agree as follows:

A. The recitations set forth above are true and correct and adopted as part of this Fifth Amendment.

B. Paragraph XII, "Distribution of Trust Fund Revenues," sub-paragraphs "E and H" of the Interlocal Agreement, are hereby amended to read as follows:

E. The Agency agrees to:

1. Beginning FY 2017-18, and until the earlier of March 31, 2044, or the termination or expiration of the taxing authorities' obligation to appropriate the Tax Increment Revenues to the Fund, grant to the County an amount equal to the County's proportionate share of the total payments expended by the Agency in the prior fiscal year for Administration, Community Policing, and Capital Project Maintenance (defined below). Such grant shall be paid to the County by March 31 of each year and shall be based on the previous year's expenses for Administration, Community Policing, and Capital Project Maintenance. The amount granted annually shall be calculated as follows:

The County's share of total Tax Increment Revenues deposited into the Trust Fund for that particular year divided by the total Tax Increment Revenues collected from all taxing authorities and deposited in the Trust Fund for that particular year, multiplied by the amount of expenses paid by the Agency in the previous fiscal year for Administration, Community Policing and Capital Project Maintenance.

Beginning FY 2017-18, and until FY 2022-23, the County shall set aside \$1.5 million per year of the payments received from the Agency for the purpose of funding beach renourishment for any¹ beaches within ~~or adjacent to the City of Miami Beach~~ Miami-Dade County in the County's sole discretion. This funding can be used to leverage State or Federal funding for beach renourishment purposes. Such funding shall be set aside in a separate account established by the County to be used for the purposes described herein.

2. Beginning FY 2017-18, until FY 2022-23, grant to the City an amount equal to the City's proportionate share of the total payments expended by the Agency in the prior fiscal year for Administration, Community Policing, and Capital Project Maintenance (defined below). Such grant shall be paid to the City by March 31 of each year and shall be based on the previous year's expenses for Administration, Community Policing, and Capital Project Maintenance. The amount granted annually shall be calculated as follows:

The City's share of total Tax Increment Revenues deposited into the Trust Fund for that particular year divided by the total Tax Increment Revenues collected from all taxing authorities and deposited in the Trust Fund for that particular year, multiplied by the amount of expenses paid by the Agency in the previous fiscal year for Administration, Community Policing and Capital Project Maintenance.

Beginning FY 2017-18, and until FY 2022-23, the City shall set aside \$1.5 million per year of the grant received from the Agency for the purpose of funding beach renourishment for beaches within the City of Miami Beach. This funding can be used to leverage State or Federal funding for beach renourishment purposes. Such funding shall be set aside in a separate account established by the City to be used for the purposes described herein.

* * *

- H. Beginning FY 2014-15 and ending on the earlier of March 31, 2023, or the termination or expiration of the taxing authorities' obligation to appropriate Tax Increment Revenue to the Trust Fund, the Agency shall, within ninety (90) days from the conclusion of each fiscal year, deposit any

¹ Words stricken through shall be deleted. Words underscored constitute the amendment proposed. Remaining provisions are now in effect and remain unchanged.

unencumbered amounts on deposit in the Trust Fund and all available revenues remaining after distribution of Tax Increment Revenues in the order, priority and amounts set forth in Sections A through G above, into a fund to be used for the purposes of financing any shortfalls associated with the payment of the expenses as listed in Section F above. Such deposits to such fund shall only be made if it will not negatively affect the exclusion from gross income, for federal income tax purposes, of interest on any tax-exempt Agency Indebtedness. After the above application, the excess funds in the Trust Fund:

1. as of the end of FY 2016-17 shall be distributed as follows: of the approximately \$34 million in revenues remaining on deposit in the Trust Fund as of the Agency's year-end for FY 2016-17, the Agency shall distribute \$6,914,221.00 to the City, for the limited purpose of funding a portion of the construction costs for the Convention Center Project; and

2. after disbursement to the City pursuant to Section H.1 above, the Agency may distribute an amount up to \$20,000,000 to the City, for the limited purpose of funding a portion of the design and construction costs for the Lincoln Road / Collins Avenue to West Avenue Project, for the refurbishment of the Lincoln Road pedestrian mall from Collins Avenue to West Avenue, and adjacent corridors (the "Lincoln Road Project"), which distribution pursuant to this Section H.2, together with the \$20 million previously authorized for the Lincoln Road Project, provides for total funding from excess Tax Increment Revenues of up to \$40,000,000 for the Lincoln Road Project; and

3. as of the end of FY 2020-21 shall be distributed as follows: of the approximately \$31,900,000.00 in excess Trust Fund revenues remaining on deposit in the Trust Fund as of the Agency's year-end for FY 2020-21, the Agency shall distribute \$27,100,000.00 to the City, for the limited purpose of funding, and reimbursing the City for, the remaining project costs in connection with the Convention Center Project, including payments to the Contractor pursuant to the Final Settlement Agreement.

All other remaining revenues in the Trust Fund (including, without limitation, any remaining excess revenues at the end of FY 2020-21) will be used to extinguish Agency Indebtedness early, but not prior to FY 2023-24, to the extent such Agency Indebtedness is subject to prepayment or redemption prior to maturity at such time or, if such Agency Indebtedness is not then subject to prepayment or redemption prior to maturity, to establish an escrow for the prepayment or redemption prior to maturity of such Agency Indebtedness at such time as the Agency Indebtedness is

subject to prepayment or redemption prior to maturity; provided, however, that such escrow shall only be established if it will not negatively affect the exclusion from gross income, for federal tax purposes, of interest on any such tax-exempt Agency Indebtedness. The City and the Agency agree not to issue Capital Appreciation Bonds or similar debt that does not pay interest on a current basis. The City and the Agency also agree that any Agency Indebtedness pledging Tax Increment Revenues issued for the purposes set forth herein shall include a call provision allowing such Agency Indebtedness to be called no later than ten (10) years after initial issuance. If the Agency Indebtedness is not subject to repayment or redemption prior to maturity, and an escrow cannot be established, then the Agency shall distribute annually any revenues remaining on deposit in the Fund after distribution as set forth in Sections A through H of this Paragraph XII, to the taxing authorities in the proportionate manner as it was deposited.

C. All provisions of the Interlocal Agreement, other than the provisions specifically amended herein, remain in full force and effect.

[SIGNATURES APPEAR ON THE FOLLOWING PAGE]

IN WITNESS WHEREOF, the parties have executed this Fifth Amendment as of the date first written above.

CITY OF MIAMI BEACH

MIAMI-DADE COUNTY

By: 
Dan Gelber
Mayor

By: _____
Daniella Levine Cava
Mayor

ATTEST



ATTEST

By:  1/20/2022
City Clerk

By: _____
Deputy Clerk

MIAMI BEACH REDEVELOPMENT AGENCY

Approved for form and legal sufficiency

By: 
Dan Gelber
Chairman

By: _____
Assistant County Attorney

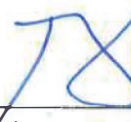
Attest:
By: 
Secretary

Approved for form and legal sufficiency

By:  12/27/21
for Rafael A. Paz
City Attorney